

General Specifications

Model UT350L Limit Controller

GS 05D01D21-01E

Overview

The UT350L is an FM approved limit controller that can be configured either as a high limit or as a low limit controller by a user.

The UT350L features universal input, two alarm outputs, retransmission output, a timer to count the total time the setpoint is exceeded, and a register to retain the maximum temperature reached.

The RS485 communication interface is available optionally.

Features

- The large LED display of measured value whose character is 20mm in height allows the good readability.
- Universal input is provided. The input type can be set and changed easily by software.
- Retransmission function is included in the standard features.

Function Specifications

Limit Control Function

Setpoint : 1
Control type : high limit or low limit
Limit action : latching

When measured value (PV) exceeds the setpoint(SP), both the “Exceeded” lamp and “OUT” lamp turn on.(1)
“Exceeded” lamp turns off when PV goes into normal status, however, “OUT” lamp remains lit.(2)
“OUT” lamp turns off when the confirmation is done with pressing the “RESEST” key by the operator.(3)
The confirmation(RESET) is not allowed while PV exceeds SP.(4)

State of Output Relay

State of output relay is de-energized whenever OUT lamp is lit. When PV has not exceeded SP since power-on, state of output relay is de-energized. (NC terminal : CLOSE, NO terminal : OPEN) and after confirmation is done, the state of output relay is energized. (NC terminal : OPEN, NO terminal : CLOSE)
It is also possible to make the relay energized immediately after power-on by the software setting.
At power-off, the relay is de-energized (NC terminal : CLOSE, NO terminal : OPEN).

Control parameter setting range:

ON/OFF hysteresis band : 0.0 to 100.0 of instrument range width.

Resart mode:

Relay status at power-on can be selected.

UT350L

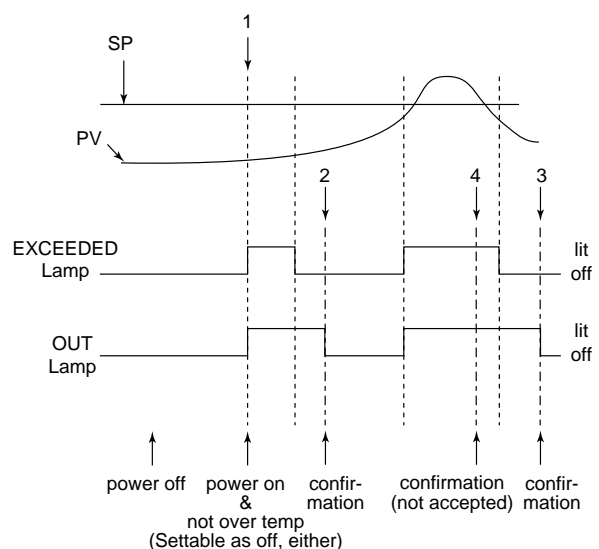
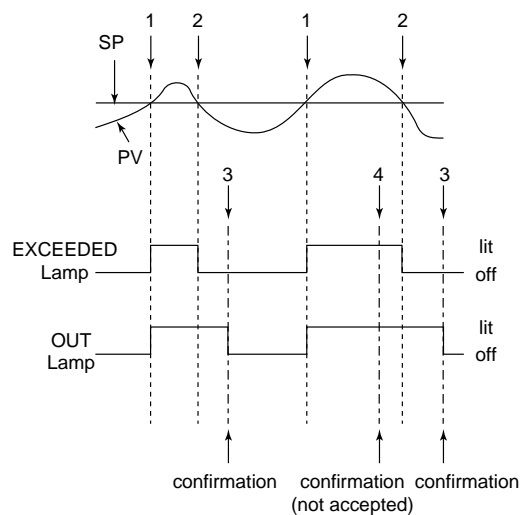

● Signal Computation Function

Measured input computation:

Bias addition (-100.0 to 100.0 % of measured input range width), and first-order lag filter (time constant off or 1 to 120 s)

Contact input function:

Limit output confirmation

● Alarm Function

Types of alarm functions are provided. The alarm status is indicated by the alarm lamp on the front panel. Also, two points among them can be output as relay contact outputs.

Alarm types:

PV high limit, PV low limit, Deviation high limit, Deviation low limit, De-energized on deviation high limit, De-energized on deviation low limit, Deviation high and low limits, Deviation within high and low limits, De-energized on PV high limit, De-energized on PV low limit.

Alarm output: 2 points.

Setting ranges for PV alarm and deviation alarm:

PV alarm: -100.0 to 100.0% of measured input range
Deviation alarm: -100.0 to 100.0% of measured input range span

Alarm hysteresis width: 0.0 to 100.0% of measured input range span

Waiting action:

Waiting action can be set to make PV/deviation alarm stand-by during start-up until PV reaches the normal region.

Fault diagnostic alarm:

Input burnout, A/D conversion error, thermocouple reference junction compensation error.

FAIL output:

Software failure and/or hardware failure.
When in fail, retransmission output and alarm output become 0% or OFF.

● Display and Operation Function

PV display:

In 4-digit digital display of engineering unit

Setpoint display:

Various data, such as the setpoint (SP), are displayed by selection on the 4-digit digital display.

Status indicating lamps:

2 alarm indicator lamps: AL1, AL2
Exceeded lamp: Lit when PV exceeds SP
Output status lamp: Lit when output relay is de-energized.

Operation keys:

▲ and ▼ keys: Increase or decrease setpoints and various parameters.
SET/ENT key: For data setting or call-up/selection of various parameters.
RESET key: Confirms the limit status and resets the output.

Security function:

An operation-inhibiting mode using a password is provided.

■ Communication Specifications (optional)

This controller has a communication function and can be connected to a personal computer, programmable controllers or other GREEN Series controllers.

Communication protocol:

Computer link communication: Communication protocol with a personal computer.

Ladder communication: Communication protocol with programmable controller.

Communication interface:

Communication protocol: Computer link or ladder communication

Standards: EIA RS485

Maximum number of connectable controllers: 31 GREEN Series controllers

Maximum communication distance: 1,200 m

Communication method: Two-wire half duplex or four-wire half duplex, start-stop synchronization, non-procedural.

Communication rate: 600, 1200, 2400, 4800, 9600 bps

■ Hardware Specifications

● PV Input Signal

Number of input points : 1

Input system:

The types of input/measurement ranges can be set using software from a list of inputs.

Types of inputs, measurement ranges and measurement accuracy: Refer to the table on page 4.

Burnout detection:

Functions with a thermocouple (TC), RTD, standard signal 0.4 to 2 V, and 1 to 5 V.

Can be specified as upscale, downscale, and off. For standard signal, judged as burnout at 0.1 V or less.

Input bias current : 0.05 μ A (for TC/RTD)

Input resistance:

1 M Ω or more for TC/mV

About 1 M Ω for DC voltage input

Allowable signal source resistance:

250 Ω or less; effect of permissible signal source resistance 0.1 μ V/ Ω or less for TC/mV

2 k Ω or less; effect of permissible signal source resistance 0.01%/100 Ω or less for DC voltage

Allowable leadwire resistance:

Max. of 150 Ω /wire (resistance in each of three wires must be equal) for RTD.

However, 10 Ω /wire in the range of -150.0 to 150.0°C.

Effect of permissible leadwire resistance:

0.1°C/10 Ω or less

Allowable input voltage:

\pm 10 V DC for TC/mV/RTD

\pm 20 V DC for DC voltage

Noise rejection ratio:

Normal mode 40 dB (50/60 Hz) or more

Common mode 120 dB (50/60 Hz) or more

Reference-junction compensation error:

\pm 1.0°C (15 to 35°C), \pm 1.5°C (0 to 15°C, 35 to 50°C)

Applicable standards : JIS, IEC, or DIN for TC and RTD

Response time: 2 second or less, 63% (10 - 90%)

(The time required for transmission output to reach 63% of the maximum excursion when PV abruptly changes from 10% to 90%)

Retransmission Output

Either PV or target setpoint is output.
 Number of output points: 1
 Output signal: 4 to 20 mA DC
 Load resistance: 600 Ω or less
 Output accuracy: ± 0.3% of span

Control Output

The control output is a relay output.
 Number of output points : 1
 Output signal: Three terminals for NC, NO, and
 Common transfer-contacts
 Contact rating: 250 V AC, 3 A or 30 V DC, 3A (resistive
 load)
 Resolution: 10 ms

Contact Input

Usage: Confirmation of limit output
 Number of input points: 1
 Input type: Voltage-free contact input or transistor contact
 input
 Input contact rating: 12 V DC, 10 mA or more
 On/off determination:
 For contact input,
 ON = contact resistance of 1 kΩ or less,
 OFF = contact resistance of 20 kΩ or more.
 For transistor contact input,
 ON = 2 V or less,
 OFF = leakage current of 100 μA or less.
 Minimum retention time for status detection: 1 s

Contact Output

Usage: Alarm output and FAIL output
 Number of relay contact output points: 2
 Relay contact rating: 240 V AC, 1 A or 30 V DC, 1 A

● Display Specifications

PV display: 4-digit, 7-segment red LED; character height -
 20 mm
 Setpoint display: 4-digit, 7-segment red LED; character
 height - 9.3 mm
 Status indicating lamps : LEDs

● Conformance to Safety and EMC Standards

Safety: Complies with IEC/EN61010-1 (CE), approved by
 C22.2 No.61010-1, approved by UL508.
 Certified for FM-3810 and FM-3545.
 Installation category : CAT. II
 Pollution degree : 2 (IEC/EN61010-1, C22.2
 No.61010-1)
 Measurement category : I (CAT. I : IEC/
 EN61010-1)
 Rated measurement input voltage : 10V DC
 max.(across terminals), 300V AC max.(across
 ground)
 Rated transient overvoltage : 1500V (Note)
 Note : It is a value on the safety standard
 which is assumed by IEC/EN61010-1 in
 Measurement category I, and is not the value
 which guarantees an apparatus performance.
 EMC standards:Complies with EN61326, EN61000-3-2,
 EN61000-3-3 and EN55011 (CE).
 Class A Group 1.
 During test, the controller continues to operate
 with the measurement accuracy within ±20%
 of the range.

● Construction, Mounting, and Wiring

Construction: Front panel drip-proof (IP55 compatible)
 Material: ABS resin and polycarbonate
 Case color: Black
 Weight: Approx. 1 kg or less
 External dimensions: 96 (width) x 96 (height) x 100
 (depth) mm
 Mounting: Direct panel mounting; mounting bracket, one
 each for upper and lower mounting
 Panel cutout dimensions: 92^{+0.8}₀ (width) x 92^{+0.8}₀ (height)
 mm
 Mounting attitude: Up to 30 degrees above the horizontal.
 No downward tilting allowed.
 Wiring: M3.5 (ISO 3.5 mm) screw terminals (signal wiring
 and power/ground wiring as well)

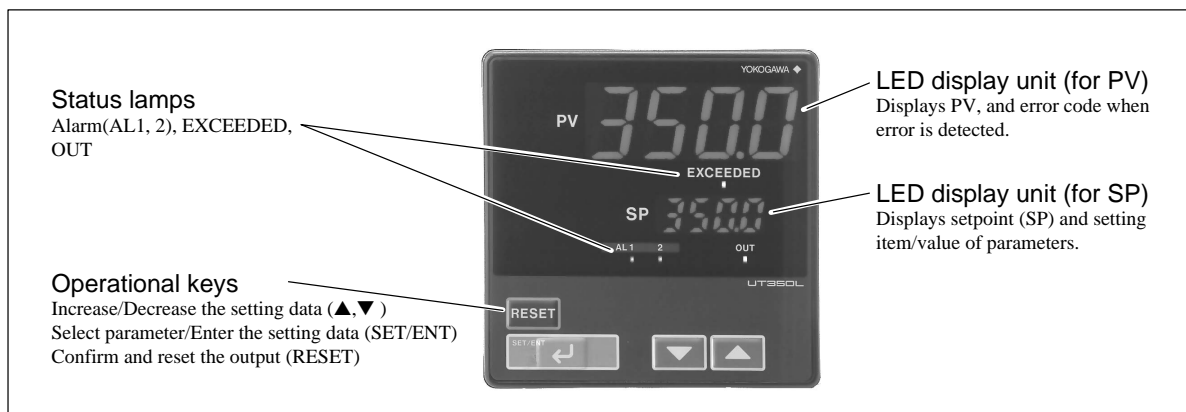

● Power Supply Specifications and Isolation

Power supply: Rated at 100 to 240 V AC ($\pm 10\%$), 50/60 Hz

Power consumption: Max. 20 VA (Max. 8.0 W)

Memory back-up: Non-volatile memory.

Withstanding voltage:

1500 V AC for 1 minute between primary and secondary terminals.

1500 V AC for 1 minute between primary and ground terminals.

1500 V AC for 1 minute between ground and secondary terminals.

500VAC for 1 minute between two secondary terminals.

(Primary terminals = power and relay output terminals)
(Secondary terminals = Analog I/O signal terminals, contact input terminals.)

Insulation resistance: 20 M Ω or more when 500 V DC voltage is applied between the power terminals and ground terminal.

Grounding: Class D grounding (grounding resistance of 100 Ω or less)

Isolation specifications

Measured input terminal: Isolated from other I/O terminals. Not isolated from internal circuits.

Analog 4 to 20 mA output (retransmission) terminal: Isolated from other I/O terminals and internal circuits.

Relay contact control output terminals: Isolated from other contact output terminals, other I/O terminals and internal circuits.

Contact input terminals: Not isolated from other contact input terminals, and communication terminals. Isolated from other I/O terminals and internal circuits.

Relay contact output terminals: Not isolated from other relay contact output terminals. Isolated from other I/O terminals and internal circuits.

RS-485 communication terminals: Not isolated from contact input terminals. Isolated from other I/O terminals and internal circuits.

Power supply terminals: Isolated from other I/O terminals, ground terminal, and internal circuits.

Ground terminal: Isolated from other I/O terminals, power terminals, and internal circuits.

Input type	Input range code	Instrument range (°C)	Instrument range (°F)	Measurement accuracy	
Thermocouple	K	1	-200 to 1370°C	-300 to 2500°F	At or above 0°C, $\pm 0.1\%$ ± 1 digit of F.S. Below 0°C, $\pm 0.2\%$ ± 1 digit of F.S.
		2	-199.9 to 999.9°C	0 to 2300°F	
		3	-199.9 to 500.0°C	-199.9 to 999.9°F	
	J	4	-199.9 to 999.9°C	-300 to 2300°F	
	T	5	-199.9 to 400.0°C	-300 to 750°F	
		6	0.0 to 400.0°C	-199.9 to 750.0°F	
	B	7	0 to 1800°C	32 to 3300°F	At or above 400°C, $\pm 0.15\%$ ± 1 digit of F.S. Below 400°C, $\pm 5\%$ ± 1 digit of F.S.
	S	8	0 to 1700°C	32 to 3100°F	$\pm 0.15\%$ ± 1 digit of F.S.
	R	9	0 to 1700°C	32 to 3100°F	
	N	10	-200 to 1300°C	-300 to 2400°F	$\pm 0.1\%$ ± 1 digit of F.S.
	E	11	-199.9 to 999.9°C	-300 to 1800°F	At or above 0°C, $\pm 0.1\%$ ± 1 digit of F.S.
	L (DIN)	12	-199.9 to 900.0°C	-300 to 1300°F	Below 0°C, $\pm 0.2\%$ ± 1 digit of F.S.
	U (DIN)	13	-199.9 to 400.0°C	-300 to 750°F	
		14	0.0 to 400.0°C	-199.9 to 750.0°F	
	W (DIN)	15	0 to 2300°C	32 to 4200°F	$\pm 0.2\%$ ± 1 digit of F.S.
	Platinel 2	16	0 to 1390°C	32 to 2500°F	$\pm 0.1\%$ ± 1 digit of F.S.
	PR20-40	17	0 to 1900°C	32 to 3400°F	At or above 800°C, $\pm 0.5\%$ ± 1 digit of F.S. Below 800°C, not guaranteed
	W97Re3-W75Re25		0 to 2000°C	32 to 3600°F	$\pm 0.2\%$ ± 1 digit of F.S.
RTD	JPt100	30	-199.9 to 500.0°C	-199.9 to 999.9°F	$\pm 0.1\%$ ± 1 digit of F.S.
		31	-150.0 to 150.0°C	-199.9 to 300.0°F	$\pm 0.2\%$ ± 1 digit of F.S.
	Pt100	35	-199.9 to 640.0°C	-300 to 1180°F	$\pm 0.1\%$ ± 1 digit of F.S.
		36	-199.9 to 500.0°C	-199.9 to 999.9°F	
		37	-150.0 to 150.0°C	-199.9 to 300.0°F	$\pm 0.2\%$ ± 1 digit of F.S.
Standard signal	0.4 to 2V	40	0.400 to 2.000	Scaling is enable in the following 4 range. -1999 to 9999 -199.9 to 999.9 -19.99 to 99.99 -1.999 to 9.999	$\pm 0.1\%$ ± 1 digit of F.S.
	1 to 5V	41	1.000 to 5.000		
DC voltage	0 to 2V	50	0.000 to 2.000		
	0 to 10V	51	0.00 to 10.00		
	-10 to 20mV	55	-10.00 to 20.00		
	0 to 100mV	56	0.0 to 100.0		

● Environmental Conditions

Normal operating conditions:

- Ambient temperature: 0 to 50°C (40°C or less for mounting of instruments side-by-side)
- Temperature fluctuation: Max. 10°C/h
- Ambient humidity: 20 to 90% RH (no condensation)
- Magnetic field: 400 A/m or less
- Continuous vibration (5 to 14 Hz): Peak-to-peak amplitude of 1.2 mm or less
- Continuous vibration (14 to 150 Hz): 4.9 m/s² (0.5G) or less
- Short-period vibration: 14.7 m/s² (1.5G), 15s or less
- Shock: 147 m/s² (15G) or less, 11 ms
- Installation altitude: 2,000 m or less above sea level
- Attitude for installation: Max. 30° off vertical. Do not install upside-down.
- Installation category based on IEC61010-1: II (See Note.)
- Pollution degree based on IEC61010-1: 2 (See Note.)

Note:

- The “Installation category” implies the regulation for impulse withstand voltage. It is also called the “Overvoltage category.” “II” applies to electrical equipment.
- “Pollution level” describes the degree to which a solid, liquid or gas which deteriorates dielectric strength is adhering. “2” applies to a normal indoor atmosphere.

Transportation and storage conditions:

- Temperature : -25 to 70°C
- Humidity : 5 to 95% RH

Effects of operating conditions:

Effect of ambient temperature:

For voltage or TC inputs: Whichever is greater,
 $\pm 1\mu\text{V}/^\circ\text{C}$ or $\pm 0.01\%$ of F.S./ $^\circ\text{C}$

For RTD inputs: $\pm 0.05^\circ\text{C}/^\circ\text{C}$ or less for RTD input

For analog output: $\pm 0.05\%$ of F.S./ $^\circ\text{C}$ or less

Effect of power supply fluctuation (within rated voltage range):

For analog input: Equal to or less than whichever is greater, $\pm 1\mu\text{V}/10\text{V}$ or $\pm 0.01\%$ of F.S./10 V

For analog output: $\pm 0.05\%$ of F.S./10 V or less

Terminal Wiring Diagrams

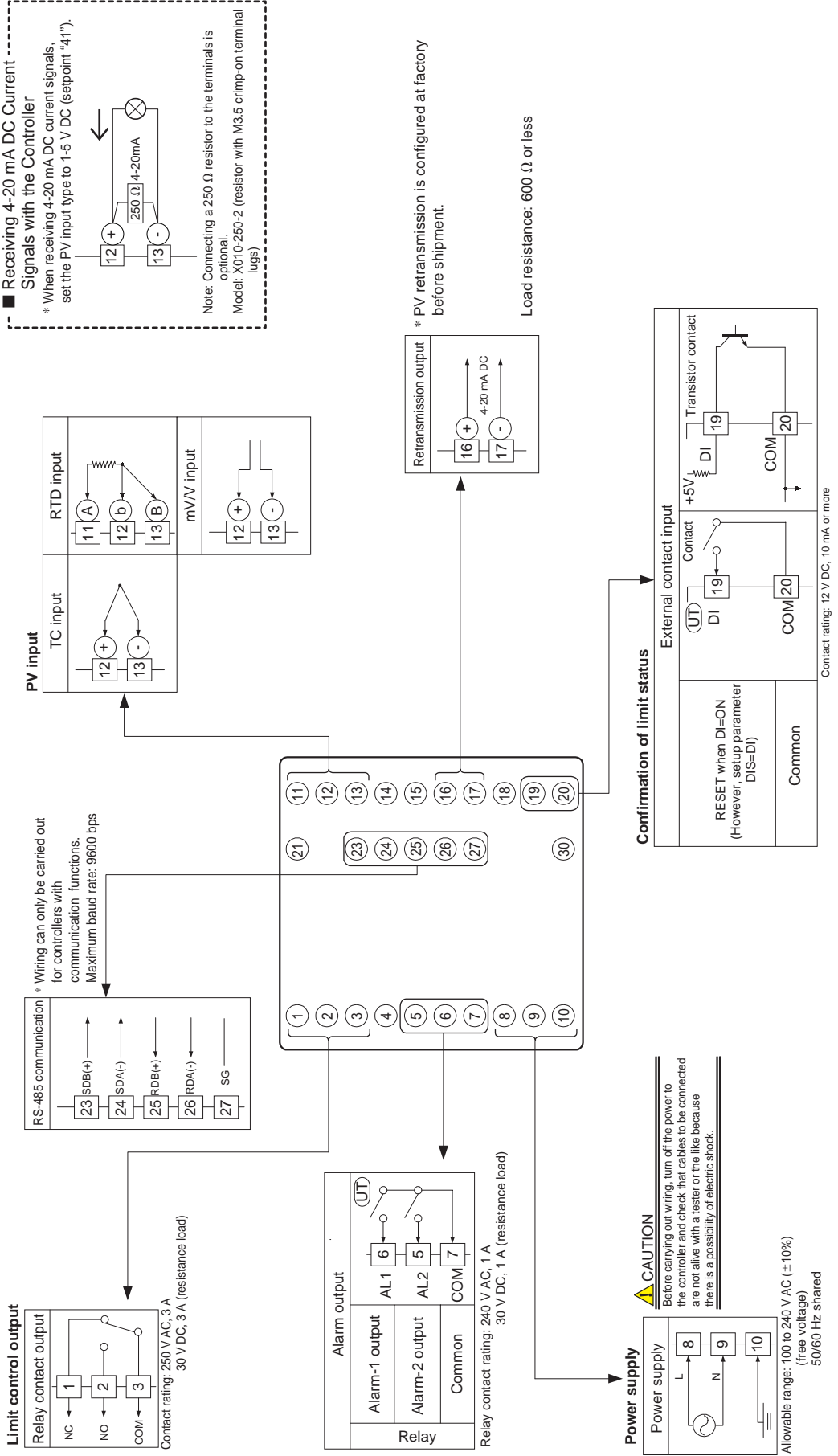

External Dimensions and Panel Cutout Dimensions

Unit: mm

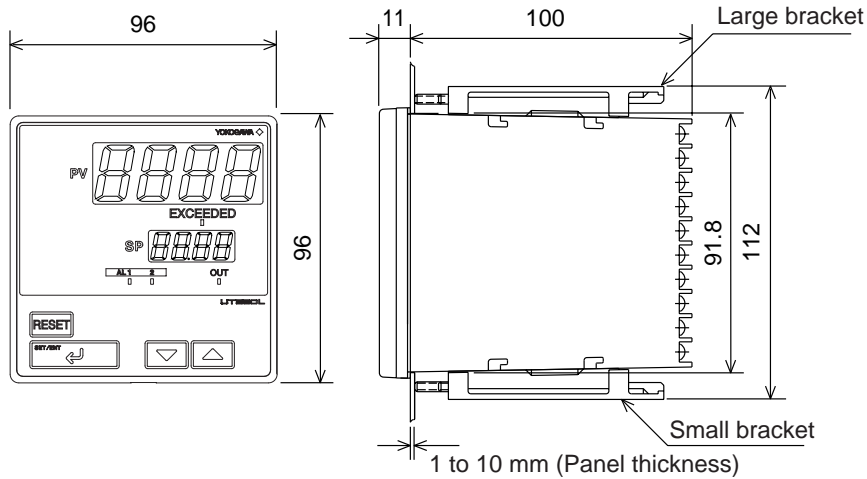

General installation

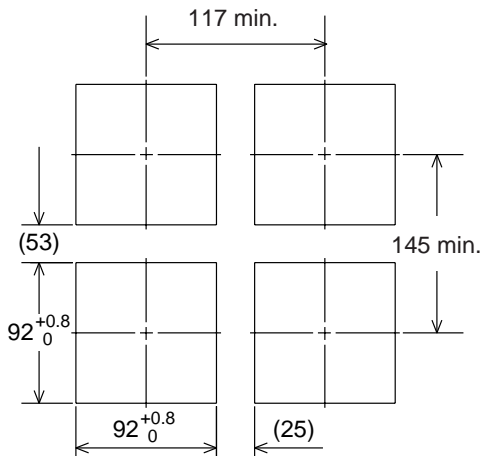

Side-by-side close installation

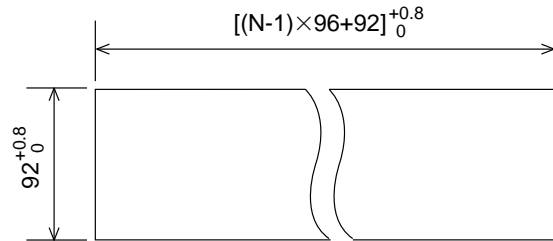

"N" stands for the number of controllers to be installed.
However, the measured value applies if $N \geq 5$.

Normal Allowable Deviation = \pm (Value of JIS B 0401-1999 tolerance grade IT18) / 2

Model and Suffix Codes

Model	Suffix code	Description
UT350L		Limit controller
Type	-0	Standard type
Optional functions	0	None
	1	With communication

Standard Accessories: User's manual, mounting bracket

Items to be Specified when Ordering

Model and suffix codes