

# E112-P

**EXPLOSION PROOF FLOWRATE INDICATOR / TOTALIZER**  
**with LINEARIZATION**



**Signal input flowmeter: pulse, NAMUR and coil**

**Signal outputs: Analog referenced flowrate and pulse referenced total**

**Remote control: External reset with clear-lock**

**Options: Modbus Communication, USB Communication**



## SAFETY INSTRUCTIONS



- Any responsibility is lapsed if the instructions and procedures as described in this manual are not followed.
- **LIFE SUPPORT APPLICATIONS:** The E112-P is not designed for use in life support appliances, devices, or systems where malfunction of the product can reasonably be expected to result in a personal injury. Customers using or selling these products for use in such applications do so at their own risk and agree to fully indemnify the manufacturer and supplier for any damages resulting from such improper use or sale.
- Electro static discharge does inflict irreparable damage to electronics! Before installing or opening the E112-P, the installer has to discharge himself by touching a well-grounded object.
- The E112-P must be installed in accordance with the EMC guidelines (Electro Magnetic Compatibility).
- Do connect a proper grounding to the housing as indicated if the E112-P is used on a ship, truck or other application with no ground. The earth lead between the housing and the removable terminal-block may never be removed.

## DISPOSAL OF ELECTRONIC WASTE



- At the end of its life this product should be disposed of according to the (inter)national regulations regarding waste electronic equipment. If a battery is installed in this product it should be disposed of separately. The separate collection and recycling of your waste equipment will help to conserve natural resources and ensure that it is recycled in a manner that protects the environment

## SAFETY RULES AND PRECAUTIONARY MEASURES

- The manufacturer accepts no responsibility whatsoever if the following safety rules and precautions instructions and the procedures as described in this manual are not followed.
- Modifications of the E112-P implemented without preceding written consent from the manufacturer, will result in the immediate termination of product liability and warranty period.
- Installation, use, maintenance and servicing of this equipment must be carried out by authorized technicians.
- Check the mains voltage and information on the manufacturer's plate before installing the E112-P.
- Check all connections, settings and technical specifications of the various peripheral devices with the E112-P supplied.
- Never open the enclosure in hazardous areas while connected to power supplying or consuming devices other than the internal battery supply.
- Open the E112-P only if all leads are free of potential.
- Never touch the electronic components (ESD sensitivity).
- Never expose the system to heavier conditions than allowed according to the enclosure classification (see manufacture's plate and chapter 4.2.).
- If the operator detects errors or danger, or disagrees with the safety precautions taken, then inform the owner or principal responsible.
- The local labor and safety laws and regulations must be adhered to.

## ABOUT THE OPERATION MANUAL

This operation manual is divided into two main sections:

- The daily use of the E112-P is described in chapter 2 “Operational”. These instructions are meant for users.
- The following chapters and appendices are exclusively meant for electricians/technicians. These provide a detailed description of all software settings and hardware installation guidance.

This operation manual describes the standard E112-P as well as most of the options available. For additional information, please contact your supplier.

**A hazardous situation may occur if the E112-P is not used for the purpose it was designed for or is used incorrectly. Please carefully note the information in this operating manual indicated by the pictograms:**



A "**warning !**" indicates actions or procedures which, if not performed correctly, may lead to personal injury, a safety hazard or damage of the E112-P or connected instruments.



A "**caution !**" indicates actions or procedures which, if not performed correctly, may lead to personal injury or incorrect functioning of the E112-P or connected instruments



A "**note !**" indicates actions or procedures which, if not performed correctly, may indirectly affect operation or may lead to an instrument response which is not planned.

Hardware version : 13.02.xx

Software version : 03.05.xx

Manual : TU-E112-P-M\_v0102\_13\_EN

© Copyright 2018 : Fluidwell B.V. – The Netherlands.

Information in this manual is subject to change without prior notice. The manufacturer is not responsible for mistakes in this material or for incidental damage caused as a direct or indirect result of the delivery, performance or use of this material.

© All rights reserved. No parts of this publication may be reproduced or used in any form or by any means without written permission of your supplier.

# CONTENTS MANUAL

<b>SAFETY INSTRUCTIONS .....</b>	<b>2</b>
<b>DISPOSAL OF ELECTRONIC WASTE.....</b>	<b>2</b>
<b>SAFETY RULES AND PRECAUTIONARY MEASURES .....</b>	<b>2</b>
<b>ABOUT THE OPERATION MANUAL.....</b>	<b>3</b>
<b>CONTENTS MANUAL .....</b>	<b>4</b>
<b>1 INTRODUCTION.....</b>	<b>5</b>
1.1 System description of the E112-P .....	5
<b>2 OPERATIONAL .....</b>	<b>7</b>
2.1 General information .....	7
2.2 Control panel.....	7
2.3 Operator information and functions .....	9
2.4 Operator Alarms.....	10
<b>3 CONFIGURATION .....</b>	<b>11</b>
3.1 Introduction .....	11
3.2 Programming SETUP-level.....	11
<b>4 INSTALLATION.....</b>	<b>24</b>
4.1 General directions.....	24
4.2 Installation / surrounding conditions .....	24
4.3 Dimensions – Enclosure .....	25
4.4 Installing the hardware.....	26
4.5 Terminal connectors – Main Electronics Module .....	31
4.6 Terminal Connections .....	32
<b>5 MAINTENANCE.....</b>	<b>38</b>
5.1 General directions.....	38
5.2 instructions for repair .....	38
5.3 Open and close the E-Series.....	39
5.4 Battery replacement – Supply module (if installed) .....	39
<b>6 LABEL INFORMATION .....</b>	<b>42</b>
6.1 General remarks regarding the shown labels .....	42
6.2 Label with certification data .....	42
6.3 Label with thread sizes. ....	42
6.4 Internal Labels. ....	43
<b>APPENDIX A. TECHNICAL SPECIFICATION .....</b>	<b>44</b>
<b>APPENDIX B. PROBLEM SOLVING.....</b>	<b>47</b>
<b>APPENDIX C. MODBUS COMMUNICATION.....</b>	<b>48</b>
<b>APPENDIX D. DECLARATION OF CONFORMITY.....</b>	<b>54</b>
<b>INDEX OF THIS MANUAL.....</b>	<b>55</b>
<b>LIST OF FIGURES E112-P.....</b>	<b>56</b>
<b>NOTES ABOUT THE E112-P .....</b>	<b>57</b>

# 1 INTRODUCTION

## 1.1 SYSTEM DESCRIPTION OF THE E112-P

### Functions and features

The flowrate / totalizer model E112-P is an explosion proof microprocessor driven instrument designed to linearize the flowmeter's flow curve and to show the flowrate, the total and the accumulated total.

This product has been designed with a focus on:

- User-friendliness: operation through the glass without removing the cover.
- Good readings in full sunlight and darkness through a bright backlight.
- Mounting flexibility: multiple solutions for sensor mounting, including 1" NPT or M25 bottom entry as well as suitable for wall or pipe mount applications.
- Ruggedness for harsh surrounding: not just designed to be explosion proof.
- Usability: wide operational temperature, high ingress protection rating and international certification.
- Installation friendly design: spacious cabling area, plug and play cable connection and easy removable electronic module.
- Aluminum enclosure with high quality industrial two component coating.
- Stainless steel 316L enclosure available for offshore applications.
- Ability to process any type of sensor signal,
- Multiple power supply options to suit any application, including long-life battery supply.
- Configurable pulse and analog signal outputs and optional communication outputs.

### Flowmeter input

This manual describes the E112-P with a pulse type input from the flowmeter "-P version". Other versions are available to process (0)4-20mA flowmeter signals.

One flowmeter with a passive or active pulse, NAMUR or coil signal output can be connected to the E112-P. To power the sensor, several options are available.

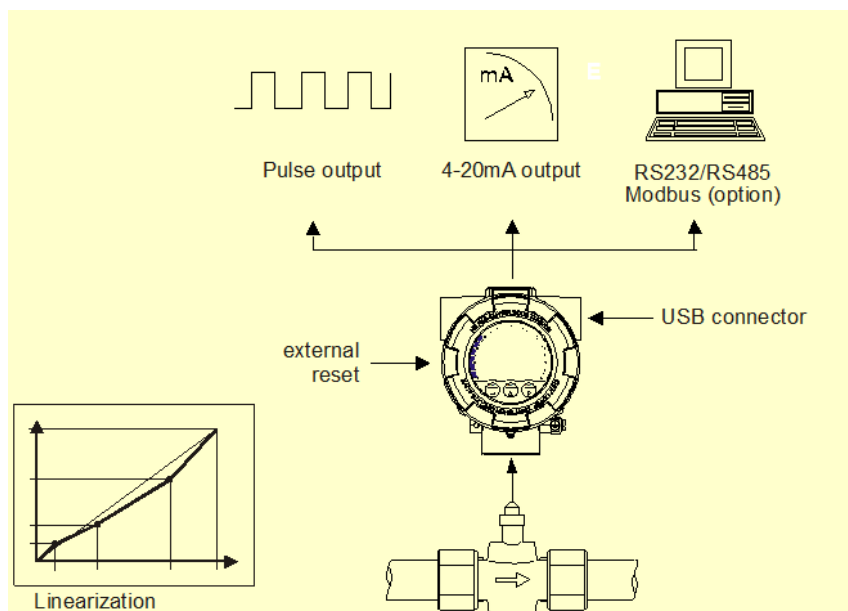

Fig. 1: Application lay-out (typical)

### Standard outputs

- Configurable pulse output: a scaled pulse representing a certain linearized total quantity. Maximum frequency 500Hz. The pulse length can be set as desired.
- Configurable linear 4-20mA isolated analog output with 12-bits resolution representing the actual linearized flowrate. Flowrate levels as well as the minimum and maximum signal output can be tuned.

### **Configuration**

The E112-P has been designed to be implemented in many types of applications. For that reason, a SETUP-level is available to configure your E112-P according to your specific requirements. It includes several important features, such as K-Factor, measurement units, signal selection etc. All settings are stored in an EEPROM memory and will not be lost in the event of a power failure or a drained battery.

To extend the battery-life time, please use of the power-management functions as described in chapter 3.

### **Display information**

The E112-P has a large LCD with all kinds of symbols and digits to display measurement units, status information, trend-indication and key-word messages.

Flowrate and totals can be displayed either with the 11 small 7mm (0.28") digits or with the 7 large 12mm (0.47") digits. Additionally, the E112 has an analog speedometer to show the actual flowrate.

### **Backlight**

A backlight is standard available. The intensity can be set as desired (externally powered only).

The backlight can even be used in battery powered applications: it will be switched on, at a fixed intensity, during a limited period of time and will switch off automatically, 3 seconds after a key touch.



Note !

*For loop powered applications only, the backlight will not come on because of limited power.*

### **Options**

The following options are available: full Modbus communication RS232/485 or USB (also battery powered), data logging, mechanical relay or active outputs, power- and sensor-supply options.

## 2 OPERATIONAL

### 2.1 GENERAL INFORMATION

This chapter describes the daily use of the E112-P. This instruction is meant for users / operators.



Caution !

- The E112-P may only be operated by personnel who are authorized and trained by the operator of the facility. All instructions in this manual are to be observed
- Take careful notice of the “Safety rules, instructions and precautionary measures” in the front of this manual.

### 2.2 CONTROL PANEL

The optical keys are operated through the glass. The following keys are available:



Fig. 2: Control panel, optical keys.

#### Functions of the keys



This key is used to program and save new values or settings.  
It is also used to gain access to SETUP-level; please read chapter 3.



This key is used to SELECT accumulated total.  
The arrow-key ▲ is used to increase a value after PROG has been pressed or to configure the unit; please read chapter 3.



Press this key twice to CLEAR the value for total.  
The arrow-key ► is used to select a digit after PROG has been pressed or to configure the E112-P; please read chapter 3.

#### Use of optical keys

The optical keys are designed to operate stable and will not be activated when the glass surface is not clean. Keep the glass surface clean to avoid false key activations (false activations reduce battery lifetime). Also do not mount objects within 100mm in the front of the product (shiny surfaces could cause false activations). It is not necessary to touch the glass for activation. Activating by touching the clean glass surface normally also works fine, but in case of detection problems try not to touch the glass.

#### Unlock optical keys

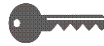
The optical keys are disabled after 30 seconds when enabled at SETUP 9.5. A key lock symbol  will appear at the top of the display to indicate this.

To enable the optical keys, touch briefly after each other all three keys in the following order:  
PROG – SELECT – CLEAR.

The display will hint this sequence. The key lock symbol will disappear when the sequence is successfully executed.

**Disable optical keys**

To disable the optical keys touch simultaneously the PROG and CLEAR keys for 3 seconds (or wait for 30 seconds). The key lock symbol will appear as shown.

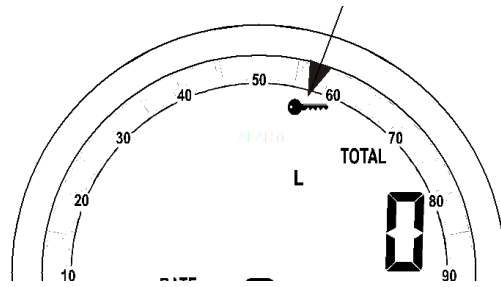

Fig. 3: Control panel, disable optical keys.

**Enable or disable optical keys with on-off switch**

Under the optical keys an on-off switch is located to enable or disable the optical keys. Move this switch to the right to enable or to the left to disable the optical keys. The key lock symbol will appear in the display.

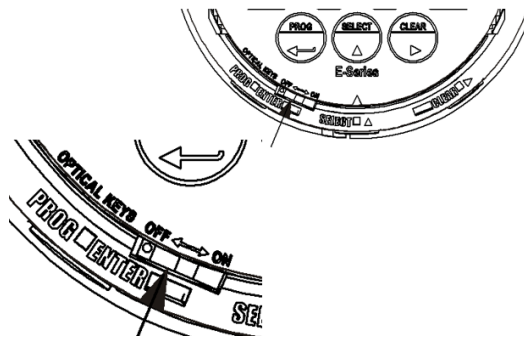

Fig. 4: Control panel, ON/OFF optical keys.



*For battery powered applications it is recommended to switch off the optical keys when possible to save on power consumption significantly.*

**Push button operation**

Next to the three optical keys also three push buttons are available when the cover is removed. Make sure the key lock is active before removing the cover to prevent unwanted actions.

On the side of the collar of the display three black mechanical push buttons are present in the same order as the optical keys, PROG/ENTER – SELECT – CLEAR. They operate in the same manner as the optical keys.

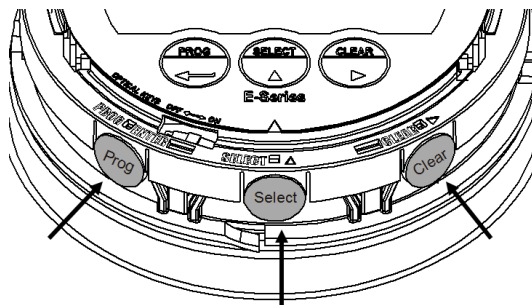

Fig. 5: Control panel, Push button operation.

## 2.3 OPERATOR INFORMATION AND FUNCTIONS



Note !

Check the key lock and unlock before operation

Unlock the optical keys as described before.

By default, the E112-P will act at Operator level. The information displayed is dependent upon the SETUP-settings. Signals generated by the connected flowmeter are measured by the E112-P in the background. The display values are however updated depending on the selected refresh rate. After pressing a key, the display will be refreshed 8 times per second, after 30 seconds it will return to the selected setting.

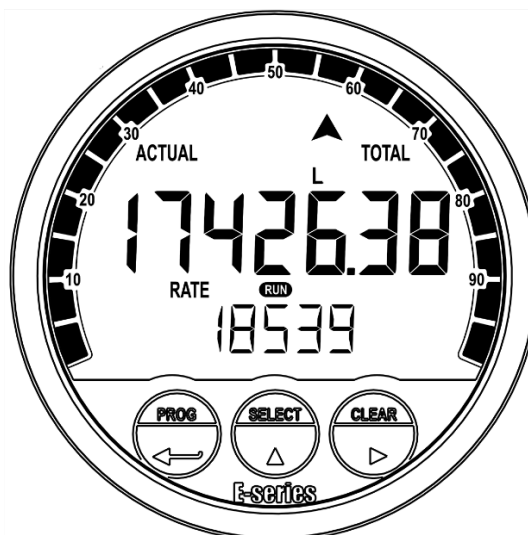

Fig. 6: Example of display information during process.

For the Operator, the following functions are available:

- **Display flowrate / total or flowrate**

This is the main display information of the E112-P. After selecting any other information, it will always return to this main display automatically.

Total is displayed on the upper-line of the display and flowrate on the bottom line.

It is possible to display flowrate only with the large 12mm digits; in this instance press the SELECT-key to read the total. When "-----" is shown, the flowrate value is too high to be displayed. The arrows  $\blacktriangle$  indicate the increase/decrease of the flowrate trend.

- **Clear total**

The value for total can be re-initialized. To do so, press CLEAR twice. After pressing CLEAR once, the flashing text "PUSH CLEAR" is displayed. To avoid re-initialization at this stage, press another key than CLEAR or wait for 20 seconds.

Re-initialization of total DOES NOT influence the accumulated total.

A password might be required to reset Total.



Note !

The IB option (external keyboard) allows clear total also via an external pushbutton. This clear operates in parallel with the clear action via the control panel but does not require an extra confirmation. When the switch is closed, Total still counts but the "Clear Total" function is disabled.

- **Display accumulated total**

When the SELECT-key is pressed, total (upper line) and accumulated total (lower line) are displayed. The accumulated total cannot be reset. The value will count up to 99.999.999.999. The unit and number of decimals are displayed according to the configuration settings for total. After 20 seconds the default display mode is restored.

- **Display speedometer flowrate**

The display shows along the edge a percent based impression of the actual flowrate. The speedometer consists of 20 segments which run from 0 to 100%. This function can be enabled or disabled in the setup menu Display.

## 2.4 OPERATOR ALARMS

### Low-battery alarm (PB only)

During operation the battery voltage drops. When the battery voltage becomes too low, the battery indicator comes on to show that the operation and indication become less reliable. When the battery indicator is on, install a fresh and new battery (as soon as possible) to keep a reliable operation and indication.



Note !

*Only use original batteries. Original batteries can be ordered at the manufacturer. The use of unapproved batteries will void the warranty.*

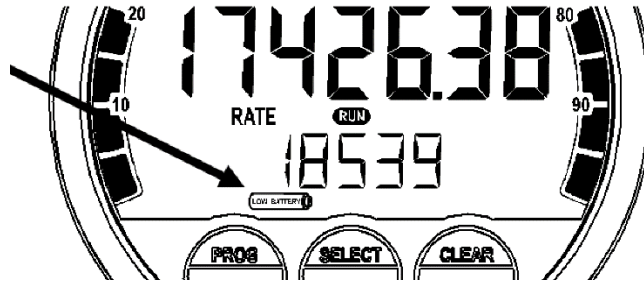

Fig. 7: Example of low-battery alarm.

### Alarm

When “alarm” is displayed, see Appendix B: Problem solving.

### 3 CONFIGURATION

#### 3.1 INTRODUCTION

This and the following chapters are exclusively meant for electricians and non-operators. In these, an extensive description of all software settings and hardware connections are provided.



Caution !

- Mounting, electrical installation, start-up and maintenance of the instrument may only be carried out by trained personnel authorized by the operator of the facility. Personnel must read and understand this manual before carrying out its instructions.
- The E112-P may only be operated by personnel who are authorized and trained by the operator of the facility. All instructions in this manual are to be observed.
- Ensure that the measuring system is correctly wired up according to the wiring diagrams. The housing may only be opened by authorized personnel.
- Take careful notice of the “Safety rules, instructions and precautionary measures” in the front of this manual.

#### 3.2 PROGRAMMING SETUP-LEVEL



Note !

*Be aware that the optical keys may be locked and will not function. Unlock the optical keys as described before.*

##### 3.2.1 GENERAL INFORMATION

Configuration of the E112-P is done at SETUP level. SETUP level is reached by pressing the PROG/ENTER key for 7 seconds; at which time  will be displayed. To return to the operator level, press PROG for three seconds or do not press any key for 2 minutes, the unit will exit SETUP automatically.

SETUP can be reached at all times while the E112-P remains fully operational. Be aware that in this case any change to the settings may have an influence on the operation. The ‘setup’ indicator will be activated and the ‘run’ indicator will be deactivated.



Note !

*A password may be required to enter SETUP. Without this password access to SETUP is denied.*

#### To enter SETUP-level

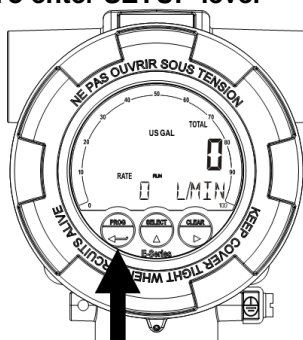

Press the PROG/ENTER key for 7 seconds.

#### Matrix structure SETUP-level

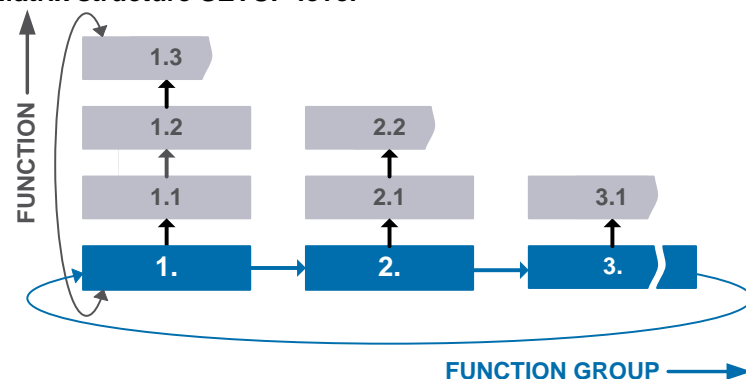

Each function has a unique number, which is displayed below the word “SETUP” at the bottom of the display. The number is a combination of two figures. The first figure indicates the function-group and the second figure the sub-function. Additionally, each function is expressed with a keyword.

FW-4100-000001-001-EN

After selecting a sub-function, the next main function is selected by scrolling through all “active” sub-functions (e.g. 1<sup>▲</sup>, 1.1<sup>▲</sup>, 1.2<sup>▲</sup>, 1.3<sup>▲</sup>, 1.4<sup>▲</sup>, 1<sup>▶</sup>, 2<sup>▶</sup>, 3<sup>▲</sup>, 3.1 etc.).

Scroll back a function group is done by pressing PROG (e.g. 4<sup>◀</sup>, 3<sup>◀</sup>, 2<sup>◀</sup>, 1<sup>◀</sup>)

Scroll back a sub-function is done by pressing CLEAR (e.g. 1.4<sup>▶</sup>, 1.3<sup>▶</sup>, 1.2<sup>▶</sup>, 1.1<sup>▶</sup>)

**SCROLLING THROUGH SETUP-LEVEL**

**Selection of function-group and function**

SETUP is divided into several function groups and functions.

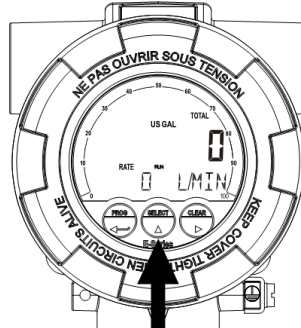
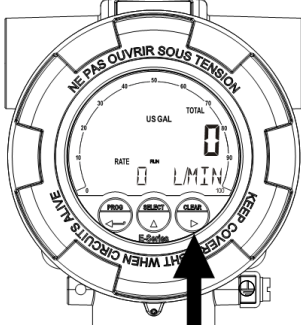

Select the function group with the CLEAR/▶ key.

Select the function with the SELECT/▲ key.

**To change or select a value**

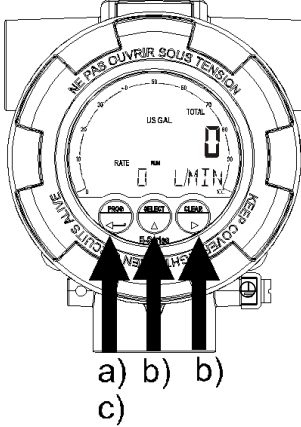

- Momentarily, press the PROG/ENTER key. The program indicator start to flash.
- Select or enter a value with the SELECT/▲ key and/or the CLEAR/▶ key.
- Press the PROG/ENTER key to confirm the value/selection.
- To change a value, use ▶ to select the digits and ▲ to increase that value.

If the new value is invalid, the increase sign ▲ or decrease-sign ▼ will be displayed while you are programming.

To select a setting, ▲ is used to select in one direction and ▶ can be used to select in the other direction.

When data is altered but ENTER is not pressed, then the alteration can still be cancelled by waiting for 20 seconds or by pressing ENTER for three seconds: the PROG-procedure will be left automatically and the former value reinstated.



Note !

*Alterations will only be set after ENTER has been pressed!*

**To return to OPERATOR-level**

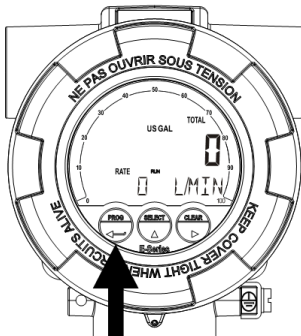

Press the PROG/ENTER key for 3 seconds.

In order to return to the operator level, PROG will have to be pressed for three seconds. Also, when no keys are pressed for 2 minutes, SETUP will be left automatically

## 3.2.2 OVERVIEW FUNCTIONS SETUP LEVEL

1 TOTAL		
1.1	UNIT	L – m3 – US gal – l gal – cf – oil bbl – kg – ton – US ton – lb – (none)
1.2	DECIMALS	0, 0.1, 0.02, 0.003
1.3	K-FACTOR	AUTO, 0000010 – 9999999
1.4	K-FACTOR DECIMALS	AUTO, 0 – 6
1.5	FACTOR-X	x1 – x10 – x100 – x1000
1.6	CLEAR PASSWORD	000 - 999
2 FLOWRATE		
2.1	UNIT	mL – L – m3 – mg – g – kg – ton – US ton – US gal – l gal – Oil bbl – lb – cf – rev – none – scf - nm3 – nL – p
2.2	TIME	/sec - /min - /hour - /day
2.3	DECIMALS	0, 0.1, 0.02, 0.003
2.4	K-FACTOR	AUTO, 0000010 – 9999999
2.5	K-FACTOR DECIMALS	AUTO, 0 – 6
2.6	CALCULATION	per 1 – 255 pulses
2.7	CUT-OFF	0.1 – 999.9 seconds
3 DISPLAY		
3.1	FUNCTION	total – flowrate – acc. total
3.2	LCD NEW	fast – 1 sec – 3 sec – 15 sec – 30 sec – off
3.3	BACKLIGHT	backlight brightness 0% - 20% - 40% - 60% - 80% - 100%
3.4	BARGRAPH	enable / disable
3.5	RATESPAN	0000000 – 9999999
4 FLOWMETER		
4.1	SIGNAL	NPN – NPN_LP – REED – REED_LP – PNP – PNP_LP – NAMUR – Coil_Hi – Coil_Lo – Act_8.2 (8.2V DC) – Act_24 (24V DC)
4.2	UNITS	hand, auto-vol, auto-mas
4.3	UNIT	Auto-vol: L – m3 – US GAL – lGAL – cf – oil bbl Auto mas: - kg – ton – US ton – lb
4.4	K-FACTOR	0.000010 – 9999999
4.5	K-FACTOR DECIMALS	0 – 6
5. LINEARIZE		
5.1	FREQ. / M-FACTOR 1	0000.1 – 9999.9 Hz / 0.000001 – 9.999999
5.2	FREQ. / M-FACTOR 2	0000.1 – 9999.9 Hz / 0.000001 – 9.999999
5.3	FREQ. / M-FACTOR n	0000.1 – 9999.9 Hz / 0.000001 – 9.999999
↑	↑	↑
5.F	FREQ. / M-FACTOR 15	0000.1 – 9999.9 Hz / 0.000001 – 9.999999
5.G	LINEARIZATION	enable / disable
5.H	DECIMALS FREQUENCY	0, 0.1, 0.02, 0.003
6 ANALOG		
6.1	OUTPUT	enable / disable
6.2	RATE-MIN (4mA)	0000000 – 9999999
6.3	RATE-MAX (20mA)	0000000 – 9999999
6.4	CUT-OFF	0.0 – 9.9%
6.5	TUNE-MIN (4mA)	0000 – 9999

	6.6	TUNE-MAX (20mA)	0000 – 9999
	6.7	FILTER	1 – 99
<b>7</b>	<b>PULSE</b>		
	7.1	WIDTH	0.000 – 9.999
	7.2	DECIMALS	0, 0.1, 0.02, 0.003
	7.3	AMOUNT	0000000 – 9999999
<b>8</b>	<b>COM-MODB</b>		
	8.1	SPEED	1200 – 2400 – 4800 – 9600 – 9600HP – 19200HP – 38400HP
	8.2	ADDRESS	001 – 247
	8.3	MODE	Off – bus asc – bus rtu
	8.4	DATABITS	8 bits, 7 bits
	8.5	PARITY	None, even, odd
<b>9</b>	<b>DATALOG (option)</b>		
		<i>Note ! For detailed information, refer to the manual E-series – Data logging.</i>	

**For E112-P without data logging**

<b>9</b>	<b>OTHERS</b>		
	9.1	MODEL	E112-P
	9.2	SOFTWARE VERSION	xx.xx.xx
	9.3	SERIAL NO	xxxxxxx
	9.4	PASSWORD	0000 – 9999
	9.5	KEY LOCK	enable / disable
	9.6	TAG NO	0000000 – 9999999

**For E112-P with data logging**

<b>10</b>	<b>OTHERS</b>		
	10.1	MODEL	E112-P
	10.2	SOFTWARE VERSION	xx.xx.xx
	10.3	SERIAL NO	xxxxxxx
	10.4	PASSWORD	0000 – 9999
	10.5	KEY LOCK	enable / disable
	10.6	TAG NO	0000000 – 9999999

**3.2.3 EXPLANATION OF SETUP-MENU – AUTOMATIC UNIT CONVERSION**

For a detailed description and instruction, refer to the E-series tutorial – Automatic unit conversion on the [Website](#). The automatic unit conversion is a feature that simplifies the configuration of your E112-P. It avoids different K-Factor calculations for (accumulated) total and the flowrate. To use the automatic unit conversion, you only need to enter the (average) K-Factor and the related measurement unit. These can be found on the test/calibration certificate that came with your flowmeter.

Procedure:

- First, select the type of measurement unit according to your certificate: volume, mass or hand (SETUP 4.2). Hand is selected for measurement units which are not supported by the automatic unit conversion, for example volume and mass units simultaneously. By default, the unit conversion is set to auto volume.
- Now, select the measuring unit that is used on your flowmeter certificate – SETUP 4.3.
- Finally, enter the certificates average K-factor (SETUP 4.4) and the belonging decimal position (SETUP 4.4)



After above procedure, you only need to select the desired measuring units for (acc.) Total (SETUP 1.1) and Flowrate (SETUP 2.1). This can be any volumetric or mass unit within the range – the conversion is done automatically.



Note !

*The actual totals are NOT recalculated!*







## 3.2.4 EXPLANATION OF SETUP MENU 1 - TOTAL



1		TOTAL	
1.1	UNIT	 Note !	<p>First set the flowmeter unit at SETUP 4.2. It has a direct influence on this Total unit setting. Change of the type of flowmeter unit (SETUP 4.3) will cause this Total unit to jump to the default setting of the new flowmeter unit type.</p> <p>Setup 1.1. determines the measurement unit for (accumulated) total and pulse output. The measurement units which are available, are controlled from the UNITS which are selected in the flowmeter menu.</p> <p>AUTO-VOL: L – m3 – US gal – l gal – cf – Oil bbl;            AUTO-MAS: kg – ton – US ton – lb;            Hand: l – m3 – US gal – l gal – cf – Oil bbl – kg – ton – US ton – lb - ---- (no unit).</p>
1.2	DECIMALS		<p>The decimal point determines for Total and accumulated Total the number of digits following the decimal point.</p> <p>The following can be selected:            0, 0.1, 0.02, 0.003</p>
		 Caution !	<p><b>The next two menu items can be modified only if the automatic unit conversion in SETUP 4.2, Flowmeter-units, is set to Hand. Else, the display will show “AUTO”.</b></p>
1.3	K-FACTOR		<p>With the Total K-Factor, the flowmeter pulse signals are converted to a total unit. The Total K-Factor is based on the number of pulses generated by the flowmeter per selected measurement unit (SETUP 1.1).. The more accurate the Total K-Factor, the more accurate the functioning of the system will be.</p>
1.4	K-FACTOR DECIMALS	 Note !	<p>This setting determines the number of decimals for the Total K-Factor entered (SETUP 1.3).</p> <p>The following can be selected:            0 – 1 – 2 – 3 – 4 – 5 – 6</p> <p><i>This setting influences the accuracy of the total K-Factor indirectly (i.e. the position of the decimal point and thus the value given).            This setting has NO influence on the displayed number of digits for total (SETUP 1.2)!</i></p>
1.5	FACTOR-X		<p>This setting determines the multiplication factor of the Total and Accumulated Total. This makes it possible to show up to 3 digits more of the Total/accumulated Total. The amount shown is a rounded number. The following can be selected:            x1 – x10 – x100 – x1000</p>
1.6	CLEAR PASSWORD		<p>Clearing Total by the Operator can be password protected. This protection is disabled with value 000 (zero).            Up to and including 3 digits can be programmed, for example 123.</p>

## 3.2.5 EXPLANATION OF SETUP MENU 2 - FLOWRATE





These settings also influence the analog output.

2 FLOWRATE		
2.1	UNIT	 Note ! First set the flowmeter unit at SETUP 4.2. It has a direct influence on this flowrate unit setting. Change of the type of flowmeter unit (volumetric or mass) will cause the setting of the flowrate unit (SETUP 4.3) to automatically change to the default unit of that type.  SETUP 2.1 determines the measurement unit for flowrate. The flowrate unit that can be chosen depends on the type of flowmeter unit (volumetric or mass) set at SETUP 4.2. The following can be selected: Volumetric: mL – L – m3 – US GAL – I GAL – Oil bbl – cf – scf – NM3 – NL. Mass: mg – g – kg – ton – US ton – lb. Hand: L – m3 – mg – g – kg -   Note ! Units which cannot be converted are only accessible with selection Hand (SETUP 4.2). In this case the Flowrate K-factor and its decimals need to be set at SETUP 2.4 and SETUP 2.5.
2.2	TIME	 Note ! The flowrate can be calculated per /sec - /min - /hour - /day. Changes to SETUP 2.2 Time unit has an effect on the analog output settings of SETUP 6.2 Rate Min and SETUP 6.3 Rate Max and SETUP 3.5 Ratespan. Don't forget to update these settings after a change!
2.3	DECIMALS	 Note ! This setting determines for flowrate the number of decimals. The following can be selected: 0, 0.1, 0.02, 0.003  Changes to SETUP 2.3 Decimals will also change the decimal setting of SETUP 6.2 Rate Min and SETUP 6.3 Rate Max and SETUP 3.5 Ratespan. Therefore it is best practice to first determine the required decimals for the flowrate!
 Caution ! <b>The next two menu items can be modified only if the automatic unit conversion in SETUP 4.2, Flowmeter-units, is set to Hand. Else, the display will show "AUTO".</b>		
2.4	K-FACTOR	 Note ! With the Flowrate K-factor, the flowmeter pulse signals are converted to a flowrate unit. The Flowrate K-factor is based on the number of pulses generated by the flowmeter per selected measurement unit (SETUP 2.1). The more accurate the K-factor, the more accurate the functioning of the system will be.  Alteration of the K-Factor will have consequences for Operator and SETUP-level values!
2.5	K-FACTOR DECIMALS	 Note ! This setting determines the number of decimals for the K-factor entered. The following can be selected: 0 – 1 – 2 – 3 – 4 – 5 – 6  <ul style="list-style-type: none"> <li>• This setting influences the accuracy of the K-factor indirectly (i.e. the position of the decimal point and thus the value given).</li> <li>• This setting has NO influence on the displayed number of digits for total (SETUP 2.3)!</li> </ul>

2.6	CALCULATION	<p>The flowrate is calculated by measuring the time between a number of pulses, for example 10 pulses. The more pulses the more accurate the flowrate will be. The maximum value is 255 pulses.</p> <p> Note ! <i>This setting does influence the update time for the analog output directly (maximum update 10 times a second). If the output response is too slow, decrease the number of pulses.</i></p> <p> Note ! <i>The lower the number of pulses, the higher the power consumption of the unit will be (important for battery powered applications).</i></p> <p> Note ! <i>For low frequency applications (below 10Hz): do not program more than 10 pulses else the update time will be very slow.</i></p> <p><i>For high frequency application (above 1kHz) program a value of 50 or more pulses</i></p>
2.7	CUT-OFF	<p>With this setting, a minimum flow requirement threshold is determined, if during this time less than XXX-pulses (SETUP 2.6) are generated, the flowrate will be displayed as zero.</p> <p>The cut-off time has to be entered in seconds – maximum time is 999.9 seconds (approximately 15 minutes).</p>

### 3.2.6 EXPLANATION OF SETUP MENU 3 - DISPLAY

<b>3</b>	<b>DISPLAY</b>	
3.1	FUNCTION	<p>The function can be set to display <b>total</b>, <b>flowrate</b> or accumulated total</p> <ul style="list-style-type: none"> <li>• When "total" is selected, total is displayed with the large 12mm (0.47") digits and flowrate is displayed with the 7 mm (0.28") digits simultaneously.</li> <li>• When "flowrate" is selected, only flowrate will be displayed with the large 12mm (0.47") digits together with its measuring unit while total will be displayed after pressing SELECT.</li> <li>• When "accumulated total" is selected, total is displayed with the large digits and accumulated total is displayed with the small digits simultaneously.</li> </ul>
		<p> Note ! <i>When battery powered, the user can expect reliable measurement over a long period of time. The E112-P has several smart power management functions to extend the (optional) battery life time significantly next to permanently disabling the optical keys. The following functions can be set:</i></p>
3.2	LCD NEW	<p>The calculation of the display-information influences the power consumption significantly. When the application does not require a fast display refresh rate, it is strongly advised to select a slow refresh rate. Please understand that NO information will be lost; every pulse will be counted and the output signals will be generated in the normal way.</p> <p>The following can be selected: fast – 1 sec – 3 sec – 15 sec – 30 sec – off</p> <p>When "off" is selected the display will be automatically switched off after 30 seconds since the last action. The display will return again after touching one of the keys</p>
3.3	BACKLIGHT	<p>The unit is provided with a backlight. The backlight brightness can be adjusted from off (0) to a 100% in steps of 20%.</p> <p>The following can be selected: 0% - 20% - 40% - 60% - 80% - 100%</p> <p>For battery powered units the brightness is not adjustable</p> <p> Note ! <i>When the unit is only loop powered it cannot make use of the backlight. In that case an external supply is required</i></p>

3.4	BARGRAPH	The unit has a speedometer display which offers a quick impression of the actual flow rate. This graph on the display can be switched on or off. The following can be selected: enable / disable
3.5	RATESPAN	With Ratespan the range of the speedometer can be set. The display shows 0 – 100 with 20 blocks so each block is 5% of the 100% range set here. The following can be selected: 0000000 – 9999999   Note ! <i>The number of decimals displayed depends upon SETUP 2.3.</i>



### 3.2.7 EXPLANATION OF SETUP MENU 4 - FLOWMETER



Note !

The selections “Active pulse input” offer a pulse detection level of 50% of the supply voltage

4 FLOWMETER				
4.1	SIGNAL	The E112-P is able to handle several types of input signal. The type of flowmeter pickup / signal is selected with SETUP 4.1. Read also chapter. 4.5.		
	TYPE OF SIGNAL	EXPLANATION	RESISTANCE	FREQ. / mVpp
	NPN	NPN input	100 k $\Omega$ pull-up	max. 6 kHz. (open collector)
	NPN - LP	NPN input with low pass filter	100 k $\Omega$ pull-up	max. 2.2 kHz. (open collector) less sensitive
	REED	Reed-switch input	1 M $\Omega$ pull-up	max. 1.2k Hz.
	REED - LP	Reed-switch input with low pass filter	1 M $\Omega$ pull-up	max. 120 Hz. Less sensitive
	PNP	PNP input	51 k $\Omega$ pull-down	max. 6 kHz.
	PNP - LP	PNP input with low pass filter	51 k $\Omega$ pull-down	max. 700 Hz. Less sensitive
	NAMUR	NAMUR input	820 $\Omega$ pull-down	max. 4 kHz. External power required
	COIL HI	High sensitive coil input	-	min. 20 mVpp.
	COIL HI (option ZF)			min. 10 mVpp.
	COIL HI (option ZG)			min. 5 mVpp.
	COIL LO	Low sensitive coil input	-	min. 90 mVpp Normal sensitivity
	ACT_8.1	Active pulse input detection level 3.9 Vdc	3k9 $\Omega$ pull-down	max. 10 kHz. External power required
	ACT_24	Active pulse input detection level 11 Vdc	3 k $\Omega$ pull-down	max. 10 kHz. External power required

4.2	UNITS	<p>With this setting the automatic unit conversion is enabled for volumetric flows or mass flows. When Hand is selected, the automatic unit conversion is disabled.</p> <p>The following can be selected: AUTO-VOL, AUTO-MASS, HAND</p>
		<p><b>To make use of the automatic unit conversion, Total and Flowrate unit must have a convertible unit. If this is not possible, HAND should be chosen. This will cause SETUP 4.3 to SETUP 4.5 to disappear and the unit, K-factor and K-factor decimals must be specifically set at SETUP 1 – Total and SETUP 2 – Flowrate.</b></p>
4.3	K-FACTOR UNIT  	<p>SETUP 4.3 determines the measurement unit for the flowmeter. With automatic unit conversion, the units for Total and Flowrate are derived from this setting. The following can be selected: L – m<sup>3</sup> – US GAL – IGAL – cf – oil bbl – kg – ton – US ton – lb</p> <ul style="list-style-type: none"> <li>• Change of the type of flowmeter unit (volumetric or mass) will cause the setting of the Total (SETUP 1.1) and Flowrate (SETUP 2.1) to automatically change to the default unit of that type.</li> <li>• Change of the flowmeter unit will not change the amount displayed for Total and accumulated Total.</li> </ul>
4.4	K-FACTOR	<p>With the K-factor, the flowmeter pulse signals are converted to a quantity. The K-factor is based on the number of pulses generated by the flowmeter per selected measurement unit (SETUP 4.3), for example per cubic meter. The more accurate the K-factor, the more accurate the functioning of the system will be.</p> <p><b>Example 1: Calculating the K-factor.</b> Assume that the flowmeter generates 2.4813 pulses per liter and the selected unit is “cubic meters / m<sup>3</sup>”. A cubic meter consists of 1000 parts of one liter which implies 2,481.3 pulses per m<sup>3</sup>. So, the K-factor is 2,481.3. Enter for SETUP 4.4: “2481300” and for SETUP 4.5 – decimals K-factor “3”.</p> <p><b>Example 2: Calculating the K-factor.</b> Assume that the flowmeter generates 6.5231 pulses per gallon and the selected measurement unit is gallons. So, the K-Factor is 6.5231. Enter for SETUP 4.4: “6523100” and for SETUP 4.5 decimals K-factor “6”.</p>
4.5	K-FACTOR DECIMALS  	<p>This setting determines the number of decimals for the K-factor entered (SETUP 4.4).</p> <p>The following can be selected: 0 – 1 – 2 – 3 – 4 – 5 – 6</p> <p><i>This setting influences the accuracy of the K-factor indirectly (i.e. the position of the decimal point and thus the value given).</i></p>

### 3.2.8 EXPLANATION OF SETUP-MENU 5 – LINEARIZE

The linearization function is available to approach the real flow curve better as with the general K-factor (KF0). This to obtain a more accurate flowrate, total and accumulated total as well as the analog and pulse output at any flowmeter frequency.

A maximum of 15 linearization-positions can be entered while the interpolation will calculate any other position in-between.

For each linearization position, the frequency and a Meter Factor (MF) must be entered.

The Meter Factor for each frequency is calculated with following formula:

$$\text{Meter Factor} = \frac{\text{K-Factor @ flow rate X}}{\text{KF0}}$$



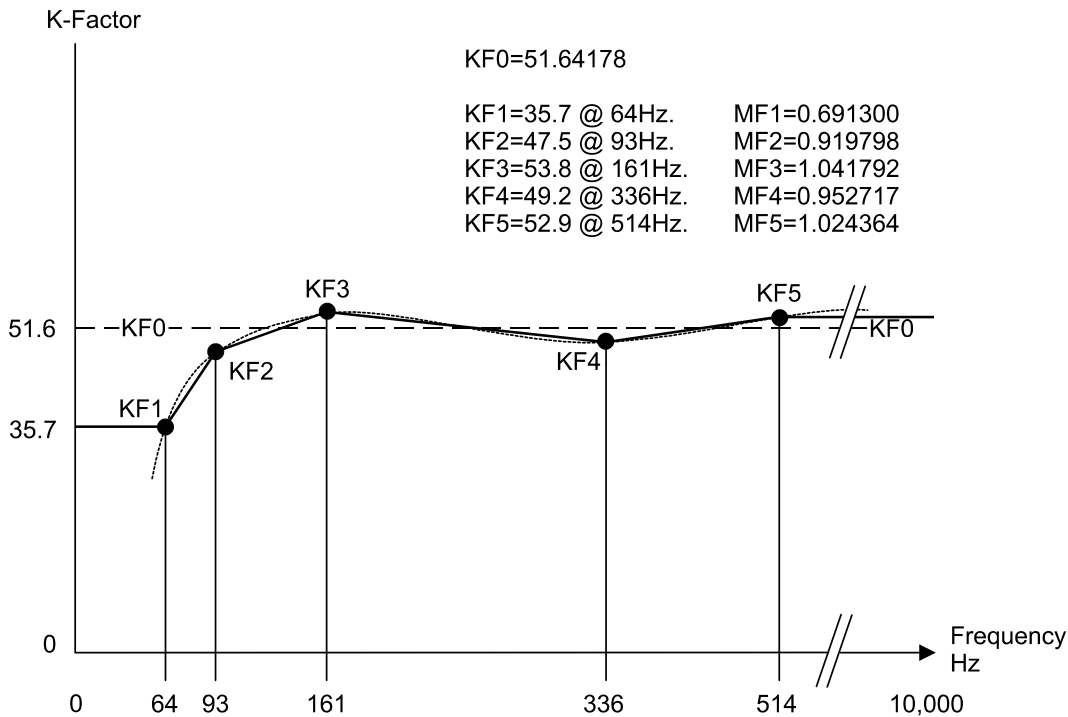

The lowest frequency and MF you enter will be valid from 0Hz. The highest frequency and MF will be valid till 10KHz. It is advised to enter the frequencies in increasing order, however it is not necessary. Please have a look at following example to understand the method of linearization:



5. LINEARIZATION		
5.1 ↕ 5.F	FREQ. / M-FACTOR 1 ↕ FREQ. / M-FACTOR 15	The frequency is displayed at the bottom line of the display. The maximum frequency is 9,999.9 Hz. With value 0.0Hz, the M-Factor is disabled. (Please read SETUP 5.H – decimals frequency) The M-Factor is displayed at the top-line of the display. The minimum value to be entered is 0.000001 and the maximum value is 9.999999. Most M-factors will be around 1.000000 like 0.945354 or 1.132573.  <i>This value has always six decimals while the "dot" is not displayed.</i>
5.G	LINEARIZATION	With this setup function, you can easily enable / disable the linearization function.
5.H	DECIMALS FREQUENCY	This setting determines the number of decimals for the frequency entered. The following can be selected: 0 – 0.1 – 0.02 – 0.003

### 3.2.9 EXPLANATION OF SETUP MENU 6 - ANALOG OUTPUT

An analog 4-20mA signal is generated according to the differential flowrate with a 12 bits resolution. The settings for flowrate (SETUP 2) influence the analog output directly. The relationship between rate and analog output is set with the following functions.

6 ANALOG OUTPUT					
6.1	OUTPUT	The analog output can be disabled. In case of a passive analog output 3.5mA will be generated if a power supply is available but the output is disabled. The following can be selected: enable – disable			
6.2	RATE-MIN (4mA)	Enter here the flowrate-at which the output should generate the minimum signal (4mA) – in most applications at flowrate “0”. The number of decimals displayed depend upon SETUP 2.3. The time and measuring units (L/min for example) are dependent upon SETUP 2.1 and SETUP 2.2 and are displayed during editing. <i>If desired, you can program the analog output 'up-side-down'. The 4mA represents the maximum flow rate. For example do enter 800L/min.</i>			
			Note !		
6.3	RATE-MAX (20mA)	Enter here the flowrate-at which the output should generate the maximum signal (20mA) – in most applications at maximum flow. The number of decimals displayed depend upon SETUP 2.3. The time and measuring units (L/min for example) are dependent upon SETUP 2.1 and SETUP 2.2 and are displayed during editing. <i>If desired, you can program the analog output 'up-side-down'. The 20mA represents the minimum flow rate. For example do enter 0L/min.</i>			
			Note !		
6.4	CUT-OFF	To ignore leakage of the flow for example, a low flow cut-off can be set as a percentage of the full range of 16mA, (or 20mA). When the flow is less than the required rate, the current will be the minimum signal (4mA). Example:			
		<b>4mA SETUP 6.2</b>	<b>20mA SETUP 6.3</b>	<b>CUT-OFF SETUP 6.4</b>	<b>REQUIRED RATE</b>
		0 L/min	100 L/min	2%	$(100-0)*2\% = 2.0 \text{ L/min}$
		20 L/min	800 L/min	3.5%	$(800-20)*3.5\% = 27.3 \text{ L/min}$
		<b>OUTPUT</b>			
					$4+(16*2\%) = 4.32\text{mA}$
					$4+(16*3.5\%)=4.56\text{mA}$
6.5	TUNE MIN (4mA)	The initial minimum analog output value is 4mA. However, this value might differ slightly due to ambient influences such as temperature for example. The 4mA value can be tuned precisely with this setting. <b>Before tuning the signal, be sure that the analog signal is not being used for any application!</b> After pressing PROG, the current will be about 4mA. The current can be increased / decreased with the arrow-keys and is directly active. Press ENTER to store the new value. <i>Note: while powering-up the loop, the initial current is approx. 2mA This can take a few seconds.</i>			
			WARNING		
			Note !		
6.6	TUNE MAX (20mA)	The initial maximum analog output value is 20mA. However, this value might differ slightly due to ambient influences such as temperature for example. The 20mA value can be tuned precisely with this setting. <b>Before tuning the signal, be sure that the analog signal is not being used for any application!</b> After pressing PROG, the current will be about 20mA. The current can be increased / decreased with the arrow-keys and is directly active. Press ENTER to store the new value.			
			WARNING		

6.7	FILTER	This function is used to stabilize the analog output signal. The output value is updated every 0.1 second. With the help of this digital filter a more stable but less precise reading can be obtained. The filter principal is based on three input values: the filter level (01-99), the last analog output value and the last average value. The higher the filter level, the longer the response time on a value change will be
-----	--------	-------------------------------------------------------------------------------------------------------------------------------------------------------------------------------------------------------------------------------------------------------------------------------------------------------------------------------------------------------------------------------------------------------------------------------------

### 3.2.10 EXPLANATION OF SETUP MENU 7 – PULSE

One transistor or relay output is available as scaled pulse output according to the accumulated total.

7 PULSE		
7.1	WIDTH	<p>The pulse width determines the time that the output will be active; in other words the pulse duration. The pulse width is set in milliseconds in the range 0.001 – 9.999 sec. Value “zero” will disable the pulse output.</p> <p> Note ! <i>The pulse signal always has a 50% duty cycle, hence the minimum time between the pulses is equal to the pulse width setting. If the frequency should go out of range – when the flowrate increases for example – an internal buffer will be used to “store the missed pulses”: As soon as the flowrate slows down, the buffer will be “emptied”. It might be that pulses will be missed due to a buffer-overflow, so it is advised to program this setting within its range!</i></p>
7.2	DECIMALS	This setting determines the number of decimals. The following can be selected: 0, 0.1, 0.02, 0.003
7.3	AMOUNT	One pulse is generated every X-quantity measured. If for example you want 100 pulses per gallon: do enter 0.01 GAL (this means one pulse every 0.01 GAL, so 100 pulses per gallon). Enter this quantity here while taking the decimal position of SETUP 7.2 into account. The following can be selected: 000.000 – 9999999

### 3.2.11 EXPLANATION OF SETUP MENU 8 - COMMUNICATION (OPTION)

7 COM-MODB		
8.1	SPEED	For external control, the following communication speeds can be selected: 1200 – 2400 – 4800 – 9600 – 9600HP – 19200 – 38400
8.2	ADDRESS	For communication purposes, a unique identity can be attributed to every E112-P. This address can vary from 001-247.
8.3	MODE	The communication protocol is Modbus ASCII or RTU mode. Select OFF, to disable this communication function.
8.4	DATABITS	This setting determines for communication the number of databits. Select 8 bit for bus-rtu and 7 or 8 bits for bus-asc.
8.5	PARITY	As demanded by the connected equipment, select a parity bit (odd, even or none).

**3.2.12 EXPLANATION OF SETUP MENU 9 - DATALOGGING (OPTION)**

<b>9</b>	<b>DATALOG</b>	
	 Note !	<i>For detailed information, refer to the manual E-series – Datalogging.</i>

**3.2.13 EXPLANATION OF SETUP MENU 9 OR 10 - OTHERS****For E112-P without datalogging**

<b>9</b>	<b>OTHERS</b>	
9.1	MODEL	For support and maintenance it is important to have information about the characteristics of the E112-P. Your supplier will ask for this information in the case of a serious breakdown or to assess the suitability of your model for upgrade considerations.
9.2	SOFTWARE VERSION	For support and maintenance it is important to have information about the characteristics of the E112-P. Your supplier will ask for this information in the case of a serious breakdown or to assess the suitability of your model for upgrade considerations.
9.3	SERIAL NO.	For support and maintenance it is important to have information about the characteristics of the E112-P. Your supplier will ask for this information in the case of a serious breakdown or to assess the suitability of your model for upgrade considerations.
9.4	PASSWORD	All SETUP values can be password protected. This protection is disabled with value 0000 (zero). Up to and including 4 digits can be programmed, for example 1234.
9.5	KEY LOCK	To avoid undesired use of the optical keyboard it can be locked automatically after 30 seconds by enabling this function.
9.6	TAG-NO	For identification of the unit and communication purposes, a unique tag number of maximum 7 digits can be entered.

**For E112-P with datalogging**

<b>10</b>	<b>OTHERS</b>	
10.1	MODEL	For support and maintenance it is important to have information about the characteristics of the E112-P. Your supplier will ask for this information in the case of a serious breakdown or to assess the suitability of your model for upgrade considerations.
10.2	SOFTWARE VERSION	For support and maintenance it is important to have information about the characteristics of the E112-P. Your supplier will ask for this information in the case of a serious breakdown or to assess the suitability of your model for upgrade considerations.
10.3	SERIAL NO.	For support and maintenance it is important to have information about the characteristics of the E112-P. Your supplier will ask for this information in the case of a serious breakdown or to assess the suitability of your model for upgrade considerations.
10.4	PASSWORD	All SETUP values can be password protected. This protection is disabled with value 0000 (zero). Up to and including 4 digits can be programmed, for example 1234.
10.5	KEY LOCK	To avoid undesired use of the optical keyboard it can be locked automatically after 30 seconds by enabling this function.
10.6	TAG-NO	For identification of the unit and communication purposes, a unique tag number of maximum 7 digits can be entered.

## 4 INSTALLATION

### 4.1 GENERAL DIRECTIONS



Caution !

- Mounting, electrical installation, start-up and maintenance of this instrument may only be carried out by trained personnel authorized by the operator of the facility. Personnel must read and understand this Operating Manual before carrying out its instructions.
- The E112-P may only be operated by personnel who are authorized and trained by the operator of the facility. All instructions in this manual are to be observed.
- Ensure that the measuring system is correctly wired up according to the wiring diagrams. Protection against accidental contact is no longer assured when the housing cover is removed or the panel cabinet has been opened (danger from electrical shock). The housing may only be opened by trained personnel.
- Take careful notice of the “Safety rules, instructions and precautionary measures” at the front of this manual.

### 4.2 INSTALLATION / SURROUNDING CONDITIONS

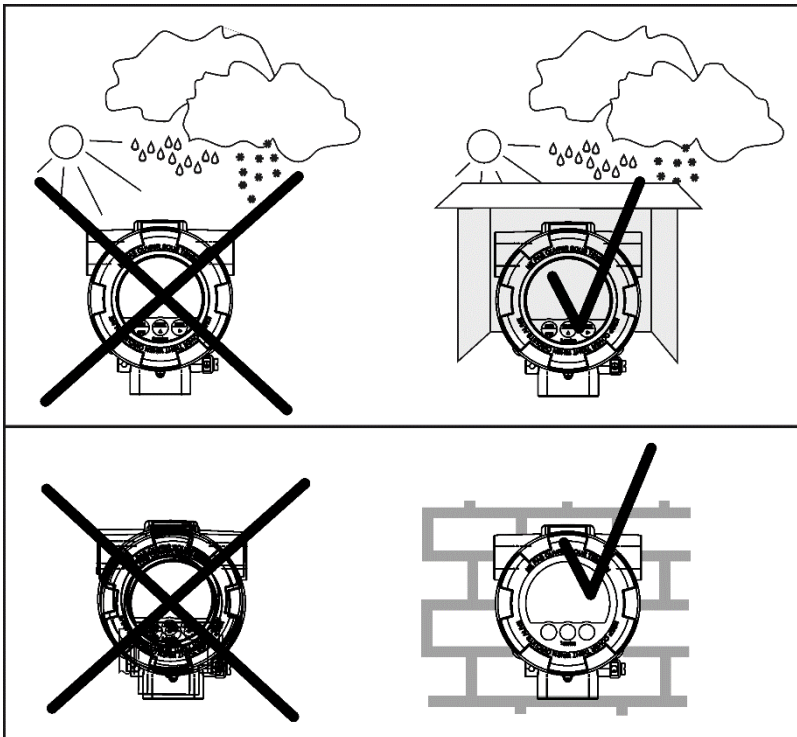

Take the relevant IP classification of the casing into account (see manufactures plate). Even an IP66 / IP67 / TYPE 4X casing should NEVER be exposed to strongly varying (weather) conditions.

When used in very cold surroundings or varying climatic conditions, take the necessary precautions against moisture by placing a dry sachet of silica gel, for example, inside the instrument case.

Mount the E112-P on a solid structure to avoid vibrations

Relative humidity:	< 90% RH
Outdoor use:	suitable for outdoor use
IP and NEMA rating:	IP66, IP67 and NEMA Type 4X
Supply voltage fluctuation:	+/- 10% unless stated otherwise
Means of protection:	Class I
Over-voltage category:	II
Pollution degree:	2 (internal environment), 3 (external environment)
Ambient:	-40 °C to +70 °C, -40 °F to + 158 °F
Altitude:	up to 2000 m

4.3 DIMENSIONS – ENCLOSURE

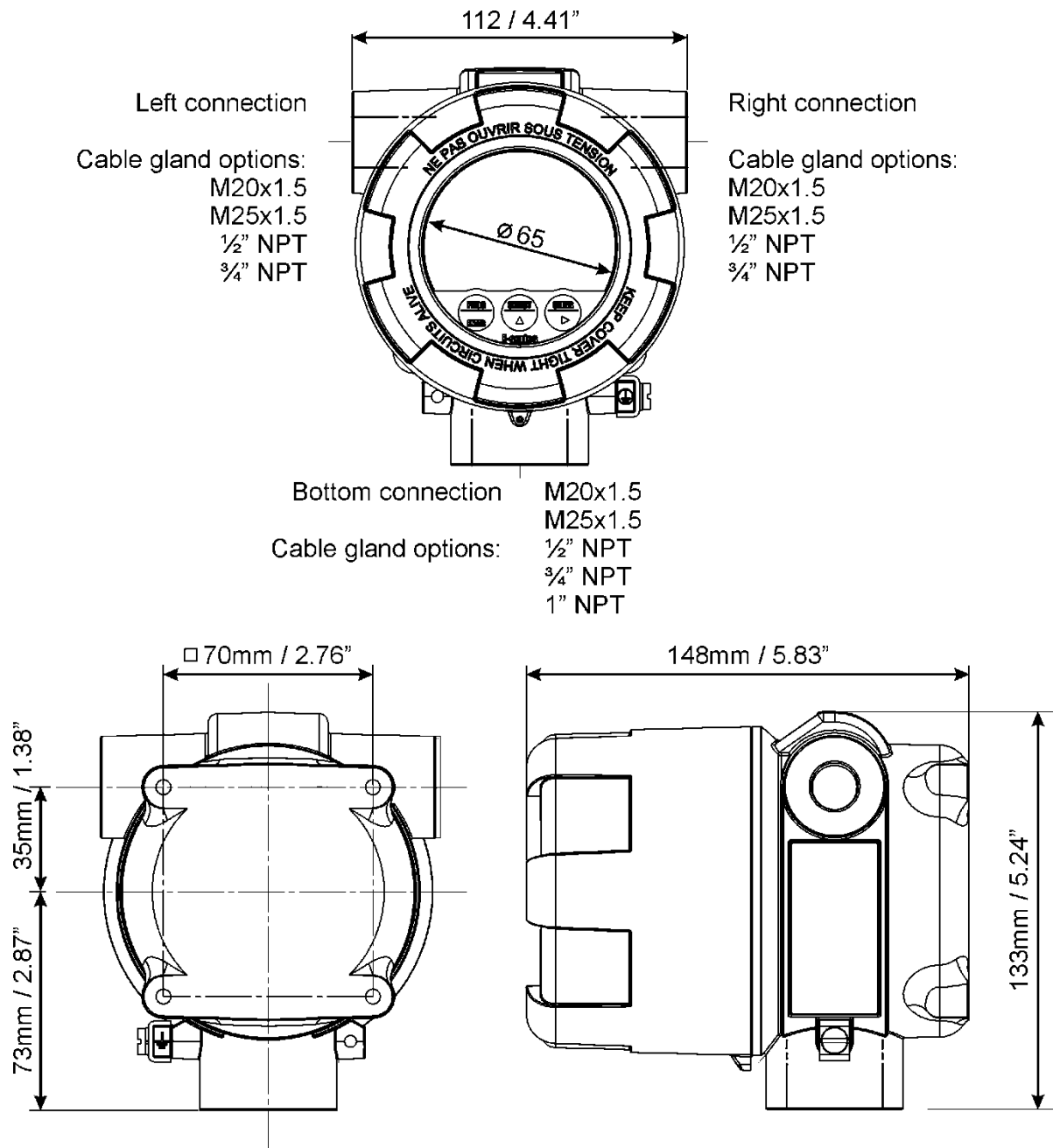

Fig. 8: Dimensions – Aluminum / Stainless Steel enclosures.

## 4.4 INSTALLING THE HARDWARE

### 4.4.1 INTRODUCTION



- Electro static discharge does inflict irreparable damage to electronics! Before installing or opening the E112-P, the installer has to discharge himself by touching a well-grounded object.
- The E112-P must be installed in accordance with the EMC guidelines (Electro Magnetic Compatibility).



- When installed in a potentially explosive atmosphere that requires apparatus of equipment protection level Gb and Db, the unit must be installed such that, even in the event of rare incidents, an ignition source due to impact or friction sparks between the enclosure and aluminum/steel is excluded.
- Do ground the aluminum / stainless steel enclosure properly with a PE wire as indicated to the Protective Earth terminal.
- The installation must comply with national requirements (e.g. in Canada, the Canadian Electrical Code, C22.1, Part 1 and in USA, the National Electrical Code, NFPA 70 and ANSI/ISA-RP 12).



Note !

*The display inside the enclosure can be installed in four positions: 0°; 90°; 180°; 270°, so the enclosure can be installed in four positions.*

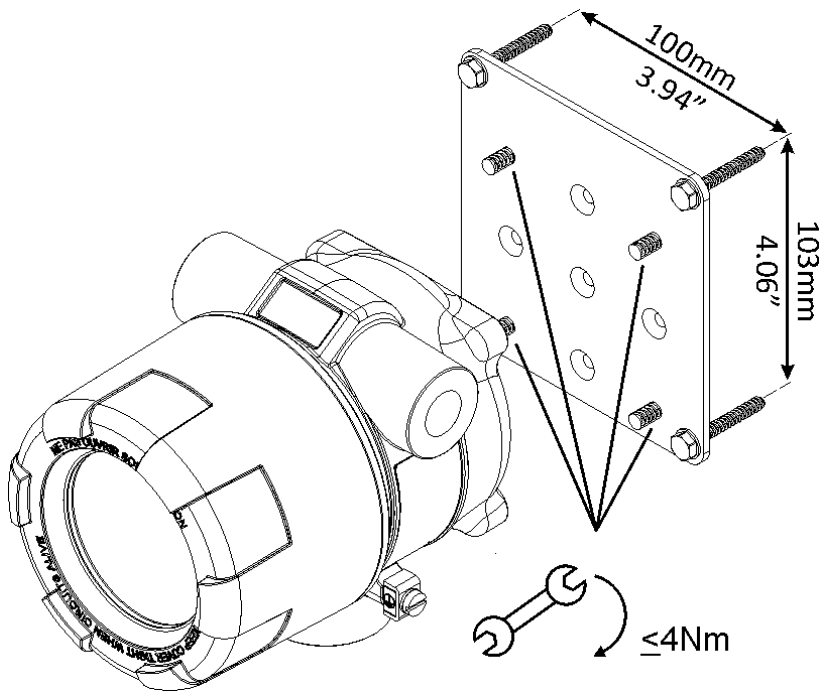
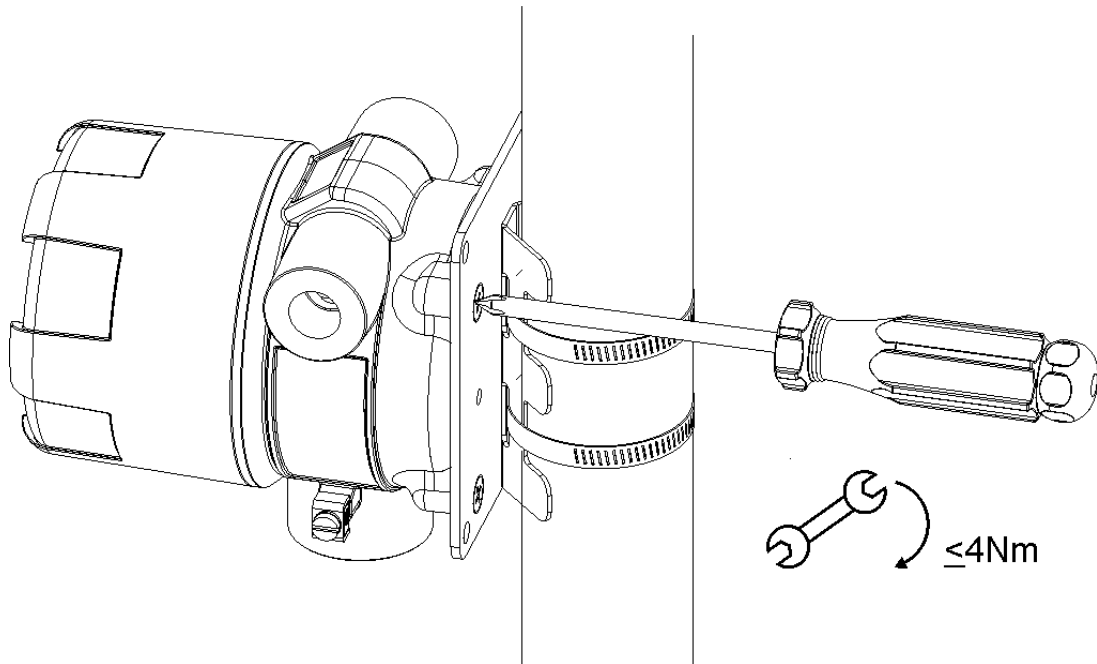
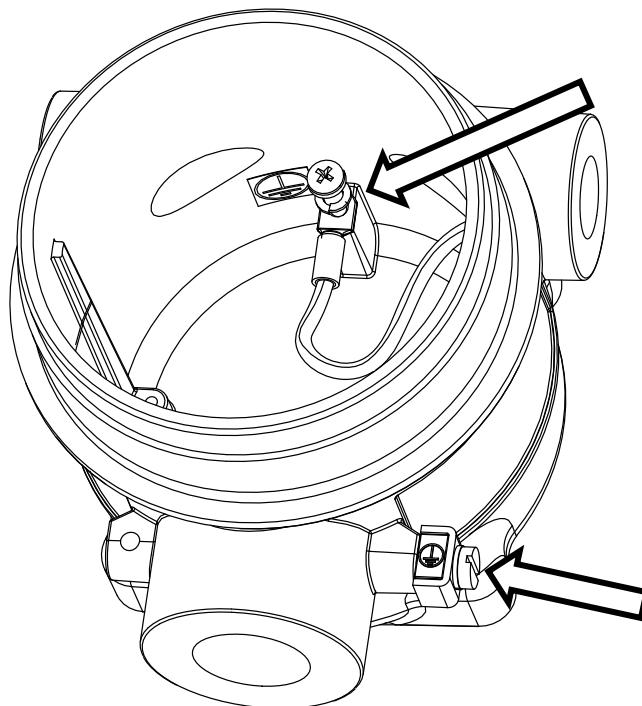

Fig. 9: Installation – Plate mounted

**Pipe mount with bracket and hose clamps****Fig. 10: Installation – Pipe mounted**

For Class 1 applications make sure to apply proper internal (as well as external) grounding to PE terminal as shown.

PE terminal: Stranded conductor: 4 mm<sup>2</sup>, Single conductor: 6 mm<sup>2</sup>

**Fig. 11: Grounding enclosure**

**Installation instructions – Electrical**

**For battery supplied equipment:  
DO NOT OPEN WHEN AN EXPLOSIVE GAS ATMOSPHERE IS PRESENT.**

- Use Ex-d cable glands with effective IP67 (TYPE4X) seals for the cables used;
- For unused cable entries fit IP67 (TYPE4X) blind plugs;
- Make a reliable ground connection to the metal enclosure.;
- Use only an effective screened cable for the input signal, and grounding of its screen to terminal S1 (GND) AND to the enclosure or at the sensor itself, whichever is appropriate to the application. Be careful not to create ground loops!.
- Without thermal separator, the process temperature shall not exceed the specified maximum ambient temperature;
- When the enclosure temperature exceeds 70 °C / 158 °F, apply suitable cable and gland for this temperature;
- The cable entry plugs mounted into the enclosure shall comply with the requirements of the type of protection used.

The E-series can be connected to another Ex-d enclosure following the compulsory conditions below:

- The part which is used for the connection between the two volumes must be Ex-d certified;
- The connected enclosure must be Ex-d certified with its own electrical equipment inside (i.e. pickup coil or other sensors);
- For the short cylinder version, the volume of empty space inside this added volume must not represent more than 13,5 cm<sup>3</sup>;
- There may be no generation of heat in the added enclosure;
- There may be no added electrical energy in the added enclosure; any energy which comes from the E-series is already taken into account in the E-series certificate.

**4.4.2 SEAL CONDUITS/ENCLOSURE**

- For FM Group A,B,C,D : “SEAL ALL CONDUIT ENTRIES WITHIN 18 INCHES”.
- For CSA group B,C,D: “SEAL ALL CONDUIT ENTRIES WITHIN 18 INCHES”.
- For CSA group A: “FOR GROUP A SEAL AT ENCLOSURE WALL”

**4.4.3 SPECIAL CONDITIONS FOR SAFE USE**

- The painted aluminum enclosure shall be installed in such a way that danger of ignition due to electrostatic discharge is avoided. Possible electrostatic hazard – clean only with a moist cloth. Use only in fixed installations and do not place in areas with rapid airflow.

**4.4.4 FLAMEPROOF JOINTS**

- Clause 5: EN/IEC 60079-1:2007 (Use certified / Ex-d cable glands).
- All flameproof joints are designed for:
  - Volume  $500 < V \leq 2000 \text{ cm}^3$ ;
  - Group IIC enclosures.

There are 4 types of joints between inner and outside of the E-type enclosure which are flameproof:

1. The cement between glass and cover (length  $\geq 10\text{mm}$ )
2. Thread between body/cover M100x1.5 (Tolerance 6g/6H min. 8 full threads engaged)
3. Thread for conduit opening left and right:
  - M20 x 1.5, M25 x 1.5, (for metric: Tolerance 6g/6H min. 8 full threads engaged);
  - ½ NPT, ¾ NPT. (for NPT: Tolerance ANSI/ASME B1.20.1).
4. The process opening:
  - M20 x 1.5, M25 x 1.5 (for metric: Tolerance 6g/6H min. 8 full threads engaged);
  - ½ NPT, ¾ NPT, 1 NPT (for NPT: Tolerance ANSI/ASME B1.20.1);
  - All NPT threads (cable entry openings) are in accordance with ANSI/ASME B1.20.1.
  - All Metric threads (cable entry openings, thread between body and cover and threaded holes for feed thru capacitors) are in accordance with fit class 6g/6H (ISO 965-1 + 965-3).

When installed according to this manual, this product will meet the directives and standards as listed in Appendix A of this manual.

#### 4.4.5 ELECTRICAL SAFETY

The following environmental conditions and safety parameters apply when installing the E112-P.

Relative humidity	< 90% RH
Outdoor use	suitable for outdoor use
IP and TYPE rating	IP66, IP67 and TYPE4X / TYPE 7 / TYPE9.
Supply voltage fluctuation	± 10% unless stated otherwise
Means of protection	Class I
Over-voltage category	II
Pollution degree	2 (internal environment), 3 (external environment)
Ambient temperature	-40 °C to +70 °C, (-40 °F to +158 °F)
Altitude	up to 2000m

The following supply ratings apply for the various installed options within the E-series product. This allows for suitable selection of the power supply and overcurrent protection.”

(not mentioned options implies no or neglectable influence on the ratings)

Installed option	Input	Supply Voltage range	Maximum supply current	Remark
PD	P6	24-27Vdc	110 mA	With 2xOR option
PD	P2	9-27Vdc	75 mA	Without OR option
PX	P2	9-27Vdc	50 mA	Without OR option
PB	Battery connector	Typical 3.6V. Only use Fluidwell replacements	10 mA	Without OR option
AH	A1/A2	11-27Vdc	25 mA	AH only not suitable for OR

If a combination of inputs is used, use the maximum value mentioned!

The output relay (OR option) is of type SPST and has the following contact ratings:

Load type & Voltage	Current
Maximum resistive load at 30 Vdc, 125 Vac or 250 Vac.	Max. 2 A
Maximum inductive load (for pilot duty applications) at 30 Vdc, 125 Vac or 250 Vac.	Max. 0.5 A

- All wiring must be in accordance with local codes and regulations.
- In case this instrument is connected to a supply by means of a permanent connection a switch or circuit-breaker shall be included in the installation. This shall be in close proximity to the equipment and within easy reach of the operator. It shall be marked as the disconnecting device for the equipment.
- Except for the relay outputs R7 to R10 all connections to the unit shall be low voltage defined as “SELV” circuit per IEC 60950-1.
- The equipment shall be supplied from a “SELV” circuit defined as per IEC 60950-1.
- A suitable power supply should be considered in end-use equipment. The power supply must be in compliance with a limited-energy circuit (maximum available current of 8 A). If the power supply cannot be in compliance with a limited-energy circuit:
- For safety install an overcurrent protection device (such as fuse) with adequate breaking capacity close to the instrument.
  - Fuse type: Time-lag fuse (Approved fuse according to IEC60127-2 and/or UL248-14)
  - Fuse rating: Rated current: 5 A
- The installation must comply with national requirements (e.g. in Canada, the Canadian Electrical Code, C22.1, Part 1 and in USA, the National Electrical Code, NFPA 70, Article 500-series and ANSI/ISA-RP 12).

#### 4.4.6 VOLTAGE SELECTION SENSOR SUPPLY

##### Type PB / PX – Pickup element supply

Terminal S3 provides a limited supply voltage of 3.2 V DC (coil signals 1.2V) for the signal output of the flowmeter. Output impedance is 2700 ohms, power is limited to 3.3 mW under short circuit conditions.



Note !

*This voltage MAY NOT be used to power the flowmeters electronics, converters etc, as it will not provide adequate sustained power ! All energy used by the flowmeters pick-up will directly influence the battery life-time (type PB). It is strongly advised to use a “zero power” pickup such as a coil or reed-switch when operating without external power. It is possible to use some low power NPN or PNP output signals, but the battery life time will be significantly reduced (consult your distributor).*

##### Type PD: Sensor supply: 8.2V – 12V or 24 V (Vin P2 minus 1V) DC

With this option, a supply derived from the input supply becomes available. The output voltage of P3 can be adjusted by means of switches J1 and J2 on the back of the PCB (see figure 12) See the label or **Appendix A**, section “**Sensor excitation**”, for the exact ratings of terminal P3.



Note !

- 8.2V DC supply requires an input voltage of 9-27V and 12V DC supply requires an input voltage of 13-27V
- The output is protected against overload. In case of an overload also the functionality of the E112-P is affected!

The voltage is selected with the two switches at the rear of the Main Electronics Module (MEM). The switches are located at the bottom center (type PD):

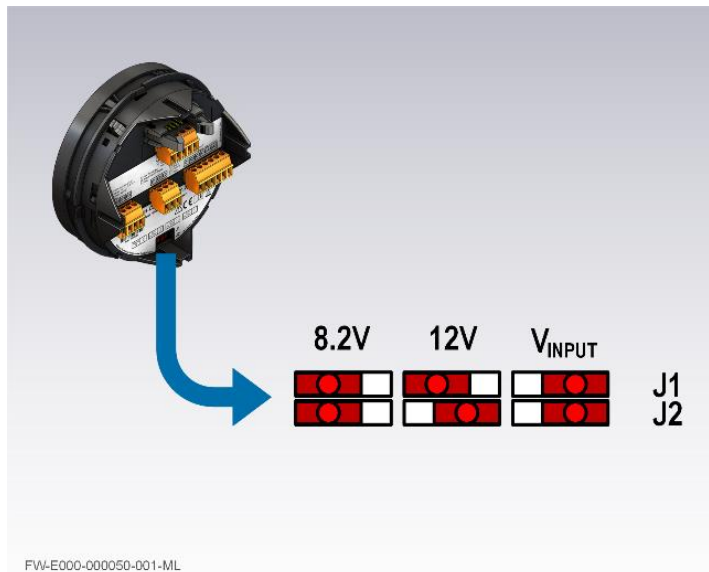

Fig. 12: Voltage selection – Sensor supply (P3).

### 4.5 TERMINAL CONNECTORS – MAIN ELECTRONICS MODULE

The following terminal connectors are available for the Main Electronics Module (MEM):

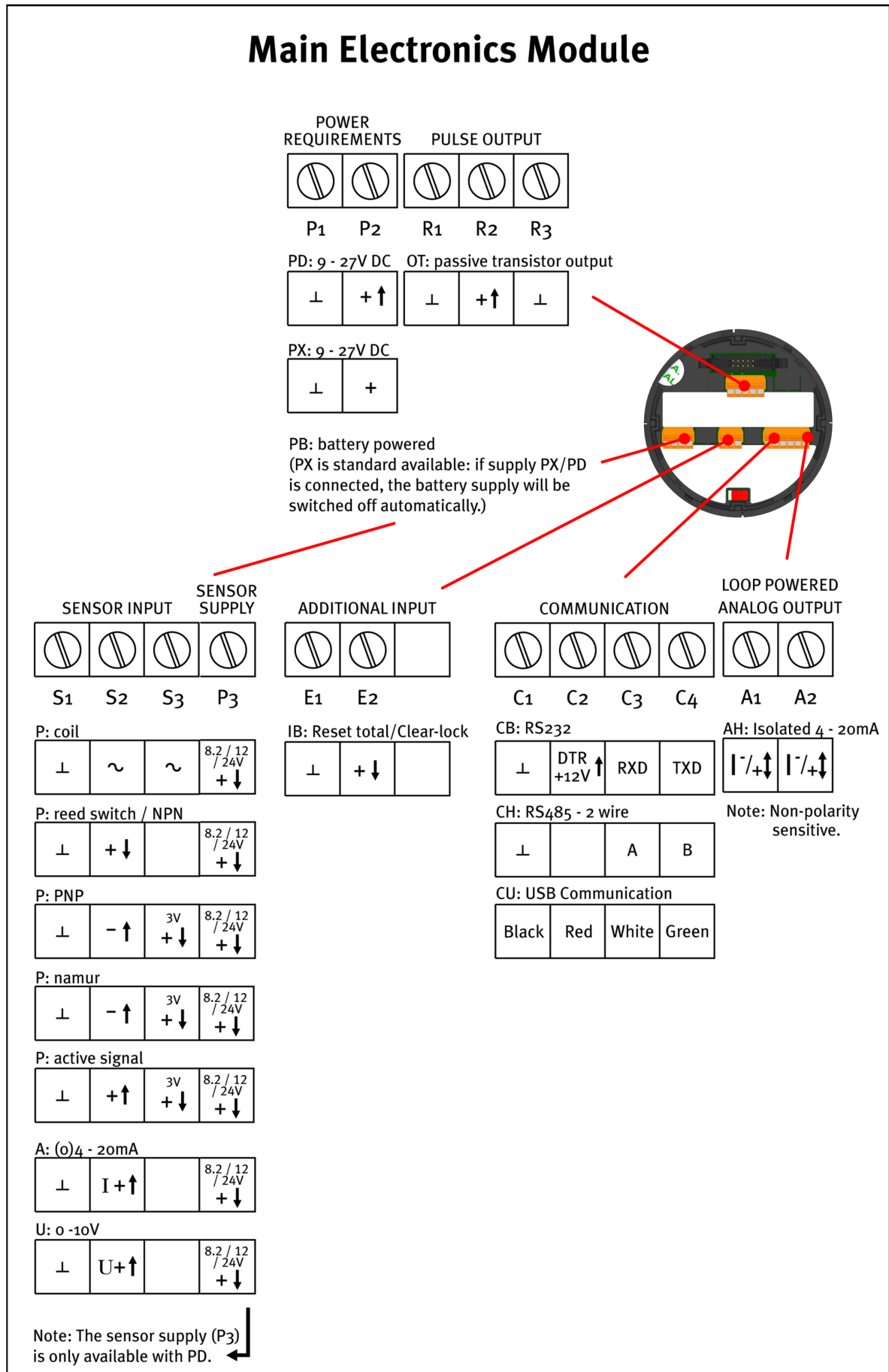
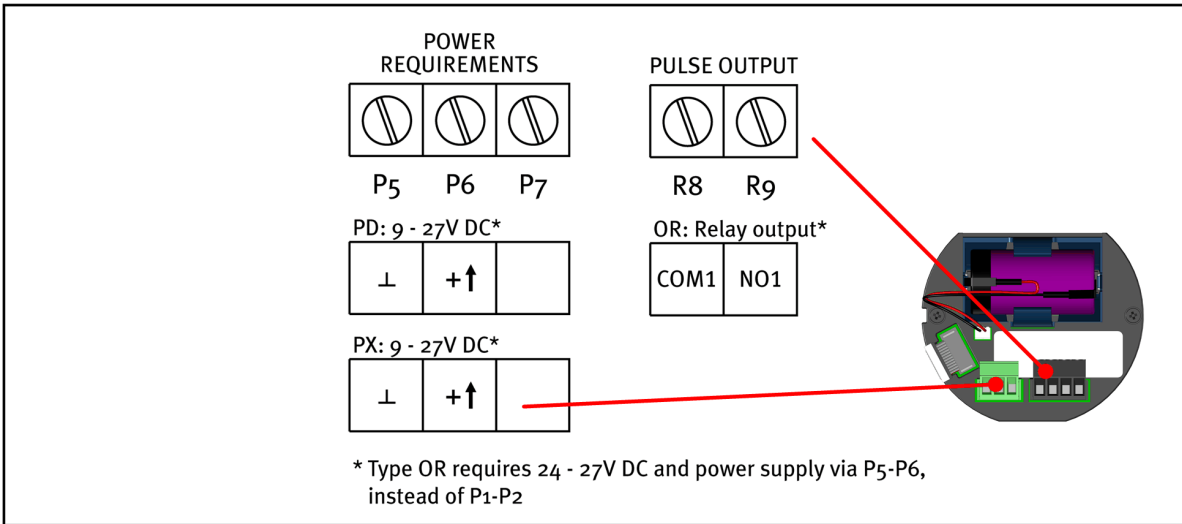

Fig. 13: Terminal connectors MEM – standard and options.

The following terminal connectors are available for the option OR – Mechanical relays (RSM Relay Supply Module):

## Supply Module



**Fig. 14: Terminal connectors RSM module.**

### 4.6 TERMINAL CONNECTIONS

#### Terminal P1-P2 and P5-P6: Power Supply – type PD/PX

Connect an external power supply of 9-27VDC to these terminals.

When power is applied to these terminals, discharge of the (optional) internal battery will be disabled. See also 4.4.6: VOLTAGE SELECTION SENSOR SUPPLY.

Power requirements for sensor supply P3:

- 8.2V sensor supply requires 9-27V;
- 12V sensor supply requires 13-27V;
- 24V = V-input – 1V (max 27V).

#### Terminal R1-R2 / R8-R9; (scaled) pulse output R1

Setup 7 (par. 3.2.10) determines the pulse output function. The maximum pulse frequency of this output is 500Hz.

#### Type OT

A passive transistor output is available with this option. Max. driving capacity 300mA@50V DC.



Note !

*R1 is a common ground (GND) terminal.*

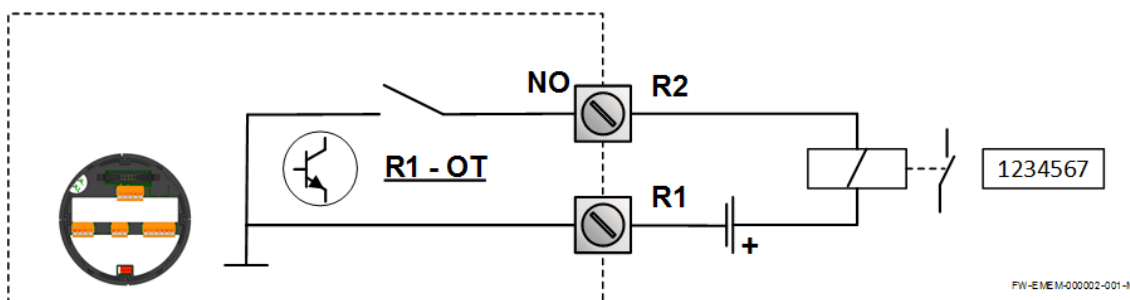

**Fig. 15: Terminal connections – Passive output R1.**

**Type OR**

The functionality of the relay outputs are programmed through the SETUP menu, see par. 3.2.10 for more details. Max. switch power 240V 0,5A per output.

Be sure that the output frequency does not exceed 0.5Hz, else the relay life time and reliability will be reduced significantly.



Note !

- If the OR option is present use power supply terminals P5-P6.
- With OR option the required supply voltage is 24 - 27V DC!

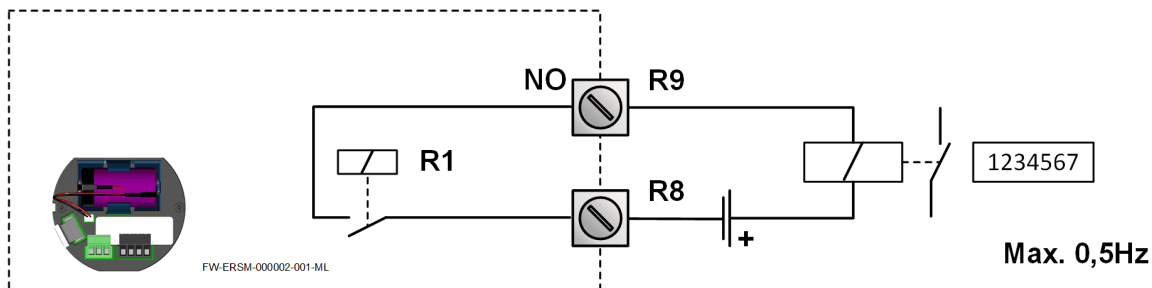

Fig. 16: Terminal connections – Mechanical relay output R1.

**Terminal S1-S3; Flowmeter inputs**

Three basic types of flowmeter signals can be connected to the unit: pulse, active pulse or sine-wave (coil). The screen of the signal wire must be connected to the common ground terminal (unless earthed at the sensor itself).

The sensor output should match with the selected flowmeter setting during SETUP (read par. 3.2.7).

**Sine-wave signal (Coil)**

The E112-P is suitable for use with flowmeters which have a coil output signal.

Two sensitivity levels can be selected with the SETUP-function:

- COIL LO: sensitivity 90mVpp.
- COIL HI: sensitivity 20mVpp.
- Type ZF offers for setting COIL HI: sensitivity 10mVpp.
- Type ZG offers for setting COIL HI: sensitivity 5mVpp.

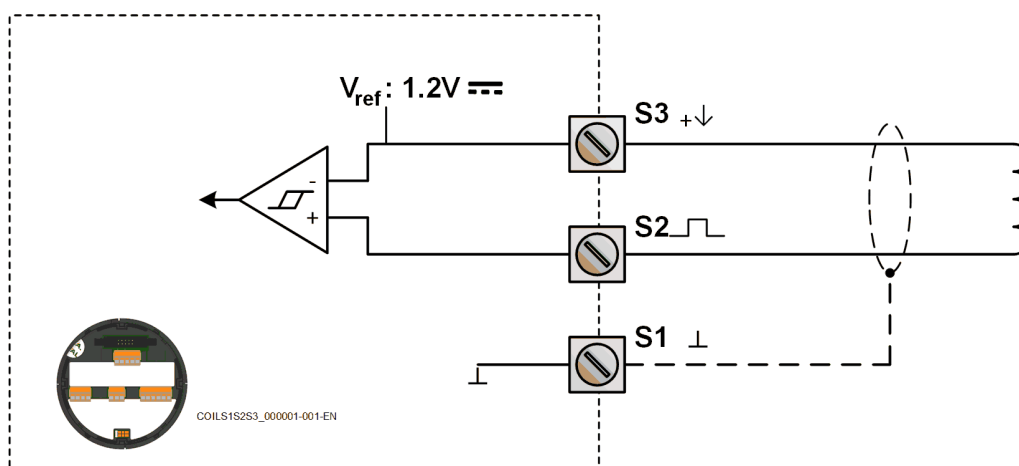
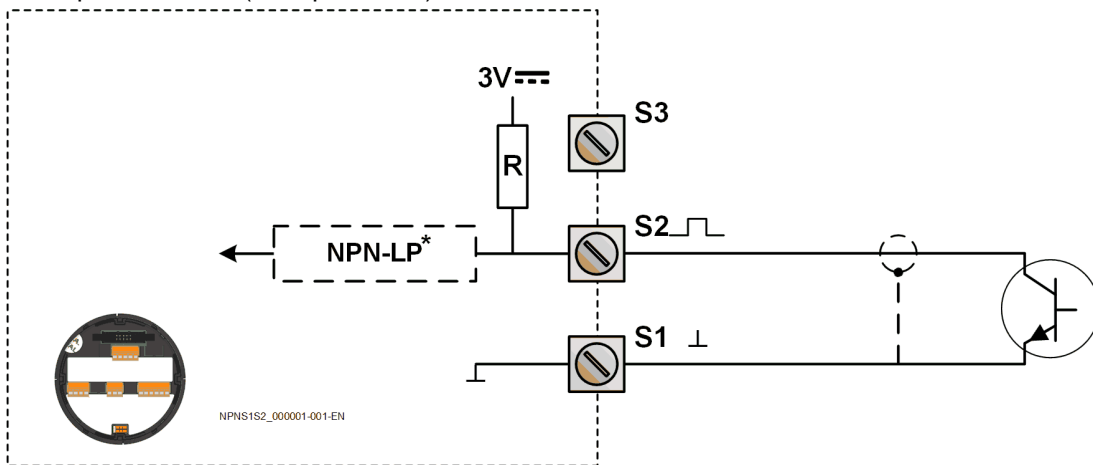

Fig. 17: Terminal connections – Coil signal input.

**Pulse-signal NPN / NPN-LP**

The E112-P is suitable for use with flowmeters which have a NPN output signal. For reliable pulse detection, the signal should be above 1.4V or below 1.0V under all circumstances. It is advised to use a sensor which is normally open and is closed for a small time (less power consumption). For better noise immunity and if no high sensor input frequencies are expected it is advised to select signal setting NPN-LP – low-pass signal noise filter which limits the maximum input frequency, to avoid pulse bounce (read par. 3.2.7).

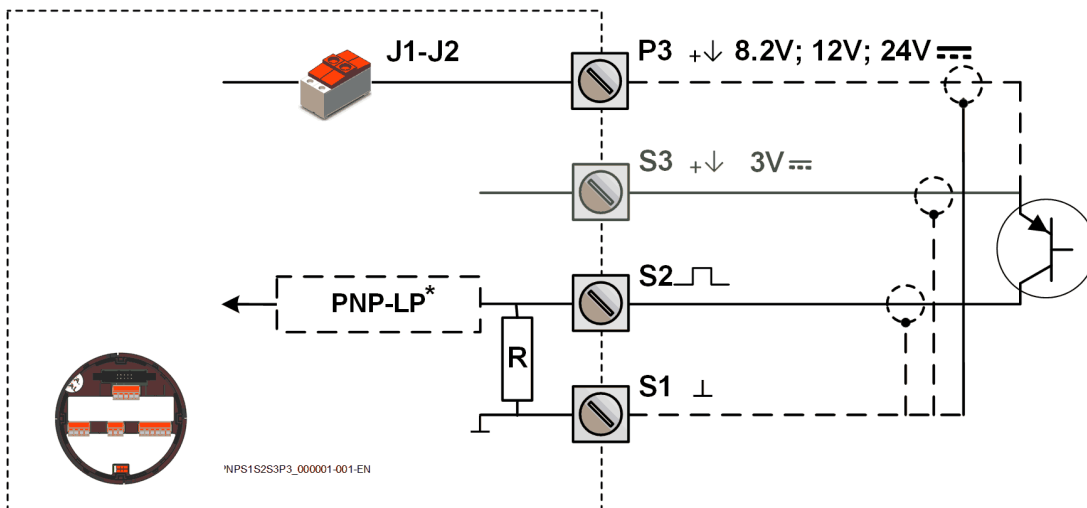

**Fig. 18: Terminal connections – NPN signal input.**

**Pulse-signal PNP / PNP-LP**

The E112-P is suitable for use with flowmeters which have a PNP output signal. 3.0V is offered on terminal S3 which has to be switched by the sensor to terminal S2 (SIGNAL). For reliable pulse detection, the signal should be above 1.4V or below 1.0V under all circumstances. It is advised to use a sensor which is normally open and is closed for a small time (less power consumption). For better noise immunity and if no high sensor input frequencies are expected it is advised to select signal setting PNP-LP – low-pass signal noise filter which limits the maximum input frequency, to avoid pulse bounce (read par. 3.2.7).

A sensor supply voltage of 8.2, 12 or 24V DC can be provided with power supply type PD.



**Fig. 19: Terminal connections – PNP signal input.**

### Reed-switch

The E112-P is suitable for use with flowmeters which have a reed-switch. To avoid pulse bounce from the reed-switch, it is advised to select REED LP – low-pass noise filter, which limits the maximum input frequency (read par. 3.2.7). Make sure the contact resistance of the reed switch is less than  $1V@2\mu A=500k\ \Omega$ .

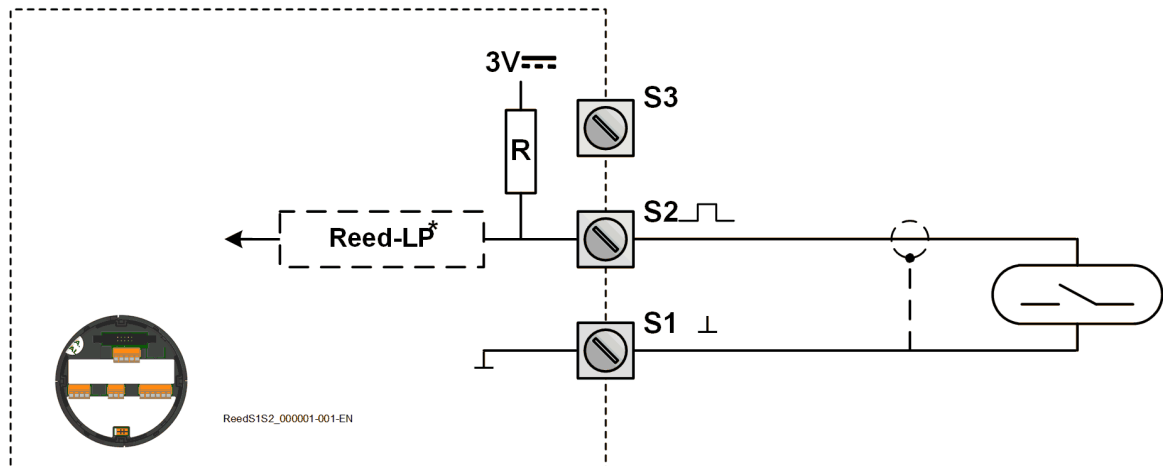

Fig. 20: Terminal connections – Reed-switch signal input.

### NAMUR-signal

The E112-P is suitable for flowmeters with a NAMUR signal. The standard E112-P-PX is not able to power the NAMUR sensor. If required the NAMUR sensor can be supplied via the 8.2V sensor supply (terminal P3), only available with power supply type PD. See paragraph 3.2.7 for more information.

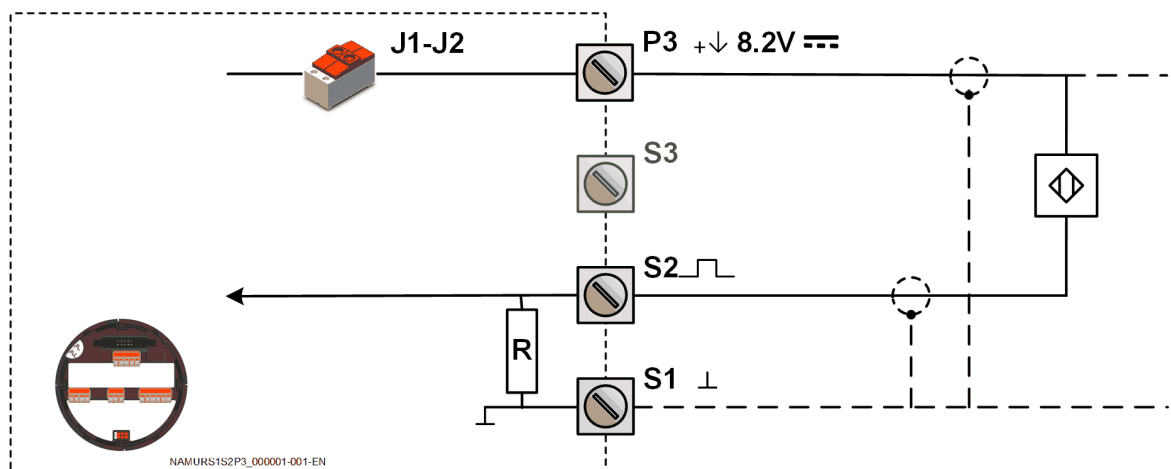

Fig. 21: Terminal connections – NAMUR signal input.

**Active signals 8.2V and 24V**

The E112-P is suitable for flowmeters with an Active signal. The detection levels are about 50% of the selected supply voltage; approximately 4V (ACT\_8.1) or 12V (ACT\_24). See par. 3.2.7 for more information.

Active signal selection may be desired in the case of power supply type PD being supplied for sensor supply.

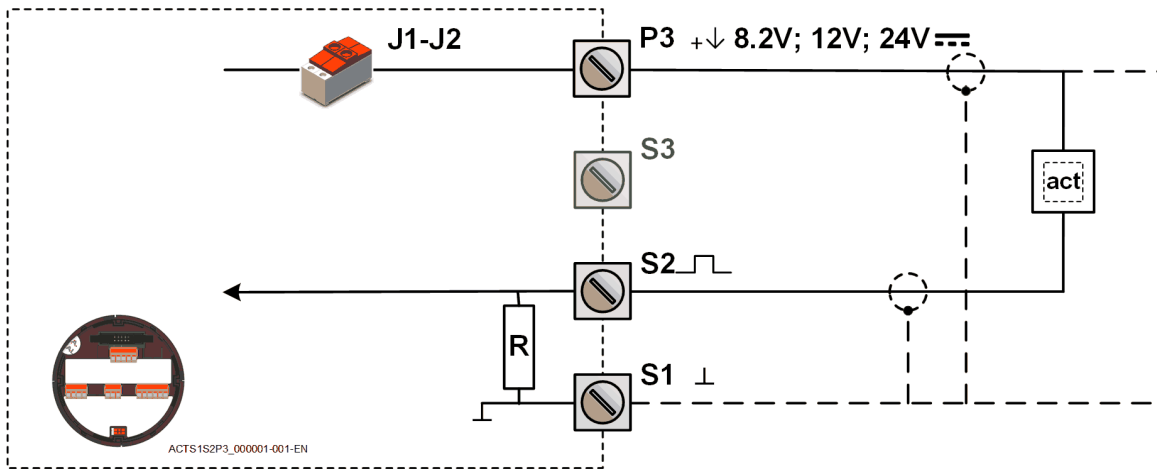

Fig. 22: Terminal connections – Active signal input.

**Terminal E1-E2 – External Reset with clear-lock- Type IB**

With this function the total can be reset to zero with an external switch. The total resets at the moment a falling edge is detected (the moment the switch *closes*).

To disable the function "Clear Total" through the glass (IR keys - see chapter 2), keep this input closed.

Make sure the contact resistance of the switch is less than  $0.8V @ 2\mu A = 400k \text{ Ohm}$ . A reset pulse should last for at least 200ms

The input must be switched with a normally open contact to GND.

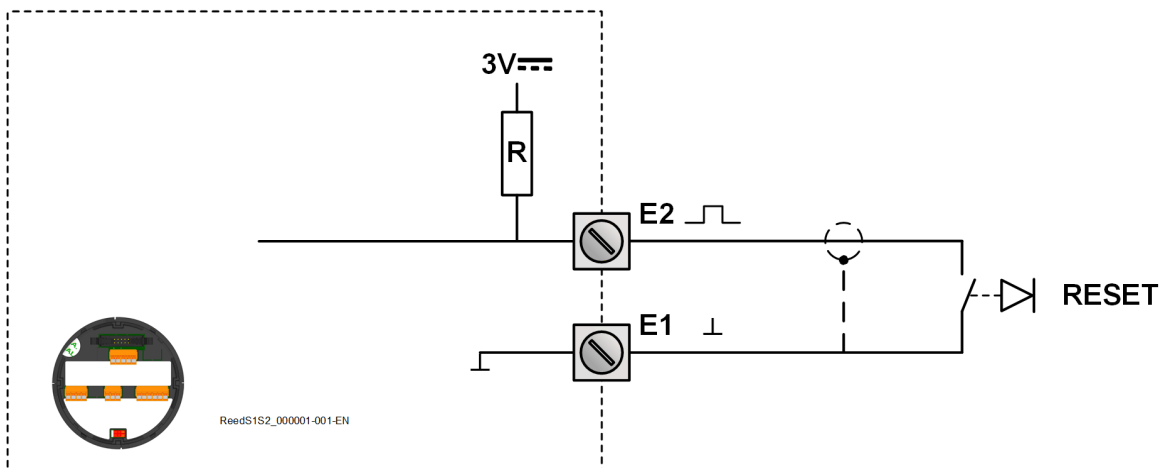

Fig. 23: Terminal connections – External reset input.

**Terminal C1-C4 – Communication RS232/RS485 (option) – Type CB/CH**

- Serial communications on hardware layers RS232 (length of cable max. 5 meters), RS485 (length of cable max. 1200 meters) and USB (max 5 m) are possible. Make sure that the hardware layer specific requirements are met to achieve reliable communication.
- Read the Modbus communication protocol and Appendix C.

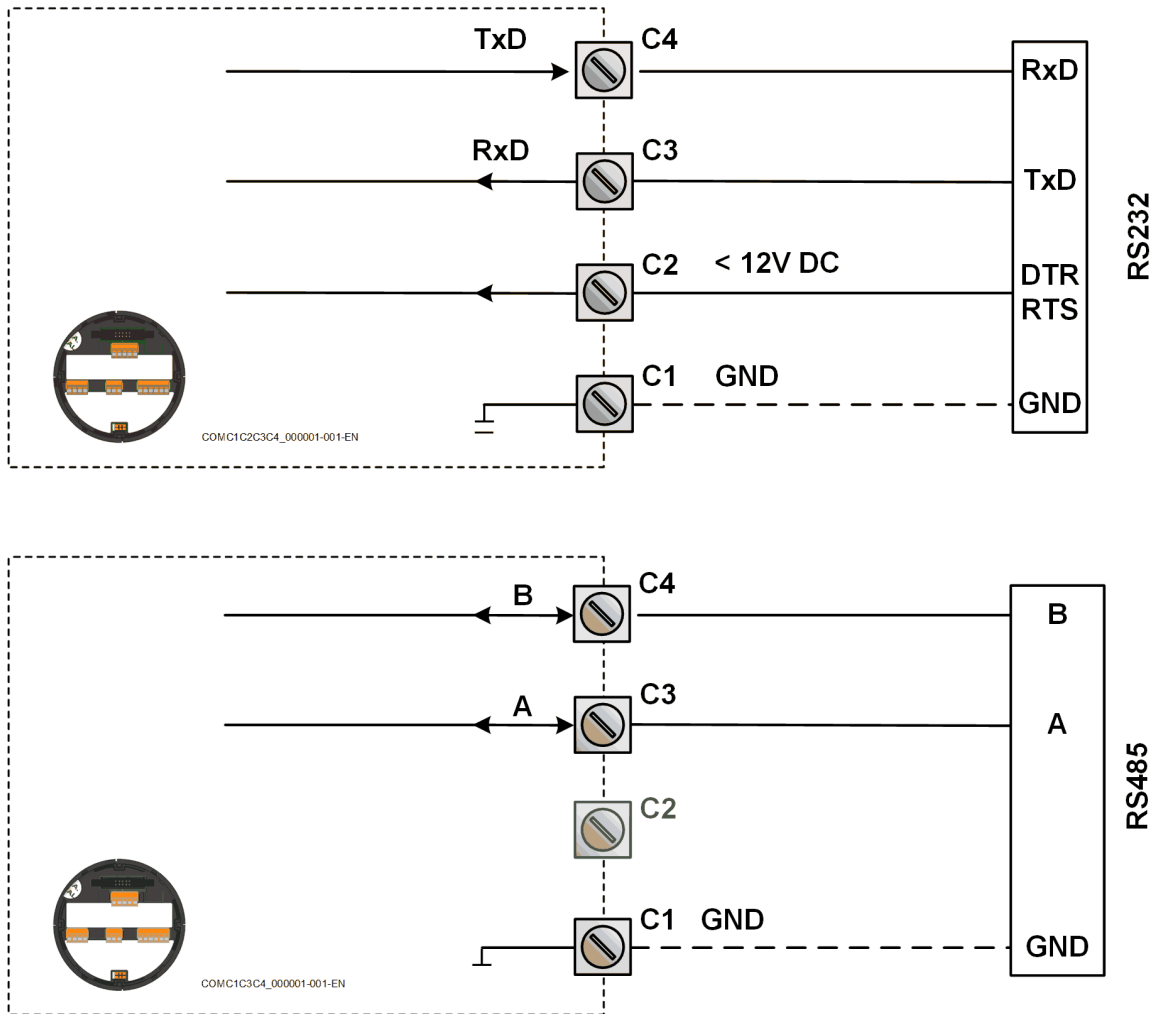

Fig. 24: Terminal connectors – Communication connector overview.

When using the RS232 communication option, terminal C2 can be used for supplying the interface. Please connect the DTR (or the RTS) signal of the interface to this terminal and set it active (current limited +12V). If no active signal is available it is possible to connect a separate supply between terminals C1 and C2 with a voltage between 6V and 10V.

**Terminal A1-A2 Isolated analog output (type AH)**

The flowrate proportional output (AH) is standard available. This output is an isolated 4-20mA output with the possibility to power the device via the 4-20mA loop. It is Non-polarity sensitive.

When the output is disabled, the current is by default limited to 2mA. Max. driving capacity 1000 Ohm @ 27V DC. If only powered by the loop the backlight will not be activated.

The total loop resistance may not exceed 1000 Ohm and may not be less than 330 Ohm (at 30mA). This makes that the resistance of other loop-devices in total may not exceed 670 Ohm. E.g. 18Vdc allows 250 Ohm.

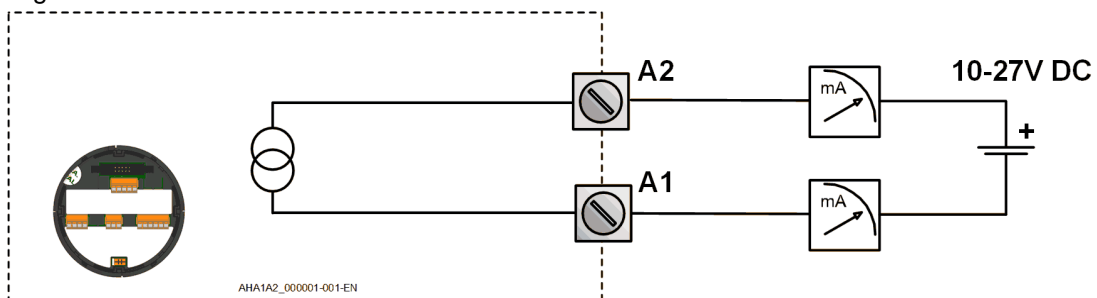

Fig. 25: Terminal connections – Isolated 4-20mA analog output.

## 5 MAINTENANCE

### 5.1 GENERAL DIRECTIONS



- Mounting, electrical installation, start-up and maintenance of the instrument may only be carried out by trained personnel authorized by the operator of the facility. Personnel must read and understand this Operating Manual before carrying out its instructions. Take careful notice of the “Safety rules, instructions and precautionary measures” in the front of this manual.
- The E112-P may only be operated by personnel who are authorized and trained by the operator of the facility. All instructions in this manual are to be observed.
- Ensure that the measuring system is correctly wired up according to the wiring diagrams. The housing may only be opened by trained personnel.
- Take careful notice of the “Safety rules, instructions and precautionary measures” in the front of this manual.

The E112-P does not require special maintenance unless it is used in low-temperature applications or surroundings with high humidity (above 90% annual mean). It is the users responsibility to take all precautions to dehumidify the internal atmosphere of the E112-P in such a way that no condensation will occur, for example by placing dry silica-gel sachet in the casing just before closing it. Furthermore, it is required to replace or dry the silica gel periodically as advised by the silica gel supplier.



*Due to incompatibility do not use silica gel in environments where Hydrogen fluoride, strong acids and strong bases are to be expected.*

#### Battery life-time



*It is strongly advised to use only necessary functions.  
E.g. disable analog output signal if not in use.*

It is influenced by several issues :

- Display update: fast display update uses significantly more power.
- Pulse output.
- Low temperatures; the available power will be less due to battery chemistry.
- NPN and PNP inputs consume more energy than coil inputs.
- High input frequency.
- Communication.
- Optical key activity.

#### Check periodically

- The condition of the enclosure, cable glands and front panel.
- The input/output wiring for reliability and aging symptoms.
- The process accuracy. As a result of wear and tear, re-calibration of the flowmeter might be necessary. Do not forget to re-enter any subsequent K-factor alterations.
- The indication for low-battery.
- Clean the enclosure with a lint-free cloth, soaked with a mild soap solution or fresh water.

### 5.2 INSTRUCTIONS FOR REPAIR

This product cannot be repaired by the user and must be replaced with an equivalent certified product. Repairs are only allowed to be carried out by the manufacturer or his authorized agent.

## 5.3 OPEN AND CLOSE THE E-SERIES

### 5.3.1 REMOVE THE COVER

1. Make the E-Series and the environment safe.
2. Unlock the set screw (2) to release the cover (3).
3. Use a wrench to turn the cover (3) counter-clockwise to release the cover (3).
4. Mind the Main Electronics Module (4) and carefully remove the cover (3) from the housing (1).
5. Keep the cover (3), with the glass facing upwards, in a clean and safe location.

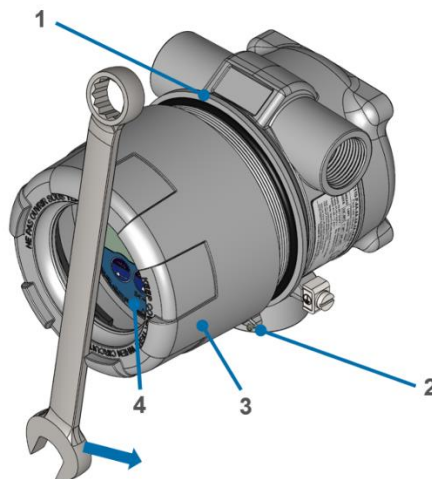

### 5.3.2 INSTALL THE COVER

1. On the first two wire threads and O-ring, apply a very thin layer of the specified anti-seize compound.
2. Hold the cover (3) in the correct position for installation.
3. By hand, turn the cover (3) clockwise onto the housing (1) until the O-ring is tight to meet the required IP or TYPE protection rating.
4. Refer to chapter: Remove the cover; Lock the cover with the set screw (2) to safety the cover (3).

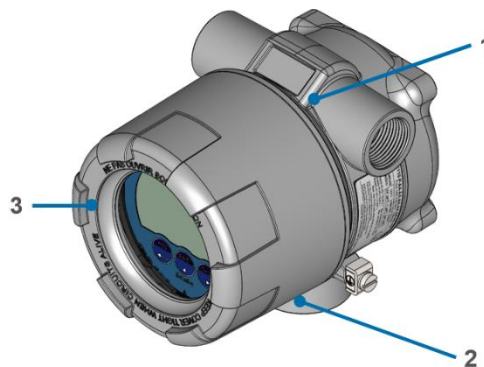

## 5.4 BATTERY REPLACEMENT – SUPPLY MODULE (IF INSTALLED)



Note !

*This procedure assumes the E-Series and the environment are made safe.*

*This procedure assumes, the E-Series is opened..*

### 5.4.1 REMOVE THE MAIN ELECTRONICS MODULE (MEM)

1. Mind the wiring and carefully, pull to remove the MEM (4) from the housing (1).
2. Unlock and carefully disconnect the flatcable connector (7). Note that the MEM goes off.
3. Disconnect the connectors (6) from the MEM (4).
4. Protect the connectors (6, 7) against the ingress of contamination.
5. Keep the MEM (4) in a clean and safe location.

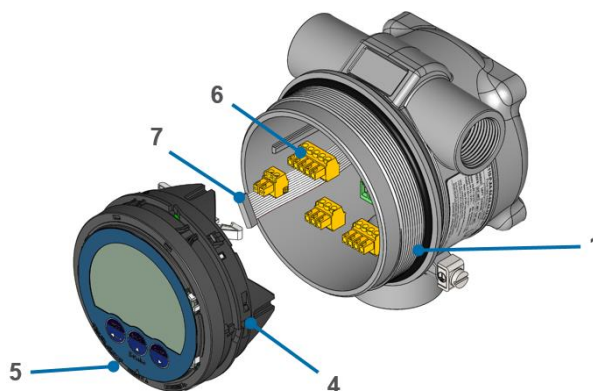

#### 5.4.2 REMOVE THE BATTERY FROM THE BASIC SUPPLY MODULE (BSM)

1. Disconnect the connector (13) from the BSM (8).
2. Carefully, remove the battery (12) from the battery holder (11).
3. As applicable discard or keep the battery (12) and the BSM (8) in a clean and safe location.

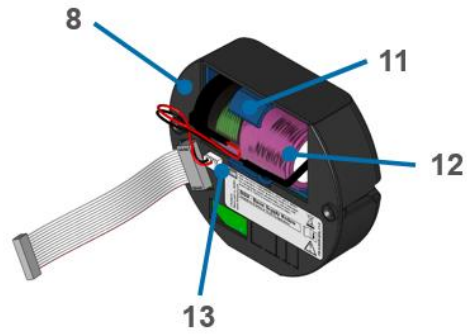

#### 5.4.3 INSTALL THE BATTERY IN THE BASIC SUPPLY MODULE (BSM)



**Handle the battery with care. A mistreated battery can become unsafe. Unsafe batteries can cause (serious) injury to persons.**

1. Unpack the new battery (12).
2. Make sure, the new battery (12) shows no signs of damage or overheating.
3. Hold the battery (12) in the correct position for installation.
4. Carefully, install the battery (12) in the battery holder (11).
5. Carefully, install the connector (13).

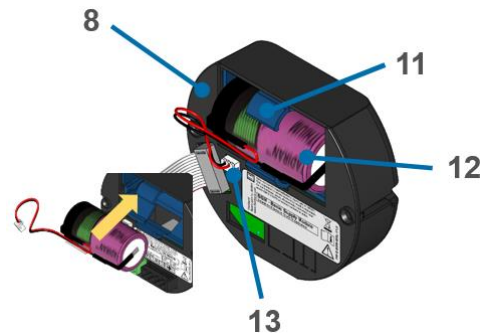

#### 5.4.4 REMOVE THE BATTERY FROM THE RELAY SUPPLY MODULE (RSM)

1. Disconnect the connector (13) from the RSM (8).
2. Carefully, remove the battery (12) from the battery holder (11).
3. As applicable discard or keep the battery (12) and the RSM (8) in a clean and safe location.

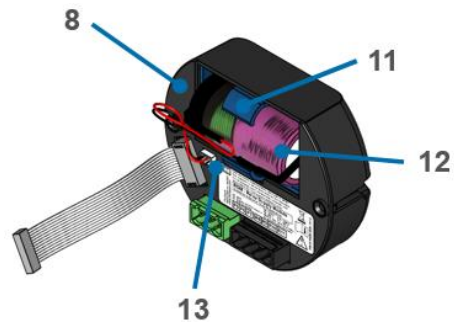

#### 5.4.5 INSTALL THE BATTERY IN THE RELAY SUPPLY MODULE (RSM)



**Handle the battery with care. A mistreated battery can become unsafe. Unsafe batteries can cause (serious) injury to persons.**

1. Unpack the new battery (12).
2. Make sure, the new battery (12) shows no signs of damage or overheating.
3. Hold the battery (12) in the correct position for installation.
4. Carefully, install the battery (12) in the battery holder (11).
5. Carefully, install the connector (13).

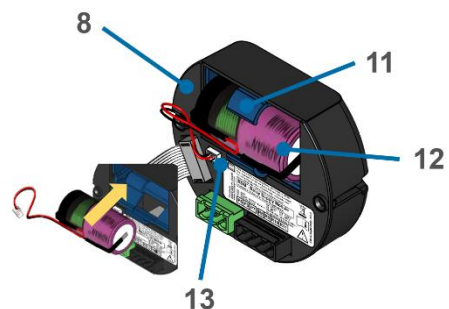

#### 5.4.6 INSTALL THE MAIN ELECTRONICS MODULE (MEM)

1. Install the connectors (6, 7) to the MEM (4).
2. Lock the flatcable connector (7) by hand and note that the MEM (4) comes on.
3. Hold the MEM (4) in the correct position for installation.
4. Mind the wiring and carefully move the MEM (4) into the housing (1).

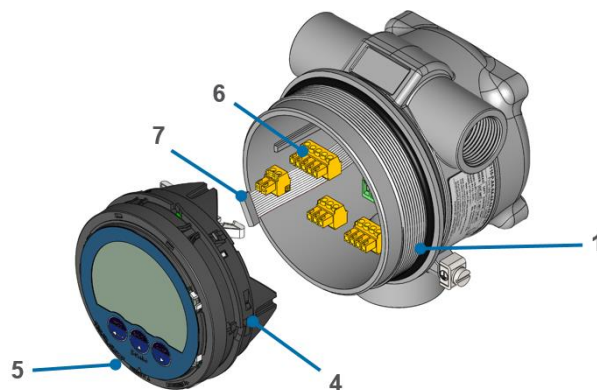

#### 5.4.7 TEST AND ADJUST THE E112-P



Note !

*This procedure assumes that the E112-P is serviceable.*

ACTION	RESULT	NOTICE
1. Make sure, the battery level indicator does not show.	<ul style="list-style-type: none"> <li>The battery indicator is off.</li> </ul>	Only replace with original batteries supplied by the manufacturer.
2. At the side, press the PROG button for at least 7 seconds.	<ul style="list-style-type: none"> <li>The SETUP indicator comes on continuously.</li> <li>The setup menu 1 shows.</li> </ul>	After a short period of time, the backlight goes off. This is normal behavior to save the battery power.
3. At the side, press the ► button.	<ul style="list-style-type: none"> <li>The setup menu 2 shows.</li> </ul>	
4. At the side, press the ▲ button.	<ul style="list-style-type: none"> <li>The setup menu 21 shows.</li> </ul>	
5. At the side, press and hold the PROG button for at least 3 seconds.	<ul style="list-style-type: none"> <li>The display goes to the operation menu.</li> </ul>	The E112-P is ready for daily use.
6. Install the cover.	<ul style="list-style-type: none"> <li>The cover is installed and locked.</li> </ul>	

#### 5.4.8 JOB CLOSE UP

1. Do a test of the optical keys to make sure the E112-P is ready for daily use.
2. Remove all tools, materials and equipment from the work area.
3. Make sure, the work area is clean.
4. Dispose of the (electronic) waste in accordance with the (inter)national, the manufacturer's and the plant owner's standards and regulations.
5. For future reference, make a note in the maintenance log of the installation.
6. Ask the safety officer for permission to return the E112-P into service.
7. Return the E112-P into service.

## 6 LABEL INFORMATION

### 6.1 GENERAL REMARKS REGARDING THE SHOWN LABELS

Two labels will be fitted on the E-series enclosure: one showing the certification data, the other showing the thread sizes, type number, serial number and address applied.



The labels below show a typical example for recognition. For the actual data, refer to the label which is attached to your unit or refer to the Appendix A; Technical specifications.

### 6.2 LABEL WITH CERTIFICATION DATA

The E-series comes in temperature class T6. T6 classified versions consume 4.5 watts or less.

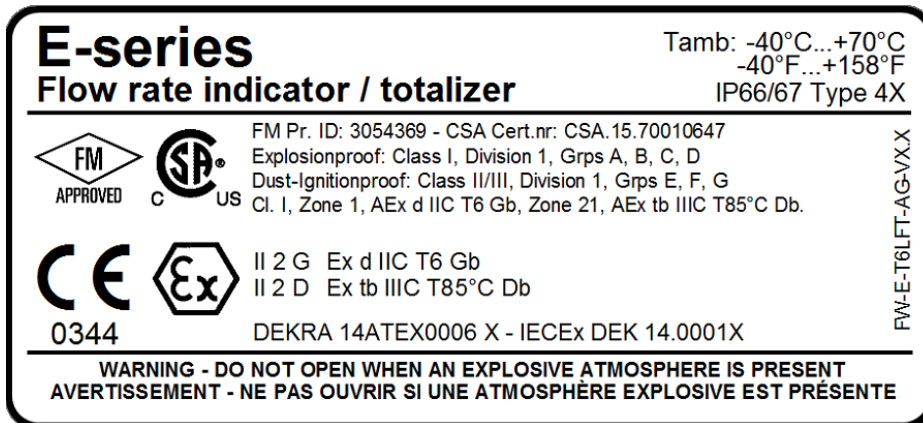

Fig. 26: External label Certification Data.

### 6.3 LABEL WITH THREAD SIZES.

The thread sizes will be indicated on the label as per the drawings below.

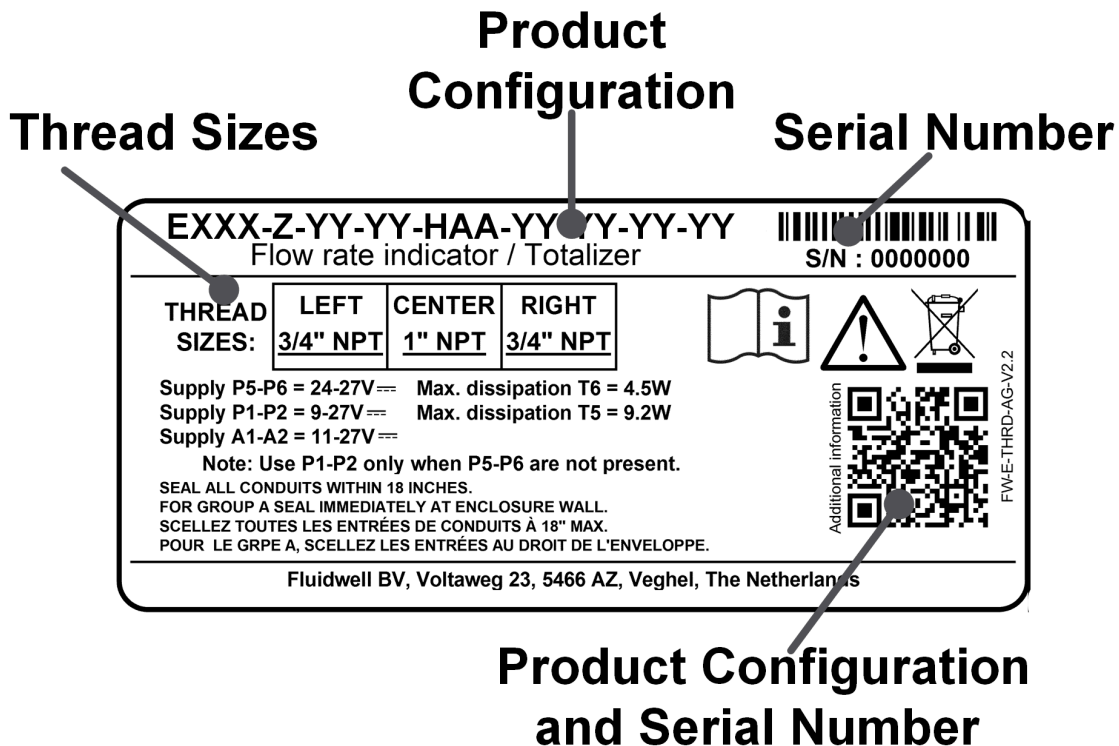

Fig. 27: Example external label Thread Sizes.

### 6.4 INTERNAL LABELS.

#### Label on the main electronics module (MEM):

The labels below are to be found on the main electronics module and supply modules inside the enclosure.

#### Labels attached to the Main Electronics Module (MEM) (typical example):

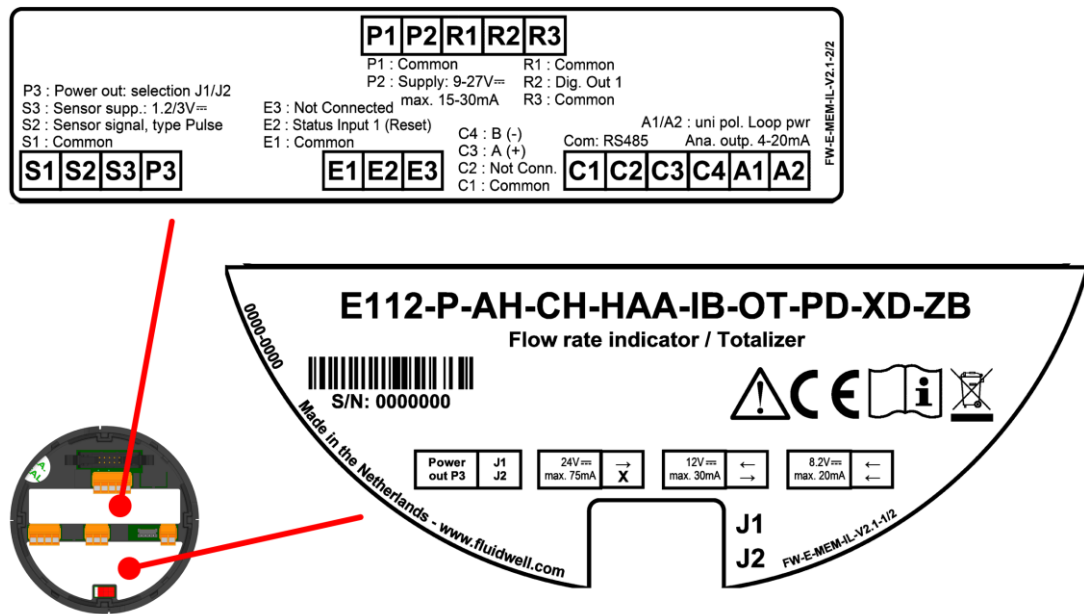

Fig. 28: Example label Main Electronic Module (MEM).

#### Label attached to the Basic Supply Module (BSM) – option PB.

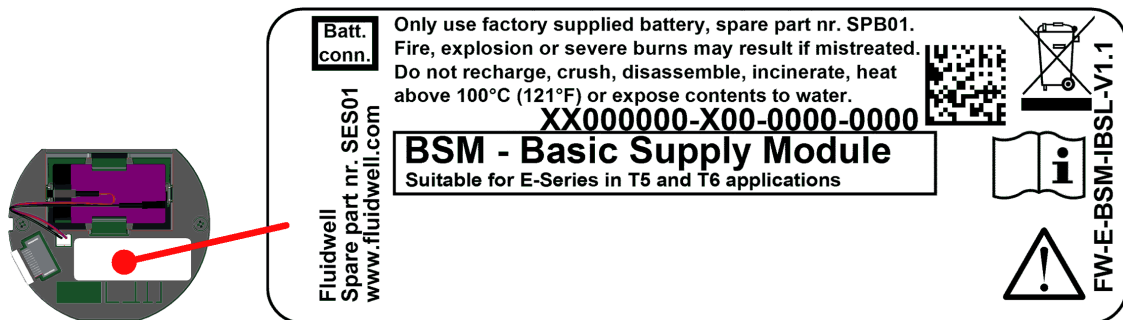

Fig. 29: Example Label Basic Supply Module (BSM).

#### Label attached to the Relay Supply Module (RSM) – option (PB)-OR.



Fig. 30: Example Label Relay Supply Module (RSM).

## Appendix A. TECHNICAL SPECIFICATION

Display	
Type	High intensity numeric and alphanumeric LCD, UV-resistant, with bright backlight. Intensity can be adjusted via the keypad. <i>When battery powered, the backlight is only operational after a keypad touch to extend the battery lifetime.</i>
Dimensions	Ø 65 x 45mm (2.56" x 1.77").
Digits	Seven 12mm (0.47") and eleven 7mm (0.28"). Various symbols and measuring units.
Refresh rate	User definable: 8 times/sec – 30 secs.
Speedometer	To indicate the actual flow rate, the bargraph runs from 0 to 100% in 20 blocks, each block is 5%.

Enclosures	
General	Aluminum or stainless steel EX-d enclosure with glass window.
Sealing	Silicone.
Control Keys	Three optical keys with operation through the glass front window.
Rating	IP66 / 67 / TYPE 4X / TYPE 7 / TYPE 9.
Type	Die-cast aluminum EX d enclosure.
HA_ Dimensions	112 x 133 x 148mm (4.41" x 5.24" x 5.83") – W x H x D.
Weight	1300 gr.
HS_ Dimensions	Stainless steel 316L Ex d enclosure.
Weight	112 x 133 x 148mm (4.41" x 5.24" x 5.83") – W x H x D. 3600 gr.
Entry thread	H_A 2 x ¾"NPT / 1 x 1"NPT H_B 3 x ¾"NPT H_C 2 x ½"NPT / 1 x 1"NPT H_D 2 x ½"NPT / 1 x ¾"NPT H_G 2 x M20 / 1 x M25 H_H 3 x M25

Operating temperature	
Ambient	-40°C to +70°C (-40°F to +158°F).

Power requirements	
Type PB	Long life Lithium battery – life-time depends upon settings and configuration –up to 44pprox.. 3 years <i>The battery can power the backlight for a short time after a keypad touch but cannot power the relay output (OR) or the real sensor supply (Terminal P3).</i>
Type PD	9 – 27V DC. Consumption max. 4.5W (sensor excitation included).
Type PX	9 – 27V DC. Consumption max. 3W.
Type AH	Loop powered, analog output. 11 – 27V DC, Min. 2mA. Consumption max. 675mW (25mA @ 27VDC). <i>The loop powered analog output cannot power the backlight, mechanical relay output (OR) or the real sensor supply (Terminal P3).</i>

Sensor excitation	
Type AH/PB/PX	Terminal S3: 3V DC for pulse signals and 1.2V DC for coil pick-up, I <sub>out</sub> max. 100µA. <i>This is not a real sensor supply. Only suitable for sensors with a very low power consumption like coils (sine wave) and reed-switches.</i>
Type PD	Terminal P3 : 8.2 / 12 / 24V DC <ul style="list-style-type: none"> <li>8.2V DC, I<sub>out</sub> max. 20mA.</li> <li>12V DC, I<sub>out</sub> max. 30mA.</li> <li>24V DC, I<sub>out</sub> max. 75mA (this voltage varies depending on the input supply voltage)</li> </ul>

Terminal connections	
Type	Removable plug-in terminal strip. Wire max. 1.5 mm <sup>2</sup> and 2.5 mm <sup>2</sup> .

Data protection	
Type	EEPROM backup of all settings. Backup of running totals every minute. Data retention at least 10 years.
Password	Configuration settings can be password protected.

Hazardous area	
ATEX	Gas : Ⓜ II 2 G Ex d IIC T6 Gb. Dust : Ⓜ II 2 D Ex tb IIIC T85°C Db.
IECEX	Gas : Ex d IIC T6 Gb. Dust : Ex tb IIIC T85°C Db.
CSA c-us	Class I, Division 1, Grps A, B, C, D Class II/III, Division 1, Grps E, F, G Class I, Zone 1, Aex d IIC T6/T5 Gb Zone 21, Aex tb IIIC T85°C/T100°C Db
FM	Class I, Division 1, Grps A, B, C, D Class II/III, Division 1, Grps E, F, G Class I, Zone 1, Aex d IIC T6/T5 Gb Zone 21, Aex tb IIIC T85°C/T100°C Db

Directives and Standards	
EMC	EN 61326-1; FCC 47 CFR part 15
LVD	EN/IEC 61010-1
ATEX / IECEX	EN/IEC 60079-0; EN/IEC 60079-1; EN/IEC 60079-31
CSA	CSA 22.2 No. 25, CSA 22.2 No. 30
FM	FM3600; FM3615; FM3616; FM3810
RoHS	EN 50581
IP & TYPE	EN 60529; NEMA 250

## INPUT

Flowmeter	
Type P	Coil / sine wave (COIL-HI: 20mVpp or COIL-LO: 90mVpp sensitivity selectable), NPN, PNP, reed switch, NAMUR, active pulse signals 8 or 24V DC.
Frequency	Minimum 0Hz - maximum 10kHz for total and flow rate. Maximum frequency depends on signal type and internal low-pass filter. E.g. reed switch with low-pass filter: max. frequency 120Hz.
K-Factor	0.000010 - 9,999,999 with variable decimal position.
Low-pass filter	Available for all pulse signals.
Option ZF	Coil sensitivity 10mVpp.
Option ZG	Coil sensitivity 5mVpp.

## Output

Digital output	
General	Pulse: Transmitting linearized accumulated total.
Frequency	Max. 500Hz. Pulse length user definable between 1msec up to 10 seconds.
Type OT	One passive transistor output (NPN) - not isolated. 300mA - 50V @ 25°C.
Type OR	One isolated electro-mechanical relay output (NO). Maximum resistive load: 2A @ 250V AC / 30V DC. Maximum inductive load: 0,5A (pilot duty applications). <ul style="list-style-type: none"> <li>Requires 24 - 27V DC and supplied via P5 - P6. Frequency max. 0,5Hz.</li> <li>Type OT remains available.</li> </ul>



Note !

Analog output	
General	Transmitting linearized flow rate.
Type AH	Galvanically isolated, loop powered 4 - 20mA output.
Accuracy	12 bit. Error 0.03% @ 20°C (Typical 45ppm/°C). Can be scaled to any desired range.

Communication (option)	
Function	Reading display information, reading / writing all configuration settings and data log extraction.
Type CB	Modbus RTU - RS232
Type CH	Modbus RTU - RS485 2-wire, bus termination without resistor for low power solutions
Type CU	USB communication incl. Ex d plug
 Note !	Requires 3/4"NPT or M25 side entry thread.
Type CX	No communication, remote configuration possible with accessory cable ACE02.
Speed [baud]	1200 - 2400 - 4800 - 9600 - 9600HP - 19200 - 38400
Addressing	maximum 247 addresses.

## Operational

Operator functions	
Displayed information	<ul style="list-style-type: none"> <li>• Indicating speedometer for flow rate.</li> <li>• Total can be reset to zero.</li> <li>• Flowrate, total and accumulated total are linearized.</li> </ul>

Total	
Digits	7 digits.
Unit	L, m3, US gal, igital, cf, Oil bbl, kg, ton, US ton, lb or none.
Decimals	0 - 1 - 2 or 3.
 Note !	Total can be reset to zero.

Accumulated total	
Digits	11 digits.
Unit / decimals	According to selection for total.
 Note !	Accumulated total cannot be reset to zero.

Flow rate	
Digits	7 digits.
Units	mL, L, m3, mg, g, kg, ton, US ton, US gal, igital, Oil bbl, lb, cf, rev, none, scf, nm3, nL or p.
Bargraph speedometer	20 blocks, each block is 5% of total span
Decimals	0 - 1 - 2 or 3.
Time units	/sec - /min - /hr - /day.

## Appendix B. PROBLEM SOLVING

In this appendix, several problems are included that can occur when the E112-P is going to be installed or while it is in operation.

### Flowmeter does not generate pulses

Check:

- Signal selection SETUP – 4.1,
- Pulse amplitude (par. 4.4.3.),
- Flowmeter, wiring and connection of terminal connectors (par. 4.4.3.),
- Power supply of flowmeter (par. 4.4.2.).

### Flowmeter generates "too many pulses"

Check:

- Settings for Total and Flowrate,
- Type of signal selected with actual signal generated.
- Sensitivity of coil input.
- Proper grounding of the E112-P, avoid ground loops.
- Use screened wire for flowmeter signals and connect screen to the ground input terminal of the flowmeter input.

### Analog output does not function properly

Check:

- SETUP 6.1 - is the function enabled?
- SETUP 6.2 / 6.3: are the flow-levels programmed correctly?
- Connection of the external power-supply according to the specification.

### Pulse output does not function

Check:

- SETUP 7.1 - pulse per "x" quantity; is the value programmed reasonable?
- SETUP 7.2 - impulse width; is the external device able to recognize the selected pulse width and frequency?

### Flowrate displays "0 / zero" while there is flow (total is counting)

Check:

- SETUP 2.2 / 2.5: are the K-factor and time unit correct?
- SETUP 2.6 / 2.7: The unit has to count the number of pulses according to SETUP 2.6 within the time according to SETUP 2.7. Make sure that 2.7 is set to 10.0 seconds for example: the result is that the unit has at least 10 seconds time to measure the number of pulses according to SETUP 2.6.

### Linearization does not work

Check:

- SETUP 5.G: is the function enabled?
- SETUP 5.1-5.F: are all M-Factors and the frequency entered correctly?

### The password is unknown

If the password cannot be retrieved, there is only one possibility left: call your supplier.

### ALARM

When the alarm flag starts to blink an internal alarm condition has occurred. Press the "select button" several times to display the error code. The codes are:

0001:	PCF error
0002:	EEPROM ERROR
0004:	INITIALISATION ERROR
0016:	IO EXPANDER BASE ERROR
0032:	IO EXPANDER INTERFACE ERROR
0064:	LINEARIZATION ERROR
0128:	KFACTOR CONVERSION ERROR
0008:	EEPROM LOG ERROR (option ZL only)

If the alarm occurs more often or stays active for a long time, please contact your supplier.

## Appendix C. MODBUS COMMUNICATION

### General

The product is fitted with the Modbus communication protocol and can be equipped with various physical interfaces like RS485 and RS232 (please see device datasheet for available options). The tables below show the various variables that can be accessed through the communication.

Currently, the function codes supported are:

- function code 3 “Read Holding Registers” (4x references);
- function code 16 “Preset Multiple Registers” (4x references).

The table below shows the Modbus PDU addresses in a decimal format, followed by its hexadecimal representation (0x0000). When the PLC address range is required (4x references are typically used by PLCs), please add a value of 40001 to the Modbus PDU address. E.g. reading the serial number of the product with PLC-based addressing means: 165 + 40001 = register 40166.

**The variables that consist of a multiple register must always read/write in 1 single action!**

Refer to the illustration:

For this example it is assumed that the variable accumulated total has 3 registers (words) with address 566, 567 and 568. When a transmission is done, register 566, which acts as the MSW, arrives first with bit 15 which is the MSB of the lowest addressed word, but is also the MSB (bit 47) of the complete variable that represents the Accumulated total.

Although most Modbus Masters will support variables that span 2 registers, variables spanning more registers sometimes require you to manually calculate the resulting value.

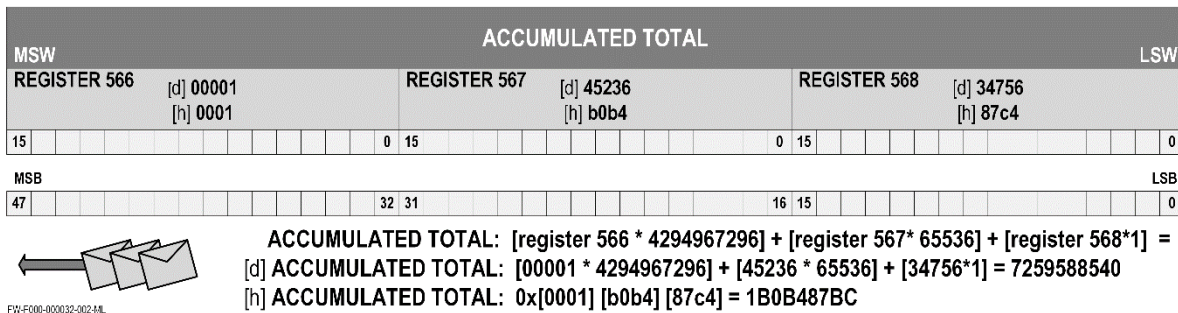

The following datatypes are used for Modbus communication with the E112-P:

Data type	Number of bytes	Number of registers (16 bit)	Description
char	1	1	8 bits ASCII character
unit16	2	1	16 bits unsigned integer
unit32	4	2	32 bits unsigned integer
unit48	6	3	48 bits unsigned integer
unit64	8	4	64 bits unsigned integer
float32	4	2	32 bits floating point
float64	8	4	64 bits floating point

For additional information regarding using your Modbus device, please read our 'General Modbus Communication Protocol' and 'Modbus troubleshooting guide' that are available through our website or your distributor.

## Runtime variables of the E112-P

Runtime variables of the E112-P – Integer based						
PDU ADDRESS	HOLDING REGISTER	VARIABLE	NO. REGISTERS	R/W	TYPE	VALUE / REMARKS
[d] 572 [h] 0x023C	40573	flow rate	2	R	uint32	0...9999999 Representation: unit, time, decimals depending on variables 48, 49, 50
[d] 6154 [h] 0x180A	46155		4	R	uint64	
[d] 566 [h] 0x236	40567	total	3	R *	uint48	0...9999999999 Representation: unit, decimals depending on variables 32, 33
[d] 6146 [h] 0x1802	46147		4	R	uint64	
[d] 560 [h] 0x0230	40561	accumulated total	3	R	uint48	0...99999999999999 Representation: unit, decimals depending on variables 32, 33
[d] 6150 [h] 0x1806	46151		4	R	uint64	
[d] 516 [h] 0x0204	40517	error status (bitfield)	1	R	uint16	[d] 0 = no error [d] 1 = display error [d] 2 = data-storage error [d] 4 = initialization error [d] 8 = data-storage error data logging (option ZL) [d] 16 = IO configuration error base [d] 32 = IO configuration error interface [d] 64 = Linearization error (M-factor out of range) [d] 128 = Automatic K-factor conversion error
[d] 255 [h] 0x0FF	40256	battery status	1	R	uint16	0 = unknown    1 = normal    2 = low battery

Runtime variables of the E112-P – Floating point based						
PDU ADDRESS	HOLDING REGISTER	VARIABLE	NO. REGISTERS	R/W	TYPE	VALUE / REMARKS
[d] 6406 [h] 0x1906	46407	flow rate	2	R	float32	0...9999999 Representation: unit and time depending on variables 48, 49
[d] 6402 [h] 0x1902	46403	total	2	R	float32	0...9999999999 Representation: unit depends on variable 32
[d] 6656 [h] 0x1A00	46657		4	R	float64	
[d] 6404 [h] 0x1904	46405	accumulated total	2	R	float32	0...99999999999999 Representation: unit depends on variable 32
[d] 6660 [h] 0x1A04	46661		4	R	float64	

Reading flowrate, total or accumulated total: The returned values are given including the decimals and represent the actual value. The given value may differ from the value that is displayed on the display – this is due to the fact that the display is limited in the number of digits and may have a slower update rate set.

For example when two decimals are selected for total and total has a value of 123456,78 the display will show 23456,78 while communication will read a “total” of 12345678 (note that the decimals should be adapted according the setting in “total decimals” which is in this case 2).

\* Clearing total: It is possible to clear the total counter by means of writing a value of 0 to all the 3 registers of total in a single write action. Writing any other value will result in the reply of an error message.

**Configuration variables of the E112-P**

Total						
PDU ADDRESS	HOLDING REGISTER	VARIABLE	NO. REGISTERS	R/W	TYPE	VALUE / REMARKS
[d] 32 [h] 0x020	40033	unit	1	R/W	uint16	0=none    3=US GAL    6= OilBBL    9=lb 1=L        4= l GAL     7=kg        10=us ton 2= m <sup>3</sup> 5=CF        8=ton
[d] 33 [h] 0x021	40034	decimals	1	R/W	uint16	0...3
[d] 34 [h] 0x022	40035	K-factor	2	R/W	uint32	1...9999999 Representation: 0.000010...9999999 depending on variable 54: decimals K-factor.
[d] 37 [h] 0x025	40038	K-factor decimals	1	R/W	uint16	0...6
[d] 47 [h] 0x02F	40048	X factor	1	R/W	uint16	0=x1        1=x10        2=x100       3=x1000
[d] 1052 [h] 0x41C	41053	clear total password	1	R/W	uint16	000 ... 999 Setting 000 disables the clear total password feature.

Flowrate						
PDU ADDRESS	HOLDING REGISTER	VARIABLE	NO. REGISTERS	R/W	TYPE	VALUE / REMARKS
[d] 48 [h] 0x030	40049	unit	1	R/W	uint16	0=none    5=l GAL        10=SCF       15=lb 1=mL       6=CF           11=mg        16=US 2=L         7=OilBBL      12=g          17=rev 3=m <sup>3</sup> 8=nL           13=kg        18=P 4=US GAL   9=nm <sup>3</sup> 14=ton
[d] 49 [h] 0x031	40050	time unit	1	R/W	uint16	0=/sec     1=/min        2=/hour       3=/day
[d] 50 [h] 0x032	40051	decimals	1	R/W	uint16	0...3
[d] 51 [h] 0x033	40052	K-factor	2	R/W	uint32	1...9999999 Representation: 0.000010...9999999 depending on variable 54: decimals K-factor.
[d] 54 [h] 0x036	40055	K-factor decimals	1	R/W	uint16	0...6
[d] 55 [h] 0x037	40056	number of pulses	1	R/W	uint16	1...255
[d] 56 [h] 0x038	40057	cut-off time	1	R/W	uint16	1...9999 Representation: 0.0001 – 9.999 sec

Display						
PDU ADDRESS	HOLDING REGISTER	VARIABLE	NO. REGISTERS	R/W	TYPE	VALUE / REMARKS
[d] 64 [h] 0x040	40065	display function	1	R/W	uint16	0=total    1=flowrate    2=acc.total
[d] 80 [h] 0x050	40081	LCD update time	1	R/W	uint16	0= fast    2=3 sec       4=30 sec 1=1 sec    3=15 sec      5=off
[d] 67 [h] 0x043	40068	backlight brightness	1	R/W	uint16	0=off      2=40%        4=80% 1=20%     3=60%        5=100%
[d] 58 [h] 0x03A	40059	bar graph enable	1	R/W	uint16	0=disable   1=enable
[d] 59 [h] 0x03B	40060	bar graph range	2	R/W	uint32	0...9999999 Representation: unit, time, decimals depending on variables 48, 49, 50

Flowmeter						
PDU ADDRESS	HOLDING REGISTER	VARIABLE	NO. REGISTERS	R/W	TYPE	VALUE / REMARKS
[d] 96 [h] 0x060	40097	flowmeter signal	1	R/W	uint16	0=NPN 3=Reed LP 6=NAMUR 9=act 8.2V 1=NPN LP 4=PNP 7=coil hi 10=act 24V 2=Reed 5=PNP LP 8= coil lo
[d] 1050 [h] 0x41A	41051	K-factor - unit	1	R/W	uint16	0=none 3=US GAL 6= OilBBL 9=lb 1=L 4= I GAL 7=kg 10=us ton 2= m <sup>3</sup> 5=CF 8=ton
[d] 1051 [h] 0x41B	41052	K-factor - unit type	1	R/W	uint16	0=Volumetric 1=Mass 2=Hand
[d] 1046 [h] 0x416	41047	K-factor	2	R/W	uint32	1...9999999 Representation: 0.000010...9999999 depending on variable 54: decimals K-factor.
[d] 1049 [h] 0x419	41050	K-factor decimals	1	R/W	uint16	0...6

PDU ADDRESS	REGISTER	VARIABLE	NO. REGISTERS	R/W	TYPE	VALUE / REMARKS
[d] 1024 [h] 0x400	41025	linearization table entry	3	R/W	struct 2x uint24	The linearization table is an INDEXED variable. Reading and writing the entries of the linearization tables is done by first selecting the entry through the index. Valid values for the index are 0...14, which correspond with the linearization table entries 1 through 15. Indexes outside this range will result in an error being sent back. (See the communication-section of this appendix for setting the index and its extended functionality through variable 150 and 149). The 3 registers represent a structure containing 2 variables of each 3 bytes. The three least significant bytes (PDU address 1024 and LSB of PDU address 1025) contain the frequency part, the three most significant bytes (MSB of PDU address 1025 and PDU address 1026) contain the M-factor part. Valid range for the frequency is 0.000 to 9999Hz. Decimal point dependent on variable 1039. A value of 0 for frequency means that entry is disabled. Valid range for the M-factor 0.000000 to 9.999999.
[d] 1038 [h] 0x40E	41039	linearization on/off	1	R/W	uint16	0=disable 1=enable
[d] 1039 [h] 0x40F	41040	decimals	1	R/W	uint16	0...3 This variable selects the number of decimals used for the frequencies entered in the linearization table.

Analog output						
PDU ADDRESS	HOLDING REGISTER	VARIABLE	NO. REGISTERS	R/W	TYPE	VALUE / REMARKS
[d] 112 [h] 0x070	40113	analog output	1	R/W	uint16	0=disable 1=enable
[d] 113 [h] 0x071	40114	minimum rate	2	R/W	uint32	0...9999999 Representation: unit, time, decimals depending on variables 48, 49, 50
[d] 116 [h] 0x074	40117	maximum rate	2	R/W	uint32	0...9999999 Representation: unit, time, decimals depending on variables 48, 49, 50
[d] 119 [h] 0x077	40120	cut off percentage	1	R/W	uint16	0...99 Representation: 0.0 – 9.9%
[d] 120 [h] 0x078	40121	tune minimum output	1	R/W	uint16	0...9999
[d] 122 [h] 0x07A	40123	tune maximum output	1	R/W	uint16	0...9999
[d] 127 [h] 0x07F	40128	filter	1	R/W	uint16	1...99

Pulse output						
PDU ADDRESS	HOLDING REGISTER	VARIABLE	NO. REGISTERS	R/W	TYPE	VALUE / REMARKS
[d] 128 [h] 0x080	40129	pulse time width	1	R/W	uint16	0...9999 Representation: 0.001 – 9.999 sec
[d] 133 [h] 0x085	40134	pulse quantity decimals	1	R/W	uint16	0...3
[d] 130 [h] 0x082	40131	pulse per X quantity	2	R/W	uint32	1...9999999 Representation: 0.000001...9999999 depending on variables 130, 32

Modbus communication						
PDU ADDRESS	HOLDING REGISTER	VARIABLE	NO. REGISTERS	R/W	TYPE	VALUE / REMARKS
[d] 144 [h] 0x090	40145	speed (baudrate)	1	R/W	uint16	0=1200    2=4800    4=9600HP    6=38400 1=2400    3=9600    5=19200
[d] 145 [h] 0x091	40146	modbus address	1	R/W	uint16	1...247
[d] 146 [h] 0x092	40147	modbus mode	1	R/W	uint16	0=off    1=RTU    2=ASCII
[d] 1271 [h] 0x4F7	41272	data bits	1	R/W	uint16	0=7 bits    1=8 bit
[d] 1272 [h] 0x4F8	41273	parity	1	R/W	uint16	0=none    1=even    2=odd
[d] 147 [h] 0x093	40148	delay	1	R/W	uint8	delay between receiving a (valid) modbus command and sending the response 0...255 ms
[d] 150 [h] 0x096	40151	index	1	R/W	uint16	used for indexed values 0...255
[d] 149 [h] 0x095	40150	index use	1	R/W	uint16	0=static    1=auto    2=auto increment    decrement
[d] 25 [h] 0x019	40026	reboot	1	R/W	uint16	Returns 0 on read. Write 0xA50F for unit restart Write 0x5AF0 for factory settings

Data logging (option -ZL only)						
PDU ADDRESS	HOLDING REGISTER	VARIABLE	NO. REGISTERS	R/W	TYPE	VALUE / REMARKS
[d] 576 [h] 0x240	40577	log interval	1	R/W	uint16	0=off    3=10 min    6=1 hour    9= 6 hours 1=1 min    4=15 min    7=2 hours    10=8 hours 2=5 min    5=30 min    8= 4 hours
[d] 577 [h] 0x241	40578	daily log	1	R/W	uint16	0=off    1=Single    2=Dual
[d] 578 [h] 0x242	40579	daily1	1	R/W	uint16	00:00 – 23:59 Representation: hh:mm Stored decimal: 23:59 = 2359d = 0x0937
[d] 580 [h] 0x244	40581	daily2	1	R/W	uint16	00:00 – 23:59 Representation: hh:mm Stored decimal: 23:59 = 2359d = 0x0937
[d] 176 [h] 0x0B0	40177	local time	2	R/W	uint32	00:00:00 – 23:59:59 Representation: hh:mm:ss Stored decimal: 23:59:59 = 235959d = 0x0003.99B7
[d] 179 [h] 0x0B3	40180	date	2	R/W	uint32	2000-01-01 – 2099-12-31 Representation: yyyy-mm-dd Stored decimal: 99-12-31 = 991231d = 0x000F.1FFF

Others						
PDU ADDRESS	HOLDING REGISTER	VARIABLE	NO. REGISTERS	R/W	TYPE	VALUE / REMARKS
[d] 160 [h] 0x0A0	40161	model number	1	R	uint16	0...9999
[d] 173 [h] 0x0AD	40174	model suffix	1	R	char	Representation: ASCII character
[d] 162 [h] 0x0A2	40163	firmware version	2	R	uint32	0...999999 Representation: xx.xx.xx
[d] 165 [h] 0x0A5	40166	serial no	2	R	uint32	0...9999999 Representation: xxxxxxx
[d] 168 [h] 0x0A8	40169	password	1	R	uint16	0...9999
[d] 139 [h] 0x08B	40140	keyboard lock	1	R/W	uint16	0=disable    1=enable
[d] 170 [h] 0x0AA	40171	tag no	2	R/W	uint32	0...9999999 Representation: xxxxxxx

# Appendix D. DECLARATION OF CONFORMITY



*Count on us.*

## EU Declaration of Conformity

### Fluidwell E-series indicators

Veghel, October 2017

We, Fluidwell BV, declare under our sole responsibility that the E-series indicators are designed and will operate conform the following applicable European Directives and Harmonised Standards, when installed and operated according to the related manual:

<b>EMC Directive</b>	<b>2014/30/EU</b>	EN61000-6-2:2005; EN61000-6-3: 2007 /A1:2011; EN61326-1:2013
<b>RoHS Directive</b>	<b>2011/65/EU</b>	EN 50581:2012
<b>Low Voltage Directive</b>	<b>2014/35/EU</b>	
	For options –PM or –OR:	EN61010-1:2010
<b>ATEX Directive</b>	<b>2014/34/EU</b>	EN60079-0:2012; EN60079-1:2007; EN60079-31:2009
	For option –XD, flame proof:	
	Protective system:	⊕ II 2 G Ex d IIC T6/T5 Gb
	(for power consumption up till 4.5 W / 9.2 W respectively)	⊕ II 2 D Ex tb IIIC T85 °C/T100 °C Db
<b>Certification</b>	Certificates:	DEKRA 14ATEX0006 X, Issue 1
	Notified body 0344:	DEKRA Certification BV, Meander 1051, 6825 MJ, Arnhem, the Netherlands.

Last two digits of the year in which the CE marking was affixed: 13.

Remark: compliance is not affected by standards EN60079-0/A11:2014, EN60079-1:2014 and EN60079-31:2014.

Fluidwell BV

I. Meij, Manager Technology

Fluidwell BV are ISO9001 certified by DEKRA Certification BV, Meander 1051, 6825 MJ, Arnhem, the Netherlands.

	<b>Fluidwell bv</b>	Telephone: +31 (0) 413 - 343 786	Trade Reg. No:	17120985	EUR account no:	66.63.96.078
	P.O. Box 6 • 5460 AA • Veghel	Telefax: +31 (0) 413 - 363 443	VAT No:	NL8085.29.699.B.01	IBAN:	NL73 INGB 0666 3960 78
	Voltaweg 23 • 5466 AZ • Veghel	Email: displays@fluidwell.com	Bank:	ING-Bank	USD account no:	02.20.81.771
	The Netherlands	Internet: www.fluidwell.com	SWIFT Nr / BIC:	INGBNL2A	IBAN:	NL22 INGB 0022 0817 71

## INDEX OF THIS MANUAL

<b>accumulated Total</b>	9	functional description	5
	58	hardware version	3
analog		Intrinsic safety	38, 39, 41
cut-off value	21	IP classification	24
disable/enable	21	keys	7
filter	22	main-function	11
flowrate max.	21	maintenance	38
flowrate min.	21	manual version	3
tune / calibrate	21	Meter Factor	20
clear total	9	NAMUR-signal	35
clear total password	9, 15	operational	7, 11, 24, 38
Coil-signal	33	Operator level	9
communication	36	power supply	32
Configuration	11	Pulse output	32
contents	4	Pulse-signal NPN/PNP	34
dimensions	25	Reed-switch:	35
display update	17	SETUP-level	11
flowmeter		software version	3
signal	18	subfunction	12
flowrate		terminal connectors	31, 32
cut-off time	17	total	
decimals	16, 22	decimals	15
measuring unit	16	decimals k-factor	15, 16, 19, 20
Flowrate	9	k-factor	19
Frequency	20	Total	9

## LIST OF FIGURES E112-P

Fig. 1: Application lay-out (typical)	5
Fig. 2: Control panel, optical keys.	7
Fig. 3: Control panel, disable optical keys.	8
Fig. 4: Control panel, ON/OFF optical keys.	8
Fig. 5: Control panel, Push button operation.	8
Fig. 6: Example of display information during process.	9
Fig. 7: Example of low-battery alarm.	10
Fig. 8: Dimensions – Aluminum / Stainless Steel enclosures.	25
Fig. 9: Installation – Plate mounted	26
Fig. 10: Installation – Pipe mounted	27
Fig. 11: Grounding enclosure	27
Fig. 12: Voltage selection – Sensor supply (P3).	30
Fig. 13: Terminal connectors MEM – standard and options.	31
Fig. 14: Terminal connectors RSM module.	32
Fig. 15: Terminal connections – Passive output R1.	32
Fig. 16: Terminal connections – Mechanical relay output R1.	33
Fig. 17: Terminal connections – Coil signal input.	33
Fig. 18: Terminal connections – NPN signal input.	34
Fig. 19: Terminal connections – PNP signal input.	34
Fig. 20: Terminal connections – Reed-switch signal input.	35
Fig. 21: Terminal connections – NAMUR signal input.	35
Fig. 22: Terminal connections – Active signal input.	36
Fig. 23: Terminal connections – External reset input.	36
Fig. 24: Terminal connectors – Communication connector overview.	37
Fig. 25: Terminal connections – Isolated 4-20mA analog output.	37
Fig. 26: External label Certification Data.	42
Fig. 27: Example external label Thread Sizes.	42
Fig. 28: Example label Main Electronic Module (MEM).	43
Fig. 29: Example Label Basic Supply Module (BSM).	43
Fig. 30: Example Label Relay Supply Module (RSM).	43

## NOTES ABOUT THE E112-P

LIST OF CONFIGURATION SETTINGS			
SETTING	DEFAULT	DATE:	DATE:
<b>1</b>	<b>TOTAL</b>	Enter your settings here	
1.1	UNIT	L	
1.2	DECIMALS	0	
1.3	K-FACTOR	AUTO	
1.4	K-FACTOR DECIMALS	AUTO	
1.5	FACTOR-X	1	
1.6	CLEAR PASSWORD	000	
<b>2</b>	<b>FLOWRATE</b>		
2.1	UNIT	L	
2.2	TIME	/min	
2.3	DECIMALS	0	
2.4	K-FACTOR	AUTO	
2.5	K-FACTOR DECIMALS	AUTO	
2.6	CALCULATION	PLS 10	
2.7	CUT-OFF	30.0	
<b>3</b>	<b>DISPLAY</b>		
3.1	FUNCTION	total	
3.2	LCD NEW	1 sec	
3.3	BACKLIGHT	100%	
3.4	BARGRAPH	enable	
3.5	RATESPAN	1000	
<b>4</b>	<b>FLOWMETER</b>		
4.1	SIGNAL	coil lo	
4.2	UNITS	auto-vol	
4.3	UNIT	L	
4.4	K-FACTOR	1	
4.5	K-FACTOR DECIMALS	0	
<b>5.</b>	<b>LINEARIZE</b>		
5.1	FREQ. / M-FACTOR 1	0.0Hz/1.000000	
5.2	FREQ. / M-FACTOR 2	0.0Hz/1.000000	
5.3	FREQ. / M-FACTOR n	0.0Hz/1.000000	
↑		↑	
5.F	FREQ. / M-FACTOR 15	0.0Hz/1.000000	
5.G	LINEARIZATION		
5.H	DECIMALS FREQUENCY		
<b>6</b>	<b>ANALOG</b>		
6.1	OUTPUT	disable	
6.2	RATE-MIN (4mA)	0	
6.3	RATE-MAX (20mA)	99999	
6.4	CUT-OFF	0.0%	
6.5	TUNE-MIN (4mA)	1438	
6.6	TUNE-MAX (20mA)	5778	
6.7	FILTER	1	
<b>7</b>	<b>PULSE</b>		
7.1	WIDTH	0.000 sec	
7.2	DECIMALS	0	
7.3	AMOUNT	1000	

<b>8</b>	<b>COM MODB</b>			
8.1	SPEED	9600		
8.2	ADDRESS	1		
8.3	MODE	bus-rtu		
8.4	DATABITS	8 bits		
8.5	PARITY	none		

<b>9</b>	<b>DATALOG</b>	(option)		
	<i>For detailed information, refer to the manual E-series – Data logging.</i>			

**For E112-P without data logging**

<b>9</b>	<b>OTHERS</b>			
9.1	MODEL	E112-P		
9.2	SOFTWARE VERSION	03: _ : _		
9.3	SERIAL NO	-----		
9.4	PASSWORD	0000		
9.5	KEY LOCK	enable		
9.6	TAG-NO	0000000		

**For E112-P with data logging**

<b>10</b>	<b>OTHERS</b>			
10.1	MODEL	E112-P		
10.2	SOFTWARE VERSION	03: _ : _		
10.3	SERIAL NO	-----		
10.4	PASSWORD	0000		
10.5	KEY LOCK	enable		
10.6	TAG-NO	0000000		



P.O. box 933

Highway 283 North  
Altus, Oklahoma  
73522 USA

Website: [www.turbinesincorporated.com](http://www.turbinesincorporated.com)

Call toll free: +1-800-809-1387

Document - TU-E112-P-M\_v0102\_13\_EN