

Two-wire Radar Level Transmitter

The Rosemount 5400 Series is a reliable 2-wire radar level transmitter for liquids and slurries, designed for outstanding performance in a wide range of applications and process conditions. It measures level directly and is unaffected by most fluid property changes, including temperature, pressure, vapor gas mixture, density, turbulence, bubbling/boiling, dielectric, pH, viscosity, crystallization, etc.

- *Innovative design. Best-in-class performance*
- *Non-contacting, making it virtually unaffected by process conditions*
- *No moving parts, means little or no maintenance*
- *Application flexibility with full range of antennas, and two models 5402 (26 GHz) and 5401 (6 GHz)*
- *Less affected by coating with Condensation Resistant Antenna*
- *Reduced echoes from obstacles / tank walls with Circular Polarization*
- *Powerful, easy-to-use configuration tool with "Measure-and-Learn" function*



Content

Innovative Measurement Technologies for a Better Bottom Line	page 2
Reliable Measurements through Advanced Surface Tracking Capability	page 5
System Integration	page 6
Transmitter and Antenna Overview	page 8
Measuring Range	page 11
Mechanical Mounting Recommendations	page 12
Specifications	page 15
Product Certifications	page 18
Dimensional Drawings and Mechanical Properties	page 21
Ordering Information	page 28
Application & Configuration Data Sheet	page 34



Rosemount 5400 Series

Innovative Measurement Technologies for a Better Bottom Line

The 5400 Series transmitter is used for level measurements on liquids and slurries with various temperatures, pressures and vapor gas mixtures. Because of its advanced surface tracking capability, the transmitter can detect and evaluate all echoes within the tank.

The Rosemount 5400 Series is easily configured for a wide range of applications and process conditions. In addition, it incorporates advanced signal processing and smart echo tracking features.

MEASUREMENT PRINCIPLE

The distance to the surface is measured by short radar pulses, which are transmitted from the antenna at the tank top.

When a radar pulse reaches a media with a different dielectric constant, part of the energy is reflected back to the transmitter. The time difference between the transmitted and the reflected pulse is proportional to the distance, from which the level, volume and level rate, are calculated.

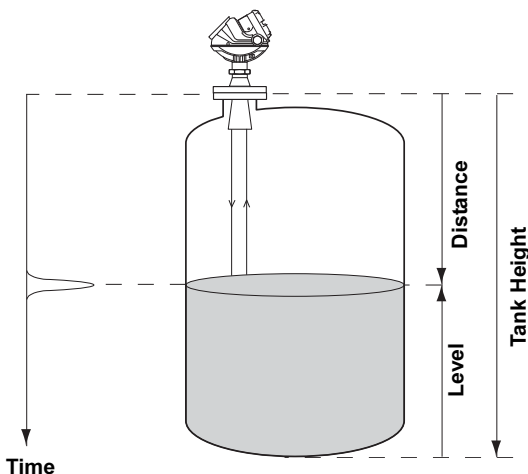

MODELS

The 5400 Series consists of two models:

- Rosemount 5401, Low Frequency Transmitter (~ 6 GHz).
- Rosemount 5402, High Frequency Transmitter (~ 26 GHz).

The availability of two frequencies allows the user to choose the model that best fit the installation and process conditions, with the 5402 being the preferred choice for most applications.

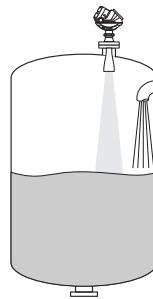

The 5402 transmitter is the preferred choice in most applications because its narrow radar beam offers greater mounting flexibility.

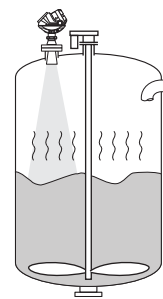

The 5401 transmitter is used in applications with some extreme process conditions.

APPLICATION EXAMPLES FOR THE 5400 SERIES RADAR LEVEL TRANSMITTER

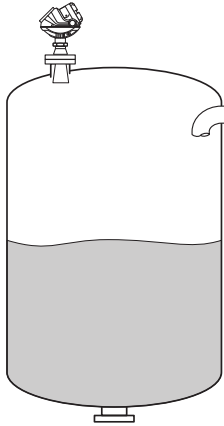

Tanks, vessels, and containers with calm surfaces

Non-contacting radar can also be used in less challenging applications, such as storage and buffer tanks:

- It is easy to mount, maintenance-free, and highly accurate
- Gives precise monitoring and control of the process

Overflow and underfill detection

The 5400 Series can be advantageous in risk reduction systems:

- Continuous measurement may reduce or simplify proof-tests
- Multiple 5400's can be used in the same tank

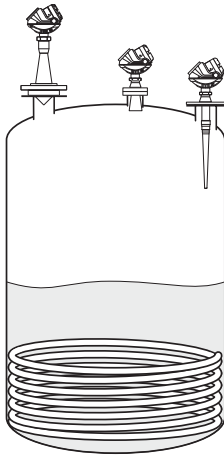

Corrosives

Radar measurement is ideal for most corrosive products, such as caustics, acids, solvents and many other chemicals:

- Not in contact with process product
- Wide material offering such as PTFE, Hastelloy and Monel
- Works well also in non-metallic tanks

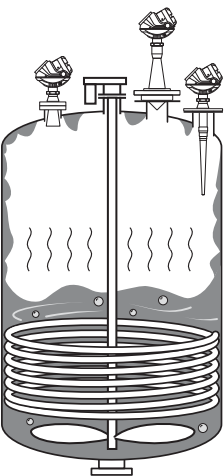

Sticky, viscous and crystallizing products

The best-in-class 5400 Series provides an accurate and reliable level reading with difficult products, such as resins and adhesives:

- Non-contacting is best practice
- Almost unaffected by coating and build-up due to the uniquely designed condensation resistant antennas

Sludges and slurries

Applications like mud, pulp-stock and lime slurries are ideal for non-contacting measurement:

- Immune to splashing and solids content
- Unaffected by density changes
- No re-calibration, no or little maintenance

Rosemount 5400 Series

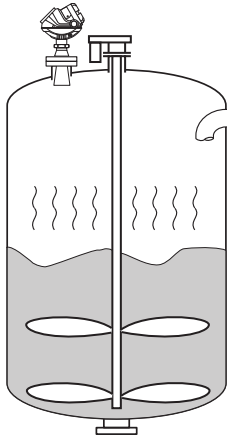

Reactor vessels

The innovative design of the 5400 Series makes it an excellent choice for the most difficult applications, such as reactor vessels:

- Unique circular polarization provides greater mounting flexibility – no clearance distance from tank wall is needed!
- Direct measurement – independent of most variations in process conditions, such as density, dielectric, vapor, temperature and pressure
- Can handle turbulent conditions, whether created by agitation, top-filling or process reaction

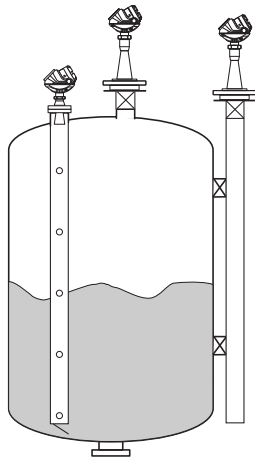

Mounting flexibility

The versatile 5400 Series can be used in mounting configurations other than standard nozzles:

- Fits most existing pipes: 2-8 in.
- Easy to isolate from the process – use a ball-valve

Still-pipes and bridles reduce the influence of foam, turbulence and tank obstructions. Ball-valves can be used on both still-pipes and nozzles.

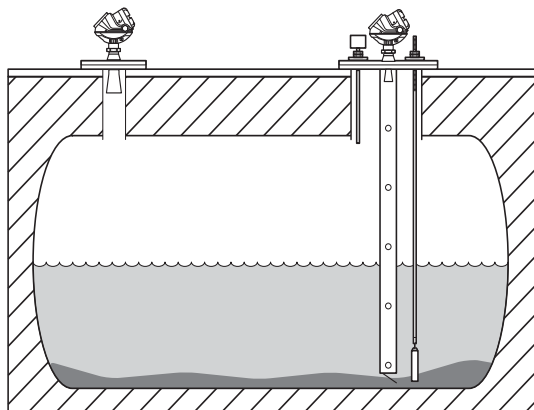

Underground tanks

The mounting flexibility of the 5400 Series makes it an excellent choice for many underground tanks:

- Easy top-mounting
- Can handle long narrow nozzles, and pipes
- Unaffected by dirty products with solids content

For more information on which model and antenna to use for the applications above, see “Transmitter and Antenna Overview” on page 8 and “Measuring Range” on page 11, or contact your local Emerson Process Management representative.

Reliable Measurements through Advanced Surface Tracking Capability

Different process conditions, such as the tank atmosphere, foam, turbulence and products with low dielectric constants, will decrease the returned signal and the radar transmitter may lose track of the surface. It is important that the transmitter can detect very weak signals.

The Rosemount 5400 Series transmitter incorporates several new innovations to provide the best possible surface tracking capability. These features contribute to more reliable measurements and better performance than with standard 2-wire transmitters.

DUAL PORT TECHNOLOGY

Dual Port Technology, two ports for transmitting and receiving signals, reduces noise. Even with a weak returned signal, the transmitter will be able to detect it.

A transmitter with Dual Port Technology can receive 75% less reflected energy than a standard 2-wire transmitter, and still have equal or better surface tracking capability.

Standard 2-wire radar level transmitters only use one port on the microwave generation module for sending and receiving signals, which introduces significant losses in the microwave generation.

CONDENSATION RESISTANT ANTENNA

The tank seal is the part of the waveguide that protects the transmitter from the process atmosphere. Rosemount 5400 Series has a larger protective surface towards the tank, making the transmitter less sensitive to dirt and condensation.

Standard Transmitter

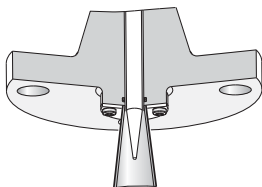

Rosemount 5402

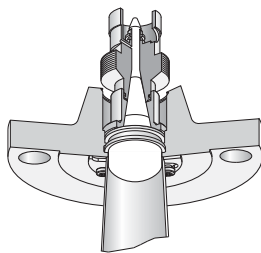

Rosemount 5400 Series transmitters are equipped with an enlarged PTFE tank seal to protect the antenna from contamination and condensation, an especially important feature for high frequency antennas.

CIRCULAR POLARIZATION

Standard radar transmitters utilize linear polarization resulting in greater influence from disturbing objects. The 5400 Series transmitter has circular polarization, which reduces echoes from tank walls and disturbing objects. This means increased installation flexibility and measurement reliability. The transmitter can be installed without any clearance distance to the tank wall.

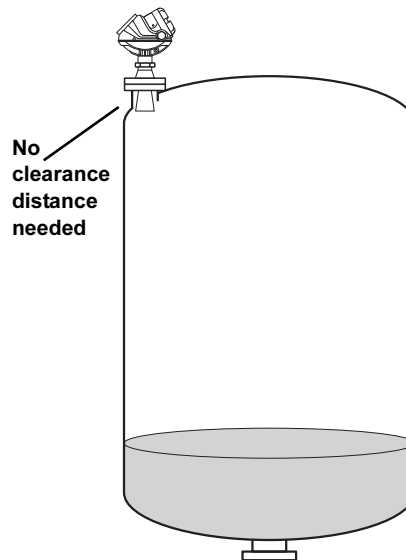

Circular polarization allows the transmitter to be installed without any clearance distance to the tank wall.

Rosemount 5400 Series

System Integration

The Rosemount 5400 Series is a loop-powered device (it uses the same two wires for power supply and communication) that supports both FOUNDATION™ fieldbus, and the analog 4-20 mA with superimposed digital HART®.

EASY INTEGRATION

The 5400 Series supports the latest interoperability standards and can easily be integrated into almost any host system. Rosemount Radar Master, the included software package, can be used to configure the transmitter in five simple steps. Any other DD- (Device Description) or enhanced EDDL-compatible configuration tool such as AMS, DeltaV or the 375 Field Communicator, can also be used.

THE FOUNDATION FIELDBUS ADVANTAGE

No proprietary connections are required for a complete configuration – not even for the echo-curve! This can be done remotely in the control room over the fieldbus segment using Rosemount Radar Master. Basic Configuration can also be performed using any DD-compatible configuration tool, such as DeltaV.

Additionally, with the strength of eleven function blocks and interoperability certificates from all major host system vendors, the 5400 Series will unleash the true benefits of FOUNDATION™ fieldbus.

INNOVATIVE PLANTWEB CAPABILITIES

If the performance of the microwave board starts to degrade, or if the internal temperature sensor gets too hot, a PlantWeb Alert, categorized as a warning, can be displayed to the operator. Alerts describe the problem and recommend actions. Precise diagnostics capabilities like this and many more will simplify troubleshooting and enable predictive maintenance.

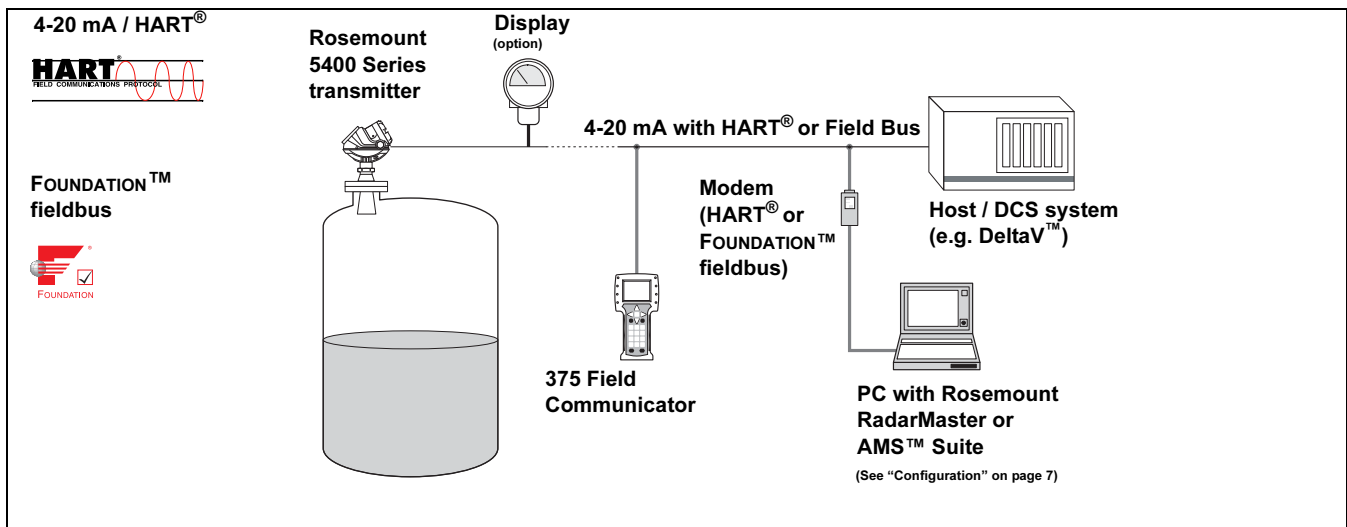

The 5400 Series can be integrated into almost any new or existing plant. Configure it remotely in the control room over the 4-20 mA/Hart® or FOUNDATION™ fieldbus wires. No proprietary connections are needed.

Product Data Sheet

00813-0100-4026, Rev FB

February 2008

Rosemount 5400 Series

DISPLAY

Data can be read from the optional integral display or remotely using the Rosemount 751 Field Signal Indicator (see Product Data Sheet, document number 00813-0100-4378) for 4-20 mA / HART® or the Rosemount 752 Remote Indicator for FOUNDATION™ fieldbus (see Product Data Sheet, document number 00813-0100-4377).

TRANSMITTER VARIABLES

It is possible to receive information about Level, Distance, Volume, Signal Strength, Level Rate, Analog Output Current, % of Range, and Internal Temperature, from one Rosemount 5400 Series radar level transmitter.

CONFIGURATION

Basic configuration can easily be done with Rosemount RadarMaster, a Rosemount 275/375 Handheld Communicator, the AMS™ Suite, DeltaV™ or any other DD compatible host system. For advanced configuration features, RadarMaster is required.

RadarMaster is a user-friendly, Windows based software package that provides easy configuration and service. A wizard guides the user to enter the required parameters for a basic configuration. "Measure & Learn" functionality is accessed through RadarMaster. It enables automatic suggestion of threshold and disturbance echo settings, thereby making tough applications easy to configure. RadarMaster also includes waveform plots, off-line configuration, logging and extensive on-line help.

For 4-20 mA or HART®, a HART® modem is required for communication between the transmitter and RadarMaster (part number 03300-7004-0001 for RS232 and 03300-7004-0002 for USB interface).

For FOUNDATION™ fieldbus devices, RadarMaster is connected to the fieldbus segment via the fieldbus modem (part number 03095-5108-0001 for PCMCIA). For more information, see the 5400 FOUNDATION™ fieldbus Reference Manual (document number 00809-0100-4032) or consult the factory.

Rosemount 5400 transmitters support PlantWeb® Alerts.

It is possible to order a pre-configured transmitter, by filling in the Configuration Data Sheet (CDS).



The integral display is easily configured with Rosemount RadarMaster or the 275/375 Handheld Communicator. The user can choose which variable to display or if toggling between different variables should be applied.

ADVANCED PLANTWEB® FUNCTIONALITY



The Rosemount 5400 Series transmitter powers PlantWeb® through innovative measurement technologies and advanced diagnostics that provide more reliability, easier configuration, reduced process downtime, and lower installation and operating costs for a better bottom line.

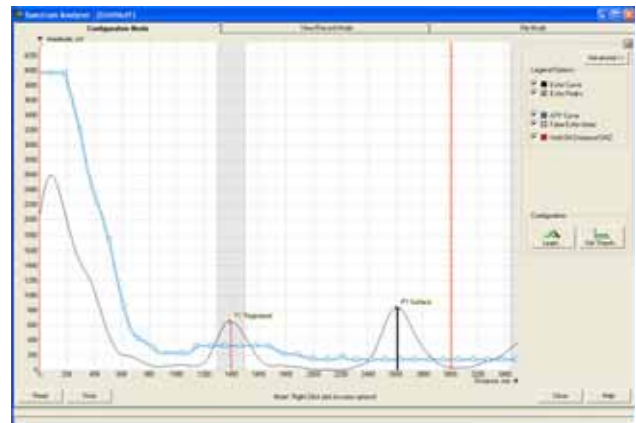

With Rosemount RadarMaster, a noise threshold curve and false echo registration can automatically be created by clicking the Learn button.

Rosemount 5400 Series

Transmitter and Antenna Overview

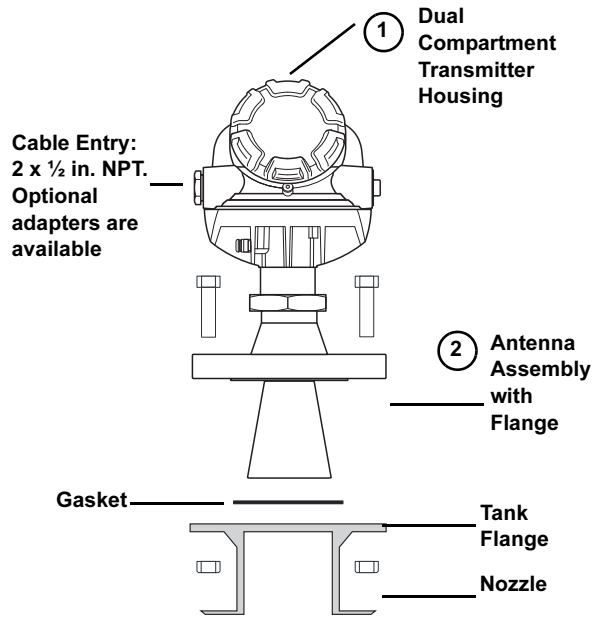

The Rosemount 5400 Series transmitter consists of the transmitter housing and an antenna assembly. The transmitter housing contains all electronics. The antenna assembly seals off the tank atmosphere from the transmitter housing and its surroundings.

The 5400 Series is delivered as a single assembly for easy out-of-box installation, with no special tools.

The transmitter is available with Intrinsically Safe⁽¹⁾ / Non-Incendive or Explosion-proof / Flameproof approvals.

For more information see “Product Certifications.”

TRANSMITTER HOUSING ①

There are two models available with different frequencies: the 5402 (~26 GHz, K-band) and the 5401 (~6 GHz, C-band). The models utilize different frequencies, and antennas, so transmitter housings are not interchangeable.

The transmitter housing has two integral 1/2-in. NPT cable entries for conduit / cable connections. Adapters to other connection types are available, see “Ordering Information” on page 28 and page 28.

The dual-compartment housing separates cabling from the electronics for increased moisture resistance.

The transmitter housing can be rotated and removed from the antenna assembly for service or replacement, without opening the tank.

ANTENNA ASSEMBLY ②

The antenna assembly is the only part in contact with the tank atmosphere, and it consists of an antenna, an O-ring, a tank seal, a flange (see “Standard Flanges” on page 26) or a thread (NPT).

The antenna focuses the radar beam. The Rosemount 5400 Series Radar Level transmitters are equipped with high performance cone, rod and process seal antennas in various sizes and materials.

It is generally recommended that is to use the largest possible antenna be used to achieve highest gain.

For information on temperature and pressure, see “Temperature and Pressure Ratings” on page 17.





(1) *Fisco Intrinsic safety is available for Foundation™ fieldbus. See Ordering Information on page page 28 and 31 for more information on available approvals.*

Product Data Sheet

00813-0100-4026, Rev FB

February 2008

Rosemount 5400 Series

Model and Antenna Guide		5402		5401	
<p>This table gives guidelines on which model and antenna to select, depending on application.</p> <p>G=Good AD=Application Dependent (consult your local Emerson representative) NR=Not Recommended</p>	<p>Cone (preferred)</p> 	<p>Process Seal</p> 	<p>Cone (preferred)</p> 	<p>Rod</p> 	
	<p>Best choice for a broad range of applications, free propagation and pipe installations.</p>	<p>Ideal for small tanks and corrosive applications. Also good for heavy antenna condensation/build-up.</p>	<p>Suitable for some extreme process conditions.</p>	<p>Suitable for small process connections, and corrosive environment.</p>	
Accuracy	± 0.1 in (3 mm)	± 0.1 in (3 mm)	± 0.4 in (10 mm)	± 0.4 in (10 mm)	
Tank Considerations					
Installation close to smooth tank wall	G	G	G	G	
Internal obstructions, directly in path	NR	NR	AD	AD	
Internal obstructions, avoidance ⁽¹⁾	G	G	NR	NR	
Antenna extends below nozzle	G	G	G	G	
Antenna recessed in smooth nozzle up to 6 ft (2 m)	G	G	AD ⁽²⁾	NR ⁽³⁾	
Antenna recessed in nozzle with irregularities, such as bad welds	AD ⁽²⁾	AD	AD ⁽²⁾	NR ⁽³⁾	
Still-pipe mounting	G	G	G	NR	
Valves	G	G	NR	NR	
Pressure/Temperature considerations	See pages page 17, page 21-page 22	See pages page 17 and page 24.	See pages page 17, page 21-page 22	See pages page 17 and page 23.	
Measuring range considerations	See page 11.	See page 11.	See page 11.	See page 11.	
Process Medium Characteristics					
Vapor (light, medium)	G	G	G	G	
Vapor (heavy)	NR	AD	G	G	
Condensing vapor/product build-up ⁽⁴⁾	AD	G	G	AD	
Boiling/Turbulent surface (low/medium)	G	G	G	G	
Boiling/Turbulent surface (heavy)	AD	AD	G ⁽⁵⁾	NR	
Boiling/Turbulent surface (still-pipe)	G	G	G	NR	
Foam ⁽⁶⁾	NR	NR	AD	AD	
Foam (still-pipe) ⁽⁶⁾	G	G	G	NR	
Corrosive products (options available)	G ⁽⁷⁾	G ⁽⁷⁾	G ⁽⁷⁾	G ⁽⁷⁾	
Materials with very low dielectric	G	G	G	AD	
Changing density/dielectric/pH/pressure/temperature	G	G	G	G	
Coating/viscous/crystallizing liquids	G	G	G	G	
Cleanability of antenna	AD	G	AD	G	

(1) The obstruction should not be within the radar beam. Preferred choices due to more narrow radar beam: Model 5402, and cone antenna.
(2) An extended cone antenna can be used.
(3) The active part must protrude beneath the nozzle.
(4) Build-up can often be avoided or reduced by using heat-tracing or cleaning arrangements.
(5) Use a 6 or 8 in. cone antenna.
(6) Foam can either reflect, be invisible or absorb the radar signal. Pipe mounting is advantageous since it reduces the foaming tendency.
(7) See wetted material on page page 10.

Rosemount 5400 Series

	5402 (~ 26 GHz)		5401 (~ 6 GHz)	
Transmitter model and antenna combination	Cone 	Process Seal 	Cone 	Rod 
Wetted Material	Antenna options: <ul style="list-style-type: none"> • 316 / 316 L SST (EN 1.4404) • Hastelloy® C-276 (UNS N10276) • Monel® 400 (UNS N04400) • NACE® Tank Seal: <ul style="list-style-type: none"> • PTFE O-ring⁽²⁾ 	Antenna option: <ul style="list-style-type: none"> • PTFE O-ring⁽²⁾ 	Antenna options: <ul style="list-style-type: none"> • 316 / 316 L SST (EN 1.4404) • Hastelloy® C-276 (UNS N10276) • Monel® • NACE® Tank Seal: <ul style="list-style-type: none"> • PTFE O-ring⁽²⁾ 	Antenna options: <ul style="list-style-type: none"> • PFA⁽¹⁾ • PFA⁽¹⁾ and 316 / 316 L SST (EN 1.4404)⁽²⁾
Process Connection	Flange or Bracket	Flange	Flange or Bracket	Flange, Thread or Bracket

(1) PFA is a fluoropolymer with properties similar to PTFE.

(2) O-ring options: Viton®, Kalrez®, EPDM and Buna-N.

Product Data Sheet

00813-0100-4026, Rev FB

February 2008

Rosemount 5400 Series

Measuring Range

The measuring range depends on the microwave frequency, antenna size, the dielectric constant (ϵ_r) of the liquid, and process conditions. A higher dielectric constant value means a stronger reflection (see the following tables). The figures below are guidelines for optimum performance. Larger measuring ranges may be possible. For more information, contact your local Emerson Process Management office.

- A. Oil, gasoline or other hydrocarbons, and petrochemicals ($\epsilon_r = 1.9-4.0$).
In pipes or with ideal surface conditions, for some liquefied gases ($\epsilon_r = 1.4-4.0$)
- B. Alcohols, concentrated acids, organic solvents, oil/water mixtures, and acetone ($\epsilon_r = 4.0-10.0$).
- C. Conductive liquids, e.g. water based solutions, dilute acids, and alkalis ($\epsilon_r > 10.0$).

Rosemount 5402, Maximum Recommended Measuring Range, ft (m)

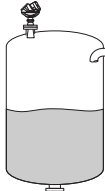
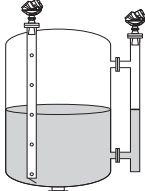
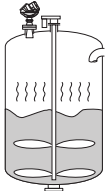
High Frequency Antennas									
	Dielectric Constant								
	A	B	C	A	B	C	A	B	C
2-in. Cone / Process Seal	33 (10)	49 (15)	66 (20)	82 (25)	115 (35)	115 (35)	9.8 (3)	20 (6)	33 (10)
3-in. Cone / Process Seal	49 (15)	66 (20)	98 (30)	82 (25)	115 (35)	115 (35)	13 (4)	30 (9)	39 (12)
4-in. Cone / Process Seal	66 (20)	82 (25)	115 (35)	82 (25)	115 (35)	115 (35)	23 (7)	39 (12)	49 (15)

Rosemount 5401, Maximum Recommended Measuring Range, ft (m)

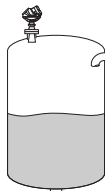
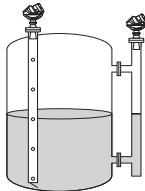
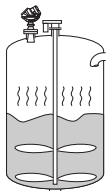
Low Frequency Antennas									
	Dielectric Constant								
	A	B	C	A	B	C	A	B	C
3-in. Cone ⁽¹⁾	NA	NA	NA	82 (25)	115 (35)	115 (35)	NA	NA	NA
4-in. Cone / Rod ⁽²⁾	23 (7)	39 (12)	49 (15)	82 (25)	115 (35)	115 (35)	13 (4)	26 (8)	39 (12)
6-in. Cone	43 (13)	66 (20)	82 (25)	82 (25)	115 (35)	115 (35)	20 (6)	33 (10)	46 (14)
8-in. Cone	66 (20)	82 (25)	115 (35)	82 (25)	115 (35)	115 (35)	26 (8)	39 (12)	52 (16)

(1) Pipe installations only. NA=not applicable.

(2) Pipe installations are not allowed with rod antennas.

Rosemount 5400 Series

Mechanical Mounting Recommendations

MOUNTING LOCATION

For optimal performance, the transmitter should be installed in locations with a clear and unobstructed view of the level surface (A):

- Filling inlets creating turbulence (B), and stationary metallic objects with horizontal surfaces (C) should be kept at a distance, outside the signal beam – see tables on page 14 for beamwidth information
- Agitators with large horizontal blades may reduce the performance of the transmitter, so install the transmitter in a location where this effect is minimized. Vertical or slanted blades are often invisible to radar, but create turbulence (D)
- Do not install the transmitter in the center of the tank (E)
- Because of circular polarization, there is no clearance distance requirement from the tank wall if it is flat and free from obstructions such as heating coils and ladders (F). Usually, the optimal location is 1/3 of the radius from the tank wall

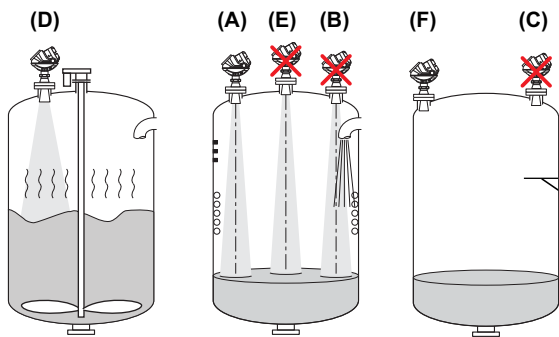

- The antenna is normally aligned vertically
- A metal bridle / still-pipe can be used to avoid disturbing objects, turbulence, and foam (G)

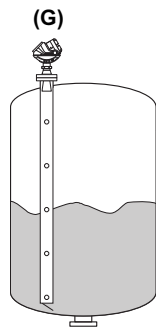

- The walls in non-metallic tanks are invisible to the radar signal, so nearby objects outside the tank may be detected
- Choose the largest possible antenna diameter for installation. A larger antenna concentrates the radar beam, and will be less susceptible to obstruction interference. It also assures maximum antenna gain
- Multiple 5400 transmitters can be used in the same tank without interfering with each other (H)

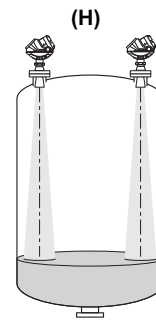

NOZZLE CONSIDERATIONS

Special considerations may have to be taken due to the nozzle, depending on the selection of transmitter model and antenna.

5402 with Cone Antenna

The antenna can be recessed in smooth nozzles up to 6 ft (2 m). If the inside of the nozzle contains disturbing objects, use the extended cone (I).

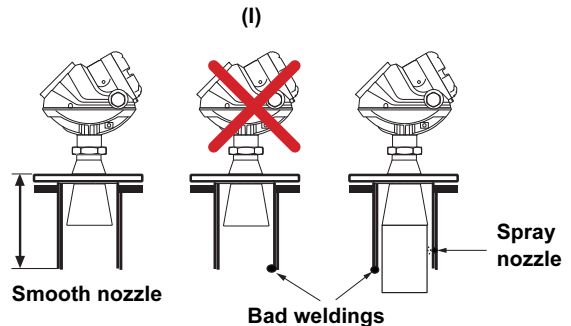

Product Data Sheet

00813-0100-4026, Rev FB

February 2008

Rosemount 5400 Series

5402 with Process Seal Antenna

The antenna can be used on nozzles up to 6 ft (2 m), (J), but disturbing objects inside the nozzle (K) may impact the measurement, and should not be used. The flange on the tank should have a flat or raised face. Other tank flanges may be possible, please consult your local Emerson representative for advice.

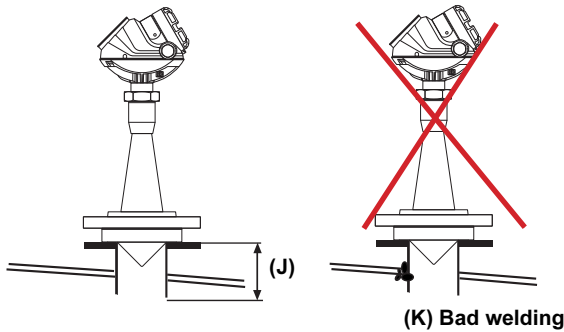

5401 with Cone Antenna

The antenna should extend 0.4 inches (10 mm), or more, below the nozzle (L). If required, use the extended cone solution.

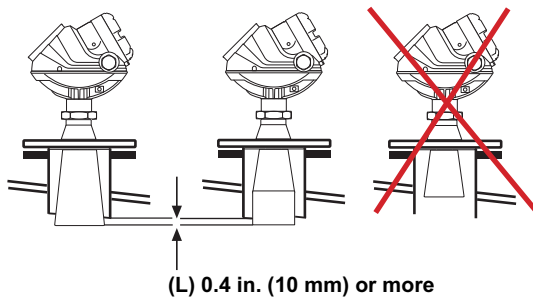

5401 with Rod Antenna

The active part of the rod antenna should be placed under the nozzle (M).

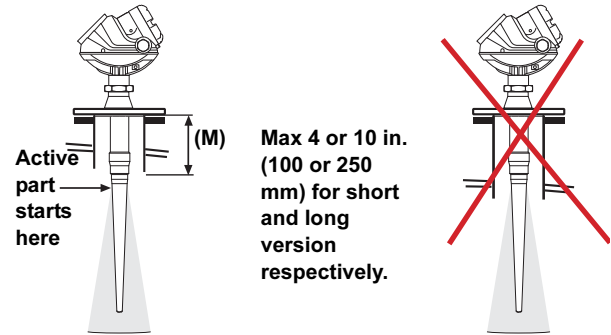

Still-pipes and Bridles in Metallic Materials

If used correctly, pipe measurement can be advantageous in many applications :

- Use cone or process seal antennas – not the rod antenna.
- The gap between the cone antenna and the still-pipe is limited to 0.2 in. (5 mm). If required, order an oversized antenna and cut on location (N).

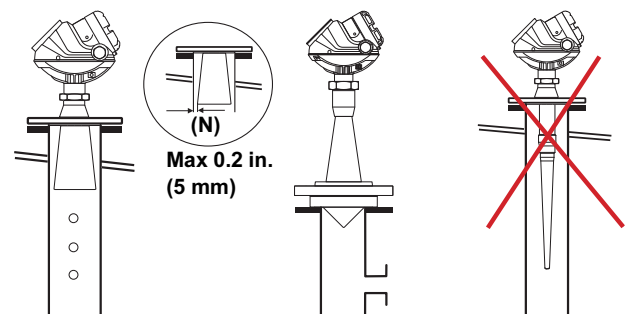

Additional information is available in the Reference Manual (00809-0100-4026), or you can contact your local Emerson representative.

Rosemount 5400 Series

Valves

The 5400 Series transmitter can be isolated from the process by using a valve:

- Use a full-port ball valve
- The 5402 is required, and the Process Seal Antenna is the preferred choice, since it does not require a spool piece. The cone antenna can also be used
- Ensure there is no edge between the ball valve and the nozzle / pipe, the inside should be smooth

Valves can be combined with pipes.

Beam Angle and Beamwidth

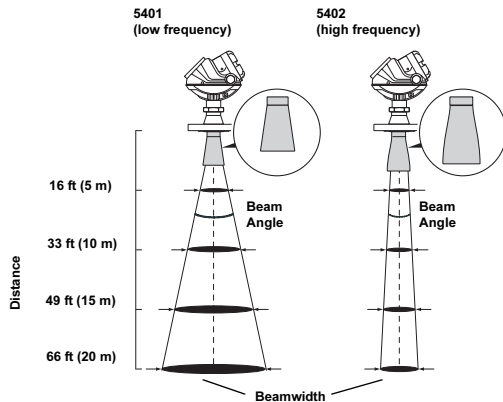

Comparison between the beam angle and beamwidth for the Rosemount 5401 (~6 GHz) and 5402 (~26 GHz) transmitters with antennas of the same size and type.

Beam Angle for Rosemount 5400 Series

Antenna Size	Beam Angle 5402	Beam Angle 5401
2-in. Cone / Process Seal ⁽¹⁾	19°	—
3-in. Cone / Process Seal ⁽¹⁾	14°	(Pipe only)
4-in. Cone / Process Seal ⁽¹⁾ , Rod ⁽²⁾	9°	37°
6-in. Cone	—	23°
8-in. Cone	—	17°

(1) Only with 5402.

(2) Only with 5401.

Beamwidth at different distances from flange for 5402

Distance	Antenna		
	2-in. Cone / Process Seal	3-in. Cone / Process Seal	4-in. Cone / Process Seal
16 ft (5 m)	4.9 (1.5)	3.3 (1.0)	3.3 (1.0)
33 ft (10 m)	9.8 (3.0)	6.6 (2.0)	4.9 (1.5)
49 ft (15 m)	14.8 (4.5)	9.8 (3.0)	8.2 (2.5)
66 ft (20 m)	19.7 (6.0)	13.1 (4.0)	9.8 (3.0)

Beamwidth at different distances from flange for 5401

Distance	Antenna		
	4-in. Cone / Rod	6-in. Cone	8-in. Cone
16 ft (5 m)	11.5 (3.5)	6.6 (2.0)	4.9 (1.5)
33 ft (10 m)	23.0 (7.0)	13.1 (4.0)	9.8 (3.0)
49 ft (15 m)	32.8 (10)	19.7 (6.0)	14.8 (4.5)
66 ft (20 m)	42.7 (13)	26.2 (8.0)	19.7 (6.0)

For more information, see the Reference Manual (document number 00809-0100-4026).

Specifications

General	
Product	Rosemount 5400 Series Radar Level Transmitter
Measurement Principle	Pulsed, free propagating radar 5402: ~26 GHz 5401: ~6 GHz
Microwave Output Power	< 1 mW
Beam Angle	See table on page 12
Re-calibration	Not required due to self-adjusting electronics.
Measuring Performance	
Maximum Measuring Range	115 ft (35 m) from flange
Instrument Accuracy at reference conditions ⁽¹⁾	5402: ± 0.1 in. (± 3 mm) 5401: ± 0.4 in. (± 10 mm)
Repeatability	± 0.04 in. (± 1 mm) at 16.4 ft (5 m) distance
Resolution	0.04 in. (1 mm)
Near Zone Distance	1.3 ft (0.4 m) from lower end of the antenna
Near Zone Accuracy	5402: ± 0.6 in. (± 15 mm) 5401: ± 1.2 in. (± 30 mm)
Transition Zone ⁽²⁾	6 in. (150 mm) from lower end of the antenna
Minimum Dielectric Constant	$\epsilon_r = 1.4$
Temperature Drift	0.05 %/10 K in temperature range -40°F to 176°F (-40°C to 80°C)
Update Interval	1 second
Max Level Rate	1.6 in./s (40 mm/s) as default, adjustable to 7.1 in./s (180 mm/s)
Display / Configuration / Communication	
Integral Display	5-digit integral display. The process variables listed below can be presented. If more than one variable is chosen, carousel toggling of data is used. The display also shows diagnostics and error information.
Output Variables	Level, Distance, Volume, Level Rate, Signal Strength, Internal Temperature, Analog Output Current ⁽³⁾ , and % of Range ⁽³⁾
Output Units	Level and Distance: ft, inch, m, cm or mm Volume: ft ³ , inch ³ , US gals, Imp gals, barrels, yd ³ , m ³ , or liters Level Rate: ft/s, m/s Temperature: °F, °C
Configuration Tools	HART [®] : Rosemount RadarMaster, Rosemount 275/375 Handheld Communicator, AMS Suite or any other EDDL or enhanced-EDDL host FOUNDATION [™] fieldbus: Rosemount RadarMaster, 375 Handheld Communicator, DeltaV [®] or any other DD (Device Description) compatible host system. Certificates of interoperability are available from all major host system vendors.
FOUNDATION [™] fieldbus Blocks	Resource block, 3 Transducer blocks, 6 Analog Input (AI) blocks, Proportional /Integral/Derivate (PID) block, Input Selector (ISEL) block, Signal Characterizer (SGCR) block, Arithmetic (ARTH) block, and Output Splitter (OS) block
FOUNDATION [™] fieldbus Class (Basic or Link Master)	Link Master (LAS)
FOUNDATION [™] fieldbus Block Execution Time	AI-block: 30 ms. PID-block: 40 ms. ARTH-, ISEL-, OSPL-block: 65 ms. CHAR-block: 75 ms
Conforming FOUNDATION [™] fieldbus	ITK 4.6
FOUNDATION [™] fieldbus PlantWeb [®] Alert Support	Yes
Electric	
Terminal Supply Voltage	See "Power Supply" on page 16
Internal Power Consumption	< 50 mW in normal operation
Output	HART [®] 4-20 mA current loop or FOUNDATION [™] fieldbus
Signal on Alarm (configurable), HART [®]	High=21.75 mA (standard setting) Low=3.75 mA (option, model code C8) Namur NE43: High=22.5 mA (option, model code C4)

Rosemount 5400 Series

Electric, continued	
Saturation Levels, HART [®]	Standard: Low=3.9 mA, High=20.8 mA Namur NE43: Low=3.8 mA, High=20.5 mA
IS Parameters	See "Product Certifications" on page 18
Cable Entry	Two integrated ½-in. NPT threads. Adapters are available, see Ordering Information. One metal plug to seal any unused ports is enclosed with the transmitter delivery.
Output Cabling	24-12 AWG, twisted shielded pairs
Quiescent Current Draw (FOUNDATION™ fieldbus)	21 mA
Mechanical	
Antennas	See pages 8, 21, 28 and 28
Material Exposed to Tank Atmosphere	Cone Antenna <ul style="list-style-type: none"> • 316 / 316 L SST (EN 1.4404) or Monel[®] 400 (UNS NO4400) or Hastelloy[®] C-276 (UNS N10276). Monel[®] and Hastelloy[®] antennas have a plate design. • PTFE fluoropolymer • O-ring material. Rod Antenna, Two versions <ul style="list-style-type: none"> • All-PFA⁽⁴⁾ fluoropolymer • PFA⁽⁴⁾ fluoropolymer, 316 / 316 L SST (EN 1.4404) and O-ring material. Process Seal Antenna <ul style="list-style-type: none"> • PTFE fluoropolymer • O-ring material For more information, see pages page 10, page 29 and page 32.
Housing / Enclosure	Polyurethane-covered Aluminum
Dimensions and Weights	See "Dimensional Drawings and Mechanical Properties" on page 21
Environment	
Ambient Temperature ⁽⁵⁾	-40°F to 176°F (-40°C to 80°C). LCD readable in: -4°F to 158°F (-20°C to 70°C).
Storage Temperature	-58°F to 194°F (-50°C to 90°C). LCD: -40°F to 185°F (-40°C to 85°C)
Flange Temperature	See "Temperature and Pressure Ratings" on page 17
Process Pressure	See "Temperature and Pressure Ratings" on page 17
Humidity	0 - 100% Relative Humidity, non condensating
Factory Sealed	Yes
Ingress Protection	Type 4X, IP66, IP67
EU Directive compliance	CE mark, 93/68/EEC
Radio Approvals ⁽⁶⁾⁽⁷⁾	FCC part 15C (1998) ⁽⁸⁾ , R&TTE (EU directive 1999/5/EC), and IC (RSS210-5)
Electromagnetic Compatibility ⁽⁹⁾	Emission and Immunity: EMC directive 89/336/EEC. EN61326-1:1997 incl. A1:1998 and A2:2001. NAMUR recommendations NE21.
Transient / Built-in Lightning Protection ⁽⁹⁾	EN61326, IEC 801-5, level 1 kV. T1 option: Additionally, the transmitter complies with IEEE 587 Category B transient protection and IEEE 472 surge protection. The protection includes gas-filled discharge tubes and semiconductor components.
Pressure Equipment Directive (PED)	97/23/EC
Vibration Resistance ⁽⁹⁾	IEC 60770-1 level 1
<p>(1) <i>Ideal metal plate with no disturbing objects.</i> Temperature: + 68 °F (20 °C). Pressure: 14-15 psi (960-1060 mbar). Humidity: 25-75 % RH.</p> <p>(2) <i>Transition Zones are areas where measurements are not recommended.</i></p> <p>(3) <i>Not applicable for FOUNDATION™ fieldbus.</i></p> <p>(4) <i>PFA is a fluoropolymer with properties similar to PTFE.</i></p> <p>(5) <i>Temperature may be limited by the selected product certificate, see "Product Certifications" on page 18.</i></p> <p>(6) <i>Only a limited selection is presented. Contact your local Emerson representative for more information.</i></p> <p>(7) <i>For Japan: "Install device on tanks or pipes made of metal".</i></p> <p>(8) <i>For 5402: "This device is authorized for use in tank-mounted applications, including metal tanks as well as concrete, plastic, glass and other non-conductive tanks." No specific restrictions are stated for the 5401.</i></p> <p>(9) <i>The device may also comply with other standards. Consult your local Emerson representative.</i></p>	

POWER SUPPLY

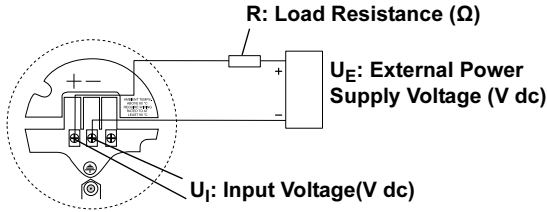

4-20 mA with HART[®] communication



The input voltage U_I for HART[®] is 16-42.4 V dc (16-30 V dc in IS applications, and 20-42.4 V dc in Explosion-proof / Flameproof applications). Maximum load resistance and power supply limitations for typical operating conditions are given in the diagrams and table below.

Non-Hazardous Installations

R(Ω) Maximum Load Resistance

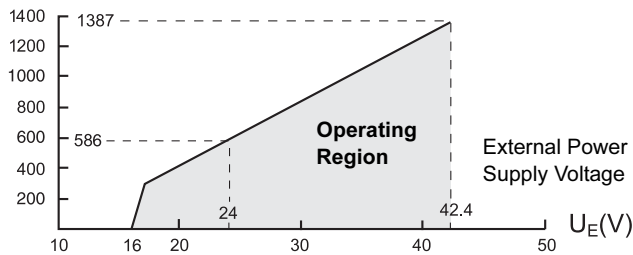

Intrinsically Safe Installations

R(Ω) Maximum Load Resistance

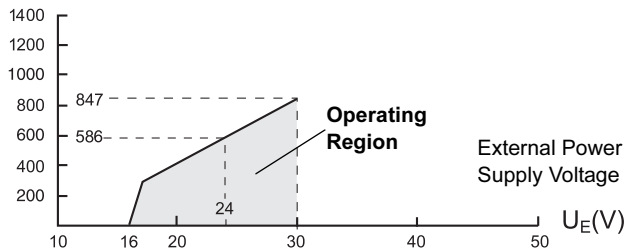

Explosion-proof / Flameproof Installations

R(Ω) Maximum Load Resistance

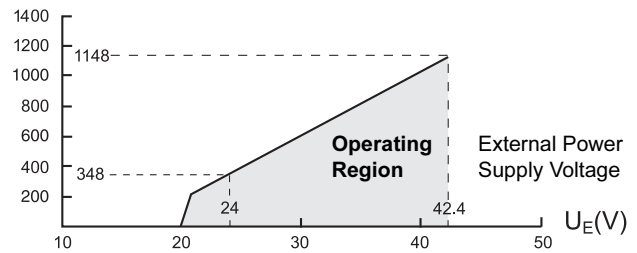

NOTE

The diagram is only valid if the HART[®] load resistance is at the + side and if the - side is grounded, otherwise the load resistance value is limited to 435 Ohm.

Minimum input voltage (U_I) at different currents

Hazardous approval	Current	
	3.75 mA	21.75 mA
Non-Hazardous Installations and Intrinsically Safe Installations	16 V dc	11 V dc
Explosion-proof / Flameproof Installations	20 V dc	15.5 V dc

FOUNDATION[™] fieldbus



The input voltage U_I for FOUNDATION[™] fieldbus is 9-32 V dc (9-30 V dc in IS applications, 9-17.5 V dc in FISCO applications, and 16-32 V dc in Explosion-proof / Flameproof applications). The quiescent current draw is 21 mA.

Rosemount 5400 Series

TEMPERATURE AND PRESSURE RATINGS

Flange Temperature

The temperature at the flange is limited by the antenna, the tank seal, and O-rings (if applicable). The continuous flange temperature range is presented for each antenna in section “Dimensional Drawings and Mechanical Properties” on page 21.

Electronics Temperature

There are restrictions on the ambient temperature (see Specifications on page page 16), and the ambient temperature may also be limited by the selected product certificate (see “Product Certifications” on page 18).

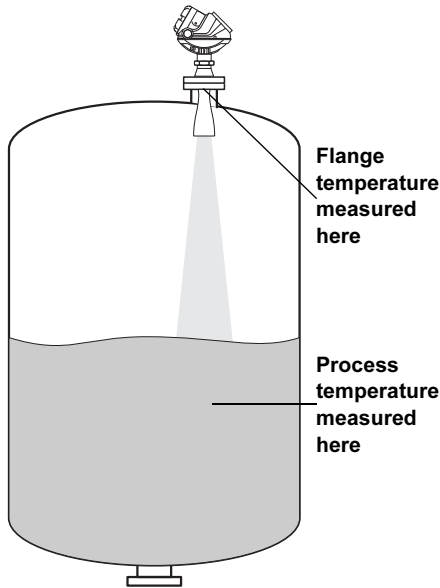

Temperature rating considerations.

NOTE

Flange temperature depends on process and ambient temperature, and mounting conditions such as nozzle position, distance to max product level, nozzle height, presence of insulation, etc.

Operating Pressure

The pressure in the tank is limited by a combination of the antenna and the process connection.

The following 5400 Series flanges have the same p/T rating as the corresponding blind flanges:

ANSI: according to ANSI B16.5 Table 2-2.3.

EN: according to EN 1092-1 Table 18, material group 13E0.

The continuous operating pressure range is presented for each antenna in section “Dimensional Drawings and Mechanical Properties” on page 21.

Product Data Sheet

00813-0100-4026, Rev FB

February 2008

Rosemount 5400 Series

Product Certifications

SAFETY NOTE AND SPECIAL CONDITIONS FOR SAFE USE (X-MARKING IN ATEX, IECEx, AND NEPSI CERTIFICATES)

The intrinsically safe circuits do not withstand the 500 V ac test as specified in EN 50020 clause 6.4.12.

Parts of the rod antenna and the process seal antenna are non-conducting and the area of the non-conducting part exceeds the maximum permissible areas for Group IIC according to EN 50014, clause 7.3 (20 cm²) and Category II 1G according to EN 50284, clause 4.4.3 (4 cm²) (20 cm² for zone 1 and 4 cm² for zone 0 according to IEC 60079-0, clause 7.3). Therefore, when the antenna is used in a potentially explosive atmosphere, appropriate measures must be taken to prevent electrostatic discharge.

Impact and friction hazards need to be considered according to EN 50284, clause 4.3.1 (IEC 60079-0, clause 8.1.2) when the transmitter and part of antennas exposed to the exterior atmosphere of the tank is made of light metal alloys, and used in Category II 1 G (zone 0).

ATEX Approvals Nemko 04ATEX1073X

E1⁽¹⁾ Flameproof:

 II 1/2 GD T73°C⁽²⁾.
EEx iad IIC T4 (-40°C < T_a < +70°C⁽³⁾).
U_m=250 V

I1⁽¹⁾ Intrinsically Safe:

 II 1 GD T73°C⁽²⁾.
EEx ia IIC T4 (-50°C < T_a < +70°C⁽³⁾).
4-20 mA / HART[®] model: U_i=30 V dc, I_i=130 mA, P_i=1.0 W,
C_i=7.26 nF, L_i=0 H.
FOUNDATION[™] fieldbus model: U_i=30 V dc, I_i=300 mA,
P_i=1.5 W, C_i=0 nF, L_i=0 H.
FISCO model: U_i=17.5 V dc, I_i=380 mA, P_i=5.32 W, L_i=C_i=0.
Installation Drawing: 9150079-907.

(1) Ordering Information code for Product Certificates, see page 31.

(2) +63°C with FOUNDATION[™] fieldbus or FISCO option.

(3) +60°C with FOUNDATION[™] fieldbus or FISCO option.

National Supervision and Inspection Center for Explosion Protection and Safety of Instrumentation (NEPSI) Approvals GYJ06242X, GYJ06458X

E3⁽¹⁾ Flameproof:

Ex iad IIC T4 (-40°C < T_a < +70°C⁽³⁾).
U_m=250 V

I3⁽¹⁾ Intrinsically Safe:

Ex ia IIC T4 (-40°C < T_a < +70°C⁽³⁾).
4-20 mA / HART[®] model: U_i=30 V dc, I_i=130 mA, P_i=1.0 W,
C_i=7.26 nF, L_i=0 H.
FOUNDATION[™] fieldbus model: U_i=30 V dc, I_i=300 mA,
P_i=1.5 W, C_i=0 nF, L_i=0 H.
FISCO model: U_i=17.5 V dc, I_i=380 mA, P_i=5.32 W, L_i=C_i=0.
Installation Drawing: 9150079-907.

Technology Institution of Industrial Safety (TIIS) Approval

E4⁽¹⁾ Flameproof:

Transmitter: Ex d [ia] IIC T4
Antenna: Ex ia IIC T4
Installation Drawing: 05400-00375A.

Factory Mutual (FM) Approvals

Project ID: 3020497

E5⁽¹⁾ Explosion-Proof for Class I, Div. 1,
Groups B, C and D;
Dust Ignition Proof for Class II/III, Div. 1, Groups E, F and G;
With Intrinsically Safe connections to
Class I, II, III, Div. 1, Groups B, C, D, E, F and G.
Temp. Code T4
Ambient temperature limits: -40°C to +70°C⁽³⁾.
Seal not required.

I5⁽¹⁾ Intrinsically Safe for Class I, II, III, Div. 1, Groups A, B, C, D,
E, F and G,
Class I, Zone 0, AEx ia IIC T4 when installed per Control
Drawing: 9150079-905.

Non-Incendive Class I, Div. 2, Groups A, B, C and D;
Suitable for Class II, III, Div. 2, Groups F and G.

4-20 mA / HART[®] model: U_i=30 V dc, I_i=130 mA, P_i=1.0 W,
C_i=7.26 nF, L_i=0 H.

FOUNDATION[™] fieldbus model: U_i=30 V dc, I_i=300 mA,
P_i=1.3 W, C_i=0 nF, L_i=0 H.

FISCO model: U_i=17.5 V dc, I_i=380 mA, P_i=5.32 W, L_i=C_i=0.

Max operation:

4-20 mA / HART[®] model: 42.4 V, 25 mA,
FOUNDATION[™] fieldbus model: 32 V, 25 mA.

Temp. Code T4

Ambient temperature limits: -40°C to +70°C⁽³⁾.

Rosemount 5400 Series

Canadian Standards Association (CSA) Approvals

Project ID: 1514653

E6⁽¹⁾ Explosion-proof with internal Intrinsically Safe Circuits [Exia]
Class I, Div. 1, Groups B, C and D;
Temp Code T4.
Class II, Div. 1 and 2, Groups E, F and G;
Class III, Div. 1
Ambient temperature limits -40°C to +70°C⁽²⁾
Factory sealed.

I6⁽¹⁾ Intrinsically Safe Exia:
Class I, Div. 1, Groups A, B, C and D.
Temp Code T4.
4-20 mA / HART[®] model: $U_i=30$ V dc, $I_i=130$ mA, $P_i=1.0$ W,
 $C_i=7.3$ nF, $L_i=0$ H.
FOUNDATION[™] fieldbus model: $U_i=30$ V dc, $I_i=300$ mA,
 $P_i=1.3$ W, $C_i=0$ nF, $L_i=0$ H.
FISCO model: $U_i=17.5$ V dc, $I_i=380$ mA, $P_i=5.32$ W, $L_i=C_i=0$.
Installation Drawing: 9150079-906
Ambient temperature limits -40°C to +70°C⁽²⁾.

IECEX Approval

IECEX NEM 06.0001x

E7⁽¹⁾ Flameproof:
Ex iad IIC T4 (-40°C < T_a < +70°C⁽²⁾).
 $U_m=250$ V

I7⁽¹⁾ Intrinsically Safe:
Ex ia IIC T4 (-50°C < T_a < +70°C⁽²⁾).
4-20 mA / HART[®] model: $U_i=30$ V dc, $I_i=130$ mA, $P_i=1.0$ W,
 $C_i=7.26$ nF, $L_i=0$ H.
FOUNDATION[™] fieldbus model: $U_i=30$ V dc, $I_i=300$ mA,
 $P_i=1.5$ W, $C_i=0$ nF, $L_i=0$ H.
FISCO model: $U_i=17.5$ V dc, $I_i=380$ mA, $P_i=5.32$ W, $L_i=C_i=0$.
Installation Drawing: 9150079-907.

For more information on product certificates, refer to the Reference Manual (document number 00809-0100-4026).

(1) Ordering Information code for Product Certificates, see page 31.

(2) +60°C with FOUNDATION[™] fieldbus or FISCO option.

Dimensional Drawings and Mechanical Properties

ROSEMOUNT 5402 AND 5401 WITH SST CONE ANTENNA (MODEL CODE 2S-8S)

All dimensions are in inches (mm).

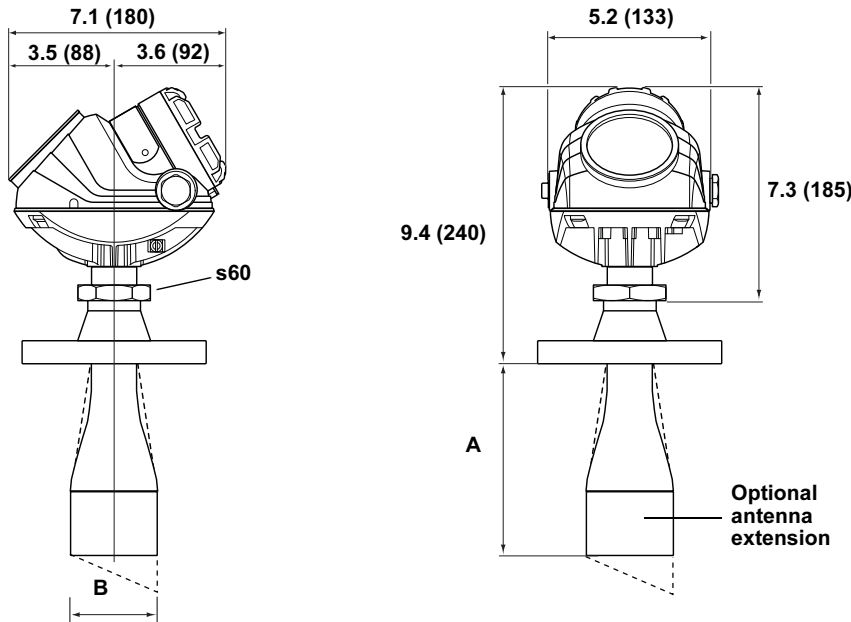

Process Connection Availability

- Available as standard
- Available as special, consult factory
- Not available

Process Connection	Antenna Code	
	2S	3S, 4S, 6S, 8S
2 in. / DN 50 / 50A	●	○
3 in. / DN 80 / 80A	●	●
4 in. / DN 100 / 100A	●	●
6 in. / DN 150 / 150A	●	●
8 in. / DN 200 / 200A	●	●
Threaded Connection	–	–
Bracket Mounting	●	●

5402 Standard SST Cone

Cone size (inches)	A	B	Antenna Code
2	6.5 (165)	2.0 (50)	2S
3	5.9 (150)	2.6 (67)	3S
4	8.8 (225)	3.6 (92)	4S

5401 Standard SST Cone

Cone size (inches)	A	B	Antenna Code
3	3.3 (84)	2.6 (67)	3S
4	5.9 (150)	3.6 (92)	4S
6	7.3 (185)	5.5 (140)	6S
8	10.6 (270)	7.4 (188)	8S

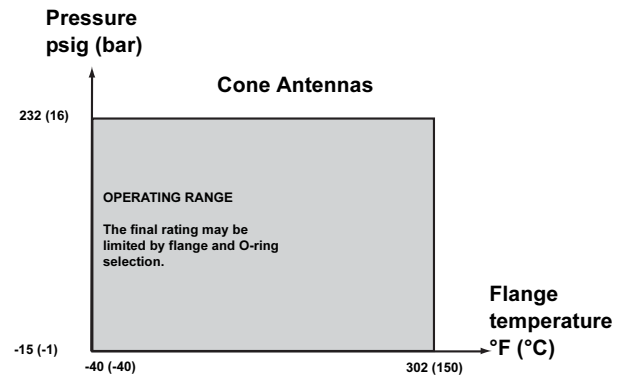

Process temperature and pressure diagram.

5402 and 5401 Extended SST Cone⁽¹⁾

Max. nozzle height	A	Option Code
20 (500)	20.4 (518)	S3

(1) The extended cone antennas are available in 5-inch step increments from 10 to 50 inches. Consult your local Emerson Process Management representative for more information. Expect long lead times for other sizes than the 20 in. (500 mm) version.

Temperature restrictions due to O-ring selection.

Tank seal with different O-ring materials	Min. Temperature °F (°C) in air	Max. Temperature °F (°C) in air
Viton®	-4 (-20)	302 (150)
Ethylene Propylene (EPDM)	-40 (-40)	302 (150)
Kalrez® 6375	5 (-15)	302 (150)
Buna-N	-40 (-40)	230 (110)

Rosemount 5400 Series

ROSEMOUNT 5402 AND 5401 WITH WETTED FLANGE PLATE CONE ANTENNA (MODEL CODE: 2H-8H, 2M-8M AND 2N-8N)

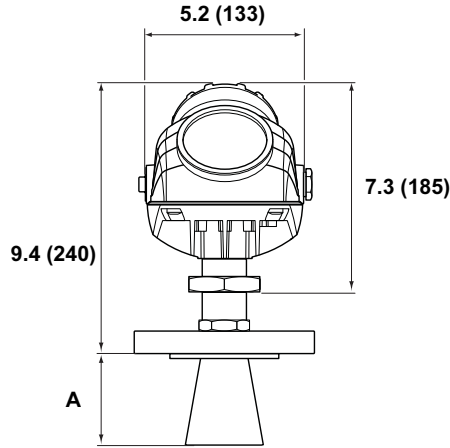
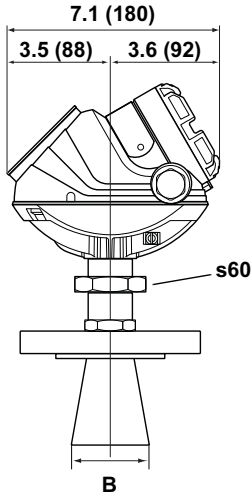

All dimensions are in inches (mm).

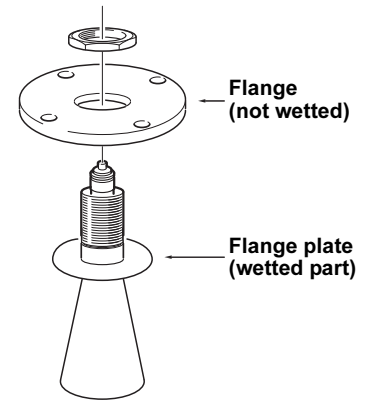

5402 Cone Antenna With Wetted Flange Plate

Cone size (inches)	A	B	Antenna Code
2	5.9 (150)	2.0 (50)	2H, 2M, 2N
3	6.9 (175)	2.6 (67)	3H, 3M, 3N
4	9.8 (250)	3.6 (92)	4H, 4M, 4N

5401 Cone Antenna With Wetted Flange Plate

Cone size (inches)	A	B	Antenna Code
3	3.3 (84)	2.6 (67)	3H, 3M, 3N
4	5.9 (150)	3.6 (92)	4H, 4M, 4N
6	7.3 (185)	5.5 (140)	6H, 6M, 6N
8	10.6 (270)	7.4 (188)	8H, 8M, 8N

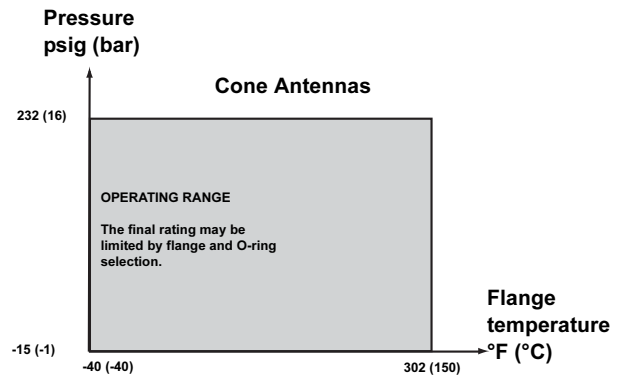

Process temperature and pressure diagram.

Process Connection Availability

- Available as standard
- Available as special, consult factory
- Not available

Process Connection	Antenna Code				
	2H, 2M, 2N	3H, 3M, 3N	4H, 4M, 4N	6H, 6M, 6N	8H, 8M, 8N
2 in. / DN 50 / 50A	●	○	○	○	○
3 in. / DN 80 / 80A	○	●	○	○	○
4 in. / DN 100 / 100A	○	○	●	○	○
6 in. / DN 150 / 150A	○	○	○	●	○
8 in. / DN 200 / 200A	○	○	○	○	●
Threaded Connection	-	-	-	-	-
Bracket Mounting	-	-	-	-	-

Temperature restrictions due to O-ring selection.

Tank seal with different O-ring materials	Min. Temperature °F (°C) in air	Max. Temperature °F (°C) in air
Viton®	-4 (-20)	302 (150)
Ethylene Propylene (EPDM)	-40 (-40)	302 (150)
Kalrez® 6375	5 (-15)	302 (150)
Buna-N	-40 (-40)	230 (110)

Drawing: 9240030-973 (www.rosemount.com)

ROSEMOUNT 5401 WITH ROD ANTENNA (MODEL CODE 1R-4R)

All dimensions are in inches (mm).

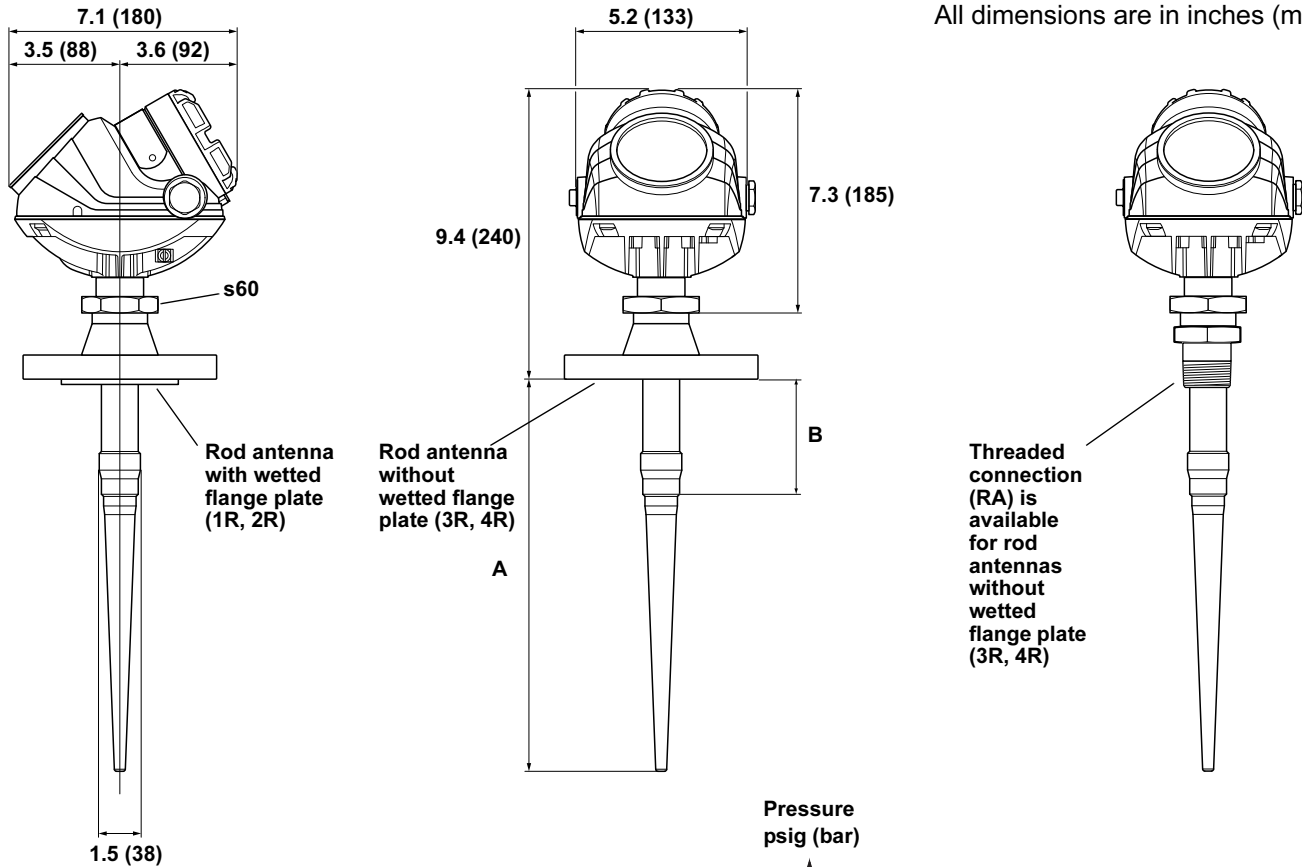

Rod	A	B ⁽¹⁾	Antenna Code
Short	14.4 (365)	4 (100)	1R, 3R
Long	20.3 (515)	10 (250)	2R, 4R

(1) The active part of the antenna must protrude into the tank. B is the maximum nozzle height.

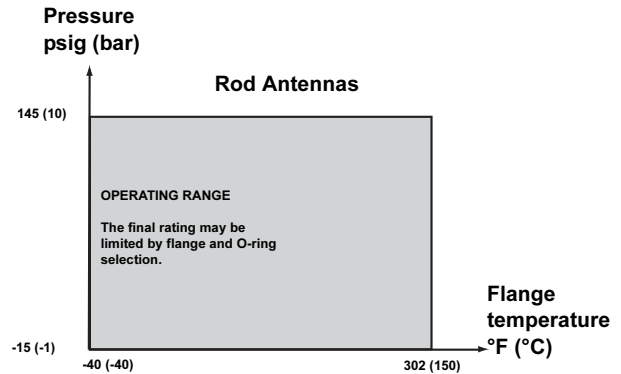

Process temperature and pressure diagram.

Process Connection Availability

- Available as standard
- Available as special, consult factory
- Not available

Process Connection	Antenna Code	
	1R, 2R	3R, 4R
2 in. / DN 50 / 50A	●	●
3 in. / DN 80 / 80A	●	●
4 in. / DN 100 / 100A	●	●
6 in. / DN 150 / 150A	○	●
8 in. / DN 200 / 200A	○	●
Threaded Connection	–	●
Bracket Mounting	–	●

Temperature restrictions due to O-ring selection (not applicable for 1R and 2R where no process O-ring is present).

Tank seal with different O-ring materials	Min. Temperature °F (°C) in air	Max. Temperature °F (°C) in air
Viton®	-4 (-20)	302 (150)
Ethylene Propylene (EPDM)	-40 (-40)	302 (150)
Kalrez® 6375	5 (-15)	302 (150)
Buna-N	-40 (-40)	230 (110)

Rosemount 5400 Series

ROSEMOUNT 5402 WITH PROCESS SEAL ANTENNA (MODEL CODE 2P-4P)

All dimensions are in inches (mm).

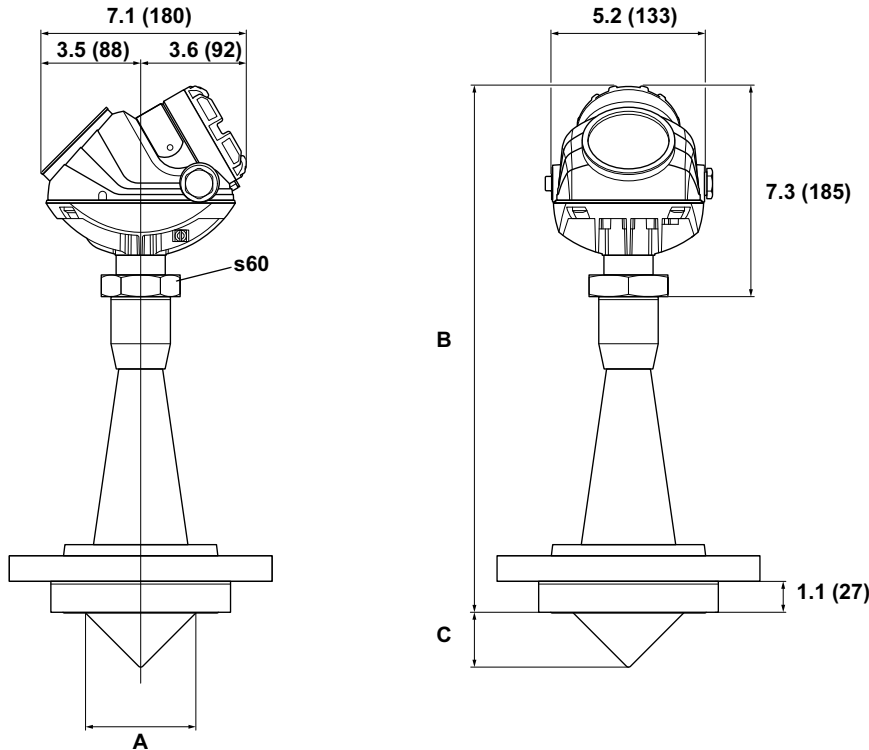

Process Seal size (inches)	A	B	C	Antenna Code
2	1.8 (46)	14.2 (360)	0.9 (22)	2P
3	2.8 (72)	17.3 (440)	1.4 (35)	3P
4	3.8 (97)	18.9 (480)	1.9 (48)	4P

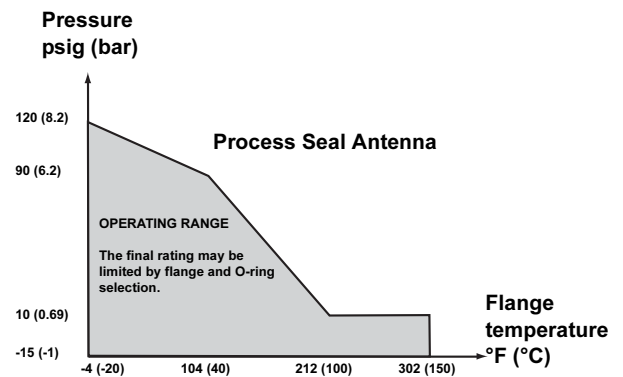

Process temperature and pressure diagram.

Process Connection Availability

- Available as standard
- Available as special, consult factory
- Not available

Process Connection	Antenna Code		
	2P	3P	4P
2 in. / DN 50 / 50A	●	-	-
3 in. / DN 80 / 80A	-	●	-
4 in. / DN 100 / 100A	-	-	●
6 in. / DN 150 / 150A	-	-	-
8 in. / DN 200 / 200A	-	-	-
Threaded Connection	-	-	-
Bracket Mounting	-	-	-

Temperature restrictions due to O-ring selection.

Tank seal with different O-ring materials	Min. Temperature °F (°C) in air	Max. Temperature °F (°C) in air
Viton®	-4 (-20)	302 (150)
Ethylene Propylene (EPDM)	-4 (-20)	275 (135)
Kalrez® 6375	23 (-5)	302 (150)
Buna-N	-4 (-20)	257 (125)

Drawing: 9240030-976 (www.rosemount.com)

Product Data Sheet

00813-0100-4026, Rev FB

February 2008

Rosemount 5400 Series

PROCESS CONNECTIONS

Bracket Mounting (model code BR)

Bracket mounting is available for Rosemount 5401 and 5402 with SST Cone Antenna (2S-8S) and Rosemount 5401 with Rod Antenna (3R-4R)

All dimensions are in inches (mm).

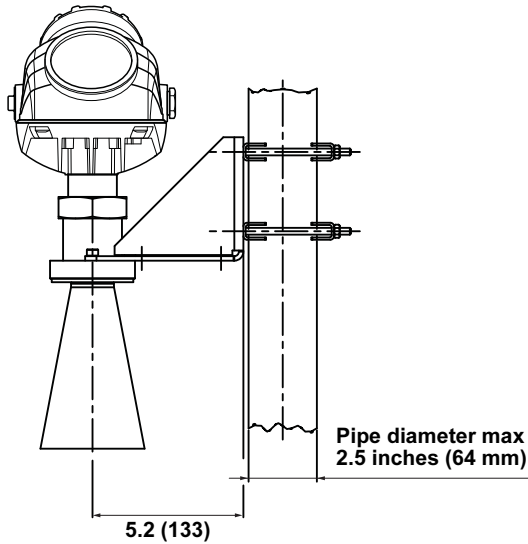

**Pipe mounting
(vertical pipe)**

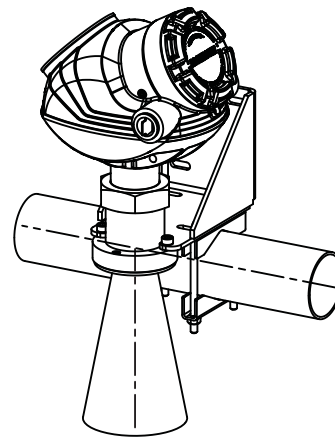

**Pipe mounting
(horizontal pipe)**

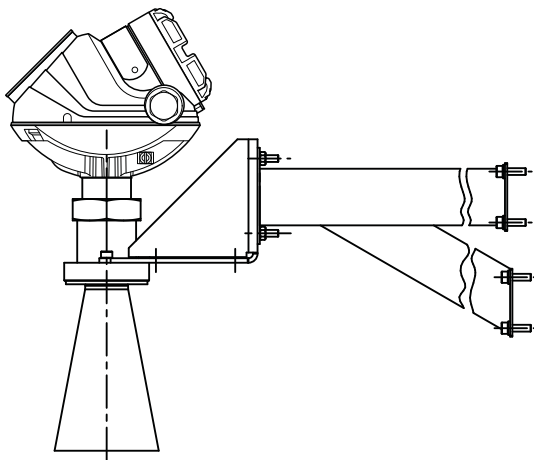

Wall mounting

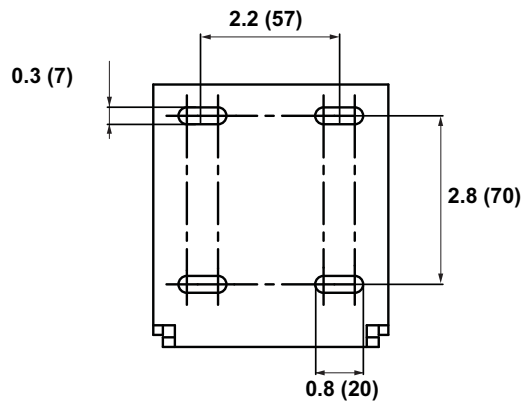

**Hole pattern
wall mounting**

Drawing: 9240030-989 (www.rosemount.com)

Rosemount 5400 Series

Standard Flanges

Cone and Rod Antennas (model code: 2S-8S and 1R-4R)

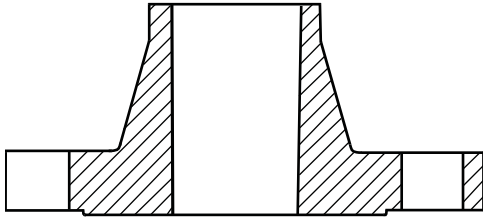

Designation	Mating Standard	Face Style ⁽¹⁾	Face Surface Finish	Material
ANSI	ASME B16.5	0.06 in. Raised Face	$R_a = 125-250 \mu\text{in.}$	316 / 316L
EN (DIN)	EN 1092-1	2 mm Raised Face (Type B1)	$R_a = 3.2-12.5 \mu\text{m.}$	EN 1.4404
JIS	JIS B2220	2 mm Raised Face	$R_a = 3.2-6.3 \mu\text{m}$	EN 1.4404

⁽¹⁾ Face gasket surface is serrated per mating standard.

Cone Antennas with Wetted Flange Plate (model code: 2H-8H, 2M-8M, and 2N-8N)

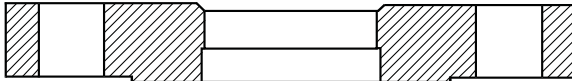

Designation	Mating Standard	Face Style ⁽¹⁾	Face Surface Finish	Material
ANSI	ASME B16.5	0.06 in. Raised Face	$R_a = 125-250 \mu\text{in.}$	316 / 316L
EN (DIN)	EN 1092-1	Flat Face (Type A)	$R_a = 3.2-12.5 \mu\text{m.}$	EN 1.4404
JIS	JIS B2220	2 mm Raised Face	$R_a = 3.2-6.3 \mu\text{m}$	EN 1.4404

⁽¹⁾ Face gasket surface is serrated per mating standard.

Process Seal Antennas



Designation	Standard	Style	Material
ANSI	ASME B16.5	Slip-on	316 / 316L
EN (DIN)	EN 1092-1	Slip-on (Type 01)	EN 1.4404
JIS	JIS B2220	Slip-on plate (SOP)	EN 1.4404

Product Data Sheet

00813-0100-4026, Rev FB

February 2008

Rosemount 5400 Series

APPROXIMATE WEIGHTS

Transmitter	Weight lbs (kg)
Aluminium housing	4.4 lbs (2.0 kg)
Antenna (Model Code)	Add max lbs (kg)
Cone Antenna (2S-8S, 2H-8H, 2M-8M, 2N-8N)	2.2 lbs (1.0 kg)
Process Seal Antenna (2P-4P)	4.4 lbs (2.0 kg)
Rod Antenna (1R-4R)	2.2 lbs (1.0 kg)
Process Connection (Model Code)⁽¹⁾	Add max lbs (kg)
ANSI Flange, 2 in. 150 lbs SST (AA)	6.6 lbs (3.0 kg)
EN (DIN) Flange, DN50 PN40 SST (HB)	8.8 lbs (4.0 kg)
JIS Flange 50A 10K SST (UA)	6.6 lbs (3.0 kg)
Bracket Mounting (BR)	4.4 lbs (2.0 kg)
Thread Adapter (RA)	1.1 lbs (0.5 kg)

- (1) Approximate weights for other 5400 Series process connection sizes than those in this table can be estimated:
First of all, find out the weight of the SST blind flange (slip-on for process seal antennas) that corresponds to the type and size shown in this table.
Find out the weight for the SST blind flange that corresponds to the specific 5400 Series flange size which is not represented in this table.
The 5400 Series flange weight can be estimated by adding the relative weight difference of these SST blind flanges.

Rosemount 5400 Series

Ordering Information

Model Code for Rosemount 5402 Radar Level Transmitter

Model	Product Description
5402	High frequency version (~26 GHz)
Code	Housing Material
A	Polyurethane-covered Aluminum
Code	Signal Output
H	4-20 mA with HART [®] communication
F	FOUNDATION [™] fieldbus
Code	Conduit / Cable Threads
1	1/2 inch - 14 NPT
2	M20 x 1.5 adapter
E	M12, 4-pin, Male Connector (eurofast [®])(1)
M	A size Mini, 4-pin, Male Connector (minifast [®])(1)
Code	Product Certifications
NA	No Product Certificates
E1	ATEX Flameproof ⁽¹⁾
I1	ATEX Intrinsic Safety
IA	ATEX FISCO Intrinsic Safety ⁽²⁾
E3	NEPSI Flameproof ⁽¹⁾
I3	NEPSI Intrinsic Safety
IC	NEPSI FISCO Intrinsic Safety
E4	TIIS Flameproof ⁽³⁾
E5	FM Explosion-proof ⁽¹⁾
I5	FM Intrinsic Safety and Non-incendive
IE	FM FISCO Intrinsic Safety ⁽²⁾
E6	CSA Explosion-proof ⁽¹⁾
I6	CSA Intrinsic Safety
IF	CSA FISCO Intrinsic Safety ⁽²⁾
E7	IECEX Flameproof ⁽¹⁾
I7	IECEX Intrinsic Safety
IG	IECEX FISCO Intrinsic Safety ⁽²⁾

Product Data Sheet

00813-0100-4026, Rev FB

February 2008

Rosemount 5400 Series

Code	Antenna - Size and Material (for process connection availability, refer to "Dimensional Drawings and Mechanical Properties" on page 21)
Cone Antennas	
2S	2 in. DN 50, 316L SST (EN 1.4404)
3S	3 in. DN 80, 316L SST (EN 1.4404)
4S	4 in. DN 100, 316L SST (EN 1.4404)
2H	2 in. DN 50, Hastelloy® C-276 (UNS N10276) with wetted flange plate
3H	3 in. DN 80, Hastelloy® C-276 (UNS N10276) with wetted flange plate
4H	4 in. DN 100, Hastelloy® C-276 (UNS N10276) with wetted flange plate
2M	2 in. DN 50, Monel® 400 (UNS N04400) with wetted flange plate
3M	3 in. DN 80, Monel® 400 (UNS N04400) with wetted flange plate
4M	4 in. DN 100, Monel® 400 (UNS N04400) with wetted flange plate
2N	2 in. DN 50, 316L SST (EN 1.4404), with wetted flange plate. Complies with guidelines in NACE® MR0175/ISO 15156 and NACE® MR0103.
3N	3 in. DN 80, 316L SST (EN 1.4404), with wetted flange plate. Complies with guidelines in NACE® MR0175/ISO 15156 and NACE® MR0103.
4N	4 in. DN 100, 316L SST (EN 1.4404), with wetted flange plate. Complies with guidelines in NACE® MR0175/ISO 15156 and NACE® MR0103.
Process Seal Antennas	
2P	2 in. DN 50, PTFE
3P	3 in. DN 80, PTFE
4P	4 in. DN 100, PTFE
Other Antennas	
XX	Customer specific
Code	Tank Sealing
PV	PTFE with Viton® fluoroelastomer o-rings
PK	PTFE with Kalrez® 6375 perfluoroelastomer o-rings
PE	PTFE with EPDM o-rings
PB	PTFE with Buna-N o-rings
Code	Process Connection and Material (for antenna availability, refer to "Dimensional Drawings and Mechanical Properties" on page 21)
ANSI Flanges (316 / 316L SST)	
AA	2 inch, 150 lbs
AB	2 inch, 300 lbs
BA	3 inch, 150 lbs
BB	3 inch, 300 lbs
CA	4 inch, 150 lbs
CB	4 inch, 300 lbs
DA	6 inch, 150 lbs
EA	8 inch, 150 lbs
EN (DIN) Flanges (EN 1.4404 SST)	
HB	DN 50 PN 40
IB	DN 80 PN 40
JA	DN 100 PN 16
JB	DN 100 PN 40
KA	DN 150 PN 16
LA	DN 200 PN 16
JIS Flanges (EN 1.4404 SST)	
UA	50A 10K
VA	80A 10K
XA	100A 10K
YA	150A 10K
ZA	200A 10K
Other Flanges	
BR	Bracket Mounting, 316L / EN 1.4404 SST ⁽⁴⁾
XX	Customer specific

Rosemount 5400 Series

Code	Options
M1	Integral digital display
GC	Transparent meter glass protection cover made of PTFE / FEP
T1	Transient Protection Terminal Block (standard with FISCO options)
Software Configuration	
C1	Factory configuration (CDS required with order)
Alarm Limit Configuration	
C4	NAMUR alarm and saturation levels, high alarm
C8	Low alarm ⁽⁵⁾ (standard Rosemount alarm and saturation levels)
Special Certificates	
N2	Certificate of compliance with guidelines in NACE [®] MR0175/ISO 15156 and NACE [®] MR0103 ⁽⁶⁾
Q4	Calibration Data Certificate
Q8	Material Traceability Certification per EN 10204 3.1 ⁽⁷⁾
Special Procedures	
P1	Hydrostatic testing ⁽⁴⁾
Antenna Modification	
S3 (pending)	Cone antenna extension in 316 / 316L / EN 1.4404 SST. To be used if there are irregularities in the nozzle. Fits nozzles up to 20 in. (500 mm) ⁽⁸⁾ .
Typical Model Number: 5402 A H 1 E5 4S PV CA - M1 C1	

- (1) Options E (eurofast[®]) and M (minifast[®]) are not available with Explosion-proof or Flameproof approvals.
- (2) Requires Foundation™ fieldbus signal output (U_i parameter listed in "Product Certifications" on page 18).
- (3) G ½ in. SST cable gland is included in delivery.
- (4) Bracket mounting (BR) is not available with hydrostatic testing (P1).
- (5) The standard alarm setting is high.
- (6) Requires wetted flange plate cone antennas (2H-4H, 2M-4M, 2N-4N) or process seal antennas (2P-4P).
- (7) Certificate includes all pressure retaining wetted parts.
- (8) Requires a SST cone antenna (2S-4S).

Product Data Sheet

00813-0100-4026, Rev FB

February 2008

Rosemount 5400 Series

Model Code for Rosemount 5401 Radar Level Transmitter

Model	Product Description
5401	Low frequency version (~6 GHz)
Code	Housing Material
A	Polyurethane-covered Aluminum
Code	Signal Output
H	4-20 mA with HART® communication
F	FOUNDATION™ fieldbus
Code	Conduit / Cable Threads
1	1/2 inch - 14 NPT
2	M20 x 1.5 adapter
E	M12, 4-pin, Male Connector (eurofast®)(1)
M	A size Mini, 4-pin, Male Connector (minifast®)(1)
Code	Product Certifications
NA	No Product Certificates
E1	ATEX Flameproof(1)
I1	ATEX Intrinsic Safety
IA	ATEX FISCO Intrinsic Safety(2)
E3	NEPSI Flameproof(1)
I3	NEPSI Intrinsic Safety
IC	NEPSI FISCO Intrinsic Safety
E4	TIIS Flameproof(3)
E5	FM Explosion-proof(1)
I5	FM Intrinsic Safety and Non-incendive
IE	FM FISCO Intrinsic Safety(2)
E6	CSA Explosion-proof(1)
I6	CSA Intrinsic Safety
IF	CSA FISCO Intrinsic Safety(2)
E7	IECEX Flameproof(1)
I7	IECEX Intrinsic Safety
IG	IECEX FISCO Intrinsic Safety(2)

Rosemount 5400 Series

Code	Antenna - Size and Material (for process connection availability, refer to "Dimensional Drawings and Mechanical Properties" on page 21)
Cone Antennas	
3S	3 in. DN 80, 316L SST (EN 1.4404), pipe installations only
4S	4 in. DN 100, 316L SST (EN 1.4404)
6S	6 in. DN 150, 316L SST (EN 1.4404)
8S	8 in. DN 200, 316L SST (EN 1.4404)
3H	3 in. DN 80, Hastelloy [®] C-276 (UNS N10276) with wetted flange plate, pipe installations only
4H	4 in. DN 100, Hastelloy [®] C-276 (UNS N10276) with wetted flange plate
6H	6 in. DN 150, Hastelloy [®] C-276 (UNS N10276) with wetted flange plate
8H	8 in. DN 200, Hastelloy [®] C-276 (UNS N10276) with wetted flange plate
3M	3 in. DN 80, Monel [®] 400 (UNS N04400) with wetted flange plate, pipe installations only
4M	4 in. DN 100, Monel [®] 400 (UNS N04400) with wetted flange plate
6M	6 in. DN 150, Monel [®] 400 (UNS N04400) with wetted flange plate
8M	8 in. DN 200, Monel [®] 400 (UNS N04400) with wetted flange plate
3N	3 in. DN 80, 316L SST (EN 1.4404), with wetted flange plate, pipe installations only. Complies with guidelines in NACE [®] MR0175/ISO 15156 and NACE [®] MR0103.
4N	4 in. DN 100, 316L SST (EN 1.4404), with wetted flange plate. Complies with guidelines in NACE [®] MR0175/ISO 15156 and NACE [®] MR0103.
6N	6 in. DN 150, 316L SST (EN 1.4404), with wetted flange plate. Complies with guidelines in NACE [®] MR0175/ISO 15156 and NACE [®] MR0103.
8N	8 in. DN 200, 316L SST (EN 1.4404), with wetted flange plate. Complies with guidelines in NACE [®] MR0175/ISO 15156 and NACE [®] MR0103.
Rod Antennas	
1R	Short version, all-PFA ⁽⁴⁾⁽⁵⁾ , with wetted flange plate, max. nozzle height 4 in. (100 mm), free propagation only
2R	Long version, all-PFA ⁽⁴⁾⁽⁵⁾ , with wetted flange plate, max. nozzle height 10 in. (250 mm), free propagation only
3R	Short version, SST+PFA ⁽⁴⁾ , max. nozzle height 4 in. (100 mm), free propagation only
4R	Long version, SST+PFA ⁽⁴⁾ , max. nozzle height 10 in. (250 mm), free propagation only
Other Antennas	
XX	Customer specific
Code	Tank Sealing
PV	PTFE with Viton [®] fluoroelastomer o-rings
PK	PTFE with Kalrez [®] 6375 perfluoroelastomer o-rings
PE	PTFE with EPDM o-rings
PB	PTFE with Buna-N o-rings
PD	All-PFA ⁽⁴⁾ rod antennas (O-rings are not wetted)
Code	Process Connection and Material (for antenna availability, refer to "Dimensional Drawings and Mechanical Properties" on page 21)
ANSI Flanges (316 / 316L SST)	
AA	2 in. 150 lbs
AB	2 in. 300 lbs
BA	3 in. 150lbs
BB	3 in. 300 lbs
CA	4 in. 150 lbs
CB	4 in. 300 lbs
DA	6 in. 150 lbs
EA	8 in. 150 lbs
EN (DIN) Flanges (EN 1.4404 SST)	
HB	DN 50 PN 40
IB	DN 80 PN 40
JA	DN 100 PN 16
JB	DN 100 PN 40
KA	DN 150 PN 16
LA	DN 200 PN 16

Product Data Sheet

00813-0100-4026, Rev FB

February 2008

Rosemount 5400 Series

Code	Process Connection and Material (continued)
JIS Flanges (EN 1.4404 SST)	
UA	50A 10K
VA	80A 10K
XA	100A 10K
YA	150A 10K
ZA	200A 10K
Threaded (316L / EN 1.4404 SST)	
RA	1.5-in. NPT ⁽⁶⁾
Other	
BR	Bracket Mounting, 316L / EN 1.4404 SST ⁽⁶⁾
XX	Customer specific
Code	Options
M1	Integral digital display
GC	Transparent meter glass protection cover made of PTFE / FEP
T1	Transient Protection Terminal Block (standard with FISCO options)
Software Configuration	
C1	Factory configuration (CDS required with order)
Alarm Limit Configuration	
C4	NAMUR alarm and saturation levels, high alarm
C8	Low alarm ⁽⁷⁾ (standard Rosemount alarm and saturation levels)
Special Certificates	
N2	Certificate of compliance with guidelines in NACE [®] MR0175/ISO 15156 and NACE [®] MR0103 ⁽⁸⁾
Q4	Calibration Data Certificate
Q8	Material Traceability Certification per EN 10204 3.1 ⁽⁹⁾
Special Procedures	
P1	Hydrostatic testing ⁽⁶⁾
Antenna Modification	
S3	Extended Cone Antenna in 316 / 316L / EN 1.4404 SST. Maximum recommended nozzle height is 20 in. (500 mm). ⁽¹⁰⁾
Typical Model Number: 5401 A H 1 NA 4S PV CA - M1 C1	

- (1) Options E (eurofast[®]) and M (minifast[®]) are not available with Explosion-proof or Flameproof approvals.
- (2) Requires Foundation™ fieldbus signal output (U₁ parameter listed in "Product Certifications" on page 18).
- (3) G ½ in. SST cable gland is included in delivery.
- (4) PFA is a fluoropolymer with properties similar to PTFE.
- (5) All-PFA Rod antennas (1R or 2R) require all-PFA tank seal (PD).
- (6) Certain process connections are not available with hydrostatic testing (P1).
- (7) The standard alarm setting is high.
- (8) Requires wetted flange plate cone antennas (3H-8H, 3M-8M, 3N-8N) or rod antennas (1R-4R).
- (9) Certificate includes all pressure retaining wetted parts.
- (10) Requires a SST cone antenna (3S-8S).

Application & Configuration Data Sheet, continued

*=Indicates default factory configuration.

Analog Output (4-20 mA analog output), not applicable for FOUNDATION™ fieldbus devices - Information is required if C1 is ordered

Primary Variable (PV) Level* Distance Volume Level Rate⁽¹⁾ Signal Strength⁽²⁾

Lower Range Value (4 mA) _____ (use the selected variable unit on previous page)

Upper Range Value (20 mA) _____ (use the selected variable unit on previous page)

Alarm Mode High* Low Freeze

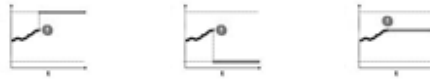

Tank Geometry - Information is required if C1 is ordered

Tank Shape

Select a tank type corresponding to the actual tank on which the device is mounted. If the device is mounted on a tank type that is not available as an individual selection choose Unknown.

Unknown* Vertical Cylinder Horizontal Cylinder
 Spherical Cubical⁽³⁾

Tank Bottom⁽⁴⁾

Select a Tank Bottom Type that corresponds to the actual shape of the tank bottom.

Unknown* Flat⁽⁵⁾ Dome/Dish/Bullet



Cone

Other (e.g. inclined)

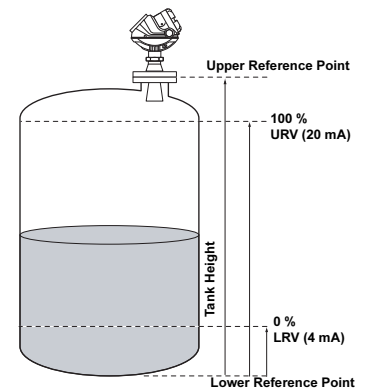
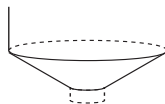

Tank Height _____ (use variable unit chosen on previous page)

- (1) Always in selected level unit per second.
- (2) Always in mV.
- (3) A cubical tank type is defined as a box shaped tank with right angles.
- (4) Tank Bottom Type is only applicable for Vertical Cylinder and Cubical tanks.
- (5) Bottom of the tank is < 5°.

Application & Configuration Data Sheet, continued

Fitting Dimensions - Information is required if C1 is ordered

Please fill in the dimensions (according to selected variable unit)

Nozzle

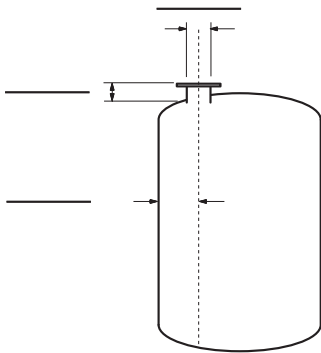

Stilling Well

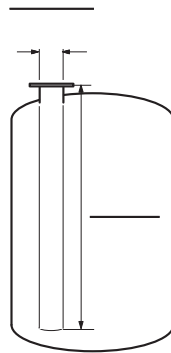

Bypass Pipe

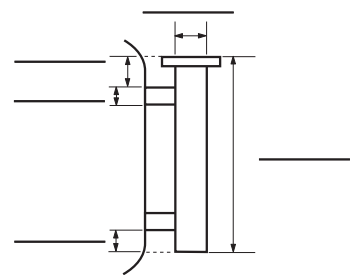

Application & Configuration Data Sheet, continued

VOLUME CONFIGURATION

Volume Configuration Information (total volume calculation only) - Required if C1 is ordered and Volume is chosen variable

Volume is calculated based on ideal tank types or a strapping table. Please mark the box that corresponds to your tank type and fill in dimensions on the lines according to the previously selected variable unit.

Vertical Cylinder

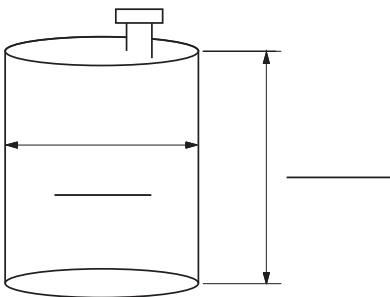

Horizontal Cylinder

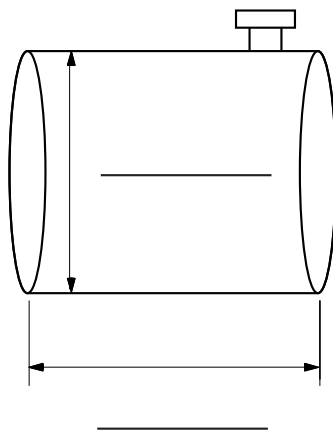

Vertical Cylinder with Bullet Ends

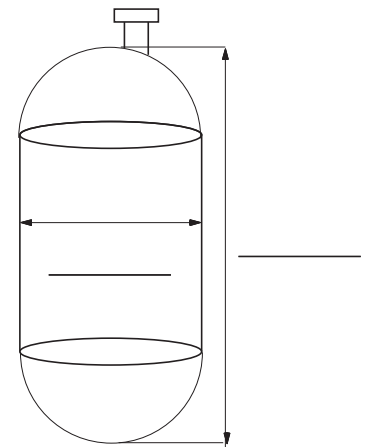

Horizontal Cylinder with Bullet Ends

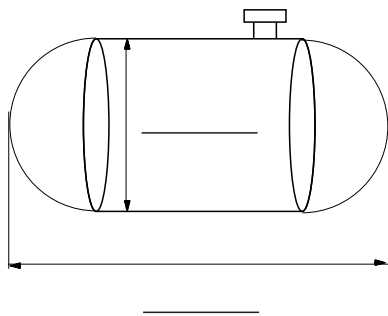

Sphere

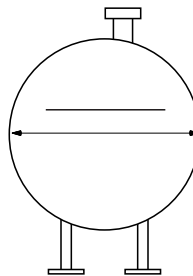

Rosemount 5400 Series

Product Data Sheet
00813-0100-4026, Rev FB
February 2008

Product Data Sheet

00813-0100-4026, Rev FB

February 2008

Rosemount 5400 Series

Rosemount Level Solutions

Emerson provides a complete range of Rosemount products for level measurement applications.

Pressure – Level or Interface Measurement

Emerson has a complete line of Rosemount pressure transmitters and remote seals for measuring level or interfaces in liquid applications. Optimize performance with direct mount, Tuned Seal systems:

- Rosemount 3051S_L, 3051L, and 1151LT Liquid Level Transmitters
- Rosemount 1199 Remote Diaphragm Seals with direct mount or capillary connections

Vibrating Fork Switches – Point Level Detection

The Rosemount 2100 Series is developed for reliable point level detection of liquids and consists of:

- Rosemount 2110 Compact Vibrating Fork Liquid Level Switch
- Rosemount 2120 Full-featured Vibrating Fork Liquid Level Switch

Guided Wave Radar – Level and Interface Measurement

Multivariable, loop-powered Guided Wave Radar transmitters with a wide range of probe styles to fit different liquids and solids applications. The product line consists of:

- Rosemount 3300 Series – Versatile and easy-to-use transmitter with proven reliability
- Rosemount 5300 Series – Accurate, high performance transmitter with FOUNDATION™ fieldbus support

Non-contacting Radar – Level Measurement

The Rosemount non-contacting radar family consists of:

- Rosemount 5400 Series Transmitters – Loop-powered transmitter with a wide range of antennas, for liquid level measurement in most applications and process conditions
- Rosemount 5600 Series Transmitters – Transmitters with ultra-high sensitivity for measurement of level in liquids and solids, even for the most challenging applications

Non-contacting Ultrasonic – Level Measurement

The Rosemount 3100 Series ultrasonic level transmitters provide continuous non-contacting level measurement of liquids. The range consists of:

- Rosemount 3101 for simple continuous level measurement
- Rosemount 3102 for continuous measurement with two integral relays for local control functionality
- Rosemount 3105 Intrinsically safe certified version for hazardous areas

*Rosemount and the Rosemount logotype are registered trademarks of Rosemount Inc.
PlantWeb is a registered trademark of one of the Emerson Process Management group of companies.
HART is a registered trademark of the HART Communication Foundation
Viton, and Kalrez are registered trademarks of Du Pont Performance Elastomers.
FOUNDATION is a trademark of the Fieldbus Foundation.
DeltaV is a trademark of Emerson Process Management group of companies.
Hastelloy is a registered trademark of Haynes International.
Monel is a registered trademark of International Nickel Co.
Eurofast and Minifast are registered trademarks of Turck Inc.
All other marks are the property of their respective owners.*

Standard Terms and Conditions of Sale can be found at www.rosemount.com/terms_of_sale

Emerson Process Management, Rosemount Inc.

The Americas

Emerson Process Management
8200 Market Boulevard
Chanhassen, MN 55317 USA
T (U.S.) 1-800-999-9307
T (International) (952) 906-8888
F (952) 949-7001

Europe, Middle East & Africa

Emerson Process Management
Shared Services Ltd.
Heath Place
Bognor Regis
West Sussex PO22 9SH
England
Tel 44 1243 845500
Fax 44 1243 867554

Asia Pacific

Emerson Process Management
Singapore Pte Ltd.
1 Pandan Crescent
Singapore 128461
Tel 65 6777 8211
Fax 65 6777 0947
AP.RMT-Specialist@emersonprocess.com

www.rosemount.com

