

For Additional Product Information:

If QR code is not affixed here, product documents can be located by entering your product's S/N into the search tool (magnifier icon) at the top of the webpage found at www.emerson.com



Quick Start Guide
MS-00825-0100-6201, Rev AA
November 2025

Rosemount™ 4051S Pressure Transmitters

with 4-20 mA HART® Protocol



ROSEMOUNT™

EMERSON

WARNING

Read this document before working with the product. For personal and system safety and for optimum product performance, ensure that you thoroughly understand the contents before installing, using, and maintaining the product.

Failure to follow safe installation and servicing guidelines could result in death or serious injury.

Ensure the transmitter is installed by qualified personnel and in accordance with applicable code of practice. Use the transmitter only as specified in the product manual. Failure to do so may impair the protection provided by the transmitter.

Repair, e.g. substitution of components, etc. may jeopardize safety and is under no circumstances allowed. Unauthorized changes to the product are strictly prohibited, as they may unintentionally and unpredictably alter performance and jeopardize safety. Unauthorized changes that interfere with the integrity of the welds or flanges, such as making additional perforations, compromise product integrity and safety. Equipment ratings and certifications are no longer valid on any products that have been damaged or modified without the prior written permission of Emerson. Any continued use of product that has been damaged or modified without the written authorization is at the customer's sole risk and expense.

Explosions

Explosions could result in death or serious injury.

In an explosion-proof/flameproof installation, do not remove the transmitter covers when power is applied to the transmitter. Installation of this transmitter must be in accordance with the appropriate local, national, and international standards, codes, and practices. Before connecting a field communicator in an explosive atmosphere, ensure that the instruments are installed in accordance with intrinsically safe or non-incendive field wiring practices.

Process leaks

Process leaks may cause harm or result in death.

Install and tighten process connectors before applying pressure. Do not remove while in operation.

Electrical shock

Electrical shock can result in death or serious injury.

Avoid contact with the leads and terminals. High voltage that may be present on leads can cause electrical shock. Ensure the power to the transmitter is off and the lines to any other external power source are disconnected or not powered while wiring the transmitter. Ensure the wiring is suitable for the electrical current and the insulation is suitable for the voltage, temperature, and environment.

Replacement equipment

The use of replacement equipment or spare parts not approved by Emerson may reduce the pressure retention or other safety capabilities of the transmitter and may lead to dangerous or unsafe conditions.

Use only bolts, replacement equipment, or other spare parts supplied or approved by Emerson.

When cover is removed, protect the interior of the transmitter from external contamination exceeding that of a Pollution Degree 2 environment.

⚠ WARNING

Physical access

Unauthorized personnel may potentially cause significant damage to and/or misconfiguration of end users' equipment. This could be intentional or unintentional and needs to be protected against.

Physical security is an important part of any security program and fundamental in protecting your system. Restrict physical access by unauthorized personnel to protect end users' assets. This is true for all systems used within the facility.

1 About this guide

This guide provides basic installation guidelines for Rosemount 4051S Transmitters.

It does not provide instructions for configuration, diagnostics, maintenance, troubleshooting, explosion-proof, flameproof, or intrinsically safe (IS) installations. Refer to the *Rosemount 4051S Pressure Transmitter Manual* for more instructions.

This guide and the referenced manual are also available electronically at [Emerson.com](https://www.emerson.com).

2 Mounting the transmitter

For dimensional drawings, refer to the *Documents & Drawings* section on [Rosemount 4051S Pressure Transmitter](#).

⚠ WARNING

Process connection temperatures above 185 °F (85 °C) require a limited ambient temperature, reduced by a 1:1.5 ratio. Consider process connection and ambient temperatures when installing the transmitter with hazardous location certifications. See [Table 2-1](#).

Table 2-1: Intrinsically Safe/Increased Safety

Process connection temperature	Maximum ambient temperature
-76 to +185 °F (-60 to +85 °C)	158 °F (170 °C)
185 to 250 °F (85 to 121 °C)	158 to 60 °F (70 to 16 °C) ⁽¹⁾

(1) *Maximum ambient temperature is reduced by 1.5 degree for 1 degree temperature rise in the process connection temperature beyond 185 °F (85 °C).*

2.1 Using a mounting bracket

Refer to the *Rosemount 4051S Pressure Transmitter Manual* for images and instructions on how to properly mount the transmitter using the mounting brackets provided by Emerson.

NOTICE

Use only bolts provided with the transmitter or sold as Emerson spare parts. Tighten bolts to a torque of 125 in-lb.

2.2 Install bolts

If the transmitter installation requires assembly of a process flange, manifold, or flange adapters, follow assembly guidelines to ensure a tight seal for optimal performance characteristics of the transmitter.

[Figure 2-1](#) illustrates common transmitter assemblies with the bolt length required for proper transmitter assembly.

Figure 2-1: Common Transmitter Assemblies

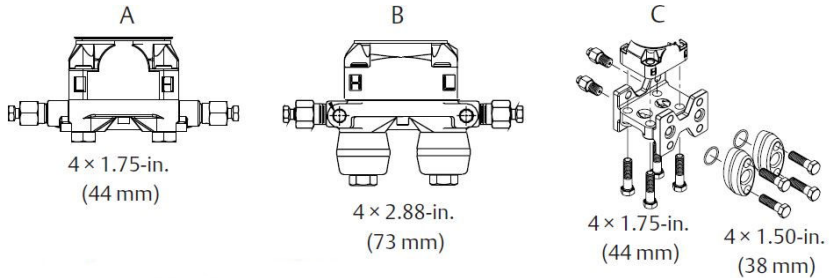









- A. Transmitter with Coplanar™ flange
 B. Transmitter with Coplanar flange and optional flange adapters
 C. Transmitter with traditional flange and optional flange adapters

NOTICE

For all other assemblies, refer to the related manual or contact Rosemount Customer Central technical support.

Carbon steel bolts do not require lubrication, and stainless steel bolts are coated with a lubricant to ease installation. Do not apply additional lubricant when installing either type of bolt.

Table 2-2: Torque Values for the Flange and Flange Adapter Bolts

Bolt material	Head markings	Initial torque	Final torque
Carbon steel (CS)	 	300 in-lb.	650 in-lb.
Stainless steel (SST)	     	150 in-lb.	300 in-lb.

Procedure

1. Finger-tighten the bolts.
2. Torque the bolts to the initial torque value using a crossing pattern. Then, torque the bolts to the final torque value using the same crossing pattern.
 See [Table 2-2](#) for initial and final torque values.
3. Verify the flange bolts are protruding through the sensor module before applying pressure.

2.3 Mounting requirements

Impulse piping configurations depend on specific measurement conditions. Refer to [Figure 2-2](#) for examples of the following mounting configurations:

Liquid measurement

- Place taps to the side of the line to prevent sediment deposits on the transmitter’s process isolators.
- Mount the transmitter beside or below the taps so gases can vent into the process line.
- Mount drain/vent valve upward to allow gases to vent.

Gas measurement

- Place taps in the top or side of the line.
- Mount the transmitter beside or above the taps so liquid will drain into the process line.

Steam measurement

- Place taps to the side of the line.
- Mount the transmitter below the taps to ensure that the impulse piping will stay filled with condensate.
- In steam service above 250 °F (121 °C), fill impulse lines with water to prevent steam from contacting the transmitter directly and to ensure accurate measurement start-up.

NOTICE

For steam or other elevated temperature services, it is important that temperatures at the process connection do not exceed the transmitter's process temperature limits.

Figure 2-2: Installation Examples

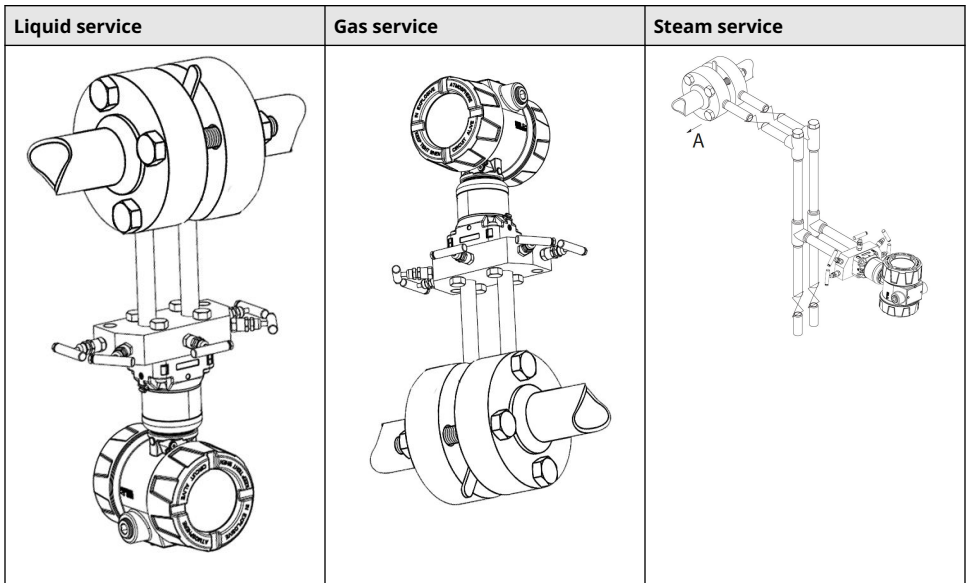

A. Flow

For additional mounting best practices, refer to the *Rosemount 4051S Pressure Transmitter Manual*.

2.4 O-rings with flange adapters

⚠ WARNING

Process leaks

Process leaks could result in death or serious injury.

To avoid process leaks, only use the O-ring designed to seal with the corresponding flange adapter.

2.5 In-line gauge transmitter orientation

The low side pressure port (atmospheric reference) on the in-line gauge transmitter is located under the sensor module neck label.

Keep the vent path free of any obstruction, including but not limited to paint, dust, and lubrication, by mounting the transmitter so that any contaminants can drain away.

3 Rotate housing

To improve field access to wiring or to better view the optional LCD display:

NOTICE

Over-rotation may sever the electrical connection between the sensor module and the electronics.

Do not rotate the housing more than 180° without first disassembling the transmitter.

Procedure

1. Loosen the external 1/8-inch housing rotation set screw located on the side of the transmitter housing below the conduit entry and near the (option) external ground.
2. Turn the housing up to 180° left or right of its original (as shipped) position.
3. Re-tighten the housing rotation set screw.

4 Connect wiring and power up

⚠ WARNING

Do not remove the instrument cover in explosive atmospheres when the circuit is live.

Procedure

1. Remove and discard orange shipping plugs in the conduit entries.
2. Remove the field terminals housing cover as indicated on the device.
3. Connect the positive lead to the “+” terminal, and the negative lead to the “-” terminal.
4. If grounding is required for transient protection or to fulfill local regulations, connect the ground wire as indicated in [Figure 4-1](#). The cable shield should be:
 - Trimmed close and insulated from touching the transmitter housing
 - Continuously connected to the termination point
 - Connected to a good earth ground at the power supply end

⚠ CAUTION

When the enclosed threaded plug is used in the conduit opening, it must be installed with a minimum thread engagement in order to comply with explosion-proof requirements.

For straight threads, a minimum of seven threads must be engaged. For tapered threads, a minimum of five threads must be engaged.

5. Plug and seal the unused conduit connection with the provided conduit plug.
For Rosemount 4051S with conduit electrical connectors GE or GM, refer to the cordset manufacturer's installation instructions for wiring details.
6. If applicable, install wiring with a drip loop. Arrange the drip loop so the bottom is lower than the conduit connections and the transmitter housing.

7. Reinstall the housing cover and tighten so the cover is fully seated with metal to metal contact between the housing and cover in order to meet explosion-proof requirements.

NOTICE

Installation of the transient protection terminal block does not provide transient protection unless the 4051S case is properly grounded.

Figure 4-1: Wiring

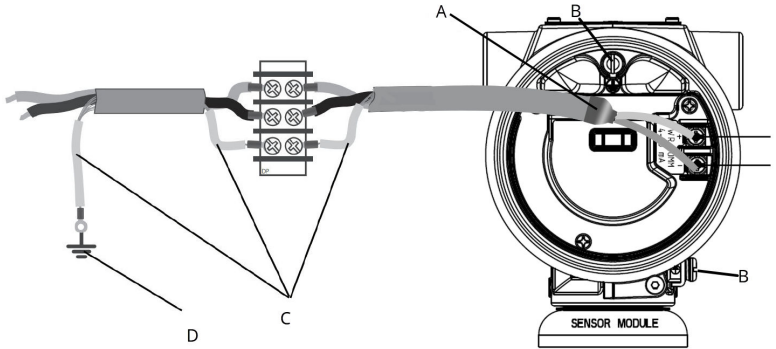

- Insulate shield and drain wire.*
- Grounding option*
- Insulate exposed shield drain wire.*
- Terminate cable shield to earth ground.*

4.1 Remote display wiring and power up

The remote mount display and interface system consists of a local sensor module and a remote mount LCD display assembly. The local Rosemount 4051S Transmitter assembly includes a housing integrally mounted to a sensor module. The remote mount LCD display assembly consists of a housing with a ten position terminal block.

Refer to the *Rosemount 4051S Pressure Transmitter Manual* for more information, cable specifications, and requirements.

⚠ WARNING

Intrinsic safety (IS) consideration

Cable parameters must be considered for remote display intrinsically safe installations.

Alternative cables may be used if the transmitter with remote display and cable is configured according to the installation control drawing or certificate. Refer to appropriate approval certificate or control drawing in for remote cable IS requirements.

NOTICE

Do not apply power to the remote communications terminal. Follow wiring instructions carefully to prevent damage to system components.

NOTICE

For ambient temperatures above 140 °F (60 °C), cable wiring must be rated at least 9 °F (5 °C) above the maximum ambient temperature.

Figure 4-2: Remote Mount Display Wiring Diagram

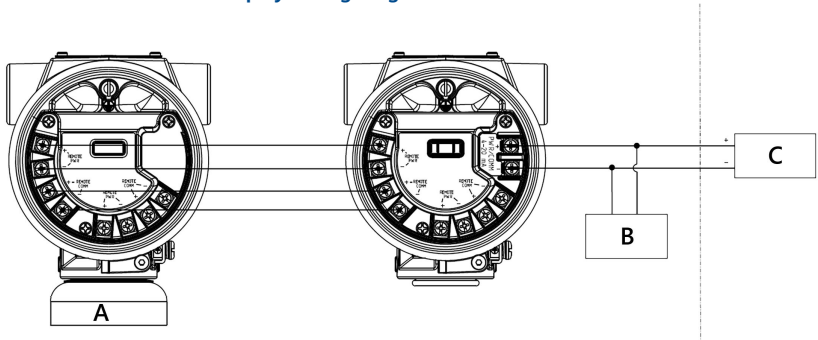

- A. Sensor module
- B. Approved commissioning device
- C. Approved associated apparatus

Note

Wire color may vary depending on cable selected.

4.2 Power supply

The transmitter requires an external power supply providing between 11.5 to 42.4 Vdc at the terminals to operate. The total resistance load is the sum of the resistance of the signal leads and the load resistance of the controller, indicator, and related pieces.

Maximum loop resistance = $42.37 \times (\text{power supply voltage} - 11.5)$. The communication device requires a minimum loop resistance of 250 Ω for communication. Refer to the *Rosemount 4051S Pressure Transmitter Manual* for more information.

NOTICE

The resistance of intrinsic safety barriers, if used, must be included.

4.3 Relay switches (Transmitter output code S)

The Rosemount 4051S Pressure Transmitter supports two integral high voltage, high current double pole changeover (DPCO) switches connected directly to the transmitter. An integral relay switch takes the traditional pressure relay switch and embeds it into the transmitter.

On the 4051S, the relay switches are in the transmitter terminal block. Use the **Process Alert** function to configure the relays, which are controlled by the transmitter measurement.

Depending on how the relay is wired, this will either break or complete the circuit of a connected power load. Each of the two relays has a normally closed (NC) terminal, normally open (NO) terminal, and common (COM) terminal. There is a positive and negative power terminal that powers the switch separately from the positive and negative power terminal that powers the transmitter.

Refer to the *Rosemount 4051S Pressure Transmitter Manual* for more information.

4.4 Using High Speed Sensor Response Time (option P6)

The **High Speed Response** option is available with option code P6. This option will change the transmitter response time to 40 ms.

The overall update rate will be dependent on **Damping** settings and if communication is via analog or HART®.

4.5 Set Alarm and Security switches

All Rosemount 4051S Transmitters come with Alarm and Security switches included. The transmitter will operate normally with the default **Alarm** condition High and the **Security** Off.

Refer to the related *Rosemount 4051S Pressure Transmitter Manual* for more detail on configuration of the **Alarm** and **Security** switches.

5 Wireless configuration using Bluetooth® technology

Refer to the *Rosemount 4051S Pressure Transmitter Manual* for additional installation and configuration considerations.

5.1 Download AMS Device Configurator

Procedure

Download and install the AMS Device Configurator app from your preferred app store.

Note

If this is your first time opening AMS Device Configurator, then you may be asked to allow the application to access media on your device and to access your device's location. If prompted, select **Allow**.

Figure 5-1: Emerson Application Icon



5.2 Configure using Bluetooth® wireless technology

Procedure

1. Launch AMS Device Configurator.
See [AMS Device Configurator for Emerson Field Devices](#).
2. Select the device you want to connect to.
3. On first connection, enter the **Unique Identifier (UID)** and **Key** for selected device and select the appropriate role.
4. At the top left, select the menu icon to navigate to the desired device menu.

5.2.1 Bluetooth® Unique Identifier (UID) and Key

You can find the **UID** and **Key** in the following locations:

- Disposable paper tag attached to the device
- Label inside the terminal block cover
- Label on the display unit

Figure 5-2: Bluetooth Security Information

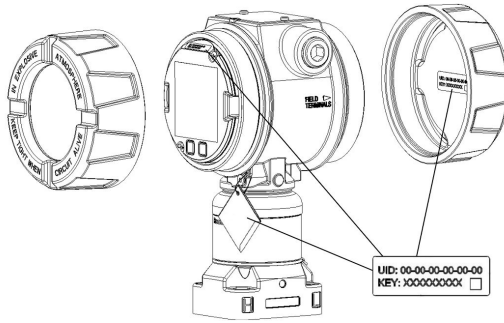

6 Verify configuration parameters

Verify configuration parameters with a HART®-compliant master before installation and install the latest device driver (DD) for optimal performance.

Use any HART-compliant master to communicate with and verify configuration of the Rosemount 4051S. Emerson recommends verifying various configuration parameters prior to installing the transmitter into the process: **Alarm** and **Saturation** levels, **Damping**, **Process variables**, **Tag**, **Transfer** function, and **Units**.

Refer to the *Rosemount 4051S Pressure Transmitter Manual* for detailed configuration details and more information.

Note

Emerson recommends installing the latest DD to ensure full functionality. Download the latest DD at [Software & Drivers](#).

7 Trim the transmitter

Emerson ships transmitters either:

- Fully calibrated per request
- By the factory default of full scale:
 - **Lower Range Value** = 0
 - **Upper Range Value** = upper range limit

Refer to the *Rosemount 4051S Pressure Transmitter Manual* for greater detail on the zero trim and **Quick Service** button capabilities.

7.1 Zero trim

A zero trim is a single-point adjustment used for compensating mounting position effects.

When performing a zero trim, ensure the equalizing valve is open and all wet legs are filled to the correct level.

There are two methods to compensate for mounting effects:

- Zero trim
- Using the transmitter **Quick Service** buttons

For zero trim procedures, refer to the *Rosemount 4051S Pressure Transmitter Manual*.

8 Safety Instrumented Systems (SIS)

For safety certified installations, refer to the *Rosemount 4051S Pressure Transmitter Manual*, available on [Emerson.com](https://www.emerson.com) for installation procedure and system requirements.

9 Product certifications

9.1 Ordinary location certification

The Rosemount 4051S has been examined and tested to determine that the design meets the basic electrical, mechanical, and fire protection requirements by one or more test laboratories, accredited as follows:

- As a Nationally Recognized Test Laboratory (NRTL) by the U.S. Federal Occupational Safety and Health Administration (OSHA).
- As a part of the Certification Body Accreditation Program (CBAP) by the Standards Council of Canada (SCC).

9.2 USA

9.2.1 USA Intrinsic Safety (IS) and Nonincendive (NI)

Certificate	FM25US0034X
Markings	IS: CL I, DIV 1, GP ABCD T4 CL II, DIV 1, GP EFG T4 CL III CL I, ZN 0, AEx ia IIC T4 Ga (-60°C ≤ Ta ≤ 70°C) NI: CL I, DIV 2, GP ABCD T4 CL II, DIV 2, GP FG T4 CL III (-60°C ≤ Ta ≤ 70°C) INSTALL PER 04151-1003 TYPE 4X IP66/IP68 OPTIONAL: DUAL SEAL - SEE PRODUCT MANUAL FOR TEMP RANGE

Specific conditions of use:

1. The enclosure may be made from aluminum alloy with a protective polyurethane paint finish. Care should be taken to protect it from impact or abrasion when located in a Division 1 or Zone 0 area.
2. When fitted with the transient suppression electronics option (T1), the equipment is not capable of passing the 500 V insulation test. This must be considered during installation.
3. Installation of the transmitter shall be limited to Overvoltage Category II.
4. Non-standard paint options may cause risk from electrostatic discharge. Avoid installations that could cause electrostatic build-up on painted surfaces and only clean the painted surfaces with a damp cloth. If paint is ordered through a special option code, contact the manufacturer for more information.

9.2.2 USA Explosionproof (XP) and Dust Ignition-Proof (DIP)

Certificate	FM24US0274X
Markings	EXP: Class I, Division 1, Groups B, C, D; T5 Zone 0/1 AEx db IIC T6...T4 Ga/Gb T6 (-50 °C ≤ Ta ≤ +70 °C), T5, T4 (-50 °C ≤ Ta ≤ +85 °C) DIP: Class II, Division 1, Groups E, F and G, Class III; T5 Zone 20 AEx ta IIIC T ₂₀₀ 110 °C Da

(-20 °C ≤ Ta ≤ +85 °C)
 IP66, IP68, Type 4X
 SEAL NOT REQUIRED
 DUAL SEAL

Specific conditions of use:

1. For AEx ta, the 4051S must be connected to supply with a short circuit rating no more than 1.5 kA.
2. Flameproof joints are not intended to be repaired.
3. The applicable temperature class, maximum surface temperature, ambient temperature range, and process temperature range of the equipment is as follows. Maximum ambient temperature is reduced by a ratio of 1:1.5 as process connection temperature increase beyond +85 °C.

Table 9-1:

Temperature class/ maximum surface temperature	Ambient temperature range (°C)	Process temperature Range (°C)
T6	-50 to +70	-50 to +85
T5	-50 to +85	-50 to +100
T4	-50 to +85	-50 to +121
T ₂₀₀ 110 °C	-20 to +85	-60 to +85

4. Appropriate cable, glands, and conduit seals need to be suitable for a temperature of 5 °C greater than the maximum specified ambient temperature for location where installed. Refer to temperature tables for various ambient and process temperature ranges.
5. The device contains a thin wall diaphragm less than 1 mm thick that forms a boundary between Zone 0 EPL Ga (process connection) and Zone 1 EPL Gb (all other parts of the equipment). The model code and data sheet are to be consulted for details of the diaphragm material. During installation, maintenance, and use the environmental conditions to which the diaphragm will be subjected shall be taken into account. The manufacturer's instructions for installation and maintenance shall be followed in detail to assure safety during its expected lifetime.

9.3 Canada

9.3.1 Canada Intrinsic Safety (IS), Nonincendive (NI)

Certificate FM25CA0016X

Markings IS CL I, DIV 1, GP ABCD; T4
 CL II, DIV 1, GP EFG; T4
 CL III
 Ex ia IIC T4 Ga
 (-60 °C ≤ Ta ≤ +70 °C)
 NI CL I, DIV 2, GP ABCD; T4
 CL II, DIV 2, GP FG; T4
 CL III
 (-60 °C ≤ Ta ≤ +70 °C)

INSTALL PER 04151-1003

TYPE 4X

IP66/IP68

AVERTISSEMENT - DANS UNE ATMOSPHÈRE EXPLOSIBLE GARDER BIEN FERME
 LORSQUE LE CIRCUIT EST SOUS TENSION

OPTIONAL: DUAL SEAL - SEE PRODUCT MANUAL FOR TEMP RANGE

Specific Conditions of Use:

1. The enclosure may be made from aluminum alloy with a protective polyurethane paint finish. Care should be taken to protect it from impact or abrasion when located in a Division 1 or Zone 0 area.
2. When fitted with the transient suppression electronics option (T1), the equipment is not capable of passing the 500 V insulation test. This must be considered during installation.
3. Installation of the transmitter shall be limited to Overvoltage Category II.

9.3.2 Canada Explosion-Proof, Dust Ignition-Proof

Certificate FM24CA0071X

Markings EXP CL I, DIV 1, GP B,C,D; T5

Ex db IIC T6...T4 Ga/Gb

T6 (-50 °C ≤ Ta ≤ +70 °C),

T5, T4 (-50 °C ≤ Ta ≤ +85 °C)

DIP CL II, DIV 1, GP E,F,G,

CL III; T5

Ex ta IIIC T200 110°C Da

(-20 °C ≤ Ta ≤ + 85 °C)

IP66, IP68, Type 4X

SEAL NOT REQUIRED

DUAL SEAL

AVERTISSEMENT - DANS UNE ATMOSPHÈRE EXPLOSIBLE GARDER BIEN FERME
LORSQUE LE CIRCUIT EST SOUS TENSION

Specific Conditions of Use

1. For Ex ta, the 4051S must be connected to supply with a short circuit rating no more than 1.5 kA.
2. Flameproof joints are not intended to be repaired.
3. The applicable temperature class, maximum surface temperature, ambient temperature range and process temperature range of the equipment is as follows. Maximum ambient temperature is reduced by a ratio of 1:1.5 as process connection temperature increase beyond +85 °C.

Temperature class/ maximum surface temperature	Ambient temperature range (°C)	Process temperature range (°C)
T6	-50 to +70	-50 to +85
T5	-50 to +85	-50 to +100
T4	-50 to +85	-50 to +121
T ₂₀₀ 110 °C	-20 to +85	-60 to +85

4. Appropriate cable, glands, and conduit seals need to be suitable for a temperature of 5 °C greater than the maximum specified ambient temperature for location where installed. Refer to temperature tables for various ambient and process temperature ranges.
5. The device contains a thin wall diaphragm less than 1 mm thick that forms a boundary between Zone 0 EPL Ga (process connection) and Zone 1 EPL Gb (all other parts of the equipment). The model code and data sheet are to be consulted for details of the diaphragm material. During installation, maintenance, and use the environmental conditions to which the diaphragm will be subjected shall be taken into account. The manufacturer's instructions for installation and maintenance shall be followed in detail to assure safety during its expected lifetime.

9.4 Europe

9.4.1 ATEX Intrinsic Safety (Ex ia)

EU-Type Certificate

FM25ATEX0006X

Markings

Ⓔ II 1 G Ex ia IIC T4 Ga
(-60 °C ≤ Ta ≤ +70 °C)
IP66 / IP68
SEE CERTIFICATE

Specific Conditions of Use:

1. The enclosure may be made from aluminum alloy with a protective polyurethane paint finish. Care should be taken to protect it from impact or abrasion when located in a Zone 0 area.
2. When fitted with the transient suppression electronics option (T1), the equipment is not capable of passing the 500V insulation test. This must be considered during installation.
3. Installation of the transmitter shall be limited to Overvoltage Category II.
4. Non-standard paint options may cause risk from electrostatic discharge. Avoid installations that could cause electrostatic build-up on painted surfaces and only clean the painted surfaces with a damp cloth. If paint is ordered through a special option code, contact the manufacturer for more information.

9.4.2 ATEX Increased Safety (Zone 2/Ex ec)

Type Certificate FM25ATEX0007X

Markings

Ⓔ II 3 G Ex ec IIC T4 Gc
(-60 °C ≤ Ta ≤ +70 °C)
IP66 / IP68

Specific Conditions of Use:

1. When fitted with the transient suppression electronics option (T1), the equipment is not capable of passing the 500V insulation test. This must be considered during installation.
2. Non-standard paint options may cause risk from electrostatic discharge. Avoid installations that could cause electrostatic build-up on painted surfaces and only clean the painted surfaces with a damp cloth. If paint is ordered through a special option code, contact the manufacturer for more information.

9.4.3 ATEX Flameproof, Dust Ignition-Proof

Certificate FM24ATEX0037X

Markings

Ⓔ II 1/2 G Ex db IIC T6...T4 Ga/Gb
T6 (-60 °C ≤ Ta ≤ +70 °C)
T5, T4 (-60 °C ≤ Ta ≤ +80 °C)
Ⓔ II 1 D Ex ta IIIC T₂₀₀110 °C Da
(-20 °C ≤ Ta ≤ +85 °C)
IP66, IP68

Specific Conditions of Use:

1. For Ex ta, the Rosemount 4051S must be connected to supply with a short circuit rating no more than 1.5 kA.
2. Flameproof joints are not intended to be repaired.
3. The applicable temperature class, maximum surface temperature, ambient temperature range and process temperature range of the equipment is as follows. Maximum ambient temperature is reduced by a ratio of 1:1.5 as process connection temperature increase beyond +85 °C.

Table 9-2:

Temperature class/ maximum surface temperature	Ambient temperature range (°C)	Process temperature range (°C)
T6	-60 to +70	-60 to +85
T5	-60 to +80	-60 to +100
T4	-60 to +80	-60 to +121
T ₂₀₀ 110 °C	-20 to +85	-60 to +85

- Appropriate cable, glands, and conduit seals need to be suitable for a temperature of 5 °C greater than the maximum specified ambient temperature for location where installed. Refer to temperature tables for various ambient and process temperature ranges.
- The device contains a thin wall diaphragm less than 1 mm thick that forms a boundary between EPL Ga (process connection) and EPL Gb (all other parts of the equipment). The model code and data sheet are to be consulted for details of the diaphragm material. During installation, maintenance, and use, the environmental conditions to which the diaphragm will be subjected shall be taken into account. The manufacturer's instructions for installation and maintenance shall be followed in detail to assure safety during its expected lifetime.
- Non-standard paint options may cause risk from electrostatic discharge. Avoid installations that could cause electrostatic build-up on painted surfaces and only clean the painted surfaces with a damp cloth. If paint is ordered through a special option code, contact the manufacturer for more information.

9.4.4 IECEx Intrinsic Safety (IS), Increased Safety (Zone 2/Ex ec)

Certificate IECEx FMG 25.0008X
 Ex ia IIC T4 Ga
 (-60 °C ≤ Ta ≤ +70 °C)
 Ex ec IIC T4 Gc
 (-60 °C ≤ Ta ≤ +70 °C)
 IP66 / IP68

Specific Conditions of Use:

- The enclosure may be made from aluminum alloy with a protective polyurethane paint finish. Care should be taken to protect it from impact or abrasion when located in a Zone 0 area.
- When fitted with the transient suppression electronics option (T1), the equipment is not capable of passing the 500 V insulation test. This must be considered during installation.
- Installation of the transmitter shall be limited to Overvoltage Category II.
- Non-standard paint options may cause risk from electrostatic discharge. Avoid installations that could cause electrostatic build-up on painted surfaces and only clean the painted surfaces with a damp cloth. If paint is ordered through a special option code, contact the manufacturer for more information.

9.4.5 IECEx Flameproof, Dust Ignition-proof

Certificate IECEx FMG 24.0041X
Markings Ex db IIC T6...T4 Ga/Gb
 T6 (-60 °C ≤ Ta ≤ +70 °C),
 T5, T4 (-60 °C ≤ Ta ≤ +80 °C)
 Ex ta IIIC T₂₀₀ 110 °C Da
 (-20 °C ≤ Ta ≤ +85 °C)
 IP66, IP68

Specific Conditions of Use:

1. For Ex ta, the Rosemount 4051S must be connected to supply with a short circuit rating no more than 1.5 kA.
2. Flameproof joints are not intended to be repaired.
3. The applicable temperature class, maximum surface temperature, ambient temperature range and process temperature range of the equipment is as follows. Maximum ambient temperature is reduced by a ratio of 1:1.5 as process connection temperature increase beyond 185 °F (85 °C).

Temperature class/maximum surface temperature	Ambient temperature range (°C)	Process temperature range (°C)
T6	-60 to +70	-60 to +85
T5	-60 to +80	-60 to +100
T4	-60 to +80	-60 to +121
T ₂₀₀ 110 °C	-20 to +80	-60 to +85

4. Appropriate cable, glands, and conduit seals need to be suitable for a temperature of 5 °C greater than the maximum specified ambient temperature for location where installed. Refer to temperature tables for various ambient and process temperature ranges.
5. The device contains a thin wall diaphragm less than 0.04 in. (1 mm) thick that forms a boundary between EPL Ga (process connection) and EPL Gb (all other parts of the equipment). The model code and data sheet are to be consulted for details of the diaphragm material. During installation, maintenance, and use, the environmental conditions to which the diaphragm will be subjected shall be taken into account. The manufacturer's instructions for installation and maintenance shall be followed in detail to assure safety during its expected lifetime.
6. Non-standard paint options may cause risk from electrostatic discharge. Avoid installations that could cause electrostatic build-up on painted surfaces and only clean the painted surfaces with a damp cloth. If paint is ordered through a special option code, contact the manufacturer for more information.



9.5 Y3 ATEX/IECEx RFID tag approvals

WARNING

Additional warnings

The plastic enclosure may present a potential electrostatic ignition hazard.

RFID tag is suitable for installation in a limited set of Zone classified locations and ambient temperature ranges when compared to the transmitter.

Certificate	EPS 15 ATEX 11011X
Markings	 II 2G Ex ia IIC T6/T4 Gb  II 2D Ex ia IIIC T80 °C/T130 °C Db
Certificate	IECEx EPS 15.0042X
Markings	Ex ia IIC T6/T4 Gb Ex ia IIIC T80 °C/T130 °C Db

Special Conditions of Use (X):

1. Maximum ambient temperature range:
-55 °C to +80 °C (T6 / T80 °C)
-55 °C to +110 °C (T4 / T130 °C)

2. The RFID tags shall never be exposed to high electromagnetic field strengths exceeding RMS values of 1 A/m or 3 V/m, e.g., in high current electrolysis plants.
3. Electrostatic charges shall be avoided. The tags shall never be used next to strong charge generating processes.

9.6 Declaration of Conformity



EU DECLARATION OF CONFORMITY



This declaration of conformity is issued under the sole responsibility of

Rosemount Inc.
6021 Innovation Blvd
Shakopee, MN 55379
USA

that the following products,

Rosemount™ 4051S Series Pressure Transmitters
Rosemount™ 4051SFx Series Flowmeter Transmitters
Rosemount™ 4051SLT Level Transmitter

comply with the provisions of the European Union Directives, including the latest amendments, valid at the time this declaration was signed.

November 10, 2025

(signature & date of issue)

Mark Lee
(name)

Vice President, Quality
(function)

Boulder, CO, USA
(place of issue)

Authorized Representative in Europe:
Emerson S.R.L., company No. J12/88/2006
Emerson 4 street, Parcul Industrial
Tetarom II, Cluj-Napoca 400638, Romania

Regulatory Compliance Shared Services Department
Email: europedproductcompliance@emerson.com Phone: +40 374 132 035

PED Notified Body:
DNV GL Business Assurance Italia S.r.l [Notified Body Number: 0496]
Via Energy Park
14, N-20871, Bimercate (MB)
Italy

ATEX Notified Bodies for EU Type Examination Certificates:
FM Approvals Europe Limited [Notified Body Number: 2809]
Element 78,
Ground Floor Block A,
One Georges Quay Plaza,
Dublin 2 D02 E440
Ireland

ATEX Notified Body for Quality Assurance:
SGS Fimko Oy [Notified Body Number: 0598]
Takomotie 8
FI-00380 Helsinki
Finland

EMC Directive (2014/30/EU)

Harmonized Standards:
EN 61326-1:2013
EN 61326-2-3:2013

Other Standards:
EN 301 489-1 V2.2.3
EN 301 489-17 V3.2.4

PED Directive (2014/68/EU)

Rosemount 4051S_CA4 & 4051S_CD2, 3, 4, 5
QS Certificate of Assessment - Certificate No. 12698-2018-CE-ACCREDIA
Module H Conformity Assessment

All other Rosemount 4051S Pressure Transmitters
Sound Engineering Practice

Transmitter Attachments: Diaphragm Seal, Process Flange, or Manifold
Sound Engineering Practice

Rosemount 4051SFx DP Flowmeter
See DSI 1000 Declaration of Conformity

RoHS Directive (2011/65/EU)

Harmonized Standards:
EN IEC 63000:2018

Radio Equipment Directive (RED) (2014/53/EU)

Harmonized Standards:
EN 18031-1:2024
EN 300 328 V2.2.2

Other Standards:
EN 62311:2020

ATEX Directive (2014/34/EU)

EU-Type Examination Certificate: FM25ATEX0006X
Equipment protection by intrinsic safety "i"
Equipment Group II, Category 1 G
Ex ia IIC T4 Ga

Harmonized Standards:
EN IEC 60079-0:2018+A11:2024
EN 60079-11:2012

Type Examination Certificate: FM25ATEX0007X
Equipment protection by increased safety "e"
Equipment Group II, Category 3 G
Ex ec IIC T5 Gc

Harmonized Standards:
EN IEC 60079-0:2018+A11:2024
EN IEC 60079-7:2015+A1:2018

EU-Type Examination Certificate: FM24ATEX0037X
Equipment protection by flameproof enclosure "d"
Equipment Group II, Category 1/2 G
Ex db IIC T6...T4 Ga/Gb

Harmonized Standards:
EN IEC 60079-0:2018+A11:2024
EN 60079-1:2014+A11:2024
EN 60079-26:2015

EU-Type Examination Certificate: FM24ATEX0037X
Equipment dust ignition protection by enclosure "t"
Equipment Group II, Category 1 D
Ex ta IIIC T200110°C Da

Harmonized Standards:
EN IEC 60079-0:2018+A11:2024
EN 60079-31:2014

9.7 China RoHS table

含有China RoHS管控物质超过最大浓度限值的部件型号列表 4051S, 4051SLT, 4051SF
List of 4051S, 4051SLT, 4051SF Parts with China RoHS Concentration above MCVs

部件名称 Part Name	有害物质 / Hazardous Substances					
	铅 Lead (Pb)	汞 Mercury (Hg)	镉 Cadmium (Cd)	六价铬 Hexavalent Chromium (Cr +6)	多溴联苯 Polybrominated biphenyls (PBB)	多溴联苯醚 Polybrominated diphenyl ethers (PBDE)
电子组件 Electronics Assembly	X	○	○	○	○	○
壳体组件 Housing Assembly	○	○	○	○	○	○
传感器组件 Sensor Assembly	X	○	○	○	○	○

本表格系依据SJ/T11364的规定而制作。

This table is proposed in accordance with the provision of SJ/T11364.

O: 意为该部件的所有均质材料中该有害物质的含量均低于GB/T 26572所规定的限量要求。

O: Indicate that said hazardous substance in all of the homogeneous materials for this part is below the limit requirement of GB/T 26572.

X: 意为在该部件所使用的的所有均质材料里，至少有一类均质材料中该有害物质的含量高于GB/T 26572所规定的限量要求。

X: Indicate that said hazardous substance contained in at least one of the homogeneous materials used for this part is above the limit requirement of GB/T 26572.

部件名称 Part Name	组装备件说明 Spare Parts Descriptions for Assemblies
电子组件 Electronics Assembly	电子线路板组件 Electronic Board Assemblies 端子块组件 Terminal Block Assemblies 升级套件 Upgrade Kits LCD 或带快速服务按钮的 LCD LCD or LCD with Quick Service Buttons
壳体组件 Housing Assembly	电子外壳 Electrical Housing
传感器组件 Sensor Assembly	传感器模块 Sensor Module



Quick Start Guide
MS-00825-0100-6201, Rev. AA
November 2025

For more information: [Emerson.com/global](https://www.emerson.com/global)

©2025 Emerson. All rights reserved.

Emerson Terms and Conditions of Sale are available upon request. The Emerson logo is a trademark and service mark of Emerson Electric Co. Rosemount is a mark of one of the Emerson family of companies. All other marks are the property of their respective owners.

The "Bluetooth" word mark and logos are registered trademarks owned by Bluetooth SIG, Inc. and any use of such marks by Emerson is under license.

ROSEMOUNT™

