

GE Infrastructure
Sensing



Model O2X1
Oxygen Transmitter

User's Manual



GE Infrastructure Sensing

Model O2X1 *Oxygen Transmitter*

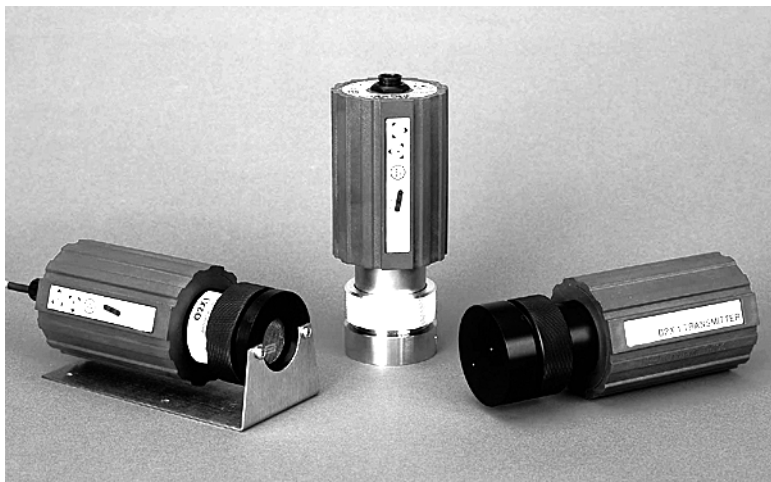

User's Manual

916-048G

September 2004



Table of Contents

Introduction	1
Mounting the Transmitter	3
Wiring the Transmitter	6
Making a Custom Transmitter Cable	6
Installing an Oxygen Sensor	9
The O2X1 Keypad	11
The O2X1 Menu Map	11
Entering and Exiting the User Program	13
Programming and Calibrating the O2X1	14
Selecting the Range	14
Trimming the Output	15
Span Gas Calibration	16
Air Calibration	18
Specifications	20
Model Number	22
Electrical Classification/Certification	23
Intrinsically Safe Installation	24
Non-Hazardous Installation	25

Warranty

Each instrument manufactured by GE Infrastructure Sensing, Inc. is warranted to be free from defects in material and workmanship. Liability under this warranty is limited to restoring the instrument to normal operation or replacing the instrument, at the sole discretion of GE Infrastructure Sensing, Inc. Fuses and batteries are specifically excluded from any liability. This warranty is effective from the date of delivery to the original purchaser. If GE Infrastructure Sensing, Inc. determines that the equipment was defective, the warranty period is:

- one year from delivery for electronic or mechanical failures
- one year from delivery for sensor shelf life

If GE Infrastructure Sensing, Inc. determines that the equipment was damaged by misuse, improper installation, the use of unauthorized replacement parts, or operating conditions outside the guidelines specified by GE Infrastructure Sensing, Inc. , the repairs are not covered under this warranty.

The warranties set forth herein are exclusive and are in lieu of all other warranties whether statutory, express or implied (including warranties or merchantability and fitness for a particular purpose, and warranties arising from course of dealing or usage or trade).

Return Policy

If a GE Infrastructure Sensing, Inc. instrument malfunctions within the warranty period, the following procedure must be completed:

1. Notify GE Infrastructure Sensing, Inc., giving full details of the problem, and provide the model number and serial number of the instrument. If the nature of the problem indicates the need for factory service, GE Infrastructure Sensing, Inc. will issue a RETURN AUTHORIZATION NUMBER (RAN), and shipping instructions for the return of the instrument to a service center will be provided.
2. If GE Infrastructure Sensing, Inc. instructs you to send your instrument to a service center, it must be shipped prepaid to the authorized repair station indicated in the shipping instructions.
3. Upon receipt, GE Infrastructure Sensing, Inc. will evaluate the instrument to determine the cause of the malfunction.

Then, one of the following courses of action will then be taken:

- If the damage is covered under the terms of the warranty, the instrument will be repaired at no cost to the owner and returned.
- If GE Infrastructure Sensing, Inc. determines that the damage is not covered under the terms of the warranty, or if the warranty has expired, an estimate for the cost of the repairs at standard rates will be provided. Upon receipt of the owner's approval to proceed, the instrument will be repaired and returned.

Introduction

The GE Infrastructure Sensing O2X1 oxygen transmitter (Figure 1 below) accurately measures oxygen content in a gas mixture at 0 to 250,000 ppmv (25%), in six ranges. It is loop-powered from a 9-28 VDC power source and provides data readings via a 4-20 mA analog output that is updated once per second. Programmed information is stored in a nonvolatile memory.

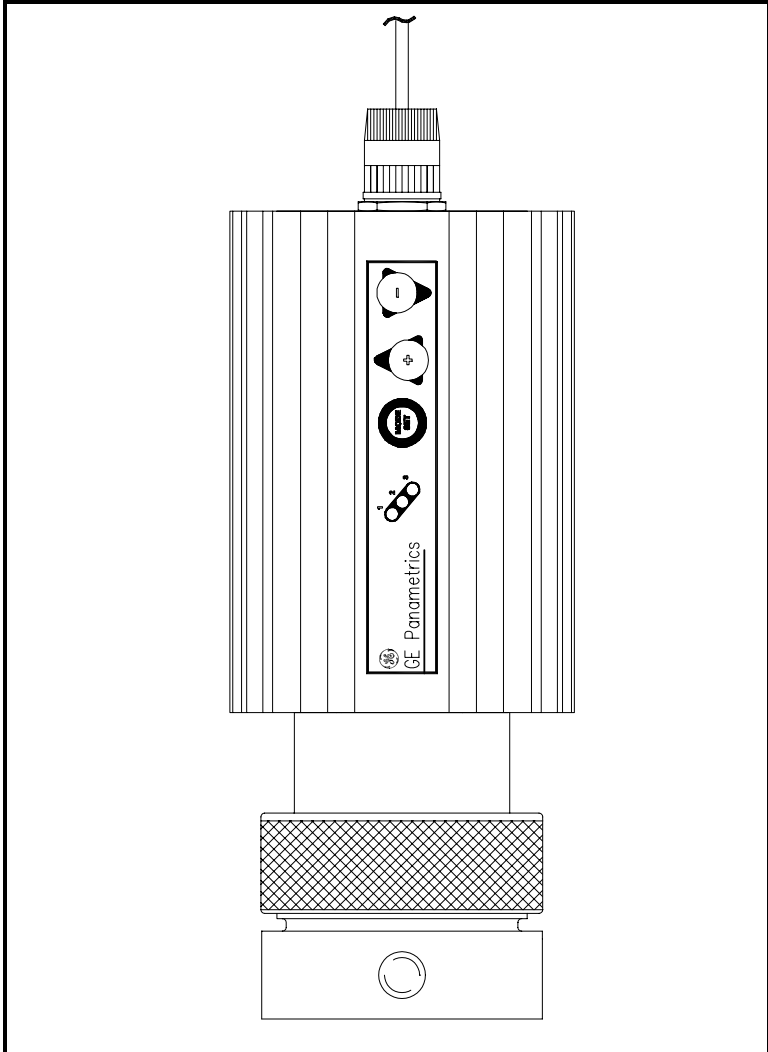

Figure 1: The O2X1 Oxygen Transmitter

Introduction (cont.)

The O2X1 is available as either an ambient air monitor or as a process unit. The process units are easily installed by completing the following steps:

- insert the oxygen sensor into the O2X1 transmitter
- connect the power to the transmitter
- calibrate the oxygen sensor
- attach the transmitter body to the sensor manifold with the knurled slip nut

A variety of oxygen sensors can be used with the O2X1, but a quick and easy calibration with ambient air must be performed upon startup whenever a new sensor is installed.

This guide shows how to properly mount, wire, calibrate, and adjust the O2X1 oxygen transmitter. Proceed to the appropriate section for information on the following topics:

Note: *The installation instructions in this manual apply only to O2X1 process units.*

- Mounting the Transmitter
- Wiring the Transmitter
- Installing an Oxygen Sensor
- Entering and Exiting the *User Program*
- Programming and Calibrating the O2X1
- Specifications
- Electrical Classification/Certification

Mounting the Transmitter

To install the O2X1 oxygen transmitter into the process or sample system, refer to Figure 2 below and proceed to the next page.

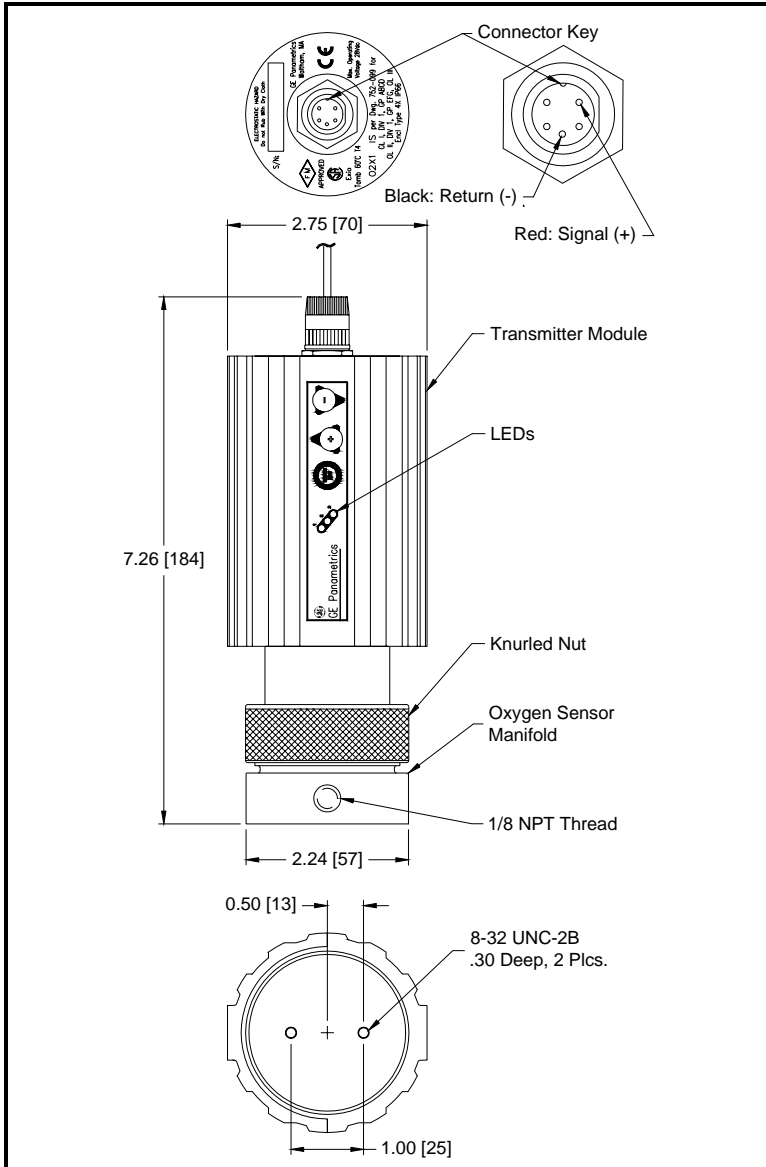

**Figure 2: Outline and Installation Drawing
(316 SS and Delrin Process Units)**

Mounting the Transmitter (cont.)

Note: *To avoid collecting condensate that may damage the oxygen sensor, mount the O2X1 in an upright position, with the sensor manifold below the electronics module.*

Install the O2X1 transmitter by completing the following steps:

1. Remove the O2X1 transmitter and the separately-packaged oxygen sensor (see Figure 3 below) from the shipping container. Keep the shipping container and packaging material for possible future use.

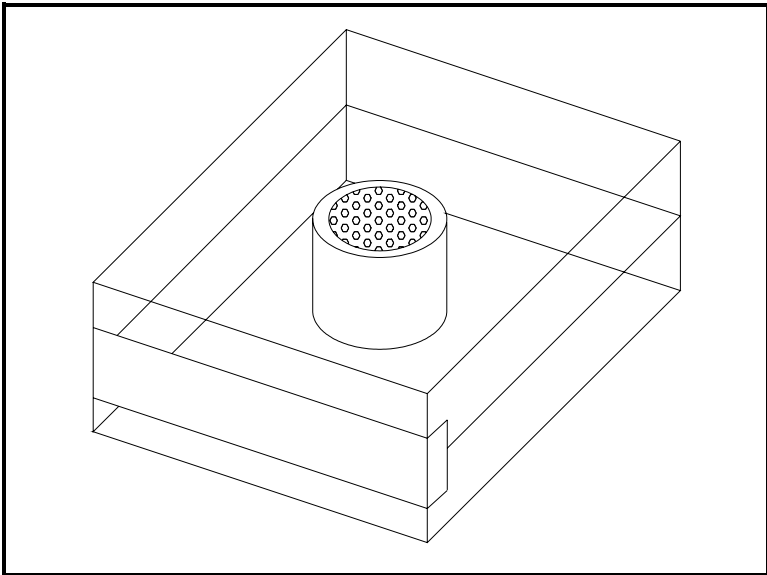

Figure 3: Packaged Oxygen Sensor

Mounting the Transmitter (cont.)

- Using Teflon tape as a sealant, connect the sample gas inlet and outlet to the 1/8" NPT ports on the sensor manifold (see Figure 4 below). Either port may be used as the inlet or the outlet; the direction of flow does not matter.

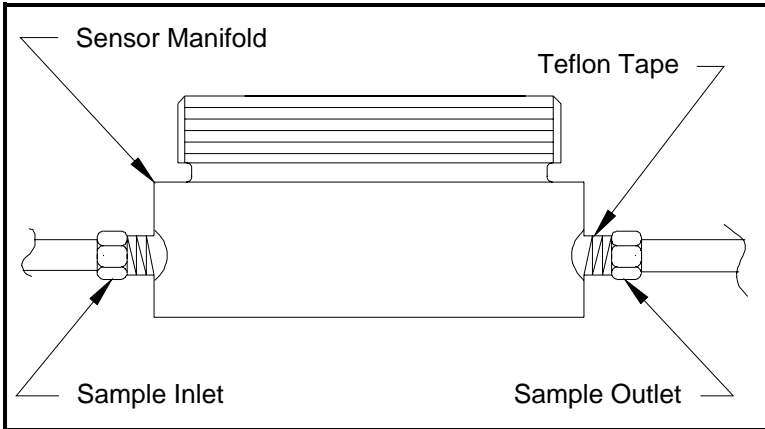

Figure 4: Sensor Manifold Installation

Wiring the Transmitter

To wire the O2X1 oxygen transmitter refer to Figure 5 on the next page and Figure 6 on page 8. Then, proceed as follows:

!WARNING!

For FM/CSA/BASIEFA certified applications, the O2X1 must be installed with a zener barrier (see Figure 5 on the next page). Also, for installations in a hazardous location, the blue OCI (5) T5 cable must be used.

1. A standard 5 ft long, two-wire cable is supplied with the O2X1. Screw the cable's five-pin connector to the mating connector on the O2X1 unit.

Note: *Longer cables are available for quotation.*

2. Connect the other end of the cable according to one of the following steps:
 - a. **No Zener Barrier:** Attach the red wire to the positive terminal of a 9-28 VDC power supply. Attach the black lead to the negative terminal of the power supply.
 - b. **With Zener Barrier:** Attach the red and black wires to the zener barrier, as shown in Figure 6 on page 8.

Making a Custom Transmitter Cable

To construct a transmitter cable longer than the one supplied with the unit (up to a maximum of 1,100 ft), refer to *Note 1* in Figure 5 on the next page and the specifications on pages 24 and 25.

Solder the two leads on one end of the cable to the connector provided by GE Infrastructure Sensing. For the pin connections on the transmitter, see Figure 2 on page 3.

Note: *The orientation of the connector depends on how the transmitter is installed. Use the connector key shown in Figure 2 on page 3 as a reference when making lead connections.*

Wiring the Transmitter (cont.)

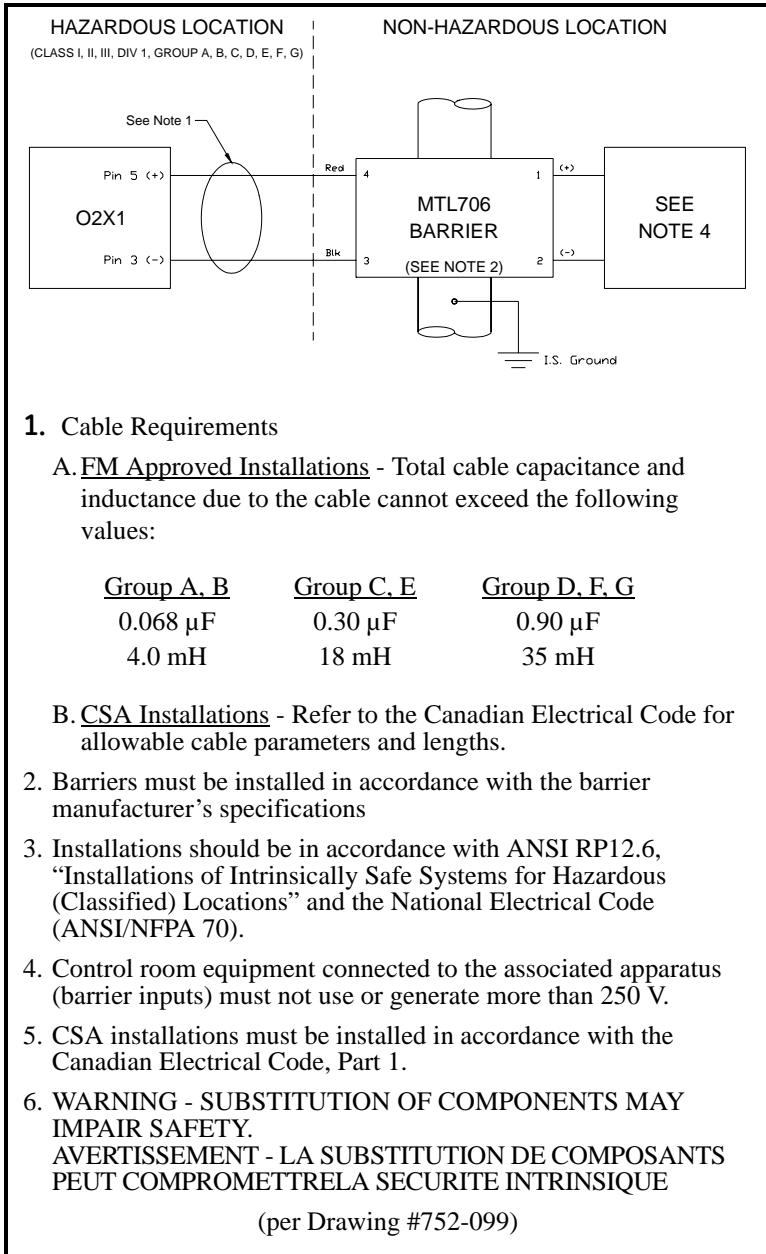
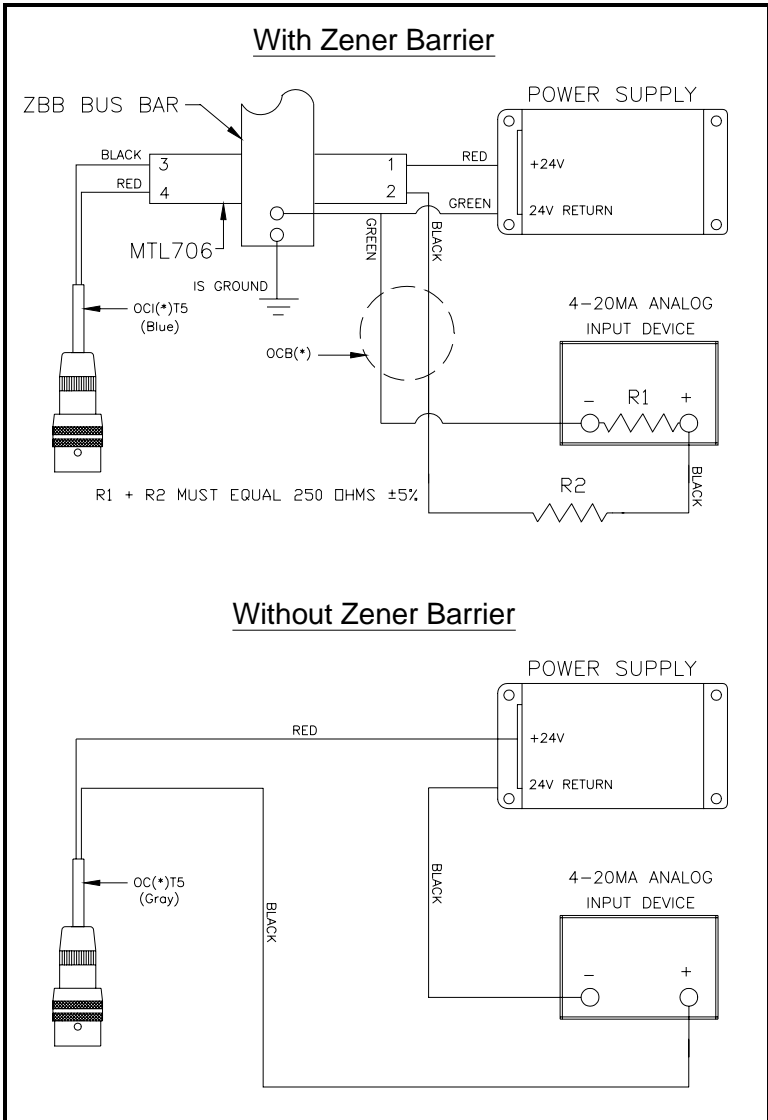

Figure 5: Typical Certification Requirements for 316 SS Process Unit Installations

Wiring the Transmitter (cont.)



Installing an Oxygen Sensor

To install a new or replacement oxygen sensor in the O2X1, refer to Figure 7 below and complete the following steps:

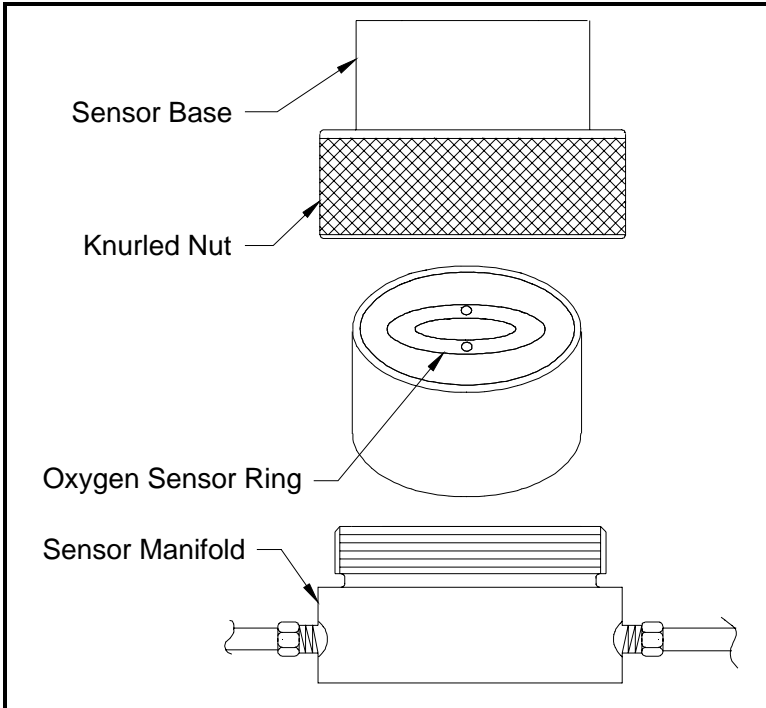

Figure 7: Oxygen Sensor Installation

1. Disconnect the power from the O2X1
2. Loosen the knurled slip nut and remove the O2X1 body from the sensor manifold. If a previous oxygen sensor is already in place, remove it now.
3. Apply power to the unit. The O2X1 initializes in about 15 seconds and then all three LEDs light momentarily.

Installing an Oxygen Sensor (cont.)

Note: *Before continuing with the installation, become familiar with the procedures for programming and calibrating the O2X1 oxygen transmitter discussed later in this manual.*

4. Trim the 4-20 mA analog output (see page 15) and set the range to 0-25% oxygen (see page 14).
5. Open the airtight package (see Figure 4 on page 5) and remove the oxygen sensor from the package. To maintain the oxygen sensor's energy level, remove the red grounding tab and **immediately** proceed to the next step.
6. Orient the sensor so that its gold-plated electrodes are facing the spring-loaded contact pins in the sensor base (see Figure 7 on the previous page). Firmly press the oxygen sensor into the sensor base on the O2X1 transmitter.
7. It is best to perform an air calibration on the new oxygen sensor at this time (see page 18). On the 0-25% oxygen scale, a properly calibrated oxygen sensor generates a current of 17.4 mA at the 4-20 mA analog output terminals.
8. Using the knurled slip nut, attach the transmitter with the calibrated oxygen sensor to the sensor manifold. Rotate the transmitter as desired and hand-tighten the knurled slip nut.
9. Begin the flow of either the process or the calibration gas. The analog output reading should begin to drop as the oxygen sensor adjusts to the reduced oxygen level. During this time, reset the range as required.
10. For improved accuracy in the ppm oxygen ranges, a span gas calibration should now be performed (see page 16).







IMPORTANT: *Sensor life is dependent on the application. High oxygen concentrations and/or contaminants such as acid gases shorten sensor life.*

The O2X1 Keypad

The O2X1 keypad consists of three keys and three light-emitting diodes (LEDs), as shown in see Figure 1 on page 1. Table 1 below lists all of the keypad components and shows the symbols used to represent them in this document.

Note: *During programming, all keystrokes must be completed within 60 seconds of the previous keystroke.*

Table 1: The O2X1 Keys and LEDs

Symbol	Component Name
	Mode Set Key
	Up Arrow Key
	Down Arrow Key
	LED #1
	LED #2
	LED #3

The O2X1 Menu Map

As an aid in navigating through the *User Program*, a complete *Menu Map* of the program is presented in Figure 8 on the next page. Please refer to this figure as needed, while programming the O2X1 transmitter.

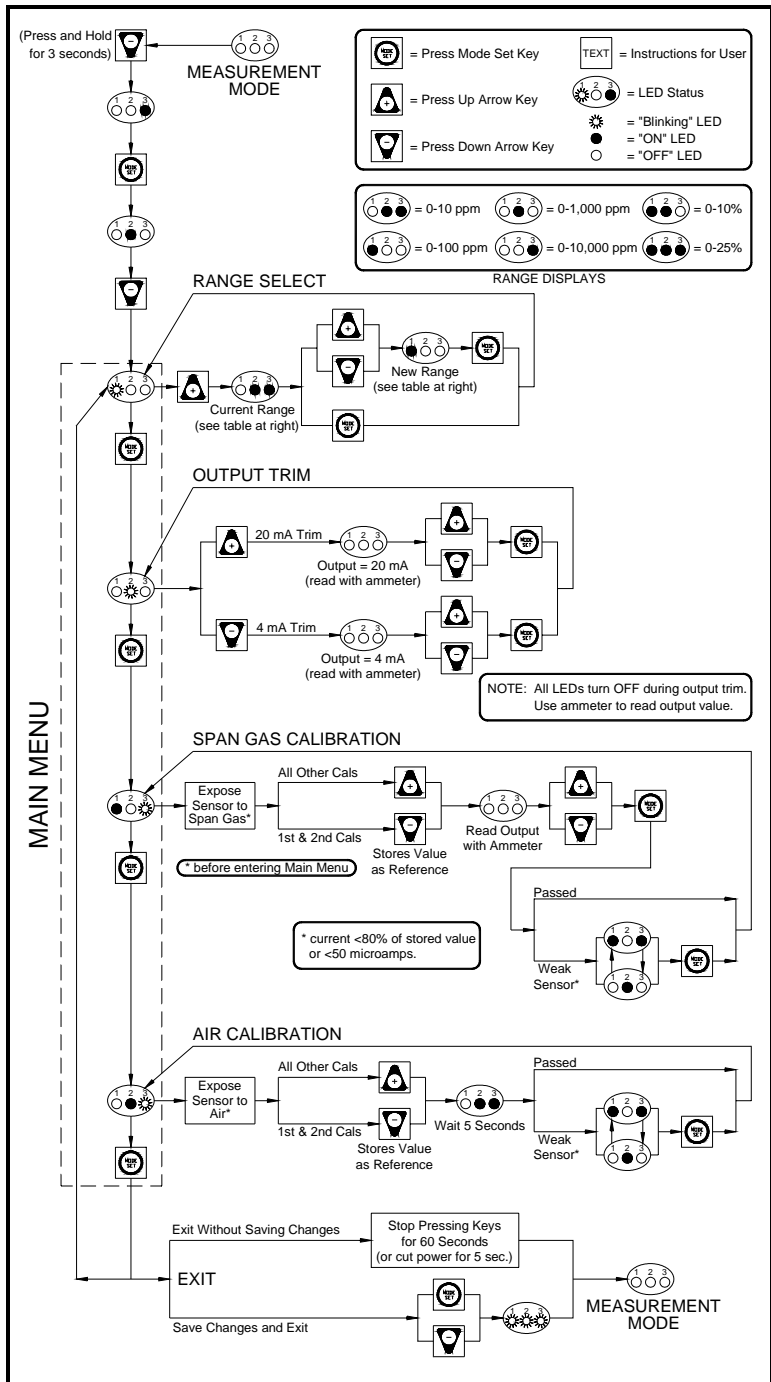











Figure 8: O2X1 Menu Map

Entering and Exiting the User Program

Table 2 below shows how to use the O2X1 keypad to navigate through the *User Program*.

Table 2: O2X1 Menu Navigation

Operation	Key/LED Sequence
Enter the Main Menu	<ol style="list-style-type: none"> 1. Press and hold the  key until  3 turns ON (about 3 seconds). 2. Press the  key, and  2 turns ON. 3. Press the  key, and  1 starts blinking. This indicates that you have entered the <i>Main Menu</i>. <p>Note: <i>The O2X1 operates on a 4-20 mA loop current, which varies as the LEDs turn ON and OFF. Therefore, do not take any measurements while in the User Program.</i></p>
Move to next item in Main Menu	Press the  key until the appropriate LED status is obtained (see Figure 8 on page 12).
Save changes and exit	<p>While in the <i>Main Menu</i>, press and hold down both the  and  keys until all three LEDs begin blinking. Then release the keys. After your changes have been saved, all three LEDs will turn OFF.</p> <p>Note: <i>If any of the LEDs are still blinking, you are still in the Main Menu.</i></p>
Exit without saving changes	Stop pressing keys and wait until all three LEDs turn OFF (about 60 seconds), or disconnect the power for at least 5 seconds.

The O2X1 *User Program* consists of a *Main Menu* and four submenus. A complete *Menu Map* of the program is shown in Figure 8 on page 12.

Programming and Calibrating the O2X1

Upon startup, a five-step adjustment and calibration procedure must be performed on the O2X1:

1. Select the desired measurement range.
2. Trim the low (4 mA) and high (20 mA) analog outputs.
3. Upon installation of a new oxygen sensor, calibrate the unit with air for either a ppm or % sensor.
4. For ppm sensors only, purge the sensor with a low ppm oxygen gas.
5. For all subsequent calibrations, use a span gas that is appropriate for the sensor and range selected.

To begin the above tasks, proceed to the next section.

Selecting the Range









1. Scroll through the *Main Menu* until  1 is blinking, and press the  key to display the current range. See Table 3 below to determine the current range from the status of the LEDs.

Table 3: LED Range Codes

 1	 2	 3	Range
OFF	ON	ON	0-10 ppm
ON	OFF	OFF	0-100 ppm
OFF	ON	OFF	0-1,000 ppm
OFF	OFF	ON	0-10,000 ppm
ON	ON	OFF	0-10%
ON	ON	ON	0-25%

2. To select the desired range, press the  or  key to scroll through the available options until the desired range is displayed via the LED codes.
3. When done, press the  key. The blinking of  1 indicates that you have returned to the *Main Menu*.



Trimming the Output

To trim the analog output, calibrate the low (4 mA) end of the output then the high (20 mA) end of the output.





IMPORTANT: *The low and high adjustments interact with each other. Therefore, recheck the calibration after the procedure has been completed.*

Preparing to Trim the Output:





Prepare to trim the analog output as follows:

1. Connect an ammeter in series with the positive O2X1 power supply lead, to monitor the analog output.
2. Enter the *Main Menu* as described in Table 2 on page 13.
3. Press the  key repeatedly until  2 blinks. This is the beginning of the *Output Trim* submenu.

Trimming the Output Low (4 mA) End:

1. Press the  key. All LEDs turn OFF and the analog output is driven to approximately 4 mA.
2. Press the  or  key to adjust the output up or down, until it equals 4.00 ± 0.01 mA.
3. When done, press the  key.  2 blinks, indicating that you are back at the *Main Menu*.

Trimming the Output High (20 mA) End:

1. Press the  key. All LEDs turn OFF and the analog output is driven to approximately 20 mA.
2. Press the  or  key to adjust the output up or down, until it equals 20.00 ± 0.01 mA.
3. When done, press the  key.  2 blinks, indicating that you are back at the *Main Menu*.

Trimming the Output (cont.)

Completing the Trim Procedure:

1. Repeat both the low end and high end analog output trimming steps until no further trimming adjustments are required.
2. Exit the *Main Menu* and *Save* your changes, as described in Table 2 on page 13.

Span Gas Calibration



Before entering the *Main Menu*, use a low oxygen content purge gas to prepare the O2X1. Then, start the flow of the span gas to the sensor and wait until the output reading is stable. After initial exposure to the calibration gas, obtaining a stable reading takes a few seconds in the higher ranges (0-1,000 ppm and above) and a minute or more in the lower ranges (0-10 and 0-100 ppm). For accurate calibration, the span gas should have an oxygen content of 70-90% of the range being calibrated.

To perform the calibration, complete the following steps:









1. Use the equation below to calculate the expected mA output that corresponds to the known oxygen content of the span gas:

$$4.0 + 16.0 \times \frac{\text{Span Gas ppm}}{\text{Full Range ppm}} = \text{mA Output}$$



For example, if the span gas contains 80 ppm oxygen and the 0-100 ppm range is being calibrated, the analog output should equal $4 + 16 \times (80/100) = 16.8$ mA.

2. Start the flow of span gas to the sensor, and allow the 4-20 mA output reading to stabilize.
3. After the reading has stabilized, enter the *Main Menu* as described on page 13.
4. Press the  key until  1 is ON and  3 is blinking.

Span Gas Calibration (cont.)

5. For the first two calibrations after installing the transmitter, use the  key to store the calibration value in memory as a reference to detect a weak sensor. For all subsequent calibrations, press the  key to reference this value against the one stored in memory. All LEDs turn OFF after the key is pressed.
6. While using an ammeter to monitor the 4-20 mA output, press the  or  key to adjust the analog output until the reading equals the value calculated in Step 1 on the previous page.
7. When done, press the  key. If the calibration was successful,  1 should be ON and  3 should be blinking. At this point, the mA output is equal to the calibration setting of Step 5 above and **must be saved**. Save the calibration by holding down both the  and  keys until all three LEDs flash and then turn OFF.

Note: *The second calibration after installation should be performed within 1-2 days of the first calibration.*

Note: *If  1 and  3 blink alternately with  2, the sensor is weak and sensor failure may be imminent.*

IMPORTANT: *To detect a weak sensor, the same span gas that was used for the first two calibrations must be used for all subsequent calibrations.*











If the sensor is weak and a replacement sensor is not immediately available, repeat the calibration using the  key in Step 5 above. This stores a weaker sensor calibration value into memory for temporary use. However, be aware that sensor drift may be increasing, and accuracy cannot be guaranteed. The sensor should be replaced as soon as possible.

Air Calibration

An air calibration, as described below, is always recommended upon installation of a new oxygen sensor. However, because of the non-linearity of the oxygen sensor, a span gas calibration (see page 16) should also be performed to ensure more accurate readings in the ppm ranges.

Caution!

The useful life of ppm sensors will be extended by minimizing exposure of the sensor to air.

1. Expose the oxygen sensor to ambient air for about two minutes.
2. In the *Main Menu*, press the  key until  2 is ON and  3 is blinking.
3. For the first two calibrations after installing the transmitter, use the  key to store the sensor current value in memory as a reference. For all subsequent calibrations, press the  key to reference this new value against the one stored in memory. After pressing the key,  2 and  3 will come on for about five seconds, until the calibration is complete.
4. Reconnect the O2X1 transmitter to the process and switch back to a calibration gas of low oxygen content.
5. When  2 is ON and  3 is blinking, you are back at the *Main Menu*. The new calibration **must** be saved by holding down both the  and  keys until all three LEDs flash and then turn OFF.

Air Calibration (cont.)

Note: *If ✪1 and ✪3 blink alternately with ✪2, the calibration was rejected because the sensor current was less than 50 μ A. The sensor is weak and sensor failure may be imminent - replace the sensor as soon as possible.*

Note: *The second calibration after installation should be performed within 1-2 days of the first calibration.*

If the sensor is weak and a replacement sensor is not immediately available, repeat the calibration using the  key in Step 3 on the previous page. If this reading is still less than 50 μ A, the reading cannot be stored and the sensor must be replaced immediately.

Specifications

ppm Sensor Measurement Ranges (Field-Programmable):

0–10 ppmv O₂ (316 SS package only)
0–100 ppmv O₂
0–1,000 ppmv O₂
0–10,000 ppmv O₂

% Sensor Measurement Ranges (Field-Programmable):

0–1% O₂
0–10% O₂
0–25% O₂

Accuracy:

±1% of span at calibration point for all ranges, except ±2% of span at the calibration point for the 0–10 ppmv range (316 SS package only)

Repeatability:

±1% of span or ±2% of span for 0–10 ppmv range (316 SS package only)

Resolution:

±0.1% of span

Linearity:

±2% of span

Operating Temperature:

0–45°C (32–113°F)

Ambient Temperature Effect:

±3% of reading over operating temperature range

Specifications (cont.)

Sample Pressure:

atmospheric (during operation and calibration)

Atmospheric Pressure Effect:

$\pm 0.13\%$ of reading per mm Hg (directly proportional to absolute pressure). During calibration, pressure and flow rate must be kept constant.

Process Connection:

316 SS & Delrin process units: 1/8" NPT inlet and outlet
ambient air monitoring units: none

Sample Flow Rate:

1.0 SCFH (500 cc/min) recommended

Response Time:

90% step change with standard sensors:

10 seconds from 1–12 ppm O₂

10 seconds from 12–1 ppm O₂

15 seconds from 5–10,000 ppm O₂

10 seconds from 10,000–5 ppm O₂

22 seconds from 0.1–21% O₂

16 seconds from 21–0.1% O₂

Process Wetted Materials

316 SS Process Unit: 316 SS, Viton, Teflon

Delrin Process Unit: Delrin, Viton, Teflon

Ambient Air Monitoring Unit: Delrin, Viton, Teflon

Model Number

The model number for the O2X1 oxygen transmitter is constructed as follows:

O2X1 - B C

Where, **B (Sensor)** =

- 0 - no sensor
- 1 - standard ppm sensor
- 2 - acid ppm sensor
- 3 - standard percent sensor
- 4 - acid percent sensor

Where, **C (Package)** =

- 0 - standard stainless steel
- 1 - Delrin plastic
- 2 - ambient air monitor
- S - special

For example, an O2X1 with a standard percent sensor and a Delrin plastic package would have the following model number:

O2X1-31

Electrical Classification/Certification

Weatherproof (Process Units Only):

NEMA 4X, IP66

Intrinsically Safe (316 SS Units Only):

Class I, II, III, Div. 1, Groups A, B, C, D, E, F, G;
FM J.I.2D6A6.AX (3610); CSA LR 44204

II 1 G EEx ia IIC T4 (-20° to +60°C)
BAS01ATEX1094 X

CE European Union Compliance:

Note: *See the Declaration of Conformity and ATEX Compliance certificates at the back of this manual for additional information.*

All O2X1 package options comply with EMC Directive 89/336/EEC and Low-Voltage Directive 73/23/EEC (Installation Category II, Pollution Degree 2).

For EN 61000-4-3, the O2X1 meets performance criteria A and, in a limited number of frequencies, performance criteria B per EN 61326.

IMPORTANT: *For CE compliance, the O2X1 cable must be shielded and the shield must be terminated at the supply end.*

Intrinsically Safe Installation

Intrinsically safe installations require the use of an MTL706 Zener barrier.

Power Requirements with an MTL706:

24–28 VDC, at 50 mA

Cable:

OCI()T5 in hazardous area:* blue, 2-conductor twisted-pair with connector, 22 AWG, 1,100 ft maximum length
(* = length in ft)

OCB() in nonhazardous (safe) area:*
3-conductor, 22 AWG, 0.04 ohms/ft

Note: *Cable requirements for certified installations must also comply with Note 1 in Figure 5 on page 7.*

Output:

Total load must equal $250 \Omega \pm 5\%$

Non-Hazardous Installation

Non-Hazardous installations do not require the use of an MTL706 Zener barrier.

Power Requirement:

9–28 VDC, loop-powered, 0.6 W max.

Cable:

OC(*)T5: gray, 2-conductor twisted pair with connector,
22 AWG, 0.04 ohms/ft (* = length in ft)

Output:

Max. Load (ohms) = $[40 \times (\text{PSV} - 8)] - \text{RC}$
 PSV = Power Supply Voltage in VDC
 RC = Cable Resistance
 (22 AWG cable has 0.04 ohms/ft)

Example:

Given a 24 VDC power supply and a 1,000 ft, 22 AWG cable

$\text{RC} = 1,000 \text{ ft.} \times 0.04 \text{ ohms/ft} = 40 \text{ ohms}$
 Max. Load = $[40 \times (24 - 8)] - 40 = 600 \text{ ohms}$

Index

A

Air Calibration 1-18

C

Cable, Custom. 1-6

Calibration

 Ambient Air 1-18

 Five-Step Procedure 1-14

 Span Gas 1-16

CE Compliance 1-23

Certification

 Data 1-23

 Drawing 1-7

E

Electrical Classification 1-23

I

Installation Specifications

 Intrinsically Safe 1-24

 Non-Hazardous 1-25

K

Keypad 1-11

L

LED's 1-11

M

Menu Map 1-12

Model Number 1-22

O

Outline and Installation Drawing 1-3

Output, Trimming 1-15

Oxygen Sensor, Installing 1-9

R

Range, Selecting 1-14

Index (cont.)

S

Sensor Manifold, Installing	1-5
Span Gas Calibration	1-16
Specifications	
Hazardous Locations	1-24
Non-Hazardous Locations	1-25
Transmitter	1-20

U

Unit Types	1-2
User Program	
Entering	1-13
Exiting	1-13
Navigating	1-13

W

Wiring Diagram	1-8
Wiring the Transmitter	1-6

We,

Panametrics Limited
Shannon Industrial Estate
Shannon, County Clare
Ireland

declare under our sole responsibility that the

O2X1 Oxygen Transmitter

to which this declaration relates, are in conformity with the following standards:

- EN 50014:1997+A1+A2:1999
- EN 50020:1994
- EN50284:1999
- II 1 G EEx ia IIC T4; BAS01ATEX1094 X
Baseefa (2001) Ltd/EECS, Buxton, SK17 9JN, UK
- EN 50104:1998
Deviation from Standard: unit not tested from -10°C to 0°C
- EN 61326:1998, Class A, Annex A, Continuous Unmonitored Operation
(For EN 61000-4-3, the O2X1 meets performance Criteria A, and in a limited number of frequencies, performance Criteria B per EN 61326.)
- EN 60529:1991+A1:2000
IP66

following the provisions of the 89/336/EEC EMC Directive and the 94/9/EC ATEX Directive.

The units listed above and any ancillary sample handling systems supplied with them do not bear CE marking for the Pressure Equipment Directive, as they are supplied in accordance with Article 3, Section 3 (sound engineering practices and codes of good workmanship) of the Pressure Equipment Directive 97/23/EC for DN<25.

Shannon - July 1, 2003

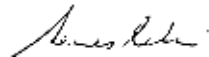

Mr. James Gibson
GENERAL MANAGER



CERT-DOC-H1



August 2004)

Nous,

Panametrics Limited
Shannon Industrial Estate
Shannon, County Clare
Ireland

déclarons sous notre propre responsabilité que les

O2X1 Oxygen Transmitter

relatif à cette déclaration, sont en conformité avec les documents suivants:

- EN 50014:1997+A1+A2:1999
- EN 50020:1994
- EN50284:1999
- II 1 G EEx ia IIC T4; BAS01ATEX1094 X
Baseefa (2001) Ltd/EECS, Buxton, SK17 9JN, UK
- EN 50104:1998
Deviation from Standard: unit not tested from -10°C to 0°C
- EN 61326:1998, Class A, Annex A, Continuous Unmonitored Operation
(For EN 61000-4-3, the O2X1 meets performance Criteria A, and in a limited number of frequencies, performance Criteria B per EN 61326.)
- EN 60529:1991+A1:2000
IP66

suivant les règles de la Directive de Compatibilité Electromagnétique 89/336/EEC et d'ATEX 94/9/EC.

Les matériels listés ci-dessus ainsi que les systèmes d'échantillonnages pouvant être livrés avec, ne portent pas le marquage CE de la directive des équipements sous pression, car ils sont fournis en accord avec la directive 97/23/EC des équipements sous pression pour les DN<25, Article 3, section 3 qui concerne les pratiques et les codes de bonne fabrication pour l'ingénierie du son.

Shannon - July 1, 2003

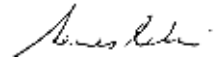

Mr. James Gibson
DIRECTEUR GÉNÉRAL



CERT-DOC-H1



August 2004)

Wir,

Panametrics Limited
Shannon Industrial Estate
Shannon, County Clare
Ireland

erklären, in alleiniger Verantwortung, daß die Produkte

O2X1 Oxygen Transmitter

folgende Normen erfüllen:

- EN 50014:1997+A1+A2:1999
- EN 50020:1994
- EN50284:1999
- II 1 G EEx ia IIC T4; BAS01ATEX1094 X
Baseefa (2001) Ltd/EECS, Buxton, SK17 9JN, UK
- EN 50104:1998
Deviation from Standard: unit not tested from -10°C to 0°C
- EN 61326:1998, Class A, Annex A, Continuous Unmonitored Operation
(For EN 61000-4-3, the O2X1 meets performance Criteria A, and in a limited number of frequencies, performance Criteria B per EN 61326.)
- EN 60529:1991+A1:2000
IP66

gemäß den Europäischen Richtlinien, Niederspannungsrichtlinie EMV-Richtlinie
Nr.: 89/336/EG und ATEX Richtlinie Nr. 94/9/EG

Die oben aufgeführten Geräte und zugehörige, mitgelieferte Handhabungssysteme tragen keine CE-Kennzeichnung gemäß der Druckgeräte-Richtlinie, da sie in Übereinstimmung mit Artikel 3, Absatz 3 (gute Ingenieurpraxis) der Druckgeräte-Richtlinie 97/23/EG für DN<25 geliefert werden.

Shannon - July 1, 2003

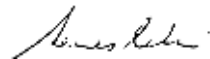

Mr. James Gibson
GENERALDIREKTOR



CERT-DOC-H1



August 2004)

We,

GE Infrastructure Sensing, Inc.
1100 Technology Park Drive
Billerica, MA 01821-4111
U.S.A.

as the manufacturer, declare under our sole responsibility that the product

O2X1 Oxygen Transmitter

to which this document relates, in accordance with the provisions of ATEX Directive 94/9/EC Annex II, meets the following specifications:

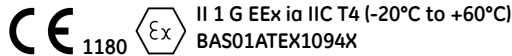

Furthermore, these additional requirements and specifications apply to the product:

- Having been designed in accordance with EN 50014, EN 50020, and EN 50284, the product meets the fault tolerance requirements of electrical apparatus for category “ia”.
- The product is an electrical apparatus and must be installed in the hazardous area in accordance with the requirements of the EC Type Examination Certificate. The installation must be carried out in accordance with all appropriate international, national and local standard codes and practices and site regulations for flameproof apparatus and in accordance with the instructions contained in the manual. Access to the circuitry must not be made during operation.
- Only trained, competent personnel may install, operate and maintain the equipment.
- The product has been designed so that the protection afforded will not be reduced due to the effects of corrosion of materials, electrical conductivity, impact strength, aging resistance or the effects of temperature variations.
- The product cannot be repaired by the user; it must be replaced by an equivalent certified product. Repairs should only be carried out by the manufacturer or by an approved repairer.
- The product must not be subjected to mechanical or thermal stresses in excess of those permitted in the certification documentation and the instruction manual.
- The product contains no exposed parts which produce surface temperature infrared, electromagnetic ionizing, or non-electrical dangers.
- As a special condition for safe use, the product must not be used to measure oxygen concentrations greater than 21%.





USA

1100 Technology Park Drive
Billerica, MA 01821-4111
Web: www.gesensing.com

Ireland

Shannon Industrial Estate
Shannon, County Clare
Ireland

