

An Automated High Precision Saturation/Dilution Calibration System for Trace Moisture Sensors

The paper discusses the physical construction and operating principles of this saturation/dilution type calibration system for water vapor in a nitrogen carrier gas used for the purpose of trace moisture sensor calibration. The system generates known moisture standards, allows for settling time, takes readings from sensors, records sensor readings and creates data tables. The data tables are either loaded into “smart” probes with on-board non-volatile memory and/or printed as data sheets provided to customers so that calibration data may be inputted into analyzer electronics. The system is capable of calibrating 128 aluminum oxide moisture sensor probes per week, over a range of -80°C to $+10^{\circ}\text{C}$ dew/frost point temperature. The system is traceable to the National Institute of Standard and Technology (NIST). Each aluminum oxide moisture probe has a dedicated channel for reading the signal from the probe speeding data acquisition time. A chilled mirror hygrometer is used as a traceable transfer standard.

The heritage design, in operation since the early 1980's, is upgraded with a modern data acquisition, computer controls, data historian, human-machine-interface, and report generation based around National Instruments LabView measurement and automation software. The newly automated system provides faster system throughput and more diagnostic information about calibration performance than the heritage systems. In addition, the system can provide local and remote operator alarms should errors in calibration system operation be detected during the calibration run.



Various aluminum oxide moisture probes that can be calibrated in the described system

Introduction

One of the major challenges, which every manufacturer of measurement equipment must face, is the calibration of the equipment against a secondary standard on a production line basis while maintaining strict quality control and quality assurance. As the number of instruments or devices, which must be calibrated increases, so does the challenge. Every effort must be made to assure consistent accuracy and repeatability of calibration as throughput increases.

GE manufactures process-oriented hygrometers, which use aluminum oxide moisture sensors. The aluminum oxide moisture sensor's basic construction is shown in the graphic. The aluminum oxide moisture sensor is a transducer, which responds to the vapor pressure of water in the medium to which it is exposed, either gas phase or liquid phase. Water molecules diffuse through the porous gold layer of the sensor and into the aluminum oxide dielectric layer of the sensor.

Because the water molecule is a polar molecule, it adsorbs to the pore walls of the AlO_2 layer, thereby changing the dielectric of the sensor.



The popularity of the aluminum oxide-based hygrometer among process industries has increased by several orders of magnitude since its introduction in the 1960's. Thus the development of a sophisticated calibration system capable of calibrating a large number of moisture probes in a single run is required to meet customer demand for new moisture probes and provide capacity for customer return probes for periodic recalibration. This transducer must be calibrated against a secondary standard. The latest system design upgrades the automation of the system to provide faster thru-put, more data, better control, and better data manipulation while keeping the basis for the moisture generation calibration gas on the proven double-dilution system. The system is also scalable as a stand-alone system that can be replicated easily and provided to global production and service locations, thus providing customers with regionally located turn-around for their service needs.



Aluminum Oxide Moisture Sensor Construction

The Calibration System

The calibration system, against which GE aluminum oxide moisture sensor probes are calibrated, operates on the principal of saturation of a gas with water vapor, and then dilution of that saturated gas with dry gas to achieve a final mixture containing a known concentration of water vapor. Calibration of the moisture sensor is accomplished by exposing the probe to a generated carrier gas/water vapor mixture and recording the probe's electrical

impedance. The volumetric mixing ratio of the gas/water vapor mixture is then altered and the process is repeated. The process of calibration consists of two main sections.

1. Production of the carrier gas/water vapor mixture
2. Data acquisition, storage and reduction

Shown below is a block diagram of the calibration system. Gaseous nitrogen is withdrawn from a large tank of liquid nitrogen and transported via a single section of electro-polished, orbital-welded 316SS tubing into the calibration laboratory. Although the theoretical frost point of the nitrogen at this point is equivalent to the boiling point of nitrogen (-198°C), due to trace moisture ingress from various sources (transportation from the gas supplier, tank refilling, etc.), its frost point temperature is actually -85°C or less at 85 to 95 psig (5.9 to 6.6 bar) pressure. The pressure of the nitrogen is reduced to ambient pressure, which further reduces the frost point to approximately -95°C. The dry nitrogen then travels through a chamber, which contains several "standard" aluminum oxide moisture sensor probes. These standard probes have been previously calibrated in a laboratory, which is independent of the facility being described here. They are used to assure that the nitrogen entering the calibration system does in fact contain a moisture concentration, which is insignificant compared to the final mixture that is being generated. The dry gas then enters the moisture generation system.



Aluminum Oxide Moisture Probe Calibration System

Dry gas stream is here split into two parts. One part remains dry while the other part is saturated with water vapor by passing it through a large packed tower containing distilled water. The tower is maintained at a constant temperature of 15.2°C and a constant pressure of 20.7 psia (244Kpa). Temperature of saturation is monitored by a laboratory thermometer, which has a NIST traceable calibration and is accurate to within ±0.1°C. Pressure of saturation is monitored by a pressure transducer regularly calibrated against a pressure gauge with an NIST traceable accuracy of ±0.05 psi. This gauge is also used to calibrate transducers, which monitor the pressure in the calibration tanks. The saturated gas mixture will produce a gas mixture with a dew point of 10°C ±0.1°C when the pressure is reduced to one atmosphere.

The 10°C dew point gas exits the saturator section of the calibration system and enters the dilution section. To produce dew/frost point temperatures above -50°C, only one dilution stage is necessary. Frost point generation below -50°C requires two-stage dilution. Each of the five flow control valves used in the dilution stage of the calibration system is of the thermal mass type and the calibration of each is traceable to NIST. Their rated accuracy is ± 2% of reading. These flow control valves consist of two units, a flow sensor and an automatic controller with control valve. Output of the flow sensor goes to a comparator, which automatically adjusts the control valve to deliver the quantity of dry or wet gas required to produce the desired final mixture.

The diagram shows the flow mixing system principal for the various combinations of “wet” and “dry” gas flowmeters used to generate carrier gas/water vapor mixtures equivalent to various dew/frost point temperatures. The table below shows the flowrates for the respective valves to achieve dew/frost set points.

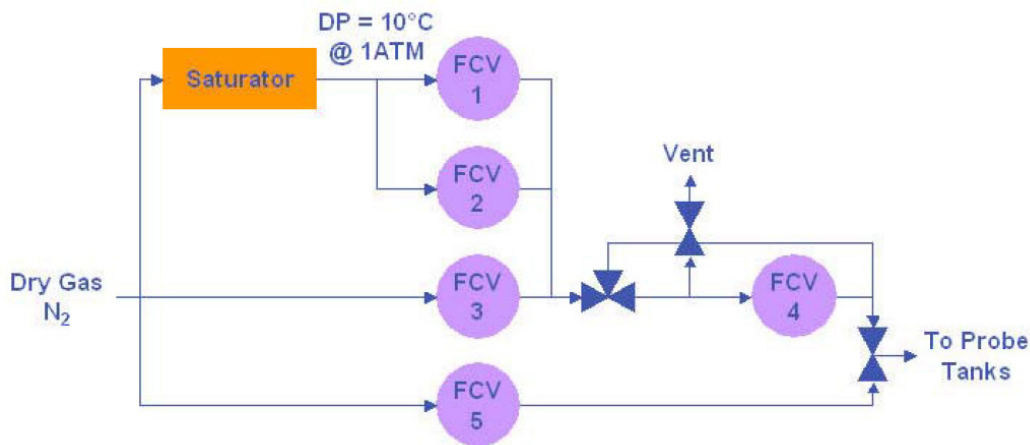

FCV-1	0-500 SCCM Wet Nitrogen
FCV-2	0-5000 SCCM Wet Nitrogen
FCV-3	0-5000 SCCM Dry Nitrogen
FCV-4	0-500 SCCM Mixture
FCV-5	0-15000 SCCM Dry Nitrogen

Flow Block Diagram

Flowrates & Accuracies for Generation of Dew/Frost Point Temperatures			
Dew/Frost Point	Flowmeter(s) in Use	Flowrate (cc/min)	Calculated Dew/Frost Point Accuracy (°C)
None (System Dry-Down)	FCV-3	4900	-
	FCV-5	15000	
10°C	FCV-2	4854	+/- 0.1
0°C	FCV-2	4854	+/- 0.2
	FCV-3	4900	
-10°C	FCV-2	4029	+/- 0.3
	FCV-5	15000	
-20°C	FCV-2	1380	+/- 0.3
	FCV-5	15000	
-30°C	FCV-1	480	+/- 0.3
	FCV-5	15000	
-40°C	FCV-1	159	+/- 0.3
	FCV-5	15000	
-50°C	FCV-1	48	+/- 0.4
	FCV-5	15000	
-60°C	FCV-1	159	+/- 0.3
	FCV-3	4900	
	FCV-4	433	
	FCV-5	15000	
-70°C	FCV-1	48	+/- 0.4
	FCV-3	4900	
	FCV-4	337	
	FCV-5	15000	
-80°C	FCV-1	48	+/- 0.4
	FCV-3	4900	
	FCV-4	69	
	FCV-5	15000	

The accuracy of the calibration system varies with the generated dew point, as shown in the table. These accuracy estimates were obtained from an error analysis of the moisture mixing system, given in the Appendix of this paper. The overall accuracy of the calibration system is better than $\pm 0.4^{\circ}\text{C}$ dew/frost point.

The outlet of the dilution stage of the calibration system is routed to the calibration tank capable of holding 128 probes. Each system can support up to 3 calibration tanks providing an overall capacity of 384 probes. Equilibrium conditions in each tank during calibration are assured by random sampling of the impedance of probes from each of the three tanks. These probes are continuously monitored at each generated dew/frost point temperature until the change in impedance becomes within the error of the A-D converter.



Chilled Mirror Hygrometer

The final check of the system is a condensation type hygrometer (also known as a chilled mirror hygrometer). This hygrometer is a Model OPTICA/1311-XR manufactured by GE. The condensation hygrometer is located at the end of the calibration chain, downstream of the probe tanks. The condensation hygrometer monitors the entire system not only to confirm the water vapor content of the generated mixture, but also to compensate for the possibility of minute system leaks, which can bias the generated volume ratio. The condensation hygrometer has a specified accuracy of +/- 0.15°C and a range of -80°C to +20°C dew/frost point temperature. Typical agreement of the condensation hygrometer with the generated calibration mixture is shown in the table below. The variation of these generated dew points from those shown in the previous table is within the accuracy tolerance of the specified accuracy of the condensation hygrometer.

Typical Agreement Between Generated Dew/Frost Point Temperatures & Chilled Mirror Hygrometer Readings	
Generated D/F PT, °C	D/F PT, Chilled Mirror Hygrometer, °C
9.63	9.61
-0.33	-0.26
-10.31	-10.19
-20.30	-20.08
-30.29	-29.95
-40.28	-40.72
-50.33	-50.70
-60.23	-60.05
-70.21	-70.35
-80.16	-80.04

Moisture Calibration System Single Manifold Block Diagram

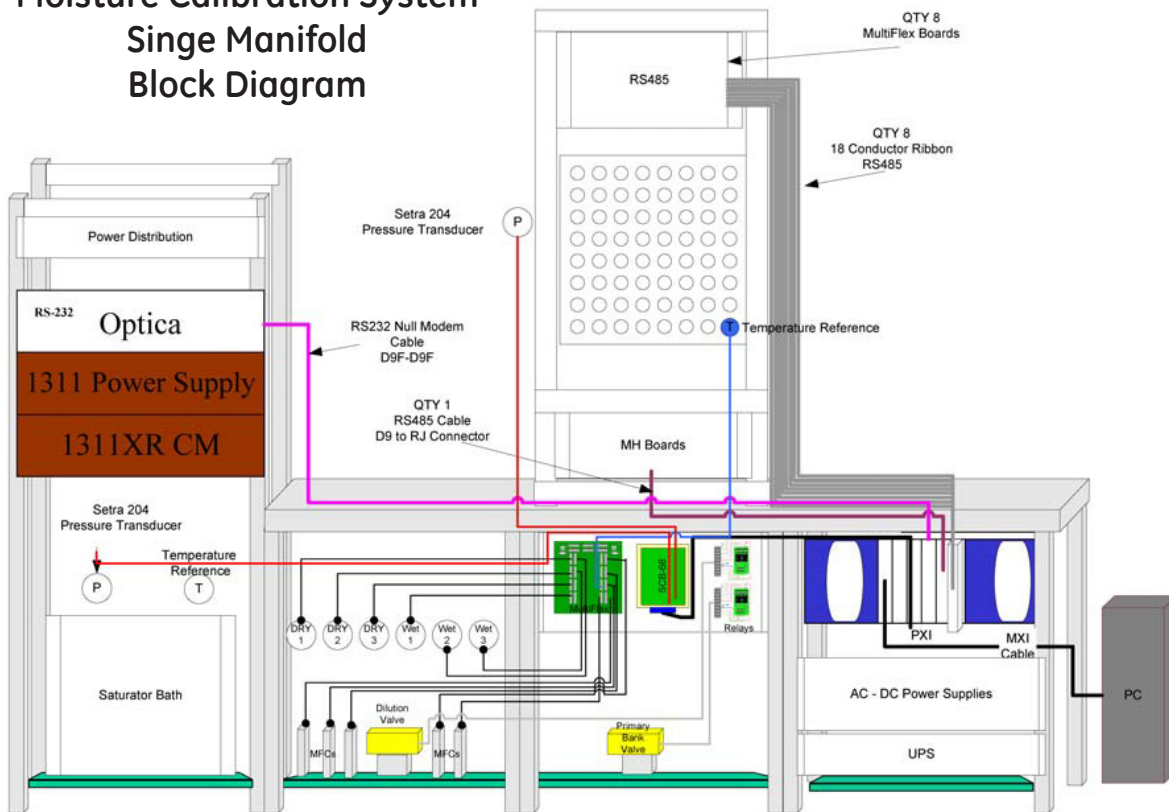

Calibration system located in a temperature and relative humidity controlled environment

Data Acquisition, Storage and Reduction

Data acquisition, storage and reduction is accomplished by collecting electronic impedance data for individual moisture sensors through the use of a direct reading of digital moisture probes, such as MISP or VeriDri types and by direct reading of analog moisture probes by means of master circuit measurement electronics module with an available channel for each slot in the calibration tank. The electronics of this module consists of analog signal processing and analog to digital conversion.

Impedance data for each sensor is accessed by a dedicated reference hygrometer channel for each probe on a continuous basis. Providing an individual analog measurement for each probe is a significant improvement over the heritage system that had limited analog measurement circuits and required a complex multiplexing system to measure all the various probes in the calibration bank. The net benefit to the system is faster measurement processing and reduced overall calibration cycle time.

The analog signal processing segment contains a unique self-calibration routine which is used to assure that any drift in the analog section of the system does not enter into the probe calibration data. To accomplish self-calibration, the analog electronics are commanded by the computer to read several high accuracy impedance standards. This data is fed back to the computer for testing against standard data. If the test data is within a predetermined maximum error band, it is accepted by the computer, which then generates a calibration curve. The calibration curve is automatically applied to the actual probe impedance data. After the analog data is collected and the calibration curve applied, it is converted to digital information by the A-D converter.

At completion of the calibration run, the digitized impedance data is moved to a long-term storage file. The data for at least the recent two calibration data sets is stored in this file. Inventory and probe suitability data is stored simultaneously.

The two data sets are used to calculate the actual drift over the last calibration time periods (minimum two month interval) and projected over the next six month period. The criteria for drift is that the calculated normalized drift rate must be less than $\pm 2^{\circ}\text{C}$ dew/frost point over a six month period.

In addition, the calibration data is archived to enable customers to access data about their sensors from an enterprise server. The historical data for a given sensor can be accessed and used to determine the long-term drift characteristics for a particular application.

Older hygrometer systems dating back into the 1960's are based on analog electronics. Many of these platforms are still in operation and moisture recalibration services are still offered on the aluminum oxide moisture probes for these units. Those hygrometers using linear analog circuitry, a curve is fitted to the data points using the following exponential equation:

$$Z^{-1} = Ae^{bT} + C$$

where

Z is the sensor impedance

T is the dew point temperature

A, b, and C are constants determined from the fit

Offset, span and electronic calibration factors are calculated for the best curve fit and a datasheet for the instrument of interest is generated by the calibration computer.



CALIBRATION DATA SHEET

GE

Probe Serial Number: 391402-PR
Last Calibration Date: 01-April-2008
Probe Part Number: M2LR

ND Number	Dew Point (Deg C)	MH Reading	Dew Point (Deg F)
0	-110	0.2286	-166
1	-100	0.2357	-148
2	-90	0.2430	-130
3	-80	0.2505	-112
4	-70	0.2585	-94
5	-60	0.2692	-76
6	-50	0.2821	-58
7	-40	0.2964	-40
8	-30	0.3194	-22
9	-20	0.3649	-4
10	-10	0.4442	14
11	0	0.5692	32
12	10	0.7787	50
13	20	1.068	68

Typical Calibration Data Sheet for a microprocessor-based hygrometer. For analog probes such as the common "M-Series" moisture probe, the moisture probe is calibrated and shipped with a calibration data sheet. The customer enters the 14-point calibration data into their hygrometer.

All current systems utilize microprocessor-based electronics. For these microprocessor based hygrometers, the Z^{-1} (sensor admittance) reading versus the dew/frost point is tabulated and a data sheet with all the necessary information for such instruments is generated.

A local pc-based computer is used to control the calibration system and to collect the calibration data. A National Instruments LabView interfaces with the controllers, to view and print sensor data, and to collect system diagnostics. The system is duplicated at GE facilities in Boston, MA; Shannon, Ireland; Abu Dhabi, UAE; Tokyo, Japan; and Changzhou, China.

While this paper is based on the primary calibration systems designed at GE's site in Billerica, MA using NIST traceable calibration reference standards, systems located in other geographic locations are traceable to the applicable ruling metrology authority. For example, GE's facility in Shannon, Ireland has their moisture calibration system use standards that are calibrated traceable to the National Physics Laboratory (NPL) in the UK.

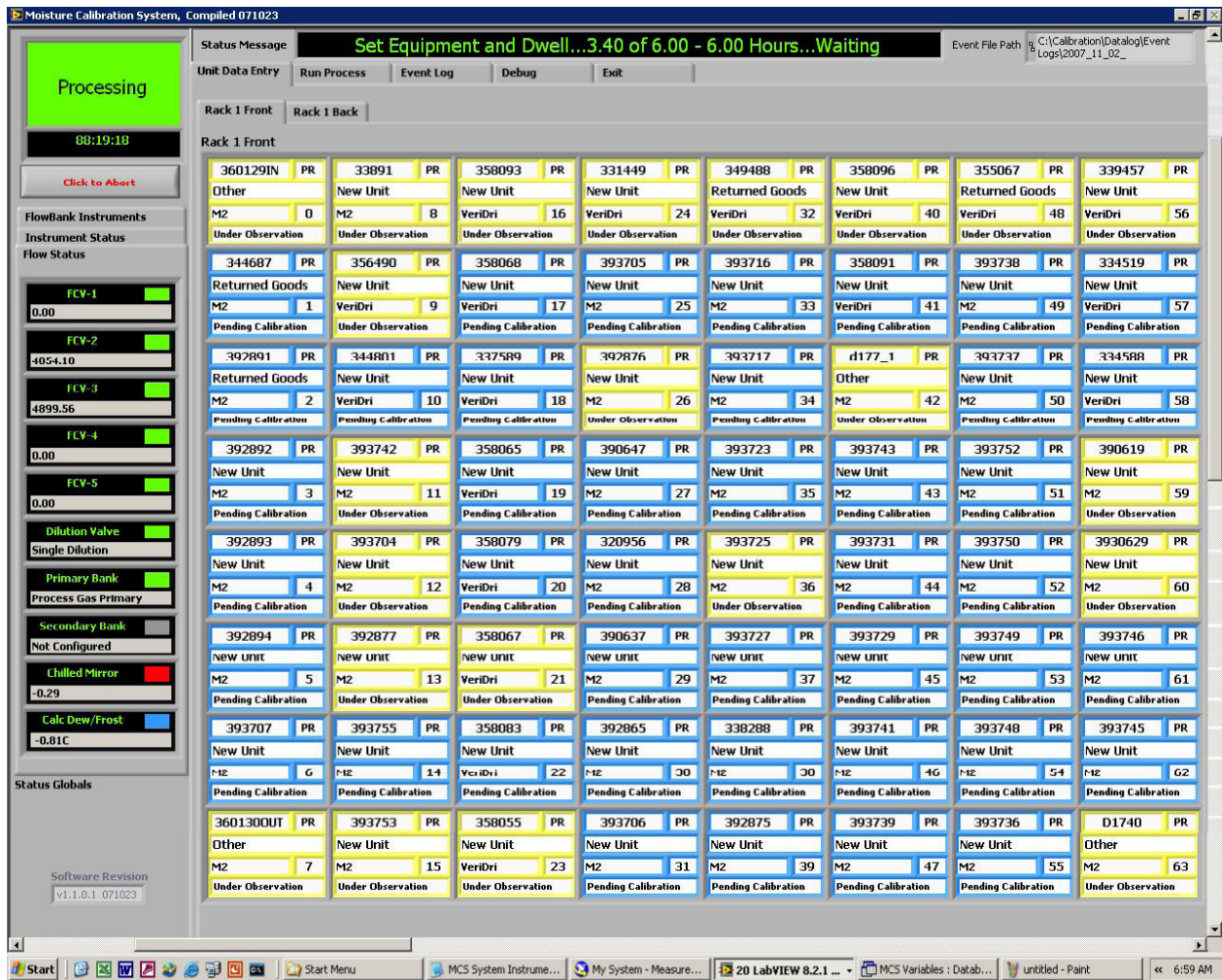

Calibration System LabView Interface offering intuitive graphical control and monitoring of the calibration run

Replication of this design, data collection, and system control globally makes it possible for the data and system verification diagnostics to be stored on redundant servers in a global database.

Conclusion

The GE primary calibration system is capable of calibrating up to 384 aluminum oxide moisture sensor probes per calibration run. Each run requires seven days for completion, including a three and one-half day dry down period.

The probes are normally calibrated at 10 dew/frost points over the range from -80°C to $+10^{\circ}\text{C}$, with an accuracy of the generated gas/water vapor mixture of better than $\pm 0.4^{\circ}\text{C}$ (see Appendix).

Temperature, pressure and flow measurement devices used in this system are all traceable to the National Institute of Standards and Technology. Thus, this calibration system meets the stated requirement, to calibrate aluminum oxide moisture probes in quantity on a production line basis, while maintaining rigorous quality control and quality assurance criteria.



Overall Aluminum Oxide Moisture Probe Calibration System View

Appendix

The error analysis of moisture generator system is divided into an analysis of gas saturation and an analysis of gas dilution.

Saturator Section - The vapor pressure of water generated by the saturator is given by the equation

$$P_{o_s} = K_w \times 6.112 \exp\left(\frac{17.502 t}{240.97 + t}\right)$$

$$K_w = 1.0007 + 3.46 \times 10^{-6} P_t$$

and the vapor pressure of water delivered to the calibration banks is given by the equation

$$P_s = P_{o_s} \times \left(\frac{P_T}{P_{o_T}}\right)$$

where

P_s = Vapor pressure of water in calibration chamber

P_{o_s} = Vapor pressure of water generated in saturator at temperature

P_T = Total pressure in calibration chamber

P_{o_T} = Total pressure in saturator

K_w = Enhancement factor

t = Temperature within the saturator

The absolute accuracy of the saturator, based on the accuracy of NIST traceable thermometer (+/- 0.10°C) and pressure gauge (+/- 0.05 psi), is +/- 0.7% in P_s , or +/- 0.11°C in dew point.

Dilution Section - The error in the dilution section varies somewhat for different dew points, due to the different flow rates and number of flowmeters employed. The vapor pressure of water generated by dilution, P_w , is given by

$$P_w = P_s \left(\frac{F_{w1}}{F_{w1} + F_{D1}}\right) \times \left(\frac{F_{w2}}{F_{w2} + F_{D2}}\right)$$

where

P_s = Vapor pressure output by the saturator

F_{w1} = Wet gas flow for first dilution (FCV-1, FCV-2)

F_{D1} = Dry gas flow for first dilution (FCV-3)

F_{w2} = Moist gas flow for second dilution (FCV-4)

F_{D2} = Dry gas flow for second dilution (FCV-5)

A complete expression for the error in the above equation can be calculated⁽¹⁾. It is given by

$$\frac{\Delta P_w}{P_w} = \left[\left(\frac{\Delta P_s}{P_s} \right)^2 + \left(\frac{F_{D1}}{F_{D1} + F_{w1}} \right)^2 \left[\left(\frac{\Delta F_{w1}}{F_{w1}} \right)^2 + \left(\frac{\Delta F_{D1}}{F_{D1}} \right)^2 \right] + \left(\frac{F_{D2}}{F_{D2} + F_{w2}} \right)^2 \left[\left(\frac{\Delta F_{w2}}{F_{w2}} \right)^2 + \left(\frac{\Delta F_{D2}}{F_{D2}} \right)^2 \right] \right]^{1/2}$$

The error in P_s , +/- 0.7%, has been derived. The flowmeter accuracy, specified by an independent calibration in service, is +/- 2% of flow or +/- 0.5% full-scale flow, whichever is larger. The application of second equation referenced to the data in Flowrates & Accuracies for Generation of Dew/Frost Point Temperatures table yields errors for each dew point.

The errors in water vapor pressure vary from +/- 0.7% at the highest dew point up to +/- 6.8% at the lowest dew point. These errors, converted to a dew point scale, are listed in Flowrates & Accuracies for Generation of Dew/Frost Point Temperatures table. The dew point errors vary from +/- 0.1°C to +/- 0.40°C.

The systematic error in dew point due to moisture in the dry gas may be neglected at all dew points wetter than -80°C. For the -80°C point the error is less than +0.4°C in dew point. This is based on a maximum -85°C dew point at 90 psig in the dry gas supply line.

Acknowledgments

The author would like to acknowledge several persons for their contributions to developing the calibration system described herein. A partial list of those people include James Figucia for LabView interface work; Gene Berkowitz, Joe Ferro and Tony Kowal for engineering efforts on GE hygrometers and probes; Dave Spielman for manufacturing engineering efforts to design, build and test the calibration system; Steve Rehn for quality and calibration system expertise; and Sean Donahue for quality leadership efforts.

REFERENCES

1. Dietrich. C.F., "Uncertainty, calibration, and Probability", John Wiley, New York, 1973, p. 269.
2. Scelzo, Michael; Pierce, Ralph. "A High Precision Saturation Dilution System for Water Vapor in a Carrier Gas". Proceedings of the 1985 International Symposium on Moisture & Humidity. Instrument Society of America, Research Triangle Park, NC. 1985. ISBN 0-87664-865-0.



*Trademarks of General Electric Company.

©2016 General Electric Company. All rights reserved.

03/2016