



—  
your partner  
in sensor  
technology.



# User Manual EE680

**Air Velocity and Temperature  
Sensor for Laminar Flow**



# Content

<b>1</b>	<b>General Information</b>	<b>3</b>
1.1	Explanation of Warning Notices and Symbols	3
1.2	Safety Instructions	4
1.2.1.	General Safety Instructions	4
1.2.2.	Intended Use	4
1.2.3.	Mounting, Start-up and Operation	4
<b>2</b>	<b>Scope of Supply</b>	<b>5</b>
<b>3</b>	<b>Product Description</b>	<b>6</b>
3.1	General	6
3.2	Dimensions	6
3.3	Electrical Connection	8
3.4	Hardware Selection between Analogue Output and RS485 Interface with Modbus RTU	8
<b>4</b>	<b>Probe Mounting</b>	<b>9</b>
<b>5</b>	<b>Setup and Configuration</b>	<b>11</b>
5.1	PCS10 Product Configuration Software	11
5.2	Digital Interface RS485 with Modbus RTU Protocol	12
5.3	Modbus Register Map	13
5.4	Device Status Indication	13
5.5	Modbus RTU Example	14
<b>6</b>	<b>Maintenance and Service</b>	<b>15</b>
6.1	Cleaning	15
6.2	Transportation	15
6.3	Optical Status Indication with LED Ring	16
6.4	Error Messages in PCS10	16
6.5	Error Indication on the Analogue Output (NAMUR)	17
6.6	Repairs	17
<b>7</b>	<b>vn/T Calibration and Adjustment</b>	<b>17</b>
7.1	Selection of Appropriate Adjustment Method	17
7.1.1.	General Information on 1-Point vn/T Adjustment	17
7.1.2.	General Information on 2-Point vn/T Adjustment	18
7.2	Adjustment with PCS10	18
7.3	Calibration and Adjustment at E+E Elektronik	18
<b>8</b>	<b>Accessories</b>	<b>18</b>
<b>9</b>	<b>Technical Data</b>	<b>19</b>
<b>10</b>	<b>Conformity</b>	<b>20</b>
10.1	Declarations of Conformity	20
10.2	Electromagnetic Compatibility	20
10.3	FCC Part 15 Compliance Statement	20
10.4	ICES-003 Compliance Statement	20
<b>11</b>	<b>Recycling of the Device</b>	<b>20</b>

# 1 General Information

This user manual is intended to ensure proper handling and optimal functioning of the device. The user manual shall be read before commissioning the equipment and it shall be provided to all staff involved in transport, installation, operation, maintenance and repair. E+E Elektronik Ges.m.b.H. accepts no liability for any warranty or liability claims arising from this publication or improper handling of the product(s) described.

All information, technical data and diagrams included in this document are based on the information available at the time of writing. The document may contain technical inaccuracies and typographical errors. The contents will be revised on a regular basis and changes will be implemented in subsequent versions. The product(s) described and the contents of this document may be changed or improved at any time without prior notice.

All rights are reserved by E+E Elektronik Ges.m.b.H. No part of this document may be reproduced, published or publicly displayed in any form or by any means, nor may its contents be modified, translated, adapted, sold or disclosed to a third party without prior written permission of E+E Elektronik Ges.m.b.H.

## PLEASE NOTE

Find this document and further product information on our website at [www.epluse.com/ee680](http://www.epluse.com/ee680).

## 1.1 Explanation of Warning Notices and Symbols

### Safety precautions

Precautionary statements warn of hazards in handling the device and provide information on their prevention. The safety instruction labeling is classified by hazard severity and is divided into the following groups:

### DANGER

**Danger** indicates hazards for persons. If the safety instruction marked in this way is not followed, the hazard will very likely result in severe injury or death.

### WARNING

**Warning** indicates hazards for persons. If the safety instruction marked in this way is not followed, there is a risk of injury or death.

### CAUTION

**Caution** indicates hazards for persons. If the safety instruction marked in this way is not followed, minor or moderate injuries may occur.

### NOTICE

**Notice** signals danger to objects or data. If the notice is not observed, damage to property or data may occur.

### Informative notes

Informative notes provide important information that is characterised by its relevance.

## INFO

The information symbol indicates tips on handling the device or provides additional information on it. The information is useful for reaching optimal performance of the device.

The title field can deviate from "INFO" depending on the context. For instance, it may also read "PLEASE NOTE".

## 1.2 Safety Instructions

### 1.2.1. General Safety Instructions

#### NOTICE

Improper handling of the device may result in its damage.

- The probe shall not be exposed to unnecessary mechanical stress.
- The sensing element is sensitive to electrostatic discharge (ESD), avoid touching the sensing element whenever possible, appropriate protective measures should be taken when touching it.
- Installation, electrical connection, maintenance and commissioning shall be performed by qualified personnel only.
- Use the EE680 only as intended and observe all technical specifications.
- Do not use EE680 in explosive atmosphere or for measurement of aggressive gases.
- Do not apply the nominal voltage to the RS485 data lines.
- This device is not appropriate for safety, emergency stop or other critical applications where device malfunction or failure could cause injury to human beings.

### 1.2.2. Intended Use

The EE680 is intended for monitoring laminar flows fulfilling highest requirements for use in GMP Grade A and B or ISO class 5 clean rooms and above. It measures the standardised air velocity ( $v_n$ ) and the temperature ( $T$ ) highly accurate. The EE680 is designed to be GMP-compliant and is therefore ideal for sectors such as microelectronics, the pharmaceutical industry and other life science sectors. The EE680 is not designed for outdoor applications. It is suitable for use in clean gases (air) free from oils, residue-forming substances or abrasive particles.

#### WARNING

Non-compliance with the product documentation may cause safety risk for people and the entire measurement installation.

The manufacturer is not liable for any damage caused by improper handling, installation and maintenance of the device.

The use of the EE680 in any other way than described in this manual bears a safety risk for people and the entire measurement installation and is therefore not allowed.

In order to avoid damage to the instrument or health hazards, the measuring equipment must never be manipulated with tools that are not specifically described in this manual.

The sensor may only be utilised in accordance with the conditions defined in the technical data. Otherwise, measurement inaccuracies will occur and equipment failures cannot be ruled out.

The steps recommended by the manufacturer for installation, inspections and maintenance work must be observed and carried out for the safety of the user and for the functionality of the equipment.

#### NOTICE

Failure to follow the instructions in this user manual may lead to measurement inaccuracy and device failures.

- The EE680 may only be operated under the conditions described in this user manual and within the specification included in chapter 9 Technical Data.
- Any unauthorised product modifications will invalidate all warranty claims. Modifications may only be carried out with the express authorisation of E+E Elektronik Ges.m.b.H.!

### 1.2.3. Mounting, Start-up and Operation

The EE680 air velocity and temperature sensor for laminar flow has been produced under state of the art manufacturing conditions, has been thoroughly tested and has left the factory after fulfilling all safety criteria. The manufacturer has taken all precautions to ensure safe operation of the device. The device shall be set up and installed in a way that does not impair its safe use. All applicable local and international safety guidelines for safe installation and operation of the device have to be observed. This user manual contains information and warnings that must be observed in order to ensure safe operation.

**i PLEASE NOTE**

The manufacturer or his authorised agent can only be held liable in case of willful or gross negligence. In any case, the scope of liability is limited to the corresponding amount of the order issued to the manufacturer. The manufacturer assumes no liability for damage caused by non-compliance with the applicable regulations, operating instructions or the specified operating conditions. Any consequential damage is excluded from liability.

---

**⚠ WARNING**

Non-compliance with the product documentation may result in accidents, personal injury or property damage.

- Mounting, installation, commissioning, start-up, operation and maintenance of the device may only be carried out by qualified staff. Such staff must be authorised by the operator of the facility to carry out the mentioned activities.
  - The qualified staff must have read and understood this user manual and must follow the instructions contained within. The manufacturer accepts no responsibility for non-compliance with instructions, recommendations and warnings.
  - All process and electrical connections must be thoroughly checked by authorised staff before commissioning the device.
  - Do not install or start-up a device suspected to be faulty. Mark it clearly as faulty and remove it from the process.
  - Service operations other than described in this user manual may only be performed by the manufacturer. A faulty device may only be investigated and possibly repaired by qualified, trained and authorised staff. If the fault cannot be fixed, the device shall be removed from the process.
- 

## 2 Scope of Supply

- EE680 – Air Velocity and Temperature Sensor for Laminar Flow (with protection cap)
- EE680 stainless steel mounting flange
- Inspection certificate according to DIN EN 10204-3.1
- Quick guide

# 3 Product Description

## 3.1 General

The EE680 probe is optimised for highly accurate and reliable standardised air velocity ( $v_n$ ) and temperature (T) measurement in GMP Grade A and B or ISO class 5 clean rooms and above. Its GMP-compliant design makes it the ideal probe for laminar flow monitoring in clean rooms with the highest requirements. The probe reliably measures air velocity down to 0.1 m/s (20 ft/min).

The EE680 is available in straight and angled versions, with various lengths. All variants provide an optical status indication - see chapter 6.3.

The probe employs an E+E thin-film sensing element with excellent accuracy, long-term stability and low angular dependency. The E+E proprietary coating protects the sensing element against  $H_2O_2$  sterilisation processes and corrosive cleaning agents.

The  $v_n$  and T measured data is available as analogue current or voltage output or on the RS485 interface with Modbus RTU protocol. The analogue output and other settings can be configured using the PCS10 Product Configuration Software.

## 3.2 Dimensions

Values in mm / inch

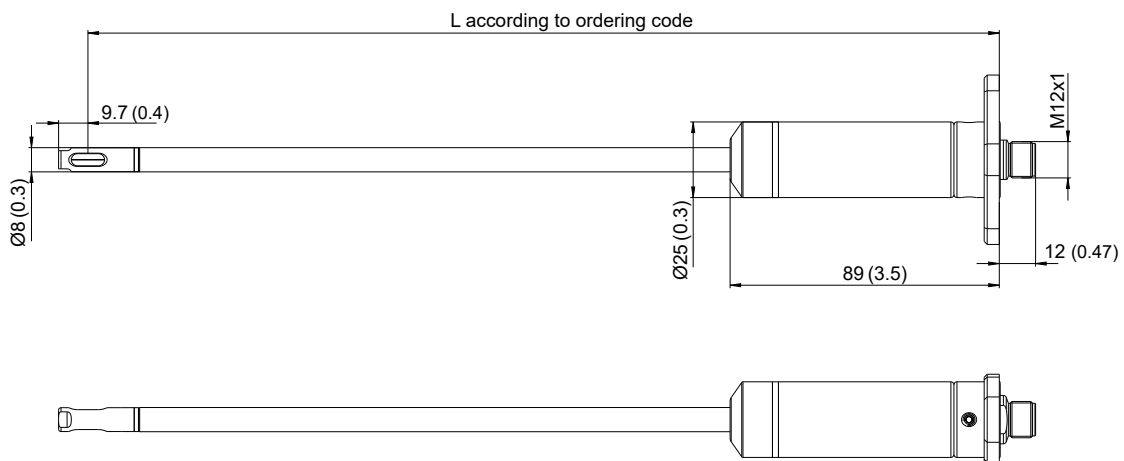

Fig. 1 EE680 straight probe

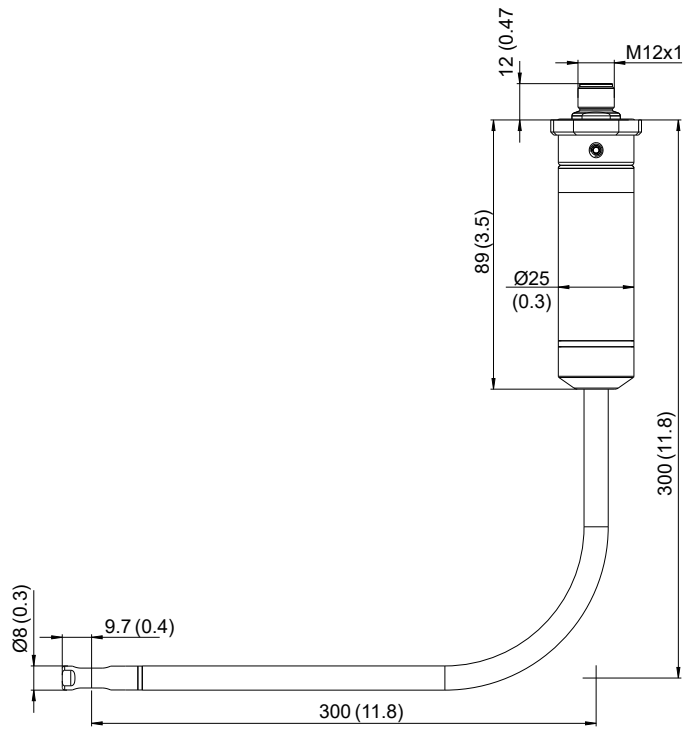

Fig. 2 EE680 angled probe

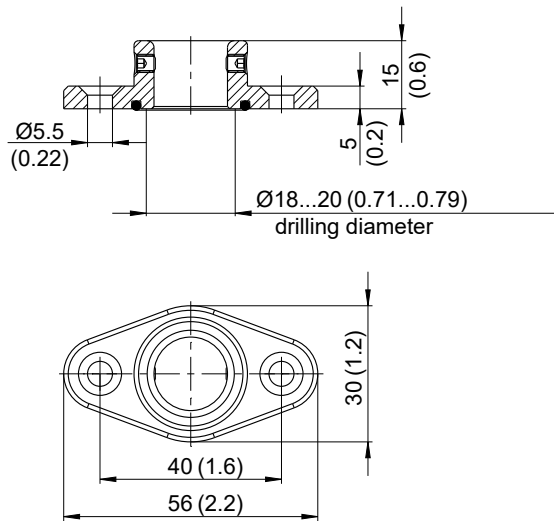

Fig. 3 Mounting flange for EE680

### 3.3 Electrical Connection

#### **⚠ WARNING**

Incorrect installation, wiring or power supply may cause overheating and result in personal injury or property damage.

Cables must not be under voltage during electrical installation and connection or disconnection, especially at terminal connections on circuit boards. For correct cabling, always observe the presented wiring diagram for the product version used.

The manufacturer cannot be held responsible for personal injury or damage to property caused by incorrect handling, installation, wiring, power supply or maintenance of the device.

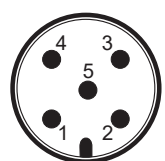

M12 device plug  
front view

Pin	Assignment	Wire colors for accessories: - Flange coupling HA010705 - Sensor connection cable HA010819/820/821
1	Supply voltage 24 V DC $\pm 20\%$ (Class III)	brown
2	Analogue out 2 or RS485 (D-), Data	white
3	GND	blue
4	Analogue out 1 or RS485 (D+), Clock	black
5	Configuration pin	grey

Tab. 1 EE680 pin assignment

#### **i PLEASE NOTE**

In order to comply with the EMC Directive 2004/108/EC, a shielded connection cable must be used.

### 3.4 Hardware Selection between Analogue Output and RS485 Interface with Modbus RTU

	Default: analogue	Default: Modbus RTU
Pin 5 open (=HIGH)	10 s timeout <sup>1)</sup> , then analogue output	Modbus RTU
Pin 5 GND (=LOW)	Analogue	Analogue

1) For configuration purposes, during the first 10 seconds after power on, the EE680 awaits connection with the PCS10 Product Configuration Software.

Tab. 2 Function of the configuration pin (pin 5 of M12 connector)

The “default output” of the EE680 can be analogue or Modbus RTU. The “default output” of a new EE680 corresponds to the specified order code, refer to the EE680 datasheet. In case of a customer specific setting, the “default output” is the latest setting uploaded to the EE680 by means of the PCS10 Product Configuration Software (please refer to the tutorial function of PCS10).

## 4 Probe Mounting

The EE680 can be mounted on walls, ceilings or inside safety workbenches. Fig. 4 and Fig. 5 show the principal probe mounting alternatives, depending on the probe type.

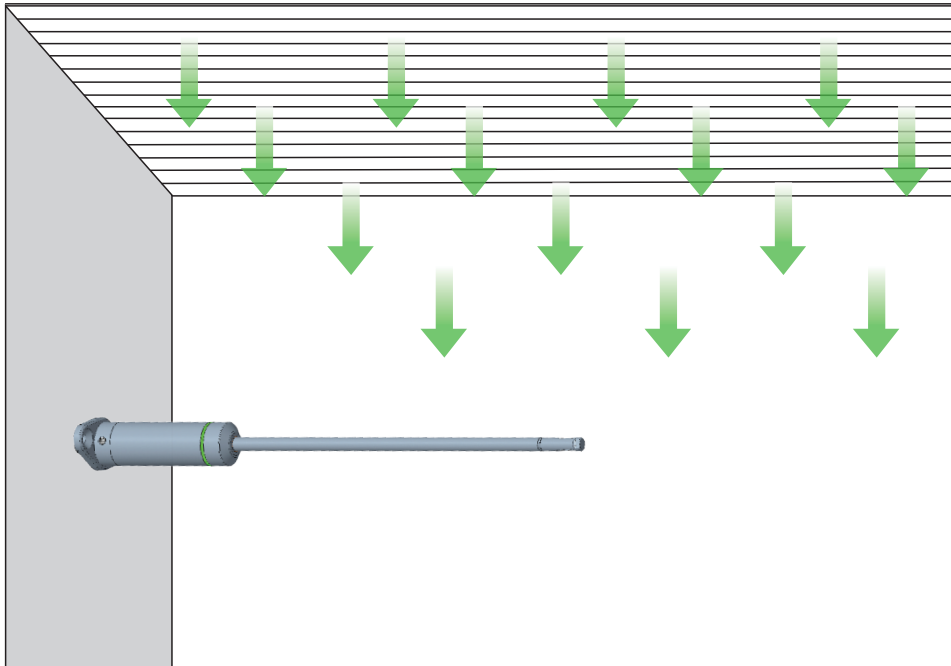

Fig. 4 EE680 mounting on a wall

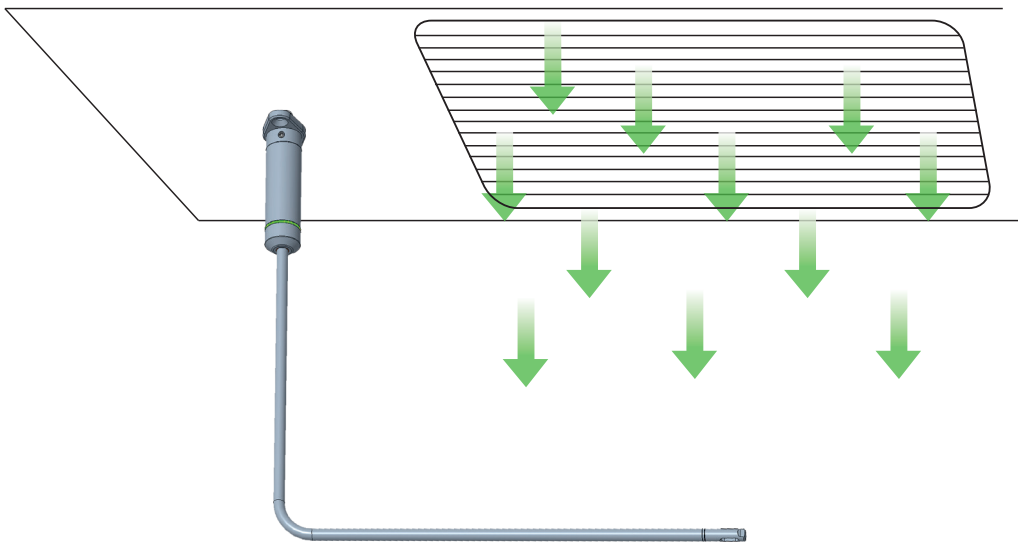

Fig. 5 EE680 mounting on a ceiling

The stainless steel mounting flange allows for the probe to be mounted on a wall or inside a safety workbench.

After fastening the flange, feed the connection cable through the flange to connect it with the sensor. For convenient handling, the cable should extend 5 cm (2") from the flange, leaving enough space behind the flange. Connect the probe to the M12 connector. Insert the sensor into the flange and adjust the sensor position so that the sensing element and the air flow are parallel. Finally, secure the sensor in the flange with the Allen screw.

For facilitating sheet metal wall mounting, use the mounting set available as accessory (HA011601) consisting of counter plate, sealing and screws. Please refer to Fig. 8.

Remove the sensor protection cap before commissioning.

The EE680 sensing head is asymmetric and has a 2D barcode printed on top.

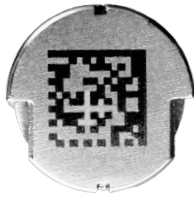

Fig. 6 Asymmetric EE680 sensor head

**i PLEASE NOTE**

For best measuring accuracy, the sensing element of the EE680 must be aligned exactly in the direction of the laminar flow in which factory adjustment took place.

The angular deviation must be kept to a minimum.

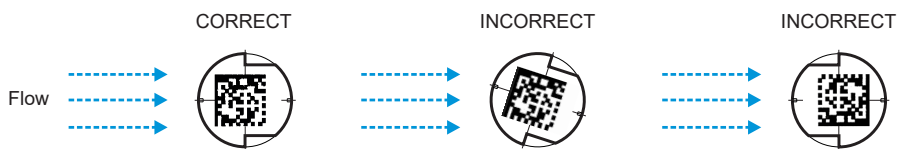

Fig. 7 Correct laminar flow alignment



Fig. 8 EE680 mounting flange and mounting set (HA011601)

When cleaning the site, remove the sensor and protect the electrical connection with the help of the sealing plug which is available as accessory (HA011602). Please refer to Fig. 9.



Fig. 9 EE680 mounting flange and sealing plug (HA011602)

# 5 Setup and Configuration

The EE680 is ready to use and does not require any configuration by the user. The EE680 factory setup corresponds to the specified order code. Please refer to the data sheet at [www.epluse.com/ee680](http://www.epluse.com/ee680). If needed, the factory setup can be changed. This chapter describes the configuration possibilities with the PCS10 Product Configuration Software and the Modbus configuration adapter (order code HA011018) and via the digital RS485 interface with Modbus RTU.

Besides the measurand selection at the analogue and digital outputs and their scaling, the digital interface settings may be changed. The  $v_n$  and T measurements are offset and 2-point adjustable. It is possible to enable or disable the optical status indication (factory setting: enabled), the NAMUR error indication (factory setting: disabled) and the low flow suppression (factory setting: disabled). The response time and temperature and barometric pressure reference values for standardised air velocity calculation can be set.

## NOTICE

The EE680 may not be connected to any additional power supply when using the Modbus configuration adapter HA011018.

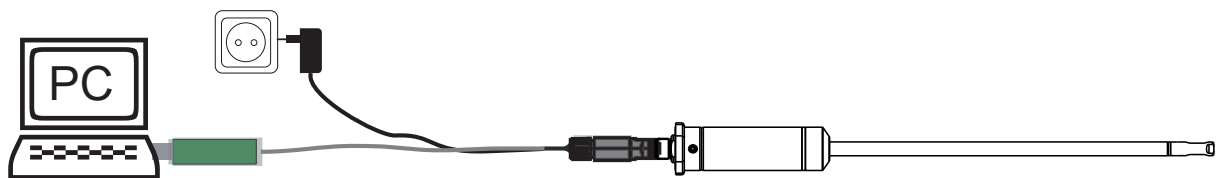

Fig. 10 EE680 configuration and adjustment

## 5.1 PCS10 Product Configuration Software

The PCS10 provides a convenient graphical user interface to the EE680 for changing the factory setup via PCS10 and Modbus configuration adapter. The EE680 is powered via the adapter then, no additional power supply shall be applied.

## NOTICE

Data integrity might not be provided during firmware download.

Ensure that the device is only powered by the USB interface during firmware update, otherwise the update may fail.

To use the software to change the settings, please proceed as follows:

1. Download the PCS10 Product Configuration Software from [www.epluse.com/pcs10](http://www.epluse.com/pcs10) and install it on the PC.
2. Connect the EE680 to the PC using the Modbus configuration adapter.
3. Start the PCS10 software.
4. Follow the instructions on the PCS10 opening page to scan the ports and to identify the connected device.
5. Click on the desired setup or adjustment mode from the main PCS10 menu on the left. Follow the PCS10 online instructions that are displayed when clicking on the "Tutorial" button.
6. Upload changes to the probe by pressing the "Sync" button.

## 5.2 Digital Interface RS485 with Modbus RTU Protocol

	Factory settings	Selectable values (via PCS10)
Baud rate	9 600	9 600, 19 200, 38 400, 57 600, 76 800, 115 200
Data bits	8	8
Parity	Even	None, odd, even
Stop bits	1	1, 2
Modbus address	68	1...247

Tab. 3 Digital interface default settings

### **i** PLEASE NOTE

- The recommended settings for multiple devices in a Modbus RTU network are 9600, 8, even, 1.
- The EE680 represents 1/10 unit load on an RS485 network.

Device address, baud rate, parity and stop bits can be set via:

- PCS10 Product Configuration Software and the USB configuration adapter HA011018. The PCS10 can be downloaded free of charge from [www.epluse.com/pcs10](http://www.epluse.com/pcs10).
- Modbus protocol in the register 1 (0x00) and 2 (0x01). See Application Note Modbus AN0103 (available at [www.epluse.com/ee680](http://www.epluse.com/ee680)).

The serial number as ASCII-code is located in read-only registers 1 - 8 (0x00 - 0x07).

The firmware version is located in read-only register 9 (0x08) (bit 15...8 = major release; bit 7...0 = minor release).

The sensor name as ASCII-code is located in read-only registers 10 - 17 (0x09 - 0x10).

### NOTICE

When reading information that spans multiple registers, it is always necessary to read all registers, even if the desired information requires less.

### NOTICE

To obtain the correct floating point values, both registers have to be read within the same read cycle. The measured value may change between two Modbus requests. This can cause inconsistencies in the exponent and mantissa.

#### Communication settings (INT16)

Parameter	Register number <sup>1)</sup> [Dec]	Register address <sup>2)</sup> [Hex]	Size <sup>3)</sup>
Write register: function code 0x06			
Modbus address <sup>4)</sup>	1	00	1
Modbus protocol settings <sup>4)</sup>	2	01	1

#### Device information (INT16)

Parameter	Register number <sup>1)</sup> [Dec]	Register address <sup>2)</sup> [Hex]	Size <sup>3)</sup>
Read register: function code 0x03 / 0x04			
Serial number (as ASCII)	1	00	8
Firmware version	9	08	1
Sensor name (as ASCII)	10	09	8
Device status	602	259	1

1) Register number starts from 1.

2) Protocol address starts from 0.

3) Number of registers

4) For Modbus address and protocol settings see Application Note Modbus AN0103 (available at [www.epluse.com/ee680](http://www.epluse.com/ee680)).

Tab. 4 EE680 registers for device setup

## 5.3 Modbus Register Map

The measurement data is saved as 32 bit floating point values (data type FLOAT32) and as 16 bit signed integer values (data type INT16).

### FLOAT32

Parameter	Unit <sup>1)</sup>	Register number <sup>2)</sup> [DEC]	Register address <sup>3)</sup> [HEX]
Read register: function code 0x03 / 0x04			
Standardised air velocity $v_n$ <sup>3)</sup>	m/s	1045	414
	ft/min	1047	416
Temperature T	°C	1003	3EA
	F	1005	3EC

### INT16

Parameter	Unit <sup>1)</sup>	Scale <sup>4)</sup>	Register number <sup>2)</sup> [DEC]	Register address <sup>3)</sup> [HEX]
Read register: function code 0x03 / 0x04				
Standardised air velocity $v_n$ <sup>3)</sup>	m/s	100	4023	FB6
	ft/min	0.1	4024	FB7
Temperature T	°C	100	4002	FA1
	F	50	4003	FA2

1) Register number starts from 1

2) Register address starts from 0

3) Standardised air velocity  $v_n$  at standard conditions (factory setup):  $T_n = 23\text{ °C}$  (73 °F),  $p_n = 1\,013.25\text{ hPa}$  (14.7 psi), configurable via PCS10

4) Examples: For scale 100, the reading of 2550 means a value of 25.5. For scale 50, the reading of 2550 means a value of 51.

Tab. 5 EE680 FLOAT32 and INT16 measured data registers

## 5.4 Device Status Indication

The EE680 features a status register that contains all status and error information. The status information can be read from Modbus register 602 (0x259). Errors are displayed in bit-coded form. If an event is present, the corresponding bit is set to 1.

If a critical error occurs, all Modbus values are set to NaN (according to IEEE754 for data type FLOAT32) or to 0x8000 (INT16).

Measured values out of range are limited by the corresponding limit value.

Error Bits	Description	Recommended action
Bit 0	Sensor not adjusted	Return the unit to the E+E Customer Service.
Bit 1	Resistive measurement faulty	Clean sensing head acc. to cleaning instructions. If unit faulty, return it to E+E for service.
Bit 2	Temperature below T working range	Return the unit to the E+E Customer Service.
Bit 3	Temperature above T working range	Observe the upper working range limit.
Bit 4	T sensing element broken	Return the unit to the E+E Customer Service.
Bit 5	Air velocity below v working range	Observe the lower working range limit.
Bit 6	Air velocity above v working range	Observe the upper working range limit.
Bit 7	v sensing element broken	Return the unit to the E+E Customer Service.
Bit 8	-	-
Bit 9	-	-
Bit 10	-	-
Bit 11	-	-
Bit 12	-	-
Bit 13	-	-
Bit 14	-	-
Bit 15	-	-

Tab. 6 Device status indication

## 5.5 Modbus RTU Example

The EE680 Modbus address is 68 [0x44].

Please refer to

- MODBUS APPLICATION PROTOCOL SPECIFICATION V1.1b3, chapter 6:  
[www.modbus.org/docs/Modbus\\_Application\\_Protocol\\_V1\\_1b3.pdf](http://www.modbus.org/docs/Modbus_Application_Protocol_V1_1b3.pdf)
- E+E Application Note Modbus AN0103 (available at [www.epluse.com/ee680](http://www.epluse.com/ee680))

Read the standardised air velocity (FLOAT32)  $v_n = 0.4581840038299560546875$  m/s from register address 1045 (0x414) with function code 0x03:

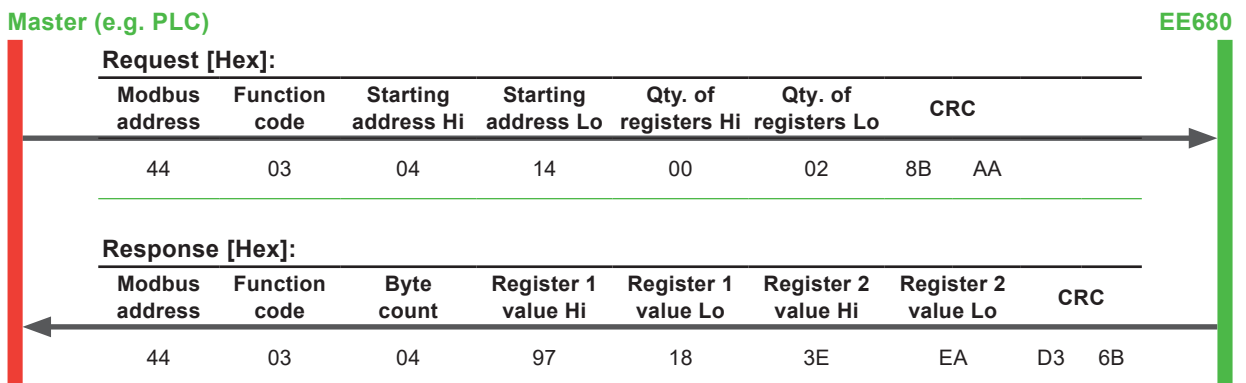

Tab. 7 Example air velocity query

### Decoding of floating point values:

Floating point values are stored according to IEEE754. The byte pairs 1, 2 and 3, 4 are transformed as follows (numbers taken from  $v_n$  reading Modbus request/response example above):

**Modbus response [Hex]**

Byte 3	Byte 4	Byte 1	Byte 2
97	18	3E	EA
MMMMMMMM	MMMMMMMM	SEEEEEEE	EMMMMMMM

Tab. 8 Modbus response

**IEEE754**

Byte 1	Byte 2	Byte 3	Byte 4
3E	EA	97	18
0100 0001	1100 1000	1011 0011	0111 1110
SEEE EEEE	EMMM MMMM	MMMM MMMM	MMMM MMMM
Decimal value [m/s]: 0.4581840038299560546875			

Tab. 9 Data representation according to IEEE754

# 6 Maintenance and Service

EE680 does not require any special maintenance. Nevertheless, calibrate the probe every 6 - 12 months for highly accurate measurements. Contamination of the sensor element and the sensor head may lead to false measurement values. Therefore, check the sensor head regularly for contamination. If necessary, clean the enclosure and the sensor head as described below and the device may be re-adjusted as described in chapter 7.

## 6.1 Cleaning

The EE680's materials (probe and sensor head made of stainless steel 1.4404) has been optimised to provide the best possible resistance to H<sub>2</sub>O<sub>2</sub> sterilisation processes and corrosive cleaning agents.

Approved cleaning methods are:

- H<sub>2</sub>O<sub>2</sub> sterilisation with 6 % concentrated H<sub>2</sub>O<sub>2</sub> surface cleaning agents
- Isopropyl alcohol
- Water

### PLEASE NOTE

Inappropriate cleaning agents may deposit on the sensing element, resulting in incorrect measured values or permanent damage to the sensing element.

For any other than the approved methods, the protection cap included must be mounted prior to cleaning.

### Cleaning of the sensing head/probe body

If the sensing head or especially the sensing element is dusty or dirty, it may be carefully cleaned with oil-free compressed air.

### NOTICE

Do not apply any hard pressure shocks on the sensing element.

If cleaning with compressed air is not successful, the sensing head can be carefully cleaned using water, isopropyl alcohol or H<sub>2</sub>O<sub>2</sub> sterilisation (6 % concentration) by repeated immersion and drying.

Cleaning with water:

1. Remove the power supply from the device
2. Flush with the selected detergent
3. Dry in the air
4. Reapply power to the device

### NOTICE

- Do not touch the sensing element with your fingers at any time!
- Do not shake, knock or tap the wet sensor head!
- Any mechanical contact with the sensing element incorporated in the sensing head will cause irreversible damage to the sensor and needs to be avoided at any time!
- Do not use any cleaning objects (e.g. brushes) to clean the sensor head!

## 6.2 Transportation

Whenever EE680 is needed to be returned for calibration, adjustment or repairs to E+E Elektronik GmbH, contamination and any mechanical stresses during transport have to be avoided by appropriate packaging measures. Please use the protection cap included in the scope of the supply (see chapter 2 Scope of Supply).

### CAUTION

Returned sensors must not be harmful to the health of our employees at any time.

If the product was in contact with contaminating (poisonous, hazardous, explosive, ...) substances, decontamination of the sensor must be ensured before returning.

## 6.3 Optical Status Indication with LED Ring

The status of the laminar flow and of the probe is indicated by the LED ring embedded in the probe body. The optical status indication behaviour can be adjusted. Choose from the following options:

- Enable / disable optical status indication (factory setting: enabled)

If enabled, two status indication modes are selectable:

- Error indication: shows the probe status.
- Laminar flow state: additionally indicates whether the measured flow is within or beyond the predefined, user configurable range

The table below summarises the meaning of LED indication:

Colour	Flow status	Probe status
None	Faulty power supply or optical status indication disabled.	
Green	Measured value within range	Normal, failure-free operation
Yellow flashing	Measured value out of range	
Red flashing	Failure, return sensor to E+E for investigation	

Tab. 10 Meaning of LED ring indication

On delivery, the EE680 monitors the flow using the factory preset values according to Tab. 11.

	Low threshold	High threshold
Standardised air velocity $v_n$	0 m/s (0 ft/min)	2 m/s (394 ft/min)
Red flashing	0 °C (32 °F)	50 °C (122 °F)

Tab. 11 Factory default values for laminar flow monitoring

## 6.4 Error Messages in PCS10

The PCS10 information section includes error messages from EE680, if errors occur. The following table shows the error codes and their meaning. Please note that this table directly corresponds to Tab. 6 in chapter 5.4 Device Status Indication.

Error code	Description	Recommended action
7.x	Temperature measurement incorrect	1. Check the actual temperature and the T output scaling of the ordered sensor, check the wiring 2. Service recommended, check the repair possibilities with the E+E service
12.x	Temperature sensing element faulty	Service recommended, check the repair possibilities with the E+E service
13.x	Sensor not adjusted	1. check the repair possibilities with the E+E service
17.x	Air velocity measurement incorrect	1. Check the actual air velocity and the $v_n$ output scaling of the ordered sensor, check the wiring 2. Service recommended, check the repair possibilities with the E+E service

Tab. 12 PCS10 error messages for EE680

## 6.5 Error Indication on the Analogue Output (NAMUR)

The EE680 features an error indication on its analogue outputs according to the NAMUR NE 043 recommendations (Standardisation of the Signal Level for the Failure Information of Digital Transmitters, Edition 2003-02-03, see [www.namur.net/en/recommendations-and-worksheets/current-nena.html](http://www.namur.net/en/recommendations-and-worksheets/current-nena.html)).

The feature is disabled by factory default and can be enabled with the PCS10 Product Configuration Software.

Output signal	NAMUR signal level
0 - 5 V	5.5 V
0 - 10 V	11 V
0 - 20 mA	21 mA
4 - 20 mA	21 mA

Tab. 13 NAMUR error indication

## 6.6 Repairs

### **i** PLEASE NOTE

Repairs may only be carried out by the manufacturer. The attempt of unauthorised repair excludes any warranty claims.

# 7 vn / T Calibration and Adjustment

The EE680 can be calibrated /adjusted with the help of the PCS10. For this purpose, the probe needs to be connected to a PC via a Modbus configuration adapter.

### Definitions

- **Calibration** documents the accuracy of a measurement device. The device under test (specimen) is compared with the reference and the deviations are documented in a calibration certificate. During the calibration, the specimen is not changed or improved in any way.
- **Adjustment** improves the measurement accuracy of a device. The specimen is compared with the reference and brought in line with it. An adjustment can be followed by a calibration which documents the accuracy of the adjusted specimen.

### **i** PLEASE NOTE

To achieve results comparable to the E+E factory setting, please observe the following instructions:

- The adjustment should be done in a wind tunnel with homogeneous, low turbulent flow profile.
- Insert the probe 10 cm (4") deep into the flow channel.
- The fixtures should be mounted outside the flow channel and should not rise into the air stream.

## 7.1 Selection of Appropriate Adjustment Method

The EE680 can be adjusted in 2 different ways:

- **1-point vn/T adjustment:**  
Quick and easy option for obtaining precise measuring results at a specific working point. 1-point adjustment should only be used for very limited working ranges.
- **2-point vn/T adjustment:**  
With 2-point adjustment, accurate measuring results can be obtained over the entire vn/T measuring range. The more complicated 2-point adjustment procedure is preferable to 1 point adjustment, if higher precision or a wider working range is required.

### 7.1.1. General Information on 1-Point vn/T Adjustment

If possible the selected adjustment point should be similar to the working point (of the limited working range) of the sensor.

Example: Working range vn 0...2 m/s (0...400 ft/min) → adjustment point at 1.0 m/s (200 ft/min);  
working range T 18...22 °C (64.4...71.6 °F) → adjustment point at 20 °C (68 °F).

### 7.1.2. General Information on 2-Point vn/T Adjustment

With 2-point adjustment, vn/T adjustment is performed at 2 different adjustment points.

To ensure the smallest possible deviation in measuring results over the entire measuring range, the two adjustment points should be selected as follows:

- The low adjustment point should be in the lower third of the measuring range. Adjustment shall be performed using the “Low” point in the drop-down.
- The high adjustment point should be in the upper third of the measuring range. Adjustment shall be performed using the “High” point in the drop-down.
- There is also an “Auto” option for adjustment point selection. This option means that the smaller value will automatically be taken as the low adjustment point and the bigger value as the high one.

Example: EE680 - measuring range = 0...2 m/s (0...400 ft/min).

Low adjustment point (V-CAL LOW) should be around 0.4 m/s (0...0.7 m/s) / 79 ft/min (0...138 ft/min).

High adjustment point (V-CAL HIGH) should be around 1.8 m/s (1.4...2 m/s) / 354 ft/min (276...400 ft/min).

## 7.2 Adjustment with PCS10

Please follow the instructions from the PCS10 Product Configuration Software.

## 7.3 Calibration and Adjustment at E+E Elektronik

Calibration and/or adjustment can be performed in the E+E Elektronik calibration laboratory. For information on the E+E capabilities in ISO 17025 or accredited calibration please see [www.eplusecal.com](http://www.eplusecal.com).

For information on the E+E capabilities in ISO 9001 calibration please see [www.epluse.com/iso9001cal](http://www.epluse.com/iso9001cal).

# 8 Accessories

Please also refer to the [Accessories](#) datasheet.

Accessories	Code
Modbus configuration adapter	HA011018
E+E Product Configuration Software (Free Download: <a href="http://www.epluse.com/pcs10">www.epluse.com/pcs10</a> )	PCS10
Protection cap for M12 socket	HA010781
Protection cap for M12 plug	HA010782
Sensor connection cable, shielded, 5 poles, M12x1 socket ↔ wire ferrules	1.5 m (4.9 ft) HA010819 5 m (16.4 ft) HA010820 10 m (32.8 ft) HA010821
Y-Style Splitter, M12x1, 1 Plug ↔ 2 Sockets, 5 poles	HA030204
Connector, M12x1 socket, 5 poles, for self assembly	HA010708
Mounting set for EE680	HA011601
M12 sealing plug for EE680, stainless steel	HA011602

# 9 Technical Data

## Measurands

### Air Velocity (v)

<b>Standard conditions</b> factory setting	pn = 1 013.25 mbar (14.7 psi); Tn = 23 °C (73 °F) Freely configurable via PCS10	
<b>Measuring range</b>	0...2 m/s (0...400 ft/min)	
<b>Accuracy</b> <sup>1)</sup> in air @ 23 °C (73 °F) and 1 013 hPa (14.7 psi)	0.1...2 m/s (20...400 ft/min); ± (0.5 % of mv +0.05 m/s)	mv = measured value
<b>Dependency of inflow angle (α) of inflow direction</b>	<3 % for α < ±10° <3 %	
<b>Response time</b> t <sub>90</sub> , typ.	<1.5...40 s (Factory setting: 1.5 s, configurable via PCS10)	

1) The accuracy statement includes the uncertainty of the factory calibration with an enhancement factor k=2 (2-times standard deviation). The accuracy was calculated in accordance with EA-4/02 and with regard to GUM (Guide to the Expression of Uncertainty in Measurement).

### Temperature (T)

<b>Measuring range</b>	-20...+70 °C (-4...+158 °F)
<b>Accuracy</b> , typ. in air @ 23 °C (73 °F), at air flows ≥ 0.45 m/s	±0.5 °C (±0.9 °F)

## Outputs



### Analogue

<b>Two freely scalable outputs</b>	0 - 5 V / 0 - 10 V 0 - 20 mA (3-wire)/4 - 20 mA (3-wire)	-1 mA < I <sub>L</sub> < 1 mA Load resistance ≤ 350 Ω
------------------------------------	---	--

### Digital

<b>Digital interface</b>	RS485 (EE680 = 1/10 unit load)
<b>Protocol</b> <b>Factory settings</b> <b>Supported Baud rates</b> <b>Measured data types</b>	Modbus RTU 9 600 Baud, 8 data bits, parity even, 1 stop bit, Modbus address 68 9 600, 19 200, 38 400, 57 600, 76 800 and 115 200 FLOAT32 and INT16

## General

<b>Power supply</b> class III  USA & Canada: Class 2 supply necessary	24 V DC ±20 %		
<b>Current consumption</b> , typ.	<30 mA		
<b>Electrical connection</b>	M12x1, 5 poles, stainless steel 1.4404		
<b>Pressure working range</b>	700...1 300 hPa (10.2...18.9 psi)		
<b>Storage conditions</b>	-20...+70 °C (-4...+158 °F) 0...95 %RH, non-condensing		
<b>Enclosure material</b>	Stainless steel 1.4404		
<b>Protection rating</b>	IP65		
<b>Electromagnetic compatibility</b>	EN 61326-1 FCC Part15 Class A	EN 61326-2-3 ICES-003 Class A	Industrial environment
<b>Conformity</b>	 		
<b>Configuration and adjustment</b>	PCS10 Product Configuration Software ( <a href="#">free download</a> ) and configuration adapter		

# 10 Conformity

## 10.1 Declarations of Conformity

E+E Elektronik Ges.m.b.H. hereby declares that the product complies with the respective regulations listed below:



European directives and standards.

and



UK statutory instruments and designated standards.

Please refer to the product page at [www.epluse.com/ee680](http://www.epluse.com/ee680) for the Declarations of Conformity.

## 10.2 Electromagnetic Compatibility

EMC for industrial environment.

The probe is a group 1 device and corresponds to class A.

### WARNING

This device is not intended for use in residential areas and cannot ensure adequate protection of radio reception in such environments.

## 10.3 FCC Part 15 Compliance Statement

This equipment has been tested and found to comply with the limits for a Class A digital device, pursuant to part 15 of the FCC Rules. These limits are designed to provide reasonable protection against harmful interference when the equipment is operated in a commercial environment. This equipment generates, uses, and can radiate radio frequency energy and, if not installed and used in accordance with the instruction manual, may cause harmful interference to radio communications. Operation of this equipment in a residential area is likely to cause harmful interference in which case the user will be required to correct the interference at his own expense.

## 10.4 ICES-003 Compliance Statement

This Class A digital apparatus complies with Canadian ICES-003.

Cet appareil numérique de la classe A est conforme à la norme NMB-003 du Canada.

# 11 Recycling of the Device

### PLEASE NOTE

Products from E+E Elektronik Ges.m.b.H. are developed and manufactured in compliance with relevant environmental protection requirements. Please observe local regulations for the disposal of the device.



For disposal, the individual components of the device must be separated according to local recycling regulations. The electronics shall be disposed of correctly as electronics waste.

**Probe**

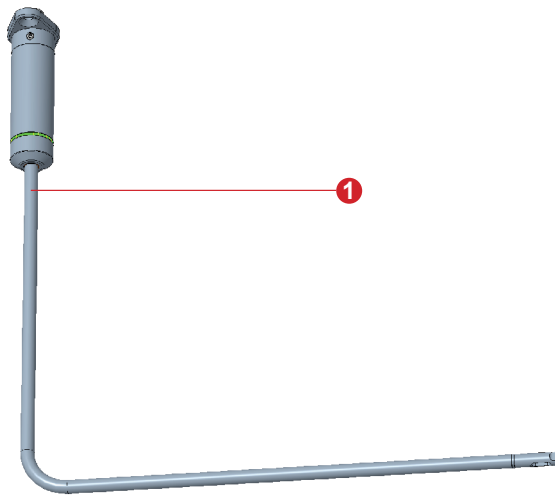

Fig. 11 Probe

No.	Part	Material	Recycling Type
1	Probe	Various materials	Electrical and Electronics waste

Tab. 14 Recycling of EE680 probe

**i PLEASE NOTE**

Fig. 11 shows the stainless steel mounting flange which is not an integral part of the EE680 probe. Please refer to the section below for recycling instruction.

**Stainless Steel Mounting Flange**

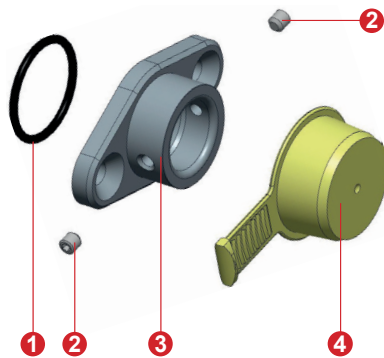
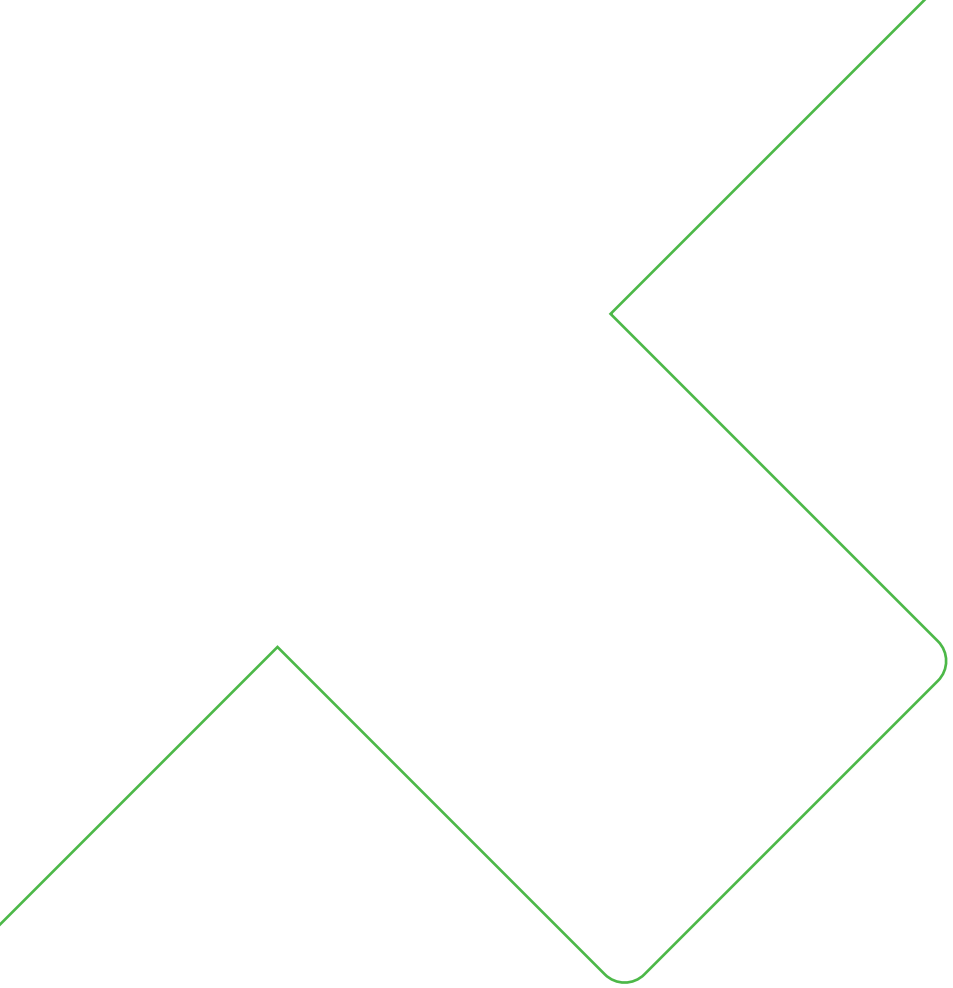

Fig. 12 Mounting flange

No.	Part	Material	Recycling Type
1	Seal	Neoprene	Plastics waste
2	Screws	Stainless steel	Metal waste
3	Flange	Stainless steel	Metal waste
4	Protection cap	Plastic	Plastics waste

Tab. 15 Recycling of the stainless steel mounting flange



Company Headquarters &  
Production Site

**E+E Elektronik Ges.m.b.H.**  
Langwiesen 7  
4209 Engerwitzdorf | Austria  
T +43 7235 605-0  
F +43 7235 605-8  
info@epluse.com  
www.epluse.com

Subsidiaries

**E+E Sensor Technology (Shanghai) Co., Ltd.**  
T +86 21 6117 6129  
info@epluse.cn

**E+E Elektronik France SARL**  
T +33 4 74 72 35 82  
info.fr@epluse.com

**E+E Elektronik Deutschland GmbH**  
T +49 6171 69411-0  
info.de@epluse.com

**E+E Elektronik India Private Limited**  
T +91 990 440 5400  
info.in@epluse.com

**E+E Elektronik Italia S.r.l.**  
T +39 02 2707 86 36  
info.it@epluse.com

**E+E Elektronik Korea Ltd.**  
T +82 31 732 6050  
info.kr@epluse.com

**E+E Elektronik Corporation**  
T +1 847 490 0520  
info.us@epluse.com



—  
your partner  
in sensor  
technology.