

## OPTIFLUX 5000 Handbook

Electromagnetic flowmeter in sandwich version

The documentation is only complete when used in combination with the relevant documentation for the signal converter.

All rights reserved. It is prohibited to reproduce this documentation, or any part thereof, without the prior written authorisation of KROHNE Messtechnik GmbH.

Subject to change without notice.

Copyright 2017 by  
KROHNE Messtechnik GmbH - Ludwig-Krohne-Str. 5 - 47058 Duisburg (Germany)

<b>1</b>	<b>Safety instructions</b>	<b>5</b>
1.1	Intended use .....	5
1.2	Certification .....	5
1.3	Safety instructions from the manufacturer .....	6
1.3.1	Copyright and data protection .....	6
1.3.2	Disclaimer .....	6
1.3.3	Product liability and warranty .....	7
1.3.4	Information concerning the documentation .....	7
1.3.5	Warnings and symbols used .....	8
1.4	Safety instructions for the operator .....	8
<b>2</b>	<b>Device description</b>	<b>9</b>
2.1	Scope of delivery .....	9
2.2	Device description .....	10
2.3	Nameplates (examples) .....	11
<b>3</b>	<b>Installation</b>	<b>12</b>
3.1	General notes on installation .....	12
3.2	Storage .....	12
3.3	Transport .....	12
3.4	Pre-installation requirements .....	12
3.5	General requirements .....	13
3.5.1	Vibration .....	13
3.5.2	Magnetic field .....	13
3.6	Installation conditions .....	14
3.6.1	Inlet and outlet .....	14
3.6.2	Bends in 2 or 3 dimensions .....	14
3.6.3	T-section .....	15
3.6.4	Bends .....	15
3.7	Open feed or discharge .....	16
3.8	Flange deviation .....	16
3.9	Control valve .....	16
3.10	Pump .....	17
3.11	Air venting and vacuum forces .....	17
3.12	Mounting position .....	18
3.13	Mounting .....	19
3.13.1	Torques and pressure .....	19

4 Electrical connections	21
4.1 Safety instructions.....	21
4.2 Grounding .....	21
4.3 Virtual reference for IFC 300 (C, W and F version) .....	22
4.4 Connection diagrams .....	22
5 Service	23
5.1 Spare parts availability.....	23
5.2 Availability of services .....	23
5.3 Returning the device to the manufacturer.....	23
5.3.1 General information.....	23
5.3.2 Form (for copying) to accompany a returned device.....	24
5.4 Disposal .....	24
6 Technical data	25
6.1 Measuring principle.....	25
6.2 Technical data.....	26
6.3 Measuring accuracy .....	31
6.4 Dimensions and weights .....	33
7 Notes	37

## 1.1 Intended use

**CAUTION!**

*Responsibility for the use of the measuring devices with regard to suitability, intended use and corrosion resistance of the used materials against the measured fluid lies solely with the operator.*

**INFORMATION!**

*The manufacturer is not liable for any damage resulting from improper use or use for other than the intended purpose.*

The **OPTIFLUX 5000** flowmeter measures the volumetric flow rate of electrically conductive liquids, acids, alkaline solutions, pastes and slurries, also with very high solid contents.

## 1.2 Certification

CE marking



The manufacturer certifies successful testing of the product by applying the CE marking.

**This device fulfils the statutory requirements of the relevant EU directives.**

For full information of the EU directives and standards and the approved certifications, please refer to the EU Declaration of Conformity or the website of the manufacturer.

**DANGER!**

*For devices used in hazardous areas, additional safety notes apply. Please refer to the Ex documentation.*

## 1.3 Safety instructions from the manufacturer

### 1.3.1 Copyright and data protection

The contents of this document have been created with great care. Nevertheless, we provide no guarantee that the contents are correct, complete or up-to-date.

The contents and works in this document are subject to copyright. Contributions from third parties are identified as such. Reproduction, processing, dissemination and any type of use beyond what is permitted under copyright requires written authorisation from the respective author and/or the manufacturer.

The manufacturer tries always to observe the copyrights of others, and to draw on works created in-house or works in the public domain.

The collection of personal data (such as names, street addresses or e-mail addresses) in the manufacturer's documents is always on a voluntary basis whenever possible. Whenever feasible, it is always possible to make use of the offerings and services without providing any personal data.

We draw your attention to the fact that data transmission over the Internet (e.g. when communicating by e-mail) may involve gaps in security. It is not possible to protect such data completely against access by third parties.

We hereby expressly prohibit the use of the contact data published as part of our duty to publish an imprint for the purpose of sending us any advertising or informational materials that we have not expressly requested.

### 1.3.2 Disclaimer

The manufacturer will not be liable for any damage of any kind by using its product, including, but not limited to direct, indirect or incidental and consequential damages.

This disclaimer does not apply in case the manufacturer has acted on purpose or with gross negligence. In the event any applicable law does not allow such limitations on implied warranties or the exclusion of limitation of certain damages, you may, if such law applies to you, not be subject to some or all of the above disclaimer, exclusions or limitations.

Any product purchased from the manufacturer is warranted in accordance with the relevant product documentation and our Terms and Conditions of Sale.

The manufacturer reserves the right to alter the content of its documents, including this disclaimer in any way, at any time, for any reason, without prior notification, and will not be liable in any way for possible consequences of such changes.

### 1.3.3 Product liability and warranty

The operator shall bear responsibility for the suitability of the device for the specific purpose. The manufacturer accepts no liability for the consequences of misuse by the operator. Improper installation or operation of the devices (systems) will cause the warranty to be void. The respective "Standard Terms and Conditions" which form the basis for the sales contract shall also apply.

### 1.3.4 Information concerning the documentation

To prevent any injury to the user or damage to the device it is essential that you read the information in this document and observe applicable national standards, safety requirements and accident prevention regulations.

If this document is not in your native language and if you have any problems understanding the text, we advise you to contact your local office for assistance. The manufacturer can not accept responsibility for any damage or injury caused by misunderstanding of the information in this document.

This document is provided to help you establish operating conditions, which will permit safe and efficient use of this device. Special considerations and precautions are also described in the document, which appear in the form of icons as shown below.

### 1.3.5 Warnings and symbols used

Safety warnings are indicated by the following symbols.



**DANGER!**

*This warning refers to the immediate danger when working with electricity.*



**DANGER!**

*This warning refers to the immediate danger of burns caused by heat or hot surfaces.*



**DANGER!**

*This warning refers to the immediate danger when using this device in a hazardous atmosphere.*



**DANGER!**

*These warnings must be observed without fail. Even partial disregard of this warning can lead to serious health problems and even death. There is also the risk of seriously damaging the device or parts of the operator's plant.*



**WARNING!**

*Disregarding this safety warning, even if only in part, poses the risk of serious health problems. There is also the risk of damaging the device or parts of the operator's plant.*



**CAUTION!**

*Disregarding these instructions can result in damage to the device or to parts of the operator's plant.*



**INFORMATION!**

*These instructions contain important information for the handling of the device.*



**LEGAL NOTICE!**

*This note contains information on statutory directives and standards.*



• **HANDLING**

This symbol designates all instructions for actions to be carried out by the operator in the specified sequence.

➔ **RESULT**

This symbol refers to all important consequences of the previous actions.

## 1.4 Safety instructions for the operator



**WARNING!**

*In general, devices from the manufacturer may only be installed, commissioned, operated and maintained by properly trained and authorized personnel.*

*This document is provided to help you establish operating conditions, which will permit safe and efficient use of this device.*



## 2.1 Scope of delivery



**INFORMATION!**

Do a check of the packing list to make sure that you have all the elements given in the order.



**INFORMATION!**

Inspect the packaging carefully for damages or signs of rough handling. Report damage to the carrier and to the local office of the manufacturer.



**INFORMATION!**

The remote version will arrive in two cartons. One carton contains the converter and one carton contains the sensor.

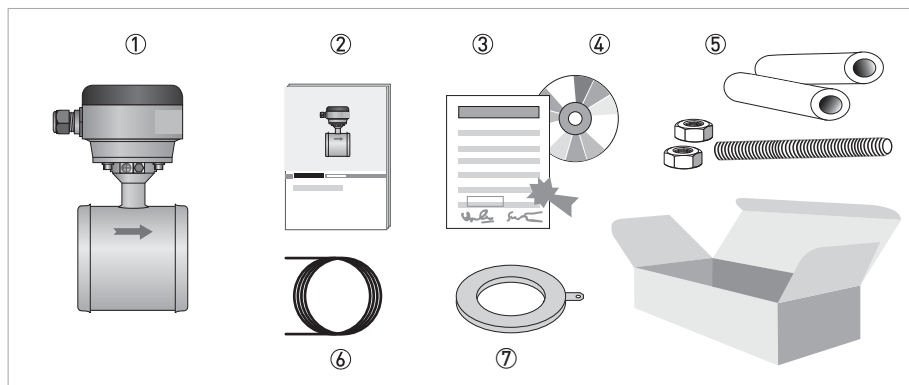

Figure 2-1: Scope of delivery

- ① Ordered flowmeter
- ② Product documentation
- ③ Factory calibration report
- ④ CD-ROM with product documentation in available languages
- ⑤ Mounting material (rubber sleeves). Optional; studs and bolts.
- ⑥ Signal cable (remote versions only)
- ⑦ Grounding rings (optional)



**INFORMATION!**

Assembly materials and tools are not part of the delivery. Use the assembly materials and tools in compliance with the applicable occupational health and safety directives.

## 2.2 Device description

Electromagnetic flowmeters are designed exclusively to measure the flow and conductivity of electrically conductive, liquid media.

Your measuring device is supplied ready for operation. The factory settings for the operating data have been made in accordance with your order specifications.



### INFORMATION!

Product specific information and extensive product specification is available using PICK, the Product Information Center KROHNE web-tool.

PICK can be found via the service menu button on the KROHNE.com website.



### The following versions are available:

- Compact version (the signal converter is mounted directly on the measuring sensor)
- Remote version (a measuring sensor with connection box and a separate signal converter)

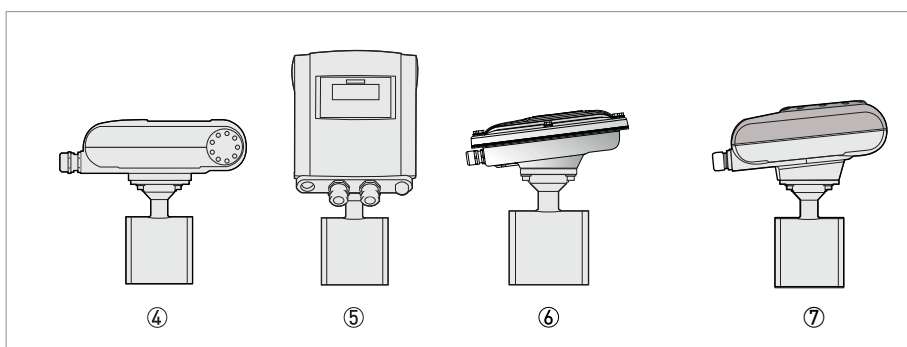
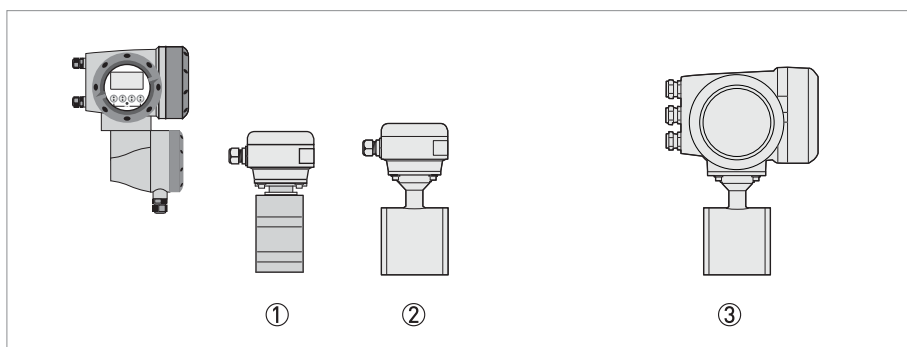

- ① Remote version (DN2.5...15)
- ② Remote version (DN25...100)
- ③ Compact version with IFC 300 signal converter
- ④ Compact version with IFC 100 (0°) signal converter
- ⑤ Compact version with IFC 100 (45°) signal converter
- ⑥ Compact version with IFC 100 stainless steel (10°) signal converter
- ⑦ Compact version with IFC 050 (10°) signal converter

## 2.3 Nameplates (examples)



### **INFORMATION!**

Look at the device nameplate to ensure that the device is delivered according to your order.  
Check for the correct supply voltage printed on the nameplate.

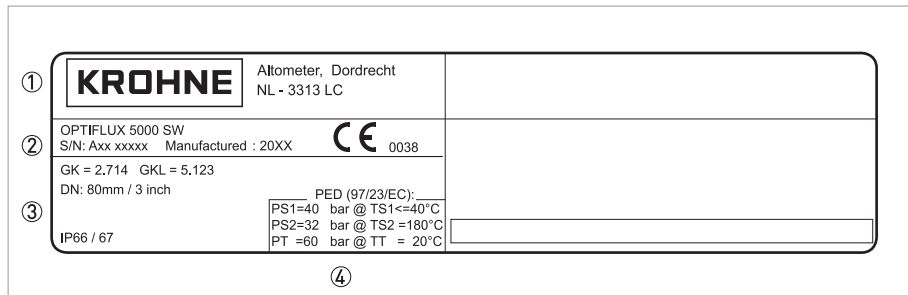

- ① Name and address of the manufacturer
- ② Type designation of the flowmeter and CE sign with number(s) of notified body / bodies
- ③ Calibration data
- ④ PED data

### 3.1 General notes on installation



**INFORMATION!**

Inspect the packaging carefully for damages or signs of rough handling. Report damage to the carrier and to the local office of the manufacturer.



**INFORMATION!**

Do a check of the packing list to make sure that you have all the elements given in the order.



**INFORMATION!**

Look at the device nameplate to ensure that the device is delivered according to your order. Check for the correct supply voltage printed on the nameplate.

### 3.2 Storage

- Store the device in a dry and dust-free location.
- Avoid lasting direct exposure to the sun.
- Store the device in its original packaging.
- Storage temperature: -50...+70°C / -58...+158°F

### 3.3 Transport

#### Signal converter

- No special requirements.

#### Compact version

- Do not lift the device by the signal converter housing.
- Do not use lifting chains.
- To transport the device, use lifting straps.



Figure 3-1: Transport

## 3.4 Pre-installation requirements

Make sure that you have all necessary tools available:

- Allen key (4 mm)
- Small screwdriver
- Wrench for cable glands
- Wrench for wall mounting bracket (remote version only)
- Torque wrench for installing flowmeter in pipeline

## 3.5 General requirements



### **INFORMATION!**

The following precautions must be taken to ensure reliable installation.

- Make sure that there is adequate space to the sides.
- Protect the signal converter from direct sunlight and install a sun shade if necessary.
- Signal converters installed in control cabinets require adequate cooling, e.g. by fan or heat exchanger.
- Do not expose the signal converter to intense vibration. The flowmeters are tested for a vibration level in accordance with IEC 68-2-64.

### 3.5.1 Vibration

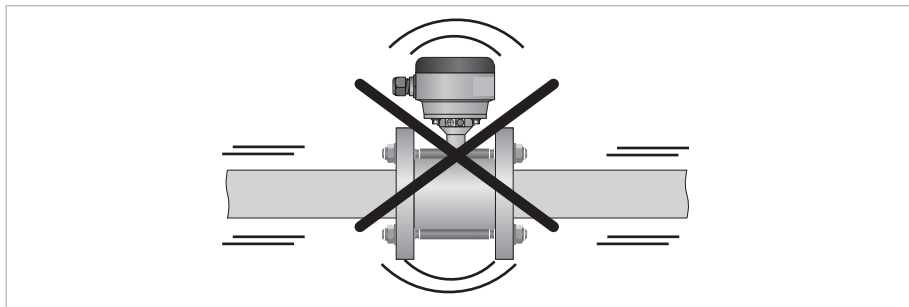

Figure 3-2: Avoid vibrations

### 3.5.2 Magnetic field

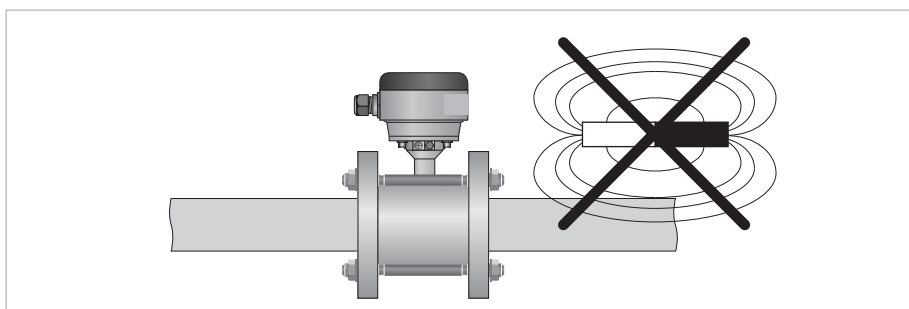

Figure 3-3: Avoid magnetic fields

## 3.6 Installation conditions

### 3.6.1 Inlet and outlet

Use straight inlet and outlet pipe sections to prevent flow distortion or swirl, caused by bends and T-sections.

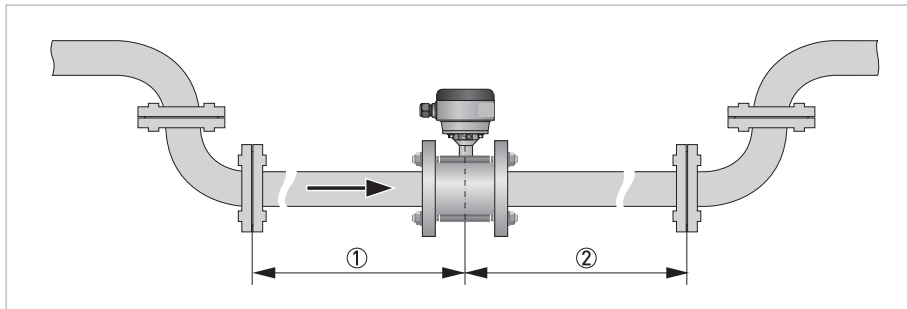

Figure 3-4: Recommended inlet and outlet section

- ① Refer to chapter "Bends in 2 or 3 dimensions"
- ②  $\geq 2$  DN

### 3.6.2 Bends in 2 or 3 dimensions

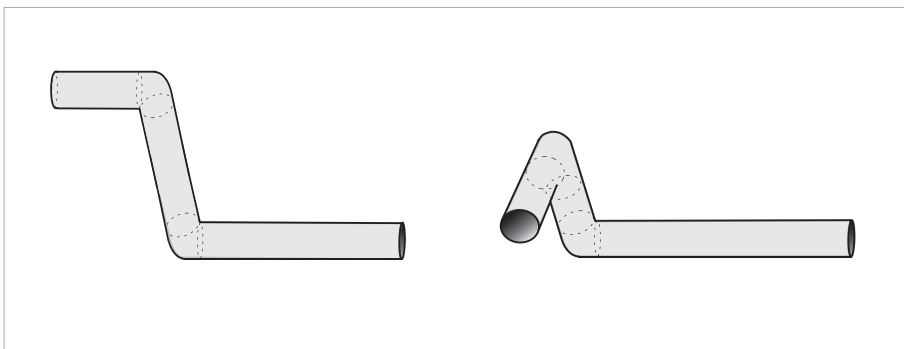

Figure 3-5: Inlet when using 2 and/or 3 dimensional bends upstream of the flowmeter

Inlet length: using bends in 2 dimensions:  $\geq 5$  DN; when having bends in 3 dimensions:  $\geq 10$  DN



**INFORMATION!**

*2 Dimensional bends occur in a vertical **or** horizontal plane only, while 3 Dimensional bends occur in both vertical **and** horizontal plane.*

### 3.6.3 T-section

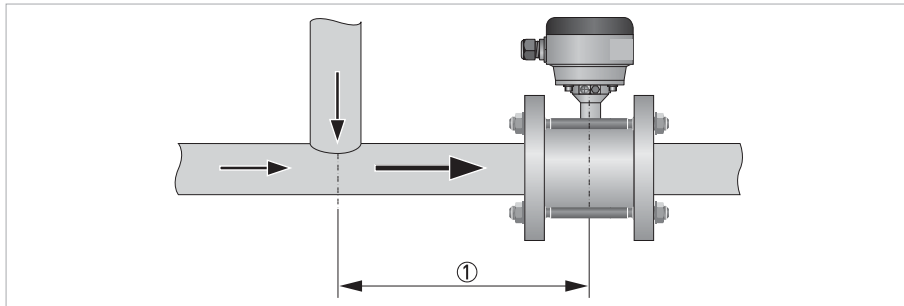
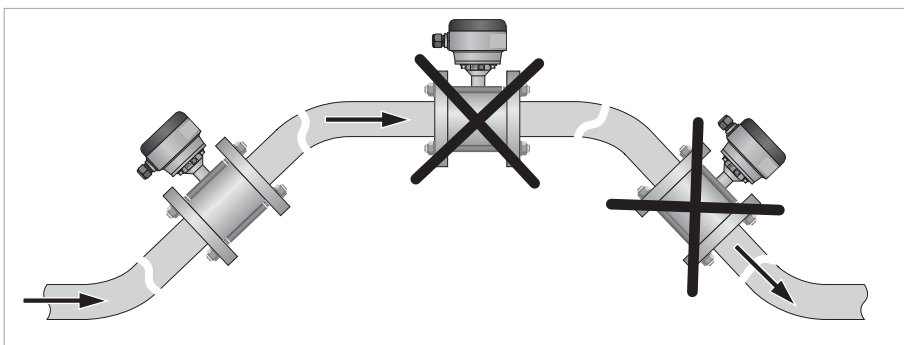
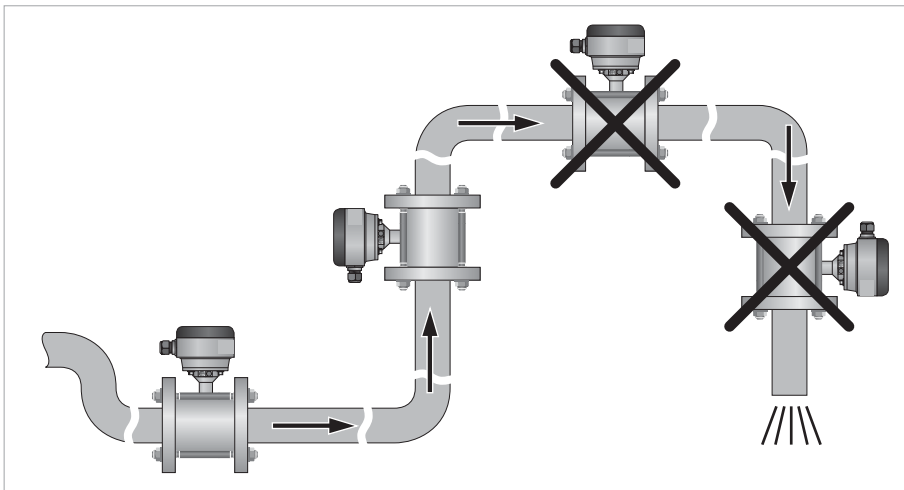

Figure 3-6: Distance behind a T-section

①  $\geq 10$  DN

### 3.6.4 Bends



**CAUTION!**  
Avoid draining or partial filling of the flow sensor

### 3.7 Open feed or discharge

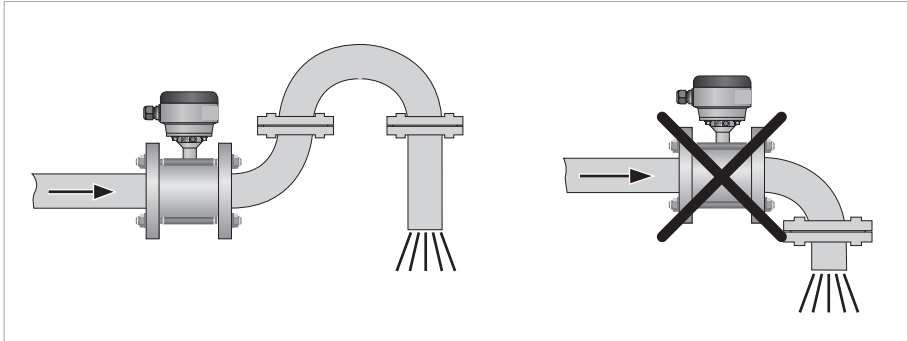

Figure 3-7: Installation in front of an open discharge

### 3.8 Flange deviation



**CAUTION!**

Max. permissible deviation of pipe flange faces:

$$L_{max} - L_{min} \leq 0.5 \text{ mm} / 0.02''$$

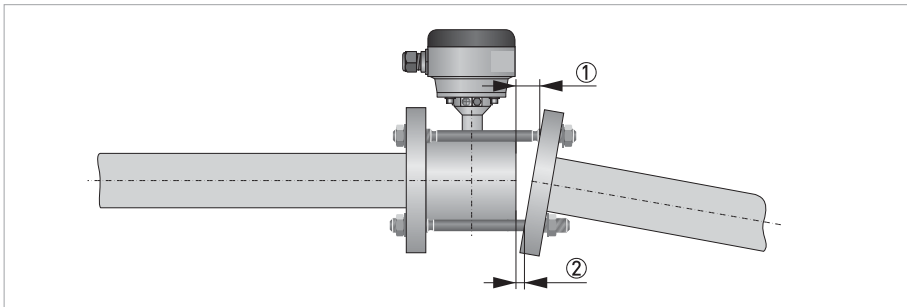

Figure 3-8: Flange deviation

- ①  $L_{max}$
- ②  $L_{min}$

### 3.9 Control valve

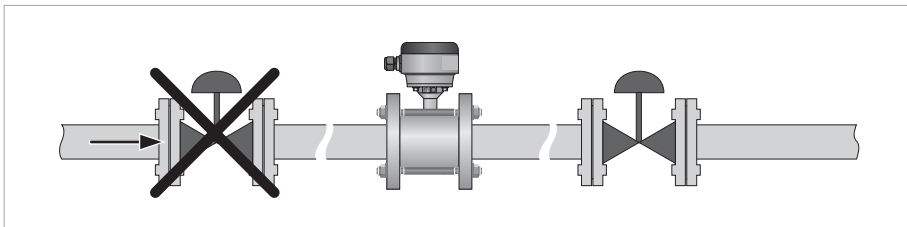

Figure 3-9: Installation in front of a control valve



### 3.10 Pump

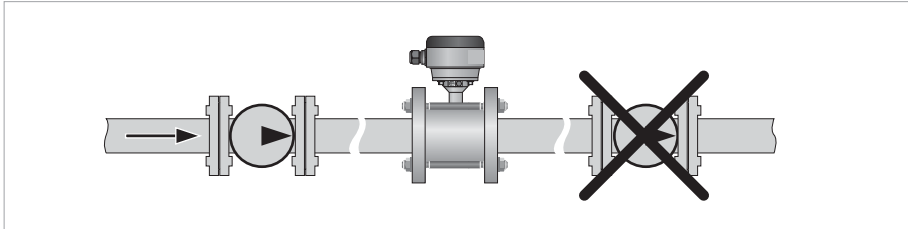

Figure 3-10: Installation behind a pump

### 3.11 Air venting and vacuum forces

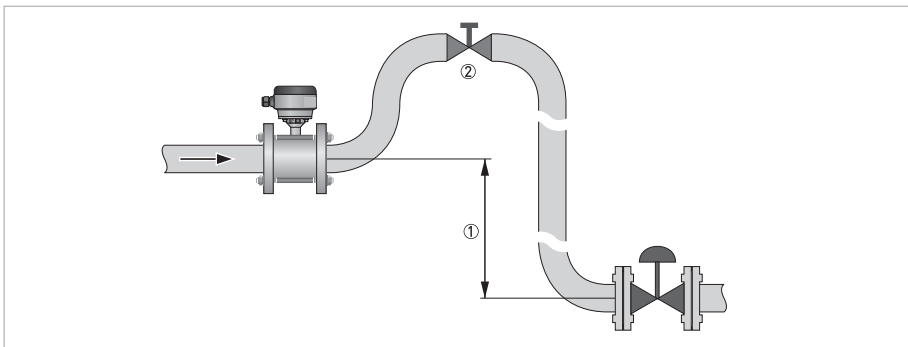

Figure 3-11: Air venting

- ①  $\geq 5$  m / 17 ft
- ② Air ventilation point

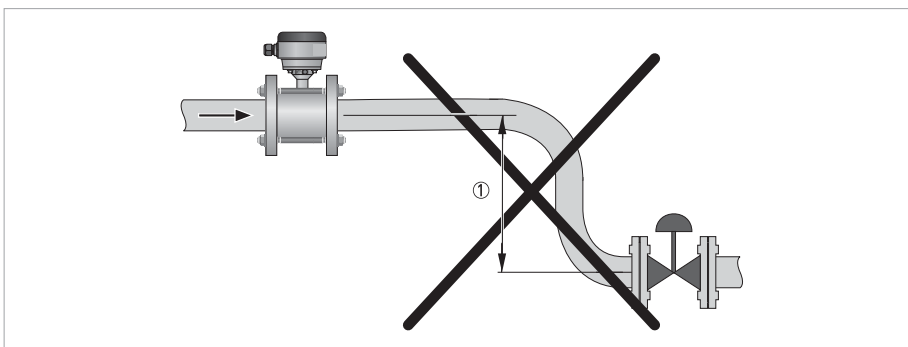

Figure 3-12: Vacuum

- ①  $\geq 5$  m / 17 ft

### 3.12 Mounting position

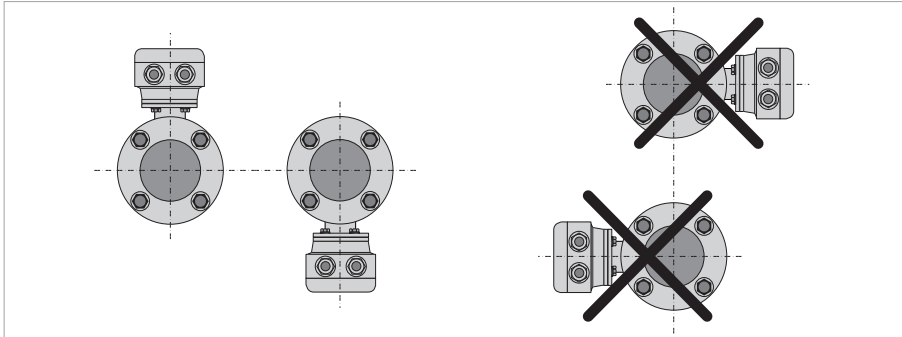

Figure 3-13: Mounting position

- Install flow sensor in line with the pipe axis.
- Pipe flange faces must be parallel to each other.

### 3.13 Mounting

#### 3.13.1 Torques and pressure



**WARNING!**

- Please use stainless steel A2 / 6.9 class bolts.
- Make sure the connecting flanges are of type raised face (RF).

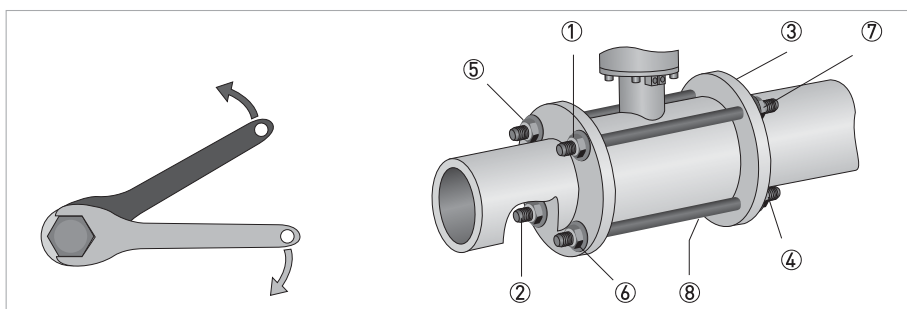

Figure 3-14: Tighten the bolts in fixed order, see picture.

**Max. torque:**

- Step 1: approx. 50% of max. torque
- Step 2: approx. 80% of max. torque
- Step 3: 100% of max. torque given in tables

**EN 1092-1**

Nominal size DN [mm]	Pressure rating	Max. allowable operating pressure [bar]
2.5...80	PN 40	40
100	PN 16	16
100	PN 25	25

**ASME B 16.5**

Nominal size [inch]	Pressure rating	Max. allowable operating pressure [psig]
1/10...4"	150 lb	230
1/10...3"	300 lb	580



**CAUTION!**

- Pressures at 20°C / 68°F.
- For higher temperatures, the pressure and temperature ratings are as per ASME B16.5.

**INFORMATION!**

The specified torque values are dependent on variables (temperature, bolt material, gasket material, lubricants, etc.) which are not within the control of the manufacturer. Therefore the values should be regarded as indicative only.

**EN 1092-1**

Nominal size DN [mm]	Counter flanges & bolts		Max. allowable torque					
			Gasket: Filled PTFE / PTFE / PF29		Gasket: Graphite		O-ring	
	Rating	Size	Nm	ftlb	Nm	ftlb	Nm	ftlb
2.5...10	PN 40	M12 x 141	-	-	-	-	32	24
15	PN 40	M12 x 141	-	-	-	-	36	27
25	PN 40	M12 x 141	22	16	32	24	-	-
40	PN 40	M16 x 176	47	35	66	49	-	-
50	PN 40	M16 x 203	58	43	82	60	-	-
80	PN 40	M16 x 261	48	35	69	51	-	-
100	PN 16	M16 x 303	75	55	106	78	-	-
100	PN 25	M20 x 176	94	69	133	98	-	-

**ASME B 16.5**

Nominal size [inch]	Counter flanges & bolts		Max. allowable torque					
			Gaskets: Filled PTFE/ PTFE / PF29		Gaskets: Graphite		O-ring	
	Rating	Size	Nm	ftlb	Nm	ftlb	Nm	ftlb
1/10...3/8 "	150 lb	1/2"UNC x 142	-	-	-	-	35	26
1/2"	150 lb	1/2"UNC x 142	-	-	-	-	35	26
1"	150 lb	1/2"UNC x 142	24	18	33	24	-	-
1 1/2"	150 lb	1/2"UNC x 174	38	28	54	40	-	-
2"	150 lb	5/8"UNC x 215	58	43	83	61	-	-
3"	150 lb	5/8"UNC x 268	98	72	138	102	-	-
4"	150 lb	5/8"UNC x 318	75	55	108	80	-	-

## 4.1 Safety instructions



**DANGER!**

All work on the electrical connections may only be carried out with the power disconnected. Take note of the voltage data on the nameplate!



**DANGER!**

Observe the national regulations for electrical installations!



**DANGER!**

For devices used in hazardous areas, additional safety notes apply; please refer to the Ex documentation.



**WARNING!**

Observe without fail the local occupational health and safety regulations. Any work done on the electrical components of the measuring device may only be carried out by properly trained specialists.



**INFORMATION!**

Look at the device nameplate to ensure that the device is delivered according to your order. Check for the correct supply voltage printed on the nameplate.

## 4.2 Grounding



**DANGER!**

The device must be grounded in accordance with regulations in order to protect personnel against electric shocks.

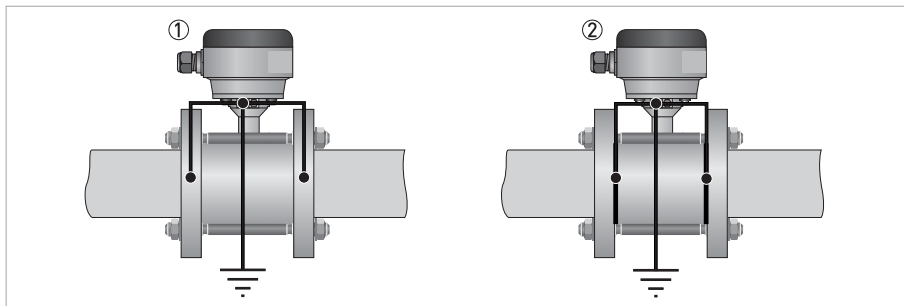

Figure 4-1: Grounding

- ① Metal pipelines, not internally coated. Grounding without grounding rings!
- ② Metal pipelines with internal coating and non-conductive pipelines. Grounding with grounding rings!



Figure 4-2: Grounding ring number 1

**Grounding ring number 1 (optional for DN25...150 / 1...6"):** Thickness: 3 mm / 0.1" (tantalum: 0.5 mm / 0.02")



**INFORMATION!**

For diameter DN10 / 3/8" and DN15 / 1/2", grounding rings are integrated as standard in the flow sensor construction.

### 4.3 Virtual reference for IFC 300 (C, W and F version)

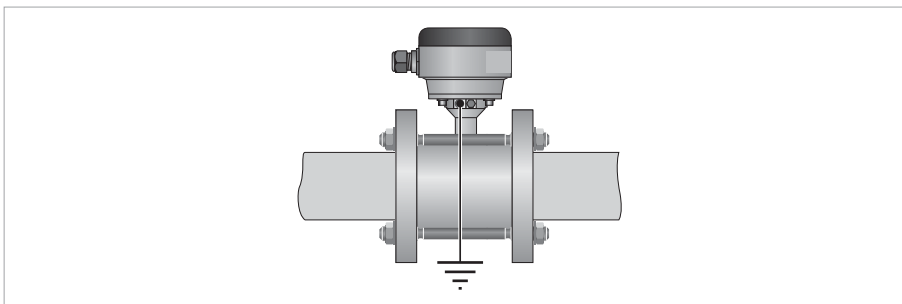

Figure 4-3: Virtual reference

**Minimum requirements:**

- Size:  $\geq$  DN10 / 3/8"
- Electrical conductivity:  $\geq$  200  $\mu$ S/cm
- Signal cable: max. 50 m / 164 ft, type DS

### 4.4 Connection diagrams



**INFORMATION!**

For the connection diagrams please refer to the documentation of the applicable signal converter.

## 5.1 Spare parts availability

The manufacturer adheres to the basic principle that functionally adequate spare parts for each device or each important accessory part will be kept available for a period of 3 years after delivery of the last production run for the device.

This regulation only applies to spare parts which are subject to wear and tear under normal operating conditions.

## 5.2 Availability of services

The manufacturer offers a range of services to support the customer after expiration of the warranty. These include repair, maintenance, technical support and training.



### **INFORMATION!**

*For more precise information, please contact your local sales office.*

## 5.3 Returning the device to the manufacturer

### 5.3.1 General information

This device has been carefully manufactured and tested. If installed and operated in accordance with these operating instructions, it will rarely present any problems.



### **CAUTION!**

*Should you nevertheless need to return a device for inspection or repair, please pay strict attention to the following points:*

- *Due to statutory regulations on environmental protection and safeguarding the health and safety of the personnel, the manufacturer may only handle, test and repair returned devices that have been in contact with products without risk to personnel and environment.*
- *This means that the manufacturer can only service this device if it is accompanied by the following certificate (see next section) confirming that the device is safe to handle.*



### **CAUTION!**

*If the device has been operated with toxic, caustic, radioactive, flammable or water-endangering products, you are kindly requested:*

- *to check and ensure, if necessary by rinsing or neutralising, that all cavities are free from such dangerous substances,*
- *to enclose a certificate with the device confirming that it is safe to handle and stating the product used.*

### 5.3.2 Form (for copying) to accompany a returned device



**CAUTION!**

*To avoid any risk for our service personnel, this form has to be accessible from outside of the packaging with the returned device.*

Company:		Address:	
Department:		Name:	
Tel. no.:		Fax no. and/or Email address:	
Manufacturer's order no. or serial no.:			
The device has been operated with the following medium:			
This medium is:	<input type="checkbox"/>	radioactive	
	<input type="checkbox"/>	water-hazardous	
	<input type="checkbox"/>	toxic	
	<input type="checkbox"/>	caustic	
	<input type="checkbox"/>	flammable	
	<input type="checkbox"/>	We checked that all cavities in the device are free from such substances.	
<input type="checkbox"/>	We have flushed out and neutralized all cavities in the device.		
We hereby confirm that there is no risk to persons or the environment through any residual media contained in the device when it is returned.			
Date:		Signature:	
Stamp:			

### 5.4 Disposal



**CAUTION!**

*Disposal must be carried out in accordance with legislation applicable in your country.*

**Separate collection of WEEE (Waste Electrical and Electronic Equipment) in the European Union:**



According to the directive 2012/19/EU, the monitoring and control instruments marked with the WEEE symbol and reaching their end-of-life **must not be disposed of with other waste**.

The user must dispose of the WEEE to a designated collection point for the recycling of WEEE or send them back to our local organisation or authorised representative.



## 6.1 Measuring principle

An electrically conductive fluid flows inside an electrically insulated pipe through a magnetic field. This magnetic field is generated by a current, flowing through a pair of field coils.

Inside of the fluid, a voltage  $U$  is generated:

$$U = v * k * B * D$$

in which:

$v$  = mean flow velocity

$k$  = factor correcting for geometry

$B$  = magnetic field strength

$D$  = inner diameter of flowmeter

The signal voltage  $U$  is picked off by electrodes and is proportional to the mean flow velocity  $v$  and thus the flow rate  $Q$ . A signal converter is used to amplify the signal voltage, filter it and convert it into signals for totalizing, recording and output processing.

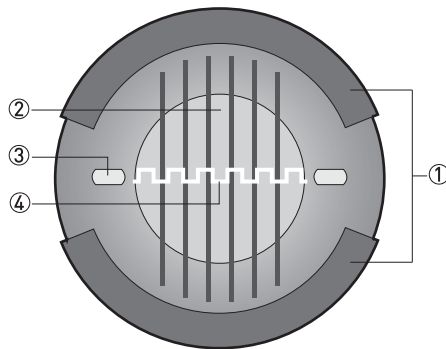

Figure 6-1: Measuring principle

- ① Field coils
- ② Magnetic field
- ③ Electrodes
- ④ Induced voltage (proportional to flow velocity)

## 6.2 Technical data



### INFORMATION!

- The following data is provided for general applications. If you require data that is more relevant to your specific application, please contact us or your local sales office.
- Additional information (certificates, special tools, software,...) and complete product documentation can be downloaded free of charge from the website (Downloadcenter).

### Measuring system

Measuring principle	Faraday's law
Application range	Electrically conductive fluids
<b>Measured value</b>	
Primary measured value	Flow velocity
Secondary measured value	Volume flow, mass flow, electrical conductivity, coil temperature

### Design

Features	Sandwich version with optimized flow tube
Modular construction	The measurement system consists of a flow sensor and a signal converter. It is available as compact and as separate version. More information about the signal converter can be found in the documentation of the signal converter.
Compact version	With IFC 050 converter : OPTIFLUX 5050 C
	With IFC 100 converter : OPTIFLUX 5100 C
	With IFC 300 converter: OPTIFLUX 5300 C DN2.5...15 / 1/10...1/2" is only available with aluminum converter housing
Remote version	In wall (W) mount version with IFC 050 converter : OPTIFLUX 5050 W
	In wall (W) mount version with IFC 100 converter : OPTIFLUX 5100 W
	In field (F), wall (W) or rack (R) mount version with IFC 300 converter : OPTIFLUX 5300 F, W or R
Nominal diameter	DN2.5...100 / 1/10...4"

### Measuring accuracy

Maximum measuring error	IFC 050: down to 0.5% of the measured value $\pm 1$ mm/s
	IFC 100: down to 0.3% of the measured value $\pm 1$ mm/s
	IFC 300: down to 0.15% of the measured value $\pm 1$ mm/s
	The maximum measuring error depends on the installation conditions.
	For detailed information refer to <i>Measuring accuracy</i> on page 31.
Repeatability	$\pm 0.1\%$ of MV, minimum 1 mm/s
Calibration	<b>Standard:</b> 2 point calibration by direct volume comparison. <b>Optional:</b> special calibration on request.

## Operating conditions

<b>Temperature</b>	
Process temperature	Compact version: -40...+140°C / -40... +284°F Size DN 2.5...15 / 1/10...1/2": -20...+120°C / -4... +248°F
	Remote version: -40...+180°C / -40...+356°F Size DN 2.5...15 / 1/10...1/2": -20...+180°C / -4... +356°F
	For Ex versions different temperature ranges are applicable. Please see the relevant Ex documentation for details.
Maximum temperature change (shock)	DN2.5...25 / 1/10...1": < 3 K/s DN40...100 / 1 1/2...4": < 0.2 K/s
Ambient temperature	-40...+65°C / -40...+149°F For IFC 100 SS (stainless steel): -40...+60°C / -40...+140°F
	For Ex versions different temperature ranges are applicable. Please see the relevant Ex documentation for details.
Storage temperature	-50...+70°C / -58...+158°F
<b>Measurement range</b>	-12...+12 m/s / -40...+40 ft/s
<b>Pressure</b>	
Ambient	Atmospheric
<b>Nominal flange pressure</b>	
EN 1092-1	<b>Standard:</b>
	DN100: PN 16
	DN2.5...80: PN 40
	<b>Option:</b>
DN100: PN 25	
ASME B16.5	<b>Standard:</b>
	1/10...4": 150 lb
	<b>Option:</b>
	1/10...4": 300 lb
Vacuum load	0 mbar / 0 psi
Pressure ranges for secondary containment	Pressure resistant up to 40 bar / 580 psi
	Burst pressure up to ~ 160 bar / 2320 psi
<b>Chemical properties</b>	
Physical condition	Liquids
Electrical conductivity	<b>Non water:</b>
	DN25...100 / 1...4": $\geq 1 \mu\text{S/cm}$
	DN4...15 / 3/8...1/2": $\geq 5 \mu\text{S/cm}$
	DN2.5 / 1/10": $\geq 10 \mu\text{S/cm}$
	<b>Demineralised cold water:</b>
DN2.5...100 / 1/10...4": $\geq 20 \mu\text{S/cm}$	
Permissible gas content (volume)	$\leq 5\%$
Permissible solid content (volume)	IFC 050: $\leq 10\%$
	IFC 100: $\leq 10\%$
	IFC 300: $\leq 70\%$

### Installation conditions

Installation	Take care that flow sensor always fully filled.
	For detailed information refer to <i>Installation</i> on page 12.
Flow direction	Forward and reverse.
	Arrow on flow sensor indicates positive flow direction.
Inlet run	≥ 5 DN (without disturbing flow, after a single 90° bend)
	≥ 10 DN (after a double bend = 2 x 90° )
Outlet run	≥ 2 DN
Dimensions and weights	For detailed information refer to <i>Dimensions and weights</i> on page 33.

### Materials

Sensor housing	DN2.5...15 / 1/10...1/2": stainless steel 1.4408 / 316
	DN25...100 / 1...4": stainless steel 1.4306 / 304L
Measuring tube	Ceramic
Connection box (remote versions only)	<b>Standard:</b> Polyurethane coated die-cast aluminum
	<b>Option:</b> Stainless steel
Grounding rings	<b>Standard:</b> Stainless steel
	<b>Option:</b> Hastelloy® C, titanium, tantalum
	Other materials on request.
	Grounding rings can be omitted with virtual reference option for the IFC 300 converter.
Mounting materials	<b>Standard:</b> rubber centering sleeves
	<b>Option:</b> stud bolts and nuts in stainless steel or galvanized steel
Gaskets	DN2.5...15 / 1/10...1/2"; O-rings: FKM, EPDM, FFKM DN25...100 / 1...4"; flat gaskets: filled PTFE, Graphite, PTFE / PF-29
	Other materials on request.
Measuring electrodes	DN2.5...25 / 1/10...1": Cermet
	DN40...100 / 1/2...4": Platinum

### Process connections

EN 1092-1	<b>Standard:</b>
	DN100: PN 16
	DN2.5...80: PN 40
	<b>Option:</b>
	DN100: PN 25
ASME	<b>Standard:</b>
	1/10...4": 150 lb
	<b>Option:</b>
	1/10...4": 300 lb
JIS	DN2.5...100: 10...20 K

### Electrical connections

For more details; see the relevant documentation of the signal converter

Signal cable (remote versions only)	
Type A (DS)	<b>In combination with the IFC 100 and IFC 300 signal converter</b> Standard cable, double shielded. Max. length: 600 m / 1950 ft (depends on electrical conductivity and measuring sensor).
Type B (BTS)	<b>Only in combination with the IFC 300 signal converter</b> Optional cable, triple shielded. Max. length: 600 m / 1950 ft (depends on electrical conductivity and measuring sensor).
I/O	For more details of I/O options, including data streams and protocols, see technical datasheet of the relevant signal converter.

## Approvals and certifications

<b>CE</b>	
This device fulfills the statutory requirements of the EU directives. The manufacturer certifies successful testing of the product by applying the CE mark.	
	For full information of the EU directives & standards and the approved certifications, please refer to the EU Declaration of Conformity or the manufacturer website.
<b>Hazardous areas</b>	
Non-Ex	Standard
ATEX	KEMA 04 ATEX 2126 X
	ATEX II 2 GD EEx me ia IIC T6...T3
	ATEX II 2 GD EEx de ia IIC T6...T3
	For more details, see Ex documentation of flow sensor and signal converter.
FM	Class I, Div 2, groups A, B, C and D
	Class II, Div 2, groups F and G
	Class III, Div 2, groups F and G
CSA	Class I, Div 2, groups A, B, C and D
	Class II, Div 2, groups F and G
IECEX	Pending
NEPSI	GYJ05240
	Ex me ia IIC T6...T3 and Ex de ia IIC T6...T3
Protection category acc. to IEC 529 / EN 60529	<b>Standard:</b>
	IP 66/67 (NEMA 4/4X/6)
	<b>Option:</b>
	IP 68 (NEMA 6P)
	IP 68 is only available for remote designs and with a stainless steel connection box.
IP 67/69 with IFC 100 SS (Stainless steel) converter	
Hygiene	FDA approved materials.
Shock test	IEC 68-2-27
	30 g for 18 ms
Vibration test	IEC 68-2-64
	f = 20 - 2000 Hz, rms = 4.5 g, t = 30 min.

## 6.3 Measuring accuracy

Every electromagnetic flowmeter is calibrated by direct volume comparison. The wet calibration validates the performance of the flowmeter under reference conditions against accuracy limits.

The accuracy limits of electromagnetic flowmeters are typically the result of the combined effect of linearity, zero point stability and calibration uncertainty.

### Reference conditions

- Medium: water
- Temperature: +5...35°C / +41...95°F
- Operating pressure: 0.1...5 barg / 1.5...72.5 psig
- Inlet section:  $\geq 5$  DN
- Outlet section:  $\geq 2$  DN

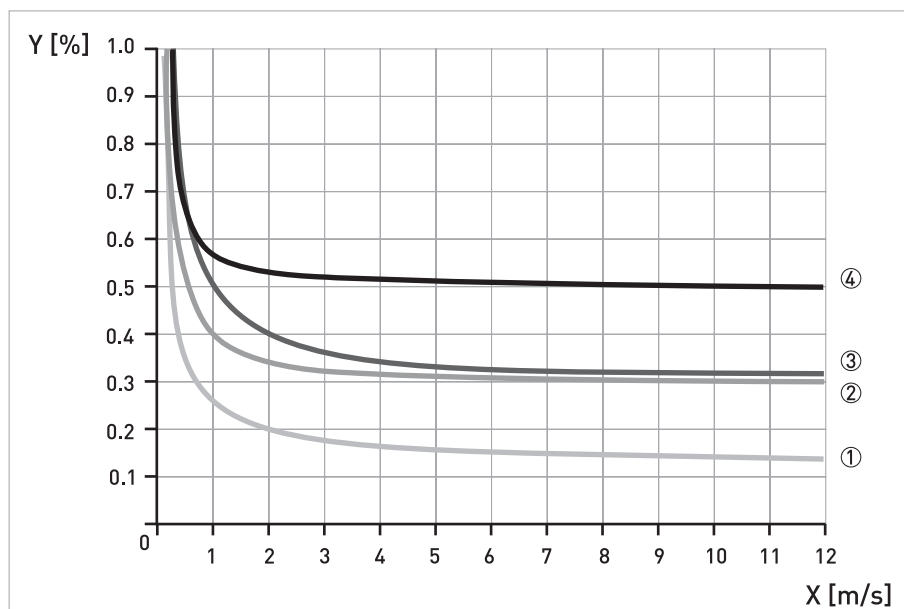

Figure 6-2:  
X [m/s]: flow velocity  
Y [%]: deviation from the actual measured value (mv)

## In combination with the IFC 300

	Accuracy	Curve
DN2.5...6 / 1/10...1/4"	0.3% of mv + 2 mm/s	③
DN10...100 / 3/8... 4"	0.15% of mv + 1 mm/s	①

## In combination with the IFC 100

	Accuracy	Curve
DN2.5...6 / 1/10...1/4"	0.4% of mv + 1 mm/s	As ② + 0.1%
DN10...100 / 3/8...4"	0.3% of mv + 1 mm/s	②

## In combination with the IFC 050

	Accuracy	Curve
DN2.5...6 / 1/10...1/4"	0.5% of mv + 1 mm/s	④
DN10...100 / 3/8...4"	0.5% of mv + 1 mm/s	

**INFORMATION!**

Optionally, extended calibration at 2 points for optimised accuracy available for IFC 050 and IFC 100. See for more details the relevant signal converter documentation

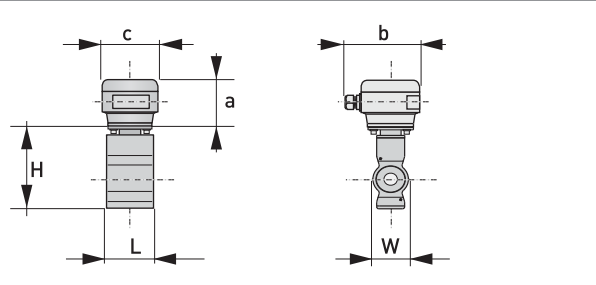
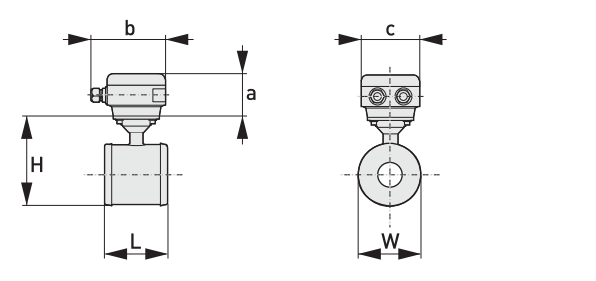
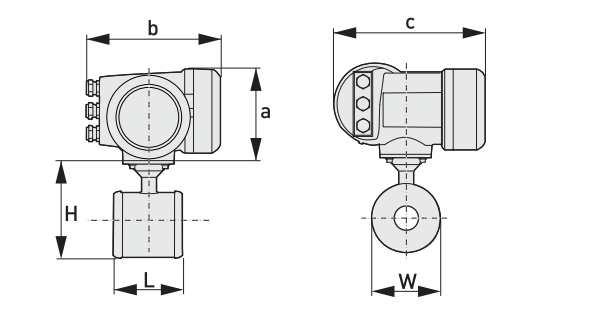
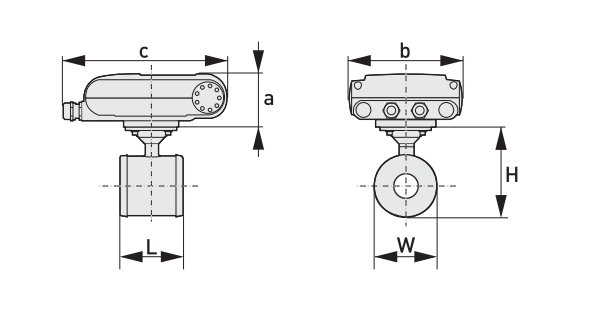
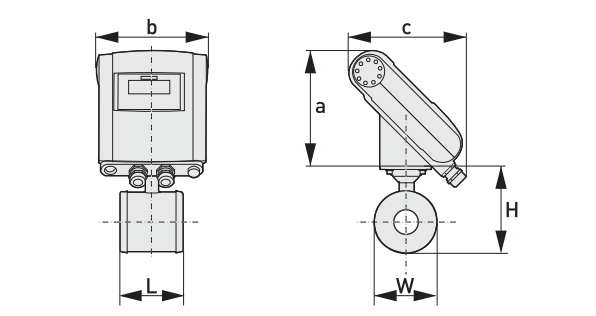

## 6.4 Dimensions and weights

<b>Remote version:</b> DN2.5...15 / 1/10...1/2"		a = 88 mm / 3.5" b = 139 mm / 5.5" ① c = 106 mm / 4.2" Total height = H + a
<b>Remote version:</b> DN25...100 / 1...4"		a = 88 mm / 3.5" b = 139 mm / 5.5" ① c = 106 mm / 4.2" Total height = H + a
<b>Compact version with IFC 300</b>		a = 155 mm / 6.1" b = 230 mm / 9.1" ① c = 260 mm / 10.2" Total height = H + a
<b>Compact version with IFC 100 (0°)</b>		a = 82 mm / 3.2" b = 161 mm / 6.3" c = 257 mm / 10.1" ① Total height = H + a
<b>Compact version with IFC 100 (45°)</b>		a = 186 mm / 7.3" b = 161 mm / 6.3" c = 184 mm / 7.3" ① Total height = H + a

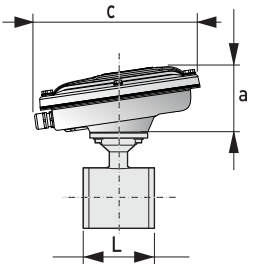
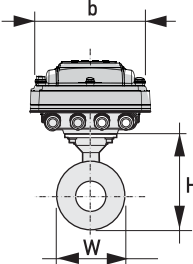
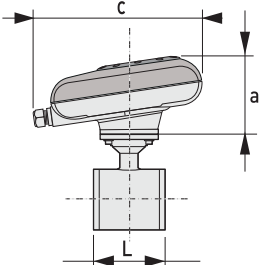
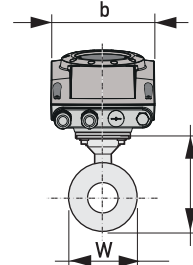
<p><b>Compact version with IFC 100 SS (10°)</b></p>			<p>a = 100 mm / 4"</p> <p>b = 187 mm / 7.36" ①</p> <p>c = 270 mm / 10.63"</p> <p>Total height = H + a</p>
<p><b>Compact version with IFC 050 (10°)</b></p>			<p>a = 100mm / 4"</p> <p>b = 157 mm / 6.18" ①</p> <p>c = 260 mm / 10.24"</p> <p>Total height = H + a</p>

① The value may vary depending on the used cable glands.

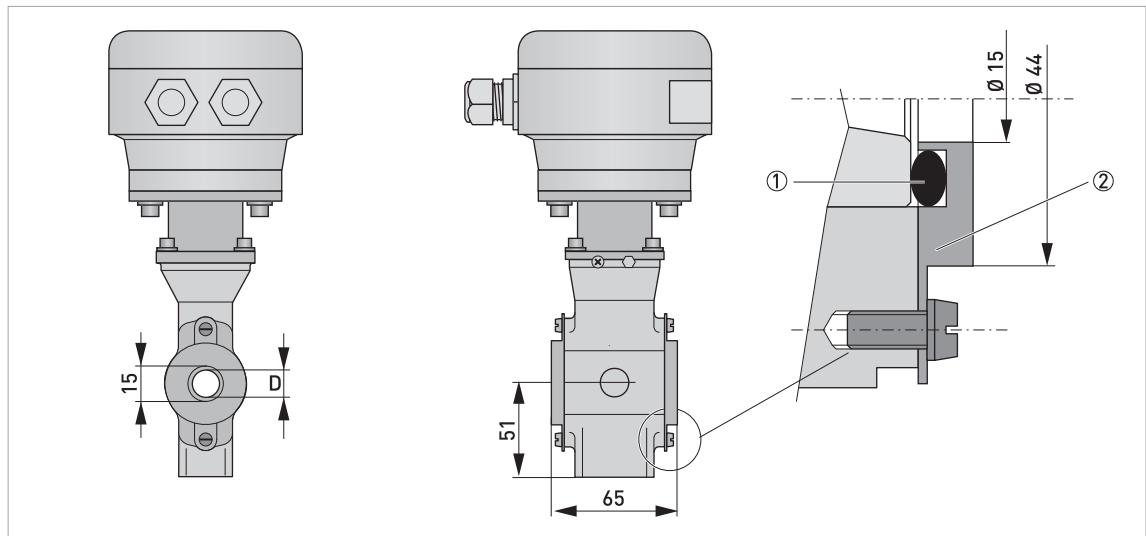

Figure 6-3: Construction details DN2.5...15 / 1/10...1/2"

- ① O-ring
- ② Grounding ring

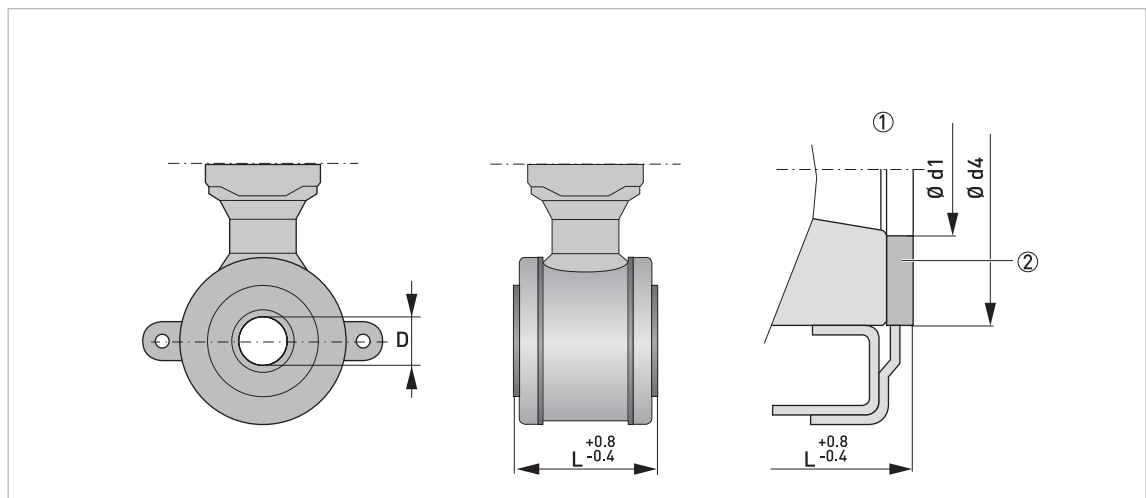

Figure 6-4: Construction details DN25...100 / 1...4"

- ① Situation without grounding rings
- ② Gasket



#### INFORMATION!

- All data given in the following tables are based on standard versions of the flow sensor only.
- Especially for smaller nominal sizes of the flow sensor, the signal converter can be bigger than the flow sensor.
- Note that for other pressure ratings than mentioned, the dimensions may be different.
- For full information on signal converter dimensions see relevant documentation.

Nominal size	Dimensions [mm]						Approx. weight [kg]	
	DN	L	H	W	D	Ød1		Ød4
2.5	65 ①	123	44			-	-	1.6
4	65 ①	123	44			-	-	1.6
6	65 ①	123	44			-	-	1.6
10	65 ①	123	44			-	-	1.6
15	65 ①	123	44			-	-	1.6
25	58 ②	116	68	20	26	46		1.6
40	83 ②	131	83	30	39	62		2.4
50	103 ②	149	101	40	51	74		2.9
80	153 ②	181	133	60	80	106		6.4
100	203 ②	206	158	80	101	133		8.8

① Total fitting length of flowmeter with integrated rings: dimension L + 2 x gasket thickness.

② Total fitting length of flowmeter without rings: dimension L only.

Nominal size	Dimensions [inches]						Approx. weight [lb]	
	ASME	L	H	W	D	Ød1		Ød4
1/10"	2.56 ①	4.84	1.73			-	-	3.53
1/8"	2.56 ①	4.84	1.73			-	-	3.53
¼"	2.56 ①	4.84	1.73			-	-	3.53
3/8"	2.56 ①	4.84	1.73			-	-	3.53
½"	2.56 ①	4.84	1.73			-	-	3.53
1"	2.28 ②	4.57	2.68	0.79	1.02	1.81		3.53
1½"	3.27 ②	5.16	3.27	1.18	1.54	2.44		5.29
2"	4.06 ②	5.87	3.98	1.57	2.01	2.91		6.39
3"	6.02 ②	7.13	5.24	2.36	3.15	4.17		14.11
4"	7.99 ②	8.11	6.22	3.15	3.98	5.24		19.40

① Total fitting length of flowmeter with integrated rings: dimension L + 2 x gasket thickness.

② Total fitting length of flowmeter without rings: dimension L only.









## KROHNE – Process instrumentation and measurement solutions

- Flow
- Level
- Temperature
- Pressure
- Process Analysis
- Services

Head Office KROHNE Messtechnik GmbH  
Ludwig-Krohne-Str. 5  
47058 Duisburg (Germany)  
Tel.: +49 203 301 0  
Fax: +49 203 301 10389  
info@krohne.com

The current list of all KROHNE contacts and addresses can be found at:  
[www.krohne.com](http://www.krohne.com)

**KROHNE**