

# Signet 8058 i-Go™ Signal Converter

English

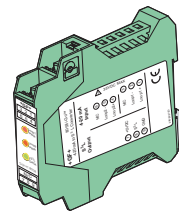

3-8058.090 Rev. D 06/12 English



## Description

The 8058 Signal Converter accepts any 4 to 20 milliamp (mA) signal and converts it into the serial data format known as S<sup>3</sup>L (Signet Serial Sensor Link) for use by the Signet 8250, 8350, 8450, and Multi-Parameter and SmartPro instruments.

- When used with the Multi-Parameter and SmartPro instruments, all programming uses the instrument's familiar setup menus.
- When used with ProcessPro transmitters, the 8058 is configured at the factory to the user's specifications.
- The 8058-1 wire-mount version is easily mounted anywhere in the interconnecting wiring between a single 4 to 20 mA source and the instrument.
- The 8058-2 DIN-rail mounted version converts two separate 4 to 20 mA source signals into the S<sup>3</sup>L format.

## Specifications

### General

Input:	4 to 20 mA current loop(s), passive (external power required)
Input range:	3.6 to 22.1 mA
Output:	Digital (S <sup>3</sup> L) output
3-8058-2:	calibrated mA
Accuracy:	± 32 µA @ 25 °C
Resolution:	< 16 µA
Update rate:	500 mS
Temp. Drift:	±1 µA per °C, max.

### Electrical

Power req.:	4.5 to 6.5 VDC @ < 3.0 mA
Max. voltage:	35 VDC
Max. current:	40 mA
Isolation:	Up to 48 V AC/DC
Voltage drop:	5 VDC max.
Reverse polarity protected	

### Cable:

3-8058-1:	400 mm (15 in.) input, 200 mm (8 in.) output
3-8058-2:	No cable provided (customer supplied)
Max. recommended cable extensions:	
• Loop in:	300 m (1000 ft)
• S <sup>3</sup> L out:	per S <sup>3</sup> L guidelines

### Environmental

Operating Ambient Temperature:	-10 to 55 °C (14 to 131 °F)
Storage Temperature:	-20 to 85 °C (-4 to 185 °F)
Relative Humidity:	
3-8058-1:	0 to 100%, condensing
3-8058-2:	0 to 90%, non-condensing
Shipping Weight:	
3-8058-1:	0.09 kg (0.20 lb)
3-8058-2:	0.11 kg (0.25 lb)

## Standards and Approvals

CE

China RoHS (Go to [gfsignet.com](http://gfsignet.com) for details)

## Dimensions

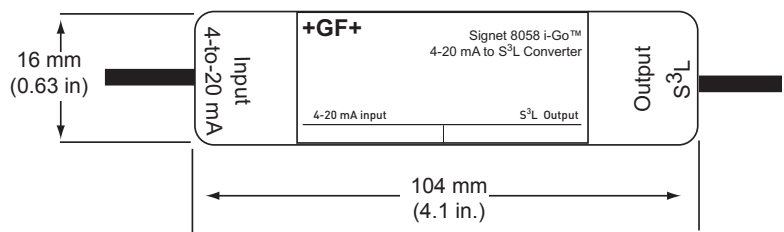

3-8058-1 Signal Converter, wire-mount

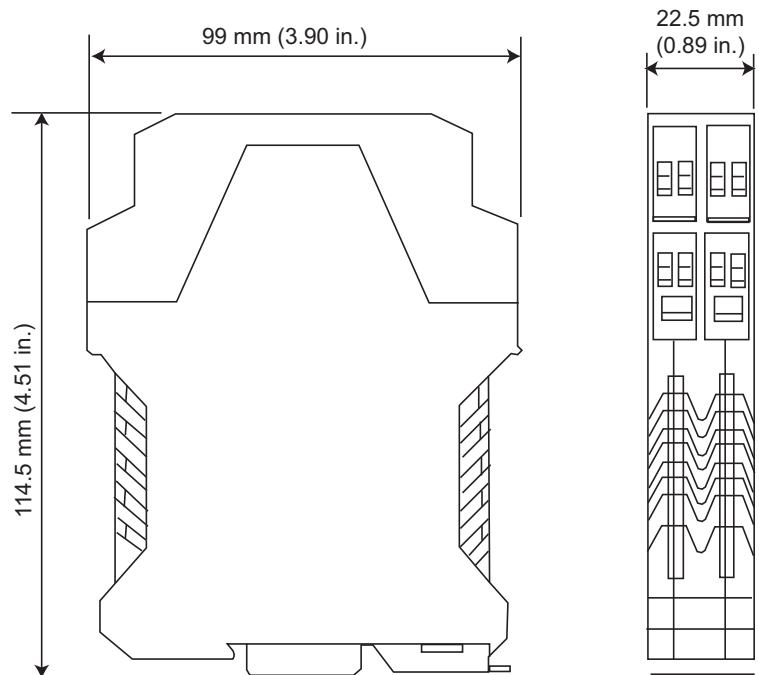

3-8058-2 Signal Converter, DIN-rail mount

# Wiring

## Wiring Tips:

- Do not route sensor cable in conduit containing AC power wiring. Electrical noise may interfere with the signal.
- Routing cable in grounded metal conduit will help prevent electrical noise and mechanical damage.
- Seal cable splices tightly to prevent moisture damage.
- The cable length from the 8058 to the 8900/9900 must not exceed the S<sup>3</sup>L limitations as defined in the instruction manuals.

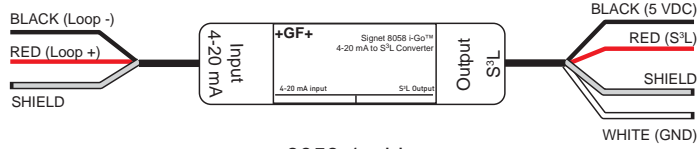

8058-1 wiring

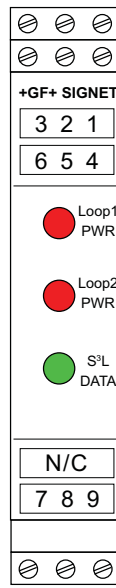

8058-2 interface

Two 4 to 20 mA loop signals can be connected to the 8058-2.

The red Loop LEDs indicate when one or both of the 4 to 20 mA loop inputs are powered.

The green DATA LED indicates when the data output is active.

The S<sup>3</sup>L output terminals carry the input loop signals.

## 8058-1 Wire Mount to Signet 8900 Multi-Parameter Controller

1. Wire the 8058-1 between the 4 to 20 mA loop source and the 8900 S<sup>3</sup>L input terminals as illustrated.
2. In the 8900 menu, assign a channel for this input, and specify the input parameter.  
If the 4 to 20 mA SOURCE is one of the standard 8900 input parameters (Flow, pH, Conductivity, etc.) select that channel type. If the 4 to 20 mA SOURCE is not included in the 8900 menu, select OTHER (4-20) and then set additional labels and abbreviations per the 8900 instructions.
3. Follow complete instructions in the 8900 manual to set up the new channel.

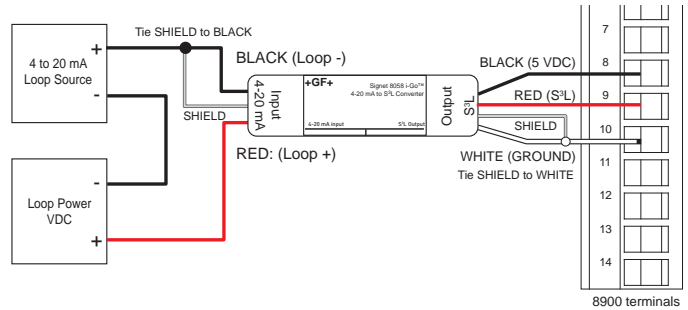

**CAUTION**  
Loop power must not exceed 35 VDC.

## 8058-2 DIN Rail Mount to Signet 8900 Multi-Parameter Controller

1. Wire the 8058-2 between the 4 to 20 mA loop source and the 8900 S<sup>3</sup>L input terminals as illustrated.
2. In the 8900 menu, assign a channel for this input, and specify the input parameter.  
If the 4 to 20 mA SOURCE is one of the standard 8900 input parameters (Flow, pH, Conductivity, etc.) select that channel type. If the 4 to 20 mA SOURCE is not included in the 8900 menu, select OTHER (4-20) and then set additional labels and abbreviations per the 8900 instructions.
3. Follow complete instructions in the 8900 manual to set up the new channel.

**CAUTION**  
Loop power must not exceed 35 VDC.

The 8058-2 accepts two 4 to 20 mA loop input signals and converts them into two S<sup>3</sup>L serial data signals for input to the Signet 8900, where each loop is completely independent. The 8058 transmits information to identify the two signals by using the serial number of the 8058 converter:

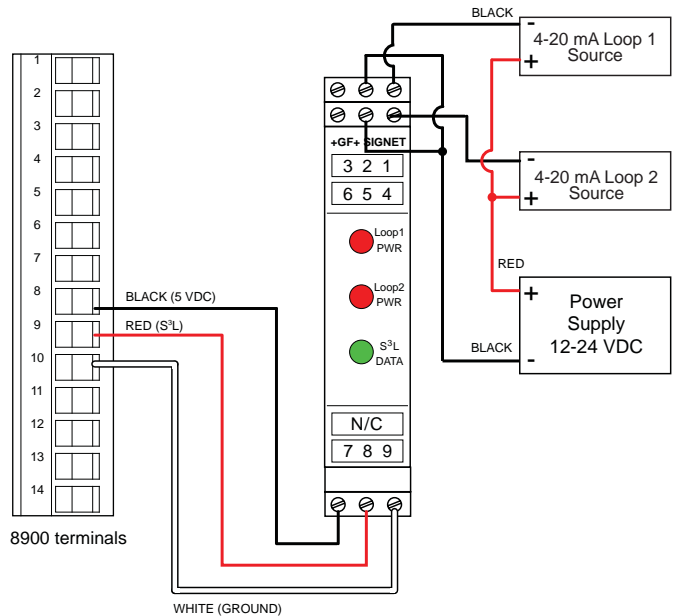

- The manufacture date of the 8058 is included in the serial number label on the instrument.
- The 8058 converter transmits the serial number onto the S<sup>3</sup>L bus as the ID for the Loop 1.
- The 8058 transmits a second serial number for Loop 2 by adding 12 to the month. (6040630.... becomes 6041830....)

**Loop 1:** ~~X~~ **04 06 30 1234**  
Disregard Year Month Day Sequential  
mfg mfg mfg

**Loop 2:** ~~X~~ **04 18 30 1234**

## 8058-1 Wire Mount to Signet 9900 Transmitter

1. Wire the 8058-1 between the 4 to 20 mA loop source and the 9900 S<sup>3</sup>L input terminals as illustrated.
2. In the 9900 INPUT TYPE menu, specify 4-20 mA INPUT.  
Set additional labels and abbreviations per the 9900 instructions.
3. Follow complete instructions in the 9900 manual.

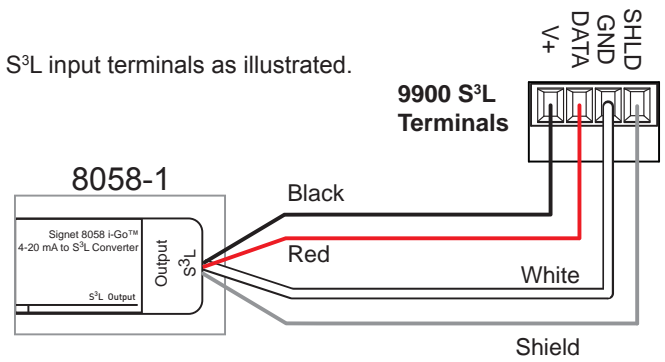
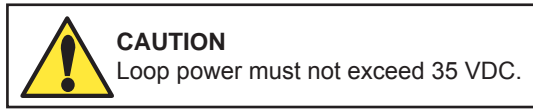

## 8058-2 DIN Rail Mount to Signet 9900 Transmitter

1. Wire ONLY Channel 1, terminals 1 and 2, of the 8058-2 between the 4 to 20 mA loop source and the 9900 S<sup>3</sup>L input terminals as illustrated.
2. In the 9900 INPUT TYPE menu, specify 4-20 mA INPUT.  
Set additional labels and abbreviations per the 9900 instructions.
3. Follow complete instructions in the 9900 manual.

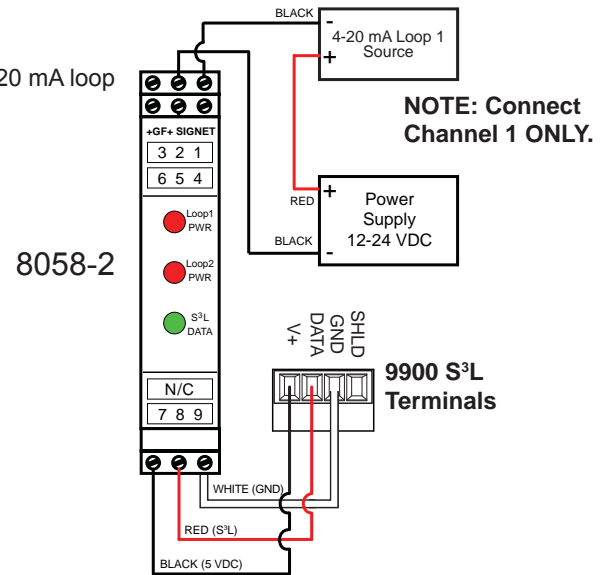
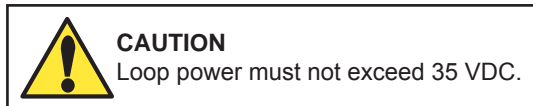

## Wiring: 8058-1 Wire Mount to Signet 8250, 8350 and 8450 ProcessPro Transmitters

When used in conjunction with the Signet ProcessPro Pressure, Temperature or Level Transmitters, the 8058 serves to expand the operating range beyond the specifications of sensors available directly from Signet.

1. Order the 8058 according to the instructions on page 4. The 8058 MUST be factory configured for these applications.
2. Connect the 8058 between the 4 to 20 mA loop source and the ProcessPro S<sup>3</sup>L input terminals as illustrated.
3. Follow the complete CALIBRATION instructions in the ProcessPro manual.

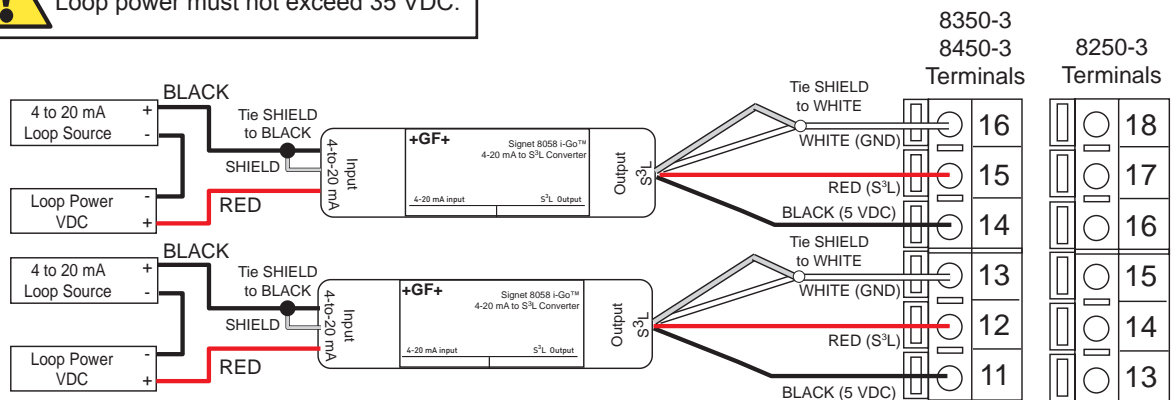
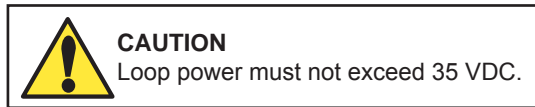
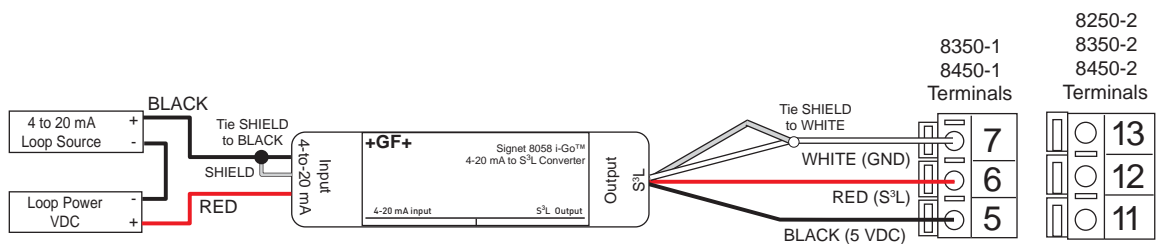

## Wiring: 8058-2 DIN Rail Mount to Signet 8250, 8350, and 8450 ProcessPro Transmitters

When using the 8058-2 with the Signet 8250-3, 8350-3 or 8450-3, both loop sources must be of the same TYPE, and the 8058-2 MUST be factory configured to the correct range.

1. Order the 8058-2 according to the instructions below. The 8058 MUST be factory configured for these applications.
2. Connect the 8058 between the 4 to 20 mA loop source and the ProcessPro S<sup>3</sup>L input terminals as illustrated.
3. Follow the complete CALIBRATION instructions in the ProcessPro manual.

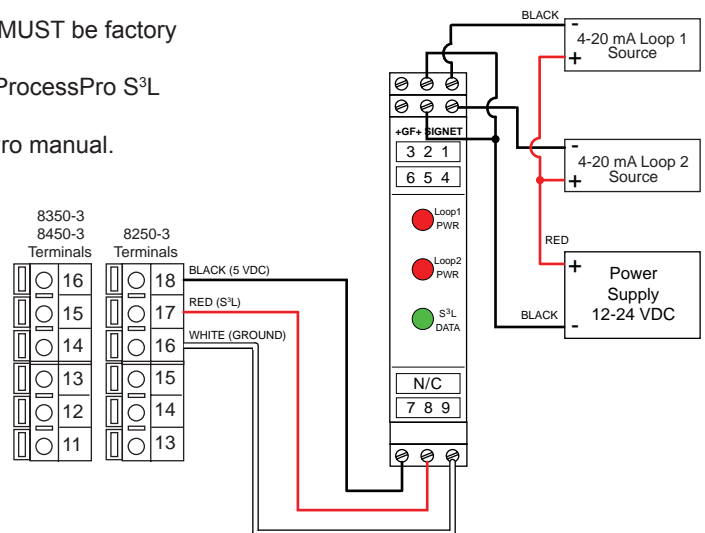
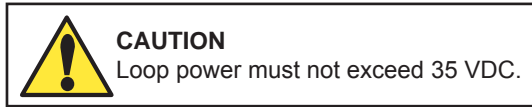

### IMPORTANT! SPECIAL INFORMATION for ProcessPro Users:

The following information is REQUIRED with all converters that will be connected to:

- Signet 8250 Level Transmitter
- Signet 8350 Temperature Transmitter
- Signet 8450 Pressure Transmitter

#### 1. Select the 8058 model preferred:

- \_\_\_\_\_ 3-8058-1S Wire-mount current to S<sup>3</sup>L converter (for use with 8250, 8350 or 8450-1 or -2 model Transmitters)
- \_\_\_\_\_ 3-8058-2S DIN rail mount current to S<sup>3</sup>L converter, dual input (for use with 8250-3, 8350-3 or 8450-3 Transmitters)

#### 2. Specify the Signet ProcessPro model to be connected to the 8058:

- \_\_\_\_\_ 8250 Level Transmitter      \_\_\_\_\_ 8350 Temperature Transmitter      \_\_\_\_\_ 8450 Pressure Transmitter

#### 3. Specify the operating range and engineering units from the input 4-20 mA loop source:

- Loop 1:                      4 mA = \_\_\_\_\_ (specify units)                      20 mA = \_\_\_\_\_ (specify units)
- Loop 2 (-3 models only): 4 mA = \_\_\_\_\_ (specify units)                      20 mA = \_\_\_\_\_ (specify units)

Note: For dual-loop systems, both input loops must be the same parameter, but the ranges may be different.

#### 4. Contact a Signet representative

Due to the customization requirements, the 8058 Converter requires special handling when intended for use with ProcessPro transmitters. Consult with Signet product specialist for these requirements.

### Ordering Information

Mfr. Part No.	Code	Description
3-8058-1	159 000 966	Wire-mount current to S <sup>3</sup> L converter for use with Signet 8900 or 9900
3-8058-2	159 000 967	DIN rail mount current to S <sup>3</sup> L converter, dual input for use with Signet 8900 or 9900

**NOTE:** If the 8058 converter is to be used with any 8250, 8350 or 8450 ProcessPro Transmitter, add S to the order number, complete the information noted above, and contact your Signet representative.



Georg Fischer Signet LLC, 3401 Aerojet Avenue, El Monte, CA 91731-2882 U.S.A. • Tel. (626) 571-2770 • Fax (626) 573-2057  
 For Worldwide Sales and Service, visit our website: [www.gfsignet.com](http://www.gfsignet.com) • Or call (in the U.S.): (800) 854-4090  
 For the most up-to-date information, please refer to our website at [www.gfsignet.com](http://www.gfsignet.com)