

# Flexim FLUXUS F532WD Ultrasonic Flowmeter



## Permanently Installed Clamp-on Measuring System for Water and Wastewater Pipes

### Features

- Highly accurate non-invasive flow and temperature measurement irrespective of the flow direction (bidirectional), with outstanding measurement dynamics, excellent zero-point stability and high repeatability of the measurement results
- Submersible ultrasonic transducers (IP68) provide a reliable and durable solution for flow measurement on buried pipes or for applications where the measuring point can be overflowed
- Simple retrofitting on existing water networks without interruption of supply and disposal and without the need for shaft construction and pipe intrusion, thus saving time and cost

### Applications

- Flow and temperature measurement on buried water and wastewater pipes
- Flow and temperature measurement on water and wastewater pipes which can be overflowed

**Function** ..... 3

Measurement principle ..... 3

Calculation of volumetric flow rate ..... 3

Calculation of sound speed and fluid temperature ..... 4

Number of sound paths ..... 4

**Transmitter** ..... 5

Technical data ..... 5

Dimensions ..... 7

2" pipe mounting kit (optional) ..... 7

Storage ..... 7

Terminal assignment ..... 8

**Transducers** ..... 9

Transducer selection ..... 9

Technical data ..... 9

Transducer mounting fixture ..... 11

Coupling materials for transducers ..... 11

Connection systems ..... 12

**Junction box** ..... 13

Technical data ..... 13

Dimensions ..... 13

2" pipe mounting kit ..... 14

## Function

### Measurement principle

The transducers are mounted on the pipe which is completely filled with the fluid. The ultrasonic signals are emitted alternately by a transducer and received by the other. The physical quantities are determined from the transit times of the ultrasonic signals.

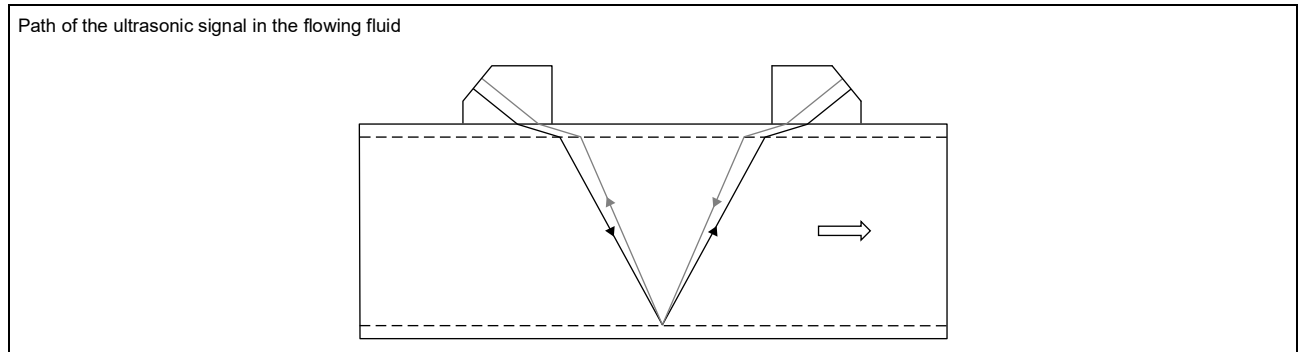

### Transit time difference principle

As the fluid where the ultrasound propagates is flowing, the transit time of the ultrasonic signal in flow direction is shorter than the one against the flow direction.

The transit time difference  $\Delta t$  is measured and allows the flowmeter to determine the average flow velocity along the propagation path of the ultrasonic signals. A flow profile correction is then performed in order to obtain the area averaged flow velocity, which is proportional to the volumetric flow rate.

The integrated microprocessors control the entire measuring cycle. The received ultrasonic signals are checked for measurement usability and evaluated for their reliability. Noise signals are eliminated.

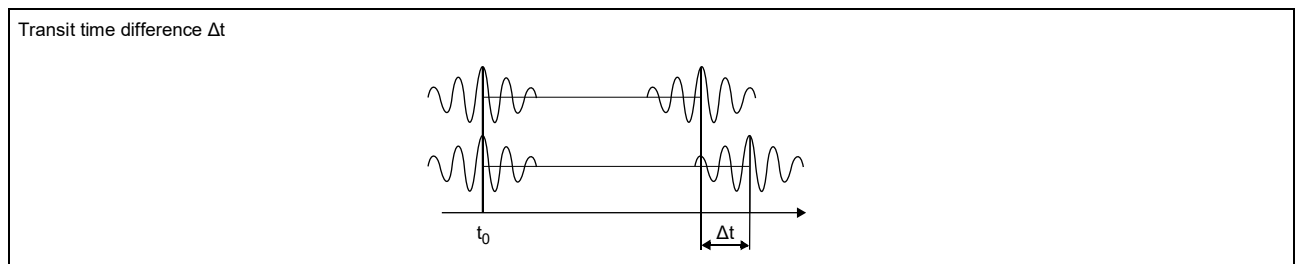

### HybridTrek

If the gaseous or solid content in the fluid increases occasionally during measurement, a measurement with the transit time difference principle may no longer be possible. NoiseTrek mode will then be selected by the flowmeter. This measurement method allows the flowmeter to achieve a stable measurement even with high gaseous or solid content.

The transmitter automatically toggles between the TransitTime and the NoiseTrek mode without having to change the measuring setup.

### Calculation of volumetric flow rate

$$\dot{V} = k_{Re} \cdot A \cdot k_a \cdot \frac{\Delta t}{2 \cdot t_y}$$

where

- $\dot{V}$  - volumetric flow rate
- $k_{Re}$  - fluid mechanic calibration factor
- $A$  - cross-sectional pipe area
- $k_a$  - acoustic calibration factor
- $\Delta t$  - transit time difference
- $t_y$  - average of transit times in the fluid

### Calculation of sound speed and fluid temperature

The fluid sound speed can be determined from the transit times in the fluid and the geometry of the measuring point. The sound speed is fluid specific and temperature dependent. This curve is stored in the fluid data set for water. Thus, the fluid temperature can be determined from the sound speed.

### Number of sound paths

The number of sound paths is the number of transits of the ultrasonic signal through the fluid in the pipe. Depending on the number of sound paths, the following methods of installation exist:

- **reflect arrangement**  
The number of sound paths is even. The transducers are mounted on the same side of the pipe. Correct positioning of the transducers is easy.
- **diagonal arrangement**  
The number of sound paths is odd. The transducers are mounted on opposite sides of the pipe.
- **direct mode**  
Diagonal arrangement with 1 sound path. This should be used in the case of a high signal attenuation by the fluid, pipe or coatings.

The preferred method of installation depends on the application. While increasing the number of sound paths increases the accuracy of the measurement, signal attenuation increases as well. The optimum number of sound paths for the parameters of the application will be determined automatically by the transmitter.

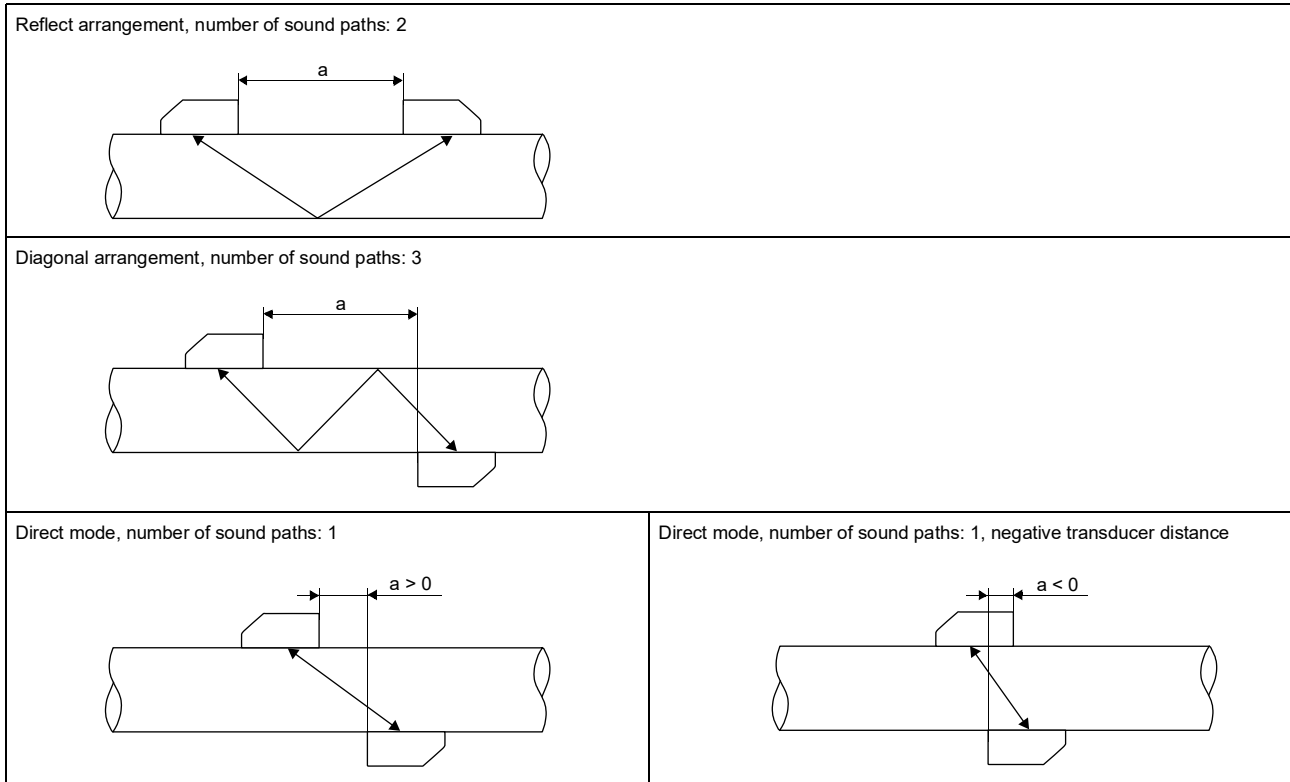

As the transducers can be mounted with the transducer mounting fixture in reflect arrangement or diagonal arrangement, the number of sound paths can be adjusted optimally for the application.



a - transducer distance

# Transmitter

## Technical data

		FLUXUS F532WD (analog outputs)	FLUXUS F532WD (process interface)
			
design		field device with 1 measuring channel	
application		flow measurement at water pipes	
<b>measurement</b>			
measurement principle		transit time difference correlation principle, automatic NoiseTrek selection for measurements with high gaseous or solid content	
flow direction		bidirectional	
flow velocity	ft/s	0.03 to 82	
repeatability		0.15 % MV ±0.02 ft/s	
fluid		water	
temperature compensation		corresponding to the recommendations in ANSI/ASME MFC-5.1-2011	
<b>measurement uncertainty (volumetric flow rate)</b>			
measurement uncertainty of the measuring system <sup>1</sup>		±0.3 % MV ±0.02 ft/s includes calibration certificate traceable to NIST	
measurement uncertainty at the measuring point <sup>2</sup>		±1 % MV ±0.02 ft/s	
<b>measurement uncertainty (temperature from sound speed)</b>			
measurement uncertainty at the measuring point <sup>2</sup>		±0.2 K (fluid temperature: 32 to 86 °F, inner pipe diameter: min. 7.9 inch)	
<b>transmitter</b>			
power supply		<ul style="list-style-type: none"> <li>• 90 to 250 V/50 to 60 Hz or</li> <li>• 11 to 32 V DC</li> </ul>	
power consumption	W	< 10	
number of measuring channels		1	
damping	s	0 to 100 (adjustable)	
measuring cycle	Hz	100 to 1000	
response time	s	1	
housing material		aluminum, powder coated	
degree of protection		IP66	
dimensions	inch	see dimensional drawing	
weight	lb	7	
fixation		wall mounting, optional: 2" pipe mounting	
ambient temperature	°F	-4 to +140	
display		128 x 64 pixels, backlight	
menu language		English, German, French, Spanish, Dutch, Russian, Polish, Turkish, Italian, Chinese	
<b>certificates</b>			
use in unclassified (ordinary) locations		optional:  FM23NUS0010 FM23NCA0007	
<b>measuring functions</b>			
physical quantities		volumetric flow rate, mass flow rate, flow velocity	
totalizer		volume, mass	
diagnostic functions		sound speed, signal amplitude, SNR, SCNR, standard deviation of amplitudes and transit times	
<b>communication interfaces</b>			
service interfaces		measured value transmission, parametrization of the transmitter: <ul style="list-style-type: none"> <li>• USB</li> <li>• LAN</li> </ul>	measured value transmission, parametrization of the transmitter: <ul style="list-style-type: none"> <li>• USB</li> <li>• LAN</li> </ul>
process interfaces		-	1 option: <ul style="list-style-type: none"> <li>• Modbus RTU</li> <li>• BACnet MS/TP</li> <li>• HART</li> <li>• Modbus TCP</li> <li>• BACnet IP</li> </ul>
<b>accessories</b>			
data transmission kit		USB cable	
software		<ul style="list-style-type: none"> <li>• FluxDiagReader: reading of measured values and parameters, graphical representation</li> <li>• FluxDiag (optional): reading of measurement data, graphical representation, report generation, parametrization of the transmitter</li> </ul>	

<sup>1</sup> with aperture calibration of the transducers

<sup>2</sup> for transit time difference principle and reference conditions

	FLUXUS F532WD (analog outputs)	FLUXUS F532WD (process interface)
<b>data logger</b>		
loggable values	all physical quantities and totalized physical quantities	
capacity	max. 800 000 measured values	
<b>outputs</b>		
	The outputs are galvanically isolated from the transmitter.	
<b>• switchable current output</b>		
	configurable according to NAMUR NE 43 All switchable current outputs are jointly switched to active or passive.	
number	1, optional: 2	optional: 1 (HART)
range	mA 4 to 20 (alarm current: 3.2 to 3.99, 20.01 to 24, hardware fault current: 3.2)	4 to 20 (alarm current: 3.2 to 3.99, 20.01 to 24, hardware fault current: 3.2)
uncertainty	0.04 % of output value ±3 µA	
active output	$R_{ext} = 250 \text{ to } 530 \Omega$ , $U_{opencircuit} = 28 \text{ V DC}$	
passive output	$U_{ext} = 9 \text{ to } 30 \text{ V DC}$ , depending on $R_{ext}$ ( $R_{ext} < 458 \Omega$ at 20 V)	
current output in HART mode		
• range	mA -	4 to 20 (alarm current: 3.5 to 3.99, 20.01 to 22, hardware fault current: 3.2)
• active output	-	$R_{ext} = 250 \text{ to } 530 \Omega$ , $U_{opencircuit} = 28 \text{ V DC}$
• passive output	-	$U_{ext} = 9 \text{ to } 30 \text{ V DC}$ , depending on $R_{ext}$ ( $R_{ext} = 250 \text{ to } 458 \Omega$ at 20 V)
<b>• digital output</b>		
number	2, optional: 4	-
functions	<ul style="list-style-type: none"> <li>• frequency output</li> <li>• binary output</li> <li>• pulse output</li> </ul>	-
type	open collector (passive)	-
operating parameters	5 to 30 V, $I_{max} = 100 \text{ mA}$ , $R_{int} = 20 \Omega$ Low: $U < 2 \text{ V}$ at $I_{loop} = 2 \text{ mA}$ ( $R_{ext} = 12 \text{ k}\Omega$ at $U_{ext} = 24 \text{ V}$ ) High: $U > 15 \text{ V}$ ( $R_{ext} = 12 \text{ k}\Omega$ at $U_{ext} = 24 \text{ V}$ )	-
<b>frequency output</b>		
• range	kHz 0.002 to 10	-
• damping	s 0 to 999.9 (adjustable)	-
• pulse-to-pause ratio	1:1	-
<b>binary output</b>		
• binary output as alarm output	limit, change of flow direction or error	-
<b>pulse output</b>		
• pulse value	units 0.01 to 1000	-
• pulse width	ms 0.05 to 1000	-
• pulse rate	max. 10 000 pulses	-

<sup>1</sup> with aperture calibration of the transducers

<sup>2</sup> for transit time difference principle and reference conditions

**Dimensions**

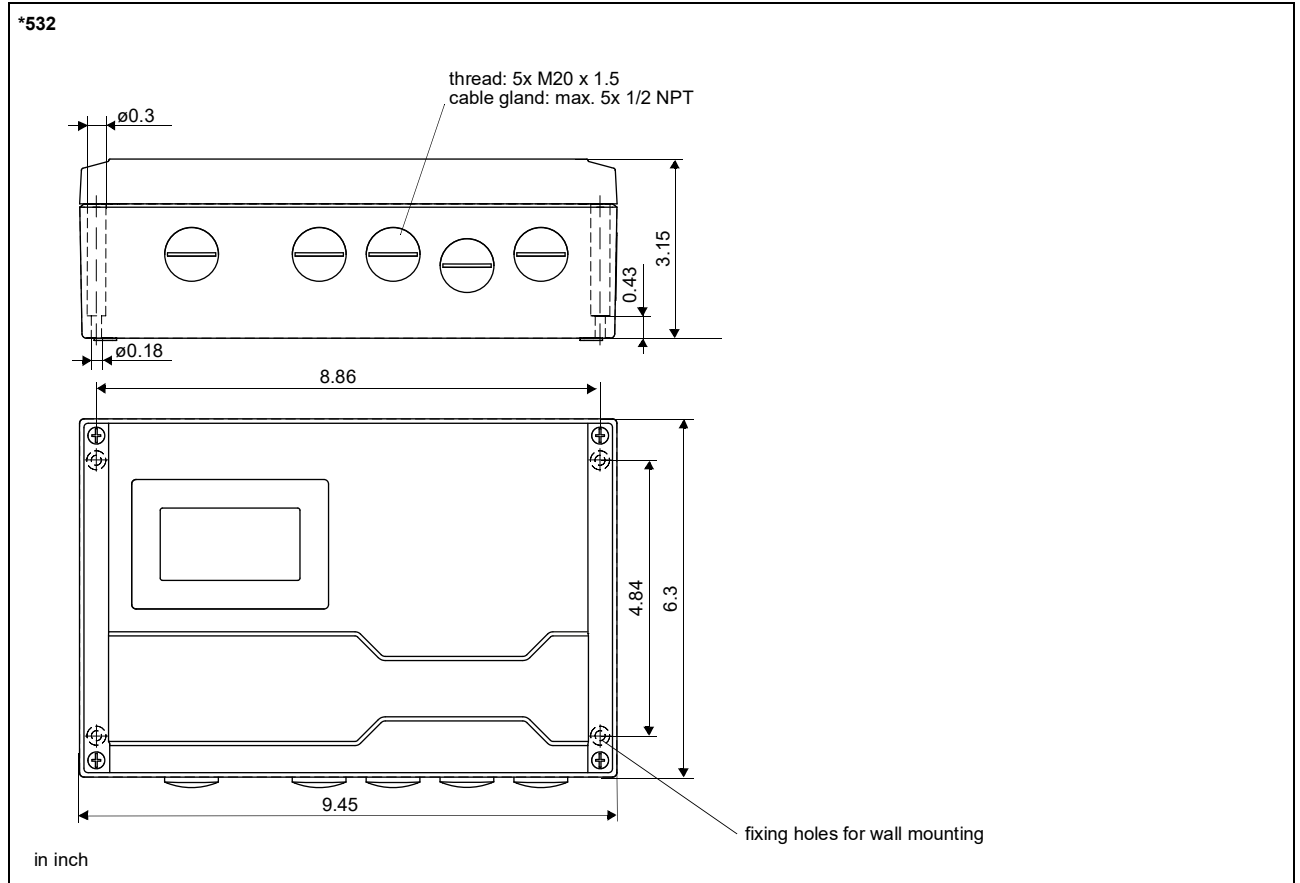

**2" pipe mounting kit (optional)**

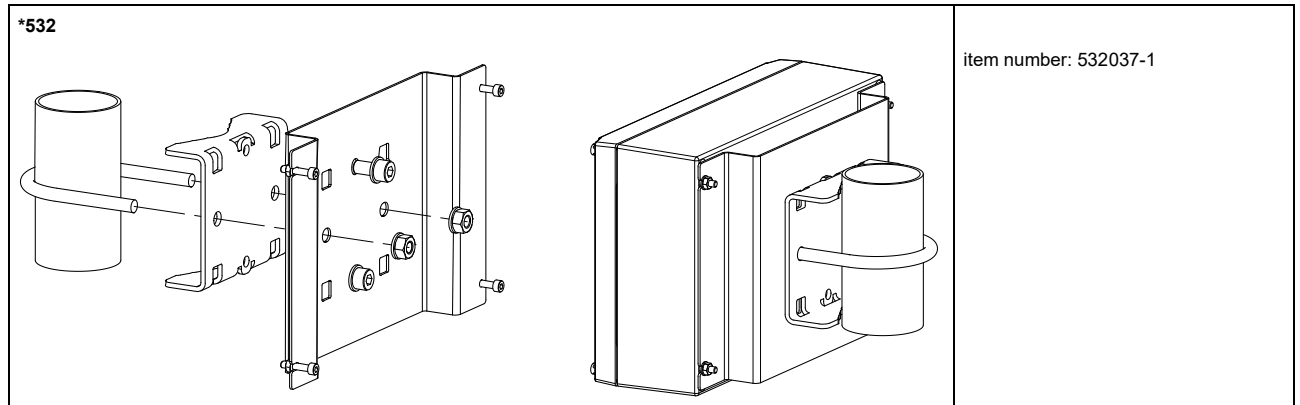

**Storage**

- do not store outdoors
- store within the original package
- store in a dry and dust-free place
- protect against sunlight
- keep all openings closed
- storing temperature: -4...+140 °F

## Terminal assignment

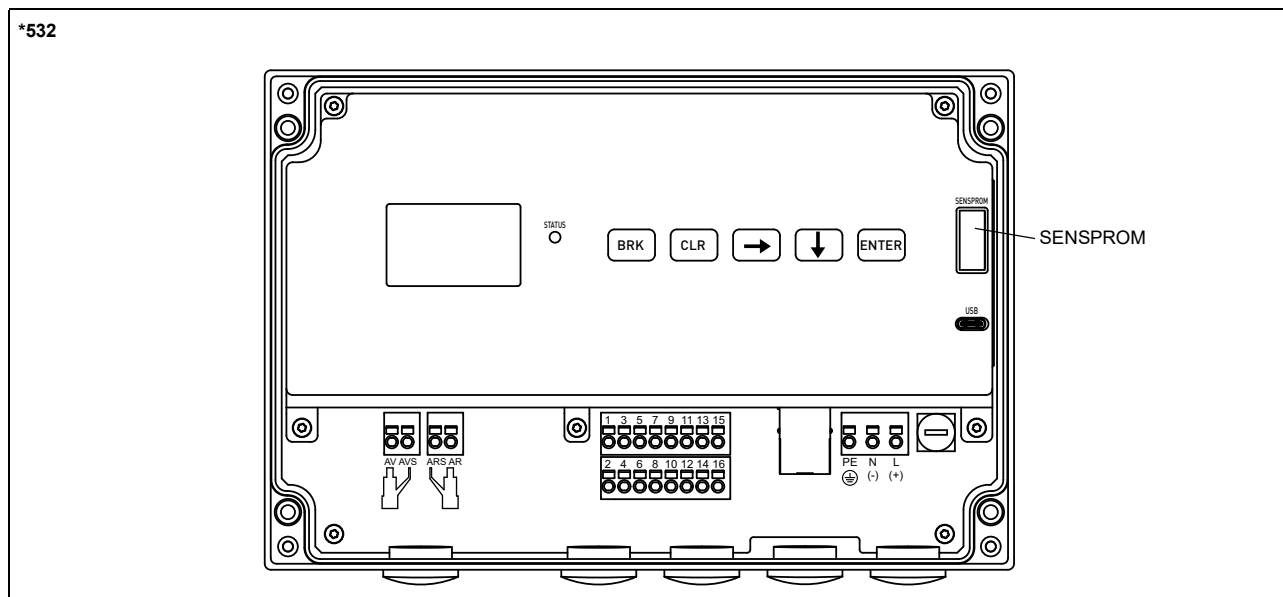

power supply <sup>1</sup>			
terminal	connection (AC)	terminal	connection (DC)
PE	protective conductor	PE	protective conductor
N	neutral conductor	(-)	-
L	line conductor	(+)	+

transducers, extension cable			
terminal	connection	transducer	
AV	signal	↑	
AVS	internal shield		
ARS	internal shield	⌋	
AR	signal		
cable gland	external shield	↑ ⌋	

outputs <sup>1, 2</sup>	
terminal	connection
5+, 6- 13+, 14-	passive current output
5-, 6+ 13-, 14+	active current output
1+, 2- 3+, 4- 9+, 10- 11+, 12-	digital output
15+, 16-	passive current output/HART
15-, 16+	active current output/HART

communication interfaces		
terminal	connection	communication interface
15	signal +	<ul style="list-style-type: none"> <li>• Modbus RTU<sup>1</sup></li> <li>• BACnet MS/TP<sup>1</sup></li> </ul>
16	signal -	
USB	type C Hi-Speed USB 2.0 Device	service (FluxDiag/FluxDiagReader)
LAN	RJ45 10/100 Mbps Ethernet	<ul style="list-style-type: none"> <li>• service (FluxDiag/FluxDiagReader)</li> <li>• Modbus TCP</li> <li>• BACnet IP</li> </ul>

<sup>1</sup> cable (by customer): e.g., flexible wires, with insulated wire ferrules, wire cross-section: AWG14 to 24

<sup>2</sup> The number, type and terminal assignment are customized.

# Transducers

## Transducer selection

transducer order code

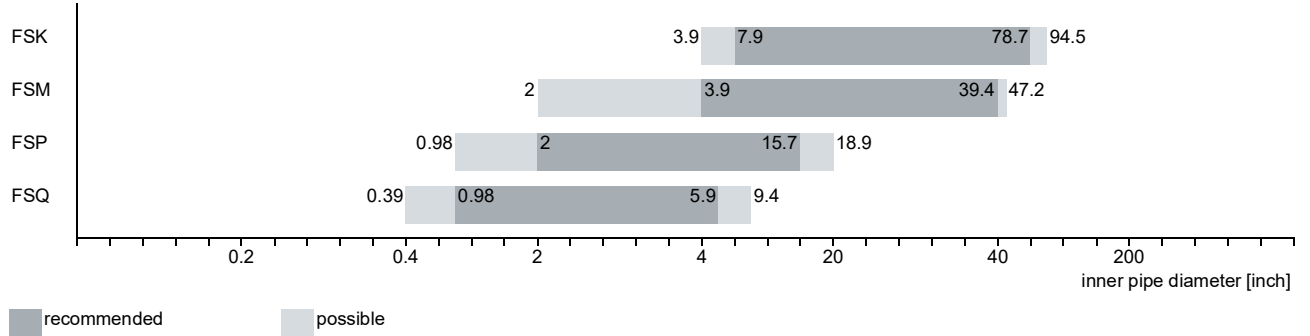

## Technical data

### Shear wave transducers

order code		FSK-N***T1	FSM-N***T1	FSP-N***T1	FSQ-N***T1
technical type		C(DL)K1N53	C(DL)M2N53	C(DL)P2N53	C(DL)Q2N53
transducer frequency	MHz	0.5	1	2	4
<b>inner pipe diameter d</b>					
min. extended	inch	3.9	2	0.98	0.39
min. recommended	inch	7.9	3.9	2	0.98
max. recommended	inch	78.7	39.4	15.7	5.9
max. extended	inch	94.5	47.2	18.9	9.4
<b>pipe wall thickness</b>					
min.	inch	0.2	0.1	0.05	0.02
<b>material</b>					
housing		PEEK with stainless steel cover 316L			
contact surface		PEEK			
degree of protection		IP66	IP66/IP67		
<b>transducer cable</b>					
type		1699			
length	ft	16	13	9	
<b>dimensions</b>					
length l	inch	4.98	2.52	1.57	
width b	inch	2.01	1.26	0.87	
height h	inch	2.66	1.59	1	
dimensional drawing					
weight (without cable)	lb	0.79	0.15	0.04	
pipe surface temperature	°F	-40 to +266			
ambient temperature	°F	-40 to +266			
temperature compensation		x			

**Shear wave transducers (IP68)**

order code		FSK-LNNN-**T1 -***/H68	FSM-LNNN-**T1 -***/H68	FSP-LNNN-**T1 -***/H68
technical type		CDK1LI8	CDM2LI8	CDP2LI8
transducer frequency	MHz	0.5	1	2
<b>inner pipe diameter d</b>				
min. extended	inch	3.9	2	0.98
min. recommended	inch	7.9	3.9	2
max. recommended	inch	78.7	39.4	15.7
max. extended	inch	94.5	47.2	18.9
<b>pipe wall thickness</b>				
min.	inch	0.2	0.1	0.05
<b>material</b>				
housing		PEEK with stainless steel cover 316Ti		
contact surface		PEEK		
degree of protection		IP68 <sup>1</sup>		
<b>transducer cable</b>				
type		2550		
length	ft	39		
<b>dimensions</b>				
length l	inch	5.12	2.76	
width b	inch	2.13	1.26	
height h	inch	3.29	1.81	
dimensional drawing				
weight (without cable)	lb	0.95	0.19	
pipe surface temperature	°F	-40 to +212		
ambient temperature	°F	-40 to +212		
temperature compensation		x		

<sup>1</sup> test conditions: 3 months/29 psi (65 ft)/36 °F

### Transducer mounting fixture

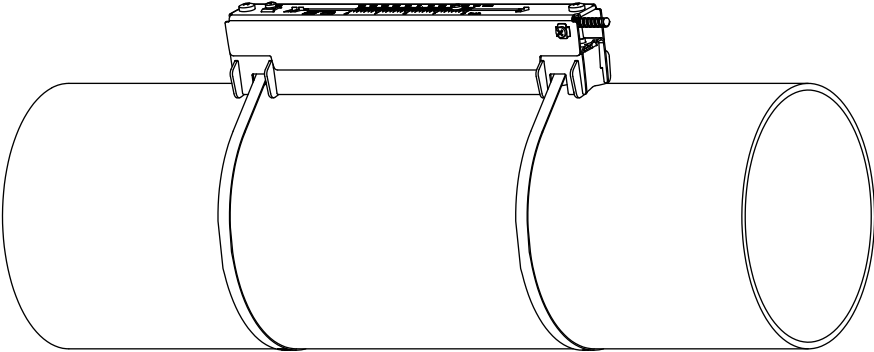
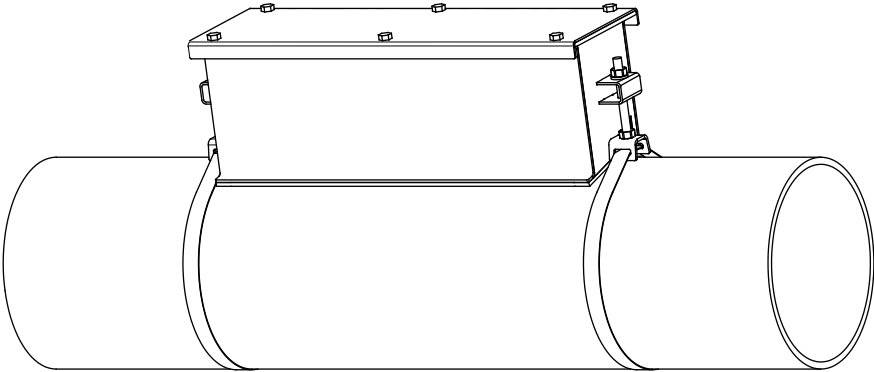
<p><b>Variofix L (VL)</b></p> 	<p>material: stainless steel 316Ti, 316L, 17-7PH          inner length:  <b>VLK:</b> 13.7 inch,          option IP68: 14.5 inch  <b>VL(MP):</b> 9.2 inch  <b>VLQ:</b> 6.9 inch          dimensions:  <b>VLK:</b> 16.65 x 3.54 x 3.66 inch          option IP68: 17.44 x 3.7 x 4.13 inch  <b>VL(MP):</b> 12.17 x 2.24 x 2.48 inch  <b>VLQ:</b> 9.72 x 1.69 x 1.85 inch</p>
<p><b>PermaLok (PL)</b></p> 	<p>material: stainless steel 316          dimensions:  <b>PL(GHK)-RL:</b> 19.25 x 3.9 x 3.95 inch  <b>PL(GHK)-DS:</b> 13.25 x 3.85 x 3.95 inch  <b>PL(MP):</b> 25.25 x 3.08 x 3.15 inch  <b>PLQ:</b> 13.37 x 2.68 x 2.4 inch          weight:  <b>PL(GHK)-RL:</b> 6 lb  <b>PL(GHK)-DS:</b> 4.2 lb  <b>PL(MP):</b> 6.6 lb  <b>PLQ:</b> 2.8 lb</p>

### Coupling materials for transducers

type	ambient temperature °F
coupling pad type VT	14 to +392

### Connection systems

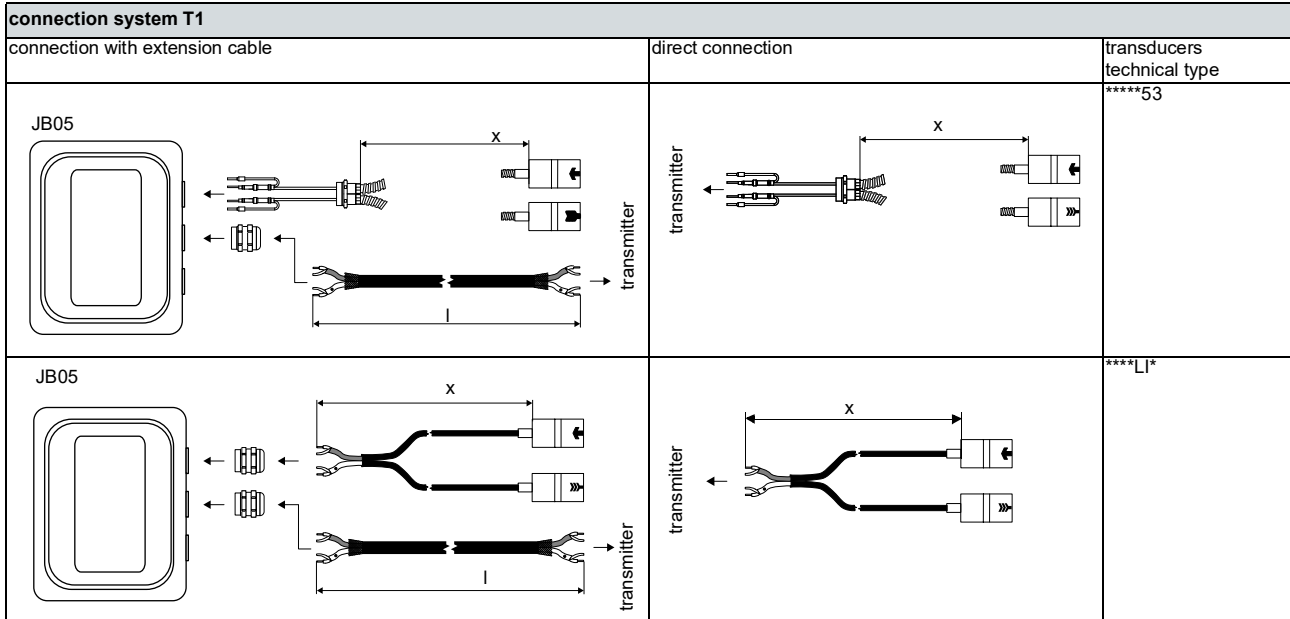

### Cable

transducer cable		
type		1699                      2550
weight	lb/ft	0.06                      0.02
ambient temperature	°F	-67 to +392              -40 to +212
cable jacket		
material		PTFE                      PUR
outer diameter	inch	0.11                      0.2 ±0.01
thickness	inch	0.01                      0.04
color		brown                      gray
shield		x                              x
sheath		
material		stainless steel 316Ti      -
outer diameter	inch	0.31                      -

extension cable		
type		2615
weight	lb/ft	0.12
ambient temperature	°F	-22 to +158
properties		halogen-free fire propagation test according to IEC 60332-1 combustion test according to IEC 60754-2
cable jacket		
material		PUR
outer diameter	inch	0.47
thickness	inch	0.08
color		black
shield		x

### Cable length

transducer frequency	K		M, P		Q	
	x	l	x	l	x	l
*D***5*	ft 16	≤ 984	13	≤ 984	9	≤ 295
*L***5*	ft 29	≤ 984	29	≤ 984	29	≤ 295
****L*	ft 39	≤ 984	39	≤ 984	-	-

x = transducer cable length

l = max. length of extension cable (depending on the application)

# Junction box

## Technical data

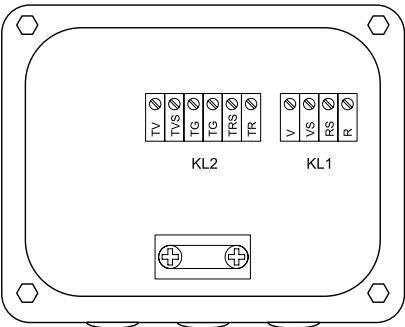
JB05																													
weight	lb	2.6 lb																											
fixation		wall mounting optional: 2" pipe mounting																											
material																													
housing		stainless steel 316L																											
gasket		silicone																											
degree of protection		IP66/IP67																											
ambient temperature	°F	-40 to +176																											
<div style="display: flex; justify-content: space-between;"> <div style="width: 45%;"> <p><b>Connection</b></p>  </div> <div style="width: 45%;"> <p><b>Transducers</b></p> <table border="1"> <thead> <tr> <th>terminal strip</th> <th>terminal</th> <th>connection</th> <th>transducer</th> </tr> </thead> <tbody> <tr> <td rowspan="4">KL1</td> <td>V</td> <td>signal</td> <td rowspan="2">↑</td> </tr> <tr> <td>VS</td> <td>internal shield</td> </tr> <tr> <td>RS</td> <td>internal shield</td> <td rowspan="2">↕</td> </tr> <tr> <td>R</td> <td>signal</td> </tr> </tbody> </table> <p><b>Extension cable</b></p> <table border="1"> <thead> <tr> <th>terminal strip</th> <th>terminal</th> <th>connection</th> </tr> </thead> <tbody> <tr> <td rowspan="4">KL2</td> <td>TV</td> <td>signal</td> </tr> <tr> <td>TVS</td> <td>internal shield</td> </tr> <tr> <td>TRS</td> <td>internal shield</td> </tr> <tr> <td>TR</td> <td>signal</td> </tr> </tbody> </table> </div> </div>			terminal strip	terminal	connection	transducer	KL1	V	signal	↑	VS	internal shield	RS	internal shield	↕	R	signal	terminal strip	terminal	connection	KL2	TV	signal	TVS	internal shield	TRS	internal shield	TR	signal
terminal strip	terminal	connection	transducer																										
KL1	V	signal	↑																										
	VS	internal shield																											
	RS	internal shield	↕																										
	R	signal																											
terminal strip	terminal	connection																											
KL2	TV	signal																											
	TVS	internal shield																											
	TRS	internal shield																											
	TR	signal																											

## Dimensions

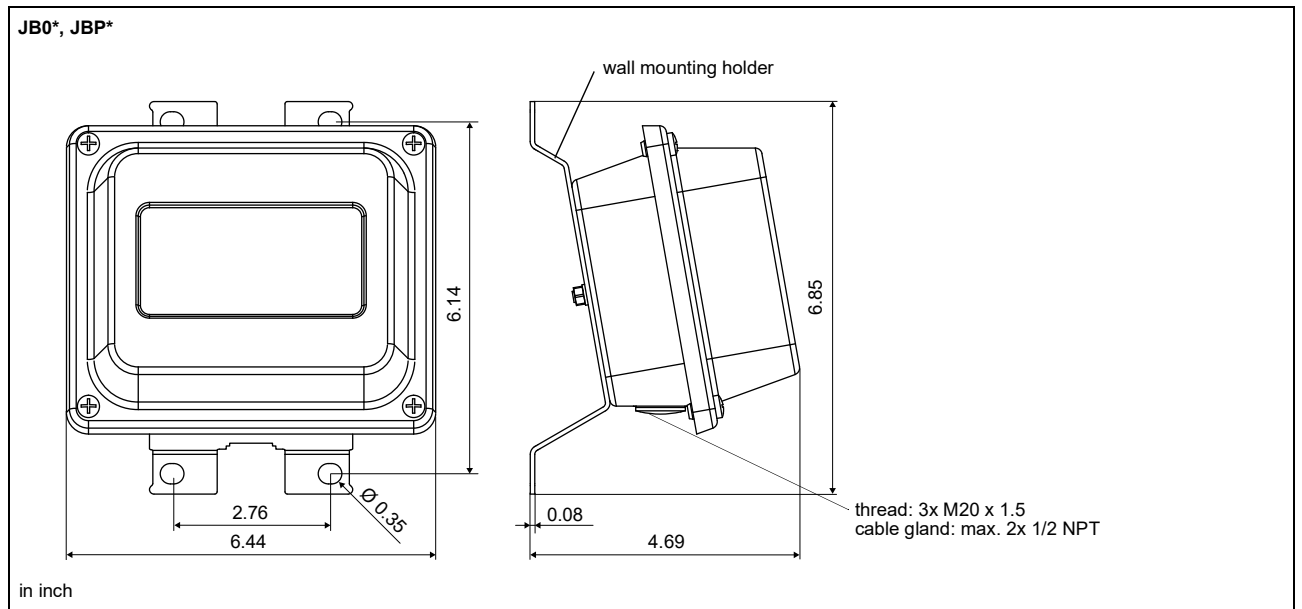

## 2" pipe mounting kit

JB\*\*

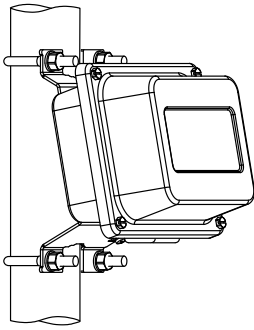

item number: 751035-2

For more information: **Emerson.com**

© 2025 Emerson. All rights reserved.

Emerson Terms and Conditions of Sale are available upon request.  
The Emerson logo is a trademark and service mark of Emerson Electric Co. Flexim is a mark of one of the Emerson family of companies. All other marks are the property of their respective owners.