

Operating Instructions

RIA16

Field Indicator

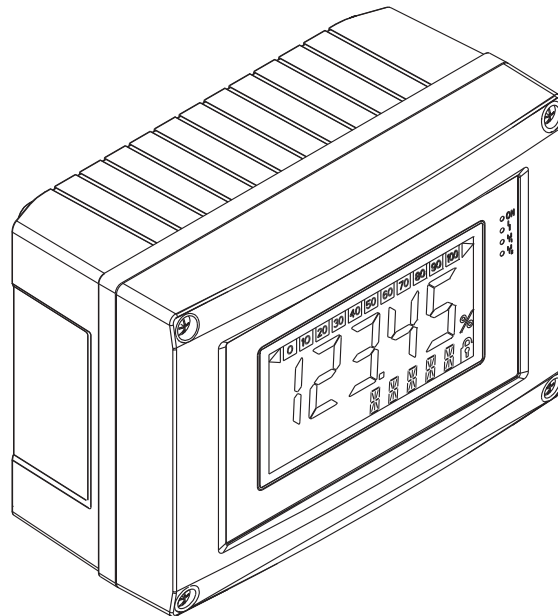

Brief operating instructions

For quick and easy commissioning:

Safety instructions	→ 4
▼	
Installation	→ 7
▼	
Wiring	→ 10
▼	
Display and operating elements	→ 13
▼	
Device configuration	→ 17
Device configuration - Explanation and application of all adjustable device functions with the related ranges of values and settings.	

1 Safety instructions

1.1 Designated use

- ▶ The device is a configurable field indicator with one sensor input.
- ▶ The device is designed for installation in the field.
- ▶ The manufacturer does not accept liability for damage caused by improper or non-designated use.
- ▶ Safe operation is only guaranteed if the Operating Instructions are observed and adhered to.
- ▶ Only operate the device in the permitted temperature range.

1.2 Installation, commissioning, operation

Note the following points:

- Mounting, electrical installation, commissioning and maintenance of the device must only be carried out by trained technical personnel authorised to perform such work by the owner-operator. They must have read and understood these Operating Instructions and must follow the instructions they contain.
- The device must be operated by persons authorised and trained by the facility's owner-operator. Strict compliance with the instructions in these Operating Instructions is mandatory.
- The installer must ensure that the measuring system is correctly wired in accordance with the wiring diagrams.
- Invariably, local regulations governing the opening and repair of electrical devices apply.

1.3 Operational safety

The measuring system complies with the general safety requirements in accordance with EN 61010 and the EMC requirements of EN 61326 and NAMUR Recommendations NE 21.

Hazardous area

Measuring systems for use in hazardous environments are accompanied by separate "Ex documentation", which is an integral part of these Operating Instructions. Strict compliance with the installation instructions and connection values as stated in this supplementary documentation is mandatory.

1.4 Return





To reuse later or in case of repair, the device must be packed in protective packaging, preferably the original packaging. Repairs must only be carried out by your supplier's service organisation or specially trained personnel.

An overview of the service network is provided on the back page of these Operating Instructions. Enclose a note describing the fault and the application when sending the unit in for repair.

Please inform the haulier and the supplier if the goods are damaged in transport.

1.5 Notes on safety conventions and icons

Always refer to the safety instructions in these Operating Instructions labeled with the following symbols:

Symbol	Meaning
 <small>A0011190-EN</small>	WARNING! This symbol alerts you to a dangerous situation. Failure to avoid this situation can result in serious or fatal injury.
 <small>A0011191-EN</small>	CAUTION! This symbol alerts you to a dangerous situation. Failure to avoid this situation can result in minor or medium injury.
 <small>A0011192-EN</small>	NOTICE! This symbol contains information on procedures and other facts which do not result in personal injury.
	ESD - Electrostatic discharge Protect the terminals against electrostatic discharge. Failure to comply with this instruction can result in the destruction of parts or malfunction of the electronics.
 <small>A0011193</small>	Indicates additional information, Tip

2 Identification

2.1 Device designation

2.1.1 Nameplate

The right device?

Compare the order code on the nameplate of the device to that on the delivery papers.

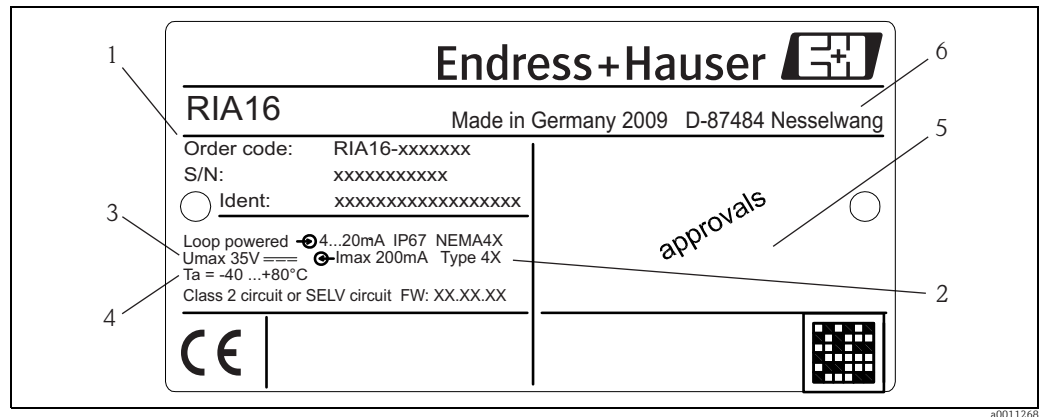

Fig. 1: Nameplate of the field indicator (example)

- 1 Designation, order code and serial number of the device
- 2 Degree of protection and approvals
- 3 Power supply and output signal
- 4 Ambient temperature
- 5 Approvals
- 6 Manufacturer address and date of manufacture

2.2 Scope of delivery

The scope of delivery of the field indicator comprises:

- Field indicator
- Brief operating instructions as hardcopy
- Operating instructions on CD-ROM
- ATEX Safety Instructions for deploying a device permitted for use in hazardous areas, optional
- Accessories (eg. pipe mounting kit), see chapter 'Accessories'

2.3 Certificates and approvals

CE mark, declaration of conformity

The field indicator is designed to meet state-of-the-art safety requirements, has been tested and left the factory in a condition in which it is safe to operate.

The device meets the relevant standards and directives as per EN 61 010 "Safety requirements for electrical equipment for measurement, control and laboratory use".

The device described in these Operating Instructions thus meets the legal requirements of the EU directives. The manufacturer confirms that the device has been tested successfully by affixing the CE mark.

3 Function and system design

The field indicator is directly looped into the 4 to 20 mA measuring circuit. The energy required is taken from the loop of the measuring circuit. The device records an analog measured value and displays it on a clearly legible LC display. In addition, a bargraph displays the measured value graphically. The illuminated display makes it easier to read the display in dark surroundings.

4 Installation

4.1 Incoming acceptance, transport, storage

The permitted ambient and storage conditions must be observed. The precise specifications can be found in Section "Technical data".

4.1.1 Incoming acceptance

On receipt of the goods, check the following points:

- Are the packaging or contents damaged?
- Is anything missing from the delivery? Compare the scope of delivery with the information you specified in the order. See also section 2.2 "Scope of delivery".

4.1.2 Transportation and storage

Note the following points:

- Pack the device so that is protected against impact for storage and transportation. The original packaging provides optimum protection.
- The permitted storage temperature range is -40 to +80°C (-40 to +176 °F); it is possible to store the device in the limit temperature ranges for a limited period (maximum 48 hours).

4.2 Installation conditions

The process indicator is designed to be used in the field.

The orientation is determined by the readability of the display. Cable entries are located on the bottom of the device.

Operational temperature range:

-40 to +80 °C (-40 to +176 °F)

-20 to +80 °C (-4 to +176 °F) when the Open Collector output is used



If the device is operated in the upper temperature limit range, this reduces the operating life of the indicator.

The display may react slowly at temperatures below -20 °C (-4 °F).

Readability of the display cannot be guaranteed at temperatures below -30 °C (-22 °F).

4.2.1 Dimensions

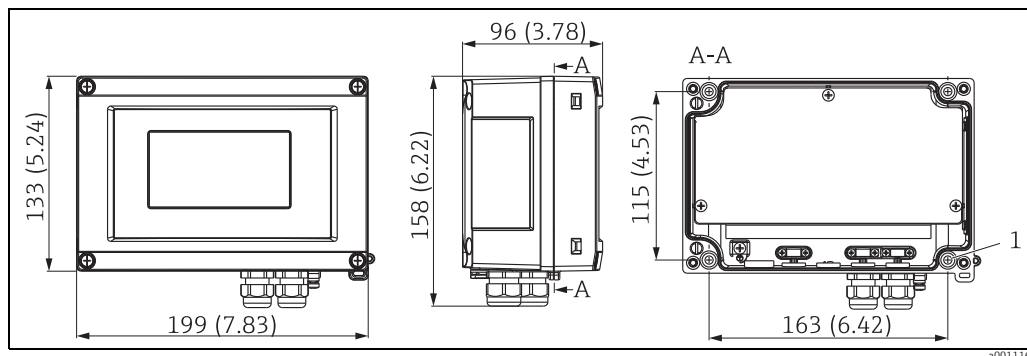



Fig. 2: Installation dimensions; dimensions in mm (in)

A = Bore hole for mounting to wall or optional mounting plate with 4 screws $\varnothing 5$ mm (0.2 in.)

4.2.2 Installation location

Information on conditions that must be present at the installation location to mount the device correctly can be found in Section 'Technical data'. These include the ambient temperature, degree of protection, climate class etc.

4.3 Mounting instructions



The device can be mounted directly on the wall or the optional mounting plate can be used for wall or pipe mounting (→  3 and →  4).

4.3.1 Direct wall mounting

Proceed as follows to mount the device directly on the wall:

- Drill 4 holes
- Attach the device to the wall with 4 screws ($\varnothing 5$ mm (0.2 in.)).

4.3.2 Pipe mounting

The mounting bracket is suited for pipes with a diameter between 25.4...127 mm (1...5 in.). The mounting kit consists of a mounting plate (item 1), 2 clamps (item 2) and 4 screws (item 3) (→  3 and →  4).

To install the field indicator on a pipe, proceed as follows:

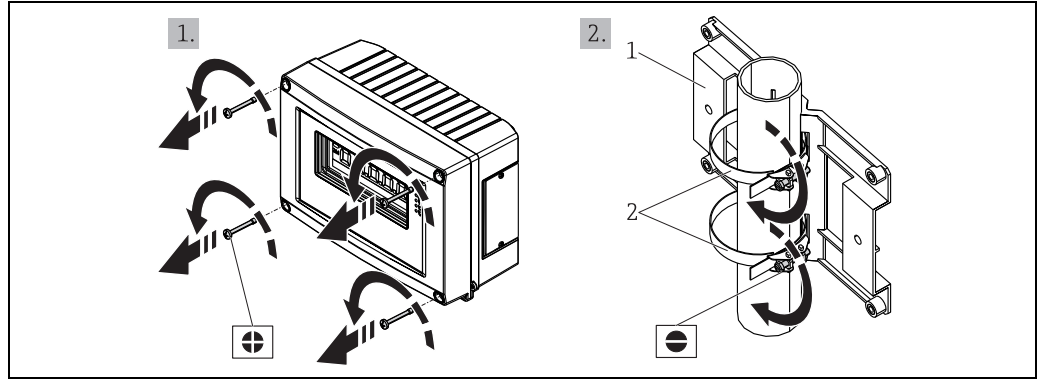

Fig. 3: Mounting the field indicator on a pipe with mounting bracket, steps a-b

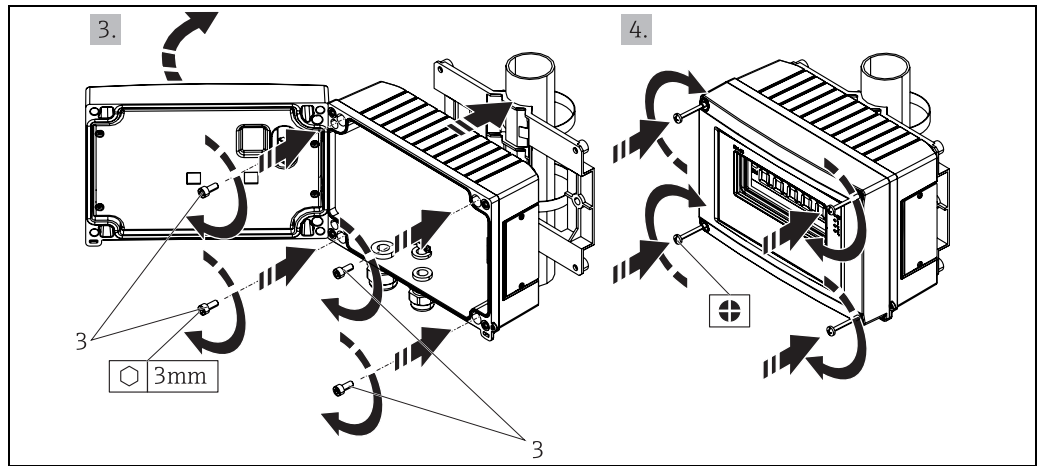

Fig. 4: Mounting the field indicator on a pipe with mounting bracket, steps c-d

- Mounting kit, consisting of:
 1: Mounting plate
 2: Clamps for pipe mounting
 3: 4 screws

4.4 Post-installation check

After installing the device, always run the following final checks:

Device condition and specifications	Notes
Is the device damaged?	Visual check
Is the sealing ring undamaged?	Visual check
Is the device fixed securely to the wall or mounting plate?	-
Is the front cover fixed tightly?	-
Does the device comply with the measurement point specifications, such as ambient temperature, measurement range etc.?	See Section 'Technical data'

5 Wiring

⚠ WARNING

Loss of Ex approval if device is not properly connected

- ▶ All relevant instructions and connection diagrams in the specific Ex documentation for these Operating Instructions must be observed. Your local E+H representative is available for assistance if required.

Firstly, open the housing of the field indicator:

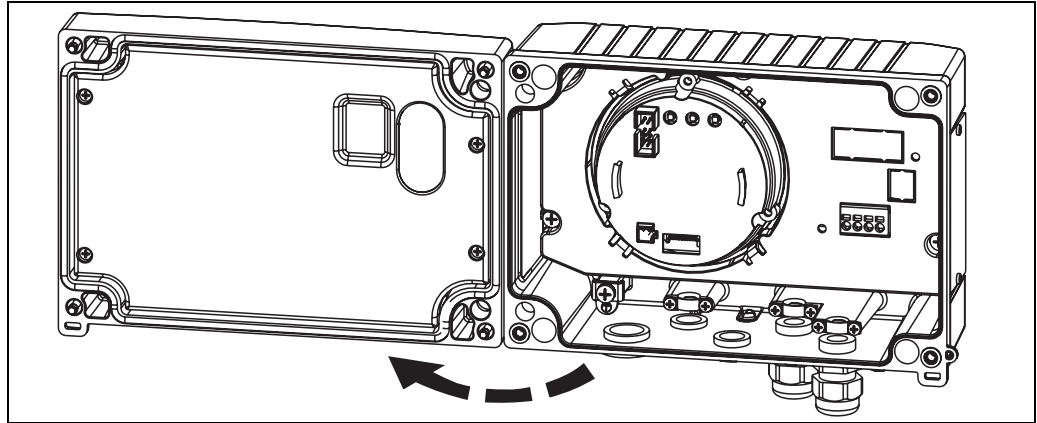

Fig. 5: Opening the housing of the field indicator

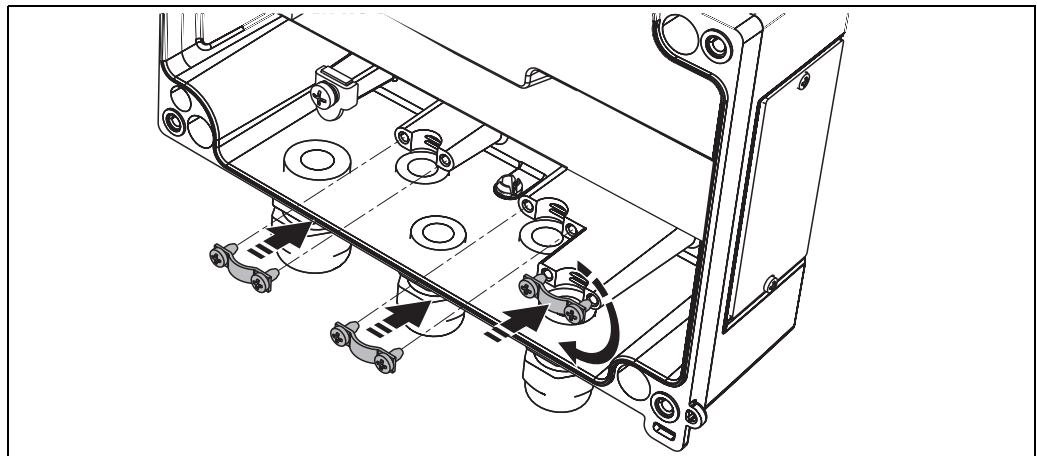

Fig. 6: Installing the cable shield grounding clamps (aluminum housing only)

5.1 Quick wiring guide

Terminal assignment

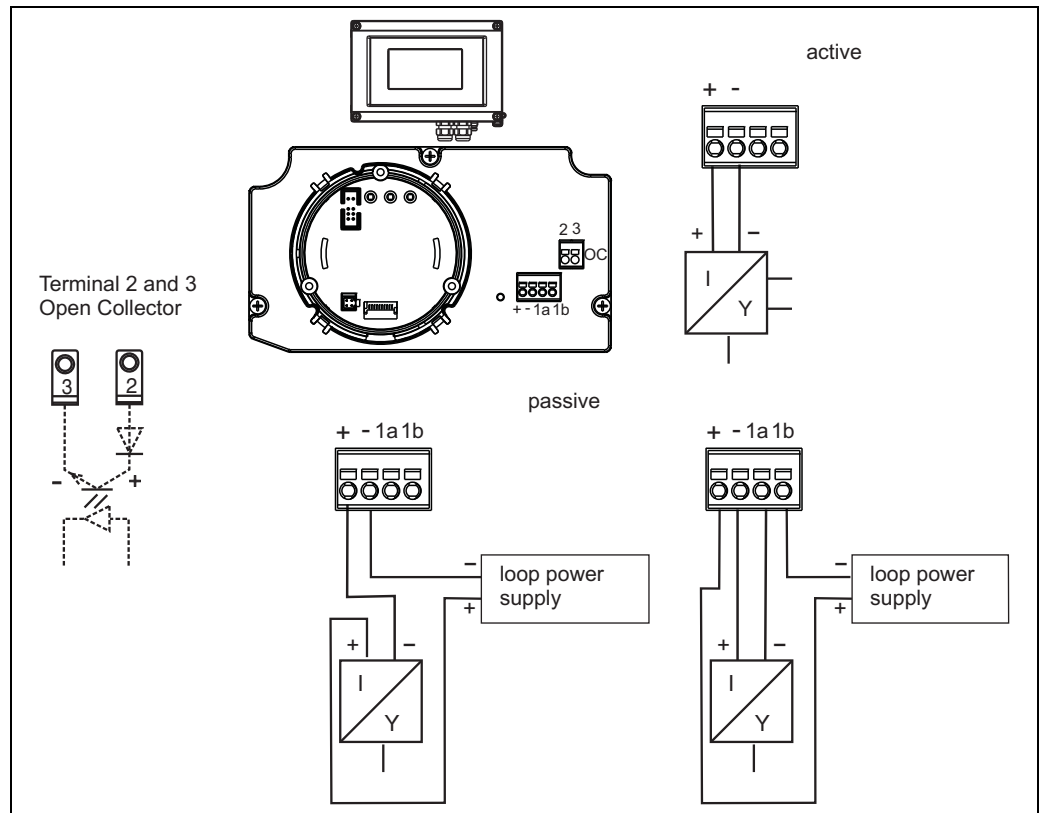

Fig. 7: Terminal assignment

Terminal	Terminal assignment	Input and output
+	Measuring signal (+) 4 to 20 mA	Signal input
-	Measuring signal (-) 4 to 20 mA	Signal input
1a, 1b	Terminal for further instrumentation	Support terminal
2	Digital limit switch (collector)	Switch output
3	Digital limit switch (emitter)	Switch output

5.2 Electrical connection

Both the terminal assignment and the connection values of the field indicator correspond to those of the Ex-version. The device is only designed for operation in a 4 - 20 mA measuring circuit. There must be potential equalisation along the circuits (within and outside the hazardous area).

5.3 Degree of protection

The devices fulfill all the requirements for IP 67 degree of protection. Compliance with the following points is mandatory following installation or servicing in order to ensure that IP 67 protection is maintained:

- The housing seal must be clean and undamaged when inserted into the seal groove. The seal may have to be cleaned, dried or replaced.
- The cables used for connection must be of the correct specified outside diameter (e.g. M16 x 1.5, cable diameter from 5 to 10 mm).
- Replace any unused cable entries with dummy plugs.
- The grommet used should not be removed from the cable entry.
- The housing cover and the cable entry must be well tightened.
- Install the device upright in such a way that the cable entries point downwards.

5.4 Post-connection check

Perform the following checks after completing electrical installation of the device:

Device condition and specification	Note
Are the device or the cables damaged?	Visual inspection
Electrical connection	Note
Is the cable type route completely isolated - without loops and cross-overs?	-
Are the cables strain relieved?	-
Is the terminal assignment correct? Compare with the connection diagram of the terminal block	→ Chap. 5.1
Are all terminal screws tightened?	Visual inspection
Is the cable gland sealed?	Visual inspection
Is the housing cover tightened?	Visual inspection

6 Operating the field indicator

6.1 Display and operating elements

6.1.1 Display

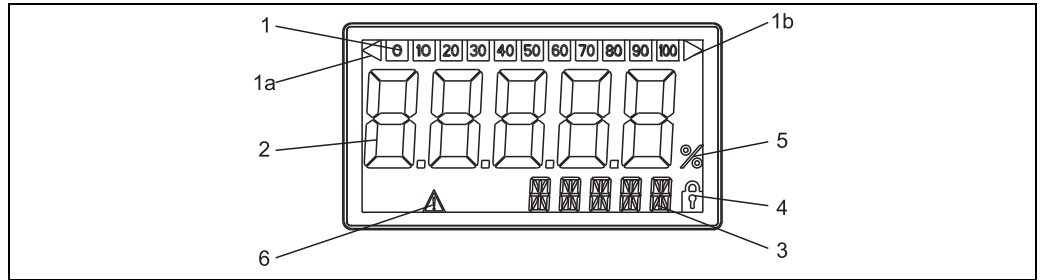

Fig. 8: LC display of the field indicator

a0011163

6.1.2 Display symbols

1	Bargraph display
1a	Indicator for measuring range undershoot
1b	Indicator for measuring range overshoot
2	Measured value display Digit height 26 mm (1.02")
3	14-segment display for units and messages)
4	Symbol 'Programming disabled'
5	Unit '%'
6	'Fault' indicator

6.2 Configuration via operating keys

▲ WARNING

Loss of explosion protection when housing is open

- The device must be configured outside the hazardous area.

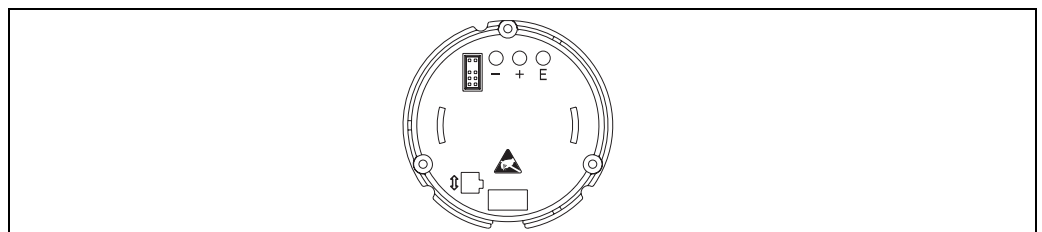

Fig. 9: Operating keys of field indicator ("+", "-", "E")

a0011261

To configure the device, open the housing cover. The keys (+, -, E) can now be accessed. During configuration, the display must be connected to the electronics unit.

6.2.1 Navigation

The operating fields are split into 2 levels.

Menu: Various menu items can be selected on the menu level. The individual menu items are an aggregation of the associated operating functions.

Operating function: An operating function can be regarded as an aggregation of the operating parameters. The operating functions are used to operate and configure the device.

Operating keys:

'E' Enter key: Press and hold down the E key for longer than 3 seconds to enter the programming menu.

- Selecting operating functions.
- Accepting values.
- If the E key is pressed for longer than 3 seconds, the system returns directly to the Home position. Beforehand, you are asked whether the data entered up to now should be saved.
- Saving data entered.

Selection keys '+/-':

- Selecting the menus.
- Configuring parameters and numerical values.
- After selecting the operating function, the value is entered or the setting changed by pressing the + or - keys.



If the keys are pressed for an extended period, the digits are changed with increasing speed.

If the + or - keys are pressed in the "Program Name" and "Program Version" operating position, the display is scrolled horizontally as these positions (7-digit) cannot be displayed completely in the 14-segment display.

6.2.2 Programming in the operating matrix

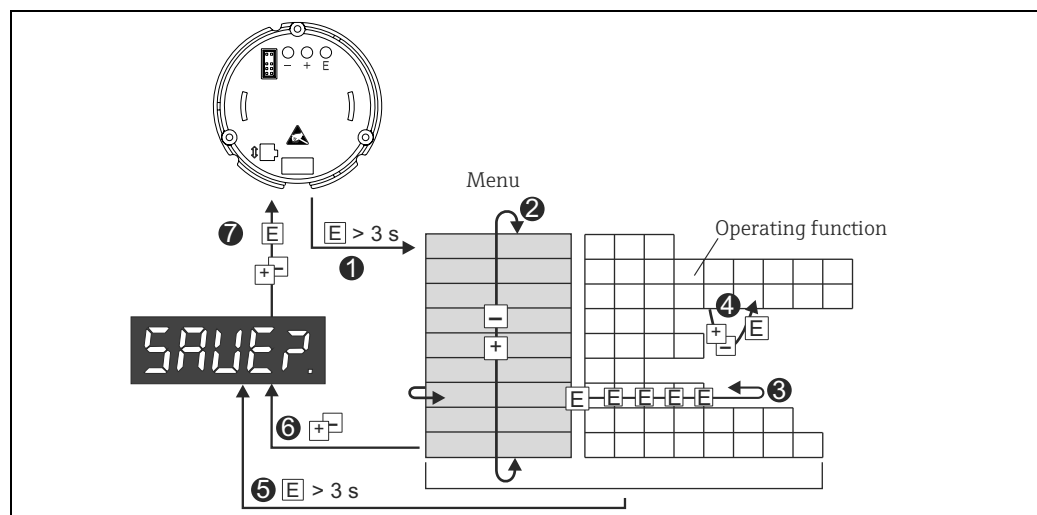

Fig. 10: Programming the field indicator

- ① Enter the operating matrix
- ② Menu (select with "+" or "-" key)
- ③ Select the operating functions
- ④ Enter parameters in the edit mode (enter/select data with "+" or "-" and accept with "E").
- ⑤ Go directly to the Home position.
 - Beforehand, you are asked whether the data entered up to now should be saved.
- ⑥ Exit the menus with "+/-". You are asked whether the data entered should be saved.
- ⑦ Prompt to save data (select YES/NO with "+" or "-" key and confirm with "E").

6.3 Operating matrix

Menu	Operating function		Operating function		Operating function	
	Parameter	Default / Choice	Parameter	Default / Choice	Parameter	Default / Choice
Analog input INPUT	Curve CURV		Signal damping DAMP		Dec. point of measured val. DI DP	
	Linear Quadratic	LINAR SQRT	0 to 99 s	0	99.999 999.99 9999.9 99999	3 DEC 2 DEC 1 DEC 0 DEC
	Scaling measured val. 4 mA DI LO		Scaling measured val. 20 mA DI HI		Measured value offset OFFST	
	-9999 to 99999	0.0	-9999 to 99999	100.0	-9999 to 99999	0.0
Display DISPL	Dimension DIM		Dimension** DTEXT			
	none % User-defined	NO % TEXT	XXXXX			
Limit LIMIT	Operating mode MODE		Switching setpoint SETP			
	off Min.safety with alarm Max.safety with alarm Alarm	OFF MIN MAX ALARM	-9999 to 99999	0.0		
	Hysteresis HYST		Response delay DELY			
	-9999 to 99999	0.0	0-99 s	0		
Operating parameters PARAM	User code CODE		Program name PNAME		Firmware version FWVER	
	0000 to 9999	0000				
	NAMUR NAMUR		NAMUR 3.6* N_360		NAMUR 3.80* N_380	
	Default Edit	dEF Edit	0 to NAMUR 20.5	3.60	NAMUR 3.6 to NAMUR 20.5	3.80
	NAMUR 20.5* N2050		NAMUR 21.0* N2100		Test TEST	
	NAMUR 3.80 to NAMUR 21.0	20.50	NAMUR 20.5 to 25 mA	21.00	off Open Collect. Display	OFF OUT DISP
Service SERV	Service code SCODE		Parameter reset*** PRSET			
		----	Yes No	Yes No		
*) only if "Edit" has been selected for NAMUR **) only if "TEXT" has been selected for DIMENSION ***) only available for service personnel						

6.4 Configuration via interface & FieldCare Device Setup PC configuration software

⚠ WARNING

Loss of explosion protection when housing is open

- ▶ The device must be configured outside the hazardous area.

⚠ CAUTION

Undefined switching of outputs and relays during configuration

- ▶ While configuring with FieldCare the device may assume undefined states.

To configure the device with the FieldCare Device Setup software, connect the device to your PC. You need a special interface adapter for this purpose - the Commubox FXA291 (see Chapter 'Accessories').

The 4-pin connector of the interface cable must be plugged into the corresponding socket inside the device and the USB connector must be plugged into a free USB slot on the PC.

Connection establishment

When connecting the device, the device DTM is not automatically loaded in FieldCare, i.e. the device has to be added manually.

- Firstly, add the Communication DTM "PCP (Readwin) TXU10 / FXA291" to an empty project.
- In the Comm DTM settings, set the baud rate to 2400 baud and select the COM-port used.
- Add the RIA14/16 Version Vx.xx.xx device DTM to the project using the "Add device..." function.

Online configuration is not possible with the RIA14/RIA16.

- To then configure the device itself, follow these Operating Instructions for the device. The entire Setup menu, i.e. all the parameters listed in these Operating Instructions, can also be found in the FieldCare Device Setup.

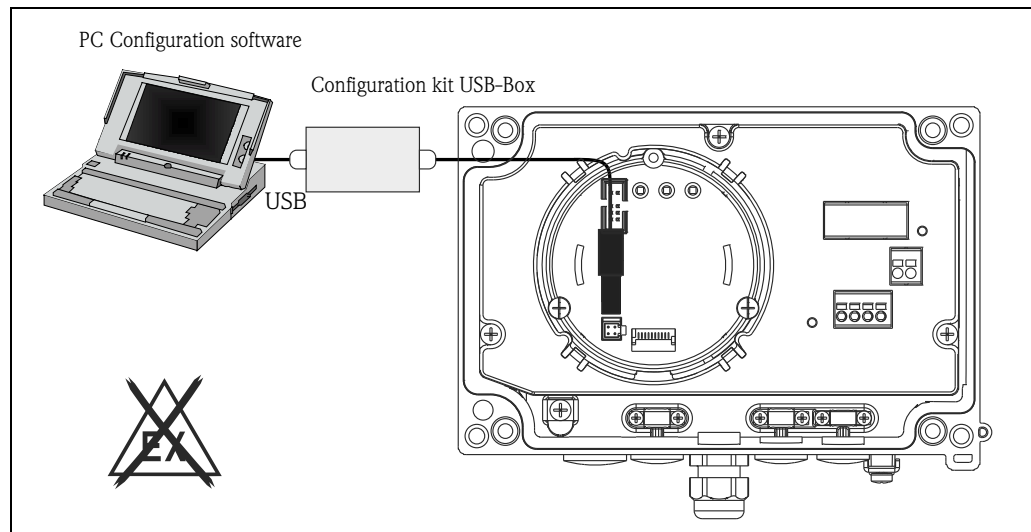

Fig. 11: Configuring the field indicator via interface adapter



In general, it is possible to overwrite parameters with the FieldCare PC software and the appropriate device DTM even if access protection is active.

If access protection by means of a code should be extended to the software, this function should be activated in the extended device setup.

7 Device configuration

Description of operating functions

The following table shows the menus available for the field indicator. These are explained in detail in the sections specified.

Section	Function	As shown on the display
Section 7.1	Data processing	INPUT
Section 7.2	Display	DISPL
Section 7.3	Limit values	LIMIT
Section 7.4	Other settings	PARAM
Section 7.5	Service level	SERV

7.1 Data processing (INPUT)

7.1.1 Input range

INPUT → CURVE → Options: Linear (LINAR) or square root (SQRT).

The input range is a 4 - 20 mA signal.

Select the type of input signal here (linear or quadratic).

7.1.2 Damping

INPUT → DAMP → Options: 0 - 99 (0 = no damping)

- Measured value damping can be set between 0 and 99 s.
- Only whole numbers can be entered.
- The factory setting is 0 (no damping).

7.1.3 Measured value scaling

Name	Description
Measured value decimal point 'DI DP'	Indicates the number of places after the decimal point for the numerical display of the measuring range. – Selection range 0 - 3 places after decimal point – Default: 1 place after decimal point If the number of spaces after the decimal point is increased, the value for all the dependent operating parameters must be recalculated based on the formula $\text{new value} = \text{old value} * 10^{\text{PD}_{\text{new}} - \text{PD}_{\text{old}}}$. If the value of one of the dependent operating parameters is < -19999 or > 99999, the number of places after the decimal point cannot be increased and error message C561 is shown on the display.
Measured value 0 % 'DI LO'	Indicates the display value for the 4 mA value. – Value range -19999 to 99999 – Default: 0.0
Measured value 100 % 'DI HI'	Indicates the display value for the 20 mA value. – Value range -19999 to 99999 – Default: 100.0
Measured value offset 'OFFST'	This is used to correct the display measured value. The offset is added to the measured value. – Value range -19999 to 99999 – Default: 0.0

 Measured value 0 % and 100 % may not be identical. However, the 0 % measured value can be larger than the 100 % measured value (invert).

7.2 Display (DISPL)

7.2.1 Dimension

DIM → Options: NO, °C, K, °F, % or TEXT

One of the units permanently stored in the display can be selected - K, °C, °F, %. Alternatively, any unit can be configured on the 14-segment display (TEXT).

The character set consists of the following characters:

Characters A-Z, abcdhijlmnoruvwy, the digits 0-9 and the special characters: - + * / ()

7.2.2 Configuring the editable unit (DTEXT)

DIM → DTEXT → Enter a unit that can be edited as required

To configure the editable unit, all 5 points on the 14-segment display have to be configured. Press the E key to move on to edit the next letter. Accept the set unit with "E".

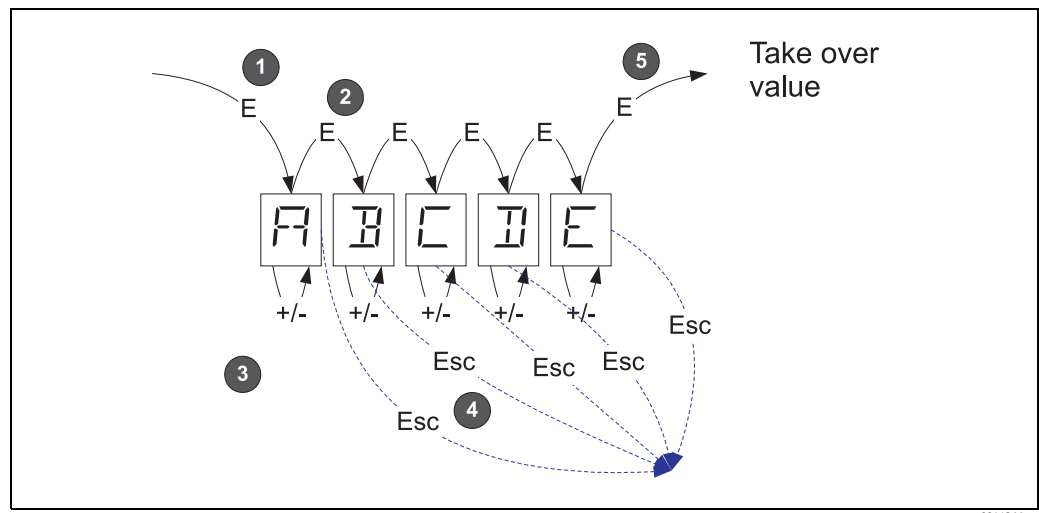

Fig. 12: Configuring the editable unit

No.	Description
①	Press the E key to select the desired operating function.
②	Press the E key to select the next point of the 5-digit 14-segment display.
③	Press the + or - key to select the next/previous character for the point selected.
④	If you press the +/- keys simultaneously, data entry is aborted and the operating function is displayed.
⑤	When you confirm the 5th position of the display with E, the entry is accepted and you change back to the operating function.

7.3 Limit values (LIMIT)

In the event of limit value violation or a fault, the OC output is switched currentless in accordance with the quiescent current principle.

In the event of a limit value violation MIN (lower limit) 'LIMIN' is displayed in the 14-segment display. In the event of a limit value violation MAX (upper limit) 'LIMAX' is displayed.

7.3.1 Operating mode

LIMIT → MODE → Selection OFF, MIN, MAX, ALARM

Select the 'Limit and fault monitoring' operating mode

Options for selection: MIN, MAX, ALARM or OFF

- MIN = lower limit value
- MAX = upper limit value
- ALARM = in the event of a device error
- Default: OFF = no limit value or fault monitoring

7.3.2 Switching threshold

LIMIT → SETP → Options -19999 to 99999

Measured value at which a change in the switching status occurs.

- Value range: -19999 to 99999
- Default: 0

7.3.3 Hysteresis

LIMIT → HYST → Options -19999 to 99999

For entering the hysteresis for the threshold with minimum/maximum safety.

- Value range: -19999 to 99999
- Default 0

7.3.4 Response delay

LIMIT → DELY → Options 0 to 99 s

For setting the response delay (in seconds) of the limit value event after reaching the switching threshold

- Value range: 0 - 99 s
- Default 0

7.4 Other settings (PARAM)

7.4.1 User code - locking

PARAM → CODE → User code entry

The device can be locked to protect the processes against undesired and unauthorised effects. The device parameters are protected by a 4-digit user code and cannot be altered without entering the code.

User code: a user code already assigned can only be altered if the old code is entered to enable the device. The new code can then be configured.

- Value range: 0000 to 9999
- Default: 0

7.4.2 Program information

Name	Description
Program name 'PNAME'	Displays the name of the software loaded in the device (7-digit) Note! Display cannot be edited
Firmware version 'FWVER'	Displays the version of the firmware loaded in the device (8-digit) Note! Display cannot be edited



Press the + or - key to scroll horizontally through the 7 or 8-digit display values.

7.4.3 Alarm limits (NAMUR)

PARAM → NAMUR

The alarm limits are set to NAMUR values at the factory.

These values can

- be used as default values (DEF) or
- be edited freely (EDIT)

The following operating positions can be altered if operating item 'Edit' was selected.

Name	Description
NAMUR 3.6	Value range: 0 mA to < Namur 3.8 Default: 3.60
NAMUR 3.8	Value range: Namur 3.6 < x < Namur 20.5 Default: 3.80
NAMUR 20.5	Value range: Namur 3.8 < x < Namur 21.0 Default: 20.50
NAMUR 21.0	Value range: Namur 20.5 < x < 25 mA Default: 21.00

The Namur limits are indicated in ascending order.

7.4.4 Test (TEST)

PARAM → TEST → Options OFF, OUT, DISP

Certain device functions can be tested automatically.

OFF (default)

Open collector: OUT

Display: DISP

7.5 Service level (SERV)

This level can only be selected after entering the service code (only available to service personnel).

7.5.1 Resetting the device (reset)

PRSET - perform reset

Service can reset the settings to the default values.

Reset: After selecting YES, the operating parameters are set to the factory default values.

- Options: Yes or No
- Default: No

If the default values are set, the option selected is automatically reset to No.

8 Commissioning

8.1 Function check

Prior to commissioning, the screw cap must be tightened and secured with the cover clamp. Any openings not used must be sealed.

Make sure all connected wires are secure.

To ensure correct functioning, the screws of the terminals must be tightened. The device is now operational.

During device initialization, all the segments are shown on the display for approx. 1 second.

9 Maintenance

No special maintenance work is required on the device.

10 Accessories

Various accessories, which can be ordered with the device or subsequently from Endress+Hauser, are available for the device. Detailed information on the order code in question is available from your local Endress+Hauser sales center or on the product page of the Endress+Hauser website: www.endress.com

10.1 Device-specific accessories

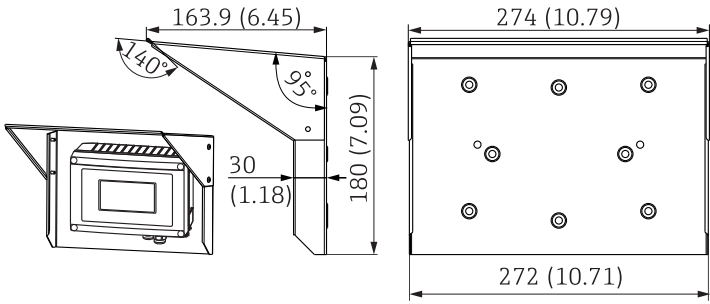
Designation	Description
Mounting kit wall/pipe (for pipes Ø1-5")	<ul style="list-style-type: none"> ▪ Plastic housing ▪ Alu housing
Protective cover	 <p style="text-align: center;">Fig. 13: Dimensions in mm (in)</p> <p style="text-align: right; font-size: small;">A0021548</p>

10.2 Communication-specific accessories

Designation
Interface cable
Commubox TXU10 incl. FieldCare Device Setup and DTM Library
Commubox FXA291 incl. FieldCare Device Setup and DTM Library

11 Trouble-shooting

The following section provides you with an overview of possible causes of error to help you in trouble-shooting.

11.1 Trouble-shooting instructions

▲ WARNING

Loss of explosion protection when device is open

- ▶ No error diagnosis with open device in explosion hazardous areas.

11.2 Process error messages

Errors occurring during the self test or during operation are shown immediately on the display. Acknowledgeable error messages are deleted after pressing a key. A fault is present if the hardware for writing and reading data (EEPROM) is defective or if data cannot be read properly from the EEPROM.

Error code	Description
C561	Display overflow
F041	Sensor / cable open circuit (input < 3.6 mA or > 21 mA). Warning symbol 'Failure' is displayed.
F045	Sensor error (2 mA < input ≤ 3,6 mA or input ≥ 21 mA). Warning symbol 'Failure' is displayed.
F101	Signal underrange (input between 3.6 mA and 3.8 mA). Warning symbol 'Failure' is displayed.
F102	Signal overrange (input between 20.5 mA and 21 mA). Warning symbol 'Failure' is displayed.
F261	EEPROM error. Warning symbol 'Failure' is displayed.
F282	Parameter data not successfully saved. Warning symbol 'Failure' is displayed.
F283	Incorrect parameter data. Warning symbol 'Failure' is displayed.
F431	Calibration values incorrect. Warning symbol 'Failure' is displayed.

11.3 Spare parts

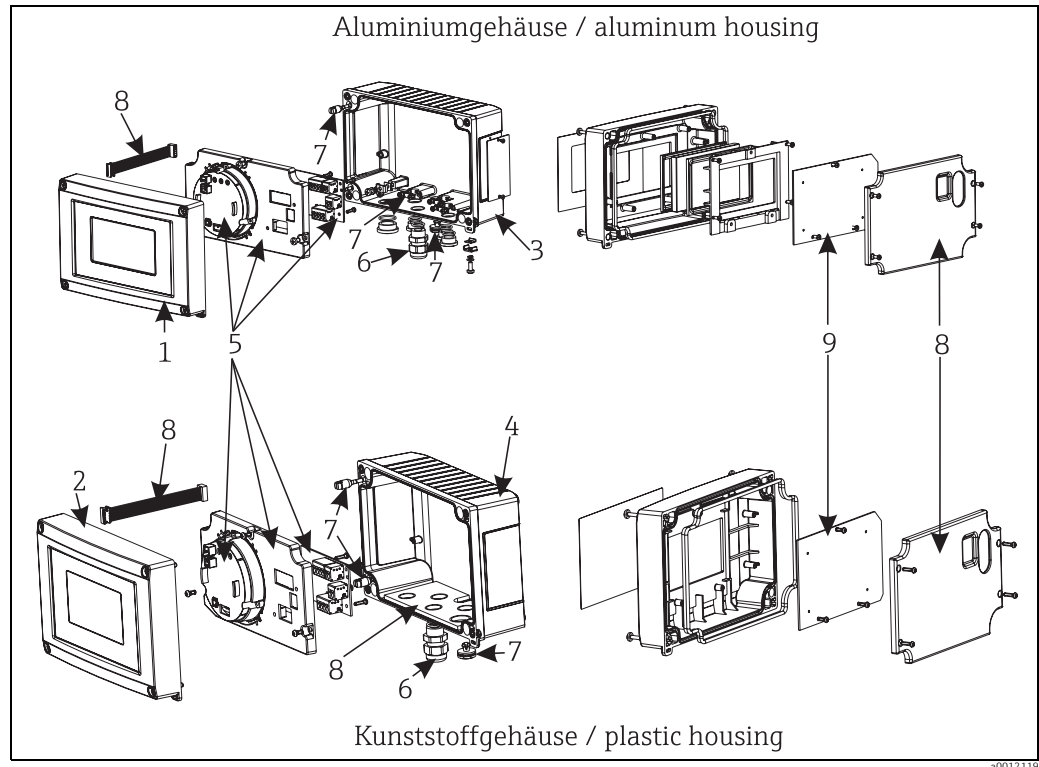

Fig. 14: Spare parts of the field indicator

Pos.-Nr.	Bestellnummer	Bezeichnung
1	RIA16X-GB	Front aluminium incl. Front foil + glass (with seals + display fixing frame)
2	RIA16X-GA	Front plastic incl. front foil
3	RIA16X-GD	Housing bottom part alu (metric threads)
	RIA16X-GE	Housing bottom part alu (NPT1/2 threads)
4	RIA16X-GC	Housing bottom part plastic (lasered)
5, 9	RIA16X-EA	Electronic complete (Ex + nonEx) incl. connection board + cover
	RIA16X-DA	LC-Display + display board
6	51004048	Cable gland M16x1.5 PA RAL7035
	51006845	Cable gland NPT 1/2, D4-8.5, IP68
	71085029	Adapter M16x1.5 NPT1/2 inside
7	RIA16X-GG	Kit small parts: Goretex filter, 2x hinge bolts, cable shield ground clamp (metal set = 5 x bracket + bolt / washers)
8	RIA16X-GF	Spare parts kit cover + connection parts (cover plate for front part, counter plate for cable glands plastic housing) ribbon cable main board -> display board

11.4 Return

To reuse later or in case of repair, the device must be packed in protective packaging, preferably the original packaging. Repairs must only be carried out by your supplier's service organisation or specially trained personnel. Enclose a note describing the fault when sending the unit in for repair.

11.5 Disposal

The device contains electronic components and must, therefore, be disposed of as electronic waste in the event of disposal. Please observe in particular the local waste disposal regulations of your country.

12 Technical data

12.0.1 Input

Measured variable

Current

Measuring range

4 to 20 mA (reverse polarity protection)

Input

- Line voltage drop < 4 V at 3 - 22 mA
- Max. line voltage drop < 6 V at max. short-circuit current 200 mA

12.0.2 Output

Output

Digital limit switch

Passive, open collector:

$I_{\max} = 200 \text{ mA}$

$U_{\max} = 35 \text{ V}$

$U_{\text{low/max}} = < 2 \text{ V at } 200 \text{ mA}$

Max. reaction time to limit value = 250 ms

Signal on alarm

- No measured value visible on the LC display, no background illumination.
- Open Collector inactive.

Transmission behavior

The indicator allows the HART[®] transmission protocol to pass unimpeded.

12.0.3 Power supply

Supply voltage

Supply by means of the 4 to 20 mA current loop.

Cable entry

The following cable entries are available:

- 2x thread NPT1/2
- 2x thread M16



The plastic housing provides up to 5 cable entries. Ex works, 3 of them remain closed. You can open the cable entries using a suitable tool.

The aluminum housing also provides 5 cable entries, 3 of which are closed with blind plugs.

12.0.4 Performance characteristics

Reference operating conditions

T= 25 °C (77 °F)

Maximum measured error

< 0.1% of scaled display range

Influence of ambient temperature (temperature drift)

Effect on the accuracy when ambient temperature changes by 1 K (1.8 °F): 0.01%

12.0.5 Installation

Installation instructions

Mounting location

Wall or pipe mounting (see 'Accessories')

Orientation

No restrictions, the orientation is determined by the readability of the display.

12.0.6 Environment

Ambient temperature limits

-40 to +80 °C (-40 to +176 °F)

-20 to +80 °C (-4 to +176 °F) when the Open Collector output is used



The display can react slowly for temperatures < -20 °C (< -4 °F).

Readability of the display cannot be guaranteed at temperatures < -30 °C (-22 °F).

Storage temperature

-40 to +80 °C (-40 to +176 °F)

Electrical safety

As per IEC 61010-1,

UL61010-1,

CSA C22.2 No. 1010.1-92

Climate class

As per IEC 60 654-1, Class C

Degree of protection

IP 67, NEMA 4X (not evaluated by UL)

Shock and vibration resistance

3g / 2 to 150 Hz as per IEC 60 068-2-6

Condensation

Permitted

Installation category

1 to IEC 61010

Pollution degree

2 to IEC 61010

Electromagnetic compatibility (EMC)

- EN 61326 (IEC 61326):
Electromagnetic compatibility (EMC requirements)
- NAMUR (NE21):
Association for Standards for Control and Regulation in the Chemical Industry
- Maximum deviation: < 0.2 % of span

12.0.7 Mechanical construction

Design, dimensions

Fiber-glass reinforced plastic housing for general purpose or, as an option, aluminum housing

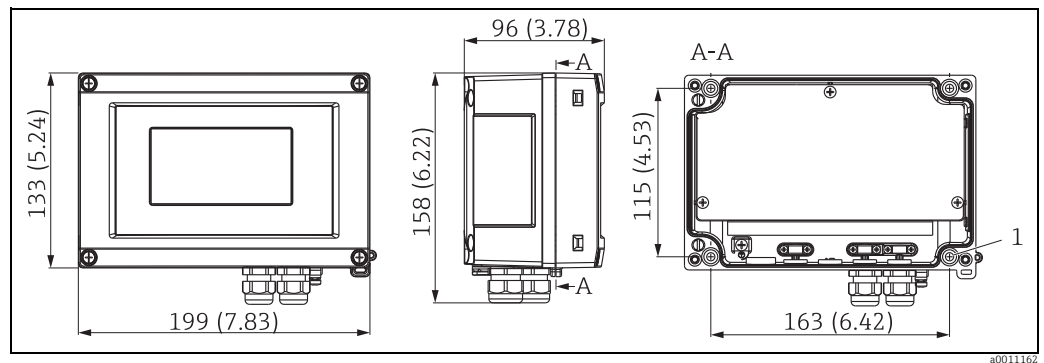

Fig. 15: Dimensions in mm (in)

Weight

- Approx. 500 g (1.1 lb) (plastic housing)
- Approx. 1.7 kg (3.75 lb) (aluminum housing)

Material

Housing	Nameplate
Fiber-glass reinforced plastic PBT-GF30	Laser marking
Aluminum AlSi12 (as an option)	Laser-writable foil, polyester

Terminals

Cables / wires up to max. 2.5 mm² (14 AWG) plus ferrule

12.0.8 Human interface

Display elements

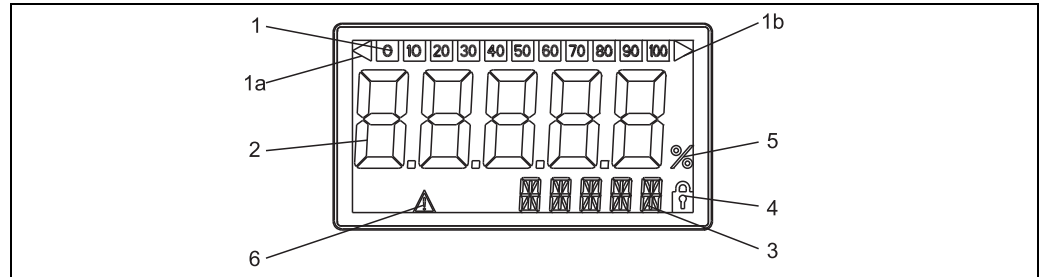

Fig. 16: LC display of the field indicator

- Item 1: bargraph display in increments of 10% with indicators for measuring range undershoot (item 1a)/overshoot (item 1b)
- Item 2: measured value display, character height 26 mm (1.02")
- Item 3: 14-segment display for units and information messages
- Item 4: symbol "programming disabled"
- Item 5: unit "%"
- Item 6: warning symbol "failure"

- Display range
-19999 to +99999
- Offset
-19999 to +99999
- Signalling
Measuring range overshoot/undershoot
- Limit value violation
Lower/upper limit value exceeded

Operating elements

3-key operation (-/+/E) integrated in device, access with housing open

Remote operation

Configuration

The device is configured with the FieldCare PC operating software. FieldCare Device Setup forms part of the scope of supply of Commubox FXA291 or TXU10-AC (see 'Accessories') or can be downloaded free of charge from the Internet at www.endress.com.

Interface

Configuration interface at device; connection to PC via configuration cable (see "Accessories").

Configurable device parameters (selection)

Measuring dimension, measuring ranges (linear/square), setup block using user code, failsafe mode, digital filter (damping), offset, limit value (min/max/alarm), alarm limit values freely adjustable.

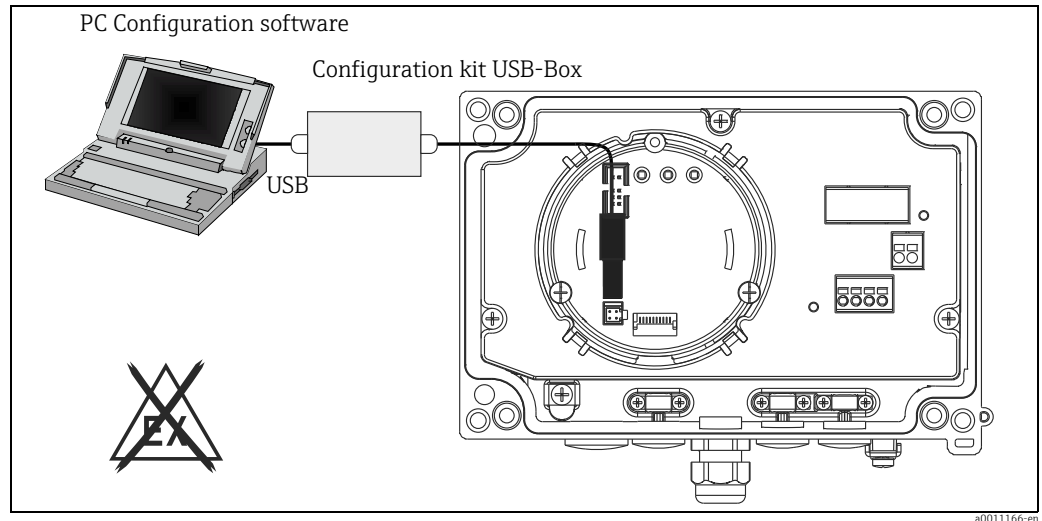

Fig. 17: Configuration with PC operating software.

12.0.9 Certificates and approvals

CE mark

The device complies with the legal requirements of the EC directives. Endress+Hauser confirms that the device has been successfully tested by affixing to it the CE mark.

Hazardous area approvals

Information about currently available Ex versions (ATEX, FM, CSA, etc.) can be supplied by your E+H Sales Center on request. All explosion protection data are given in a separate documentation which is available upon request.

Other standards and guidelines

- IEC 60529: Degree of protection by housing (IP-Code)
- IEC 61010-1: Safety requirements for electrical measurement, control and laboratory instrumentation.
- EN 61326: Electrical equipment for measurement, control and laboratory use - EMC requirements.
- NAMUR: User association of automation technology in process industries (www.namur.de)
- NEMA: Standardization association for the electrical industry in North America.

Marine approval

Germanischer Lloyd (GL)

UL

Recognized component to UL 3111-1

CSA GP

CSA General Purpose

12.0.10 Documentation

Documentation

- Overview brochure: System components: FA00016K/09
- Supplementary Ex documentation:
ATEX II2(1)G EX ib[ia] IIC T6/T5/T4: XA088R/09/a3
- Technical Information Field indicator RIA16: TI00144R/09

Index

A

ALARM 19

C

CODE 19

Configuration via interface 16

D

DAMP 17

DELY 19

DI DP 17

DI HI 17

DI LO 17

DISPL menu

 Editable unit 18

 Units 18

Display 13

Display symbols 13

DTEXT 18

E

Error code 23

F

FieldCare Device Setup 16

FWVER 20

H

Hazardous area 4

HYST 19

I

INPUT menu

 Damping 17

 Input range 17

 Measured value scaling 17

L

LIMIT menu

 Hysteresis 19

 Operating mode 19

 Response delay 19

 Switching threshold 19

LINAR 17

M

MAX 19

Menu

 DISPL 18

 INPUT 17

 LIMIT 19

 PARAM 19

 SERV 21

MIN 19

Mounting

 Wall 8

N

Nameplate 6

NAMUR 20

Navigation 14

O

OFF 19

OFFST 17

Operating functions 17

Operating keys 13–14

P

PARAM menu

 Alarm limits 20

 Locking 19

 Program information 20

 User code 19

PNAME 20

Programming in the operating matrix 14

PRSET 21

S

SERV menu

 Reset 21

SETP 19

SQRT 17

T

Terminal assignment 11

TEST 20

TEXT 18

W

Wall mounting 8

www.addresses.endress.com
