

Operating Instructions

Nivotester FTL325P, single-channel

Vibronic

Level detector with PFM input and intrinsically safe signal circuit for connecting to Liquiphant and Soliphant sensors



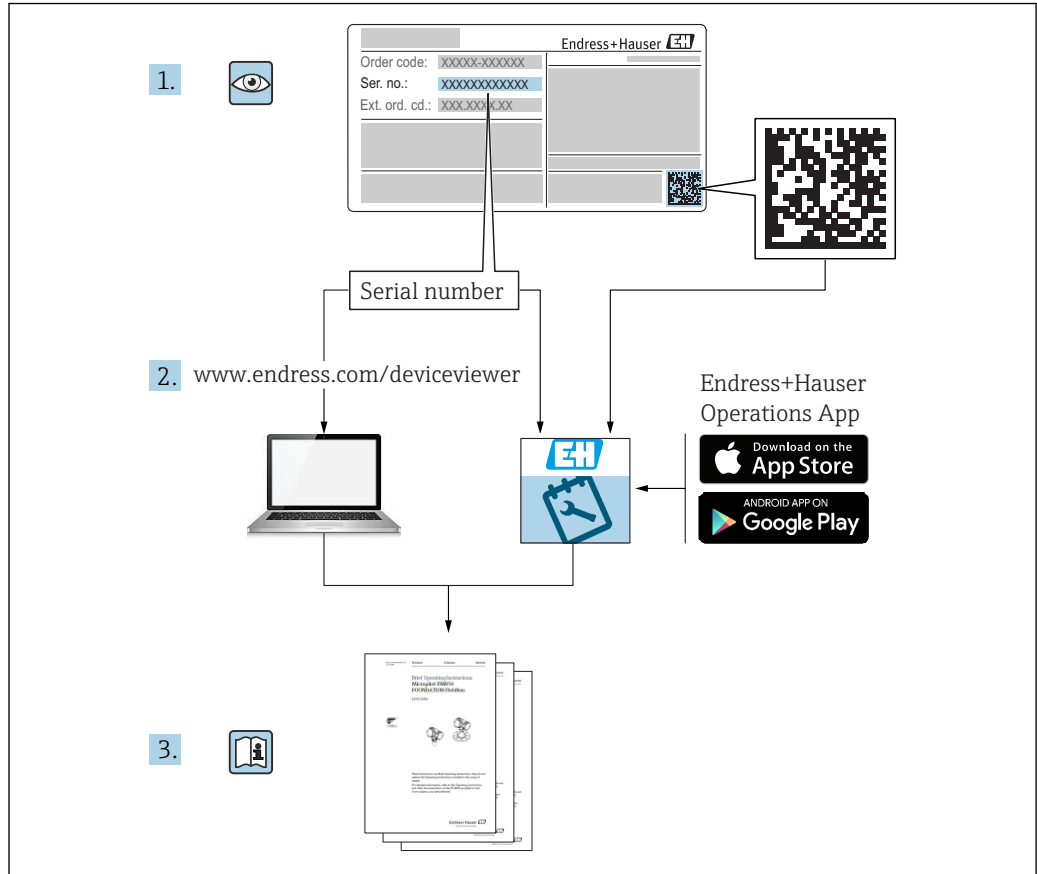

A0023555

Table of contents

1	About this document	4	11	Repair	23
1.1	Document function	4	11.1	General information	23
1.2	Symbols	4	11.2	Spare parts	23
1.3	Supplementary documentation	5	11.3	Return	23
			11.4	Disposal	24
2	Basic safety instructions	6	12	Accessories	24
2.1	Requirements for the personnel	6	12.1	Protective housing, protection class IP66	24
2.2	Designated use	6			
2.3	Workplace safety	6	13	Technical data	25
2.4	Operational safety	6	13.1	Supply voltage	25
2.5	Product safety	7	13.2	Power consumption	25
2.6	IT security	7	13.3	Output signal	25
			13.4	Ambient temperature range	25
3	Product design	7	Index		26
4	Incoming acceptance and product identification	8			
4.1	Incoming acceptance	8			
4.2	Product identification	8			
4.3	Storage, transport	9			
5	Installation	10			
5.1	Mounting conditions	10			
5.2	Mounting the measuring device	10			
5.3	Post-installation check	12			
6	Electrical connection	13			
6.1	Connection conditions	13			
6.2	Connecting the measuring device	13			
6.3	Special connection instructions	15			
6.4	Ensuring the degree of protection	15			
6.5	Post-connection check	15			
7	Operation options	16			
7.1	Operation concept	16			
7.2	Opening the front panel	16			
7.3	Display elements	16			
7.4	Operating elements	17			
8	Commissioning	18			
8.1	Function check	18			
8.2	Setting the functions	18			
8.3	Function testing of measuring system	21			
9	Diagnostics and troubleshooting ...	22			
10	Maintenance	22			
10.1	Maintenance schedule	22			

1 About this document

1.1 Document function

These Operating Instructions provide all of the information that is required in the various phases of the life cycle of the device.

1.2 Symbols

1.2.1 Safety symbols

DANGER

This symbol alerts you to a dangerous situation. Failure to avoid this situation will result in serious or fatal injury.

WARNING

This symbol alerts you to a dangerous situation. Failure to avoid this situation can result in serious or fatal injury.

CAUTION

This symbol alerts you to a dangerous situation. Failure to avoid this situation can result in minor or medium injury.

NOTICE

This symbol contains information on procedures and other facts which do not result in personal injury.

1.2.2 Electrical symbols

 Ground connection

Grounded clamp, which is grounded via a grounding system.

 Protective earth (PE)

Ground terminals, which must be grounded prior to establishing any other connections. The ground terminals are located on the inside and outside of the device.

 Output

 Input

 Fault

 No fault

 Limit signal

Light emitting diodes (LED)

 LED not lit

 LED lit

 LED flashing

1.2.3 Symbols for certain types of information and graphics

 Tip

Indicates additional information

 Reference to documentation

 Reference to another section

- 1, 2, 3 Series of steps
- ↳ Result of an individual step
- 1, 2, 3 ... Item numbers
- A, B, C ... View
- ⚠ Hazardous area
- ⊗ Safe area (non-hazardous area)

1.3 Supplementary documentation

 For an overview of the scope of the associated Technical Documentation, refer to the following:

- *W@M Device Viewer* (www.endress.com/deviceviewer): Enter the serial number from nameplate
- *Endress+Hauser Operations app*: Enter serial number from nameplate.

1.3.1 Standard documentation

Technical Information (TI)

Planning aid—contains technical data for planning and ordering information.

Operating Instructions (BA)

Installation and initial commissioning—contains all functions in the operating menu that are required for a typical measuring task. Functions beyond this scope are not included.

Brief Operating Instructions (KA)

Quick guide to obtaining the first measured value—includes all essential information from incoming acceptance to electrical connection.

1.3.2 Supplementary device-dependent documentation

Depending on the device version ordered, additional documentation or documents are provided. Always comply strictly with the instructions in the relevant additional documentation. The supplementary documentation is an integral part of the device documentation.

The relevant safety instructions are included with all certified device versions. If using the device in a hazardous area, all the specifications contained in the safety instructions must be complied with.

- Examples: ATEX, NEPSI, INMETRO, control or installations drawings for FM-, CSA- and TIIS-certified device versions
- Functional safety manual (SIL)

2 Basic safety instructions

2.1 Requirements for the personnel

The personnel must fulfill the following requirements to carry out their tasks, e. g. commissioning and maintenance:

- ▶ Trained specialists must have a qualification that is relevant to the specific function and task.
- ▶ Must be authorized by the plant owner/operator.
- ▶ Must be familiar with national regulations.
- ▶ Must have read and understood the instructions in the manual and supplementary documentation.
- ▶ Personnel must follow instructions and comply with general policies.

2.2 Designated use

- Use only as a transmitter supply unit
- Use only for point level switches from Endress+Hauser with two-wire-PFM signal
- Use only tools that have been insulated against ground
- Use only original parts

2.2.1 Incorrect use

The manufacturer is not liable for damage caused by improper or non-designated use.

Deviating application conditions may affect the level of protection. The correct functioning of the device cannot be guaranteed.

2.3 Workplace safety

For work on and with the device:

- ▶ Wear the required protective equipment according to federal/national regulations.

2.4 Operational safety

Risk of injury!

- ▶ Operate the device only if it is in proper technical condition, free from errors and faults.
- ▶ The operator is responsible for ensuring failure-free operation of the device.

Modifications to the device

Unauthorized modifications to the device are not permitted and can lead to unforeseeable dangers.

- ▶ If, despite this, modifications are required, consult with Endress+Hauser.

Repair

To ensure continued operational safety and reliability:

- ▶ Only perform repair work on the device if this is expressly permitted.
- ▶ Observe federal/national regulations pertaining to the repair of an electrical device.
- ▶ Use original spare parts and accessories from Endress+Hauser only.

2.5 Product safety

This device has been constructed and tested to state-of-the-art operational safety standards and in accordance with good engineering practice. The device left the factory in a safe operating condition.

2.5.1 CE mark

The device meets the legal requirements of the applicable EU Directives. These are listed in the corresponding EU Declaration of Conformity along with the standards applied. Endress+Hauser confirms successful testing of the device by affixing to it the CE mark.

2.5.2 EAC conformity

The device meets the legal requirements of the applicable EAC Directives. These are listed in the corresponding EAC Declaration of Conformity along with the standards applied. Endress+Hauser confirms successful testing of the device by affixing to it the EAC mark.

2.6 IT security

Provide additional protection for the device and data transfer to/from the device

- ▶ IT security measures defined in the plant owner/operator's own security policy must be implemented by plant owners/operators themselves.

3 Product design

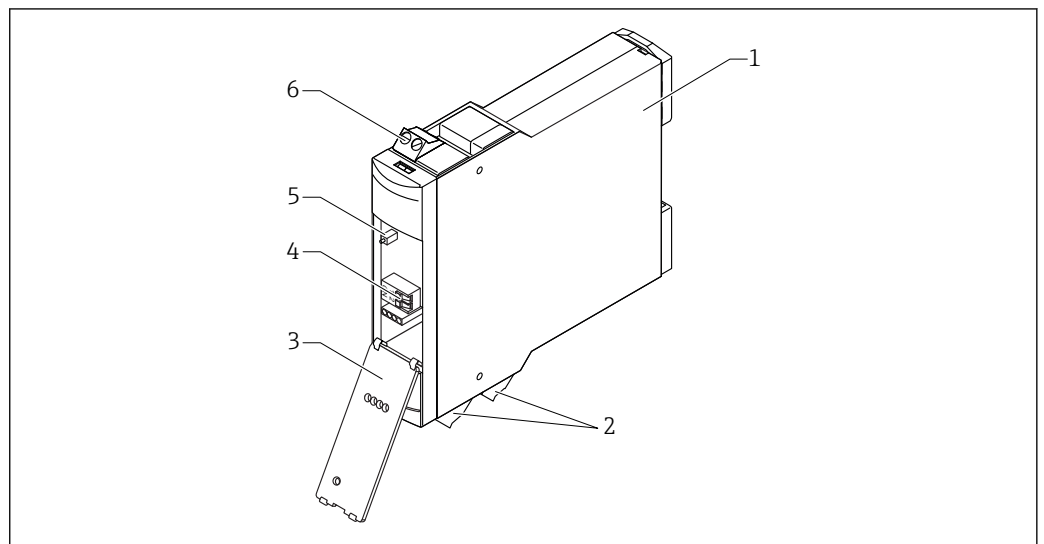

A0039126

1 Product design

- 1 Housing
- 2 External terminals
- 3 Front panel can be folded down
- 4 Internal terminals
- 5 Test button, can also be operated from the outside
- 6 External terminals

4 Incoming acceptance and product identification

4.1 Incoming acceptance

Check the following during goods acceptance:

- Are the order codes on the delivery note and the product sticker identical?
- Are the goods undamaged?
- Do the nameplate data match the ordering information on the delivery note?
- If necessary (see nameplate), are the Safety Instructions, e. g. XA, provided?

 If one of these conditions is not satisfied, contact your Sales Center.

4.2 Product identification

Nameplate data on the device

- ▶ Enter the serial number from the nameplates in the *W@M Device Viewer* (www.endress.com/deviceviewer)
 - ↳ All the information about the measuring device and all associated Technical Documentation are displayed.
- ▶ Enter the serial number from the nameplate in the *Endress+Hauser Operations app*.
 - ↳ All the information about the measuring device and all associated Technical Documentation are displayed.

4.2.1 Nameplate

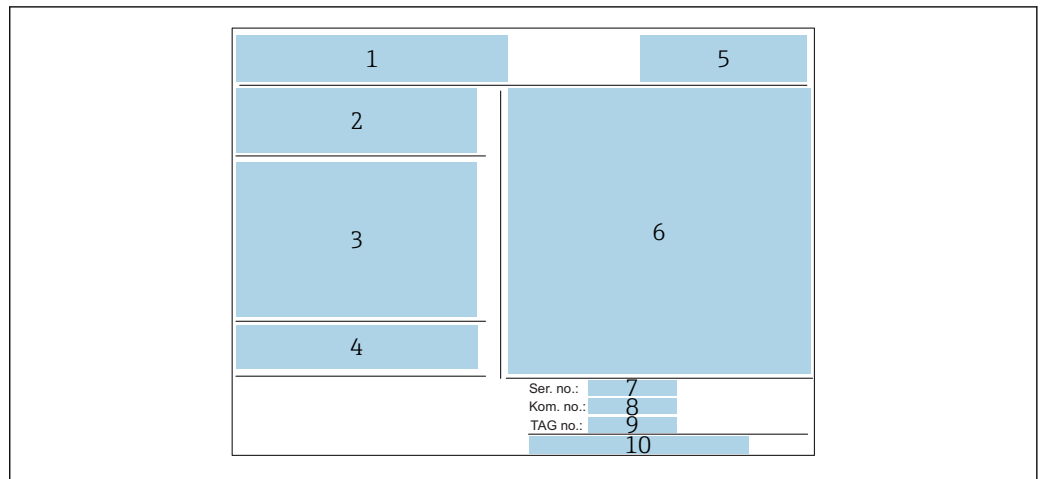

A0039180

2 Nameplate

- 1 Manufacturer's logo, product name
- 2 Supply voltage
- 3 Electrical connection
- 4 Temperature specifications and reference to additional safety-related documentation (only for certified device versions)
- 5 Reference to certifications
- 6 Identification in accordance with Directive 94/9/EC and identification of type of explosion protection (only for certified device versions)
- 7 Serial number
- 8 Kom. number
- 9 TAG number
- 10 Manufacturer's address

4.2.2 Manufacturer address

Endress+Hauser SE+Co. KG
Hauptstraße 1
79689 Maulburg, Germany

Address of the manufacturing plant: See nameplate.

4.3 Storage, transport

- Pack the device so that it is protected against impact
The original packaging offers the best protection
- Permitted storage temperature: -20 to +85 °C (-4 to +185 °F)

4.3.1 Transporting the product to the measuring point

Transport the measuring device to the measuring point in the original packaging.

5 Installation

5.1 Mounting conditions

- If using outside the hazardous area, mount the device in a cabinet.
- Mount the device so that it is protected against weather and impact.
If operating outdoors and in warmer climates, avoid direct sunlight.
Protective housing (IP65) is available for up to four single-channel Nivotester devices or two 3-channel Nivotester devices.

5.2 Mounting the measuring device

5.2.1 Horizontal orientation

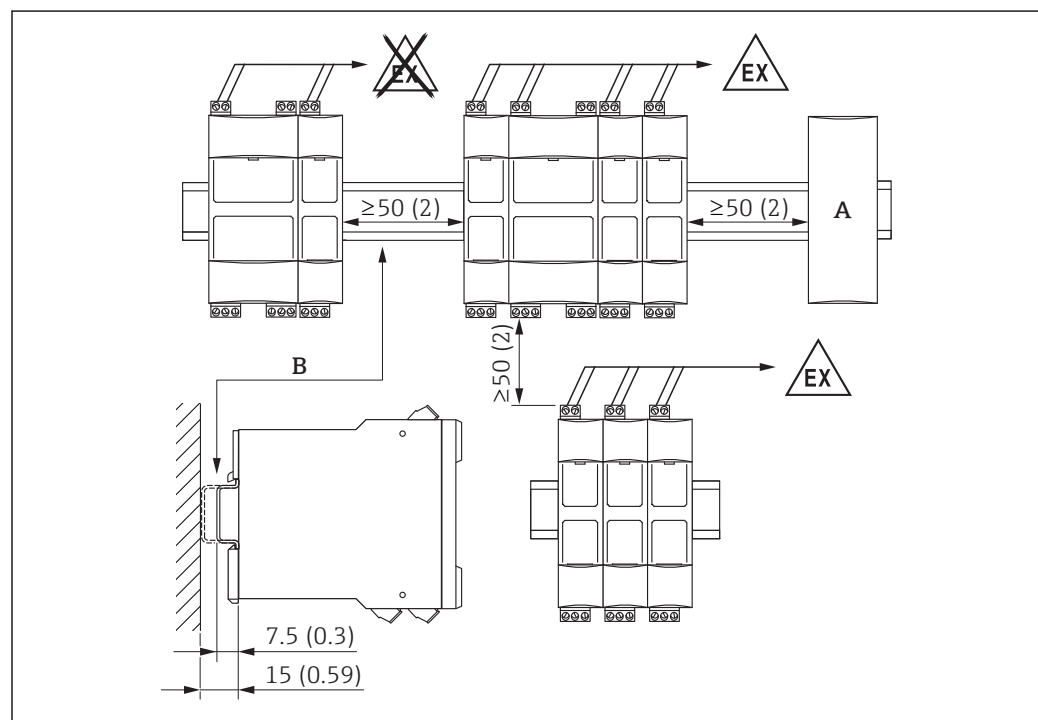

 3 Minimum spacing, horizontal orientation. Unit of measurement mm (in)

A Connection of another device type

B DIN rail in accordance with EN 60715 TH35-7.5/15

 A horizontal installation ensures better dissipation of heat than a vertical orientation.

5.2.2 Vertical orientation

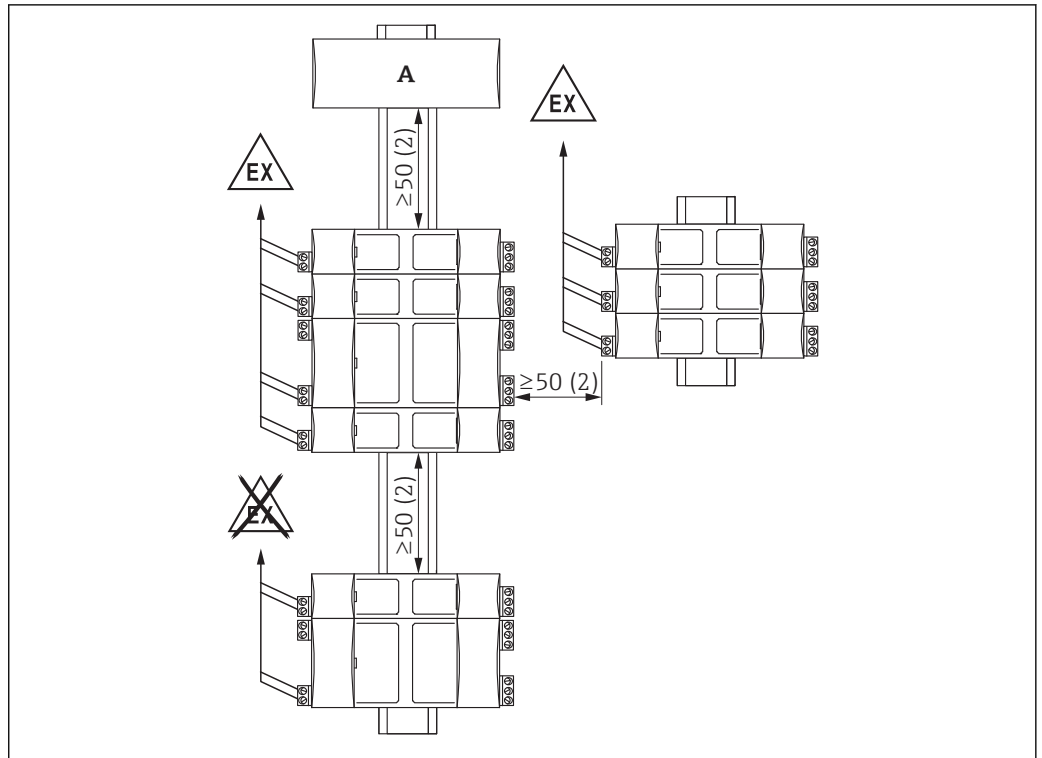

A0026420

4 Minimum spacing, vertical orientation. Unit of measurement mm (in)

A Connection of another device type

5.2.3 Mounting the device

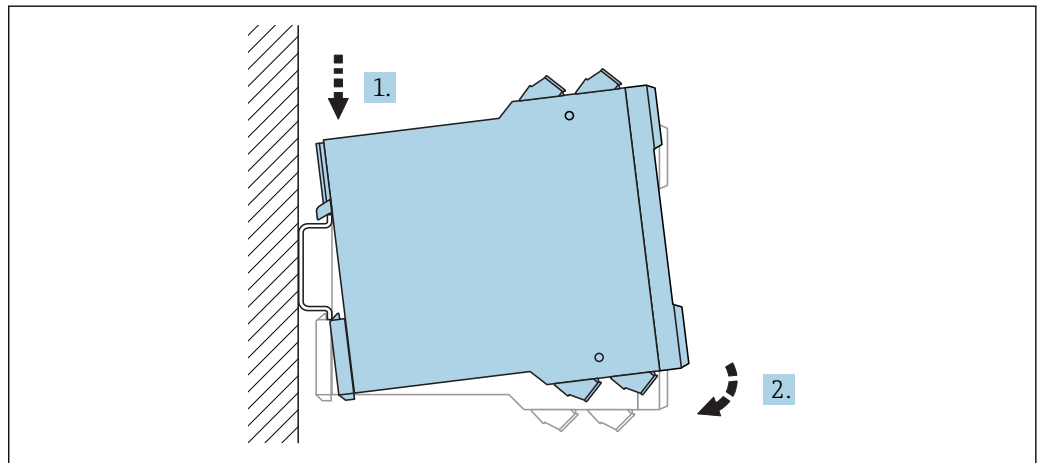

A0039139

5 Mounting; DIN rail as per EN 60715 TH35-7.5/EN 60715 TH35-15

5.2.4 Removing the device

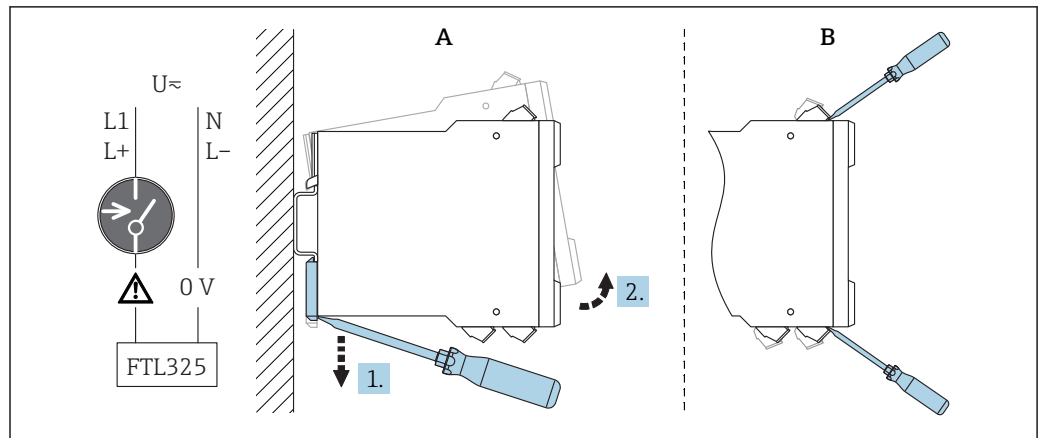

A0039140

6 Removing

A Remove from DIN rail.

B For quick replacement of devices without a cable, remove the terminal strips.

5.3 Post-installation check

- Is the measuring device undamaged (visual inspection)?
- Does the measuring device conform to the measuring point specifications?

For example:

- Supply voltage
- Ambient temperature range

- Are the measuring point number and labeling correct (visual inspection)?
- Is the measuring device adequately protected against precipitation and direct sunlight?

6 Electrical connection

6.1 Connection conditions

⚠ WARNING

Risk of explosion due to faulty connection.

- ▶ Observe applicable national standards.
- ▶ Comply with the specifications in the Safety Instructions (XA).
- ▶ Check to ensure that the power supply matches the information on the nameplate.
- ▶ Switch off the supply voltage before connecting.
- ▶ When connecting to the public mains, install a mains switch for the device such that it is within easy reach of the device. Mark the power switch as a disconnecter for the device (IEC/EN61010).

6.2 Connecting the measuring device

i The removable terminal blocks are color-coded into intrinsically safe and non-intrinsically safe terminals. This difference helps to ensure safe wiring.

6.2.1 Arrangement of terminals

i Observe the specifications on the nameplate of the device.

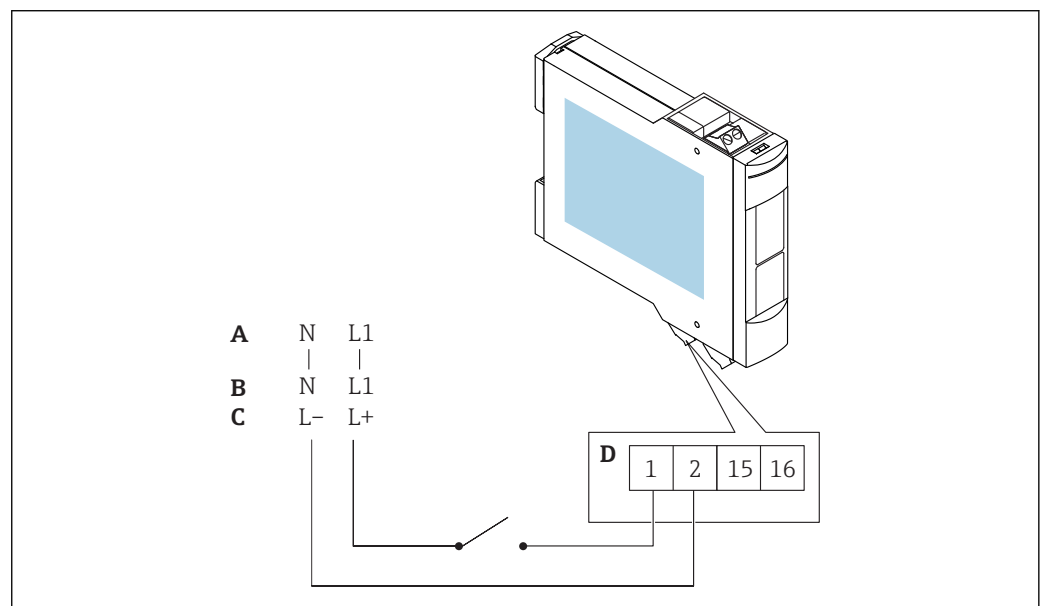

7 Arrangement of terminals

A $U \sim 85$ to $253 V_{AC}$ 50/60 Hz

B $U \sim 20$ to $30 V_{AC}$ 50/60 Hz

C $U = 20$ to $60 V_{DC}$

D Max. 1.5 mm^2 (max. AWG 16)

A0039152

6.2.2 Connecting the sensor

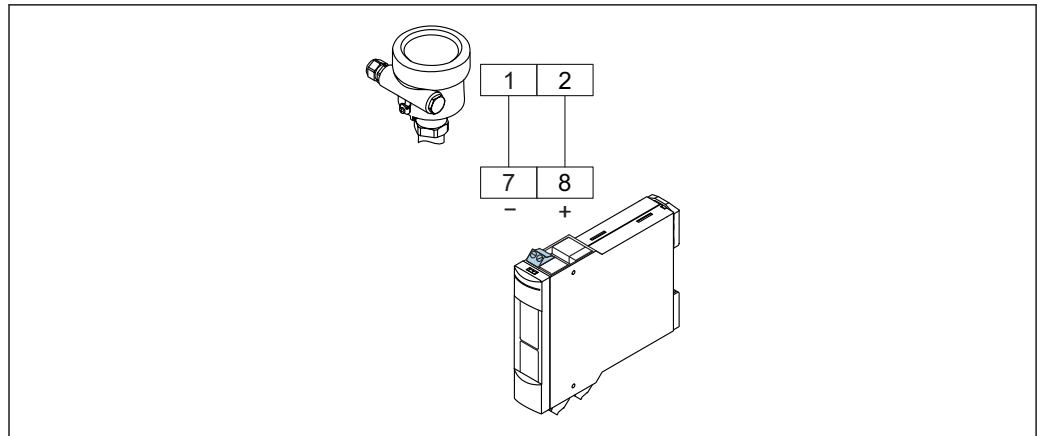

A0039154

 8 Connecting the sensor to the Nivotester

Connectable sensors:

- Liquiphant FTL51B, FTL62 and FTL64 with FEL67
- Liquiphant M FTL50(H), FTL51(H), FTL51C with FEL57
- Liquiphant S FTL70/71 with FEL57
- Soliphant M FTM50, FTM51, FTM52 with FEM57

Blue terminal blocks at top for hazardous area

- Twin-core connecting cable between the Nivotester and sensor, e. g. commercially available instrument cable or cores in a multi-core cable for measurement purposes
- Use a shielded cable in the event of increased electromagnetic interference, e. g. from machines or radio equipment.

Only connect the shield to the grounding terminal in the sensor. Do not connect it to the Nivotester.

6.2.3 Connecting the signal and control systems

Gray terminal blocks at bottom for the non-hazardous area

Relay function depending on the level and safety mode

If a device with high inductance is connected (e. g. contactor, solenoid valve), a spark arrester must be installed to protect the relay contact .

6.2.4 Connecting the supply voltage

Green terminal block at bottom

A fuse is integrated into the power supply circuit. An additional fine-wire fuse is not necessary. The Nivotester is equipped with reverse polarity protection.

6.3 Special connection instructions

6.3.1 Connecting the outputs

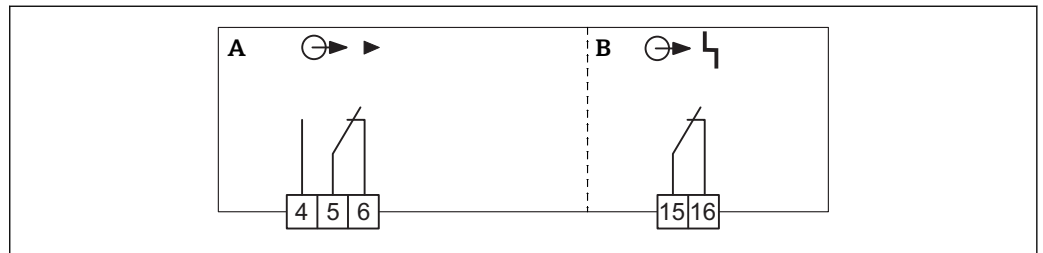

9 Connecting the outputs

A Level, limit signal

B Fault, alarm

6.4 Ensuring the degree of protection

- IP20 (as per IEC/EN 60529)
- IK06 (as per IEC/EN 62262)

6.5 Post-connection check

- Is the device or cable undamaged (visual inspection)?
- Do the mounted cables have adequate strain relief?
- Does the supply voltage match the specifications on the nameplate?
- No reverse polarity, is terminal assignment correct?
- Do the cables used comply with the requirements?
- If necessary, has a protective ground connection been established?
- If supply voltage is present, is the device operational and does a screen appear?

7 Operation options

7.1 Operation concept

Onsite configuration with DIL switches behind fold-down front panel.

7.2 Opening the front panel

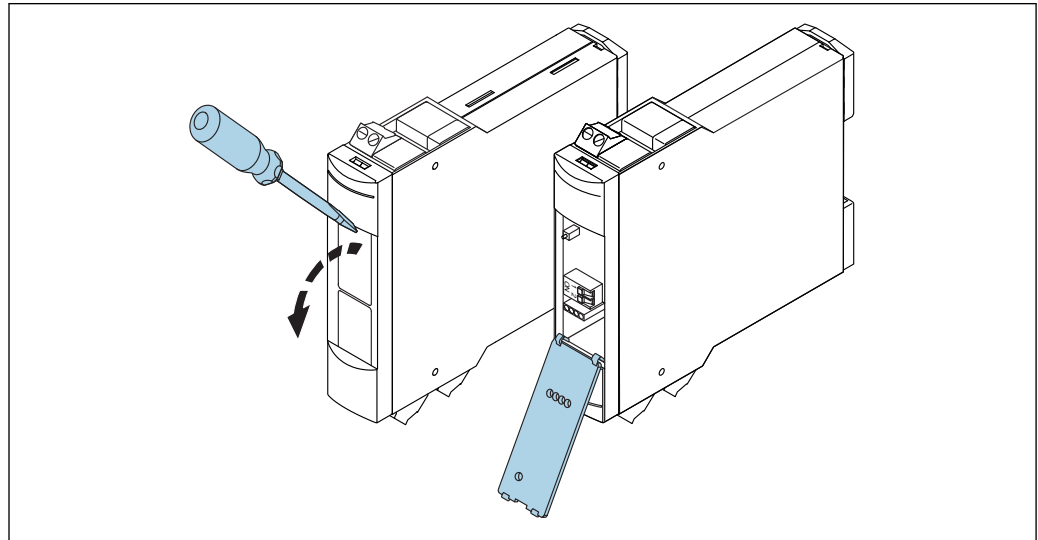

A0039236

 10 Opening the front panel

7.3 Display elements

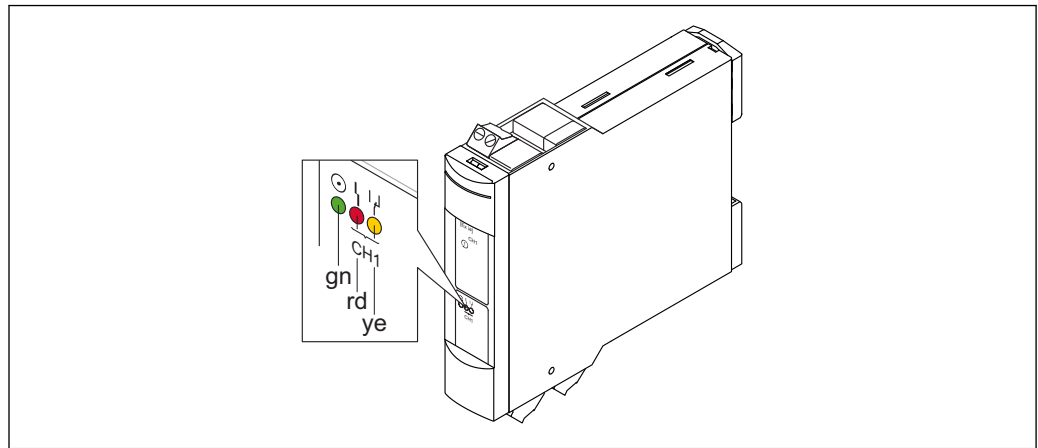

A0039238

 11 Display elements, light emitting diodes (LEDs)

- gn* Green LED: ready for operation
- rd* Red LED: fault signaling
- ye* Yellow LED: level relay energized

7.4 Operating elements

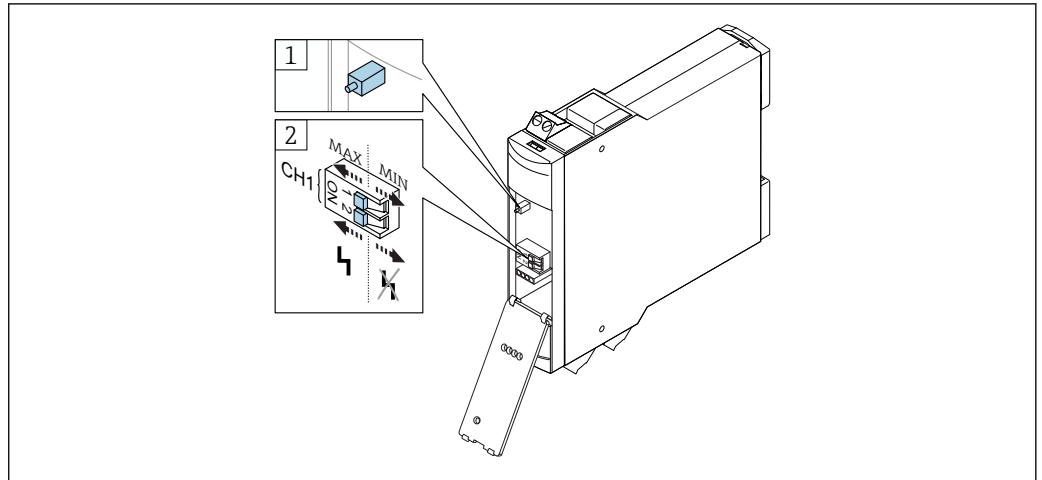

A0026315

 12 Operating elements

- 1 Test button, can also be operated when the front panel is closed
- 2 DIL switch: MAX/MIN, fault ON/OFF

8 Commissioning

8.1 Function check

- Perform installation check.
- Perform function check.

8.2 Setting the functions

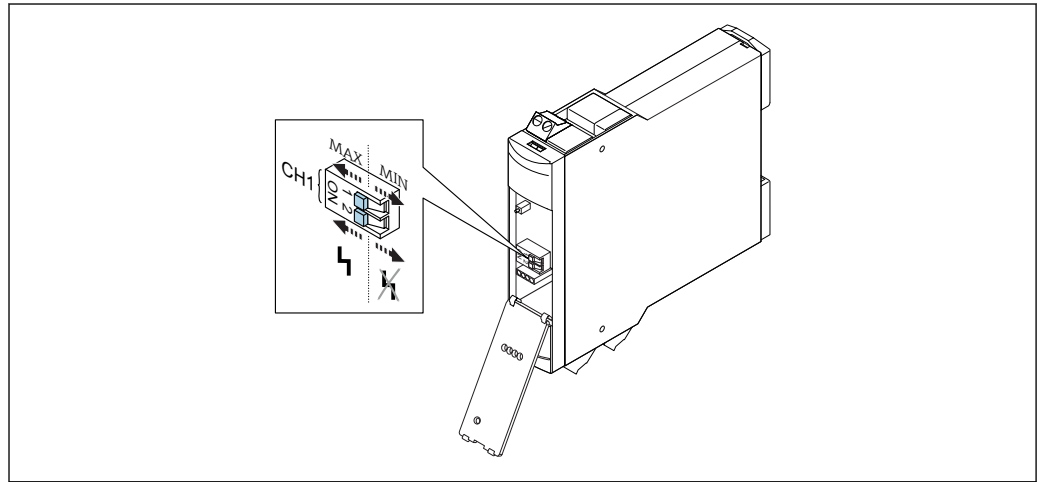

A0039260

 13 Switch for setting the functions

DIL switch CH1

- Set MAX/MIN (1)
- Set fault ON/OFF (2)

 For applications requiring functional safety in accordance with IEC 61508 (SIL), see the Functional Safety Manual. For WHG applications, see the associated WHG documents.

8.2.1 Switch position on electronic insert

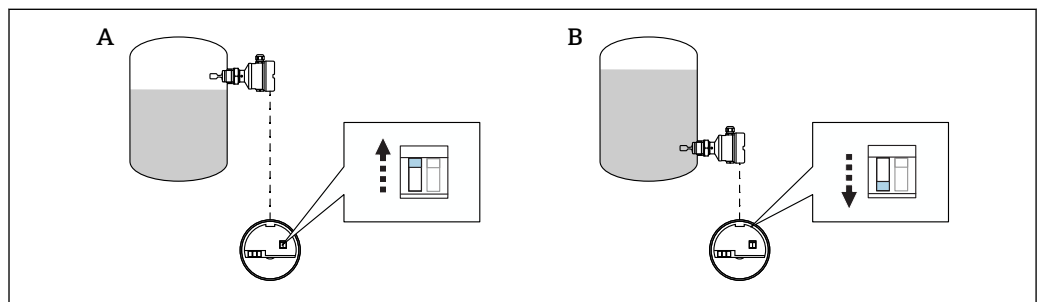

A0039743

 14 Switch position on electronic insert (FEL67)

- A MAX
- B MIN

When using the Liquiphant FTL51B, FTL62, FTL64 sensor with electronic insert FEL67, sensor (H level) FEL67 must be set to MAX safety and sensor (L level) FEL67 must be set to MIN safety.

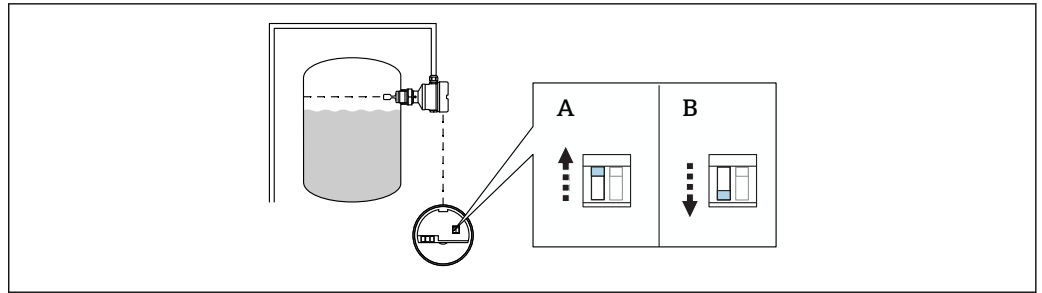

A0039561

15 Switch position on electronic insert FEL57

- A STD (standard)
- B EXT (extended)

i This setting is only relevant for the function test.

8.2.2 MAX safety mode with fault signaling

MAX				

Signal	gn	rd	ye
MAX	●	●	●
ca. 150 Hz	●	●	●
ca. 50 Hz	●	●	●
0 Hz	●	●	●
0 V	●	●	●

A0039191

16 Switching behavior and signaling

8.2.3 MAX safety mode without fault signaling

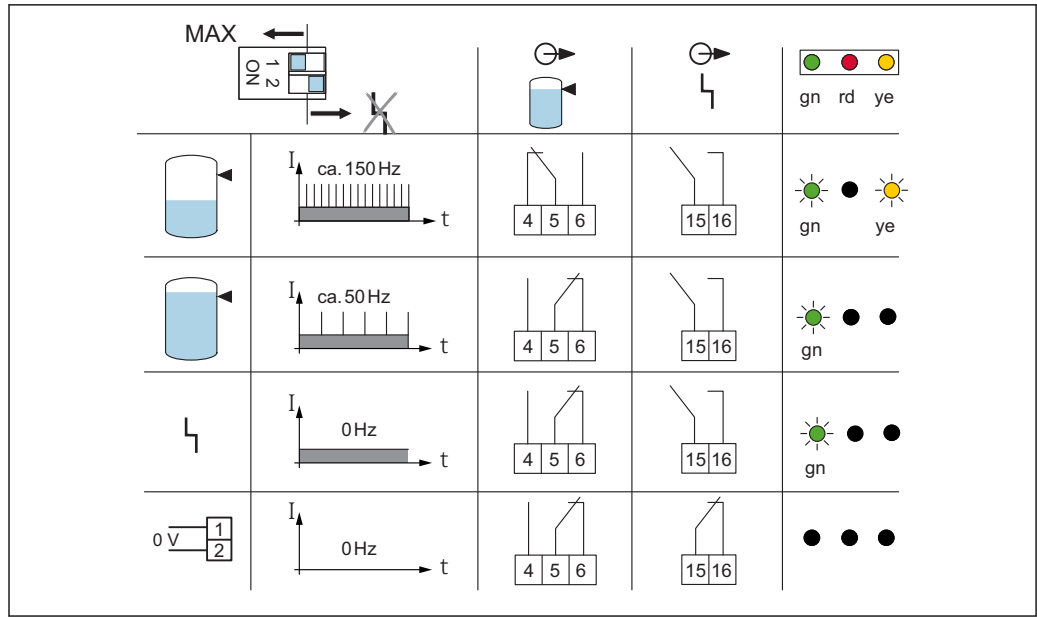

A0039192

17 Switching behavior and signaling

8.2.4 MIN safety mode with fault signaling

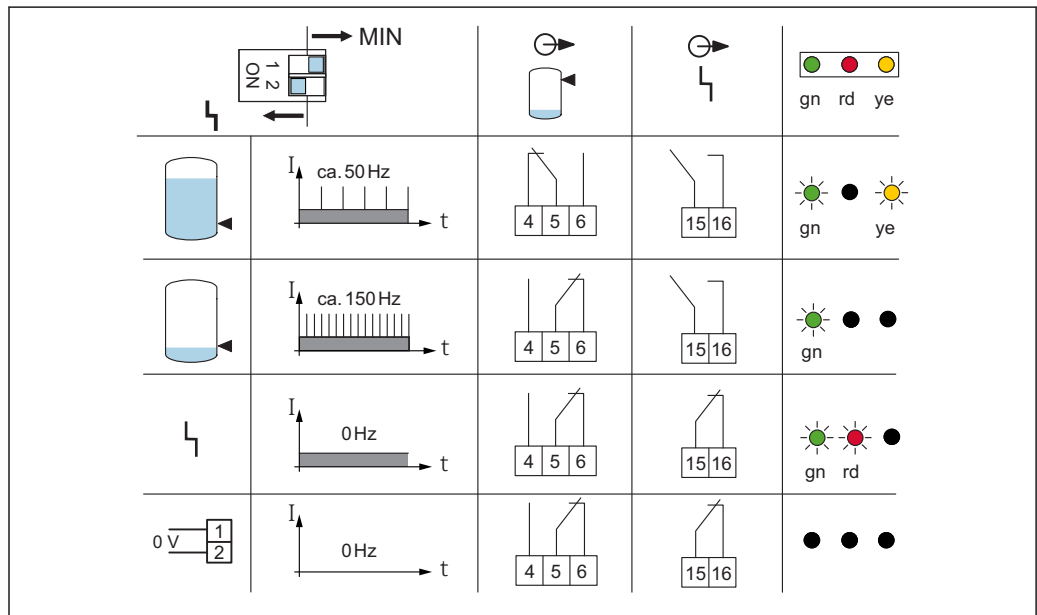

A0039193

18 Switching behavior and signaling

8.2.5 MIN safety mode without fault signaling

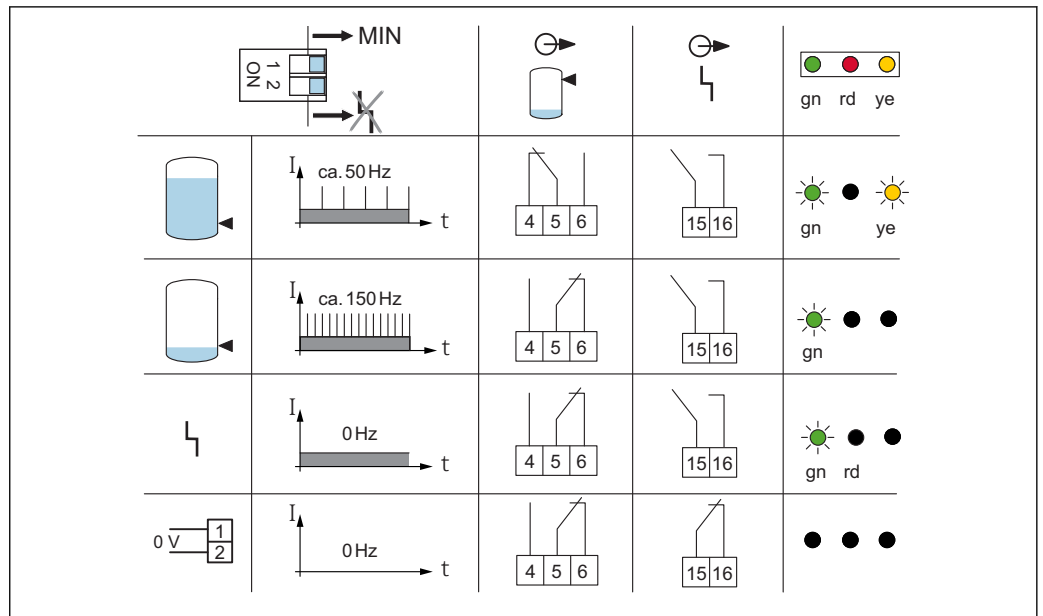

19 Switching behavior and signaling

8.3 Function testing of measuring system

Function testing of measuring system without a change in level

- Function testing of Liquiphant M/S FTL50/51/50H/51H/51C; FTL70/71 with electronic insert FEL57, see KA00147F
- Proof testing of Liquiphant FTL51B, FTL62, FTL64 with electronic insert FEL67 as per SIL and WHG (German Water Resources Act)
See the Functional Safety Manual and WHG approval

- i** The certificates, approvals and other documentation currently available can be accessed as follows:
Endress+Hauser website: www.endress.com → Downloads.
- i** In the event of a power failure, the self-test runs automatically.
Consider the impact on the function of the system. Provide a switching delay if required.

9 Diagnostics and troubleshooting

Does not switch

- Possible cause: no supply voltage present (green LED is not lit)
Corrective measure: check supply voltage
- Cause: electronics are defective
Corrective measure: replace Nivotester
- Cause: welded contacts (following a short-circuit)
Corrective measure: replace Nivotester; install fuse in contact circuit
- Cause: sensor is defective
Corrective measure: replace sensor

Switches incorrectly

Possible cause: switch on Nivotester for limit signal is incorrectly set

Corrective measure: correctly set the switch behind the front panel on the Nivotester

Continuous fault signaling

- Possible cause: short-circuit or disconnect in the signal line to the sensor
Corrective measure: check signal line
- Possible cause: sensor electronics are defective
Corrective measure: replace electronics
- Possible cause: Nivotester is defective
Corrective measure: replace Nivotester

Switches incorrectly following power failure

Possible cause: electronic insert, behavior during power-up test (proof test)

Corrective measure: observe switching behaviour at electronic insert

Block system control after power failure for approx. 45 s

10 Maintenance

10.1 Maintenance schedule

As a general rule, no specific maintenance work is required.

11 Repair

11.1 General information

11.1.1 Repair concept

Endress+Hauser repair concept

- Measuring devices have a modular design
- Customers can carry out repairs

 For more information on service and spare parts, please contact your Endress+Hauser sales representative.

11.1.2 Repair of Ex-certified devices

WARNING

Limitation of electrical safety due to incorrect connection!

Risk of explosion!

- ▶ Only specialist personnel or the Endress+Hauser service team may carry out repairs on Ex-certified devices.
- ▶ Relevant standards and national regulations on hazardous areas, safety instructions and certificates must be observed.
- ▶ Use only original Endress+Hauser spare parts.
- ▶ Please note the device designation on the nameplate. Only identical parts may be used as replacements.
- ▶ Carry out repairs according to the instructions. On completion of repair work, carry out the routine test specified for the device.
- ▶ Only the Endress+Hauser service team is permitted to modify a certified device and convert it to another certified version.
- ▶ All repairs and modifications must be documented.

11.2 Spare parts

- Some replaceable measuring device components are identified by means of a spare part nameplate. This contains information about the spare part.
- All the spare parts for the measuring device along with the order code are listed in the *W@M Device Viewer* (www.endress.com/deviceviewer) and can be ordered. If available, users can also download the associated Installation Instructions.

 Measuring device serial number or QR code:
Located on the device and spare part nameplate.

11.3 Return

The measuring device must be returned if the wrong device has been ordered or delivered. As an ISO-certified company and also due to legal regulations, Endress+Hauser is obliged to follow certain procedures when handling any returned products that have been in contact with medium. To ensure safe, swift and professional device returns, please refer to the procedure and conditions for returning devices provided on the Endress+Hauser website at <http://www.endress.com/support/return-material>

11.4 Disposal



If required by the Directive 2012/19/EU on waste electrical and electronic equipment (WEEE), our products are marked with the depicted symbol in order to minimize the disposal of WEEE as unsorted municipal waste. Such products may not be disposed of as unsorted municipal waste and can be returned to Endress+Hauser for disposal at conditions stipulated in our General Terms and Conditions or as individually agreed.

12 Accessories

12.1 Protective housing, protection class IP66

- With integrated DIN rail
- With transparent cover
- Cover can be closed and sealed
- Dimensions (in) W/H/D: 180/182/165 (7.1/7.2/6.5)
- Order number: 52010132

13 Technical data

13.1 Supply voltage

13.1.1 Alternating current version (AC)

Voltage range: 85 to 253 V_{AC}, 50/60 Hz

13.1.2 Direct current version (DC)

- Voltage range: 20 to 30 V_{AC}/ 20 to 60 V_{DC}
- D/C power supply: maximum 85 mA
- Permissible residual ripple within tolerance: U_{ss} = maximum 2 V

13.2 Power consumption

AC

Maximum 2.0 W

DC

Maximum 1.7 W (with U_{min} 20 V)

13.3 Output signal

- Relay output per channel: 1 potential-free changeover contact for the level alarm
- 1 fault-signaling relay for channel 1 (one potential-free changeover contact, but it is only possible to connect to two contacts)
- Switching delay: approx. 0.5 s
- Operating life: at least 10⁵ switching operations with maximum contact load
- Relay contact switching capacity:

Alternating voltage (AC)

U ~ maximum 250 V

I ~ maximum 2 A

P ~ maximum 500 VA with cos φ ≥ 0.7

Direct current (DC)

U = maximum 40 V

I = maximum 2 A

P = maximum 80 W

13.4 Ambient temperature range

- For single installation: -20 to +60 °C (-4 to 140 °F)
- For side-by-side installation without lateral spacing: -20 to +50 °C (-4 to +122 °F)
- For installation in protective housing: -20 to +40 °C (-4 to +104 °F)
A maximum of four single-channel Nivotester devices or a maximum of two 3-channel Nivotester devices or a maximum of two single-channel Nivotester devices plus one 3-channel Nivotester device may be installed.
- Storage temperature: -20 to +85 °C (-4 to 185), preferably at 20 °C (68 °F)

Index

A

About this document 4

C

CE mark 7

Commissioning 18

Connection conditions 13

D

Designated use 6

Disposal 24

Document

Function

Symbols 4

E

EAC conformity 7

Electrical connection 13

Electrical symbols 4

F

Function check 18

I

Incoming acceptance 8

Installation

Installation 10

N

Nameplate 9

O

Operation 16

Operation options 16

Operational safety 6

P

Post-connection check 15

Post-installation check 12, 18

Product identification 8

Product safety 7

R

Repair concept 23

Requirements for the personnel 6

Return 23

S

Safety instructions 6

Safety symbols 4

Spare parts 23

Nameplate 23

Storage, transport 9

Supplementary documentation

Supplementary documentation 5

Symbols 4

T

Types of information 4

W

W@M Device Viewer 23

Workplace safety 6



71481673

www.addresses.endress.com
