



—  
your partner  
in sensor  
technology.

# + Datasheet EE680

**Air Velocity and Temperature  
Sensor for Laminar Flow**



# EE680

## Air Velocity and Temperature Sensor for Laminar Flow

The EE680 is dedicated for precise measurement of the standardised air velocity ( $v_n$ ) and the temperature (T) in laminar flow. The GMP-compliant design is ideal for cleanrooms and safety cabinets in pharmaceutical, life sciences and microelectronics industries.

### Outstanding Measurement Performance

The EE680 operates on the hot film anemometer principle. It employs an E+E thin-film sensing element which stands for excellent accuracy down to 0.1 m/s (20 ft/min), long term stability and low angular dependency. The multipoint air velocity factory adjustment leads to best performance over the entire working range. The E+E proprietary coating protects the sensing element against  $H_2O_2$  and corrosive cleaning agents.

### Versatility

The EE680 is available as straight and angled version with various probe lengths. The design is optimised for easy cleaning, while the mounting concept and the M12 stainless steel connector facilitate the installation and replacement. A led ring integrated in the stainless steel enclosure indicates the laminar flow conditions and the sensor status.

### Analogue Outputs or RS485 Interface, User Selectable

The  $v_n$  and T measured data is available as current or voltage analogue outputs or on the RS485 interface with Modbus RTU protocol.

### User Configurable and Adjustable

The setup and adjustment of the EE680 can be easily performed with an optional adapter and the free PCS10 Product Configuration Software.



EE680-T29 angled probe with flange



EE680-T15 straight probe with flange

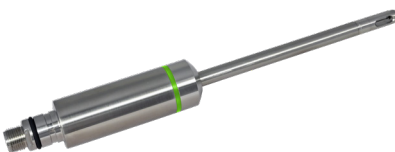

EE680-T15 straight probe without flange



EE680 mounting flange

# Features



## EE680 Sensor

- Highly accurate over the entire working range
- Precise measurement of even smallest air flow
- Combined v<sub>n</sub> and T measurement
- Voltage, current or digital RS485 output, selectable
- User configurable and adjustable

## Probe and Sensing Element

- E+E sensor coating for best resistance against H<sub>2</sub>O<sub>2</sub>
- Stainless steel probe and sensing head

## Visualization

- Optical indication of the laminar flow and sensor condition
- LED ring status directly visible on the sensor

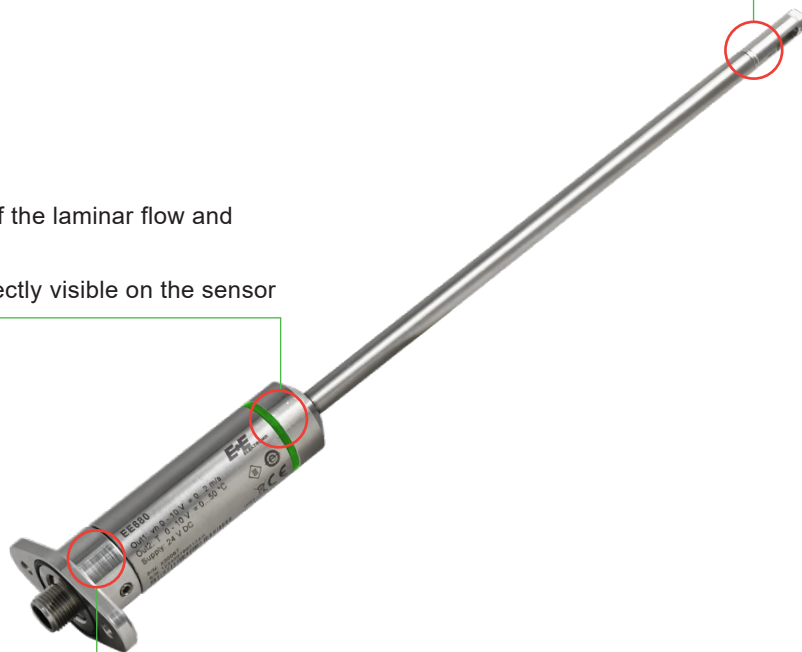

## Application Specific Design

- GMP compliant design for easy cleaning
- Straight or angled probe with various lengths
- Stainless steel mounting flange
- M12 stainless steel connector

## Inspection certificate

according to DIN EN 10204-3.1 with six v points

# Features

## E+E Sensor coating

The E+E proprietary sensor coating is a protective layer applied to the active surface of the sensing element. The coating substantially extends the life-time and the measurement performance of the E+E sensor in applications with frequent H<sub>2</sub>O<sub>2</sub> sterilization processes. Additionally, it improves the sensor's long term stability.

## E+E Modular Sensor Platform

The EE680 is compatible with the Sigma 05 host device of the E+E Modular Sensor Platform. Together they become a versatile, plug-and-play vn/T modular sensor with analogue outputs and optional display. Besides EE680, Sigma 05 accommodates also other E+E intelligent sensing probes. See [www.epluse.com/sigma05](http://www.epluse.com/sigma05) for further details.



Sigma 05 with EE680

## Accredited Traceable Calibration Certificate



Internationally recognised certificates for the calibration of measuring instruments from accredited laboratories document the traceability of the measurements to the International System of Units (SI). The E+E Elektronik calibration laboratory offers two levels of traceable calibrations.

- As a Designated Institute (DI) of the Republic of Austria, the E+E calibration laboratory maintains Austria's national measurement standards for humidity, dew point temperature, air velocity and CO<sub>2</sub>. This authorises the E+E calibration laboratory to issue calibration certificates at the level of a National Metrological Institute (NMI).
- The E+E calibration laboratory is accredited by Akkreditierung Austria in accordance with DIN EN ISO/IEC 17025 with the identification number 0608. This allows the laboratory to issue ISO 17025 certificates for the measurands humidity, temperature, dew point temperature, air velocity, flow, pressure and CO<sub>2</sub>.

Visit [www.eplusecal.com](http://www.eplusecal.com) for detailed information on calibration and to enquire a certificate of accredited traceable calibration for the EE680 from the Designated Institute.

## ISO 9001 Calibration Certificate

An ISO 9001 calibration certificate documents the comparative measurement of a device against high quality reference equipment (factory level standard). The comparison is performed in accordance with internal procedures that comply with ISO 9001 and provides information on the specimen's measuring accuracy. The reference equipment is traceable to national standards, however, the calibration process is not accredited. Therefore, an ISO 9001 calibration is neither traceable nor internationally comparable.

Visit [www.epluse.com/iso9001cal](http://www.epluse.com/iso9001cal) for detailed information on calibration and to enquire an ISO 9001 calibration certificate.

# Dimensions

Values in mm (inch)

## Type T15

Straight probe

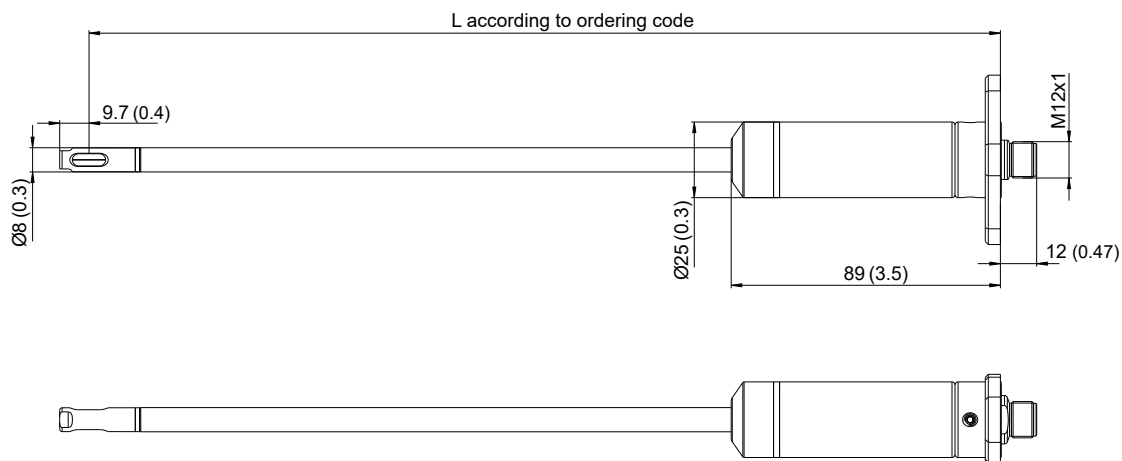

## Mounting flange

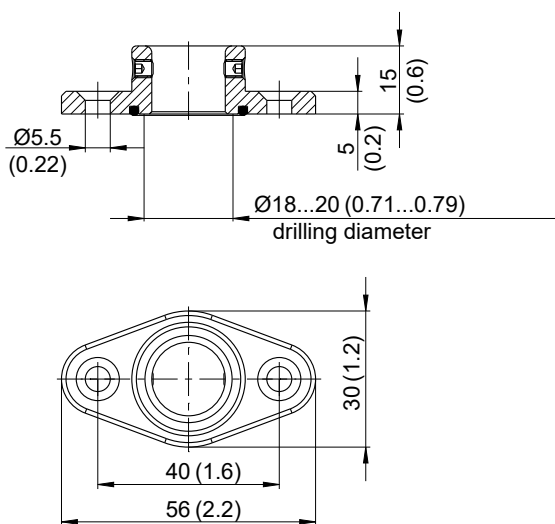

## Type T29

90° angled probe

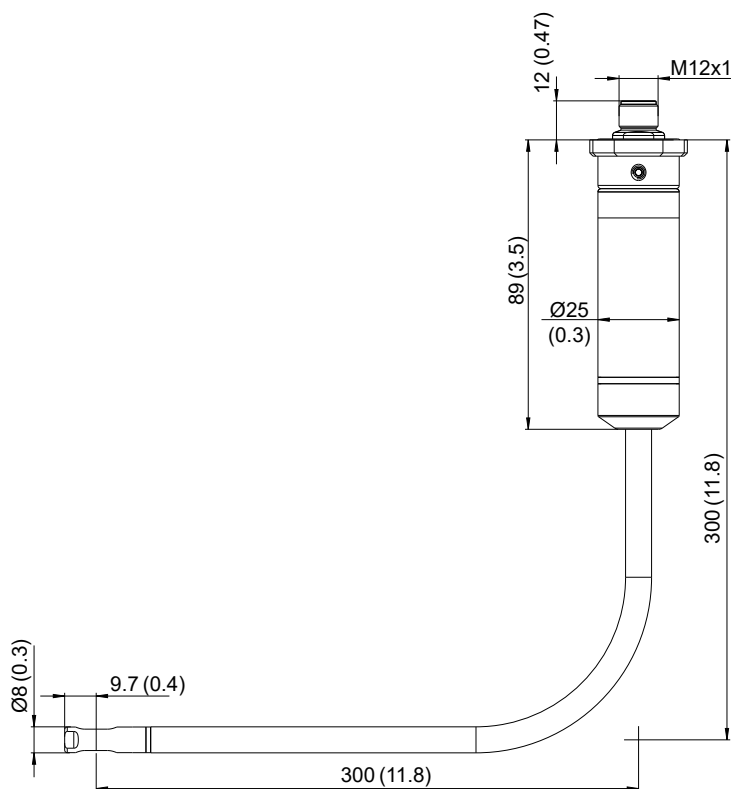

# Technical Data

## Measurands

### Air Velocity (v)

<b>Standard conditions</b> factory setting	pn = 1 013.25 mbar (14.7 psi); Tn = 23 °C (73 °F) Freely configurable via PCS10
<b>Measuring range</b>	0...2 m/s (0...400 ft/min)
<b>Accuracy</b> <sup>1)</sup> in air @ 23 °C (73 °F) and 1 013 hPa (14.7 psi)	0.1...2 m/s (20...400 ft/min): ± (0.5 % of mv +0.05 m/s) <span style="float: right;">mv = measured value</span>
<b>Dependency</b> <b>of inflow angle (α)</b> <b>of inflow direction</b>	<3 % for α < ±10° <3 %
<b>Response time</b> t <sub>90</sub> , typ.	<1.5...40 s (Factory setting: 1.5 s, configurable via PCS10)

1) The accuracy statement includes the uncertainty of the factory calibration with an enhancement factor k=2 (2-times standard deviation).  
The accuracy was calculated in accordance with EA-4/02 and with regard to GUM (Guide to the Expression of Uncertainty in Measurement).

### Temperature (T)

<b>Measuring range</b>	-20...+70 °C (-4...+158 °F)
<b>Accuracy</b> , typ. in air @ 23 °C (73 °F), at air flows ≥ 0.45 m/s	±0.5 °C (±0.9 °F)

## Outputs



### Analogue

<b>Two freely scalable outputs</b>	0 - 5 V / 0 - 10 V 0 - 20 mA (3-wire) / 4 - 20 mA (3-wire)	-1 mA < I <sub>L</sub> < 1 mA Load resistance ≤ 350 Ω
------------------------------------	---	--

### Digital

<b>Digital interface</b>	RS485 (EE680 = 1/10 unit load)
<b>Protocol</b> <b>Factory settings</b> <b>Supported Baud rates</b> <b>Measured data types</b>	Modbus RTU 9600 Baud, parity even, 1 stop bit, Modbus address 68 9600, 19200, 38400, 57600, 76800 and 115200 FLOAT32 and INT16

## General

<b>Power supply</b> class III  USA & Canada: Class 2 supply necessary	24 V DC ±20 %
<b>Current consumption</b> , typ.	<30 mA
<b>Electrical connection</b>	M12x1, 5 poles, stainless steel 1.4404
<b>Pressure working range</b>	700...1300 hPa (10.2...18.9 psi)
<b>Storage conditions</b>	-20...+70 °C (-4...+158 °F) 0...95 %RH, non-condensing
<b>Enclosure material</b>	Stainless steel 1.4404
<b>Protection rating</b>	IP65
<b>Electromagnetic compatibility</b>	EN 61326-1      EN 61326-2-3      Industrial environment FCC Part15 Class A      ICES-003 Class A
<b>Conformity</b>	 
<b>Configuration and adjustment</b>	PCS10 Product Configuration Software ( <a href="#">free download</a> ) and configuration adapter

# Ordering Guide

Feature	Description	Code				
Hardware Config.		<b>EE680-</b>				
	Type	Straight probe	T15		T15	
		90° angled probe		T29		T29
	Measuring range	0...2 m/s (0...400 ft/min)	No code			
Probe length	200 mm (7.87")	L200		L200		
	300 mm (11.81")	L300	L300	L300	L300	
Mounting	With flange	TG5				
Software-Setup (Analogue-) Outputs	Output signal <sup>1)</sup>	4 - 20 mA	GA6			
		0 - 20 mA	GA5			
		0 - 10 V	GA3			
		0 - 5 V	GA2			
		Digital interface RS485	No code			
Output 1 measurand	Standardised air velocity <sup>2)</sup> vn [m/s]	No code				
	Standardised air velocity <sup>2)</sup> vn [ft/min]	MA23				
	Temperature T [°C]	MA1				
	Temperature T [°F]	MA2				
Output 1 scaling low	0	No code				
	Value	SALValue				
Output 1 scaling high	2	No code				
	Value	SAHValue				
Output 2 measurand	Temperature T [°C]	No code				
	Temperature T [°F]	MB2				
	Standardised air velocity vn [m/s]	MB22				
	Standardised air velocity vn [ft/min]	MB23				
Output 2 scaling low	0	No code				
	Value	SBLValue				
Output 2 scaling high	50	No code				
	Value	SBHValue				
Protocol	Modbus RTU <sup>3)</sup>	P1				
Accredited Traceable Calibration Certificate in accordance with DIN EN ISO/IEC 17025		see <a href="http://www.eplusecal.com">www.eplusecal.com</a>				
ISO 9001 Calibration Certificate		see <a href="http://www.epluse.com/iso9001cal">www.epluse.com/iso9001cal</a>				

1) Applies to both outputs.

2) Standardised air velocity vn at standard conditions (factory setup): pn = 1013.25 hPa (14.7 psi), Tn = 23 °C (73 °F), settable via PCS10.

3) Factory settings: baud rate 9600, parity even, stop bits 1.

Modbus map and communication settings: See User Manual and Modbus Application Note at [www.epluse.com/ee680](http://www.epluse.com/ee680).

# Order Example

## EE680-T15L300TG5GA6

Feature	Code	Description
Type	T15	Straight probe
Measuring range	No Code	0...2 m/s (0...400 ft/min)
Probe length	L300	300 mm (11.81")
Mounting	TG5	With flange
Output signal	GA6	4 - 20 mA
Output 1 measurand	No code	Standardised air velocity $v_n$ [m/s]
Output 1 scaling low	No code	0
Output 1 scaling high	No code	2
Output 2 measurand	No code	Temperature T [°C]
Output 2 scaling low	No code	0
Output 2 scaling high	No code	50

## EE680-T29L300TG5P1

Feature	Code	Description
Type	T29	90° angled probe
Measuring range	No code	0...2 m/s (0...400 ft/min)
Probe length	L300	300 mm (11.81")
Mounting	TG5	With flange
Output signal	No code	Digital interface RS485
Protocol	P1	Modbus RTU

# Accessories

For further information see datasheet [Accessories](#).

Accessories	Code
Modbus configuration adapter	HA011018
E+E Product Configuration Software (Free Download: <a href="http://www.epluse.com/pcs10">www.epluse.com/pcs10</a> )	PCS10
Protection cap for M12 socket	HA010781
Protection cap for M12 plug	HA010782
Sensor connection cable, shielded, 5 poles, M12x1 socket ↔ wire ferrules	
1.5 m (4.9 ft)	HA010819
5 m (16.4 ft)	HA010820
10 m (32.8 ft)	HA010821
Y-Style Splitter, M12x1, 1 Plug ↔ 2 Sockets, 5 Poles	HA030204
Connector, M12x1 socket, 5 poles, for self assembly	HA010708
Mounting set	HA011601
M12 sealing plug, stainless steel	HA011602

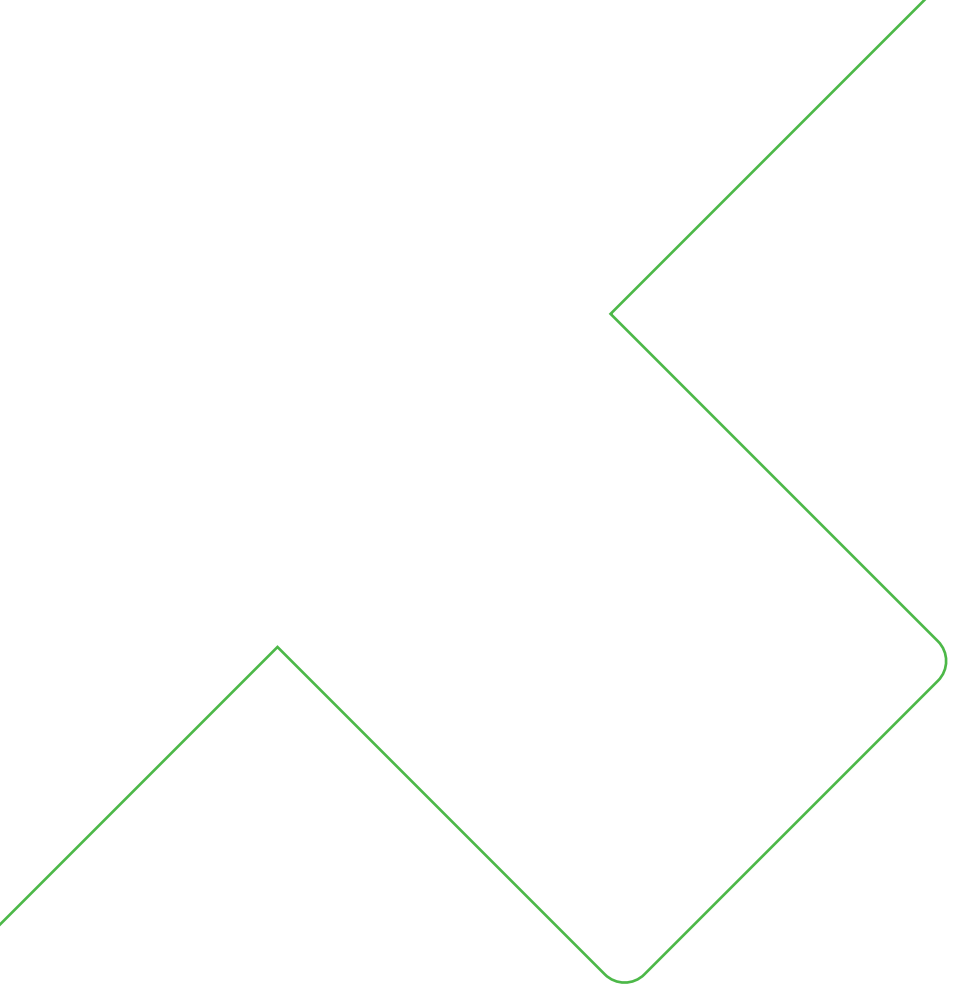

Company Headquarters &  
Production Site

**E+E Elektronik Ges.m.b.H.**  
Langwiesen 7  
4209 Engerwitzdorf | Austria  
T +43 7235 605-0  
F +43 7235 605-8  
info@epluse.com  
www.epluse.com

Subsidiaries

**E+E Sensor Technology (Shanghai) Co., Ltd.**  
T +86 21 6117 6129  
info@epluse.cn

**E+E Elektronik France SARL**  
T +33 4 74 72 35 82  
info.fr@epluse.com

**E+E Elektronik Deutschland GmbH**  
T +49 6171 69411-0  
info.de@epluse.com

**E+E Elektronik India Private Limited**  
T +91 990 440 5400  
info.in@epluse.com

**E+E Elektronik Italia S.R.L.**  
T +39 02 2707 86 36  
info.it@epluse.com

**E+E Korea Co., Ltd.**  
T +82 31 732 6050  
info.kr@epluse.com

**E+E Elektronik Corporation**  
T +1 847 490 0520  
info.us@epluse.com



—  
your partner  
in sensor  
technology.