



WIKAI LevelGuard™ Anti Clog Attachment for Tronic Submersible Liquid Level Transmitters

Tronic

Fits Types: LS-10 submersible
LH-10 high performance submersible
IL-10 high performance intrinsically safe submersible

- For lift stations, wet wells and other level applications
- All 316 stainless steel construction for durability
- 2" diameter diaphragm provides excellent sensitivity
- Diaphragm is protected from physical damage and turbulence
- added weight prevents movement of the transmitter

The WIKAI LevelGuard™ attachment for submersible transmitters is designed for difficult level sensing applications where sludge, slurry, or turbulence may be present. It is available with the LS-10, LH-10 high performance, and IL-10 FM Approved intrinsically safe submersible level transmitters.

The large, two inch diaphragm provides excellent sensitivity and performance even when used to monitor extremely low liquid levels or when the assembly is buried in a layer of sludge or slurry. The cable supplied with WIKAI submersible pressure transmitters is designed to withstand over 200 pounds of strain so no additional support or conduit connections are required.



The rugged all stainless steel LevelGuard™ provides excellent durability and service life in difficult environments.

Dimensions:

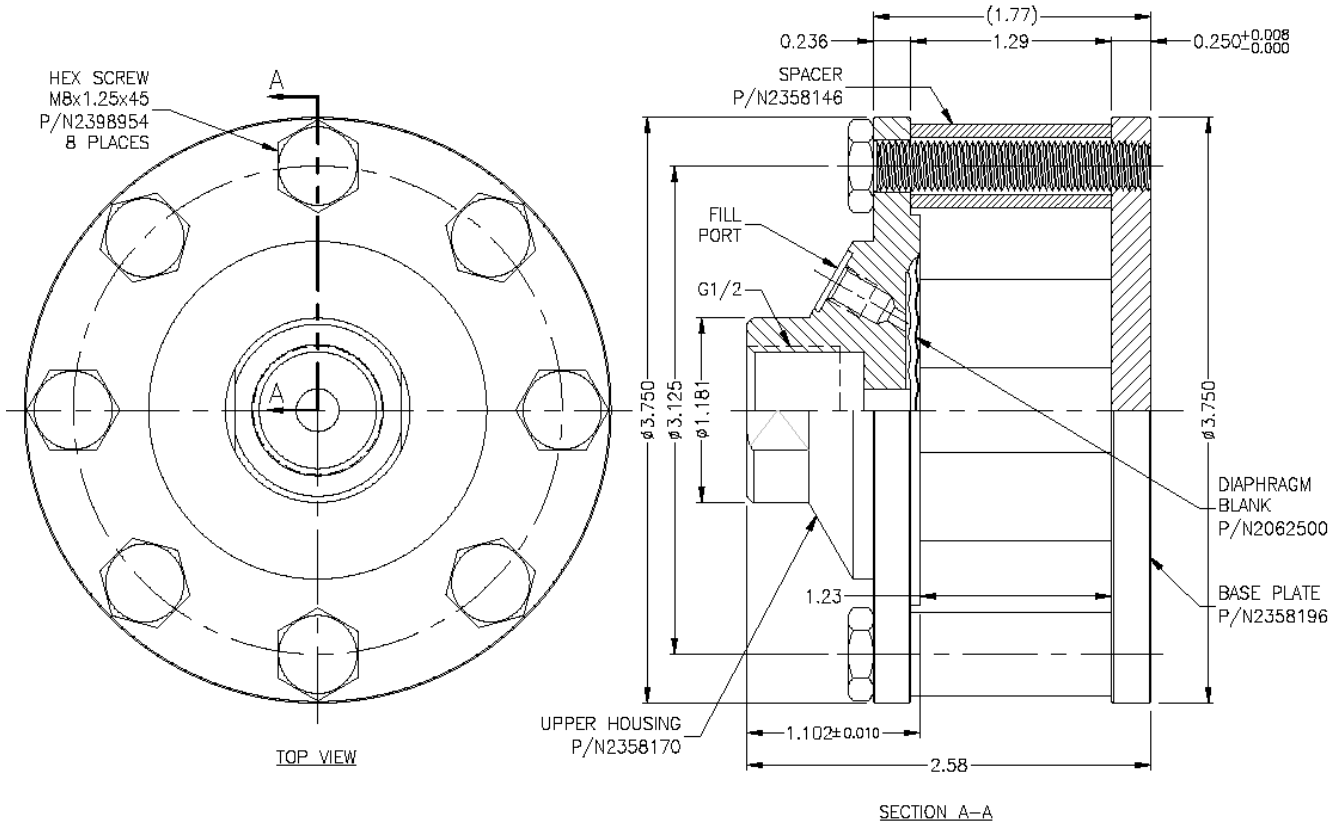

Ordering Information:

State computer part number (if available) / type number / range / output / process connection / electrical connection / other required options.

Specifications given in this data sheet represent the state of engineering at the time of printing. Modifications may take place and the specified materials may change without prior notice.



WIKAL Instrument Corporation

1000 Wiegand Boulevard

Lawrenceville, Georgia 30043-5868

Tel: 770-513-8200 Fax: 770-277-2641

http://www.wika.com e-mail: Tronic@wika.com