

WMX-SERIES



MUNICIPAL/INDUSTRIAL MAGMETER INSTRUCTIONS



WMX-SERIES MUNICIPAL/INDUSTRIAL MAGMETER INSTRUCTIONS

TABLE OF CONTENTS

General Information

General Information, Features Page 1

Specifications

Specifications, Flow Range Page 2

Installation and Grounding

Positioning the Meter, Straight Pipe Recommendations, Full Pipe Recommendations, Fittings, Calibration, Chemical Injection, Metal Pipe Installations, Plastic Pipe Installations Page 3

Straight Pipe Recommendations Page 4

Full Pipe Recommendations Page 5

Inputs/Outputs and Operation

Power, Pulse Output, High Frequency, K-Factor, Display Reading Page 6

Connections Diagrams

AO55/WMX101, FT420/WMX101, DL75 or DL76/WMX101 Page 7

Troubleshooting

Problem, Probable Cause, Things to Try Page 8

TABLES, DIAGRAMS & CHARTS

Features Page 1

Specifications Page 2

Flow Range Page 2

Metal Pipe Installation, Plastic Pipe Installation Page 3

Straight Pipe Recommendations Page 4

Full Pipe Recommendations Page 5

High Frequency Output Page 6

Display Readings Page 6

Connections Diagrams Page 7

Troubleshooting Page 8

GENERAL INFORMATION

The **WMX-Series** are flanged electromagnetic flowmeters for use in 4" to 10" pipe in municipal or industrial water and wastewater applications where propeller meters have typically been used in the past. Because the WMX has no moving parts and has electrodes designed to discourage fouling, this magmeter performs well and requires much less frequent maintenance in applications where debris or sand would impede propeller meters. There is no rotor to stop turning or bearings to wear out. Minimal straight pipe requirements allow WMX-Series meters to be used in piping configurations where there is little space between the meter and an elbow.

In chemical injection applications, the meter should be placed upstream of the injection line or far enough downstream for thorough mixing to occur before the meter.

Rate and total indication are standard on both models. Flow measurement units are customer-selected and factory-set and can only be changed in the field by an authorized Seametrics dealer.

The **WMX101** is externally powered with 7-26 Vdc at 30 mA max (see WARNING on Wiring Diagrams). Two Lithium 3.6V "AA" batteries provide backup during power failures, allowing the meter to seamlessly continue recording flow rate and total for the duration of the outage. Under intermittent use, the battery life is approximately 10 years.

The 20-foot power cable also provides pulse output for use with a variety of Seametrics and other displays and controls for remote reading, data logging, pulse-to-analog conversion, and telemetry applications. An internal data logger is also available for secure flow logging (-127 option). Pulse rate is customer-selected and factory-set and can only be changed in the field by an authorized Seametrics dealer. Default is high frequency for use with 4-20 mA signal conversion devices.

The **WMX104** is a battery-operated unit for use when no additional input or output is required. The Lithium 3.6V "D" batteries are replaceable with an approximate 1-year life under continuous use, or more, depending on the duty cycle. An optional cable can be installed post-factory if power or pulse output is needed for changing applications.

FEATURES

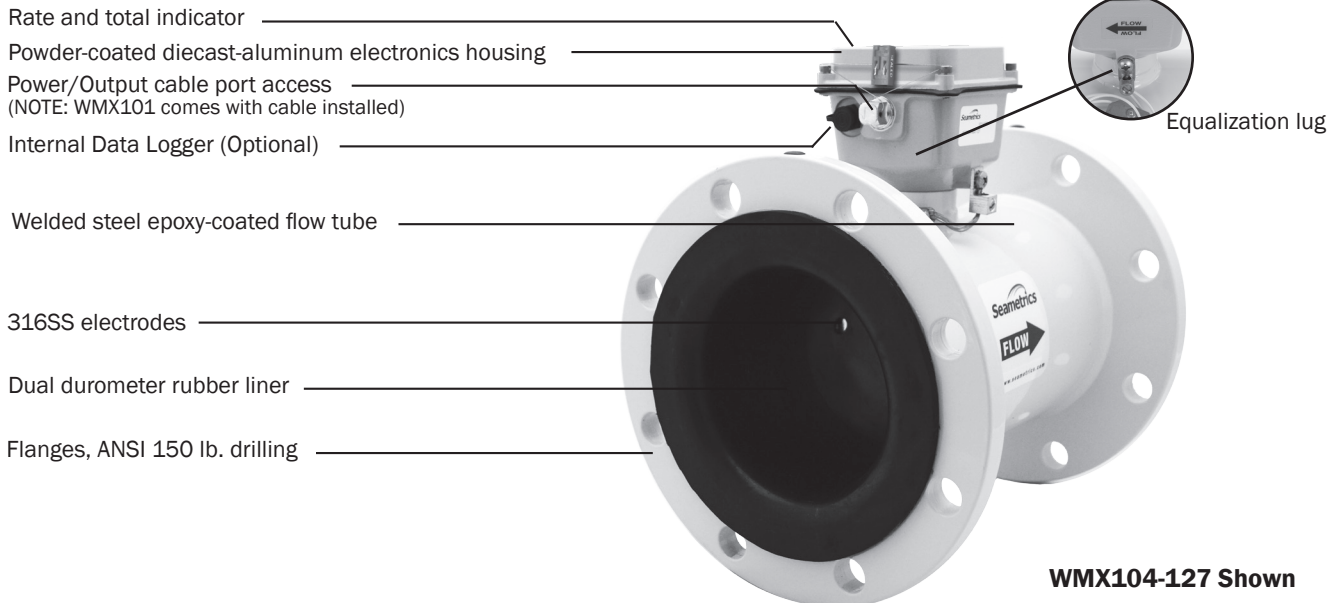

SPECIFICATIONS

SPECIFICATIONS*

Pipe Sizes	4", 6", 8", 10"						
Fittings	ANSI 150 lb. drilling						
Pressure	150 psi (10.3 bar) working pressure						
Temperature	Operating	10° to 130° F (-12° to 54° C)					
	Non-Operating	-40° to 158° F (-40° to 70° C)					
Accuracy	+/-1% of reading from 10% to 100% of max flow						
	+/-2% of reading from cutoff to 10% of max flow						
Materials	Body	Welded steel, epoxy-coated					
	Liner	Dual durometer rubber					
	Electronics Housing	Diecast aluminum, powder-coated					
	Electrodes	316 stainless steel					
Display	Digits	Rate					Total
		5					8
	Units	Gallon/Minute, Liter/Minute, Liter/Second, Cubic Feet/Minute, Cubic Meter/Hour, Million Gallon/Day, Mega Liter/Day				Gallon, Gallon x 1000, Liter, Liter x 1000, Mega Liter, Cubic Meter, Cubic Meter x 1000, Cubic Feet, Cubic Feet x 1000	
Power	WMX101: 7-32 Vdc at 30 mA max, with auxiliary battery for continuous operation during power failures NOTE: Using an unregulated power supply >18 Vdc may damage the meter due to AC line input voltage fluctuation						
	WMX104: 2 Lithium 3.6V "D" batteries, replaceable, 1 year life under continuous use						
Pulse Output	Signal	WMX101: Current sinking pulse, opto-isolated, 30 Vdc at 10 mA max					
		WMX104: Pulse output available only with addition of post-factory output cable					
	Pulse Rates	High Frequency (default); 10 units/pulse; 100 units/pulse; 1000 units/pulse					
	High Frequency (pulse/gal)	4"	6"	8"	10"		
16.362		6.307	3.344	2.150			
Conductivity	>20 microSiemens/cm						
Empty Pipe Detection	Hardware/software, conductivity-based						
Environmental	NEMA 4X Standard						

*Specifications subject to change. Please consult our website for the most current data (www.seametrics.com).

FLOW RANGE

	4"		6"		8"		10"	
	Gal/Min	Liter/Sec	Gal/Min	Liter/Sec	Gal/Min	Liter/Sec	Gal/Min	Liter/Sec
Minimum	12	.75	32	2	60	3.8	95	6
Maximum	500	31.5	1,200	75.7	2,200	138.8	3,500	220.8

INSTALLATION and GROUNDING

INSTALLATION



Caution: These flow sensors are not recommended where installation fault may expose the flow sensor to boiler pressure and temperature. Maximum recommended temperature is 130° F.

Positioning the Meter. These meters can be installed horizontally, vertically, and in any radial position.

Straight Pipe Recommendations. As with most flow meters, the WMX requires some straight pipe before and after the meter for best accuracy. However, the ability of electromagnetic meters to average the flow across the entire pipe allows for shorter straight pipe recommendations than most mechanical meters (see page 4).

Full Pipe Recommendations. All magmeters require a method for determining that the pipe is empty, to prevent false reading. This meter is designed to go to zero reading if one or more electrodes is exposed. For highest accuracy, install the meter so that the pipe will be full when there is flow. If air bubbles may be present in the pipe or sludge accumulation is an issue, rotate the meter by one flange hole to position the control housing at a 45° angle (see page 5).

Fittings. The WMX flanges have standard ANSI 150 lb. drilling and mate with any other ANSI 150 lb. flange.

Calibration. The WMX is factory-calibrated and will not require any form of field calibration.

Chemical Injection. When any magmeter, by any manufacturer, is used in a chemical injection application, the chemical injection point must be placed downstream of the magmeter OR far enough upstream for **complete mixing** to occur before the fluid reaches the meter. When unmixed chemical alternates with water passing through the meter, the rapid changes in conductivity may cause sudden spikes and drops in the meter's reading, resulting in inaccurate measurement. The magmeter will restabilize, however, with a steady flow of fluid of uniform conductivity.



Caution: In chemical injection applications, install chemical injection point downstream of magmeter, or far enough upstream to allow complete mixing of fluids before the meter.

EQUALIZATION AND GROUNDING

Metal Pipe Installations. To equalize the electrical potential of the fluid, the WMX meter, and the surrounding pipe, secure the flange plates (factory-installed on the equalization lug) to both pipe flanges at one of the bolt holes, as shown below. Be sure the lockwasher fits between the pipe flange and the flange plate.

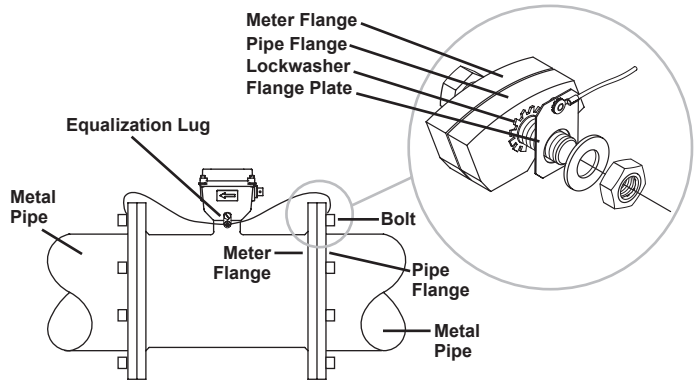

Equalization Diagram

Run wire from equalization lug to both pipe flanges; secure flange plates under bolt heads as shown.



WARNING: ELECTRICAL SHOCK HAZARD When the meter is externally AC powered (WMX101 or adapted 104), the piping system must be grounded to meet national and local electrical safety codes. Failure to do so can result in electrocution.

Plastic Pipe Installations. When the WMX is installed in a plastic piping system, it is not necessary to use the equalization straps, but very important to ground the meter to avoid electrical shock hazard and electrostatic interference with meter function.

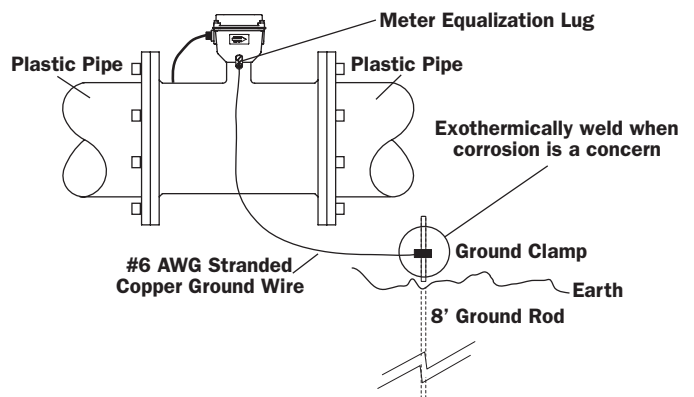

STRAIGHT PIPE RECOMMENDATIONS

(X = diameter)

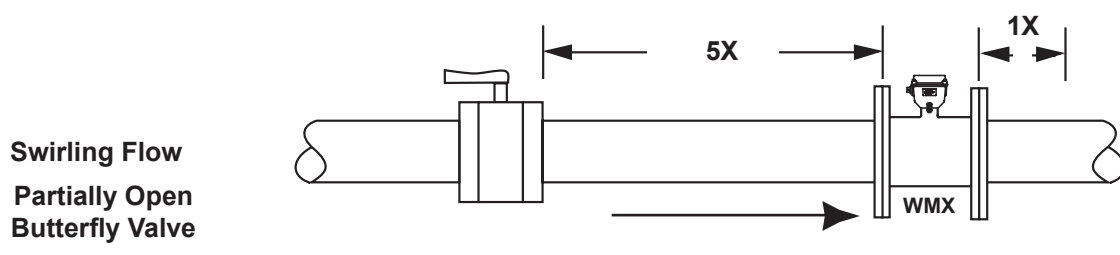
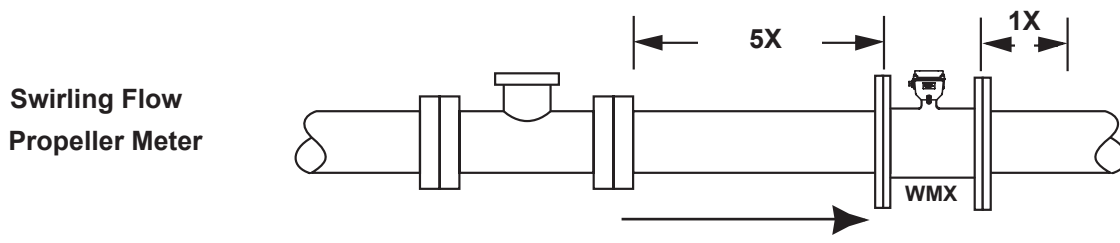
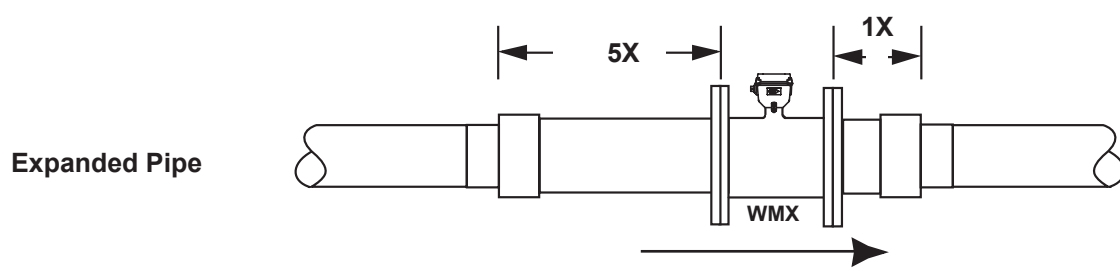
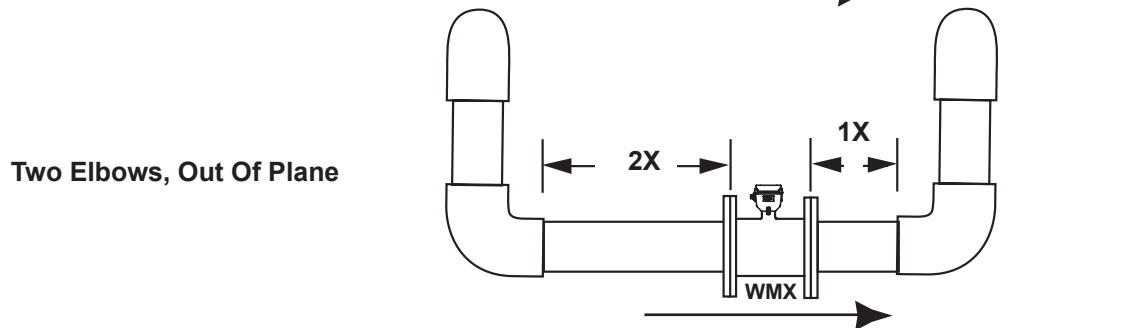
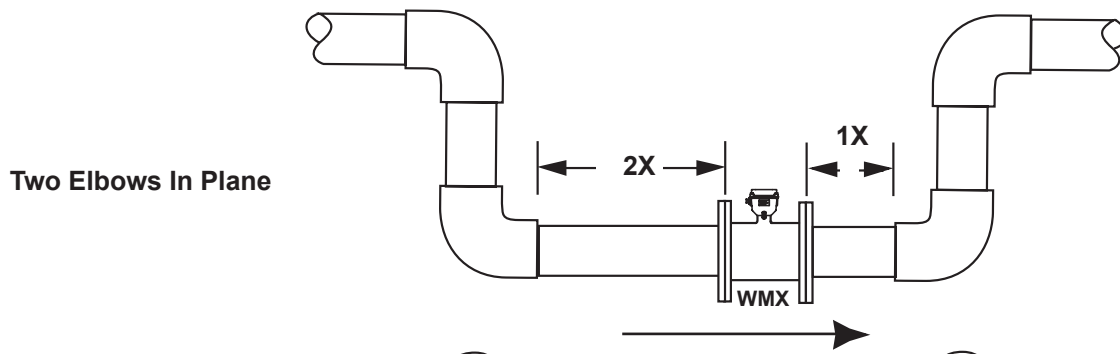
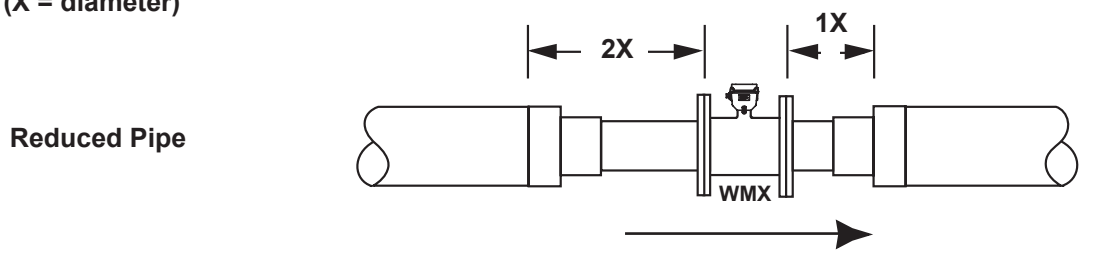

FULL PIPE RECOMMENDATIONS

Recommended:
Keep pipe full at meter for accuracy

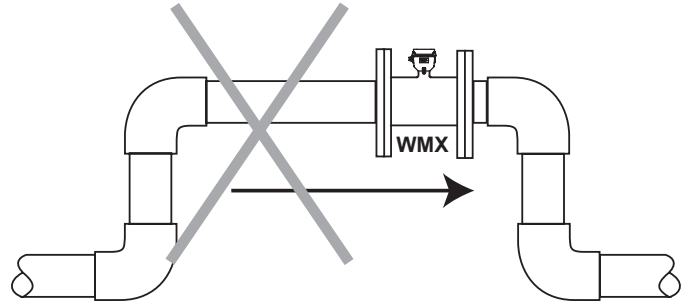
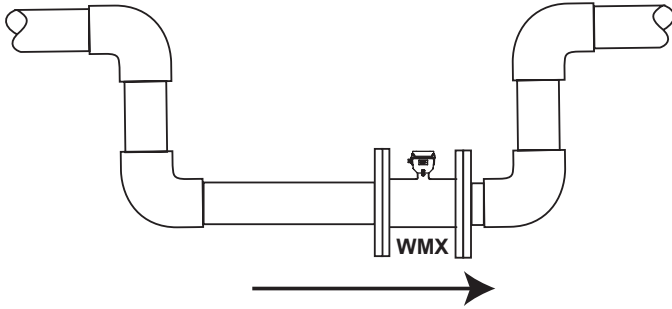

Not Ideal:
Allows air pockets to form at meter

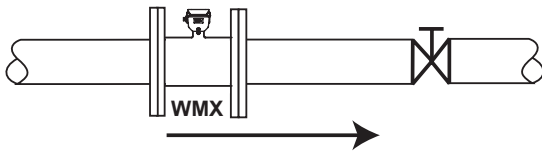

Recommended:
Keeps pipe full at meter for accuracy

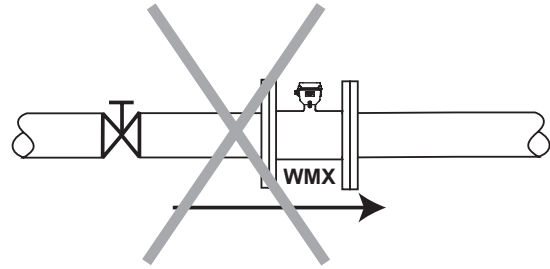

Not Ideal:
Post-valve cavitation can create air pocket

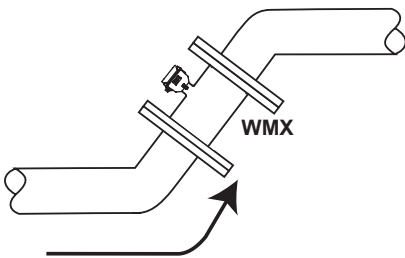

Recommended:
Allows air to bleed off

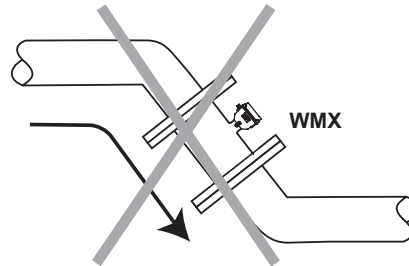

Not Ideal:
Air can be trapped

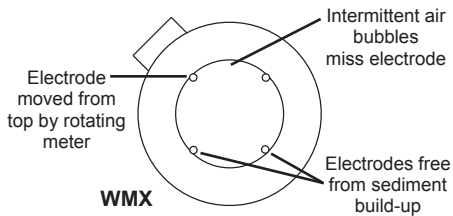

Recommended:
Improved accuracy results from unimpeded electrodes

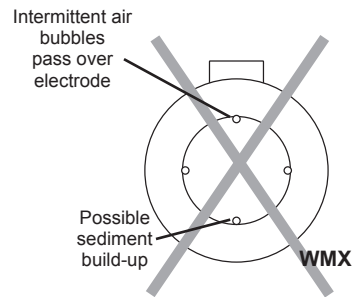

Not Ideal:
Air bubbles and sediment on the electrodes can affect accuracy

INPUTS/OUTPUTS and OPERATION

WMX101

External Power (WMX101). The WMX101 operates on 7-26 Vdc at 30 mA max external power (see WARNING in wiring diagrams). The display reads “P” when external power is in use (see illustration below).

The Lithium battery pack installed in the WMX101 serves as backup in the event of a power failure, when it will keep the meter operating without interruption for the duration of the outage. When battery power is in use, the WMX101 display continues to read out the rate and total, but the “P” indicating external power is extinguished. When power resumes, the WMX101 will seamlessly return to normal power mode, and the “P” will again display.

When used for occasional emergency backup, battery life is approximately ten years.

Pulse Output (WMX101). The WMX101 cable also provides pulse output that can be used for remote reading, 4-20 mA signal conversion, datalogging, and telemetry applications. See page 7 for connection diagrams to Seametrics controls and displays.

Note: For data logger setup and operation, refer to Flow Inspector Manual

Pulse rates are selected by the customer at time of order, factory-set, and can only be changed in the field by an authorized Seametrics dealer. Three pulse rates are possible: One pulse per ten gallons (or liters), one pulse per thousand gallons (or liters), or High Frequency (required for use with 4-20 mA converters; see below):

High Frequency Output/K-Factor		
Meter Size	Pulses per Gallon	Pulses per Liter
4"	16.362	4.323
6"	6.307	1.666
8"	3.344	0.883
10"	2.150	0.568

WMX104

Battery Power (WMX104). The WMX104 is powered by a non-rechargeable battery pack with an average lifespan of one year under typical (full-time) use. Actual lifespan will vary from application to application, depending on the duty cycle.

“Low Batt” will display when there are approximately three days of use left in the batteries (see illustration). Replacement instructions come with the custom battery pack available from your dealer or Seametrics.

Pulse Output (WMX104). Pulse output capabilities are built in to the WMX104, but cannot be utilized without the addition of an optional output cable. A WMX104 can be retrofitted with this cable in the field. **IMPORTANT:** When field installing the input/output cable, be sure to snugly tighten the cable strain relief to prevent water ingress.

OPERATION



Caution: There are no user-adjustable connections or settings inside the display housing. Use caution when opening the housing for a battery change, to avoid damage to internal components.

Display Reading. The WMX display has two lines, the bottom line for flow rate and the top line for accumulated total. Measurement units are pre-ordered and factory-set and can be changed in the field only by an authorized individual.

Refer to the diagrams below to read your display.



**External Power Indicator
(WMX101 Only)**



No Power



**Battery Power
(WMX104 Standard Operation)
(WMX101 Backup Operation)**

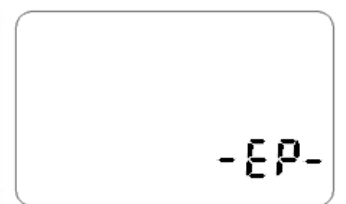

Empty Pipe

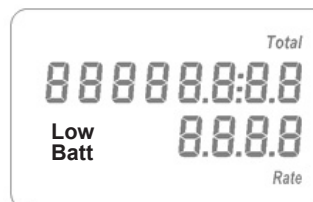

**Low Battery Indicator
(3 days remaining)**



Meter Installed Backwards

CONNECTIONS DIAGRAMS (WMX101)

The **WMX101** requires a power source of 7 to 26 Vdc at 30 mA max (see **WARNING**). The WMX101 power cable also serves as a pulse output if needed for remote reading, data logging, signal conversion, or telemetry.

WMX101 Cable Color Codes

Orange and Blue: Serial Output (Do Not Use)

Green (+) and White (-): Pulse Output, 30 Vdc max, 10 mA max

Red (+) and Black (-): External Power, 7-26 Vdc at 30 mA max

Drain: Connect to earth ground (see **WARNING**)

A055/WMX101

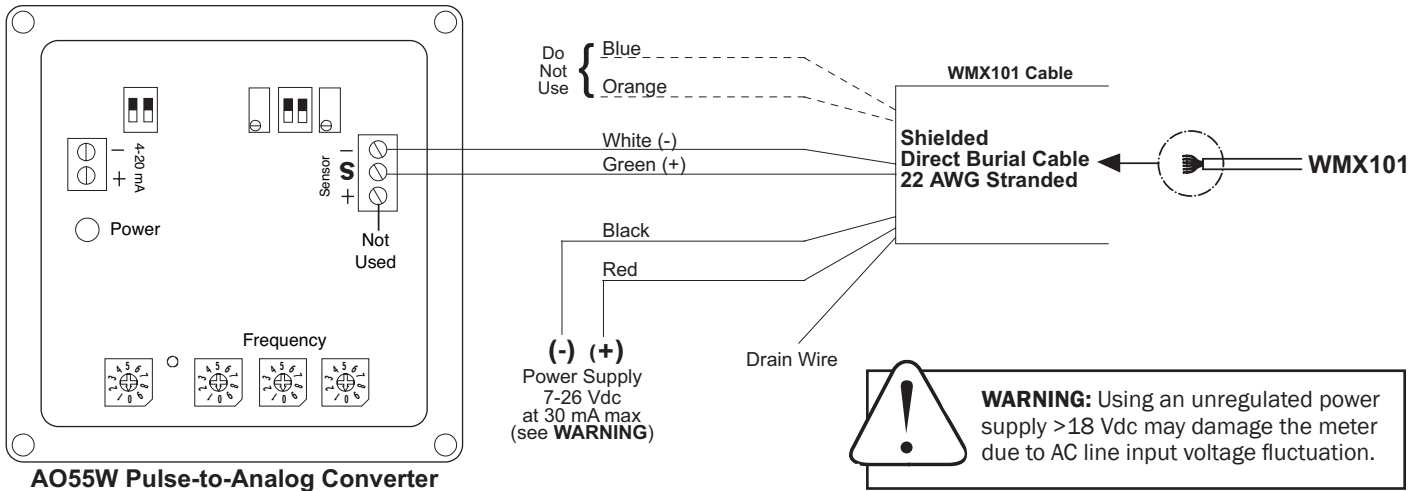

FT420/WMX101

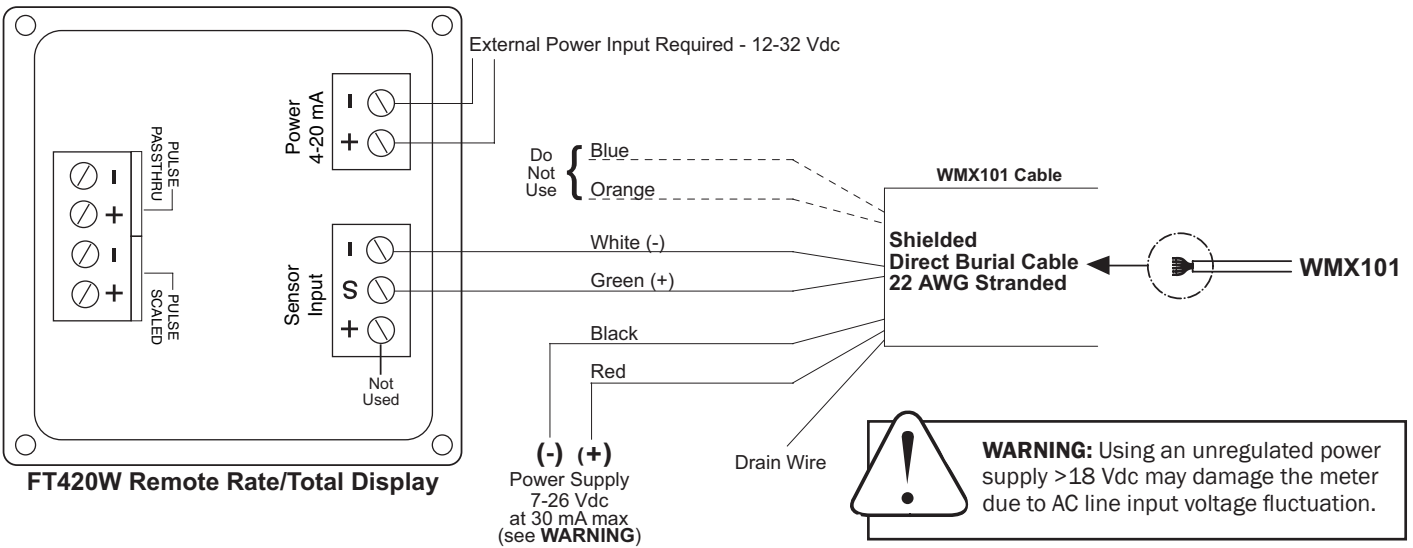

DL75 or DL76/WMX101

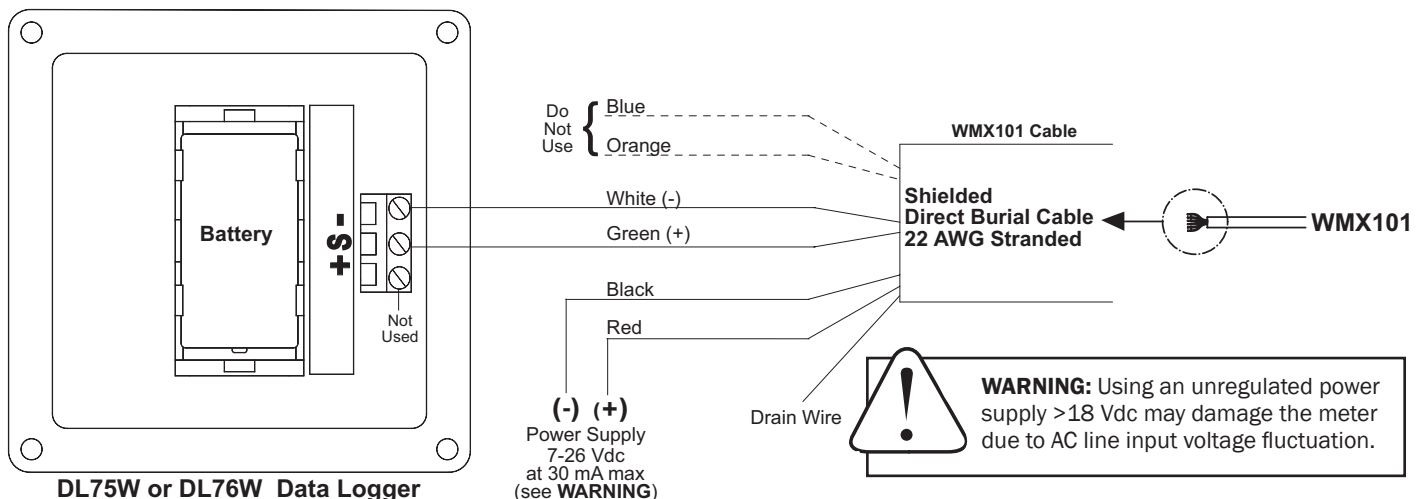

TROUBLESHOOTING

Problem	Probable Cause	Try...
Blank Display	Dead battery (WMX104) No power plus dead battery (WMX101)	Replace battery pack Replace battery pack, check power connections
Flow rate steadily reads zero when there is flow	Flow is below cutoff (very low) Pipe is not full Meter is installed backwards (display reads [-]) Power connections reversed (WMX101) Fluid conductivity <20mSiemens/cm	Reading will resume when flow increases Reposition meter for full pipe (see page 4) Note flow direction arrow, reverse meter Change power connections Select another flow meter
Flow rate intermittently drops when there is flow	Pipe is not full	Reposition meter for full pipe (see page 4)
Jumpy reading	Missing or incorrect ground wire Pulsing flow Rapidly changing conductivity (in chemical injection applications)	Check for proper ground Use external power source (allows more flow averaging) Install chemical injection line downstream of meter (or far enough upstream to allow complete mixing of fluids before meter)
Meter reads, but no pulse output (WMX101)	External device needs pull-up resistor Reversed leads (polarity sensitive)	Add pull-up resistor (For details, refer to 'Connecting to PLCs' Technical Bulletin at www.seametrics.com) Change output connections
Output pulses missing	Meter not reading	Check display



Seametrics Incorporated • 19026 72nd Avenue South • Kent, Washington 98032 • USA
(P) 253.872.0284 • (F) 253.872.0285 • 1.800.975.8153 • www.seametrics.com