

WMP-Series



PLASTIC-BODIED MAGMETER INSTRUCTIONS

WMP-SERIES PLASTIC-BODIED MAGMETER INSTRUCTIONS

3 inch



2 inch

1 inch

GENERAL INFORMATION and FEATURES

GENERAL INFORMATION

The WMP-Series is a full-bore, plastic-bodied electromagnetic flow meter designed for flow and usage monitoring applications in 1, 2 and 3 inch pipe. The polypropylene flow tube offers corrosion resistance to a wide range of chemicals. Its light weight and easy to install or remove from the pipe for inspection.

With no moving parts, the magmeter permits unobstructed flow, minimizing flow disturbances and hence, straight pipe requirements. The WMP-Series can be used in piping configurations where there is little space between the meter and an elbow or valve. The WMP-Series, like other magmeters, are resistant to wear from sand and debris found in ground or surface water. Since there are no bearings or propeller to wear out, downtime and maintenance and repair costs are kept to a minimum. Because there are no mechanical parts in the flow stream, the meter tolerates high flows without damage.

The hinged, opaque polyethylene cover protects from dust and UV rays, while permitting easy access to the LCD flow rate and total display. The electronics housing is made of rugged powder-coated die-cast aluminum. It can be fitted with cross-drilled screws and seal wire for tamper-evidence. Flow rate and total can be displayed in a variety of units, customer-selected and factory-set.

The WMP-Series is used for tracking flow rate and total flow in usage monitoring applications, for instance, in compliance with regulatory requirements. These would include wells, industrial

wastewater, gray water, irrigation metering, turf and landscape applications, and other water reclamation operations. In the event of DC power loss, or when changing the battery, the WMP is designed to retain the internal settings and flow total.

The **WMP101** is externally powered via a 5-pin connector and the power cable also provides pulse output for use with a variety of Seametrics and other displays and controls for remote reading, data logging, pulse-to-analog conversion, and telemetry applications.

The **WMP104** is a battery-operated unit for use when pulse output is not required. The standard batteries are user replaceable with an approximate 1-2 year life depending on usage. An extended battery life option offers an estimated 2-4 year life depending on usage.

FEATURES

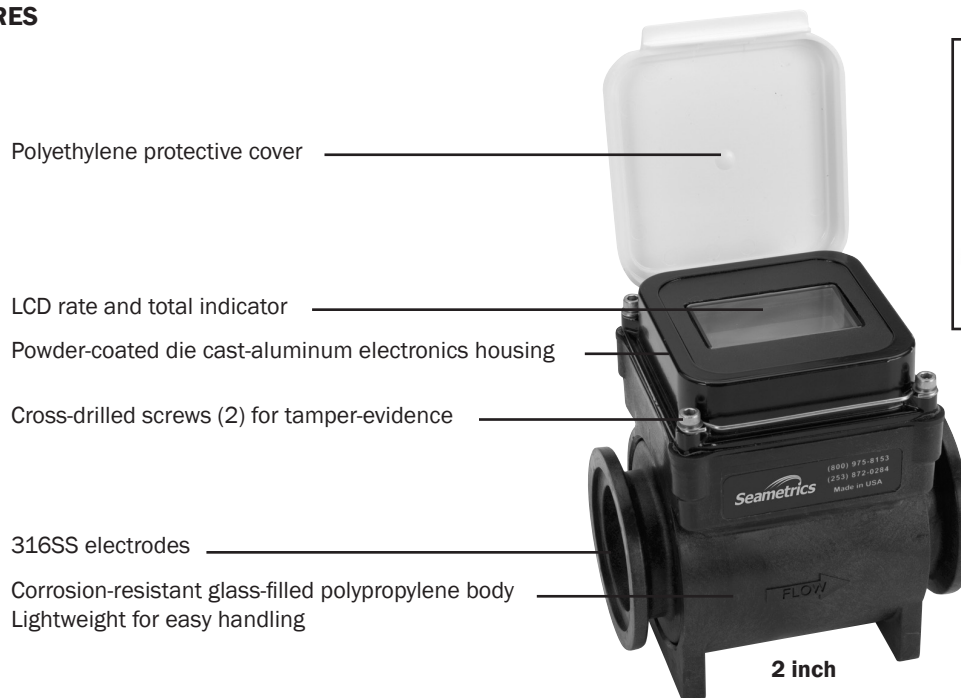

**Seametrics Fitting Kit
for 2 and 3 inch models**

SPECIFICATIONS*

Pipe Size	1, 2 or 3 inch full port		
Fittings	1 inch NPTF, 2 or 3 inch flange clamps with 2 or 3 inch NPTF fitting kit		
Pressure	150 psi or 10.3 bar working pressure @ 70° F		
Operating Temperature Range	10° to 130° F (-12° to 54° C) operating, -40° to 176° F (-40° to 80° C) non-operating		
Accuracy	+/-1% of reading (between 10% and 100% of max flow) +/-3% of reading (between cutoff and 10% of max flow)		
Flow Range	Minimum	1 inch: 2.3 GPM (.145 LPS) 2 inch: 6 GPM (.38 LPS) 3 inch: 14 GPM (.88 LPS)	
	Maximum	1 inch: 110 GPM (6.94 LPS) 2 inch: 300 GPM (18.9 LPS) 3 inch: 670 GPM (42.3 LPS)	
Materials	Body	Glass-filled polypropylene	
	Electrodes	316 stainless steel	
	Electronics Housing	Diecast aluminum, powder-coated	
	Display Cover	Polyethylene	
Display	Rate		Total
	Digits	6	8
	Units	Gallons/Minute, Cubic Feet/Second, Cubic Feet/Minute, Liters/Second, Liters/Minute, Cubic Meters/Minute	Acre-Feet, Acre-Inch, Gallons, Gallons x 1000, Cubic Feet, Liters, Megaliters, Cubic Meters
Security	Cross-drilled screws and tamper-evident seal (optional)		
Power	WMP101	10-30 Vdc @ 60 mA max (15 mA average) NOTE: Using an unregulated power supply >18 Vdc may damage the meter due to AC line input voltage fluctuation	
	WMP104	6 each AA alkaline cells, replaceable. Estimated life is 1-2 years depending on usage (standard) 2 each C lithium batteries, replaceable. Estimated life is 2-4 years depending on usage (Extended battery life option)	
Pulse Output Signal (WMP101 Only)	Current sinking pulse, opto isolated, 32 Vdc max at 10 mA max		
Pulse Rate (WMP101 Only)			
	Low Frequency (-PxU)	1 unit/pulse out, pulse width of 10ms depending on unit selection	
	High Frequency (-HF)	1"	2"
		3"	Pulse width 1.1 ms, min - max frequency, 3 - 150 hz
	Pulse/Unit	80	30
		13	
Empty Pipe Detection	Hardware/software, conductivity-based		
Conductivity	>20 microSiemens/cm		
Environmental	NEMA 4X standard		
Electrical Connection (WMP101 Only)	5 pin male circular connector, mates to industry standard cable		

*Specifications subject to change • Please consult our website for current data (www.seametrics.com)

DIMENSIONS

Power/Output Cable
- WMP101 Only

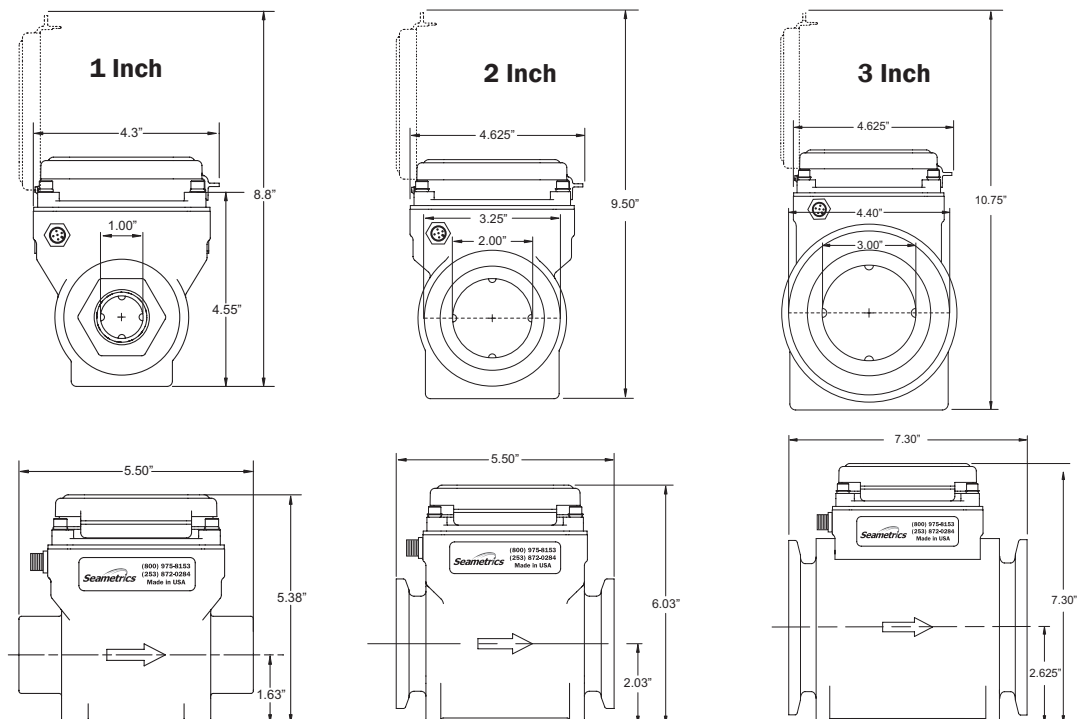

FLOW RANGE, INSTALLATION

FLOW RANGE

	1"		2"		3"	
	Gal/Min	Liter/Sec	Gal/Min	Liter/Sec	Gal/Min	Liter/Sec
Minimum	2.3	.145	6	.38	14	.88
Maximum	110	6.94	300	18.9	670	42.3

INSTALLATION

Piping Conditions. Installing the meter with a length of straight pipe at least two times the diameter upstream and one diameters downstream is highly recommended. Some piping conditions require more than this. See chart for recommendations.

End Connections. The meter comes with Banjo™ union-type flange connections for ease in servicing the meter. To connect these to piping ends, a variety of kits are available from any Banjo dealer or from Seametrics.

Follow the diagram below to make the connections.

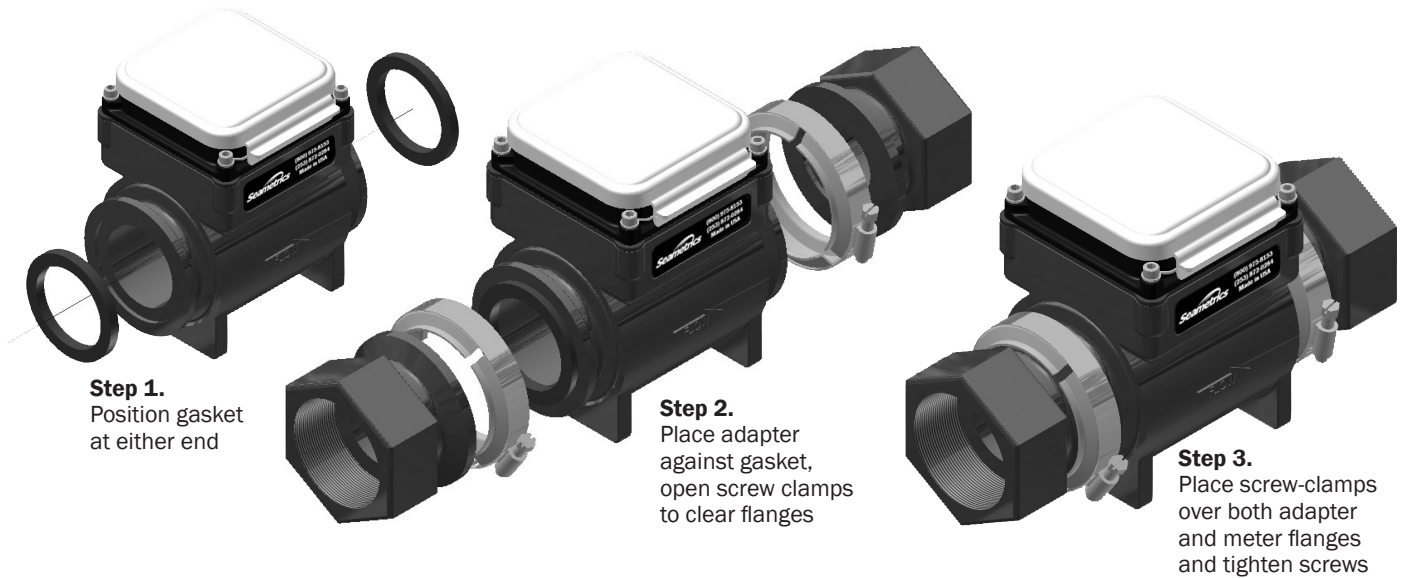

NOTE: Above installation instructions are for WMP101/104-200 (2") and WMP101/104-300 (3") only. The WMP101/104-100 (1") is provided with intergrated NPT female threaded ends.

Position. This is an all position meter which can be installed either vertically or horizontally, register up, down or angled. However, entrained air or solids may make some positions preferable to others. See the position diagram for guidance.

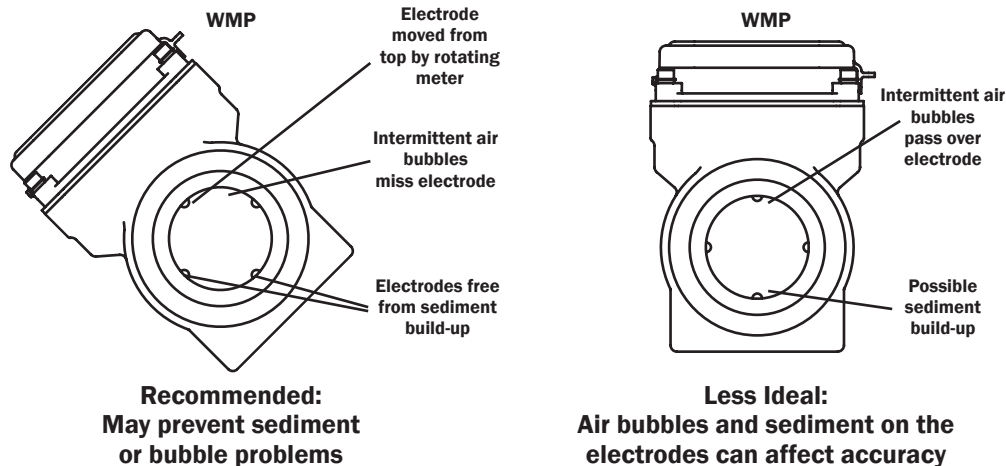

STRAIGHT and FULL PIPE RECOMMENDATIONS

(X = diameter)

Reduced Pipe

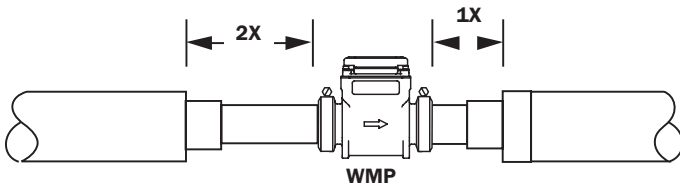

Expanded Pipe

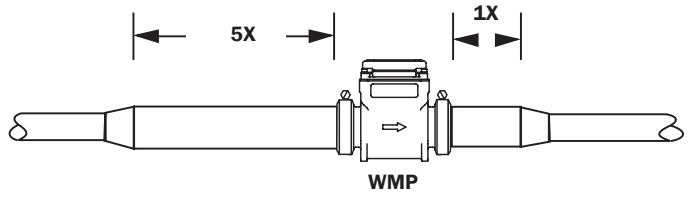

Elbows

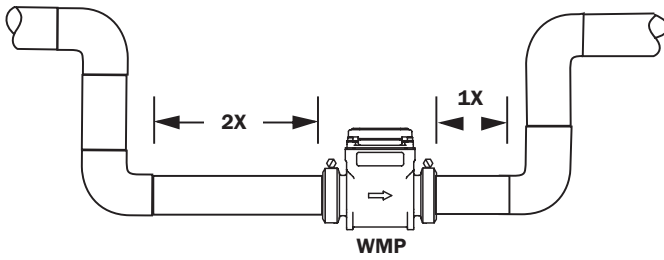

Swirling Flow: Partially Open Butterfly Valve

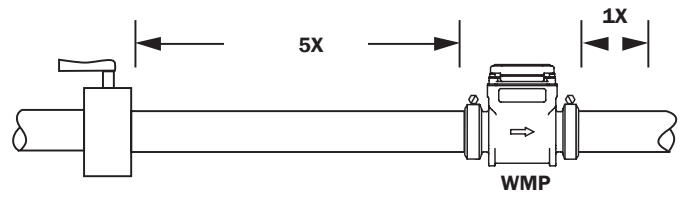

**Recommended:
Keep pipe full at meter
for accuracy**

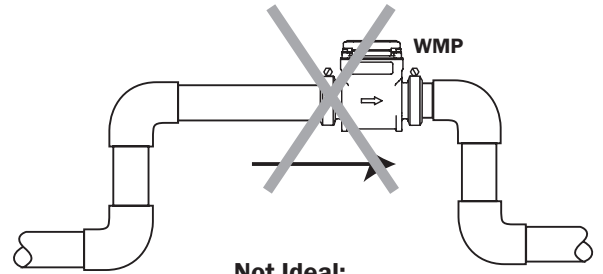
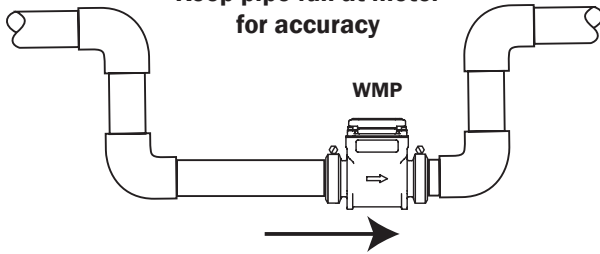

**Not Ideal:
Allows air pockets to form at meter**

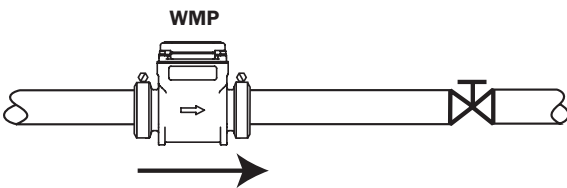

**Recommended:
Keeps pipe full at meter for accuracy**

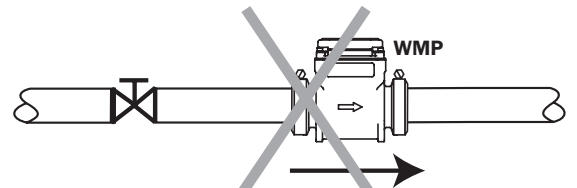

**Not Ideal:
Post-valve cavitation can create air pocket**

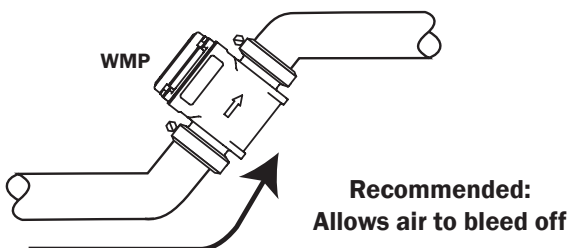

**Recommended:
Allows air to bleed off**

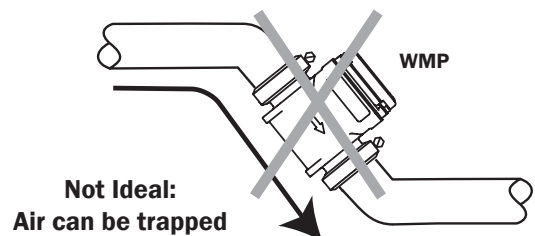

**Not Ideal:
Air can be trapped**

ELECTRICAL CONNECTIONS

WMP104. The WMP104 is battery-powered totally self-contained and does not require any electrical connections (there is no output on the WMP104 model).

WMP101. A connector is provided on the outside of the WMP101. To connect to the meter, plug the cable in and hand tighten the retaining threads. Follow the diagram to make connections. If you are using the pulse output, connect power first and determine that the meter is working properly by observing the display. Then connect the pulse output.

CABLE CONNECTIONS

Gray: Pin 5 = Ground
Black: Pin 4 = (-) Power
Blue: Pin 3 = (+) Pulse
White: Pin 2 = (-) Pulse
Brown: Pin 1 = (+) Power
Shield Drain Wire

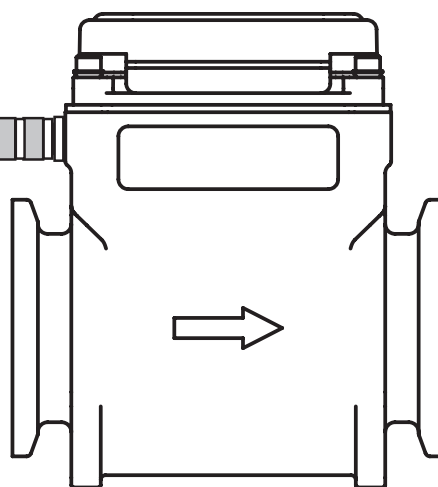

OPERATION

Grounding (WMP101). For best performance, especially in chemically noisy environments, the gray ground wire and the bare drain wire should be connected together and to a good earth ground as close to the meter as possible. Metal pipe and fittings in contact with the fluid should also be bonded to the same earth ground with corrosion-resistant connections.

Display. The display reads flow rate and accumulated total, in the units for which it was ordered. The top line is total, the bottom line is rate, and indicators give the units (ac-ft, GPM for instance.) Empty or partially-full pipe is automatically detected and is indicated by a reading of “ - EP - “.

Battery. The standard batteries are user replaceable with an approximate 1-2 year life depending on usage. An extended battery life option offers an estimated 2-4 year life depending on usage. On the battery-powered WMP104 there is a low-battery indicator (“low bat”) when the battery voltage drops below a certain point. Batteries should be changed within four weeks of the appearance of this indicator.

MAINTENANCE AND REPAIR

There are no user-serviceable parts in the WMP-Series meters except the batteries in the WMP104.

Battery Replacement. When the “low bat” indicator appears, the batteries should be changed. Either six each AA alkaline cells are required, or two each C lithium cells with integrated wiring harness, depending on power option ordered with meter. To change the batteries, first remove the four screws which hold the top cover in place. Be careful not to lose the washers. Move the top cover to one side and remove the foam retainer which covers the battery tray or pack.

> For units with AA alkaline batteries, remove the old batteries from the battery tray, and replace them with fresh ones, taking care to follow the polarity indicators in the battery tray.

> For units with the optional C lithium batteries, carefully unplug each of the two battery wiring harness connectors. Slip the batteries out from under the elastic retainer, and replace them with the new batteries. Reconnect each of the two wiring harness connectors. The connectors are indexed for correct installation.

Replace the foam retainer, then put the top cover back in place. Warning! Use Extreme Caution not to pinch wiring or other assembly parts under the housing seal - this may cause an ingress of water, voiding the product warranty. Replace the four screws and washers, then tighten them securely using cross-pattern to evenly compress the gasket. Environmental and Safety note - take care to dispose of all batteries in accordance with Federal, State, and Local regulations.

TROUBLE SHOOTING

Problem	Probable Cause	Try...
Blank display: WMP101	No power to unit	Check power supply Check wiring
Blank display: WMP104	Batteries dead or misinstalled	Check polarity, replace batteries
Reading “-EP-”	Empty or partly filled pipe Excessive air pockets or foaming	Rearrange piping to ensure full pipe
Flow but no flow rate reading	Heavily coated electrodes	Remove meter and wipe electrodes



**Seametrics Incorporated • 19026 72nd Avenue South • Kent, Washington 98032 • USA
(P) 253.872.0284 • (F) 253.872.0285 • 1.800.975.8153 • www.seametrics.com**