



## Series WE33 3-Way Tri-Clamp Ball Valve

### Specifications - Installation and Operating Instructions



WE33-DHD00-T2

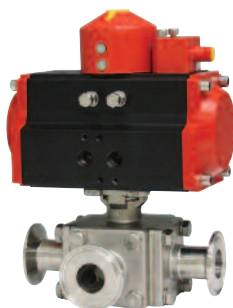

WE33-ESR03-T1-NN07



WE33-DDA01-L1-AA06



WE33-DTD01-T3-A



WE33-DTI01-T2-A

The Series WE33 incorporates a full port 3-way tri-clamp SS ball valve for great flow rates with minimal pressure drop. The valve features a blowout-proof stem for added safety, reinforced PTFE seats and seals for longer life, and a 316 SS (ASTM CF8M) ball for better performance. Actuators are direct mounted creating a compact assembly for tight spaces. Limit switches are able to be mounted directly to the valves allowing for remote position indication.

The Series WE33 can be configured with either an electric or pneumatic actuator. Electric actuators are available in weatherproof or explosion-proof, a variety of supply voltages and two-position or modulating control. Two-position actuators use the supply voltage to drive the valve open or close, while the

modulating actuator accepts a 4 to 20 mA input for valve positioning. Actuators feature thermal overload protection and permanently lubricated gear train.

The pneumatic double acting actuator uses an air supply to drive the valve open and closed. The actuator has two supply ports, with one driving the valve open and the other driving the valve closed. Spring return pneumatic actuators use the air supply to open the valve, and internally loaded springs return the valve to the closed position. Also available is the SN solenoid valve to electrically switch the air supply pressure between the air supply ports for opening and closing the valve. Actuators are constructed of anodized and epoxy coated aluminum for years of corrosion free service.

#### SPECIFICATIONS VALVE

**Service:** Compatible liquids and gases.

**Body:** 3-way.

**Line Sizes:** 1/2 to 2".

**End Connections:** Tri-clamp ends.

**Pressure Limits:** 20" Hg to 1000 psi (-0.7 to 69 bar).

#### Wetted Materials:

Body and ball: 316 SS (CF8M);

Stem: 316 SS;

Seat: RTFE/PTFE;

Seal, Washer, and Packing: PTFE.

**Temperature Limits:** -20 to 392°F (-29 to 200°C).

#### Other Materials:

O-ring: Fluoroelastomer;

Handle: 304 SS;

Washer: 301 SS;

Stem Nut, Locking Device,

Gland Ring: 304 SS;

Handle Sleeve: PVC.

#### ACTUATORS

##### Pneumatic "DA" and "SR" Series

**Type:** DA series is double acting and SR series is spring return (rack and pinion).

##### Normal Supply Pressure:

DA: 40 to 115 psi (2.7 to 7.9 bar);

SR: 80 psi (5.5 bar).

**Maximum Supply Pressure:** 120 psi (8.6 bar).

##### Air Connections:

DA01: 1/8" female NPT;

DA02 to DA03: 1/4" female NPT;

SR02 to SR04: 1/4" female NPT.

**Housing Material:** Anodized aluminum body and epoxy coated aluminum end caps.

**Temperature Limits:** -40 to 176°F (-40 to 80°C).

**Accessory Mounting:** NAMUR standard.

##### Electric "TD" and "MD" Series

**Power Requirements:** 110 VAC, 220 VAC, 24 VAC or 24 VDC (MD models not available in 24 VDC).

**Power Consumption:** See page 8.

##### Cycle Time (per 90°):

TD01: 4 s;

MD01: 10 s;

TD02 and MD02: 20 s.

**Duty Rating:** 85%.

**Enclosure Rating:** NEMA 4X (IP67).

**Housing Material:** Powder coated aluminum.

**Temperature Limits:** -22 to 140°F (-30 to 60°C).

**Electrical Connection:** 1/2" female NPT.

**Modulating Input:** 4 to 20 mA.

**Standard Features:** Manual override, position indicator, and TD models come with two limit switches.

##### Electric "TI" and "MI" Series

**Power Requirements:** 110 VAC, 220 VAC, 24 VAC or 24 VDC.

**Power Consumption:** See page 8.

##### Cycle Time (per 90°):

TI01 and MI01: 2.5 s;

TI02 and MI02: 5 s;

TI03 and MI03: 5 s.

##### Duty Rating:

Two-Position:

TI01-TI03: 25%;

Modulating:

MI01-MI03: 75%.

**Enclosure Rating:** NEMA 7.

**Housing Material:** Powder coated aluminum.

**Temperature Limits:** -40 to 140°F (-40 to 60°C).

**Electrical Connection:** 1/2" female NPT.

**Modulating Input:** 4 to 20 mA.

**Standard Features:** Position indicator and two limit switches.

**POPULAR MODELS**

Size	Cv (gal/min)	Hand Operated Model	Double Acting Pneumatic Model	Spring Return Pneumatic Model	NEMA 4X Two Position Electric (110 VAC) Model	NEMA 4X Modulating Electric (110 VAC) Model
1/2"	14.39	WE33-CHD00-T2	WE33-CDA01-T2	WE33-CSR02-T2	WE33-CTD01-T2-A	WE33-CMD01-T2-A
3/4"	42.25	WE33-DHD00-T2	WE33-DDA01-T2	WE33-DSR02-T2	WE33-DTD01-T2-A	WE33-DMD01-T2-A
1"	86.17	WE33-EHD00-T2	WE33-EDA02-T2	WE33-ESR03-T2	WE33-ETD01-T2-A	WE33-EMD01-T2-A
1-1/2"	223.61	WE33-GHD00-T2	WE33-GDA02-T2	WE33-GSR03-T2	WE33-GTD02-T2-A	WE33-GMD02-T2-A
2"	437.98	WE33-HHD00-T2	WE33-HDA03-T2	WE33-HSR04-T2	WE33-HTD02-T2-A	WE33-HMD02-T2-A

**VALVE BILL OF MATERIALS**

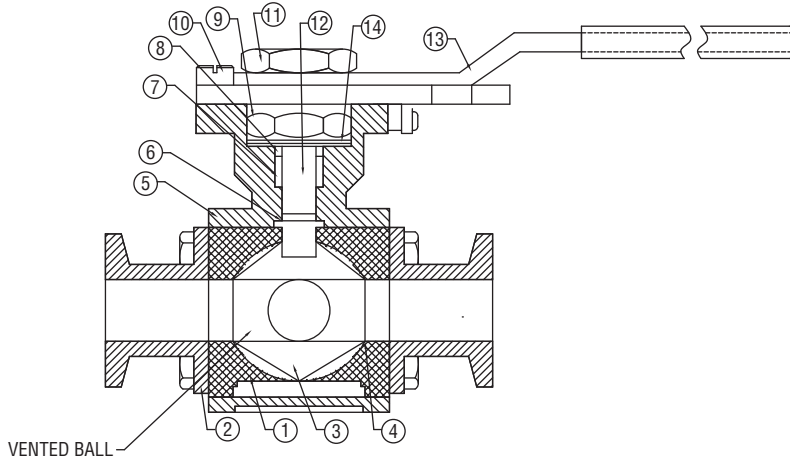

Item	Description	Material
1	Body	
2	Cap	ASTM A351-CF8M
3	Ball	
4	Ball Seat	
5	Gasket	PTFE
6	Thrust Washer	
7	Stem Packing	PTFE
8	Ring	AISI 304
9	Bevel Washer	AISI 301
10	Stop Pin	AISI 316
11	Nut	AISI 304
12	Stem	AISI 316
13	Handle	AISI 304
14	Prevailing Device	

**VALVE DIMENSIONAL DRAWING**

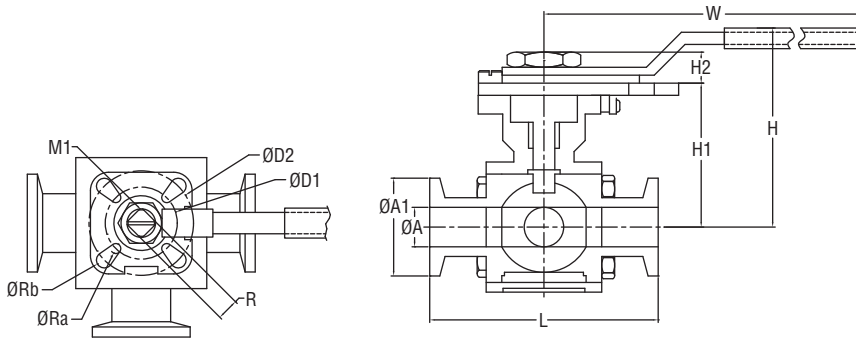

Model Number	Size	ØA	ØA1 in(mm)	ØD1 in(mm)	ØD2 in(mm)	ISO	S in(mm)	ØRa in(mm)	ØRb in(mm)	L in(mm)	W in(mm)	H in(mm)	H1 in(mm)	H2 in(mm)	Port	M1	Cv (gal/min)
WE33-CHD00-L	1/2"	3/8" (9.4)	1" (25.4)	1-27/64" (36)	1-21/32" (42)	F03/04	23/64" (9)	7/64" (2.75)	7/64" (2.75)	4-1/32" (118)	4-49/64" (122)	3-5/64" (78)	23/64" (9)	1-3/4" (44.50)	L	M12x1.75	14.39
WE33-DHD00-L	3/4"	5/8" (15.8)	1" (25.4)	1-27/64" (36)	1-21/32" (42)	F03/04	23/64" (9)	1/8" (3)	1/8" (3)	5" (127)	4-49/64" (122)	3-15/64" (82)	23/64" (9)	1-57/64" (48)	L	M12x1.75	42.25
WE33-EHD00-L	1"	7/8" (22.1)	1-63/64" (50.4)	1-27/64" (36)	1-21/32" (42)	F03/04	7/16" (11)	9/64" (3.5)	9/64" (3.5)	6" (152.4)	5-13/32" (137)	3-35/64" (90)	7/16" (11)	3-15/64" (59)	L	M14x2.0	86.17
WE33-GHD00-L	1-1/2"	1-26/64" (35)	1-63/64" (50.4)	1-31/32" (50)	2-3/4" (70)	F05/07	9/16" (14)	9/64" (3.5)	3/16" (4.5)	6-57/64" (175)	7-11/64" (183)	4-11/32" (110)	9/16" (14)	2-27/32" (72)	L	M18x2.5	223.61
WE33-HHD00-L	2"	1-7/8" (47.6)	2-33/64" (63.9)	1-31/32" (50)	2-3/4" (70)	F05/07	9/16" (14)	9/64" (3.5)	3/16" (4.5)	7-1/2" (190)	7-11/64" (183)	4-33/64" (114.7)	9/16" (14)	3-15/64" (59)	L	M18x2.5	437.98
WE33-CHD00-T	1/2"	3/8" (9.4)	1" (25.4)	1-27/64" (36)	1-21/32" (42)	F03/04	23/64" (9)	7/64" (2.75)	7/64" (2.75)	4-21/32" (118)	4-49/64" (122)	3-5/64" (78)	23/64" (9)	1-3/4" (44.50)	T	M12x1.75	14.39
WE33-DHD00-T	3/4"	5/8" (15.8)	1" (25.4)	1-27/64" (36)	1-21/32" (42)	F03/04	23/64" (9)	1/8" (3)	1/8" (3)	5" (127)	4-49/64" (122)	3-15/64" (82)	23/64" (9)	1-57/64" (48)	T	M12x1.75	42.25
WE33-EHD00-T	1"	7/8" (22.1)	1-63/64" (50.4)	1-27/64" (36)	1-21/32" (42)	F03/04	7/16" (11)	9/64" (3.5)	9/64" (3.5)	6" (152.4)	5-13/32" (137)	3-35/64" (90)	7/16" (11)	3-15/64" (59)	T	M14x2.0	86.17
WE33-GHD00-T	1-1/2"	1-26/64" (35)	1-63/64" (50.4)	1-31/32" (50)	2-3/4" (70)	F05/07	9/16" (14)	9/64" (3.5)	3/16" (4.5)	6-57/64" (175)	7-11/64" (183)	4-11/32" (110)	9/16" (14)	2-27/32" (72)	T	M18x2.5	223.61
WE33-HHD00-T	2"	1-7/8" (47.6)	2-33/64" (63.9)	1-31/32" (50)	2-3/4" (70)	F05/07	9/16" (14)	9/64" (3.5)	3/16" (4.5)	7-1/2" (190)	7-11/64" (183)	4-33/64" (114.7)	9/16" (14)	3-15/64" (59)	T	M18x2.5	437.98

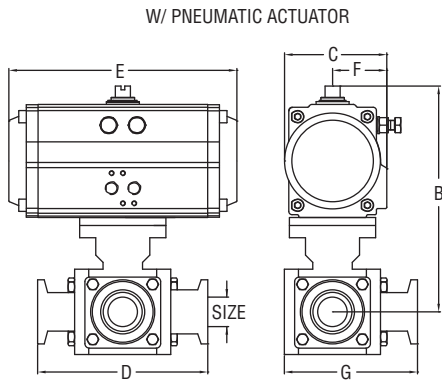

**Double Acting Pneumatic Actuator**

Size	1/2"	3/4"	1"	1-1/2"	2"
<b>B</b>	4-7/8" 124.5 mm	5" 128 mm	6" 151 mm	6-1/2" 164 mm	7-1/2" 190 mm
<b>C</b>	2-3/8" 60.5 mm	2-3/8" 60.5 mm	2-3/4" 71 mm	2-3/4" 71 mm	3-1/4" 82 mm
<b>D</b>	4-5/8" 118 mm	5" 127 mm	6" 152.4 mm	6-7/8" 175 mm	7-1/2" 190 mm
<b>E</b>	4-1/2" 116 mm	4-1/2" 116 mm	5-3/4" 145 mm	5-3/4" 145 mm	6-5/8" 169 mm
<b>F</b>	1-3/8" 36.5 mm	1-3/8" 36.5 mm	1-5/8" 41 mm	1-5/8" 41 mm	1-7/8" 46 mm
<b>G</b>	3-5/8" 91.6 mm	3-7/8" 98.6 mm	4-5/8" 117.8 mm	5-1/2" 139.6 mm	6-3/8" 160.6 mm

**Spring Return Pneumatic Actuator**

Size	1/2"	3/4"	1"	1-1/2"	2"
<b>B</b>	5-3/8" 136.5 mm	5-1/2" 140 mm	6-5/8" 167 mm	7-1/8" 180 mm	8-1/8" 208 mm
<b>C</b>	2-3/4" 71 mm	2-3/4" 71 mm	3-1/4" 82 mm	3-1/4" 71 mm	3-3/4" 94 mm
<b>D</b>	4-5/8" 118 mm	5" 127 mm	6" 152.4 mm	6-7/8" 175 mm	7-1/2" 190 mm
<b>E</b>	5-3/4" 145 mm	5-3/4" 145 mm	6-5/8" 169 mm	6-5/8" 169 mm	7-7/8" 201 mm
<b>F</b>	1-5/8" 41 mm	1-5/8" 41 mm	1-7/8" 46 mm	1-7/8" 46 mm	2" 52 mm
<b>G</b>	3-5/8" 91.6 mm	3-7/8" 98.6 mm	4-5/8" 117.8 mm	5-1/2" 139.6 mm	6-3/8" 160.6 mm

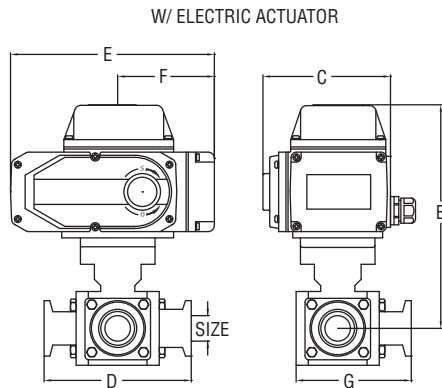

Size	1/2"	3/4"	1"	1-1/2"	2"
<b>B</b>	5-3/4" 147 mm	5-7/8" 150.5 mm	6-3/8" 161.5 mm	6-7/8" 174.5 mm	7-1/4" 184.5 mm
<b>C</b>	4-1/2" 113 mm	4-1/2" 113 mm	4-1/2" 113 mm	4-1/2" 113 mm	4-1/2" 113 mm
<b>D</b>	4-5/8" 118 mm	5" 127 mm	6" 152.4 mm	6-7/8" 175 mm	7-1/2" 190 mm
<b>E</b>	6-1/4" 160 mm	6-1/4" 160 mm	6-1/4" 160 mm	6-1/4" 160 mm	6-1/4" 160 mm
<b>F</b>	3" 77 mm	3" 77 mm	3" 77 mm	3" 77 mm	3" 77 mm
<b>G</b>	3-5/8" 91.6 mm	3-7/8" 98.6 mm	4-5/8" 117.8 mm	5-1/2" 139.6 mm	6-3/8" 160.6 mm

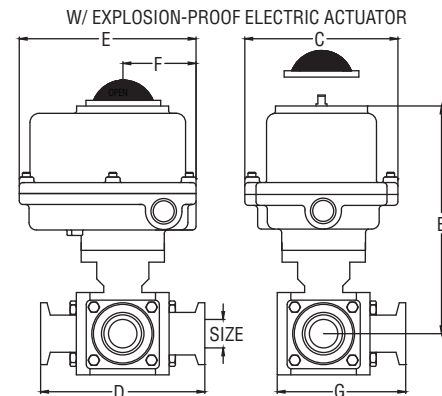

NPT	1/2"	3/4"	1"	1-1/2"	2"
<b>B</b>	8-1/8" 207 mm	8-1/4" 210 mm	8-3/4" 221.3 mm	9-1/4" 234.3 mm	9-5/8" 244.3 mm
<b>C</b>	9-3/8" 238.9 mm	9-3/8" 238.9 mm	9-3/8" 238.9 mm	9-3/8" 238.9 mm	9-3/8" 238.9 mm
<b>D</b>	4-5/8" 118 mm	5" 127 mm	6" 152.4 mm	6-7/8" 175 mm	7-1/2" 190 mm
<b>E</b>	8-1/2" 216.7 mm	8-1/2" 216.7 mm	8-1/2" 216.7 mm	8-1/2" 216.7 mm	8-1/2" 216 mm
<b>F</b>	5" 125.8 mm	5" 125.8 mm	5" 125.8 mm	5" 125.8 mm	5" 125.8 mm
<b>G</b>	3-5/8" 91.6 mm	3-7/8" 98.6 mm	4-5/8" 117.8 mm	5-1/2" 139.6 mm	6-3/8" 160.6 mm

**PNEUMATIC ACTUATOR**

Note: For optimal operation, pneumatic actuators should be run with a supply of clean, lubricated air.

**Spring Return Actuator Operation**

Air to PORT 2 (the left hand port) causes the actuator to turn counter clockwise (CCW). Loss of air to PORT 2 causes air to exhaust and the actuator turns clockwise (CW). This is the FAIL CLOSE operation.

**Double Acting Actuators Operation**

Air to PORT 2 (the left hand port) causes the actuator to turn counter clockwise (CCW). Air to PORT 1 (the right hand port) causes the actuator to turn clockwise (CW).

**Pneumatic Actuator Maintenance**

Routine maintenance of pneumatic actuator:

- Keep the air supply dry and clean
- Keep the actuator surface clean and free from dust
- Periodic checks should be done to make sure all fittings are tight
- Pneumatic actuators are supplied with lubrication to last the entire life span of the actuator under normal operating conditions.

The outer surface of the pneumatic actuator should be clean to avoid friction or corrosion. All fittings and connections should be tight to prevent leaks during operation. Check the bolts mounting the valve to the actuator to make sure they have not come loose during shipping or installation. Make sure the valve and actuator are not rubbing or jamming against other components during operation. The actuator should be inspected annually to make sure all fittings and bolts are tight and nothing has come loose during operation.

**Disassembling Pneumatic Actuators**

**WARNING** Before beginning disassembly, ensure that the air supply to the actuator has been disconnected, all accessories have been removed, and that the actuator has been disassembled from the valve.

1. Loosen the end cap fasteners (22) with a wrench (size varies depending on actuator model). On the spring return actuator, alternate 3 to 5 turns on each fastener until the springs are completely decompressed. Use caution when removing the cap since the springs are under load until the fasteners are fully extended.
2. Remove the pinion snap ring (10) with a lock ring tool. The indicator (7) may now be removed.
3. Turn the pinion shaft (2) counter clockwise until the pistons are at the full end of travel. Disengage the pistons (11) from the pinion. (NOTE: Low pressure air--3 to 5 psi MAXIMUM--might be required to force the pistons completely from the body.) Note the position of the pistons before removing them from the actuator body.
4. Remove the pinion through the bottom of the actuator. The actuator is now completely disassembled.

**Pneumatic Actuators Bill of Materials**

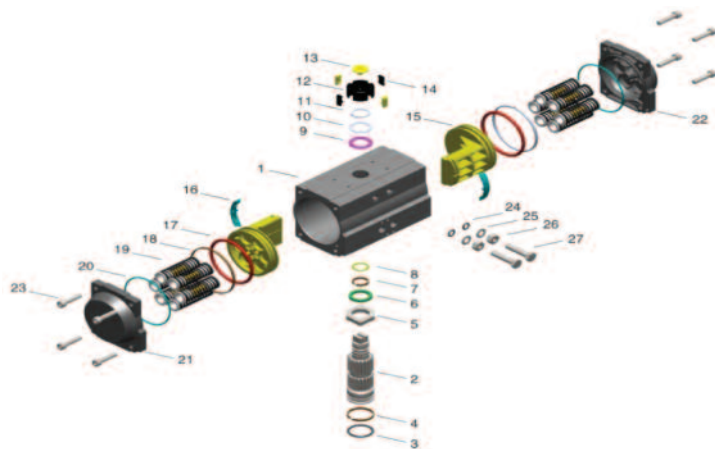

Failures	Inspection Items	Corrective Action
<b>Pneumatic actuator won't operate</b>	1. Check the solenoid valve. Is the coil burnt out or is the solenoid spool?	1. Replace the solenoid valve coil or remove debris.
	2. The actuator will not move because of debris in the gears.	2. Disassemble the actuator, clean the debris and reassemble the actuator.
	3. The pneumatic line to the actuator is distorted or smashed.	3. Replace pneumatic line to the actuator.
	4. The pneumatic line is frozen because of low temperatures and moisture.	4. Warm the pneumatic lines and remove moisture from supply lines.
<b>Pneumatic actuator runs slowly</b>	1. The air supply pressure is insufficient.	1. Increase the air supply pressure and look for leaks in the supply pressure pipeline.
	2. Are other pneumatic devices consuming the air required for the actuator to operate?	2. Increase the air supply or reduce the number of devices operating at the same time.
	3. The pneumatic actuator is undersized for the application.	3. Replace the actuator with a larger actuator.

**Reassembling Pneumatic Actuators**

**WARNING** Be sure the actuator surfaces are free of debris and scratches before reassembling.

1. Apply a light film of grease to all O-rings and the pinion before replacing.
2. Put the pinion (2) back through the actuator with the flats of the pinion shaft running parallel with the body.
3. When reassembling the actuator, make sure that the piston racks are square to the actuator body and returned to their original orientation. (NOTE: The normal operation of all spring return pneumatic actuators is FAIL CLOSED. To change the orientation to FAIL OPEN, rotate the racks 180° to create a reverse operation.
4. When replacing springs in a spring return actuator, ensure that the springs are replaced in their identical position in the end cap from which they were removed. (NOTE: In some circumstances, you might want to change the standard 80 pound spring set to fit your application and available air pressure.
5. Seal the end caps with a petroleum lubricant and bolt to actuator body.
6. Check the seal of the actuator by covering seal areas (pinion, end caps) with soapy water and using low pressure air to the actuator to ensure that no bubbles are produced.

Part Number	Quantity	Part Name	Material
1	1	Cylinder	Extruded Aluminum Alloy
2	1	Output Shaft	Stainless Steel
3	1	O-ring	Fluorine Silicon Rubber
4	1	Bearing	Nylon46
5	1	Adjusting Cam	Stainless Steel
6	1	Thrust Bearing	Nylon46
7	1	Bearing	Nylon46
8	1	O-ring	Fluorine Silicon Rubber
9	1	Bearing	Nylon46
10	1	Gasket	Stainless Steel
11	1	Damping Ring	Stainless Steel
12	1	Position Indicator	PPPP+30%GF
13	1	Screw	PPPP+30%GF
14	4	Position Indicating Inserts	PPPP+30%GF
15	2	Piston	Casting Aluminum Alloy
16	2	Guide Ring	Nylon46
17	2	O-ring	Fluorine Silicon Rubber
18	2	Guide Ring	Fluorine-Carbon Composite Material
19	5 to 12	Spring Assembly	Alloy Spring Steel
20	2	O-ring	Fluorine Silicon Rubber
21	1	Left End Cap	Casting Aluminum Alloy
22	1	Right End Cap	Casting Aluminum Alloy
23	8	End Cap Bolt	Stainless Steel
24	2	O-ring	Fluorine Silicon Rubber
25	2	Gasket	Stainless Steel
26	2	Nut	Stainless Steel
27	2	Adjusting Bolt	Stainless Steel

## Double Acting Actuator Torque

Model	DA Double-Action Output Torque (lb-in)									
	Air Pressure									
	40 psi	50 psi	60 psi	70 psi	80 psi	90 psi	100 psi	110 psi	115 psi	
ACT-DA01	49	61	74	86	98	110	123	135	142	
ACT-DA02	104	130	155	181	207	233	259	285	300	
ACT-DA03	182	228	274	319	365	411	456	502	529	
ACT-DA04	302	377	453	528	603	679	754	830	875	
ACT-DA05	396	495	594	693	792	891	990	1089	1148	
ACT-DA06	567	709	851	993	1135	1277	1419	1561	1649	
ACT-DA07	845	1056	1267	1478	1690	1901	2112	2323	2450	
ACT-DA08	1497	1871	2245	2619	2993	3367	3742	4116	4340	
ACT-DA09	2253	2816	3379	3942	4506	5069	5632	6195	6533	

## Spring Return Actuator Torque

Model	Spring Quantity	SR Single Acting Pneumatic Actuator (lb-in)													
		Air Pressure													
		70 psi		80 psi		90 psi		100 psi		110 psi		115 psi		Spring Torque	
		0° Start	90° End	0° Start	90° End	0° Start	90° End	0° Start	90° End	0° Start	90° End	0° Start	90° End	90° Start	0° End
ACT-SR02	10	111	86	137	112	163	138	189	164	215	189	231	205	96	70
ACT-SR03	10	199	143	245	189	291	235	336	280	382	326	409	353	176	120
ACT-SR04	10	348	254	424	330	499	405	575	481	650	556	695	601	274	180
ACT-SR05	10	430	312	529	411	628	510	727	609	826	708	885	767	381	263
ACT-SR06	10	608	458	750	599	891	741	1033	883	1175	1025	1260	1110	536	386
ACT-SR07	10	783	663	994	874	1206	1085	1417	1297	1628	1508	1755	1635	817	696
ACT-SR08	10	1682	1208	2056	1583	2430	1957	2804	2331	3178	2705	3403	2930	1416	938
ACT-SR09	10	2303	1483	2866	2046	3429	2609	3992	3173	4556	3736	4894	4074	2363	1575
ACT-SR10	10	3479	2274	4337	3133	5195	3991	6053	4849	6911	5707	7426	6222	3549	2407

## ELECTRIC ACTUATORS

### Electric Installation

- Operate valve manually and place in the open position.
- Remove any mechanical stops the valve might have. (DO NOT REMOVE ANY PARTS NECESSARY FOR THE PROPER OPERATION OF THE VALVE, SUCH AS THE PACKING GLAND, PACKING NUT, ETC.)
- Ensure that the actuator output shaft and valve stem are aligned properly. If they are not, operate the valve manually until they are correct.
- Remove actuator cover.
- Bring power to the actuator. CAUTION: Make sure power is OFF at the main box.
- Wire the actuator per the diagram attached to the inside of the cover. Special actuators (those with positioner boards, etc.) will have diagrams enclosed inside the cover.
- Securely tighten bolts used to mount the actuator to a mounting bracket or directly to the valve mounting pad if it is ISO5211 compliant.
- Cycle the unit several times and check the open and closed positions of the valve. Cams are pre-adjusted at the factory; due to the variety of valve designs and types however, slight adjustments might be required.
- Replace cover and tighten screws.

### To Set The Open Position

- Cycle the valve to the open position by applying power to terminals. The top cam and switch control this position. In the open position, the set screw in the top cam will be accessible.
- If the valve is not open completely:
  - Slightly loosen the set screw on the top cam.
  - Rotate the cam clockwise (CW) by hand until the switch makes contact. Contact is made when a slight click can be heard. By making incremental CW movements of the top cam, the valve can be positioned precisely in the desired position.
  - When the top cam is set, tighten the set screw securely.
- If the valve opens too far:
  - Apply power to terminals. This will begin to rotate valve CW. When valve is fully open and in the exact position desired, remove power from actuator.
  - Loosen the set screw in the top cam.
  - Rotate the top cam counterclockwise (CCW) until the switch arm drops off the round portion of the cam onto the flat section. A slight click can be heard as the switch changes state.
  - Continue applying power to terminals until valve is in the desired position.

### To Set The Closed Position

- Apply power to terminals to move the valve toward the closed position. The bottom cam and switch control the closed position. In the closed position, the set screw in the bottom cam will be accessible.
- If the valve is not closed completely:
  - Slightly loosen the set screw on the bottom cam.
  - Rotate the cam counter-clockwise (CCW) by hand until the switch makes contact. Contact is made when a slight click can be heard. By making incremental CCW movements of the bottom cam, the valve can be positioned precisely in the desired position.
  - When the top cam is set, tighten the set screw securely.
- If the valve closes too far:
  - Apply power to terminals. This will begin to rotate valve CCW. When valve is fully closed and in the exact position desired, remove power from actuator.
  - Loosen the set screw in the top cam.
  - Rotate the top cam clockwise (CW) until the switch arm drops off the round portion of the cam onto the flat section. A slight click can be heard as the switch is no longer making contact with the round part of the cam.
  - Continue applying power to terminals until valve is in the desired position.

Wiring Diagrams for  
 TI01-TI10: 120 VAC, TI01-TI10: 220VAC, TI01-TI10: 24 VAC

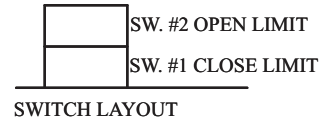
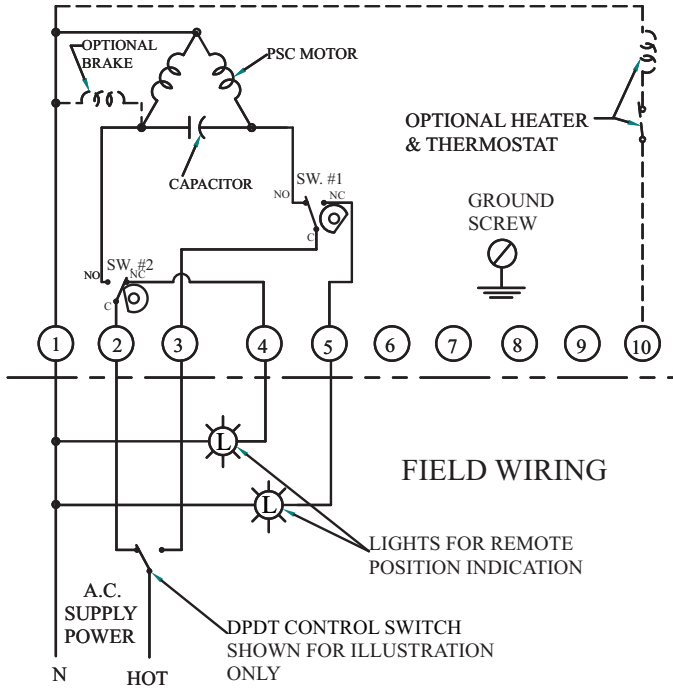

NOTES:  
 POWER TO TERMINALS ONE & TWO OPENS THE VALVE (CCW ROTATION)  
 POWER TO TERMINALS ONE & THREE CLOSSES THE VALVE (CW ROTATION)  
 TERMINALS 4 & 5 ARE FOR LIGHT INDICATION  
 WIRING DIAGRAM ILLUSTRATES THE ACTUATOR IN THE OPEN POSITION

----- OPTIONAL EQUIPMENT  
 \_\_\_\_\_ FIELD WIRING

Wiring Diagrams for  
 TI01-TI10: 12VDC, TI01-TI10: 24 VDC

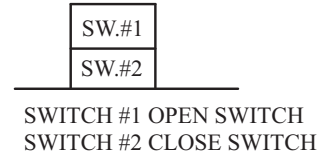
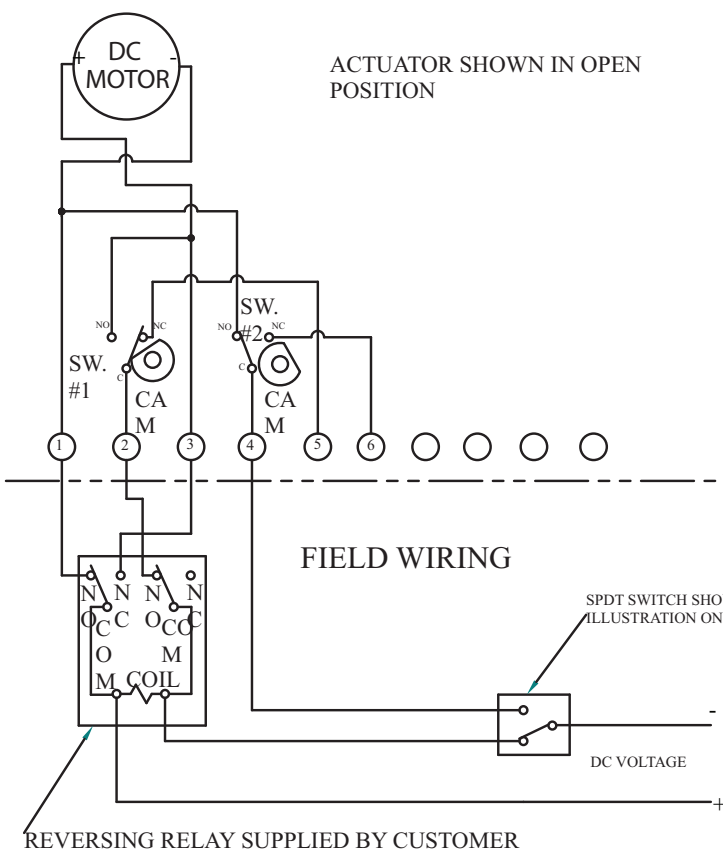

OPERATION:  
 POWER TO 1 & 2 FOR CCW ROTATION  
 POWER TO 3 & 4 FOR CW ROTATION  
 TERMINALS 5 & 6 FOR FIELD LIGHT INDICATION CONNECTION

REVERSING RELAY SUPPLIED BY CUSTOMER

**Wiring Diagrams for  
MI01-MI10: 120 VAC, MI01-MI10: 220 VAC, MI01-MI10: 24 VAC**

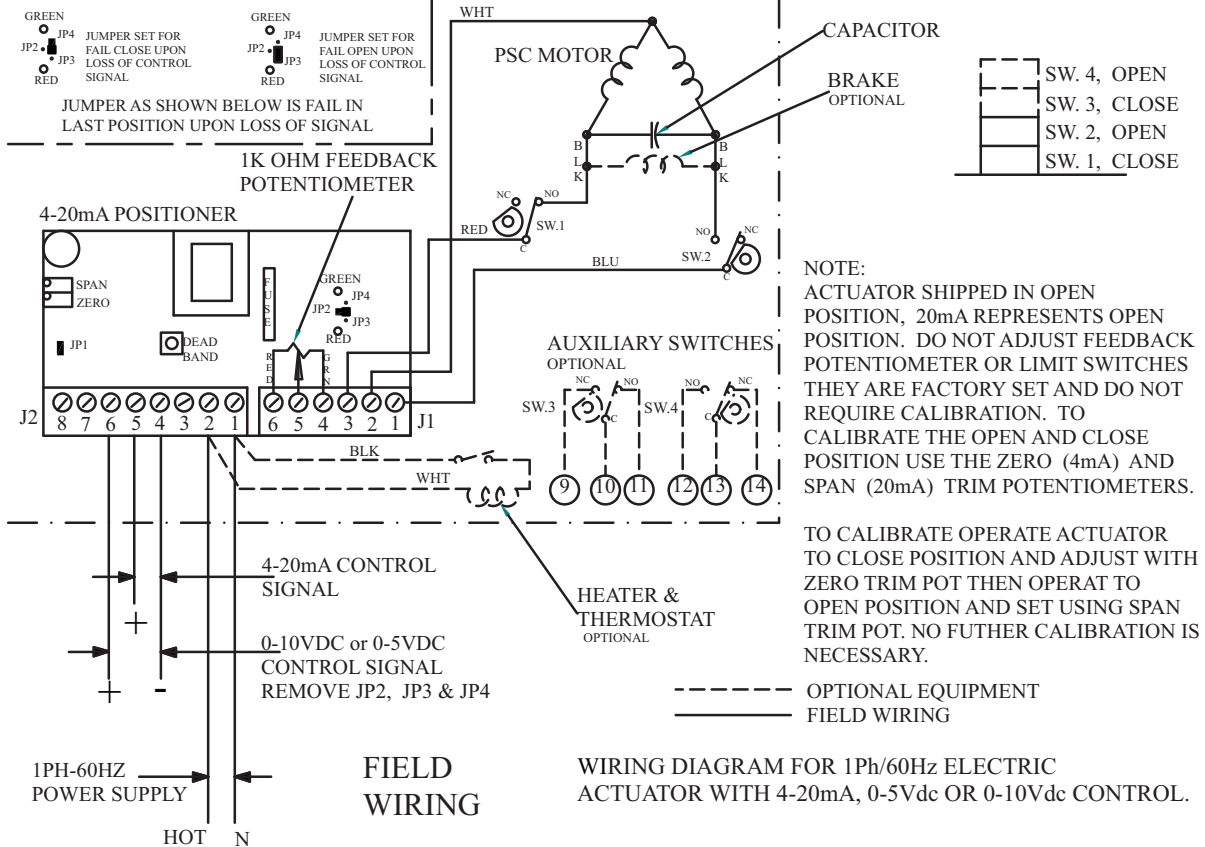

**Wiring Diagrams for  
MI01-MI10: 12 VDC, MI01-MI10: 24 VDC**

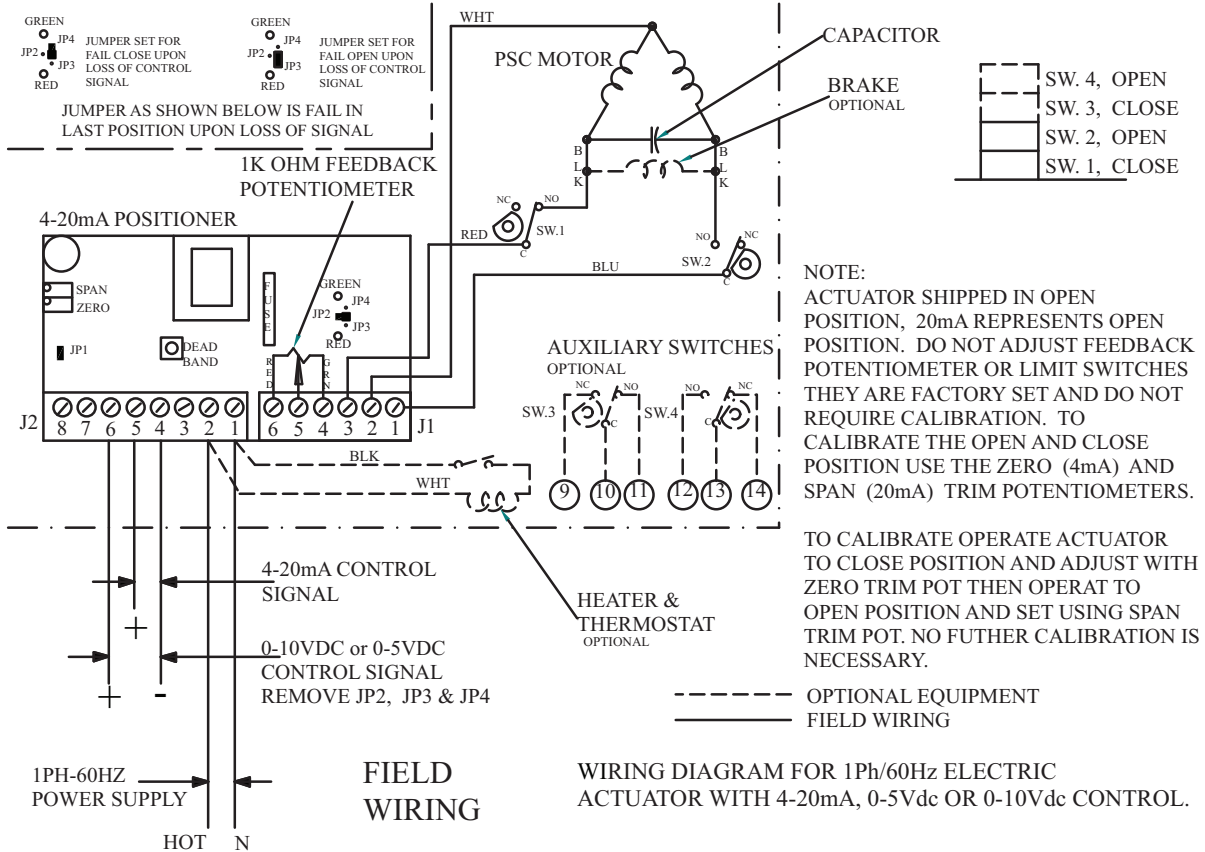

**Electric Actuators Wiring Diagram: ACT-TD & ACT-MD**

Wiring Diagrams for  
 TD01-TD09: 120 VAC, TD01-TD09: 220 VAC, TD01-TD09: 24 VAC

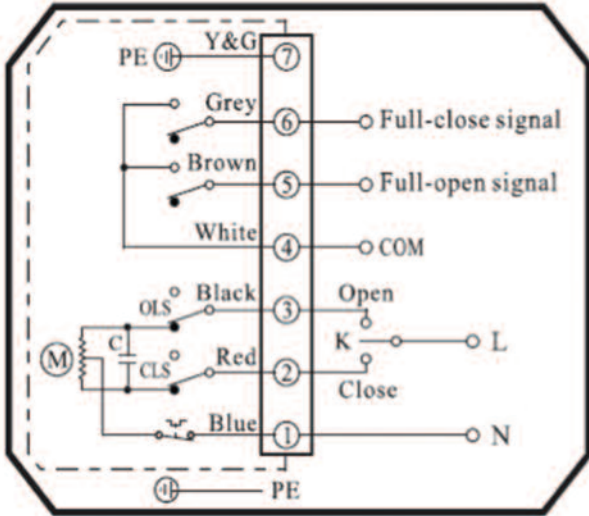

Wiring Diagrams for  
 TD01-TD06: 24 VDC

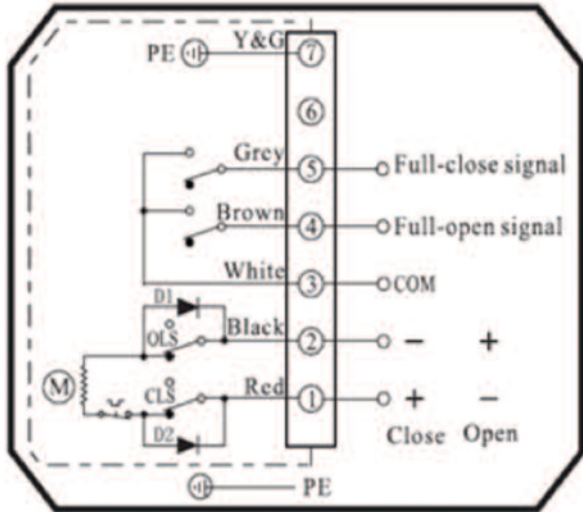

Wiring Diagrams for  
 MD01-MD09: 120 VAC, MD01-MD09: 220 VAC, MD01-MD09: 24 VAC

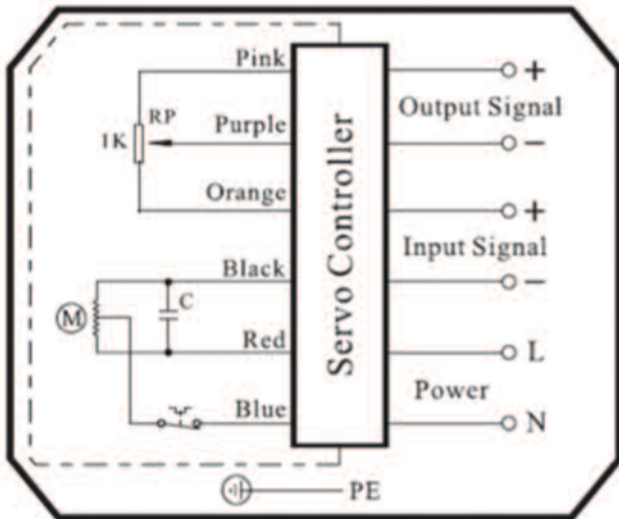

**Note:** To speed up installation of the control wires to the ACT-MDXX modulating actuator, it is recommended to remove the control module from the actuator. The control module can be removed by removing the two mounting screws on the left and right of the control module. Install the control wires to the correct terminal points and then reinstall the control module.

**Electric Actuator Maintenance**

Once the actuator has been properly installed, it requires no maintenance. The gear train has been lubricated and in most cases will never be opened.

**Duty Cycle Definition**

"Duty Cycle" means the starting frequency.

Formula:  $\text{Running Time} \div (\text{Running Time} \div \text{Rest Time}) \times 100\% = \text{duty cycle}$

→  $\text{Rest Time} = \text{Running Time} \times (1 - \text{duty cycle}) \div \text{duty cycle}$

For example: The running time is 15 seconds

30% duty cycle  $15 \times [(1 - 30\%) / 30\%] = 35$  → The rest time will be 35 seconds

75% duty cycle  $15 \times [(1 - 75\%) / 75\%] = 5$  → The rest time will be 5 seconds

If the duty cycle is higher, the rest time will be shortened. It means the starting frequency will be higher.

**Thermal Overload**

All actuators are equipped with thermal overload protection to guard the motor against damage due to overheating.

**Mechanical Overload**

All actuators are designed to withstand stall conditions. It is not recommended to subject the unit to repeated stall conditions.

**Explosion-Proof Electric Actuators**



1. DO NOT under any circumstances remove the cover of the actuator while in a hazardous location. Removal of the cover while in a hazardous location could cause ignition of hazardous atmospheres.
2. DO NOT under any circumstances use an explosion-proof electric actuator in a hazardous location that does not meet the specifications for which the actuator was designed.
3. Always verify that all electrical circuits are de-energized before opening the actuator.
4. Always mount and cycle test the actuator on the valve in a non-hazardous location.
5. When removing the cover, care must be taken not to scratch, scar or deform the flame path of the cover and base of the actuator, since this will negate the NEMA rating of the enclosure.
6. When replacing the cover, take care that the gasket is in place to assure proper clearance after the cover is secured.
7. All electrical connections must be in accordance with the specifications for which the unit is being used.
8. Should the unit ever require maintenance, remove from the hazardous location before attempting to work on the unit.

If the actuator is in a critical application, it is advisable to have a standby unit in stock.



**Electric Actuators Performance Rating**

<b>TD01</b>				
Voltage	110 VAC	220 VAC	24 VAC	24 VDC
Cycle Time	4 s	4 s	4 s	4 s
Duty Cycle (Two-Position)	85%	85%	85%	85%
AMP Draw	0.24 A	0.16 A	0.28 A	1.28 A
Torque	177 in-lb	177 in-lb	177 in-lb	177 in-lb

<b>MD01</b>				
Voltage	110 VAC	220 VAC	24 VAC	24 VDC
Cycle Time	10 s	10 s	10 s	10 s
MD01 Duty Cycle (Modulating)	85%	85%	85%	85%
AMP Draw	0.24 A	0.16 A	1.28 A	
Torque	265 in-lb	265 in-lb	265 in-lb	

<b>TD02 and MD02 (MD Not Available in 24 VDC)</b>				
Voltage	110 VAC	220 VAC	24 VAC	24 VDC
Cycle Time	20 s	20 s	20 s	20 s
Duty Cycle (Two-Position)	85%	85%	85%	85%
Duty Cycle (Modulating)	85%	85%	85%	85%
AMP Draw	0.24 A	0.16 A	1.28 A	1.28 A
Torque	442 in-lb	442 in-lb	442 in-lb	442 in-lb

<b>TD03 and MD03 (MD Not Available in 24 VDC)</b>				
Voltage	110 VAC	220 VAC	24 VAC	24 VDC
Cycle Time	30 s	30 s	30 s	30 s
Duty Cycle (Two-Position)	85%	85%	85%	85%
Duty Cycle (Modulating)	85%	85%	85%	85%
AMP Draw	0.57 A	0.35 A	2.03 A	2.03 A
Torque	885 in-lb	885 in-lb	885 in-lb	885 in-lb

<b>TD04 and MD04 (MD Not Available in 24 VDC)</b>				
Voltage	110 VAC	220 VAC	24 VAC	24 VDC
Cycle Time	30 s	30 s	30 s	30 s
Duty Cycle (Two-Position)	85%	85%	85%	85%
Duty Cycle (Modulating)	85%	85%	85%	85%
AMP Draw	0.65 A	0.37 A	3.57 A	3.57 A
Torque	1770 in-lb	1770 in-lb	1770 in-lb	1770 in-lb

<b>TD05 and MD05 (MD Not Available in 24 VDC)</b>				
Voltage	110 VAC	220 VAC	24 VAC	24 VDC
Cycle Time	30 s	30 s	30 s	30 s
Duty Cycle (Two-Position)	85%	85%	85%	85%
Duty Cycle (Modulating)	85%	85%	85%	85%
AMP Draw	1.12 A	0.57 A	5.13 A	5.13 A
Torque	3540 in-lb	3540 in-lb	3540 in-lb	3540 in-lb

<b>TD06 and MD06 (MD Not Available in 24 VDC)</b>				
Voltage	110 VAC	220 VAC	24 VAC	24 VDC
Cycle Time	45 s	45 s	45 s	45 s
Duty Cycle (Two-Position)	85%	85%	85%	85%
Duty Cycle (Modulating)	85%	85%	85%	85%
AMP Draw	1.18 A	0.60 A	6.04 A	6.04 A
Torque	5210 in-lb	5210 in-lb	5210 in-lb	5210 in-lb

<b>TI01 and MI01</b>				
Voltage	110 VAC	220 VAC	24 VAC	24 VDC
Cycle Time	2.5 s	2.5 s	2.5 s	2.5 s
Duty Cycle (Two-Position)	25%	25%	25%	25%
Duty Cycle (Modulating)	75%	75%	75%	75%
AMP Draw	0.55 A	0.38 A	2.44 A	2.44 A
Torque	100 in-lb	100 in-lb	100 in-lb	100 in-lb

<b>TI02 and MI02</b>				
Voltage	110 VAC	220 VAC	24 VAC	24 VDC
Cycle Time	5 s	5 s	5 s	5 s
TI01 Duty Cycle (Two-Position)	25%	25%	25%	25%
MI01 Duty Cycle (Modulating)	75%	75%	75%	75%
AMP Draw	0.75 A	0.38 A	3.2 A	3.2 A
Torque	200 in-lb	200 in-lb	200 in-lb	200 in-lb

<b>TI03 and MI03</b>				
Voltage	110 VAC	220 VAC	24 VAC	24 VDC
Cycle Time	5 s	5 s	5 s	5 s
Duty Cycle (Two-Position)	25%	25%	25%	25%
Duty Cycle (Modulating)	75%	75%	75%	75%
AMP Draw	0.75 A	0.38 A	3.2 A	3.2 A
Torque	300 in-lb	300 in-lb	300 in-lb	300 in-lb

<b>TI04 and MI04</b>				
Voltage	110 VAC	220 VAC	24 VAC	24 VDC
Cycle Time	10 s	10 s	10 s	10 s
Duty Cycle (Two-Position)	25%	25%	25%	25%
Duty Cycle (Modulating)	75%	75%	75%	75%
AMP Draw	0.75 A	0.38 A	3.2 A	3.2 A
Torque	400 in-lb	400 in-lb	400 in-lb	400 in-lb

<b>TI05 and MI05</b>				
Voltage	110 VAC	220 VAC	24 VAC	24 VDC
Cycle Time	15 s	15 s	15 s	15 s
Duty Cycle (Two-Position)	25%	25%	25%	25%
Duty Cycle (Modulating)	75%	75%	75%	75%
AMP Draw	0.75 A	0.38 A	3.2 A	3.2 A
Torque	625 in-lb	625 in-lb	625 in-lb	625 in-lb

<b>TI06 and MI06</b>				
Voltage	110 VAC	220 VAC	24 VAC	24 VDC
Cycle Time	15 s	15 s	15 s	15 s
Duty Cycle (Two-Position)	25%	25%	25%	25%
Duty Cycle (Modulating)	75%	75%	75%	75%
AMP Draw	1.1 A	0.38 A	3.2 A	3.2 A
Torque	1000 in-lb	1000 in-lb	1000 in-lb	1000 in-lb

<b>TI07 and MI07</b>				
Voltage	110 VAC	220 VAC	24 VAC	24 VDC
Cycle Time	30 s	30 s	30 s	30 s
Duty Cycle (Two-Position)	25%	25%	25%	25%
Duty Cycle (Modulating)	75%	75%	75%	75%
AMP Draw	1.1 A	0.38 A	3.2 A	3.2 A
Torque	1500 in-lb	1500 in-lb	1500 in-lb	1500 in-lb

<b>TI08 and MI08</b>				
Voltage	110 VAC	220 VAC	24 VAC	24 VDC
Cycle Time	12 s	12 s	12 s	12 s
Duty Cycle (Two Position)	100%	100%	100%	100%
Duty Cycle (Modulating)	100%	100%	100%	100%
AMP Draw	2.6 A	2.4 A	20 A	20 A
Torque	2000 in-lb	2000 in-lb	2000 in-lb	2000 in-lb

<b>TI09 and MI09</b>				
Voltage	110 VAC	220 VAC	24 VAC	24 VDC
Cycle Time	14 s	14 s	14 s	14 s
Duty Cycle (Two-Position)	100%	100%	100%	100%
Duty Cycle (Modulating)	100%	100%	100%	100%
AMP Draw	2.99 A	2.4 A	20 A	20 A
Torque	3840 in-lb	3840 in-lb	3840 in-lb	3840 in-lb

<b>TI10 and MI10</b>				
Voltage	110 VAC	220 VAC	24 VAC	24 VDC
Cycle Time	68 s	68 s	68 s	68 s
Duty Cycle (Two-Position)	100%	100%	100%	100%
Duty Cycle (Modulating)	100%	100%	100%	100%
AMP Draw	2.99 A	2.4 A	20 A	20 A
Torque	5000 in-lb	5000 in-lb	5000 in-lb	5000 in-lb

**MAINTENANCE/REPAIR**

Upon final installation of the Series WE, only routine maintenance is required. The Series WE is not field serviceable and should be returned if repair is needed. Field repair should not be attempted and may void warranty.

**WARRANTY/RETURN**

Refer to "Terms and Conditions of Sale" in our catalog and on our website. Contact customer service to receive a Return Goods Authorization number before shipping the product back for repair. Be sure to include a brief description of the problem plus any additional application notes

