

## Installing the Sensor

**!WARNING!**

Before performing service or maintenance operations on the systems, turn OFF main power switches to the unit. Electric shock can cause personal injury. Please read and follow the wiring instructions precisely; miswiring may cause permanent damage to the product.

### Basic Installation for T8100-NS and NSP

1. Separate the case into its front and rear sections.
2. Secure the rear section of the case to the wall or junction box using the supplied screws, and make necessary wire connections.
3. Mount the Controller on the base by aligning the top clips and then securing to the bottom clips. Secure the Ventostat with the supplied set screw. A one-minute stabilization warmup will take place.

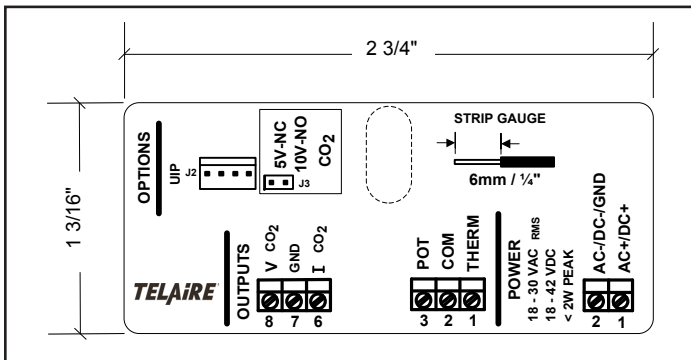
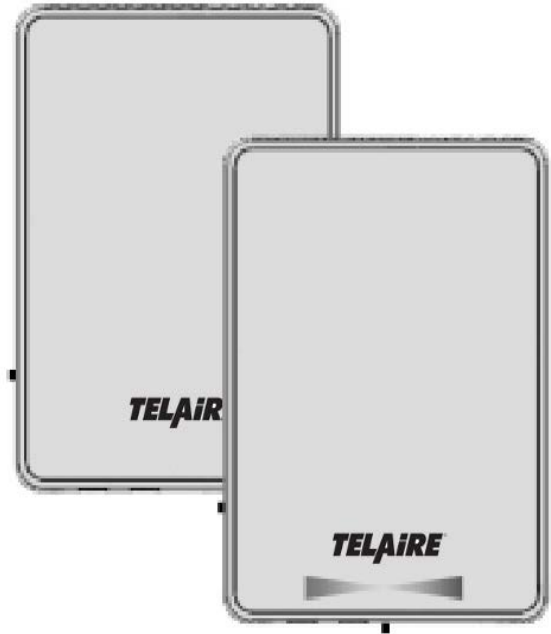

Internal Label

# T8100-NS/NSP Wiring Diagrams

The Ventostat T8100-NS and T8100-NSP family of products has two basic configurations.

T8100-NS provides simultaneous voltage and current outputs for CO<sub>2</sub>, an independent thermistor with Night Setback Override Button. The button shorts the thermistor when depressed.

T8100-NSP provides simultaneous voltage and current outputs for CO<sub>2</sub>, an independent thermistor with Night Setback Override Button and slide Potentiometer that can be used to control thermostat set point. The slide potentiometer has 0 KOhm value in the left position and 100 KOhm value in the right position; the middle position corresponds to 50 KOhm value.

The functional block diagram of T8100-NSP is presented in Figure 1.

*The electrical circuits of thermistor, Night Setback Overage Button and potentiometer have common signal between each other as shown in Figure 1.*

*The electrical circuits of the CO<sub>2</sub> sensor power supply and outputs, from one side and thermistor, Night Setback Override Button and Potentiometer from the other, are electrically isolated from each other.*

For electrical wiring and power supply requirements, these two configurations are identical. The recommended wire gauge is 18-22 AWG (1.0 to 0.75 metric).

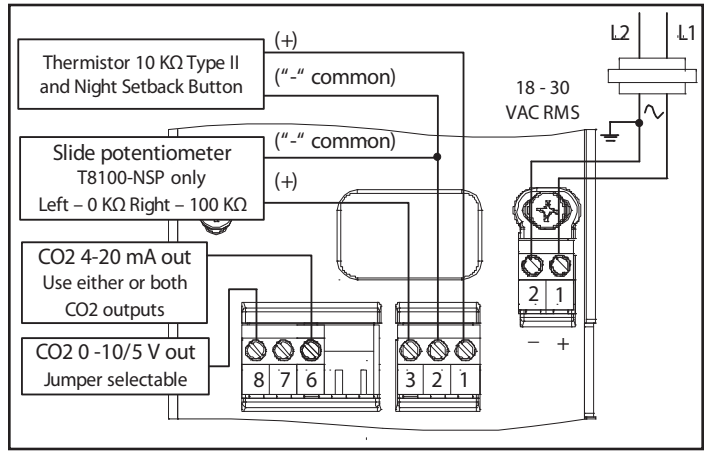

**Figure 2: T8100-NS/NSP Wiring for 3-Wire System, AC Power**

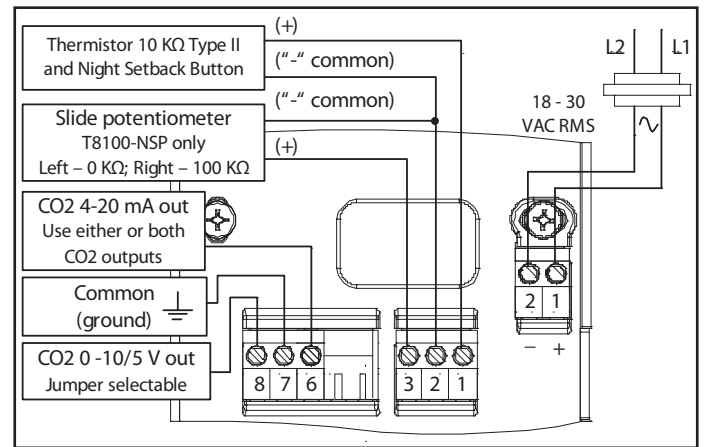

**Figure 3: T8100-NS/NSP Wiring for 4-Wire System, AC Power**

**!WARNING!**

**Ventostat T8100-NS/NSP products have two terminal pins that are connected inside the sensor to a common/ground: pin #7 on the I/O terminal blocks and pin #2 on the power block. Do NOT connect positive (hot) 24 VAC power line to terminal number 2 of the terminal block.**

**Caution!**

The T8100 Ventostats are either 3-wire or 4-wire type configurations, powered by either AC or DC voltage. They are not 2-wire or loop-powered devices. Wiring the units as 2-wire or loop-powered devices will irreparably damage the sensors and void the warranty.

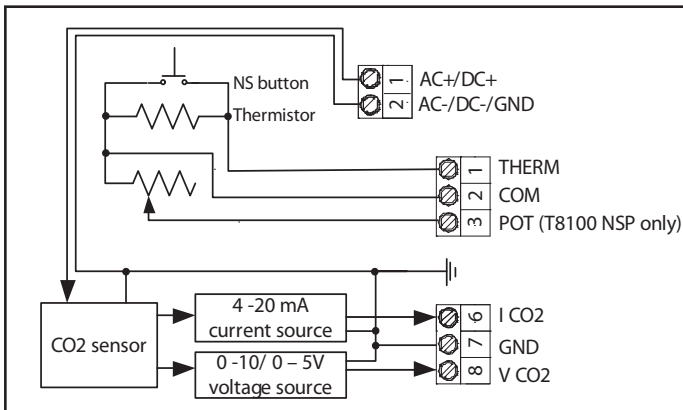

**Figure 1: T8100-NS/NSP Functional Block Diagram**

# Ventostat Specifications

## Sensing Method

Non-dispersive infrared (NDIR) absorption  
Gold-plated optics  
Patented ABC Logic self calibration algorithm

## CO<sub>2</sub> Measurement Range

T8100  
0 to 2000 ppm (0 ppm = 0 V, 4 mA; 2000 ppm = 10/5V, 20 mA)

## CO<sub>2</sub> Accuracy

T8100-NS or T8100-NSP- Single Channel  
400-1250 ppm  $\pm 30$  ppm or 3% of reading, whichever is greater\*,\*\*  
1250-5000 ppm  $\pm 5\%$  of reading + 30ppm \*, \*\*

\*Tolerance based on span gas of  $\pm 2\%$

\*\* ABC Logic not deactivated

## Power Supply Requirements

18-30 VAC RMS, 50/60 Hz, or 18 to 42 VDC, polarity protected

## Power Consumption

Typical 0.7 W at nominal voltage of 24V AC RMS

## Temperature Dependence

0.2% FS per °C ( $\pm 0.11\%$  per °F)

## Stability

<2% of FS over life of sensor (15 years)

## Pressure Dependence

0.135% of reading per mm Hg

## Certifications

CE and RoHS compliant

## Signal Update

Every 5 seconds

## CO<sub>2</sub> Warm-up Time

< 2 minutes (operational)  
10 minutes (maximum accuracy)

## Operating Conditions

32°F to 122°F (0°C to 50°C)  
0 to 95% RH, non-condensing

## Storage Conditions

-40°F to 158°F (-40°C to 70°C)

## Flammability Classification

UL94 5VA

## Thermistor Type

NTC 10 K  $\Omega$  thermistor

## Thermistor Accuracy

$\pm 1^\circ\text{C}$  (15° to 35°C)

## Night Setback Override Button (NS and NSP)

Shorts the thermistor output when depressed

## Slide Potentiometer (NSP Only)

Left (stop) 0k Ohms ( $\pm 5\text{k}\ \Omega$ )  
Center 50k Ohms ( $\pm 7.5\text{k}\ \Omega$ )  
Right (stop) 100k Ohms ( $\pm 15\text{k}\ \Omega$ )

## ABC Logic™ Self Calibration System

ABC Logic™ (Automatic Background Calibration) self calibration allows the sensor to continually recalibrate itself when the indoor concentrations drop to outside levels while the building is unoccupied. Generally a building must be regularly unoccupied for 4 hours or more for this self-calibration system to operate properly. Under these conditions, ABC Logic™ should maintain sensor calibration over the lifetime of the sensor. The ABC Logic™ should be turned OFF where a building is continuously occupied 24 hours per day, or where there could be significant sources of non-occupant related CO<sub>2</sub> such as greenhouses, breweries and other industrial and food processing applications.

## Output

### Analog

0 to 5 V, (100  $\Omega$  output impedance)  
0 to 10 V (100  $\Omega$  output impedance) and  
4 to 20mA ( $R_L$  maximum 500  $\Omega$ ) available simultaneously for CO<sub>2</sub> output  
Digital to analog error  $\pm 1\%$

## Warranty/Other

### Warranty

18 months parts and labor

This product is covered by one or more of the following patents:

5,650,624 / 5,721,430 / 5,444,249 / 5,747,808 / 5,834,777 / 5,163,332 /  
5,340,986 / 5,502,308 / 6,344,798 / 6,023,069 / 5,370,114 / 5,601,079 /  
5,691,704 / 5,767,776 / 5,966,077 / 6,107,925 / 5,798,700 / 5,945,924 /  
5,592,147 / 6,255,653 / 6,250,133 / 6,285,290

### Warranty Repairs

Amphenol Advanced Sensors will repair Telaide product that fails to meet the terms provided for in the Return and Warranty Policy Statement (See, <http://www.telaide.com>). Warranty period shall start from date of manufacture and be based on product category and type of equipment as specified in Table 1: Product Warranty Periods. For all warranty repairs, Amphenol Advanced Sensors will bear all product repair parts, labor, and standard ground shipping charges.

### Contact

[www.telaide.com](http://www.telaide.com)

North America and Asia +1 814 834 9140

Europe +44 1823 335 200