

Quick-Start User Manual

TVF SERIES DISPLAY FLOW RATE - TOTALIZING - BATCHING

- ✓ Firmware: v.6.00 or higher
- ✓ Input type: 0/4-20 mA or Pulse
- ✓ Batching and totalizer function



Read the user's manual carefully before starting to use the unit or software.
Producer reserves the right to implement changes without prior notice.



Explanation of symbols used in the manual



This symbol denotes especially important guidelines concerning the installation and operation of the device. Not complying with the guidelines denoted by this symbol may cause an accident, damage or equipment destruction.

IF THE DEVICE IS NOT USED ACCORDING TO THE MANUAL THE USER IS RESPONSIBLE FOR POSSIBLE DAMAGES.



This symbol denotes especially important characteristics of the unit. Read any information regarding this symbol carefully.

1. BASIC REQUIREMENTS AND USER SAFETY



- Do not use the unit in areas threatened with excessive shocks, vibrations, dust, humidity, corrosive gasses and oils.
- Do not use the unit in areas where there is risk of explosions.
- Do not use the unit in areas with significant temperature variations, exposure to condensation or ice.
- Do not use the unit in areas exposed to direct sunlight.
- Make sure that the ambient temperature (e.g. inside the control box) does not exceed the recommended values. In such cases forced cooling of the unit must be considered (e.g. by using a ventilator).

- The manufacturer is not responsible for any damages caused by inappropriate installation, not maintaining the proper environmental conditions and using the unit contrary to its assignment.
- Installation should be conducted by qualified personnel . During installation all available safety requirements should be considered. The fitter is responsible for executing the installation according to this manual, local safety and EMC regulations.



- GND input of device should be connected to PE wire;
- The unit must be properly set-up, according to the application. Incorrect configuration can cause defective operation, which can lead to unit damage or an accident. If in the case of a unit malfunction there is a risk of a serious threat to the safety of people or property additional, independent systems and solutions to prevent such a threat must be used.
- The unit uses dangerous voltage that can cause a lethal accident. The unit must be switched off and disconnected from the power supply prior to starting installation of troubleshooting (in the case of malfunction).
- Neighboring and connected equipment must meet the appropriate standards and regulations concerning safety and be equipped with adequate overvoltage and interference filters.
- Do not attempt to disassemble, repair or modify the unit yourself. The unit has no user serviceable parts. Defective units must be disconnected and submitted for repairs at an authorized service center.



The unit is designed for operation in an industrial environment and must not be used in a household environment or similar.

2. GENERAL CHARACTERISTICS

Main task of TVF Series is measurement of instantaneous flow (flow rate), and counting of total flow, The device can be used as regulator, to control industrial process. Measurement of instantaneous flow can be indicated in range: 0 to 9999 (plus decimal point) and can be expressed in combination of flow measurements (Gallon, litre and m³) and in three time measurements (second, minute, hour). Total flow can be indicated in range from 0.000 to 16 digits with maximum resolution of 0.001 L.

TVF Series can cooperate with flow sensors with current output (0-20mA or 4-20mA). Sensors can be powered from sensor supply output (stabilized, 24VDC +5%, -10% 100mA). The device can be equipped with: two relay outputs, two OC type outputs, one relay and one passive isolated current output or one OC type and one passive isolated current output, which can be driven due to instantaneous flow, total flow or batcher counter value. Build in RS 485 interface enables access to all internal registers, and supports MODBUS RTU communication protocol. The controller can be ordered in two power supply versions.

DEVICE INSTALLATION

The unit has been designed and manufactured in a way assuring a high level of user safety and resistance to interference occurring in a typical industrial environment. In order to take full advantage of these characteristics installation of the unit must be conducted correctly and according to the local regulations.

- Read the basic safety requirements on page 3 prior to starting the installation.
- Ensure that the power supply network voltage corresponds to the nominal voltage stated on the unit's identification label.
- The load must correspond to the requirements listed in the technical data.
- All installation works must be conducted with a disconnected power supply.
- Protecting the power supply connections against unauthorized persons must be taken into consideration.

4.1. UNPACKING

After removing the unit from the protective packaging, check for transportation damage. Any transportation damage must be immediately reported to the carrier. Also, write down the unit serial number on the housing and report the damage to the manufacturer.

Attached with the unit please find:

- User's Manual,

ASSEMBLY



- Disconnect the power supply prior to starting assembly.
- Check the connections are wired correctly prior to switching the unit on.



To install device on the wall, a pinholes should be made. Figure 4.1 presents dimensions of the device and distances between holes. The back side of the device has four mounting holes. This part of the case should be mounted to a wall by screws.

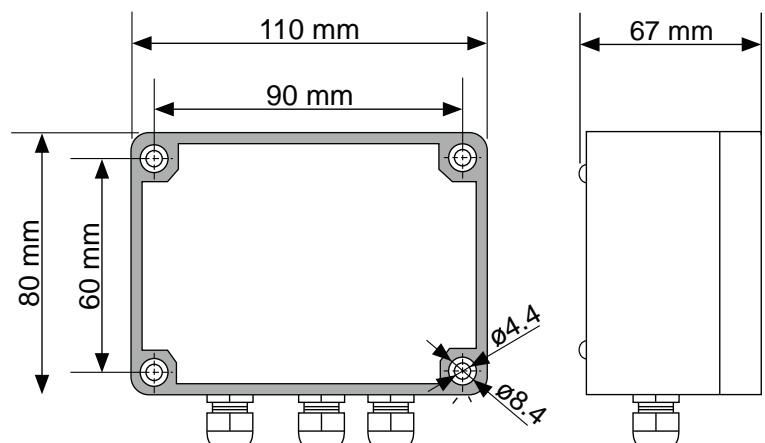

Figure 4.1. Device and assembly dimensions

CONNECTION METHOD

CAUTION



- Installation should be conducted by qualified personnel. During installation all available safety requirements should be considered. The fitter is responsible for executing the installation according to this manual, local safety and EMC regulations.
- The unit is not equipped with an internal fuse or power supply circuit breaker. Because of this an external time-delay cut-out fuse with minimal possible nominal current value must be used (recommended bipolar, max. 2A) and a power supply circuit-breaker located near the unit. In the case of using a monopolar fuse it must be mounted on the phase cable (L).
- The power supply network cable diameter must be selected in such a way that in the case of a short circuit of the cable from the side of the unit the cable shall be protected against destruction with an electrical installation fuse.

Connections of power supply voltage and measurement signals are executed using the clamping connectors inside of the unit's housing.

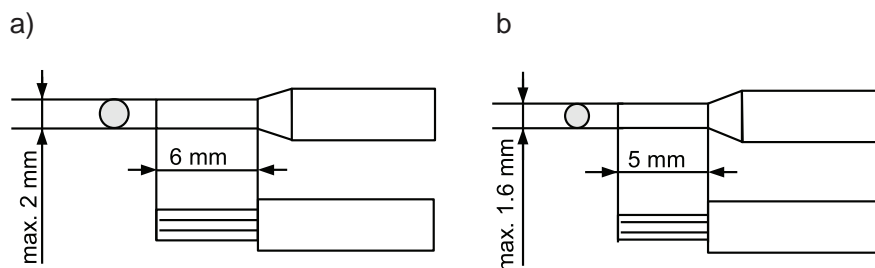

Figure 4.2. Recommended dimensions of cable stripping for big connectors (1 to 6), 07 for small connectors (7 to 13, 15 to 17)

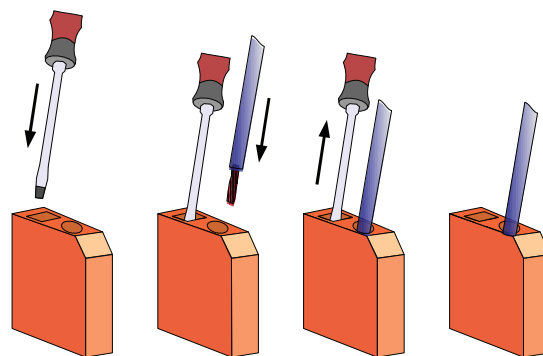

Figure 4.3. Method of connecting cables to the clamping connectors

CAUTION



- All connections must be made while power supply is disconnected.
- Flow sensor connected to current input of flow meter should be installed accordingly to local regulations, and recommendations of the producer.
- Correct installations and application of flow sensor is essential for correct operation flow meter type TVF Series.

The device has 5 buttons being used for main presets programming. To get high protection level, the keyboard is mounted under transparent cover. To allow user to change presets without opening the cover, an IR sensor is mounted. Remote controller contains basic functions to handle menu of the device (note, that remote controller is not a part of the TVF Series set – it is an additional equipment).

Additional features:

- alarm preset; alarm signal is released when measurement exceeds measurement range
- direct access to relays thresholds settings, without password,
- batcher mode.

3. TECHNICAL DATA

Power Supply Voltage (Depending on Version)	85...230...260V AC/DC; 50 ÷ 60 Hz (separated) or 19...24...50V DC and 16...24...35V AC (separated)	
External fuse (required) Power consumption	T - type, max. 2 A max. 4.5 VA @ 85 ÷ 260V AC/DC max. 4.5 VA @ 16V ÷ 35V AC max. 4.5 W @ 19V ÷ 50V DC	
Inputs	0÷20 mA, 4÷20 mA overload protected, maximum input current about 40 mA	NPN PNP Pulse Inputs
Programmable input	Low level : not separated High level : 0V ÷ 1V 10V ÷ 30V (about. 12 mA @ 24V)	
Outputs	Relay : 1 or 2 NO, 5A/250V AC (cos j = 1) OC-type : 1 or 2; 30mA / 30VDC / 100mW passive, isolated current : 0 or 1; range max. 2.8 ÷ 24mA supply voltage: $U_s = 9.5 \div 36V$ load resistance $0 \dots (U_s - 9.5V) / 24mA$ [kW] resolution: 12bits isolation strength 560V DC sensor power supply $U_0 : 24V +5\%, -10\% / \text{max. } 100 \text{ mA, stabilized}$	
Instantaneous Flow Range	0 ÷ 999999 plus decimal point	
Current Measurement Accuracy	± 0,1% @ 25°C; ± one digit (for 0÷20 mA range)	
Accepted Prolonged Input Overload	20%	
Measurement Input Resistance:	50Ω	
Temperature Stability	50 ppm / °C	
Instantaneous Flow Precision	Selected from range: 0 ÷ 0.000	

Instantaneous Flow Unit	Gallons - L or m ³ per min. or sec. or hour
Total Flow Range	16 Digits
Total Flow Precision	Selected from range: 0 ÷ 0.000
Total Flow Unit	Gallons Litres m ³
Batcher Counter Range	65535 m ³
Batcher Counter Precision	Selected from range: 0 ÷ 0.000
Batcher Counter Unit	Gallons Litres m ³
Number of Batches Counter Range	0 ÷ 999999
Communication Interface	RS 485, 8N1 and 8N2, Modbus RTU, not separated
Baud Rate	1200 bit/s ÷ 115200 bit/s
Display	LED, 6 digit, 13mm height, red
Protection Level	IP 65
Housing Type Housing Material Housing Dimensions	Wall Mounted ABS + Fibreglass
without glands :	110 x 80 x 67 mm
with glands :	110 x 105 x 67 mm
Operating Temperature	0°C to +50°C or -20°C to +50°C
Storage Temperature	-10°C to +70°C or -20°C to +70°C
Humidity Altitude	5 to 90% no condensation up to 2000 meters above sea level
Screws Tightening Max. Torque	0.5 Nm
Max. Connection Leads Cross Section	3 mm ² (for connectors 1÷6) or 2 mm ² (for connectors 7÷13, 15÷17)
Protection Level	Saccording to: PN-EN 61010-1 installation category: II pollution degree: 2 voltage in relation to ground: 300V AC insulation resistance: >20MW insulation strength between power supply and input/output terminal: 1min. @ 2300V insulation strength between relays terminal: 1min. @ 1350V
EMC	According to: PN-EN 61326-1



This is a class A unit. In a residential or a similar area it can cause radio frequency interference. In such cases the user can be requested to use appropriate preventive measures.

Symbols and Functions of Push Buttons:



Symbol used in the manual : [ESC/MENU]

Functions:

- Enter to main menu (press and hold for at least 2 sec.)
- Exit the current Screen and Enter to previous menu (or measure mode)
- Cancel the changes made in parameter being edited



Symbol used in the manual : [ENTER] or [PAUSE]

Functions :

- Start to edit the parameter
- Enter into the sub-menu,
- Confirmation of changes made in parameter being edited
- While batcher mode: pause/start batching.



Symbol used in the manual : [^] [v]

Functions :

- Change of the present menu,
- Modification of the parameter value,
- Switching of the display between relay thresholds and number of batches counter.



Symbol used in the manual: [Σ] or [RESET]

Functions :

- Switching of the display between total and instantaneous measurements or batcher counter (while batcher mode only)
- Zeroing the currently displayed counter (press and hold by at least 2 sec.), the zeroing must be confirmed by [ENTER] button.

6. PRINCIPLE OF OPERATION

After turning the power supply on, device ID and software version are showed on the display, next the controller goes to the measurement mode.

6.1. MEASUREMENT MODE

In the measure mode, device displays instantaneous measurement (flow value or time per one unit of flow, depending on „F or P” parameter value) equivalent to quantity of input pulses, total flow or batcher counter value. Instantaneous flow (flow rate) is displayed in units defined by parameter “F unit” (Gal, L or m³) and “Ftunit” (min., sec. or h), with resolution defined by “Point” (max. 3 digits after decimal point). Device converts measured current to selected units accordingly to conversion characteristic selected by user. The measurement range equal to the nominal range is called: nominal measurement range, and the measurement range equal to the extended nominal range is called: permissible measurement range.

FLOW METER CONNECTIONS

TKM Series - 4-20mA Output

- Terminal (7) Blue Wire (-)
- Terminal (8) Brown Wire (+)
- Terminal (11) Yellow Wire (mA +)
- Terminal (12) Grey Wire (mA -)

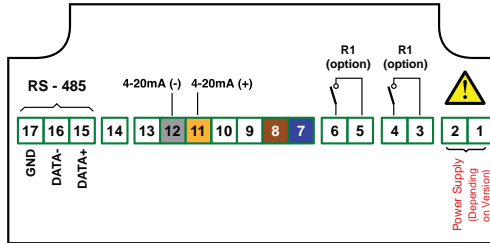

TKS Series - Pulse Output

GPM/Pulse = K Factor

- Terminal (7) Blue Wire (-)
- Terminal (8) Brown Wire (+)
- Terminal (10) Black Wire (NPN Pulse)
- Jump Terminal 13 & 8 Brown Wire

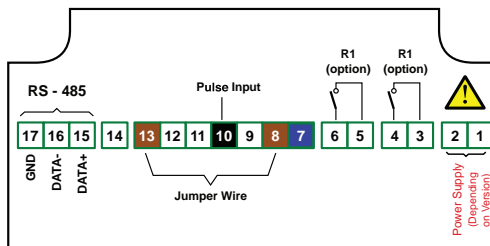

TKW Series - Pulse Output

GPM/Pulse = K Factor

- Terminal (7) Blue Wire (-)
- Terminal (8) Brown Wire (+)
- Terminal (10) Black Wire (Pulse)
- Jump Terminal 13 & 8 Brown Wire

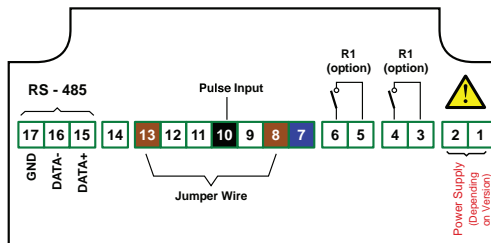

TKW Series - 4-20mA Output

- Terminal (7) Blue Wire (-)
- Terminal (8) Brown Wire (+)
- Terminal (11) Black Wire (mA+)
- Terminal (12) White Wire (mA-)

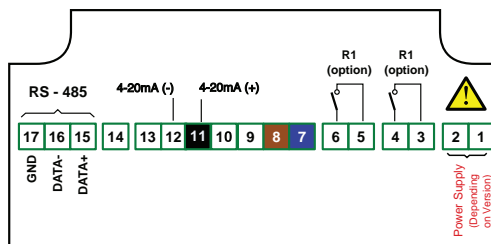

TKP Series - Pulse Output

GPM/Pulse = K Factor

- Terminal (7) Blue Wire (-)
- Terminal (8) Brown Wire (+)
- Terminal (10) Black Wire (Pulse)
- Jump Terminal 13 & 8 Brown Wire

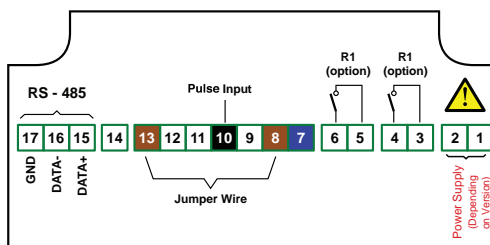

TIW Series - Pulse Output

GPM/Pulse = K Factor

- Terminal (7) Blue Wire (-)
- Terminal (8) Brown Wire (+)
- Terminal (10) Black Wire (Pulse)
- Jump Terminal (13 & 8) Brown Wire

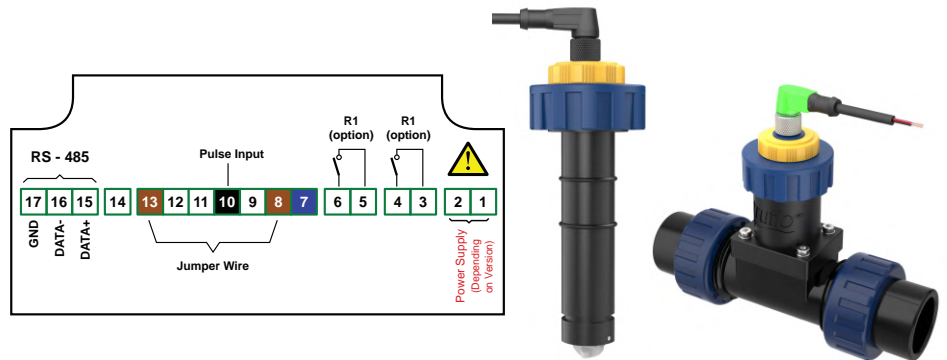

TIP Series | TIM Series - Pulse Output

GPM/Pulse Display = K Factor

- Terminal (7) Blue Wire (-)
- Terminal (8) Brown Wire (+)
- Terminal (10) Black Wire (Pulse)
- Jump Terminal (13 & 8)

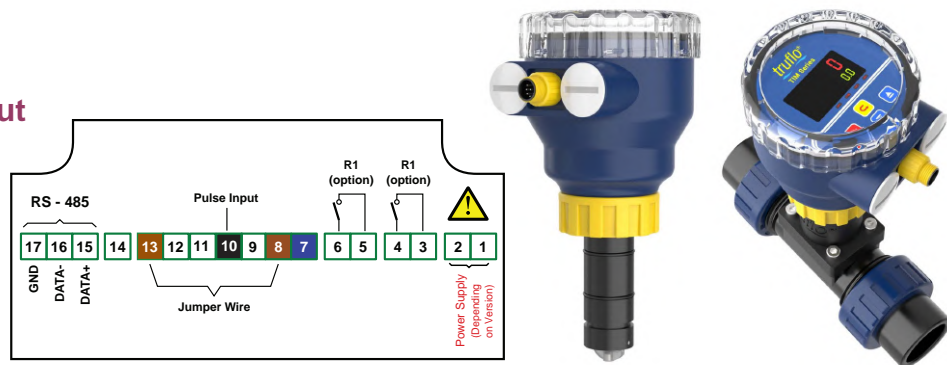

TIM Series - 4-20mA Output

- Terminal (7) Blue Wire (-)
- Terminal (8) Brown Wire (+)
- Terminal (11) Yellow Wire (mA+)
- Terminal (12) Grey Wire (mA-)

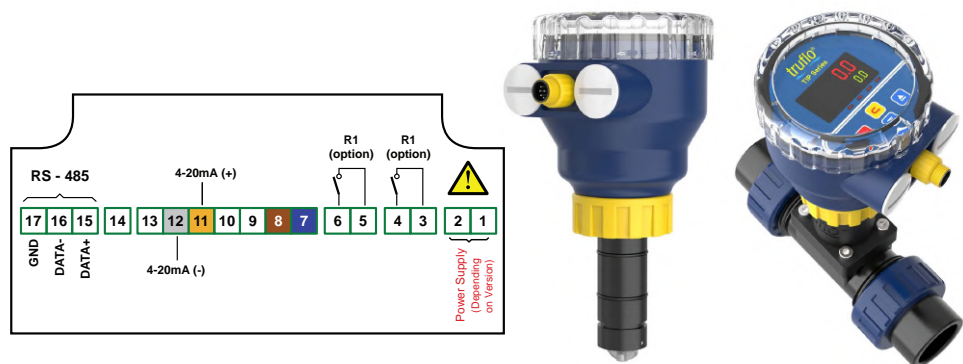

Ultraflo 1000 | 4000 | 5000 - Pulse Output

GPM/Pulse Display = K Factor

Pin 1 : Terminal 8 (+)

Pin 2 : Terminal 10

Pin 3 : Terminal 7 (-)

Jump Terminal (13 & 8)

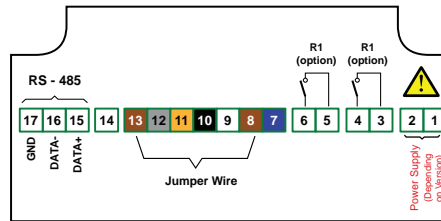

Ultraflo 1000 | 4000 | 5000 - 4-20mA Output

Pin 1 : Terminal 8 (+)

Pin 2 : Terminal 11 (mA +)

Pin 3 : Terminal 7 (-)

Jump Terminal (12 & 7)

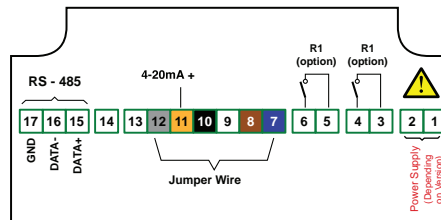

ProPulse - DIN Connection

Pin 1 : Terminal 8 (+)

Pin 2 : Terminal 10 (PNP)

Pin 3 : Terminal 7 Shield (-)

Pin 4 : Terminal 10 (NPN)

Jump Terminal (13 & 8)

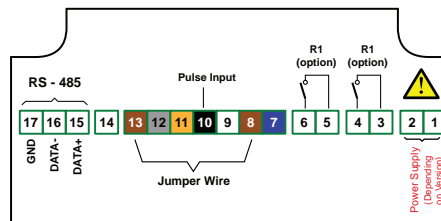

ProPulse - Flying Lead - Pulse Output

GPM/Pulse = K Factor

Terminal 10 Blue Wire (PNP)

Terminal 8 Red Wire (+)

Terminal 7 Shield (-)

Jump Terminal (13 & 8)

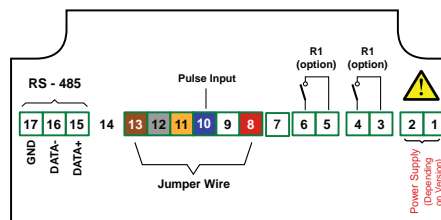

PM Series Mag Meter - Pulse Output

GPM/Pulse = K Factor

Pin 1 : Terminal 8 (+)

Pin 2 : Terminal 10 (NPN)

Pin 3 : Terminal 7 (-)

Jump Terminal (13 & 8)

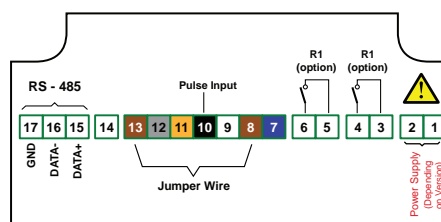

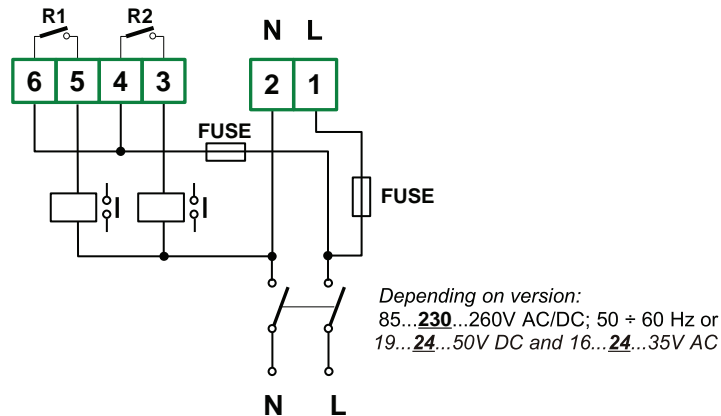

Figure 4.8. Connection of power supply and relays

CAUTION



Contacts of relay outputs are not equipped with spark suppressors. While use the relay outputs for switching of inductive loads (coils, contactors, power relays, electromagnets, motors etc.) it is required to use additional suppression circuit (typically capacitor 47nF/ min. 250VAC in series with 100R/5W resistor), connected in parallel to relay terminals or (better) directly on the load. In consequence of using the suppression circuit, the level of generated electromagnetic disturbances is lower, and the life of relay contacts rises.

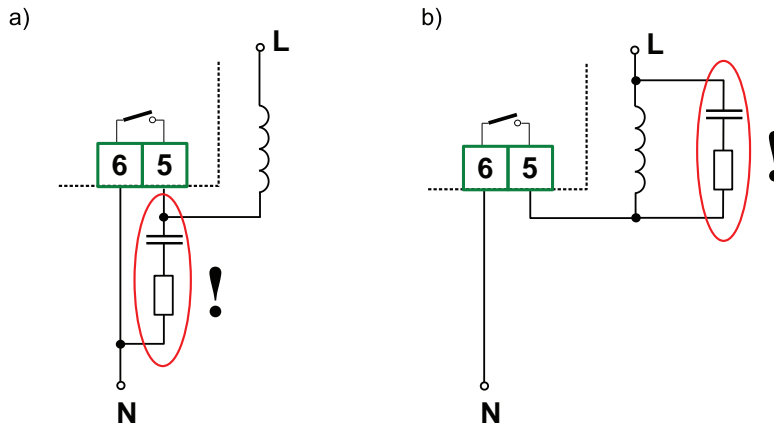

Figure 4.9. Examples of suppression circuit connection:
a) to relay terminals; b) to the inductive load

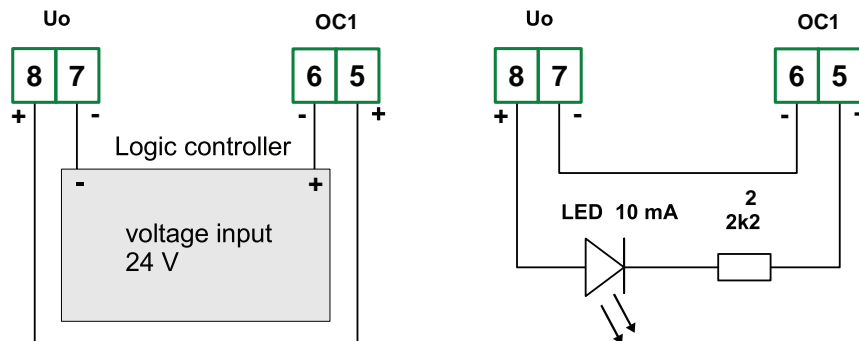

Figure 4.10. Example of OC-type outputs connection

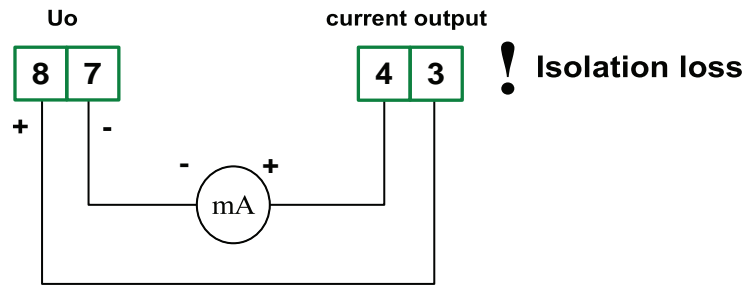

Figure 4.11. Example of current output connection using internal power supply

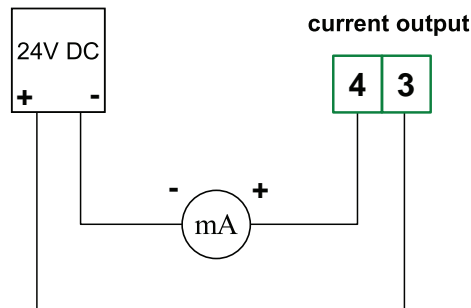

Figure 4.12. Example of current output connection using external power supply

MAINTENANCE

The unit does not have any internal replaceable or adjustable components available to the user. Pay attention to the ambient temperature in the room where the unit is operating. Excessively high temperatures cause faster ageing of the internal components and shorten the fault-free time of unit operation. In cases where the unit gets dirty do not clean with solvents. For cleaning use warm water with small amount of detergent or in the case of more significant contamination ethyl or isopropyl alcohol.



Using any other agents can cause permanent damage to the housing.



Product marked with this symbol should not be placed in municipal waste. Please check local regulations for disposal and electronic products.

5. FRONT PANEL DESCRIPTION

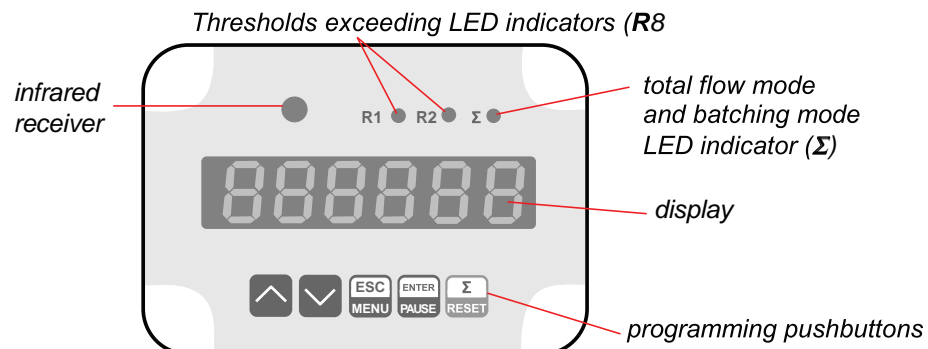

7 MENU STRUCTURE

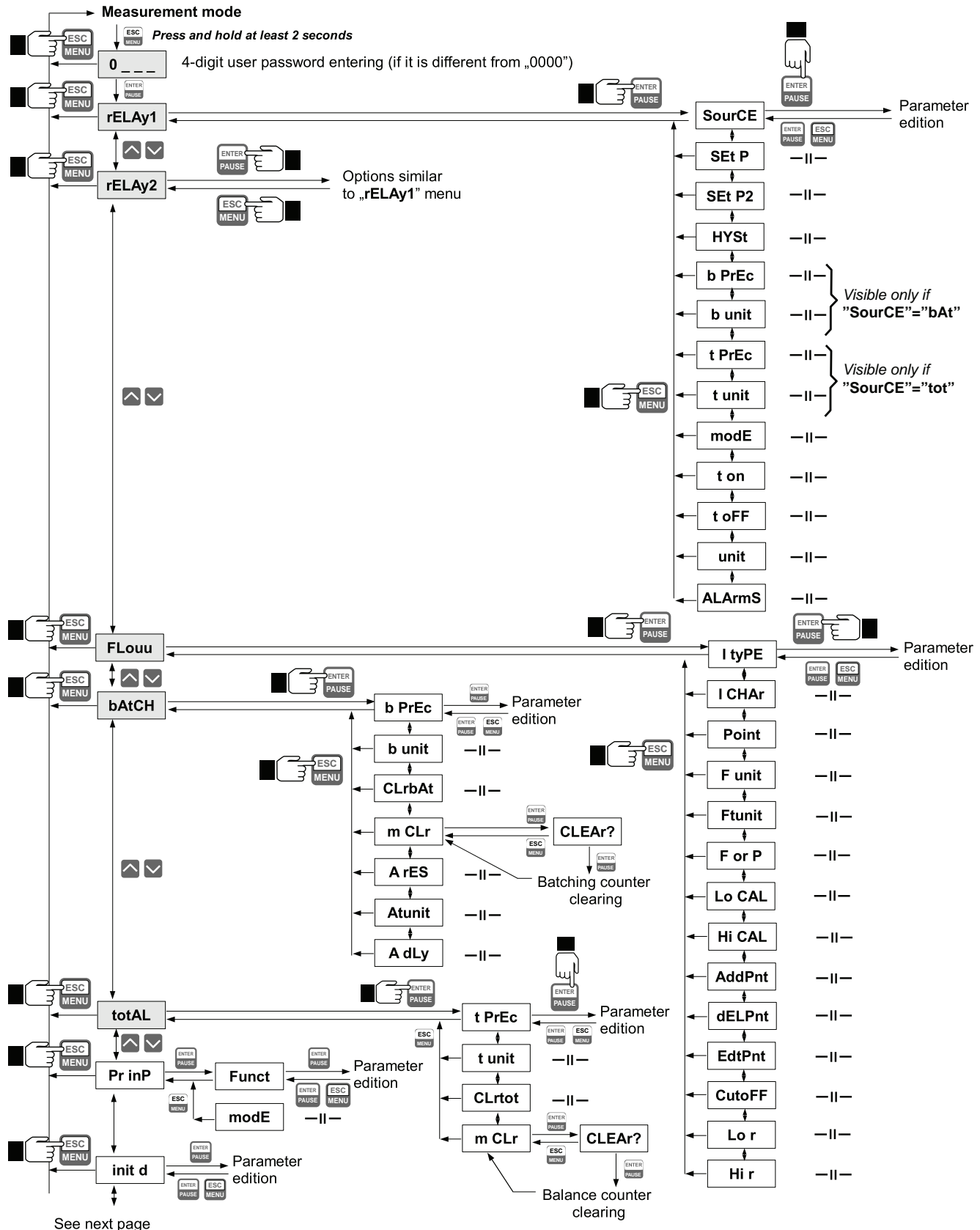

See next page

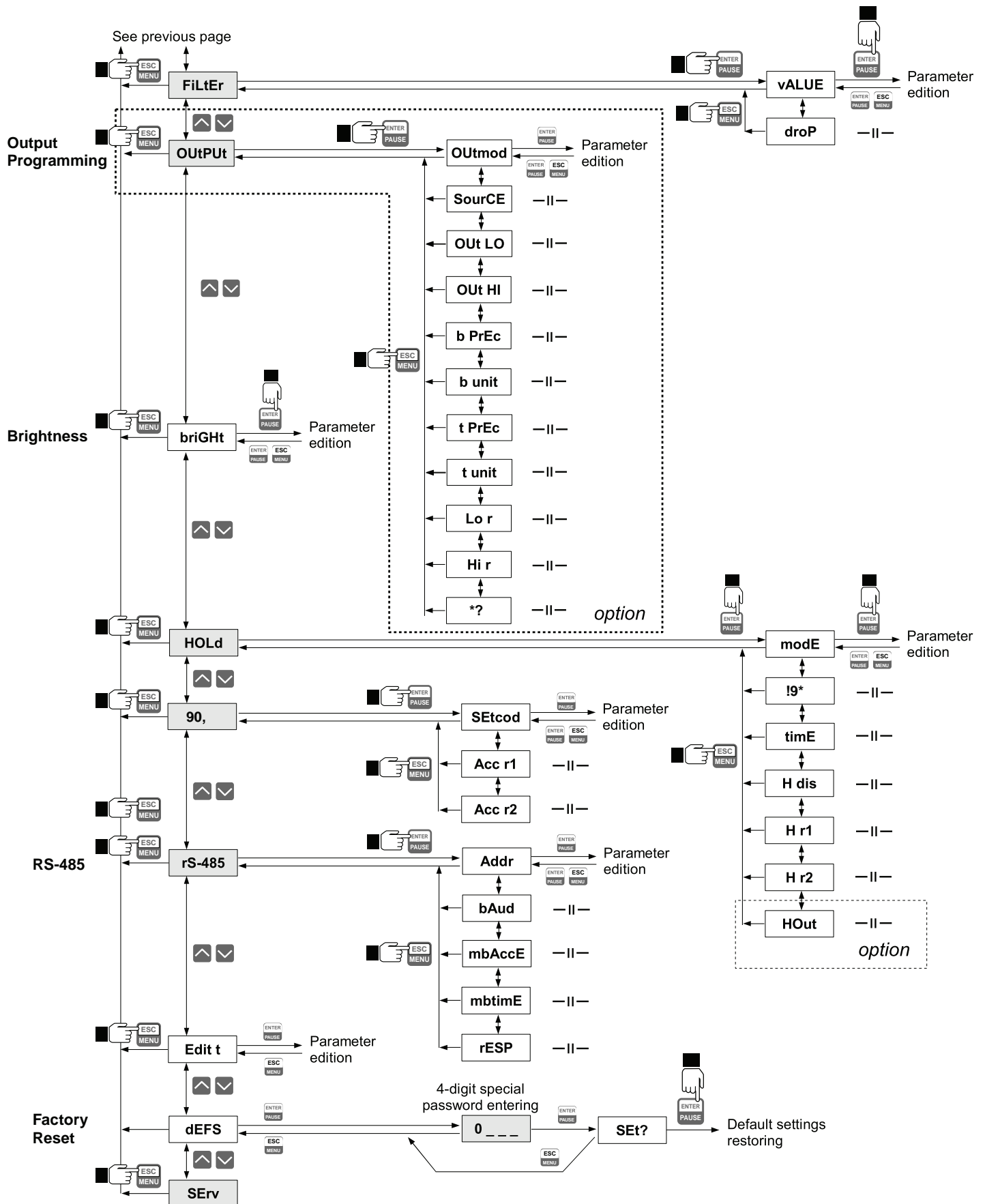

TruVu

User Manual – METER TVL Series



Specification may be modified without notice in advance.

For More Information Visit www.iconprocon.com

or Contact Us @ 905.469.9283

