

CA-CALC™ Combustion Analyzers

Series CA-6100

Operation and Service Manual

P/N 1980451 Revision G
August 2010



TRUST. SCIENCE. INNOVATION.



TSI INCORPORATED

Product Registration

Start Seeing the *Benefits* of Registering Today!

Thank you for your TSI instrument purchase. Occasionally, TSI releases information on software updates, product enhancements and new products. By registering your instrument, TSI will be able to send this important information to you.

<http://register.tsi.com>

As part of the registration process, you will be asked for your comments on TSI products and services. TSI's customer feedback program gives customers like you a way to tell us how we are doing.

TSI Incorporated

USA Website: www.tsi.com

Germany Website: www.tsiinc.de

Singapore E-mail: tsi-singapore@tsi.com

UK Website: www.tsiinc.co.uk

France Website: www.tsiinc.fr

Manufacturer of TSI®, AirFlow™ Instruments, and Alnor® products.

P/N 2980174 Rev F

Copyright © 2010 by TSI Incorporated



Copyright ©

TSI Incorporated / 2002–20010 / All rights reserved.

Part Number

1980451 / Revision G

Address

TSI Incorporated / 500 Cardigan Road / Shoreview, MN 55126 / USA

Fax No.

(651) 490-3824

LIMITATION OF WARRANTY AND LIABILITY (effective July 2000)

Seller warrants the goods sold hereunder, under normal use and service as described in the operator's manual, shall be free from defects in workmanship and material for twenty-four (24) months, or the length of time specified in the operator's manual, from the date of shipment to the customer. This warranty period is inclusive of any statutory warranty. This limited warranty is subject to the following exclusions:

- a. Batteries are warranted for 90 days from the date of shipment to the customer. Electrochemical gas sensors are warranted for a period of twelve (12) months from the date of shipment to the customer.
- b. Parts repaired or replaced as a result of repair services are warranted to be free from defects in workmanship and material, under normal use, for 90 days from the date of shipment.
- c. Seller does not provide any warranty on finished goods manufactured by others or on any fuses, batteries or other consumable materials. Only the original manufacturer's warranty applies.
- d. Unless specifically authorized in a separate writing by Seller, Seller makes no warranty with respect to, and shall have no liability in connection with, goods which are incorporated into other products or equipment, or which are modified by any person other than Seller.

The foregoing is IN LIEU OF all other warranties and is subject to the LIMITATIONS stated herein. **NO OTHER EXPRESS OR IMPLIED WARRANTY OF FITNESS FOR PARTICULAR PURPOSE OR MERCHANTABILITY IS MADE.**

TO THE EXTENT PERMITTED BY LAW, THE EXCLUSIVE REMEDY OF THE USER OR BUYER, AND THE LIMIT OF SELLER'S LIABILITY FOR ANY AND ALL LOSSES, INJURIES, OR DAMAGES CONCERNING THE GOODS (INCLUDING CLAIMS BASED ON CONTRACT, NEGLIGENCE, TORT, STRICT LIABILITY OR OTHERWISE) SHALL BE THE RETURN OF GOODS TO SELLER AND THE REFUND OF THE PURCHASE PRICE, OR, AT THE OPTION OF SELLER, THE REPAIR OR REPLACEMENT OF THE GOODS. IN NO EVENT SHALL SELLER BE LIABLE FOR ANY SPECIAL, CONSEQUENTIAL OR INCIDENTAL DAMAGES. SELLER SHALL NOT BE RESPONSIBLE FOR INSTALLATION, DISMANTLING OR REINSTALLATION COSTS OR CHARGES. No Action, regardless of form, may be brought against Seller more than 12 months after a cause of action has accrued. The goods returned under warranty to Seller's factory shall be at Buyer's risk of loss, and will be returned, if at all, at Seller's risk of loss.

Buyer and all users are deemed to have accepted this LIMITATION OF WARRANTY AND LIABILITY, which contains the complete and exclusive limited warranty of Seller. This LIMITATION OF WARRANTY AND LIABILITY may not be amended, modified or its terms waived, except by writing signed by an Officer of Seller.

Service Policy

Knowing that inoperative or defective instruments are as detrimental to TSI as they are to our customers, our service policy is designed to give prompt attention to any problems. If any malfunction is discovered, please contact your nearest sales office or representative, or call TSI's Customer Service department at (651) 490-2811 or (800) 874-2811.

(This page intentionally left blank)

Contents

| | |
|--|-----------|
| Introduction | 1 |
| Manual Purpose | 1 |
| Using This Manual..... | 1 |
| Warnings and Cautions..... | 1 |
| Chapter 1 Instrument Description..... | 3 |
| Chapter 2 Unpacking..... | 5 |
| List of Standard Components..... | 5 |
| Accessories and Replacement Parts | 5 |
| Chapter 3 Component Identification..... | 7 |
| The Gas Sensors | 9 |
| The Sampling Probe..... | 9 |
| Flue Probe Thermocouple (CA-6120, CA-6130, CA-6140) | 9 |
| On-Board Temperature Measurement (CA-6120, CA-6130, CA-6140)..... | 9 |
| Diaphragm Pump | 9 |
| Draft Sensor (CA-6110, CA-6140) | 10 |
| Water Trap..... | 10 |
| Optional Combustion Supply Air Thermocouple Probe (CA-6120, CA-6130, CA-6140)..... | 10 |
| Optional Protective Boot..... | 10 |
| Schematic Representation of Series CA-6100 CA-CALC Analyzer | 11 |
| Chapter 4 Getting Started | 13 |
| Supplying Power | 13 |
| Connecting the Sampling Probe | 13 |
| Connecting the Optional Combustion Supply Air Temperature Probe (CA-6120, CA-6130, CA-6140) | 14 |
| Connecting the Optional Portable Printer..... | 14 |
| Connecting to a Computer | 15 |
| Default Instrument Settings | 15 |
| Factory Defaults and Language Selection | 15 |
| Chapter 5 Basic Operation..... | 17 |
| Buttons and Button Operations | 17 |
| Startup | 18 |
| Characters and Display Icons | 19 |
| Measurements and Calculations..... | 20 |

| | |
|---|-----------|
| Chart of Measurements for Series CA-6100 CA-CALC | |
| Instrument Models..... | 20 |
| Data Display, Viewing Measurements and Calculations..... | 22 |
| Using the Sampling Probe..... | 23 |
| Draft Measurement (CA-6110, CA-6140)..... | 24 |
| Printing to the Portable Printer and to a Computer (All Models)..... | 25 |
| Handling Data..... | 27 |
| Chapter 6 MENU Options | 31 |
| LITE Menu Option..... | 32 |
| FUEL Menu Option..... | 32 |
| UNIT Menu Option (Changing Units) | 33 |
| INT.S MENU Option | 34 |
| TIME MENU Option (Set Time and Date) | 34 |
| CAL MENU Option | 34 |
| CAL.F MENU Option—Setting the Calibration Factor..... | 39 |
| BAUD Rate MENU option..... | 40 |
| COMM MENU Option—Set the Output Communications Device..... | 41 |
| FP MENU Option—Fuel Parameters (CA-6120, CA-6130, CA-6140)..... | 42 |
| Fuel Parameter Descriptions for U.S. Fuels..... | 43 |
| FP Fuel Parameters for Siebert Calculation—Siebert Fuel Parameters | 43 |
| LANG MENU Option..... | 44 |
| Chapter 7 Setup for Gas Calibration | 45 |
| The Calibration Setups | 45 |
| Chapter 8 Maintenance and Troubleshooting..... | 49 |
| Emptying Water Trap..... | 49 |
| Changing the (optional) Water Trap Filter | 49 |
| Cleaning the Sample Probe..... | 50 |
| Installing a Gas Sensor | 50 |
| Adding a CO Sensor to the Model CA-6120 | 52 |
| Disabling CO Sensor Recognition by a Model CA-6130..... | 52 |
| Appendix A Error Codes | 53 |
| Appendix B Calculations..... | 55 |
| CO _u Undiluted CO Concentration Calculation | 55 |
| Excess Air Calculation..... | 55 |
| Calculating Combustion Efficiency for U.S. Fuels..... | 55 |
| Siebert Formula | 56 |
| Determining CO ₂ Using the O ₂ Concentration | 57 |

A General Equation for the Combustion of a Simple Hydrocarbon in Air 57
Calculating CO₂ Max From the Carbon Content 57
Calculation of Combustion Air Requirement 57

Appendix C Series CA-6100 CA-CALC™ Combustion Analyzer Specifications 59



(This page intentionally left blank)

Introduction

Manual Purpose

This manual describes the operation and maintenance of TSI Series CA-6100 CA-CALC™ portable combustion analyzers (Models 6110, 6120, 6130, and 6140).

Using This Manual

Before using your CA-CALC™ Combustion Analyzer, review this manual in its entirety.

Much of the information in this manual is applicable for all Series CA-6100 instruments. Where information is applicable to a particular model, notation is made.

Warnings and Cautions

The manual assumes that you have a basic understanding of combustion safety concerns and are thoroughly familiar with the fuel burning equipment being tested. If you are using measurements as the basis for equipment adjustments, rely on your good judgment and experience together with the measured data. This is especially important where safety issues are of concern. Equipment adjustments must always coincide with the fuel burning equipment manufacturer's recommendations.



W A R N I N G

High temperatures and toxic gases are produced when fossil fuels are burned. Only qualified individuals, thoroughly familiar with operating and adjusting fuel-burning equipment, should use gas measurements for the purpose of making equipment adjustments.



N o t e

The CA-CALC™ analyzer is **not** intended for use as a continuous monitor.

Notes: *Best results are obtained if the CA-CALC™ combustion analyzer is allowed to stabilize at the temperature of the test environment before using.*

To reduce sensor exposure to gas and to reduce build up of water vapor in the sampling lines and water trap, turn the pump off when not making measurements.

Chapter 1

Instrument Description

The Series CA-6100 CA-CALC™ Combustion Analyzers are portable instruments designed for measuring combustion gases, combustion gas temperatures and draft pressure. These measurements are used to evaluate the performance of burners in boilers, furnaces, and hot water tanks. From the measured data, the CA-CALC™ combustion analyzers calculate a variety of combustion parameters including CO concentration, excess air, CO₂ level, combustion efficiency and draft. Measurements for your CA-CALC™ analyzer will depend upon its Model number designation.

Series CA-6100 CA-CALC™ Combustion Analyzer Models

| Model | Description | Measurements |
|---------|---|---|
| CA-6110 | Safety Monitor, CO and Draft, | CO, Draft |
| CA-6120 | Boiler and Furnace Efficiency Monitor | O ₂ , Temperature |
| CA-6130 | Boiler and Furnace Tune-up Monitor | CO, O ₂ , Temperature. |
| CA-6140 | Boiler and Furnace Tune-up Monitor with Draft | CO, O ₂ , Temperature, Draft |

Series CA-6100 CA-CALC™ Measurements and Calculations

| Model Number | Measured with Sensor | Calculations |
|--------------|---|--|
| CA-6110 | CO and Draft | n/a |
| CA-6120 | O ₂ , Flue/stack and Supply Air Temperature | Excess air, Fuel Efficiency, Loss, qA, %CO ₂ |
| CA-6130 | O ₂ , CO, Flue/stack and Supply Air Temperature | Excess air, Fuel Efficiency, Loss, qA, %CO ₂ , undiluted CO, CO ratio |
| CA-6140 | O ₂ , CO, Flue and Supply Air Temperature, Draft | Excess air, Fuel Efficiency, Loss, qA, %CO ₂ , undiluted CO, CO ratio, draft and differential pressure. |

The Series CA-6100 CA-CALC™ Analyzers are supplied with a sampling probe having an in-line water trap and particulate filter. For instruments measuring temperature, the sample probe has an integral thermocouple.

The Series CA-6100 CA-CALC™ Analyzers operate using either an AC power supply or AA-size batteries.

The Series CA-6100 CA-CALC™ Analyzers can store individual data samples (up to 24), and print the data to a portable printer or computer. Stored data can be saved over a user-defined interval and averaged if required.

The Series CA-6100 CA-CALC™ Analyzers (not CA-6110) have a variety of standard fuels, and enable you to modify the fuel parameters, or to install your own *user* defined fuel. Loss and efficiency are calculated from standard heat-loss calculations or using the Siegert formula (refer to [Appendix B](#)).

Chapter 2

Unpacking

Carefully unpack your CA-CALC™ combustion analyzer and accessories from the carrying case. Check the individual parts against the list of components in the table below. If items are missing or damaged, notify TSI immediately.

List of Standard Components

| Qty. | Item Component | Part/ Model |
|------|--|-------------|
| 1 | Series CA-6100 CA-CALC combustion analyzer, carrying case, and boot (<i>case and boot not included with Model CA-6110</i>) | |
| 1 | Sample probe with water trap, draft line and temperature | 801991 |
| | Sample probe with water trap and temperature | 801990 |
| | Sample probe with water trap and draft line | 801992 |
| 4 | AA cell alkaline batteries | |
| 1 | Operation and Service manual | 1980451 |

Accessories and Replacement Parts

| | Item | Part/Model |
|---|--|------------|
| 1 | Combustion Supply Air thermocouple <i>Type K</i> | 3013003 |
| 1 | Portable printer kit | 801994 |
| 1 | Universal Power supply 7.2 V with assorted plug types | 2182003 |
| 1 | Boot with magnet and carrying strap | 801995 |
| 1 | Computer cable | 8940 |
| 1 | Hard side Carrying case | 1500134 |
| 1 | Replacement pump | 801996 |
| 1 | CO replacement sensor | 802006 |
| 1 | O ₂ replacement sensor | 802012 |
| 1 | Water trap filters | 1602309 |
| 1 | Lithium battery | 1208028 |
| 1 | Calibration kit O ₂ (N ₂ gas) and CO | 802003 |

(This page intentionally left blank)

Chapter 3

Component Identification

Key components of the CA-CALC™ combustion analyzer and sampling probe are identified in Figures 1 and 2, and under section headings in the text that follows.

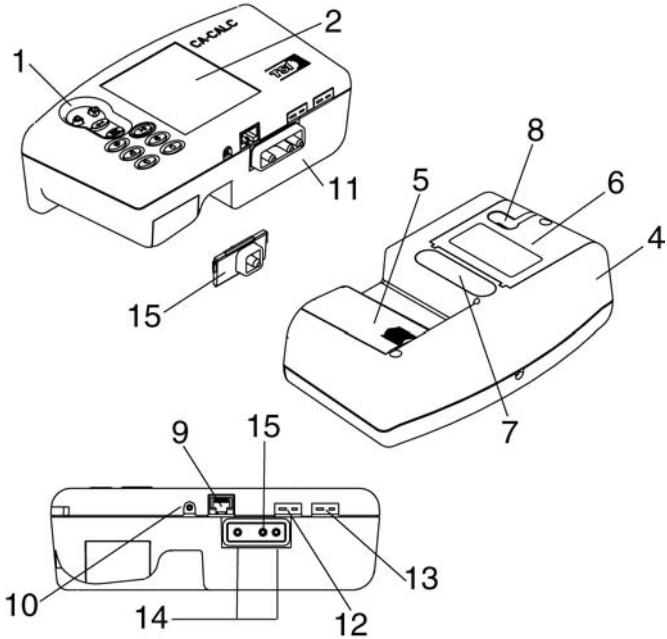

- | | |
|--------------------|---|
| 1. Buttons | 9. RS-232 interface connector |
| 2. Display | 10. AC power input connector |
| 3. Top cover | 11. Sample port* |
| 4. Case bottom | 12. Flue/stack thermocouple port* |
| 5. Battery cover | 13. Port for supply Air temperature probe* |
| 6. Sensor cover | 14. Optional draft measurement ports [left side (reference), right side (stack)]* |
| 7. Damping chamber | 15. Sample port Models CA-6120, CA-6130* |
| 8. Gas vent | |

*For 11–15 see Figure 4 for Model details.

Figure 1. Series CA-6100 CA-CALC™ Combustion Analyzer

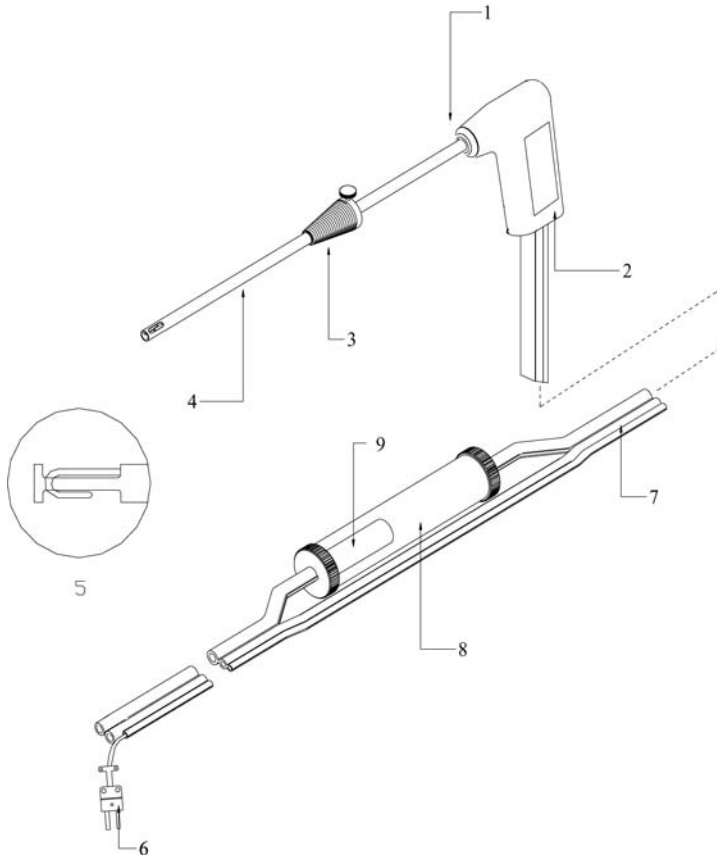

- | | |
|--|---|
| <ul style="list-style-type: none"> 1. Tube retaining fitting (some models) 2. Probe handle 3. Position collar 4. Sample tube 5. Probe tip with thermocouple | <ul style="list-style-type: none"> 6. Thermocouple connector (some models) 7. Flexible sample line 8. Water Trap 9. Water trap filter |
|--|---|

Figure 2. CA-CALC™ Sampling Probe Components

The Gas Sensors

Your CA-CALC™ analyzer has the following electrochemical gas sensors.

| Model | Description | Gas Sensor |
|---------|---|--------------------|
| CA-6110 | CO and Draft, Safety Monitor | CO |
| CA-6120 | Boiler and Furnace Efficiency Monitor | O ₂ |
| CA-6130 | Boiler and Furnace Tune-up Monitor | CO, O ₂ |
| CA-6140 | Boiler and Furnace Tune-up Monitor with Draft | CO, O ₂ |

The Sampling Probe

Your combustion analyzer comes equipped with a sampling probe similar to that depicted in Figure 2. If the model has temperature measurement capability (Models 6120, 6130, 6140), a thermocouple is present and extends to the end of the stainless sampling tube. For Model CA-6140 instruments, the probe tube is removable for cleaning. For instruments measuring draft (Models 6110 and 6140), a draft sampling line is present.

Flue Probe Thermocouple (CA-6120, CA-6130, CA-6140)

For instruments measuring temperature (Models 6120, 6130, 6140), a Type K thermocouple probe extends through the SS sampling tube on the probe to its tip, where flue temperatures are measured. The thermocouple probe measures temperatures up to 700 degrees C (1300 degrees F).

The Type K thermocouple connector plugs into the flue (*stack*) thermocouple port (see Figure 1).

On-Board Temperature Measurement (CA-6120, CA-6130, CA-6140)

Your CA-CALC™ analyzer uses an on-board temperature detector to provide the combustion supply air temperature when no supply-air accessory probe is present.

Diaphragm Pump

The CA-CALC™ analyzer, samples exhaust gases from the flue, and delivers them to the electrochemical sensors using a diaphragm sampling pump. The pump is accessed through the sensor cover (see Figure 1), and can be removed for cleaning or for replacement. Typical pump life is 1000 hours.

Draft Sensor (CA-6110, CA-6140)

A differential pressure transducer in CA-CALC™ analyzer models CA-6110 and CA-6140 is used to measure draft pressure. The transducer has a measurement range of $\pm 30''$ of H₂O (7.47 kPa).

Water Trap

The water trap shown in Figure 2 is used to remove moisture that collects in the sample tubing when combustion gases are sampled. The water trap uses two chambers and a *hydrophobic* coalescing filter to maximize water removal.

Optional Combustion Supply Air Thermocouple Probe (CA-6120, CA-6130, CA-6140)

A measurement of the *Combustion Supply Air* temperature is made using a Type K thermocouple probe having a “miniature” type connector. The probe is plugged into the receptacle identified in Figure 1, reference 13.

When a Supply Air temperature probe is not used, the supply air temperature is assumed to be the instrument temperature, and is measured automatically by an on-board temperature sensor.

Optional Protective Boot

An optional protective boot is available for your instrument. The boot provides drop protection for the instrument and is supplied with a magnet, enabling the instrument to be mounted on a flat, vertical metal surface. The boot is equipped with a carrying strap.

Schematic Representation of Series CA-6100 CA-CALC™ Analyzer

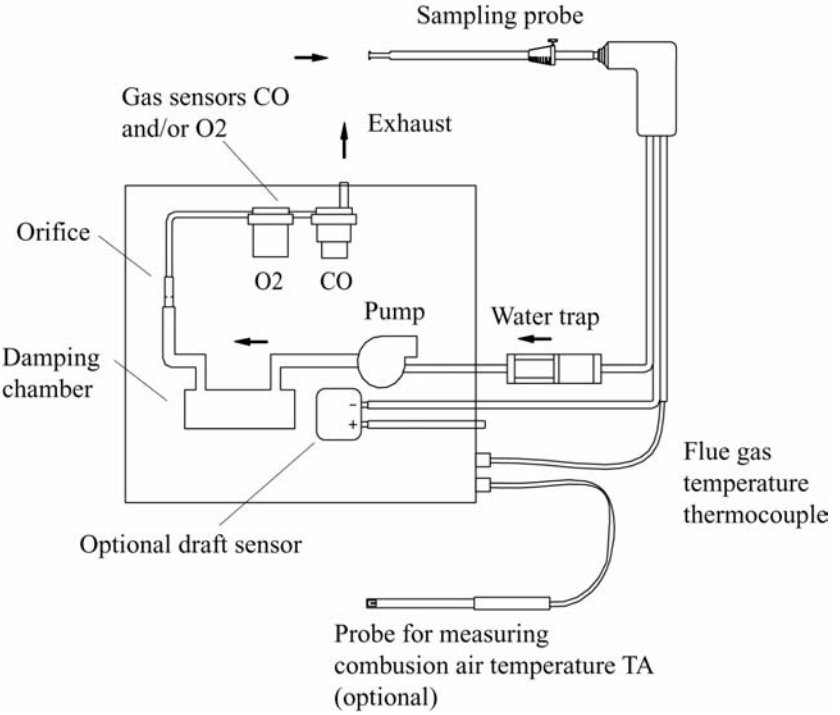

Figure 3. Schematic Representation of Series CA-6100 CA-CALC™ Analyzer

(This page intentionally left blank)

Chapter 4

Getting Started

Supplying Power

The CA-CALC™ portable combustion analyzer operates using 4 AA batteries or an AC adapter. Quality alkaline batteries enable the instrument to operate for at least 10 hours. Use of the plug-in AC adapter conserves battery life, and can be substituted for batteries.

Installing Batteries

Turn the combustion analyzer over and remove the battery cover by pushing down on the cover latch tab with your thumb and sliding the cover back, away from the instrument case. Remove the battery holder from the battery compartment. Note the orientation of the contacts on the holder and in the instrument. Replace the used batteries with new batteries, matching the + and – terminals, as indicated on the battery holder. Replace the battery cover.

Connecting the Optional AC Adapter

Connect the corresponding connector plugs to the AC wall source and instrument power connection located on case bottom (see Figure 2). When using the power supply, the batteries are bypassed.

Note: The CA-CALC™ analyzer does not charge rechargeable batteries.

Connecting the Sampling Probe

The sampling probe depicted in Figure 2, is connected to the instrument by pushing the sample and draft tube over the ports on the instrument. Refer to the figures below showing the proper connection of the probe tubes to the instrument sample ports. Note that the Type K thermocouple connector can be inserted only one way. The thermocouple connector is oriented with the large spade to the left. **Do not force the connector.**

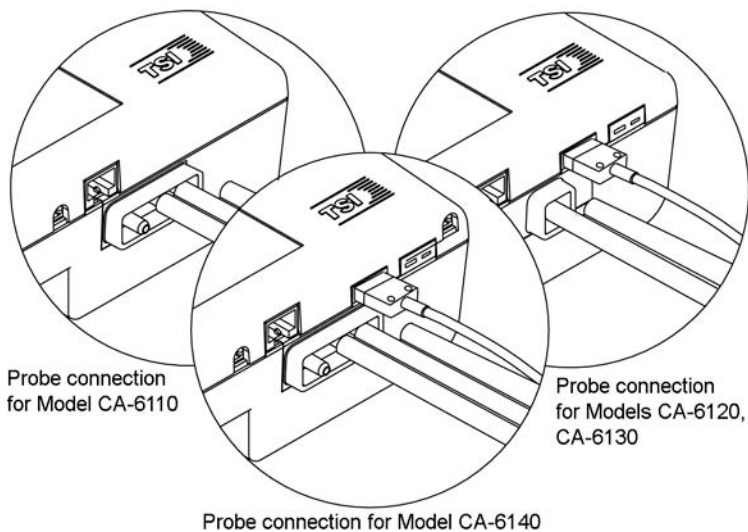

Figure 4. Sampling Probe Connections

Connecting the Optional Combustion Supply Air Temperature Probe (CA-6120, CA-6130, CA-6140)

For Models CA-6120, 6130 and 6140 an optional Type K thermocouple probe (TSI PN 3013003) may be used to measure the temperature of the air supplied to the burner; the *Combustion Supply air*. Connect the optional supply air thermocouple (see “Optional Accessories”) to the supply air thermocouple port depicted in Figure 1. The thermocouple connector can be inserted only one way—large spade to the left. **Do not force the connector.**

Connecting the Optional Portable Printer

Find the printer interface cable included with the optional portable printer. For the serial printer, connect the large 9-pin connector on the cable to mating connector on the printer. Connect the opposite end to the instrument’s RS-232 communications and printer port. See Figure 1 for port location.

The printer and CA-CALC™ combustion analyzer have both been factory set for a baud rate of 1200. If baud rates are not matched, the printer will print random characters, question marks or asterisks. Printer settings are described in the printer manual, along with illustrations identifying the correct DIP-switch configuration. You will also need to set your communication device (COM) to PRN for printer. To set the CA-CALC™ baud rate and device settings, refer to Chapter 6, “[MENU Options.](#)”

Connecting to a Computer

Use the *optional* computer interface cable, Model 8940, to transfer (download) data serially from the CA-CALC™ analyzer to a computer. Connect the large 9-pin connector on the computer interface cable to the 9-pin serial connector on your computer. Connect the opposite end to the instrument's RS-232 communications and printer port. See Figure 1 for port location. Set the baud rate of the CA-CALC™ to that of your computer, as described in Chapter 6, "[MENU Options](#)." The factory preset baud rate is 1200. Set the COMM option to COMP so serial data is formatted for output to the computer. The alternative is PRN, indicating output formatted for printer output. Press the Print button to send data to the computer.

Default Instrument Settings

The CA-CALC™ combustion analyzer uses a number of parameter settings for presenting measured data, performing calculations, and controlling instrument operation. These include the measurement units, the fuel used, the baud rate, and so on. When shipped, your instrument has factory preset parameter settings and the selection of E (English) as the *Default* language. When another language is chosen from the language MENU option, different settings are automatically installed. These are indicated in the table below. Specific settings are easily changed as described in Chapter 6, "[MENU Options](#)"; however, settings are reset to those listed below if the language is changed.

Factory Defaults and Language Selection







| Language Selection | E (Default) | D, FI, S, N, I |
|--------------------|--|--------------------------|
| O ₂ | % | % |
| CO | PPM (parts per million) | PPM |
| Draft units | Inches H ₂ O | mbar |
| Temp units | Degrees Fahrenheit | Degrees Centigrade |
| Excess Air | %EA | $\lambda = \%EA/100 + 1$ |
| Effc./Loss basis | ASME | Siebert formula |
| Effc./loss units | % (net) | % qA |
| Fuel parameters | C, H, H ₂ O, HHV, CO ₂ max | A2 B |
| Fuel list | U.S. Fuels | Siebert Fuels |
| Fuel | Natural Gas | Natural Gas |
| Baud Rate | 1200 | 1200 |
| Sampling interval | 1 second | 1 second |
| Communications | Printer format | Printer format |
| Time | MM / DD / YY | DD / MM / YY |

(This page intentionally left blank)

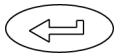
Chapter 5

Basic Operation

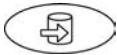
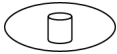
Buttons and Button Operations

| | |
|---|---|
|  | ON-OFF Control Button Turns the instrument on and off . |
|  | The ENTER Control Button Press the ENTER button to execute a command, such as selecting a menu item. |
|  | The ESC Control Button Used to return to the previous screen or cancel a process. |
|  | ARROW Control Buttons Use the arrow buttons to step between items and change values. |
|  | The PUMP On-Off Button Turns the pump on or off. |
|  | The PRINT Button Send data to a printer or computer through the serial port. |
|  | The SAVE Data Button Save current data. Up to 20 samples. |
|  | The REVIEW Data Button Review currently saved data samples. |
|  | The CLEAR Data Button Clear currently saved data samples. |

Startup

Remove the sampling probe from the flue or disconnect the sample tubing from the sampling port. Press the ON-OFF button. The following is a diagram of the start-up sequence, and shows screens displayed during start up. If no errors are detected, the Data Display screen is displayed when the sequence is complete.

While the WARM screen is displayed, the O₂ sensor is automatically calibrated using ambient air, and the CO sensor is zeroed. At the end of the WARM sequence (30 seconds), the pump stops and the draft sensor is zeroed.

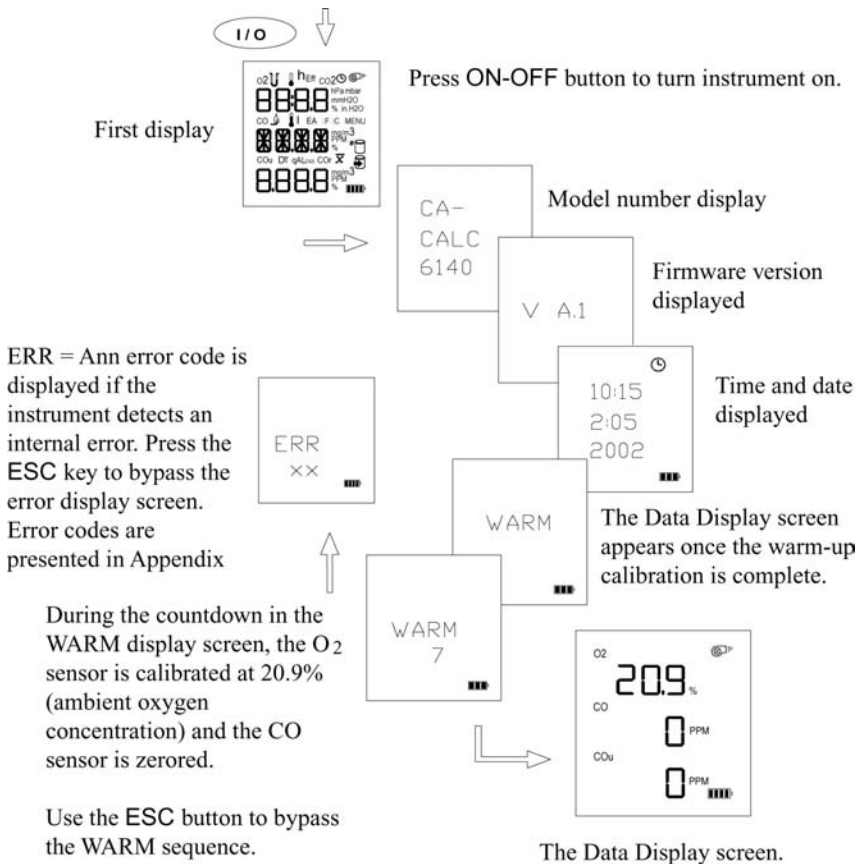
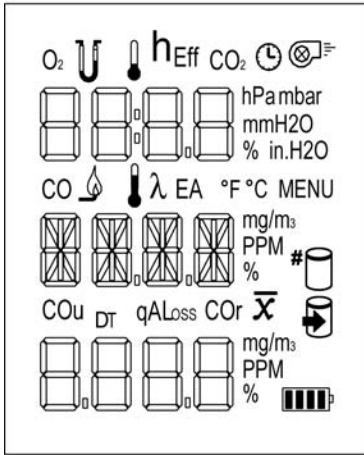

Figure 5. Startup Sequence

Characters and Display Icons

Refer to F below to identify the icons and characters that comprise the main Data Display screen. The display icons indicate measurements made, units, or functions performed. The icons that appear depend on the instrument model, measurement and calculation capabilities. Refer to [Chapter 1](#) for a general description of your instrument model. Also refer to the next section, “[Measurements and Calculations.](#)”



Icons

| | |
|--------------------|-------------------------------------|
| O ₂ | oxygen reading |
| U | draft measurement |
| ↓ | combustion air temperature |
| ↑ | flue or stack air temperature |
| h | 100% - qA% |
| Eff | 100% - Loss |
| CO ₂ | carbon dioxide calculation |
| 🕒 | time/date displayed |
| 🌀 | pump on |
| CO | carbon monoxide reading |
| 🔥 | fuel type displayed |
| λ | Lambda, 1 + %EA/100 |
| EA | % Excess Air |
| mg/m ³ | flue or stack air temperature |
| PPM | parts per million |
| % | percent |
| 🔋 | battery life indicator |
| °F | degrees fahrenheit |
| °C | degrees celsius |
| MENU | menu items |
| CO _u | calculation of undiluted CO |
| DT | stack temperature - air temperature |
| qA | Seigert loss value |
| Loss | ASME loss value |
| CO _r | CO ratio |
| hPa | hecto-pascal draft unit |
| mbar | millibar draft units |
| mmH ₂ O | mm of water, draft unit |
| % | percent displayed |
| ⌘ | averaged values displayed |
| # | number of samples displayed |
| 📄 | in data review mode |
| 📁 | save data mode |

Figure 6. LCD Display and Description of Icons

Measurements and Calculations

Chart of Measurements for Series CA-6100 CA-CALC™ Instrument Models

| Measurement | CA-6110 | CA-6120 | CA-6130 | CA-6140 |
|-----------------------|---------|---------|---------|---------|
| O ₂ oxygen | | X | X | X |
| CO carbon monoxide | X | | X | X |
| CO ₂ | | X | X | X |
| Flue (stack) temp TS | | X | X | X |
| Air temp TA | | X | X | X |
| ΔT | | X | X | X |
| Excess air or lambda | | X | X | X |
| Loss (ASME) | | X | X | X |
| qA (Siegert) | | X | X | X |
| Efficiency | | X | X | X |
| Efficiency (Siegert) | | X | X | X |
| COu | | | X | X |
| CO _r | | | X | X |
| Draft | X | | | X |

Oxygen Measurement (CA-6120, CA-6130, CA-6140)

Models equipped with an O₂ electrochemical sensor oxygen (see table above) measure oxygen concentration in the range of 0 to 25%, and perform calculations to determine the concentration of %CO₂ in the exhaust.

All Models with O₂ sensor are also equipped for measuring flue temperature. O₂ and temperature measurements together, enable the calculation of flue heat loss and efficiency.

Carbon Monoxide Measurement (CA-6130, CA-6140)

Models equipped with the CO electrochemical sensor measure carbon monoxide in the range of 0 to 9999 PPM. Models with an O₂ sensor too, calculate *undiluted CO* and *CO ratio*.

CO₂ Measurement

Models with an O₂ sensor calculate %CO₂.

Flue/stack Temperature, TS (CA-6120, CA-6130, CA-6140)

Flue temperature measured with sampling probe.

Combustion Air Temperature, TA (CA-6120, CA-6130, CA-6140)

Measurement of combustion air is determined using the temperature probe accessory, TSI PN 3013003. In the absence of this probe, the combustion air temperature is determined from a temperature sensor in the instrument case.

ΔT , Temperature Difference (CA-6120, CA-6130, CA-6140)

The flue/stack temperature minus the combustion air temperature.

Excess Air or Lambda (λ) (CA-6120, CA-6130, CA-6140)

Calculations of these values are found in [Appendix B](#).

Loss (CA-6120, CA-6130, CA-6140)

Heat loss from the hot gases exiting the flue/stack. Includes latent heat loss from the formation of water vapor. See [Appendix B](#).

qA (CA-6120, CA-6130, CA-6140)

Heat loss using the Siegert formula. See [Appendix B](#).

Efficiency (CA-6120, CA-6130, CA-6140)

Combustion efficiency: 100 percent minus Loss above. See [Appendix B](#).

η Siegert Efficiency (CA-6120, CA-6130, CA-6140)

Combustion efficiency: 100 percent minus qA above. See [Appendix B](#).

CO_u, Undiluted carbon monoxide concentration (CA-6130, CA-6140)

Calculation of the CO concentration, undiluted by excess air. This calculation requires a measurement of the O₂ concentration and CO measurement. Not available with models CA-6110 and CA-6120. Refer to [Appendix B](#).

CO_r, CO ratio (CA-6130, CA-6140)

Ratio of CO to CO₂. See [Appendix B](#).

Data Display, Viewing Measurements and Calculations

Measurements and calculations are presented in the Data Display screens. The Data Displays appear once the Startup sequence is complete as illustrated earlier in Figure 5.

Refer to Figure 7 below. The appropriate character or icon appears above the data shown. Select the appropriate data display using the arrow buttons. For the Model CA-6110, only one data display screen is used, displaying the CO concentration and Draft.

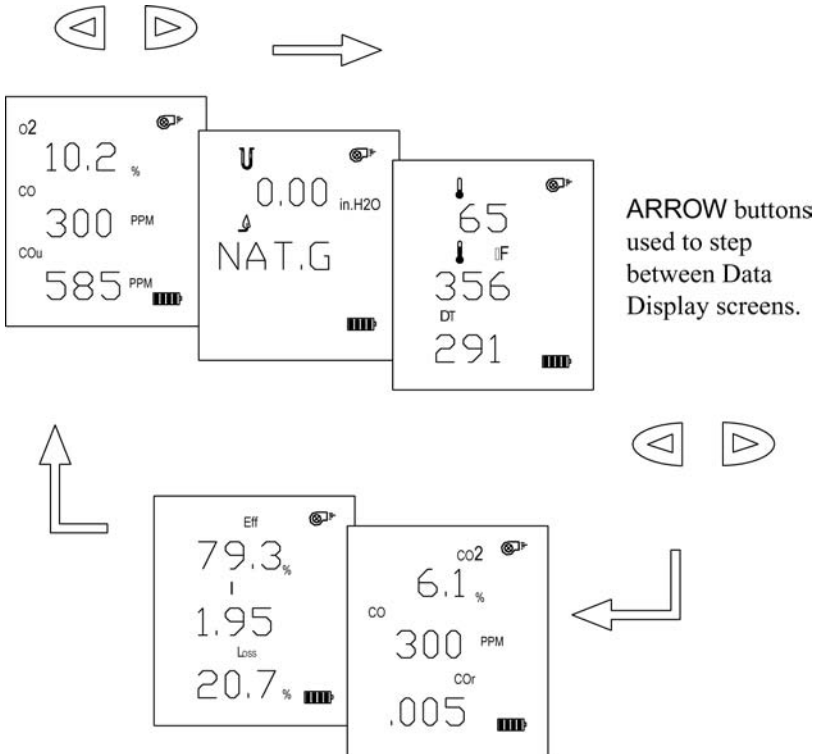

Figure 7. Example Data Displays for a CA-CALC Model CA-6140

Using the Sampling Probe

Gas and Temperature Measurements

Connect the sampling probe to the CA-CALC™ analyzer as described in [Chapter 4](#).

Place the Sampling probe through a hole in the exhaust flue, following recommendations presented below. Placement of the probe is important, and certain considerations must be given when choosing a sampling location.

To ensure that the gas measurements are not diluted or cooled by outside air, place the probe before any draft damper or regulator as illustrated in Figure 8. Tilt the probe tip up slightly so vapor condensing in the sampling tube does not run back to the probe tip and cool the thermocouple tip.

Important: Orient the sampling tube to ensure that the thermocouple tip is exposed directly to exhaust flow (see Figure 8 below).

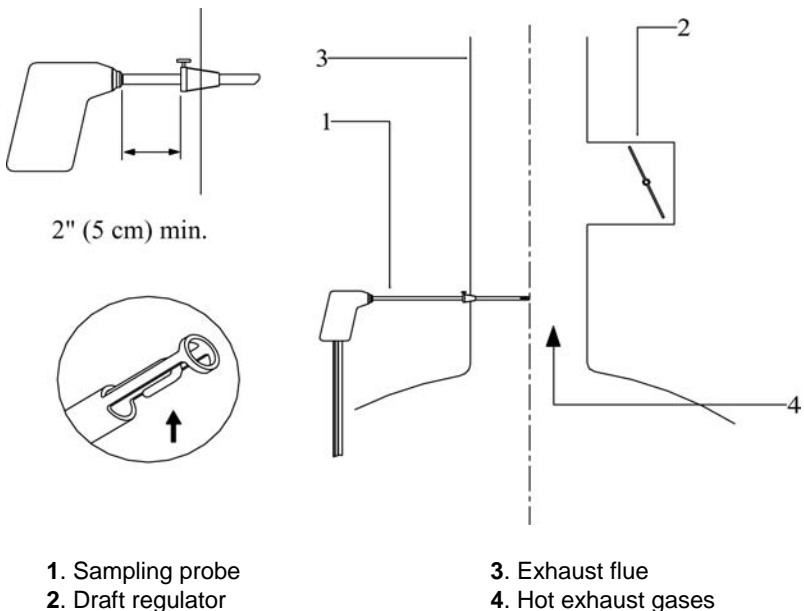



Figure 8. Sampling Probe Location

The sampling probe tip should be placed at the point of highest exhaust gas temperature. This means at the base of the flue, before heat is lost to the flue sidewalls, and towards the center, especially for small ducts. If the flue/stack gas temperature is underestimated, the operating efficiency will be overstated. When an economizer or air heater is used, the flue/stack temperature is measured after these devices.

| | |
|---|--|
|  | <h3>Cautions</h3> |
| | <p>Hot probe! When removed, the sampling probe will be extremely hot. Avoid touching the probe tip, and avoid placing the probe on or near plastic materials such as the instrument case. These will melt. Maintain a minimum 2" (5 cm) clearance between the probe handle and position collar when the probe is mounted in flue.</p> <p>Empty Water Trap! Watch the water trap and empty it frequently to prevent the possibility of flooding the instrument. See Chapter 8 for instructions.</p> |

Draft Measurement (CA-6110, CA-6140)

Whenever the pump is turned OFF, the display screen changes to display the draft reading and the draft icon appears. Turning the pump on with the ON/Off button again causes the draft reading to disappear.

Zeroing the Draft Sensor

For the most accurate draft reading, the draft sensor must be zeroed prior to the draft measurement. To zero the draft sensor, remove the sampling probe from the flue, or separate the sampling tube or tubes from the draft port. Press and hold the PUMP ON/OFF button until the display says "ZERO." Release the button.

Saving Draft

Whenever a sample is saved using the SAVE DATA button, a draft reading is automatically taken. For this to occur, the pump is automatically turned off and a few seconds are allowed for the draft reading to stabilize. Draft is recorded at the end of the data-sampling interval.

Differential Measurement

Instruments with draft measurement capability have two ports to enable differential pressure measurements. The left-side port is the reference

port. When no tube is connected, the draft measurement is referenced to the ambient (room) pressure.

Printing to the Portable Printer and to a Computer (All Models)



Printing to the Portable Printer

Instrument data can be output through the RS-232 serial port to the optional portable printer. First refer to “[Connecting the Optional Portable Printer](#)” in Chapter 4. Make sure the baud rate is set correctly.

To print the information on the Data Display, press the PRINT button. The printer responds immediately once the button is pressed, producing a printout of the current data. An example of this printout is shown in Figure 9.

Saved data can be printed too. Hold the Print button down until a countdown from three (3) begins. Release the button at zero (0), and **all** saved data is printed.

Printing individual saved data samples is described in the next section, “[Handling Data](#).”

Printing to a Computer

Use the PRINT button to output data to a computer as well as to the portable printer. Refer to “[Connecting to a Computer](#)” in Chapter 4.

Data transferred to a computer is the same as that output to a printer (see Figure 9); however, it is formatted differently and uses the Windows® character set rather than DOS characters. You will need to set appropriate COMM MENU option before sending data to the computer. Refer to the Chapter 6, “[MENU Options](#).”

Data can be downloaded to a terminal emulator program such as the **HyperTerminal**, which accompanies the Windows® operating system program. Look for **HyperTerminal** in the **Accessories** folder. In **HyperTerminal**, use the **Capture Text** option from the **Transfer** menu for recording instrument data.

Your instrument comes configured with the following communications protocol.

®Windows is a registered trademark of Microsoft Corporation.

Communications Protocol

| | |
|-----------|----------------|
| Baud rate | 1200 (default) |
| Data bits | 8 |
| Parity | None |
| Stop bit | 1 |
| Flow | None |

```
-----  
MODEL: 6130  
SERIAL: 55030026  
-----  
Current Data  
-----  
DATE: 01/16/06  
TIME: 15:00:18  
Fuel: Nat G  
  
Fuel Parameters:  
Carbon wt.: 75.0 %  
Hydrogen wt.: 25.0 %  
CO2 max vol.: 11.8 %  
Sulfur wt.: 0.0 %  
kBTU/lb: 23.8  
Moisture: 0.0 %  
  
O2:      6.0 %  
CO:      5 PPM  
COu:     7 PPM  
CO2:     8.4 %  
COr :    NA  
TA:      70 °F  
TS:      300 °F  
TS-TA:   230  
EA:      16 %  
Loss:    16 %  
Effc:    84 %
```

Figure 9. Example Printout

Handling Data

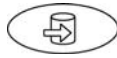

Saving Data

Up to twenty (20) separate measurements can be made and saved to the instrument memory. Data is saved from the Data Display screen by pressing the SAVE DATA button. When SAVE DATA is pressed, measurements are sampled and averaged over the interval set in the [INT.S MENU option](#) described in Chapter 6. As data is sampled, the sample number is displayed, and the save data icon blinks.

Note: The pump turns off while the draft is measured and saved.

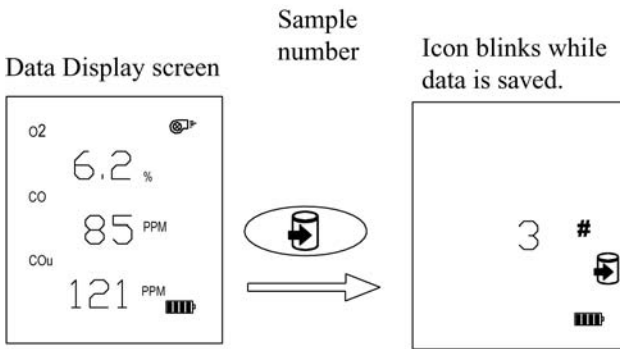

The sampling interval is set from the INT.S MENU option. Data is averaged over this time.

Figure 10. Saving Data Diagram

CLEAR Data

Press the CLEAR DATA button, from the Data Display screen, to erase data Samples saved in instrument memory. To prevent accidentally erasing all your data, the CLEAR DATA button must be held while the instrument counts down from three (3). When the instrument displays zero, release the button and the all data cleared. If the button is held longer, nothing is cleared.

To erase the last Sample only, release the CLEAR data button before zero is displayed, during 3, 2, or 1.

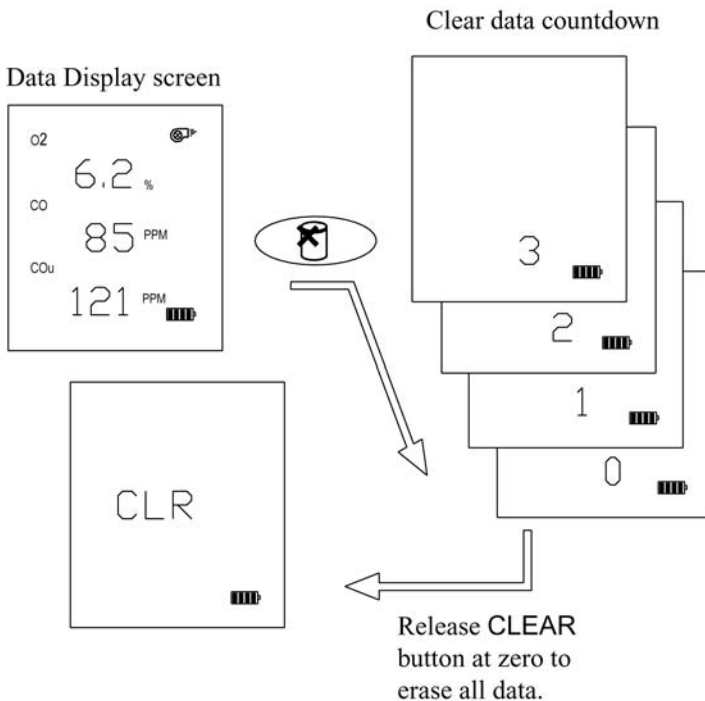

Figure 11. Clearing Saved Data

REVIEW Data Samples



Press the REVIEW DATA button briefly to recall saved Samples. The number of the last Sample appears. Select the specific data Sample you wish to view using the ARROW buttons and press ENTER. When the Sample is displayed, use the ARROW buttons to step through the measurement screens. Review the diagram in Figure 12. You can average data Samples as described in the next section.

Printing

To print individual saved Samples, press the print button while the saved Sample is shown. To print **all** saved Samples, hold the PRINT button down until a countdown from three (3) begins. Release the button at zero, (0) and all saved Samples are printed.

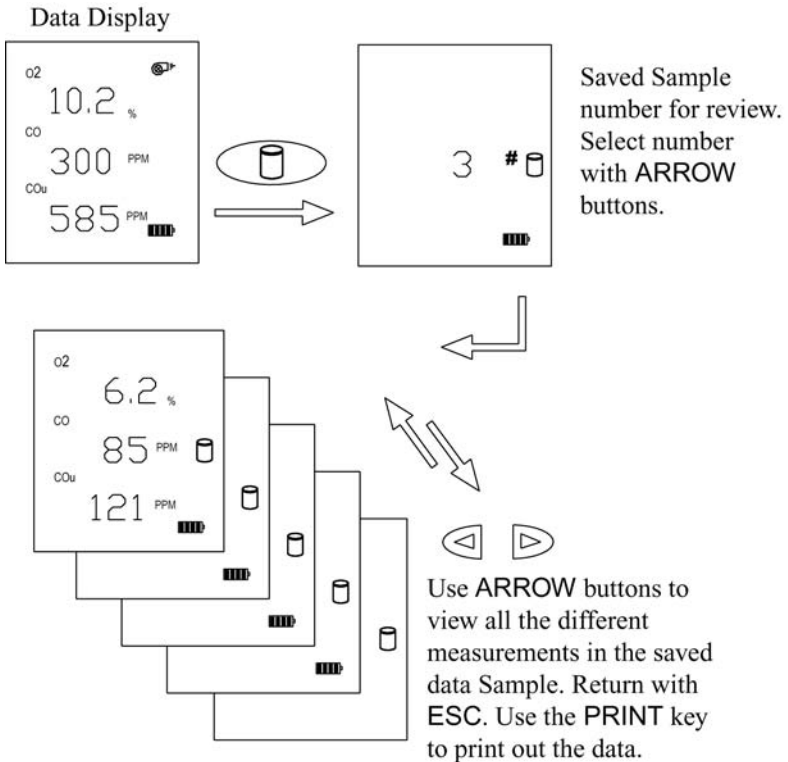

Figure 12. Review Saved Data

Averaging Saved Samples

To average all your saved Samples, press and **hold** the REVIEW DATA button while in the Data Display screen. Hold the button for three seconds. The screen blanks during this interval. The X-bar icon which appears indicates that the data presented is an average of all Samples. See Figure 13.

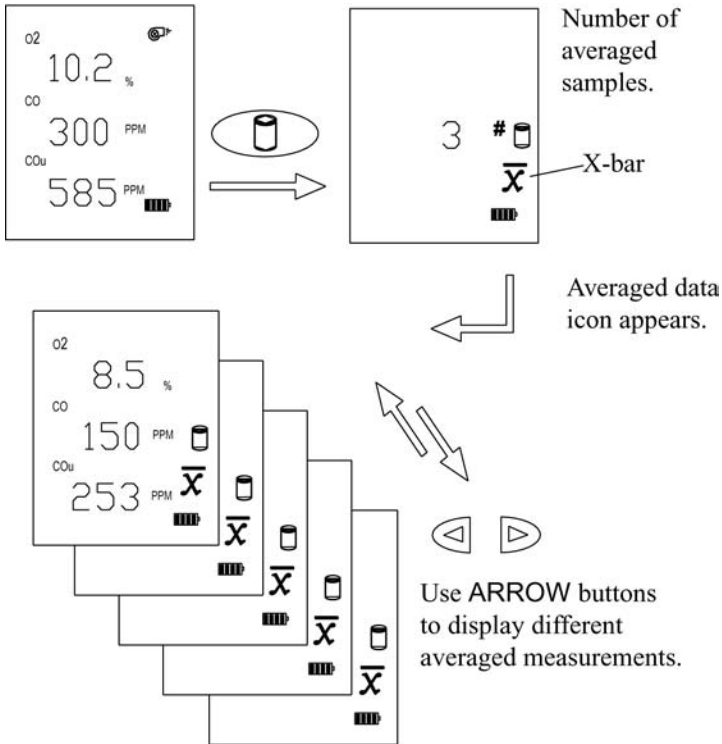

Figure 13. Display of Average of Samples

Chapter 6

MENU Options

The Series CA-6100 CA-CALC™ instrument has a variety of user selectable parameters, available as MENU options. The user-selectable MENU options are shown in the schematic below. Press ENTER to access the MENU options from the Main Data Display screen. View the MENU options by pressing using the ARROW buttons. Once the screen of interest is displayed, press the ENTER button again to choose the MENU option. Refer to Figure 14, which shows the MENU options.

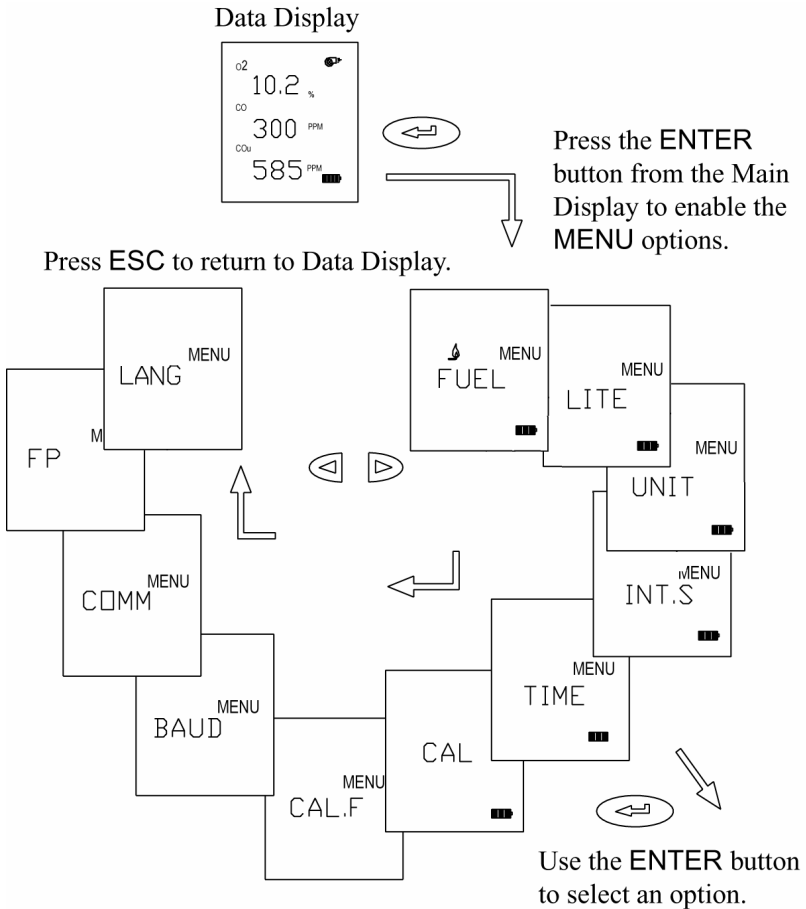

Figure 14. Menu Option

LITE Menu Option

Select the backlight option as ON, OFF or AUTO. Auto turns the backlight on for 60 seconds whenever a button is pressed. Refer to Figure 14, which shows the LITE menu option.

FUEL Menu Option

Use the FUEL option to select from seven preset U.S. fuels or six Siegert fuels, or select the USER fuel. The fuels parameter list presented (U.S. or Siegert), is determined by the LOSS selection (LOSS or qA respectively). For more on fuels, refer to the fuel parameters, FP MENU option in this chapter, and information in [Appendix B](#). Refer to Figure 15, which shows the FUEL menu options.

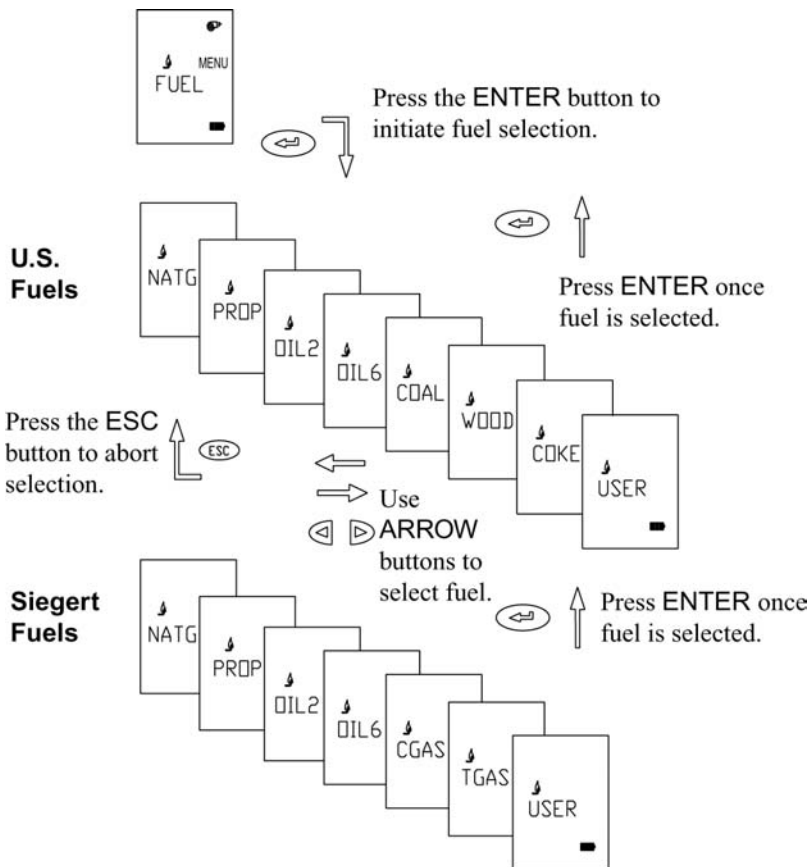

Figure 15. FUEL Options

UNIT Menu Option (Changing Units)

It is possible to display data in different measurement units as indicated in the table below.

Optional Units

| Measurement | UNIT Options |
|---------------------------|---|
| TEMP (temperature) | Degrees F Degrees C |
| GAS (*CO concentration) | PPM mg/m ³ |
| PRES (draft pressure) | In. H ₂ O mbar hPa mm H ₂ O |
| EA (excess air) | % EA λ (Lambda = %EA/100 + 1) |
| LOSS (flue gas heat loss) | Loss (ASME) qA (Siegert) |
| DECI | Period, or comma for decimals |
| DATE | Month/day or day/month format option |

To change units, press the **ENTER** button from the Data Display screen. Using the **ARROW** buttons, find **UNIT** from the **MENU** options. Continue using the **ARROW** buttons to find an option and **ENTER** to activate it. Refer to the example below which diagrams changing units. In this example, CO units are changed.

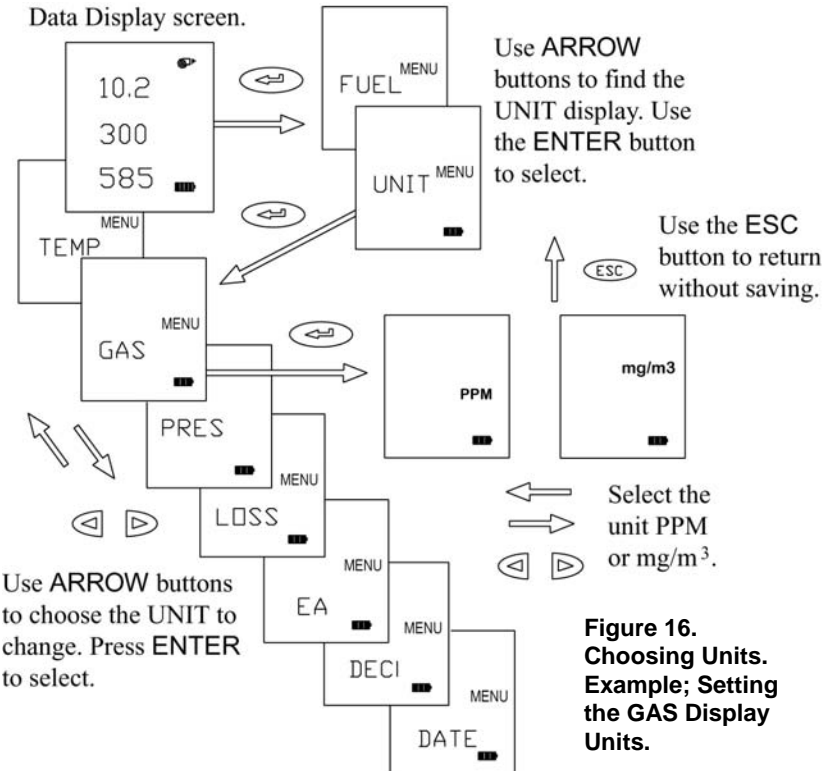

INT.S MENU Option

This option enables you to change the sampling interval over which data is averaged and saved. Use the ENTER button to select. Use the ARROW buttons to choose the sampling interval from the following options 1, 5, 10, 15, 20, 25, and 30. These represent the number of discrete data values taken each second and averaged. Use the SAVE DATA button to begin sampling.

TIME MENU Option (Set Time and Date)

Press the ENTER button when the TIME MENU item is displayed. Use the ARROW buttons to select the field to be changed. The field will blink as it is highlighted by the ARROW button. To change, press ENTER again. Use the ARROW buttons to increase or decrease the value selected. Press ENTER to install the new value. Press ESC to abort and return to the previous screen.

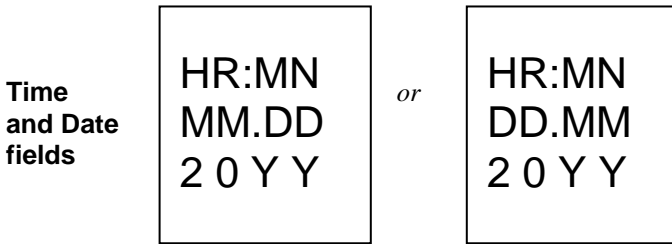

CAL MENU Option

The CAL option is used for performing calibrations of the on-board sensors. When this option is chosen using the ENTER button, characters and icons associated with the installed sensor will be displayed, one at a time. Press an ARROW button and scroll through the options until the desired sensor for calibration appears. Press ENTER to begin the calibration process. Refer to Figures 17, 18, and 19, for schematic representations for calibration of the electrochemical sensors, draft sensor and temperature sensors.

O₂ Gas Sensor Calibration (CA-6120, CA-6130, CA-6140)

Select CAL from the MENU options using the ENTER button. Select the O₂ icon from the icons displayed using an ARROW button and press ENTER. Attach the zero gas (nitrogen, N₂) to the sampling probe as described in Chapter 7, “[Setup for Gas Calibration](#).” When ready, press ENTER to begin the zero calibration. Once complete, the SPAN calibration screen appears. The O₂ concentration can be adjusted using the ARROW buttons. If room air is used as the calibration gas, do **not** change the 20.9% value displayed.

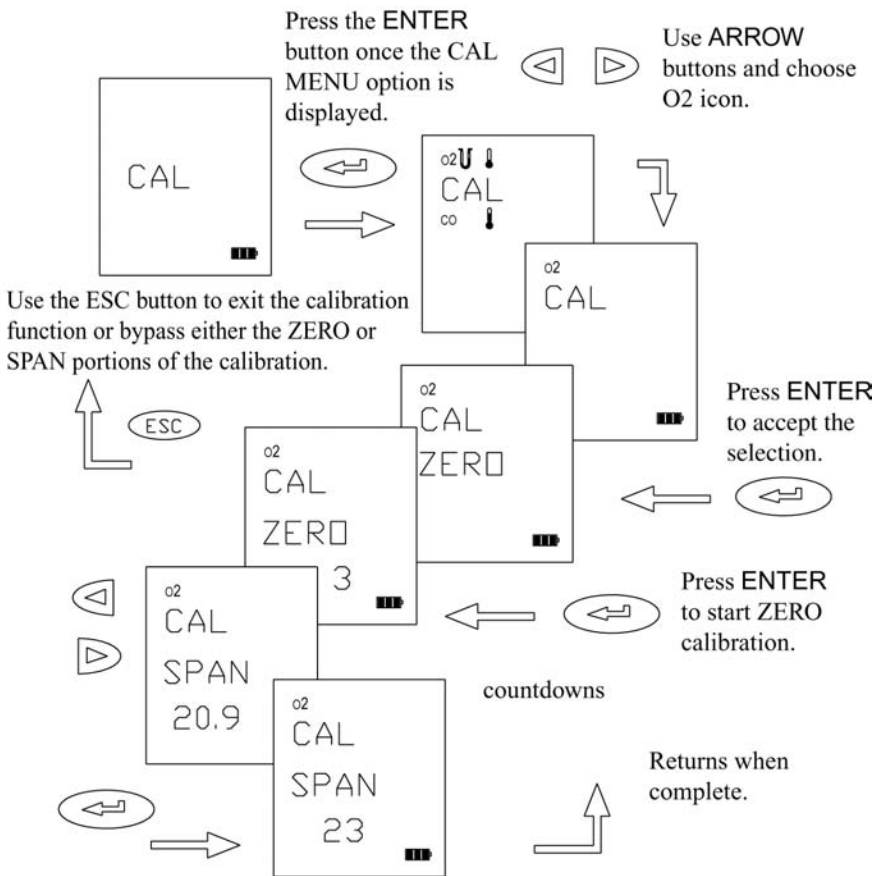

Use the ARROW buttons to match the calibration gas concentration. If the ambient air is used, make sure the setting is 20.9% as shown.

Press ENTER button to begin the SPAN calibration.

Figure 17. O₂ Sensor Calibration Sequence

CO Sensor Calibration (CA-6110, CA-6130, CA-6140)

Select CAL from the MENU options by pressing ENTER. Select the CO icon from the icons displayed using an ARROW button and press ENTER. For the zero calibration, find a location free of CO. When ready, press ENTER to begin the zero calibration. Once complete, the SPAN calibration screen appears. Connect your calibration gas to the sampling probe as described in Chapter 7, “[Setup for Gas Calibration.](#)” Adjust the CO concentration in the span screen, using the ARROW buttons, so it matches your calibration gas bottle concentration. Press the ENTER button to start the calibration.

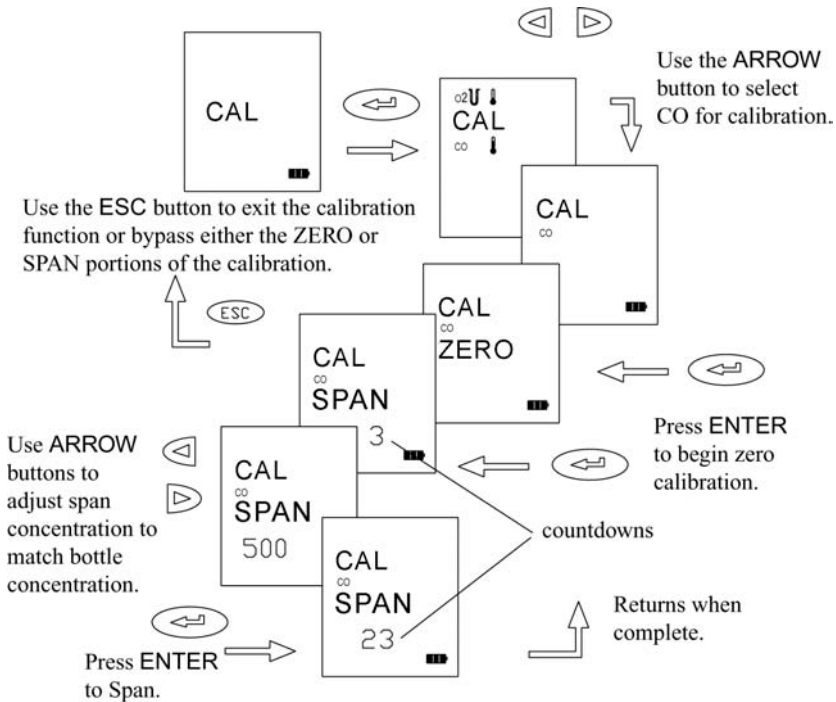

Figure 18. CO Calibration

Draft Calibration (CA-6110, CA-6140)

Span calibration of the draft sensor is normally not required. The draft sensor should be routinely zeroed however, to compensate for the effects of temperature on sensor signal, and to correct for normal drifts in sensor zero voltage over time. As described earlier in the manual, zeroing the sensor is achieved simply by holding the pump ON/OFF button down for three seconds. This should be done prior to any pressure measurement. This is especially important when the draft pressure is small.

The schematic below outlines the steps in performing a draft calibration. As with other calibrations, select the draft icon using the arrow buttons. Begin the calibration by pressing the ENTER button to perform a calibration zero. When the zero is complete, use the arrow buttons to select your supply reference pressure. Press ENTER to initiate the Span calibration. Both plus and minus pressures are calibrated by applying the same **positive** pressure to both the *right* then *left* draft sample ports in turn.*

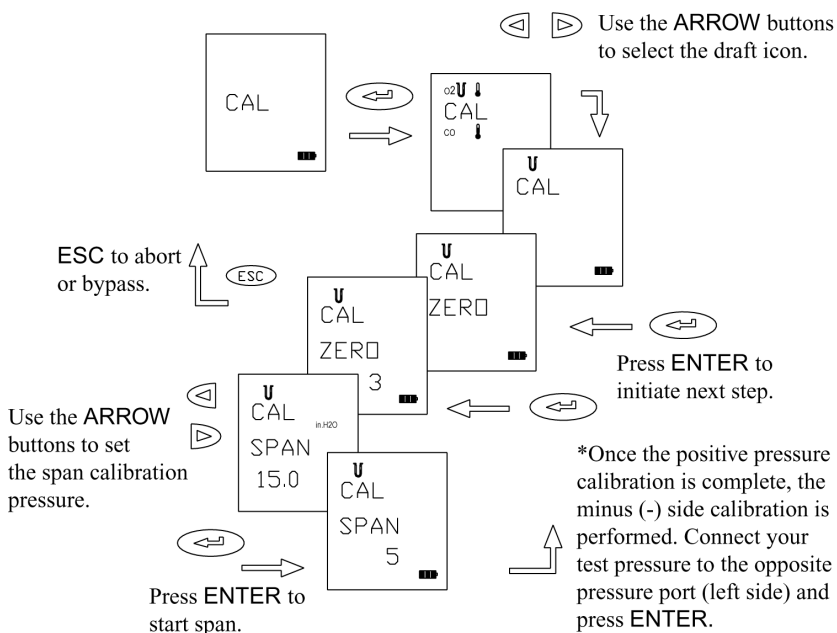

Figure 19. Draft Calibration

Temperature Calibration (CA-6120, CA-6130, CA-6140)

Calibration of the thermocouple temperature sensors is not recommended. Thermocouple sensors are very repeatable, so even if a replacement is required, or a combustion air temperature probe is purchased as an accessory, it is unnecessary to calibrate it. Calibration of a thermocouple probe has value if a narrow temperature range is used, and calibration is performed in that range. The burden is left to you to provide an accurate temperature reference. Refer to the steps diagrammed below if calibration of a thermocouple is desired.

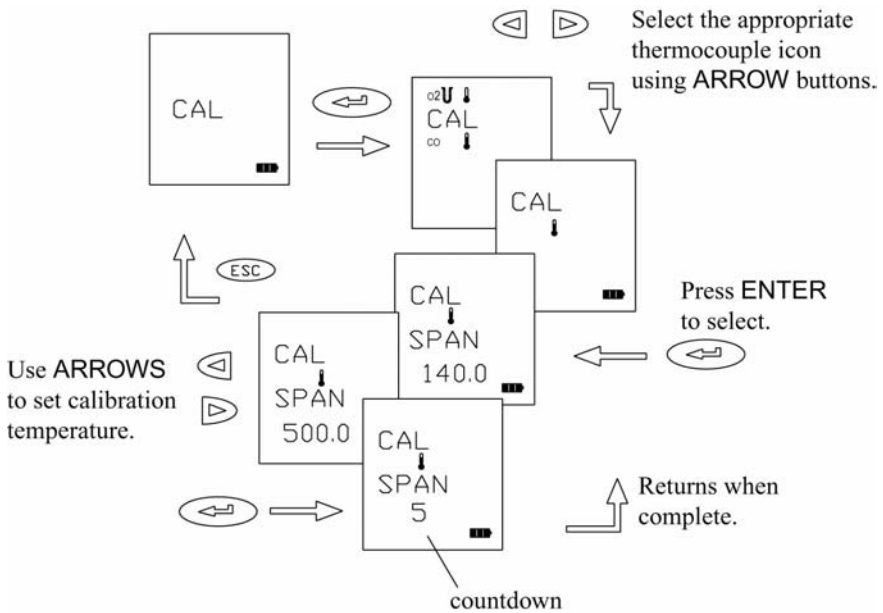

Figure 20. CO Calibration

CAL.F MENU Option—Setting the Calibration Factor

When you install a replacement CO sensor from TSI, you will enter a new calibration factor. This factor is determined by a sensor calibration at the factory.

After installing your new sensor, as described in Chapter 8, “[Maintenance and Troubleshooting](#),” find the calibration factor sheet. Use the MENU option CAL.F, and enter calibration factor provided. Refer to the details outlined in the schematic below.

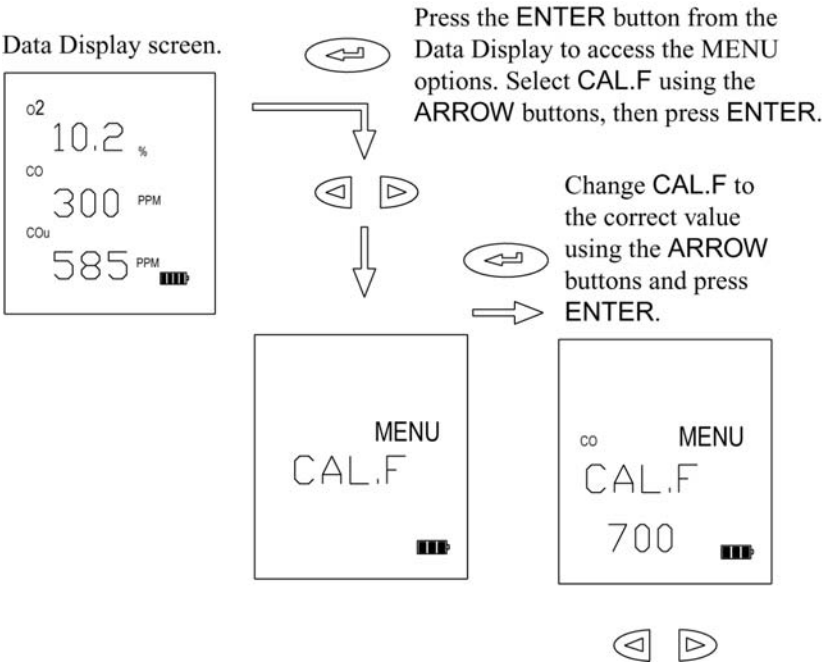

Figure 21. Setting the Calibration Factor

BAUD Rate MENU option

Baud rate can be set to match your computer or portable printer. Your instrument is delivered with a default baud rate of 1200.

Baud rate values are displayed in the BAUD rate option divided by 1000. The following baud rates can be set. 1.2 (1200), 2.4 (2400), 4.8 (4800), 9.6 (9600), 19.2 (19200).

To set the baud rate follow the steps outlined in the schematic shown below in Figure 22.

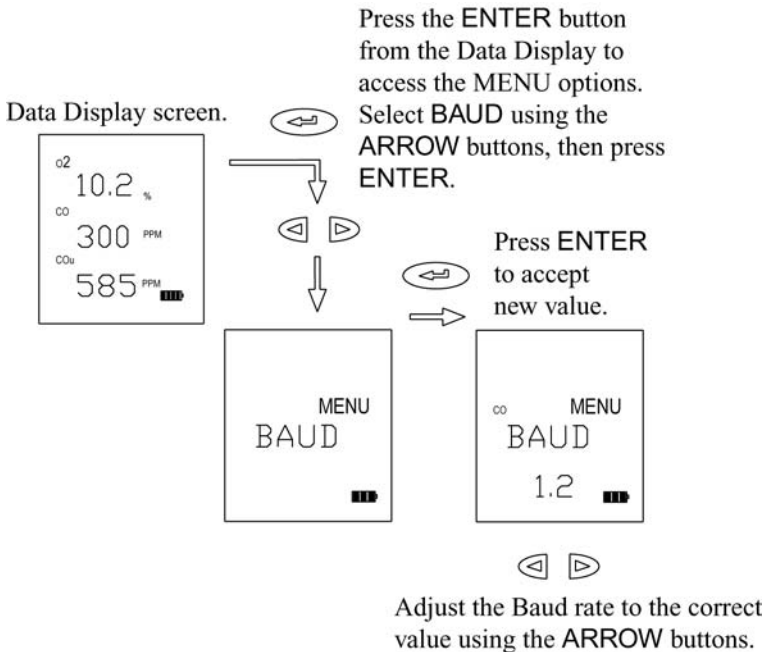

Figure 22. Setting the Baud Rate

COMM MENU Option—Set the Output Communications Device

Your CA-CALC™ analyzer transfers current or saved data to a serial printer or computer. The COMM MENU option is used to select the device that you want to communicate with.

To set the device, follow the steps outlined in the schematic shown below in Figure 23.

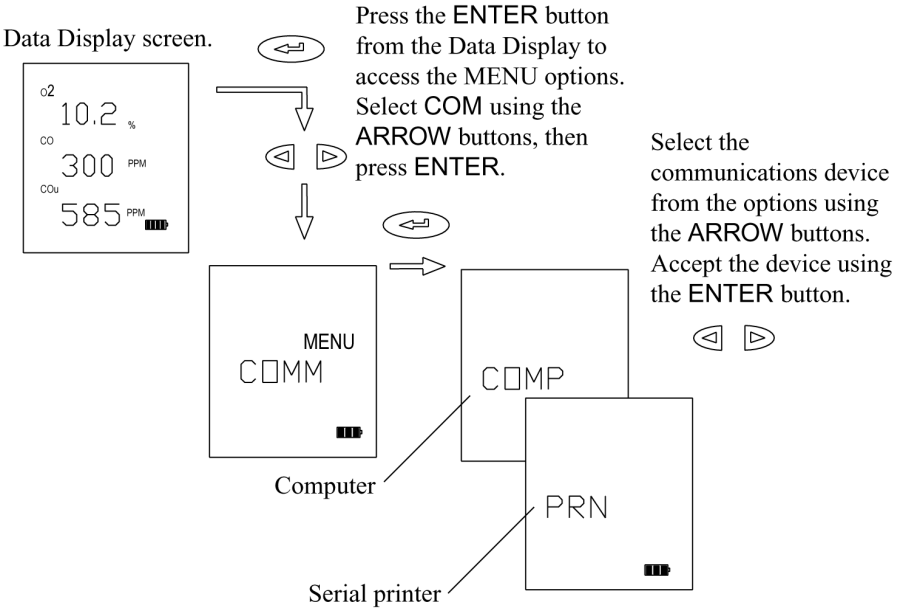

Figure 23. Setting the Data Output Device

FP MENU Option—Fuel Parameters (CA-6120, CA-6130, CA-6140)

U.S. Fuel Parameters

For U.S. fuels, and U.S. Fuel Parameters to be displayed, the fuel heat LOSS selection must be set to LOSS, not qA. Refer to the section “[UNIT Menu Option \(Changing Units\)](#)” in this chapter.

For calculations of flue losses, maximum %CO₂, fuel composition and fuel heat content are used. These are the Fuel Parameters. In your CA-CALC™ analyzer, U.S. fuel parameters are the carbon and hydrogen content, moisture content, sulfur content, and maximum %CO₂, C2MX.

Refer to the diagrams (Figures 24 and 25) and table below, for information on viewing and changing fuel parameters.

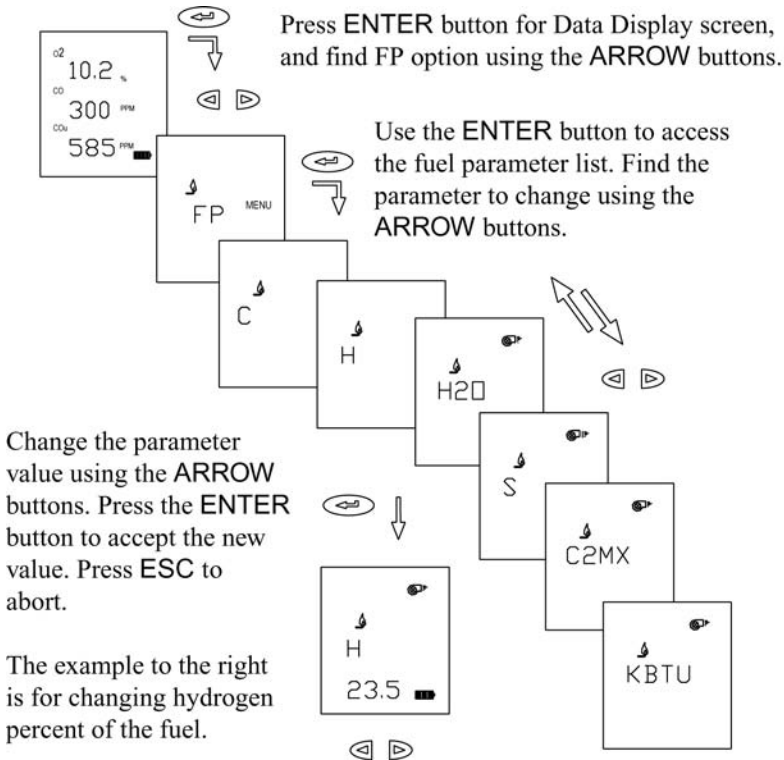

Figure 24. Fuel Parameters for U.S. Fuels

Your CA-CALC™ analyzer has parameters for seven common U.S. fuels in instrument memory. Fuel parameters for these fuels can be changed, if you know, for example, that your fuel has a different composition than that stored. The instrument fuel parameters values are presented in Appendix B, with additional technical information.

Fuel Parameter Descriptions for U.S. Fuels

| Fuel Parameter | Description |
|------------------|------------------------------|
| C | % carbon by weight |
| H | % hydrogen by weight |
| H ₂ O | % water content by weight |
| S | % sulfur by weight |
| C2MX | CO ₂ max % |
| KBTU | Heating value in kiloBTUs/lb |

FP Fuel Parameters for Siegert Calculation—Siegert Fuel Parameters

For the Siegert fuels and Siegert Fuel Parameters to be displayed, the fuel heat LOSS selection must be set to qA, not Loss. Refer to the section [UNIT Menu Option \(Changing Units\)](#) in this chapter.

The Siegert value for flue loss, given the designation qA, is used widely in Europe. Two coefficients are used in the Siegert formula for flue loss, derived from typical fuel compositions. These are given the designations, A2 and B.

The default Siegert coefficient values in your CA-CALC™ analyzer, are those used in Germany. Siegert coefficients used in other countries may be different, reflecting differences in local fuel compositions.

Note: *A2 is sometimes defined differently. A2 values entered by the user must be appropriate for the Siegert equation presented in [Appendix B](#).*

Figure 25 diagrams the steps in changing the Siegert fuel parameters.

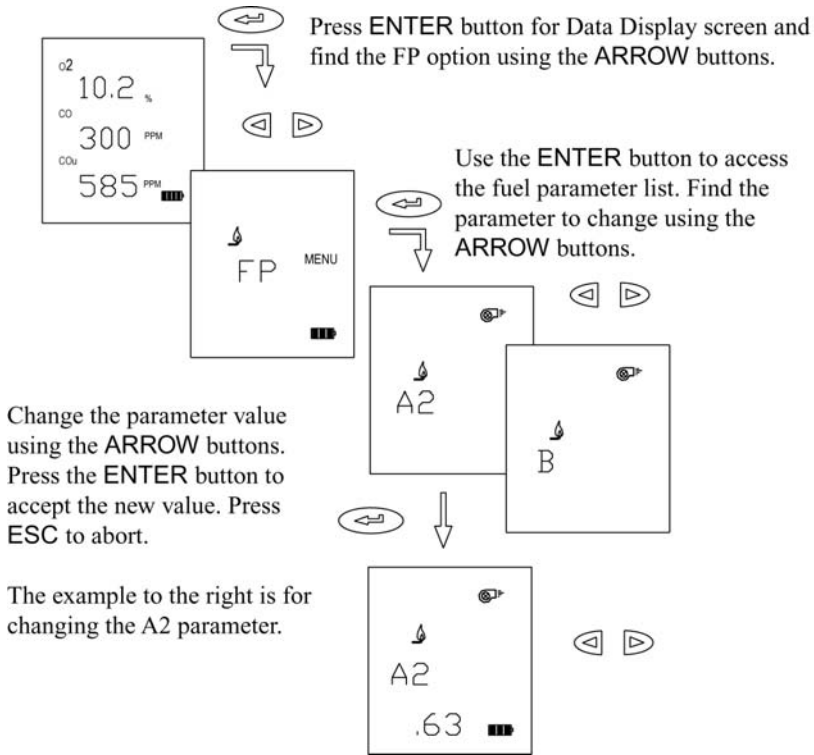

Figure 25. Changing Fuel Parameters for Siegert Fuels

LANG MENU Option

Use this option to select between the following languages: **E** English, **D** German, **N** Dutch, **FI** Finnish, **I** Italian or **S** Swedish. English is the language (*default*) initially installed on the instrument.

When the language is changed, instrument settings are automatically changed too. Refer to Chapter 4 “[Default Instrument Settings](#)” for more information on this feature.

Chapter 7

Setup for Gas Calibration

The Calibration Setups

Note: To perform your gas sensor calibration, you will also need to refer back to Chapter 6, and the section, "[CAL MENU Option](#)."

CO and O₂ gas sensors can be calibrated periodically to maintain the accuracy of these gas measurements. Gas sensors do drift over time, depending upon the operating environment and gas exposure history.

With the proper equipment, such as that shown in the figures below, it is easy to calibrate your CA-CALC™ analyzer gas sensors. However, if you wish, you may also return your instrument to TSI for a new *factory* calibration.

The equipment needed to calibrate individual gas sensors can be purchased from TSI as calibration kits. Model numbers for these kits are found in Chapter 2, "[Unpacking](#)." You may also elect to put together your own calibration system. Two calibration setups are presented in Figures 26 and 27. A brief discussion of these calibration setups is presented in the following section.

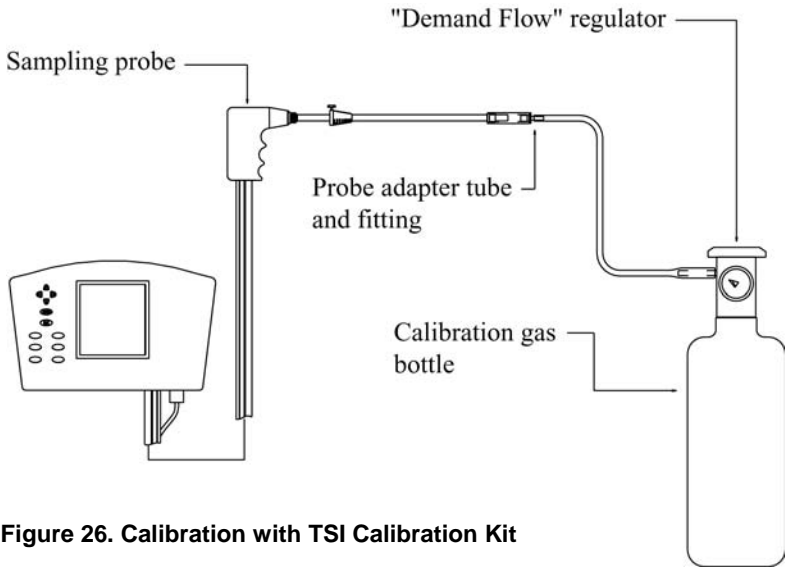

Figure 26. Calibration with TSI Calibration Kit

A TSI supplied calibration kit (Figure 26) uses a *demand flow* regulator to supply gas to the CA-CALC™ analyzer in response to the draw of the instrument sampling the pump. If a conventional regulator and valve are used (Figure 27), the setup supplies gas to the instrument using a tee to a bleed-off extra gas. This prevents a forced flow at the instrument inlet. The bead-type flow meter depicted in the figure is used to verify there is extra flow (.5 to 2 L/min recommended). Extra flow is required to prevent room air from being drawn in, diluting the sample.

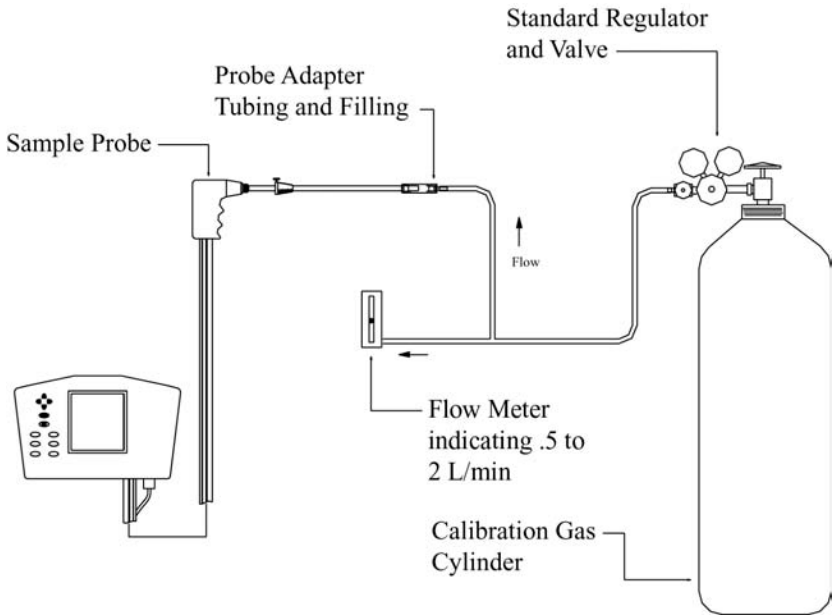

Figure 27. Alternative Calibration Setup

(This page intentionally left blank)

Chapter 8

Maintenance and Troubleshooting

For additional troubleshooting information, please visit TSI's website <http://combustion.tsi.com>.

Emptying Water Trap

Refer back to Figure 2 showing the water trap in the sample line, and to Figure 28 below. Liquid water forms in the first chamber of the water trap as gases are sampled from the flue. The water trap is designed so even when shaken, or when its orientation is changed, water does not pass to the second chamber. The water level must remain below the level depicted in the figure, however.

To empty the water trap:

1. First separate it from the sampling tube by pulling the tube ends off the barbs on the end caps.
2. Remove the probe side end cap by pulling outward with a twisting motion.
3. Pour out the water.
4. Replace the end cap and re-install the trap.

Important: Make sure the water trap is oriented so that end-cap 1 below is toward the instrument.

Changing the (optional) Water Trap Filter

Identify the water trap filter (refer to Figure 28). This filter is designed to remove soot particles before they contaminate the instrument. The filter can be removed for cleaning or replacement by following these steps:

1. Remove the instrument side end cap by pulling it out with a twisting motion.
2. Grasp the filter using a needle-nose pliers and pull it out.
3. To clean the filter, remove the bulk of the soot by tapping the filter. The soot may be removed by rinsing with water or isopropyl alcohol. The effectiveness of the rinse depends on the soot composition—is it dry or oily. Avoid rubbing, which may drive contaminants into the filter causing permanent plugging.

- Whether cleaned or replaced, install the filter by pushing it over the stub in the filter body, then replace the end cap.

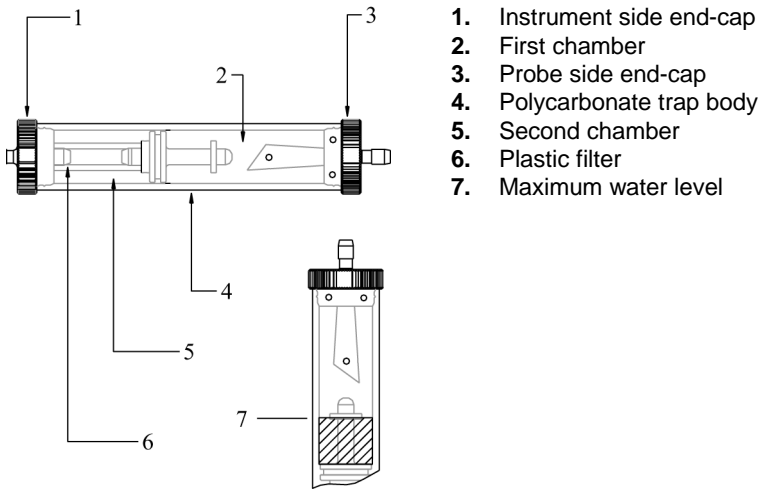

Figure 28. In-line Water Trap

Cleaning the Sample Probe

Cleaning may be necessary in high-soot environments. Soot accumulates in the steel sampling tube and sampling line and over time may contribute to a blocked flow path.

- Remove the water trap by separating the sample tube from the tube stub on each end of the trap.
- Rinse the tubing, allowing the water to drain from the probe end. When the water is clear, discontinue the rinse. Orient the probe and tubing so excess water drains from the sample lines.
- Allow adequate time for the interior of the probe to dry. Replace the water trap making sure the water trap is oriented properly. The filter must be toward the instrument.

Installing a Gas Sensor

- Remove the sensor cover shown in Figure 29 below, by removing the sensor cover screw.
- Carefully lift the rubber sensor manifold from the sensor(s) and bend it back. Do **not** attempt to remove the rubber manifold from the case!

Changing the O2 Sensor

- Refer to Figure 29. Pull the O2 sensor straight up to remove.

2. Note the configuration of the sensor pins on the new sensor and match with the pin receptacles on the instrument electronics board.
3. Carefully install the new sensor, pushing down gently.
4. Replace the rubber manifold by pushing the gasket over the sensor(s).

Installing a New CO Sensor

1. If installing a new CO sensor, pull the sensor together with the foam gasket out of the instrument, or remove the sensor plug if upgrading from a Model CA-6120 to Model CA-6130.
2. Remove the gasket from the sensor.
3. Replace the gasket in the rubber sensor manifold by aligning the notch in the gasket with the alignment tab on the manifold (see Figure 29).
4. Install the new sensor by aligning the pins on the sensor with those on the instrument electronics board.
5. Replace the sensor manifold, pushing the foam gasket over the new CO sensor until it is fully seated.

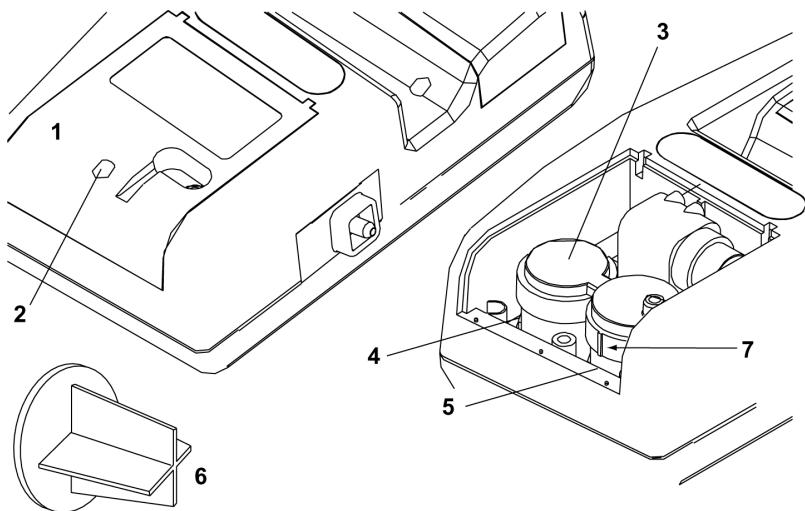

- | | |
|---------------------------|------------------|
| 1. Sensor cover | 5. CO sensor |
| 2. Cover retaining screw | 6. Sensor plug |
| 3. Rubber sensor manifold | 7. Alignment tab |
| 4. O ₂ sensor | |

Figure 29. Removing and Replacing CO and O₂ Sensors

6. When installing a replacement sensor from TSI, you will receive a data sheet with a sensor calibration *factor*. Once your replacement sensor has been installed, enter this value through the [CAL.F MENU option](#) described in Chapter 6.

Adding a CO Sensor to the Model CA-6120

For instrument firmware versions higher than H.O (version displayed during instrument start-up), it is possible to add a CO sensor to your Model CA-6120, upgrading it to a Model CA-6130. For the upgrade, a calibrated CO replacement sensor must be purchased from TSI (TSI P/N 802006).

1. Install your new CO sensor as described in the previous section of this manual “[Installing a New CO Sensor](#).” Sensor installation instructions are also provided on the supplied CD and online at www.tsi.com.
2. Turn the instrument ON.
3. During the 30 second WARM-UP interval, depress and hold the print and save buttons (see below) together for at least three (3) seconds to enter the CO sensor selection screen.

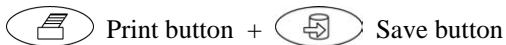

4. From the CO selection screen, choose **On** using the arrow buttons. Press the **ENTER** button to accept the selection. The instrument automatically turns off.
5. Turn the instrument ON. The new sensor may cause an ERR (error) message the first time. Bypass the message using the **ESC** button.
6. After the startup sequence completes, key-in the sensor *calibration factor* provided with the CO sensor using the instructions in the [CAL.F MENU option](#) described in Chapter 6.

Disabling CO Sensor Recognition by a Model CA-6130

It is possible to disable CO sensor recognition by your Model CA-6130 instrument, downgrading to a Model CA-6120. Refer to the instructions above for adding a CO sensor. When the CO selection screen appears, select **Off** (rather than **On**) and press the **ENTER** button.

Important: The CO sensor should **not** be removed unless replaced with a plastic sensor plug (see Figure 29).

Appendix A

Error Codes

Note: An Error Code can be bypassed using the ESC button.

6. Lithium battery low.
7. Error in logged data.
9. Can't save data to EEPROM.
10. An invalid fuel type was corrected.
11. An invalid fuel parameter was corrected.
12. Model number checksum error.
13. TA thermocouple checksum error.
14. TS thermocouple checksum error.
15. Draft sensor checksum error.
16. A/D calibration checksum error.
17. CO sensor checksum error.
18. O₂ sensor checksum error.
19. The pump current is too high.
30. O₂ gain calibration factor out of range.
31. CO gain calibration factor out of range.
32. TA gain calibration factor out of range.
33. TS gain calibration factor out of range.
34. A/D converter calibration factor out of range.
35. CO zero calibration factor out of range.
50. O₂ zero voltage out of range.
51. CO zero voltage out of range.
52. TA temperature out of range.
53. TS temperature out of range.
54. Instrument temperature out of range.
55. Draft zero voltage out of range.
56. Draft span calibration out of range.
57. O₂ span voltage out of range.
71. (or higher) Internal program error—contact TSI.

(This page intentionally left blank)

Appendix B

Calculations

CO_u Undiluted CO Concentration Calculation

$$CO \text{ undiluted} = CO_{\text{measured}} (PPM) \times \frac{20.9}{20.9 - O_2 \text{ measured}}$$

Excess Air Calculation

$$\% \text{ Excess Air} = \frac{\%O_2 - \%CO/2}{20.9 - (\%O_2 - \%CO/2)} \times 100$$

Another expression of excess is λ (Greek letter Lambda) also used. The relationship between % EA and Lambda is shown below:

$$\lambda = \frac{\%EA}{100} + 1$$

Calculating Combustion Efficiency for U.S. Fuels

Net combustion efficiency (Effic Net)

$$\% \text{ Combustion Efficiency} = 100 - \frac{\text{fuel heat losses}}{\text{fuel heating value}} \times 100$$

$$\begin{aligned} \text{flue heat losses} = & \text{heat loss from dry gas} \\ & + \text{heat loss due to moisture from burning} \\ \text{hydrogen} & \\ & + \text{heat loss due to moisture in fuel} \\ & + \text{heat loss from the formation of CO} \end{aligned}$$

Heat losses are per unit weight of fuel
Fuel heating value: HHV or LHV (high heating and low heating, respectively).

This basic method is described in the ASME (American Society of Mechanical Engineers) Power Test Code 4.1. Note, however, the calculation of *Combustion Efficiency* considers only flue losses. In ASME PTC 4.1 losses from other sources (e.g. radiation, convection) are also considered.

Fuel Parameters for U.S. Fuels

| Fuel Parameters | NATG, Methane | PROP, Propane | OIL2, Oil #2 | OIL6, Oil #6 | COAL | WOOD | COKE |
|---------------------|---------------|---------------|--------------|--------------|-------|------|------|
| %Carbon | 75 | 81.8 | 85.84 | 87.49 | 94.5 | 51.8 | 98.2 |
| %Hydrogen | 25 | 18.18 | 12.46 | 9.92 | 5.2 | 6.3 | 1.5 |
| BTU/lb HHV | 23800 | 21600 | 19500 | 18300 | 13400 | 9100 | 16.5 |
| CO ₂ max | 11.8 | 13.8 | 15.6 | 16.5 | 17 | 19.1 | 20.1 |
| %Sulfur | 0 | 0 | 1.6 | 1.40 | 0.034 | 0 | 0 |
| %Moisture | 0 | 0 | 0 | 0 | 0.12 | 0 | .5 |

Siebert Formula

This formula is widely used in Europe to determine flue gas losses (qA) and efficiency.

$$qA = (T_s - T_a) \times \left(\frac{A_2}{(21 - O_2)} + B \right)$$

$$\text{Efficiency} = 100 - qA$$

where:

qA = dry gas losses

T_s = flue temperature

T_a = supply air temperature

O_2 = measured volumetric oxygen concentration expressed as a percent

A_2, B = fuel dependent constants

The constants A_2 and B are based on the composition of combustibles in the fuels. In Germany, the following prescribed values are provided for common fuels.

Fuel Parameters for Siebert Fuels

| Fuel Type | A ₂ | B |
|-----------------------|----------------|------|
| NATG, Natural gas | .66 | .009 |
| OIL2, light fuel oil | .68 | .007 |
| OIL6, heavy oil | .68 | .007 |
| TGAS, Town gas | .63 | .011 |
| CGAS, Coking oven gas | .60 | .011 |
| PROP, propane | .63 | .008 |

Determining CO₂ Using the O₂ Concentration

$$\% \text{CO}_2 \text{ (by volume)} = \text{CO}_2 \text{ max} \times \frac{(20.9 - \% \text{O}_2 \text{ measured})}{20.9}$$

CO₂max is the theoretical maximum concentration produced for the fuel used.

where:

E = Emission Rate (pounds/MBtu of fuel)

C_g = Gas Concentration (PPM)

F_t = factor from Table I (below)

O₂ measured = Oxygen concentration from flue measurement (%)

A General Equation for the Combustion of a Simple Hydrocarbon in Air

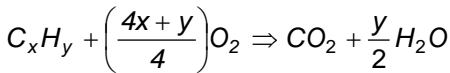

x and *y* are the number of atoms of carbon and hydrogen in the fuel molecule.

Calculating CO₂ Max From the Carbon Content

$$\% \text{CO}_2 \text{ max} = \frac{\text{moles CO}_2}{(\text{moles CO}_2 + \text{moles N}_2)} \times 100$$

$$\text{moles CO}_2 = x \text{ moles}$$

$$\text{moles N}_2 = \frac{(4x + y) \times 3.76}{4}$$

Calculation of Combustion Air Requirement

$$\text{Pounds Air / Pound Fuel} = 11.5C + 34.3(H_2 - O_2/8) + 4.3S$$

C, *H₂*, *O₂* and *S* are the fractions, by weight, of each chemical constituent of the fuel.

(This page intentionally left blank)

Power Requirements:

Batteries:..... 4 AA cell alkaline batteries

Battery life:>10 hours (pump on)

AC Adapter: Use only TSI-supplied adapter (optional
accessory available from TSI)

Backup battery:Lithium

Backup battery life:..... 3 yrs

Note: These specifications assume the instrument is allowed to stabilize at the operating temperature before being turned on.

TSI Incorporated – 500 Cardigan Road, Shoreview, MN 55126 U.S.A

| | | | |
|-----------|-----------------------|--|---|
| USA | Tel: +1 800 874 2811 | E-mail: info@tsi.com | Website: www.tsi.com |
| UK | Tel: +44 149 4 459200 | E-mail: tsiuk@tsi.com | Website: www.tsiinc.co.uk |
| France | Tel: +33 491 11 87 64 | E-mail: tsifrance@tsi.com | Website: www.tsiinc.fr |
| Germany | Tel: +49 241 523030 | E-mail: tsigmbh@tsi.com | Website: www.tsiinc.de |
| India | Tel: +91 80 41132470 | E-mail: tsi-india@tsi.com | |
| China | Tel: +86 10 8251 6588 | E-mail: tsibeijing@tsi.com | |
| Singapore | Tel: +65 6595 6388 | E-mail: tsi-singapore@tsi.com | |



Contact your local TSI Distributor or visit our website www.tsi.com for more detailed specifications.