



Installation Guide

"Multi-Sense" Model 260 Series

Multi-Range Differential Pressure Transducer



MECHANICAL INSTALLATION

Mounting Position

Mount and calibrate in vertical position for quick and easy installation on ducts, walls or ceilings and in control rooms.

Media Compatibility

Model 260 transducers are designed to be used with air or nonconducting gases. Use with liquids or corrosive gases will damage the unit.

Environment

The operating temperature limits of the 260 are as follows:

Operating Temperature 32°F to 122°F (0°C to 50°C)
 Compensated Temperature Range 32°F to 122°F (0°C to 50°C)

SIMPLE 5-STEP SETUP INSTRUCTIONS - STEP 1

For CE compliance a properly grounded shielding cable is required.

ELECTRICAL CONNECTIONS

Removable Terminal Block for Easy Wiring

STEP 1: Wire and Power Up Unit - Follow diagrams below for 2-wire and 3-wire configurations. After completing wiring requirements - Apply power to the Model 260.

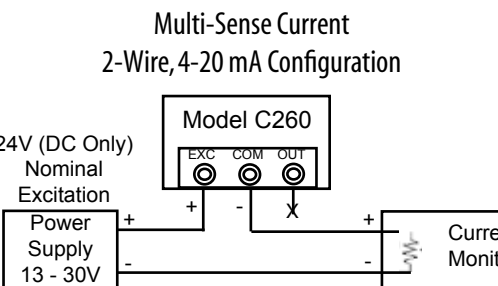
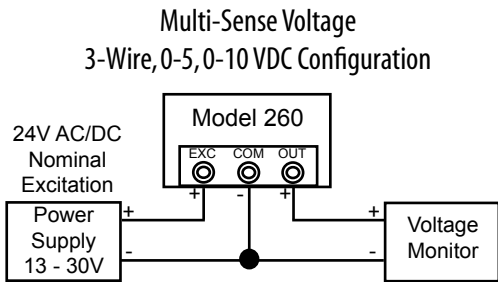

GENERAL INFORMATION

Every Model 260 has been calibrated and tested before shipment to guarantee performance for all pressure ranges.

The Model 260 is available in four versions, which have field selectable range capability via a slide switch. See four versions below:

MULTI-SENSE RANGE SPECIFICATIONS

Version	Ranges	
	Unidirectional	Bidirectional
Model MS1	0.1", 0.25", 0.5" and 1.0" W.C. FS	+/- 0.1", 0.25", 0.5" and 1.0" W.C. FS
Model MS2	1.0", 2.5", 5.0" and 10" W.C. FS	+/- 1.0", 2.5", 5.0" and 10" W.C. FS
Model MS3	25, 50, 100 and 250 Pa FS	+/- 25, 50, 100 and 250 Pa FS
Model MS4	.25, .50, 1.00 and 2.5 kPa	+/- .25, .50, 1.00 and 2.5 kPa

The Model 260 is available in three field selectable output configurations. See three versions below:

2-Wire	4-20 mA (Current)
3-Wire	0-5, or 0-10 VDC (Voltage)

SIMPLE 5-STEP SETUP INSTRUCTIONS - STEPS 2 - 5

Power On - LCD Display

Display momentarily toggles thru all existing setup parameters on initial power up. Pressure is normally indicated on display. Units are either in inches of water column (WC) MS1 & MS2, or Pascal (Pa) MS3 & MS4.

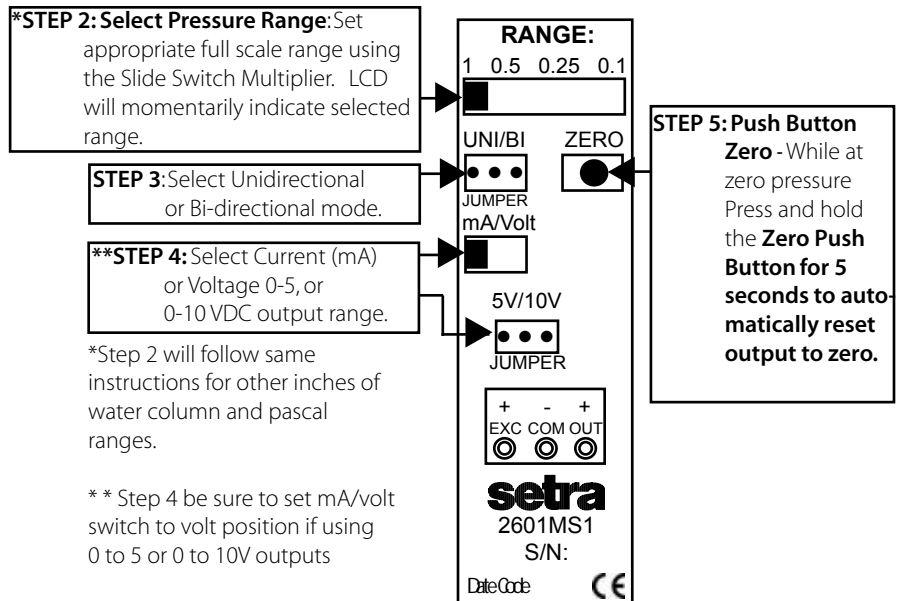

ZERO AND SPAN ADJUSTMENT*

The unit may be recalibrated in the field using the push button zero/span.

Zero Adjustment:

1. With unit at zero differential pressure, push zero button for 5 seconds. Units output and display will update.

Span Adjustment:

2. Apply full scale pressure (Note: Full scale value of largest range). Press and hold zero button for 5 seconds. Units output and display will update.

*Zero and Span points must be within 10% of factory setting.

PERFORMANCE SPECIFICATIONS

Accuracy RSS* (at constant temperature.) $\pm 1\%$ FS

*RSS of Non-Linearity, Non-Repeatability and Hysteresis.

Thermal Effects

Compensated Range °F(°C) +32 to +122°F (0 to 50)

Zero/Span Shift %FS/°F(°C) 0.03 (0.054)

Maximum Line Pressure 10 PSI

Warm-up Shift $\pm 0.2\%$ FS total

Position Effects

(Unit is factory calibrated at 0g effect in the vertical position)

Zero Offset (%FS/G) 0.2%

RETURNING PRODUCTS FOR REPAIR

Please contact a Setra application engineer (800-257-3872, 978-263-1400) before returning unit for repair to review information relative to your application. Many times only minor field adjustments may be necessary. When returning a product to Setra, the material should be carefully packaged and shipped prepaid to:

Setra Systems, Inc.

159 Swanson Road

Boxborough, MA

01719-1304

Attn: Repair Department

To download return form, please visit www.setra.com/tra/repairs/cal_rep

To assure prompt handling, please supply the following information and include it inside the package or returned material:

1. Name and phone number of person to contact.
2. Shipping and billing instructions.
3. Full description of the malfunction.
4. Identify any hazardous material used with product.

Allow approximately 3 weeks after receipt at Setra for the repair and return of the unit.

Non-warranty repairs will not be made without customer approval and a purchase order to cover repair charges.

Calibration Services

Setra maintains a complete calibration facility that is traceable to the National Institute of Standards & Technology (NIST). If you would like to recalibrate or recertify your Setra pressure transducers or transmitters, please call our Repair Department at 800-257-3872 (978-263-1400) for scheduling.

WARRANTY AND LIMITATION OF LIABILITY

SETRA warrants its Model 260 Transducer products to the original consumer purchaser against defects for a period of one year from the date of sale by SETRA, as shown in its shipping documents.

Without charge, SETRA will repair or replace products found to have manufacturing defects within the warranty period.

The serial number or date code must not have been removed, defaced or otherwise changed. SETRA must be notified in advance of any returns; any products returned to SETRA must be transportation prepaid.

The foregoing warranty is in lieu of all warranties, express, implied or statutory, including but not limited to, any implied warranty of merchantability for a particular purpose.

SETRA's liability for breach of warranty is limited to repair or replacement, or if the goods cannot be repaired or replaced, to a refund of the purchase price. SETRA's liability for all other breaches is limited to a refund of the purchase price. In no instance shall SETRA be liable for incidental or consequential damages arising from a breach of warranty, or from the use or installation of its products.

No representative or person is authorized to give any warranty other than as set out above or to assume for SETRA any other liability in connection with the sale of its products.

For all CE technical questions, contact Setra Systems, USA. EU customers may contact our EU representative Hengstler GmbH, Umlandstr. 49, 78554 Aldingen, Germany (Tel: +49-7424-890, Fax: +49-7424-89500).

SS260 Rev.B 07/26/2011

Toll Free: 1-800-257-3872 **Fax:** 1-978-264-0292

Web Site: www.setra.com