

SERVOPRO Plasma

OPERATOR MANUAL

Part Number: 02001001A
Revision: 10
Language: UK English



CONTENTS

Section		Page
1	DESCRIPTION AND DEFINITIONS.....	5
1.1	Scope of this manual	5
1.2	Safety information.....	5
1.3	Description.....	6
1.3.1	Ordering options	6
1.3.2	02001 Analyzer layout	7
2	SPECIFICATION	9
2.1	General	9
2.2	Environmental limits.....	9
2.3	Electrical data	10
2.4	Sample Gases	10
2.5	Calibration gas.....	11
2.6	Performance	11
3	UNPACK THE ANALYZER.....	12
4	INSTALLATION AND SET-UP	13
4.1	Mechanical installation rack mounting.....	15
4.2	Electrical Installation	16
4.2.1	Electrical Safety	16
4.2.2	Connect the electrical supply.....	17
4.2.3	Milliamp output connections	18
4.2.4	Alarm, remote range and status relay connections (general)	19
4.2.5	Alarm output option	20
4.2.6	RS232 connection (option)	22
4.3	Connect the sample/ auto calibration (optional) gas pipeline(s)	25
5	GENERAL OPERATION	28
5.1	Power on and start up.....	28
5.2	Routine and operational verification	29
5.3	Configuration	30
5.3.1	Auto ranging	30
5.3.2	Sample flow	30
5.3.3	Analogue output mode	30
5.3.4	mA failure mode	31
5.4	Calibration.....	32
5.5	Diagnosis	35
5.5.1	Error and Alarm Historic	37
5.5.2	Serial number	38
5.6	Run	39
5.7	Special consideration about the 0 - 1 ppm range.....	40
5.8	Hidden Menu	41
5.8.1	Starting Count.....	41
5.8.2	Temperature Coefficient	42
5.8.3	Time and date setting	44
5.8.4	System Gain	46
5.8.5	PID values	47
5.8.6	Lock range	48

5.8.7	Averaging Number.....	49
5.8.8	Calibration done parameters	50
6	ROUTINE MAINTENANCE (STANDARD ANALYZER).....	51
6.1	Cleaning the analyzer.....	51
6.2	Inspecting/replacing the fuse (when necessary)	52
7	SPARES	53
8	STORAGE AND DISPOSAL.....	53
8.1	Storage	53
8.2	Disposal	53
8.2.1	Product disposal in accordance with the Waste Electrical and Electronic Equipment (WEEE) Directive	54
9	COMPLIANCE AND STANDARDS INFORMATION.....	55
10	CONTACT INFORMATION	55
APPENDIX 1: AUTOMATIC CALIBRATION OPTION		56
1	AUTOMATIC CALIBRATION OPTION.....	57
1.1	Gas Circuit Description.....	57
1.2	System Operation	58
1.3	Entering Zero and span gas values.....	58
1.4	Manual Calibration.....	58
1.5	Automatic Calibration Mode.....	61
APPENDIX 2: TRACE NITROGEN IN HELIUM VERSION.....		65
2	TRACE NITROGEN IN HELIUM VERSION	66
2.1	User Manual	66
2.2	Flow Control System.....	66
2.3	Leaks	66
2.4	Working with Helium	66
APPENDIX 3: DUAL BACKGROUND ANALYZERS.....		68
3	DUAL BACKGROUND ANALYZERS.....	69
3.1	NOTE TO THE READER.....	69
3.2	User Manual	69
3.3	Flow control system	69
3.4	Leaks	69
3.5	Configuration and operation	70
3.5.1	Introduction	70
3.5.2	HIDDEN menu access.....	70
3.5.3	Operating consideration	72
APPENDIX 4: INTERFACE FOR EXTERNAL VALVE BOX		74
4	INTERFACE FOR EXTERNAL VALVE BOX (VB)	75
4.1	Description	75
4.2	Main Menu	75
4.3	Calibration Menu.....	75
4.4	Status Data and Commands through the RS-232 Port	76
4.5	Controlling the valves of Valve Box from the analyzer	80

Figure 1 - FRONT OF THE ANALYZER	7
Figure 2 - REAR OF THE ANALYZER.....	7
Figure 3 - INTERNAL SCHEMATIC.....	8
Figure 4 - DIMENSIONAL OUTLINE DRAWING	14
Figure 5 - INSTALL THE 02001 ANALYZER IN A PANEL	15
Figure 6 - REAR VIEW CUT OUT DIMENSIONS	15
Figure 7 - ANALOGUE OUTPUT INTERFACE CONNECTOR	18
Figure 8 - DIGITAL OUTPUT INTERFACE CONNECTOR.....	19
Figure 9 - CONFIGURATION MENU, PAGE 2	20
Figure 10 - ENTERING ALARM #1 SET POINT	20
Figure 11 - RS232 CONNECTION PIN DETAILS.....	23
Figure 12 - IDEAL INSTALLATION EXAMPLE	26
Figure 13 - POOR INSTALLATION EXAMPLE 1	26
Figure 14 - POOR INSTALLATION EXAMPLE 2.....	27
Figure 15 - POOR INSTALLATION EXAMPLE 3.....	27
Figure 16 - MAIN MENU.....	28
Figure 17 - CONFIGURATION MENU.....	30
Figure 18 - CONFIGURATION MENU - PAGE 2	31
Figure 19 - MAIN CALIBRATION.....	32
Figure 20 - DISPLAYED WHEN ENTERING ZERO VALUE	32
Figure 21- DISPLAYED WHEN ENTERING SPAN VALUE	33
Figure 22 - CALIBRATION SUB MENU.....	33
Figure 23 - DIAGNOSTIC MAIN MENU.....	35
Figure 24 - DIAGNOSTIC MAIN MENU.....	35
Figure 25 - DIAGNOSTIC MENU.....	36
Figure 26 - DIAGNOSTIC MENU.....	37
Figure 27 - SERIAL NUMBER MENU.....	38
Figure 28 - RUN MODE.....	39
Figure 29 - HIDDEN MENU, FIRST PAGE	41
Figure 30 - TEMPERATURE COEFFICIENT	42
Figure 31 - TEMPERATURE GAIN.....	43
Figure 32 -TIME AND DATE SETTING (1)	44
Figure 33 - TIME AND DATE SETTING (2)	44
Figure 34 - TIME AND DATE SETTING (3)	45
Figure 35 - TIME AND DATE SETTING (4)	45
Figure 36 - SYSTEM GAIN.....	46
Figure 37 - GAS FLOW PID VALUES.....	47
Figure 38 - CHANGING A PID VALUE	47
Figure 39 - LOCK RANGE.....	48
Figure 40 - AVERAGING NUMBER.....	49
Figure 41 - CALIBRATION DONE PARAMETERS.....	50
Figure 42 - CALIBRATION MODE SELECTION MENU	58
Figure 43: CALIBRATION FACTOR CALCULATION MENU	59
Figure 44 - CALIBRATION FACTOR CALCULATION MENU	60
Figure 45 - TRANSFER DELAY	61

Figure 46 - FIRST PAGE OF THE HIDDEN MENU61
Figure 47 - AUTOMATIC CALIBRATION TIMERS62
Figure 48 - ANALOG OUTPUT HOLD TO TRACK TRANSFER DELAY 62
Figure 49 - SERVOPRO PLASMA WITH AUTOMATIC CALIBRATION64
Figure 50 - OPERATING PARAMETERS MENU70
Figure 51 - BACKGROUND GAS SELECTION MENU71
Figure 52 - TEMPERATURE COEFFICIENT MENU71

1 DESCRIPTION AND DEFINITIONS

1.1 Scope of this manual

This manual provides installation, operation and routine maintenance instructions for the SERVOPRO Plasma Trace N₂ Analyzer, abbreviated to "analyzer" in the remainder of this manual.

1.2 Safety information

Read this manual and ensure that you fully understand its content before you attempt to install, use or maintain the analyzer. Important safety information is highlighted in this manual as WARNINGS and CAUTIONS, which are used as follows:

	<p style="text-align: center;">WARNING</p> <p>Warnings highlight specific hazards which, if not taken into account, may result in personal injury or death.</p>
---	--

Where the above symbol is marked on the equipment the manual must be consulted in order to find out the nature of the potential hazards and any actions which have to be taken to avoid them.

<p style="text-align: center;">CAUTION</p> <p>Cautions highlight hazards which, if not taken into account, can result in damage to the analyzer or to other equipment or property.</p>
--

This manual also incorporates 'Be aware of' information, which is used as follows:

-  This highlights information which it is useful for you to be aware of (for example, specific operating conditions, and so on).

1.3 Description

	<p style="text-align: center;">WARNING</p> <p>This analyzer is not a medical device as defined in the medical devices directive 93/42/EEC and is not intended to be used on human beings for the diagnosis, prevention, monitoring, treatment or alleviation of disease, injury or replacement or modification of the anatomy.</p>
---	---

	<p style="text-align: center;">WARNING</p> <p>The analyzer must not be used as personal protective equipment.</p>
---	--

The analyzer is designed to meet the needs of the control and product quality applications of industrial gas producers and users, who require fast, accurate and reliable gas analysis.

Gas sample measurements are shown on the analyzer display, and can also be output to a serial device connected to the analyzer, or as milliAmp (mA) output. The SERVOPRO PLASMA Trace N₂ Analyzer can support one gas measurement using a plasma transducer measuring trace level nitrogen in argon or helium.

1.3.1 Ordering options

For the latest ordering options please contact your local Servomex agent or visit www.servomex.com

1.3.2 02001 Analyzer layout

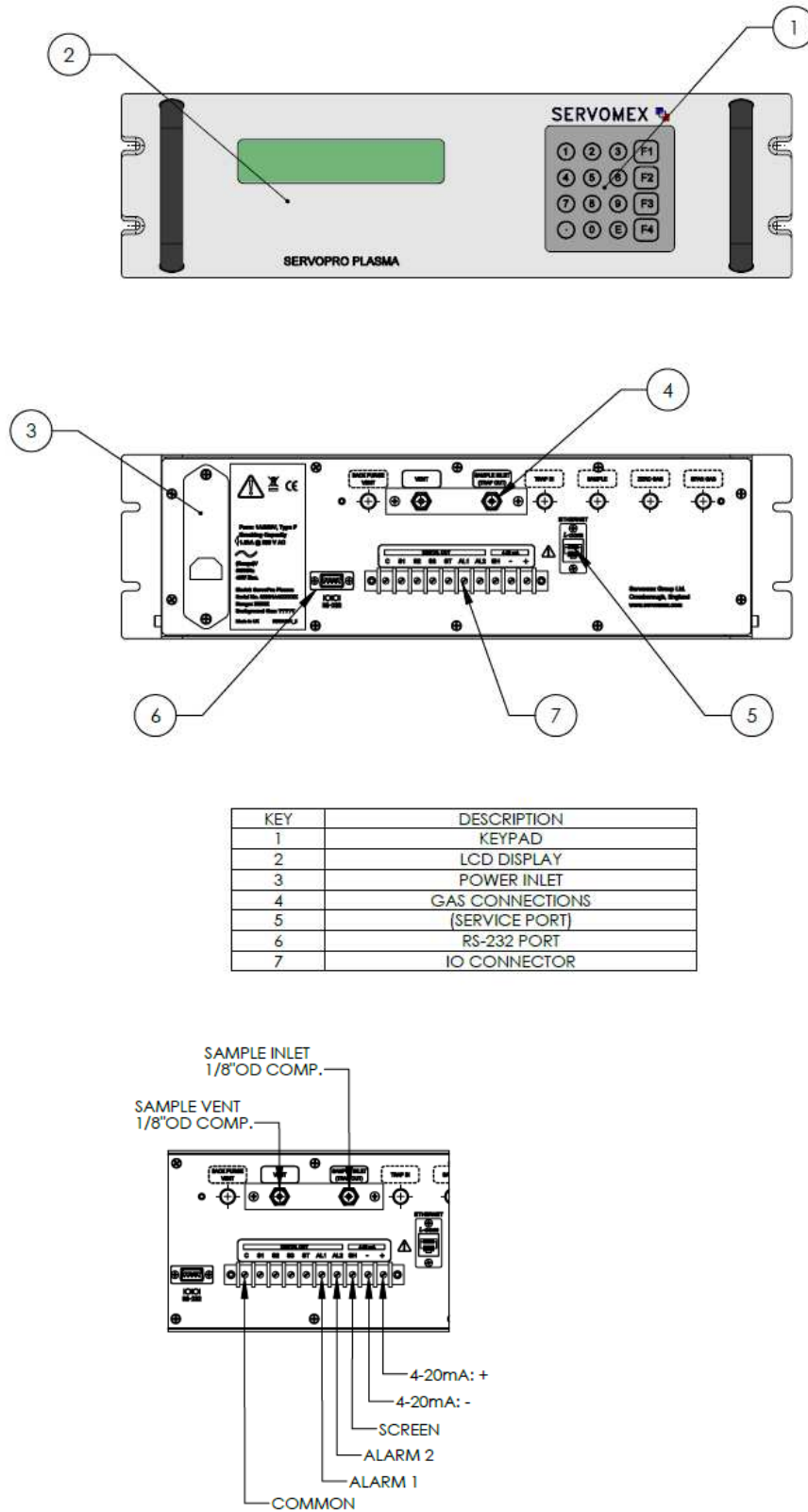

Figure 1 - FRONT OF THE ANALYZER
Figure 2 - REAR OF THE ANALYZER

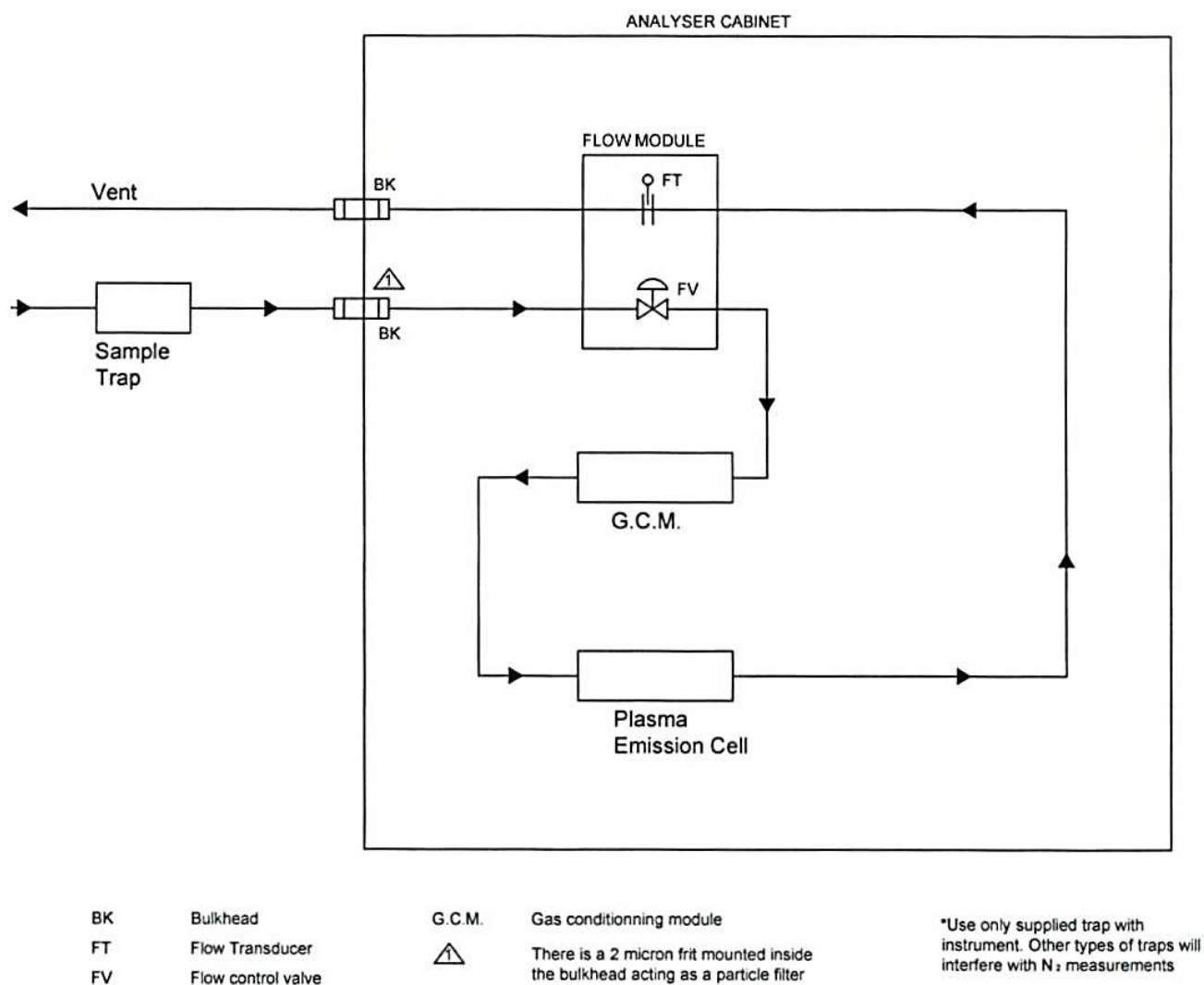



Figure 3 - INTERNAL SCHEMATIC

2 SPECIFICATION

	WARNING The protection, accuracy, operation and condition of the equipment may be impaired if the analyzer is not installed in accordance with the requirements of this and subsequent sections of the manual.
	WARNING Not suitable for flammable samples. Never pressurise the analyzer. Always remove vent plug before connecting the sample inlet.

2.1 General

Dimensions	(Height x Width x Depth): 133 mm x 483 mm x 457 mm (5.25 ins x 19 ins x 18 ins)
Mass	15 kg

2.2 Environmental limits

Equipment is suitable for indoor use only

Ambient temperature range

Operation: 5 to 40°C

Storage: -20 to 60°C

Operating ambient pressure range: 101.3 kPa ± 10% (1.013 bar ± 10%)

Operating ambient humidity range: 0 to 95% RH, non-condensing

Operating altitude range: to 2000 † metres

Ingress protection: IP20

† Above sea level.

2.3 Electrical data

Electrical supply

Voltage:	100 - 120 Vac / 230 - 240 Vac, 50 to 60 Hz (± 10% maximum fluctuation) ⁽¹⁾⁽²⁾
Fuse rating / type:	Two fuses 1 amp / 250 V, Type "F", Breaking capacity 1.5kA @ 250 V AC miniature fuses 5 x 20 mm
Maximum power consumption:	45W
Interface signal relay ratings:	30 Vrms, 42.4 V peak or 60 Vdc/ 1A
mA output (active)	
Maximum load resistance:	600 Ω at 20 mA DC
Isolation voltage (to earth):	750 VDC or AC
Normal sample measurement:	4mA to 20 mA
Fault condition:	4 mA or 20 mA (can be set high or low)

- (1) The analyzer is supplied configured for operation with one of these voltage ranges. You must specify the voltage range when you order the analyzer.
- (2) The analyser reading may fluctuate by up to 6% if the supply voltage drops below 95Vac

2.4 Sample Gases



The sample gases must be, clean, non-corrosive, free from oil and condensates and compatible with the materials listed in Appendix 1

Flow rate:	25 to 150 ml min ⁻¹
Pressure:	27.6 to 55.2 kPa gauge (max) (5 to 10 Psig(max))
Dew point:	5 °C below ambient temperature (minimum)
Temperature:	5 to 40 °C
Particulate size:	< 2 μm (2 micron)

CAUTION

To retain the CE mark, do not operate above 70kPa (10psig)

2.5 Calibration gas



The calibration gases must be clean, non-corrosive, free from oil and condensates and compatible with the materials listed in Appendix 1

High calibration set point At least 90% FSD N₂ in Ar or He
 Low calibration set point 6N Grade Ar or He

2.6 Performance

Detector type: Plasma Emission Detector (PED). Material: Quartz, single element, vacuum tight to 69 kPa (10 Psig)

Ranges: Choice of one of the following -

- 0-1/0-10/0-100 ppm
- 0-10/0-50/0-100 ppm
- 0-10/0-50/0-250 ppm ⁽³⁾
- 0-10/0-100/0-1000ppm ⁽³⁾

Display Resolution:

0-1 ppm range: 10 ppb
 0-10 ppm range: 0.1 ppm
 0-50ppm range: 0.5 ppm
 0-100, 250, 500, 1000 ppm ranges: 1ppm

Auto-zero, auto-span calibration system: (optional)

Serial port: RS-232 (optional)

Digital output: 3 range indication, 1 system status

	0-1/ 0-10 /0-100 ppm	0-10 /0-50/ 0-100 ppm	0-10/ 0-50/ 0-250 ppm ⁽³⁾	0-10/ 0-100/ 0-1000 ppm ⁽³⁾
Accuracy ⁽¹⁾	≤ ±1% Range ⁽²⁾	≤ ±1% Range ⁽²⁾	≤ ± 5% Range ⁽²⁾	≤ ± 5% Range ⁽²⁾
Drift over 24 hours	≤ ±1% Range ⁽²⁾	≤ ±1% Range ⁽²⁾	≤ ± 1% Range ⁽²⁾	≤ ±1% Range ⁽²⁾
Noise ⁽¹⁾	≤ ± 1% Range ⁽²⁾	≤ ± 1% Range ⁽²⁾	≤ ± 5% Range ⁽²⁾	≤ ± 5% Range ⁽²⁾
Zero temp coefficient	≤ ± 0.25 ppm/10°C	≤ ± 0.25 ppm/10°C	≤ ± 0.63 ppm /10°C	≤ ± 2.5 ppm/10 °C

(1) The accuracy may be decreased by an additional 6% maximum range at some frequencies under the influence of radiated RF fields specified for low voltage supply which supplies buildings for domestic purposes.

(2) Calibrated Range

(3) N₂ in Ar only

3 UNPACK THE ANALYZER



WARNING

The analyzer is heavy (see Section 2.1). Care must be taken when handling. It is recommended that they are lifted with hands positioned on either side on the base of the chassis.

Remove the analyzer and any other equipment from its packaging.

Remove any protective caps from the sample gas inlets and outlets on the rear of the analyzer (see Figure 1 and Figure 2)

 It is advisable that the protective caps are kept on prior to fitting.

Inspect the analyzer and the other items supplied, and check that they are not damaged. If any item is damaged, immediately contact Servomex or your local Servomex agent.

Check that you have received all of the items that you ordered. If any item is missing, immediately contact Servomex or your local Servomex agent.

If you do not intend to use the analyzer immediately:

- Refit any protective caps.
- Place the analyzer and any other equipment supplied back in its protective packaging.
- Store the analyzer as described in Section 8.1.

 Retain the shipping documentation and packaging for future use (for example, return of the analyzer to Servomex for servicing or repair).

4 INSTALLATION AND SET-UP



WARNING

The analyzer must be installed by a suitably skilled and competent person. The following procedure must be followed to prevent a hazard.



WARNING

The analyzer is only suitable for installation in unclassified areas.

CAUTION

Do not install the analyzer in a frame/rack or on a bench which is subject to high levels of vibration or sudden jolts. If you do, sample measurements may not be accurate, or the analyzer may be damaged.

CAUTION

Do not install analyzer in an area where a strong electromagnetic field is present. Never use radio transmitters near the analyzer.

CAUTION

To avoid damage to analyzer, always leave the protection caps on gas connections until clean gas is ready to flow in the analyzer.

CAUTION

The vent connection of the analyzer must be at atmospheric pressure all the time. Pressurizing the vent side of analyzer could cause the quartz cell to crack and also damage the flow module.

CAUTION

Do not expose the analyzer to high level of direct sunlight.

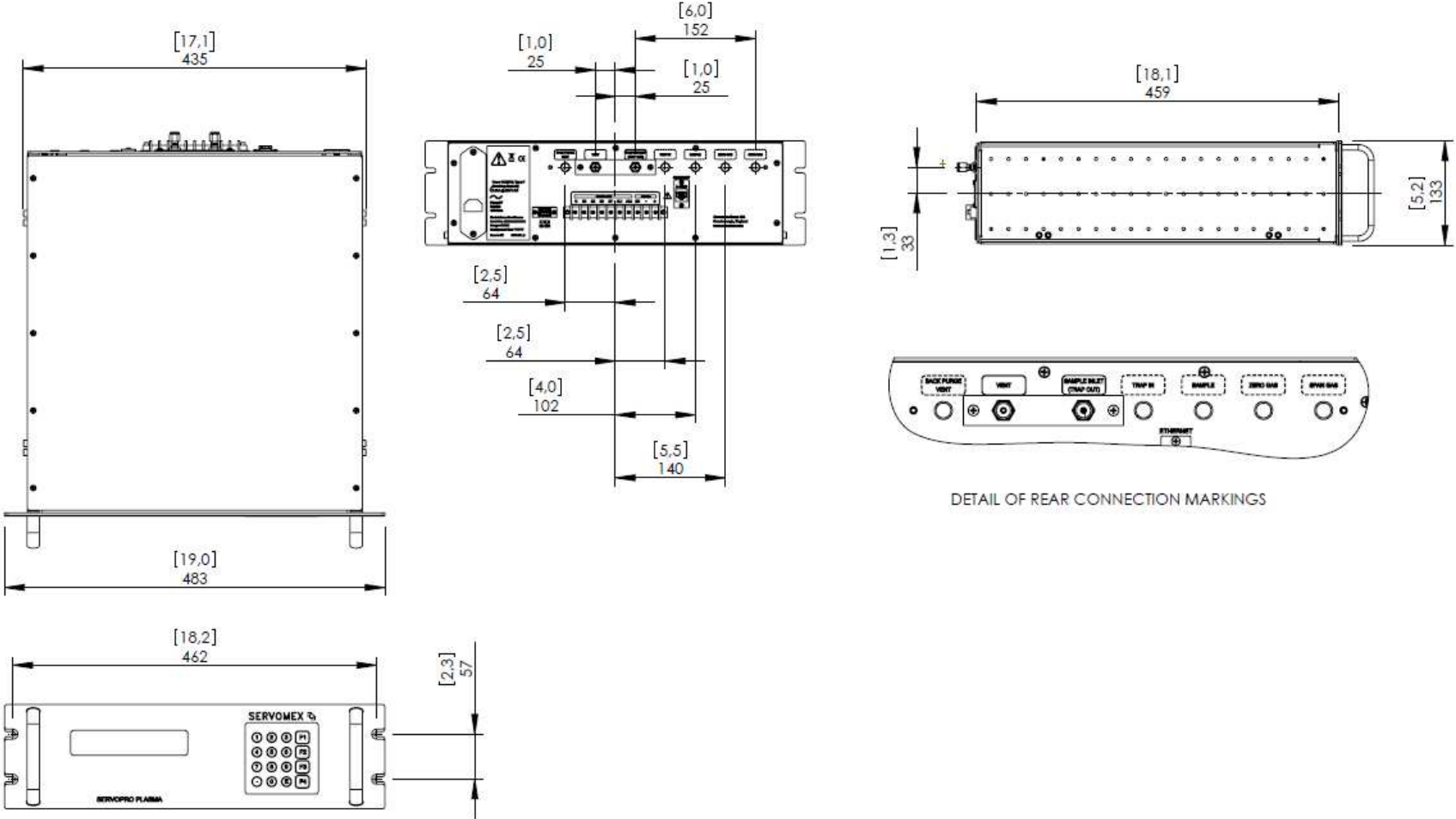

Figure 4 - DIMENSIONAL OUTLINE DRAWING

4.1 Mechanical installation rack mounting

CAUTION

The analyzer must not be supported by the front panel alone. You must provide an additional support under the base of the analyzer towards the rear of the enclosure as shown in Figure 5 - INSTALL THE 02001 ANALYZER IN A PANEL.

If you do not, the analyzer may be damaged, or may fall and damage other equipment.

Refer to Figure 5 and Figure 6

Prepare a cut-out in a suitable panel capable of supporting 15kg.

Prepare a suitable base support and secure it in your frame or cabinet capable of supporting 15kg.

Fit the analyzer in the panel and use nuts and bolts through the fixing holes in the panel and the mounting brackets to secure the analyzer in place.

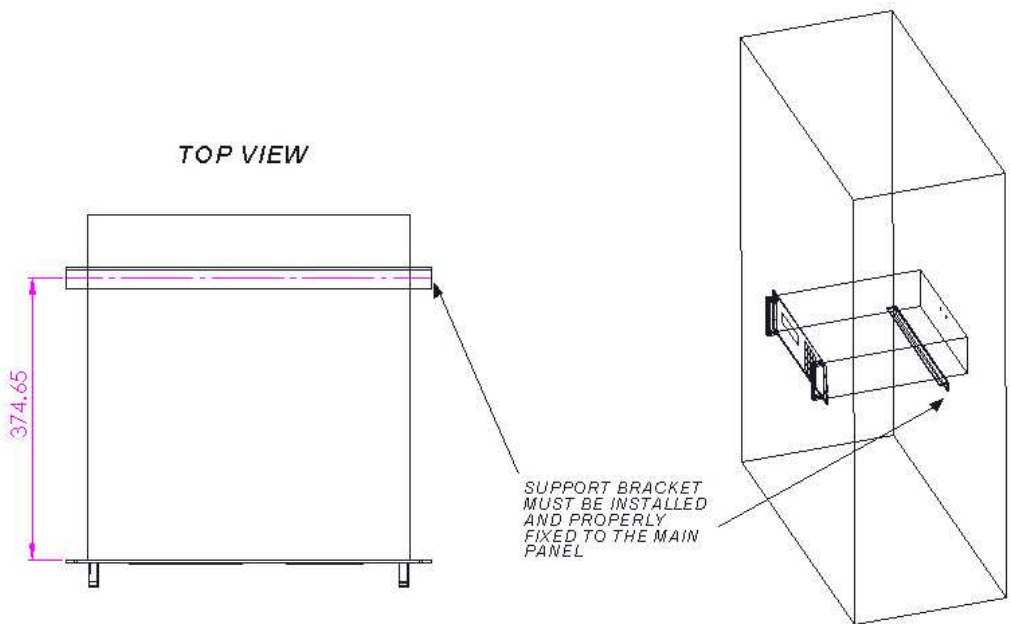

Figure 5 - INSTALL THE 02001 ANALYZER IN A PANEL

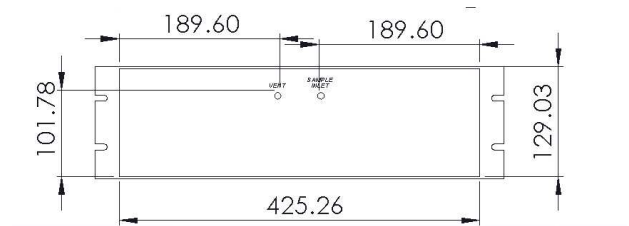





Figure 6 - REAR VIEW CUT OUT DIMENSIONS

4.2 Electrical Installation

4.2.1 Electrical Safety

	<p style="text-align: center;">WARNING</p> <p>Ensure that the electrical installation of the analyzer conforms with all applicable local and national electrical safety requirements.</p>
---	--

	<p style="text-align: center;">WARNING</p> <p>Obey the safety instructions given below when you install the analyzer; if you do not, the analyzer warranty may be invalidated, the analyzer may not operate correctly, or it may be damaged.</p>
---	---

-  The electrical supply coupler or plug must be easily accessible for disconnection from the electrical supply.

-  Ensure that your electrical supply can provide the necessary maximum power consumption: refer to Section 10

-  All signal and electrical supply cables must be rated for temperatures of 70 °C or higher.

-  Ensure that the cables that you connect to the analyzer are routed so that they do not present a trip hazard.

-  When you carry out insulation testing, disconnect all cables from the analyzer.

-  Ensure the analyzer is provided with a sound earth connection via the electrical supply plug (Figure 2 Item 3).



4.2.2 Connect the electrical supply



WARNING

Only use the power supply cord provided with the unit.

CAUTION

Ensure that the analyzer is suitable for use with your electrical supply voltage and frequency. If the analyzer is not suitable, the analyzer may not operate correctly, or it may be damaged when you operate it.



To comply with the relevant safety requirements the cables carrying mains power and connected to the analyzer shall be approved to:

For EU: IEC 60227 or IEC 60245 and be designated H05VV-F.

For North America: UL817 or CSA C22.2 No. 21 and be designated SJT.



Ensure that the cables that you connect to the analyzer are routed so that they do not present a trip hazard.

The analyzer is supplied with an electrical supply cable, configured for your electrical supply. Connect the electrical supply to the analyzer as follows:

Fit the IEC plug on the electrical supply cable provided to the electrical supply socket on the rear of the analyzer (Figure 2 item 3).

Check the earth (ground) continuity between your electrical supply outlet earth (ground) and the SH (ground) terminal on the rear of the analyzer (Figure 2 item 7) or exposed metal work.

Connect the electrical supply cable to your electrical supply outlet.

4.2.3 Milliamp output connections

	<p style="text-align: center;">WARNING</p> <p>The milliamp outputs are separated from the analyzer mains circuits by reinforced insulation. The terminals must only be connected to circuits that are themselves separated from mains voltages by an isolation method that provides at least this level of protection.</p>
---	---

<p style="text-align: center;">CAUTION</p> <p>To comply with EMC requirements, screened cables must be used to connect the analogue outputs and the screen of the mA output shall be connected to the analyzer enclosure. The remote end of the screen shall be open circuit.</p>

Connect the positive and negative wires in your cable to the screw terminals on the rear panel refer to Figure 7. Section 2.3 provides information on the rating of cable.

The screen should be connected to the SH point on the rear of the analyzer.

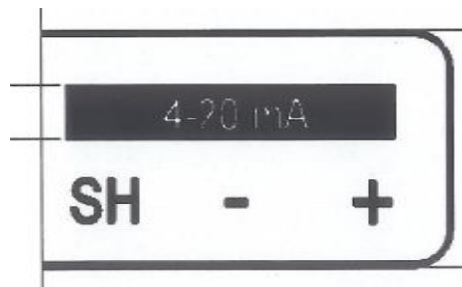



Figure 7 - ANALOGUE OUTPUT INTERFACE CONNECTOR

4.2.4 Alarm, remote range and status relay connections (general)

	<p>WARNING</p> <p>The alarm remote range and status relay connections are separated from the analyzer mains circuit by reinforced insulation. The terminals must only be connected to circuits that are themselves separated from mains voltage by an isolation method that provides at least this level of protection.</p>
---	--

<p>CAUTION</p> <p>To comply with EMC requirements, screened cables must be used to connect the relay outputs and the screen of the relay outputs shall be connected to the analyzer enclosure. The remote end of the screen shall be open circuit.</p>

Connect the wires in your cable to the screw terminals on the 6 pin connector provided. Section 2.3 provides information on the rating of cable.

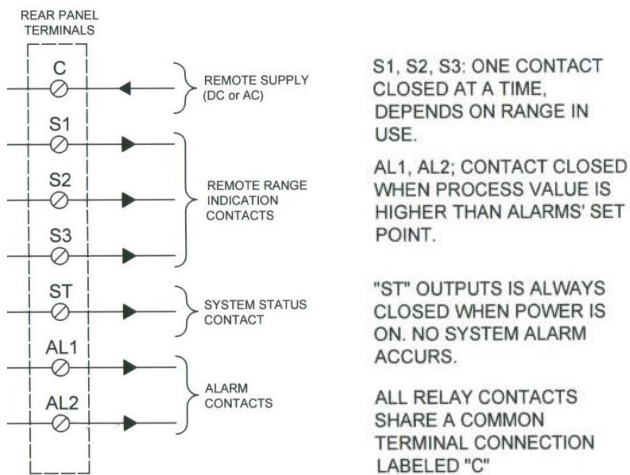

Figure 8 - DIGITAL OUTPUT INTERFACE CONNECTOR

Circuits connected to terminals S1, S2, S3, ST, AL1 and AL2 shall only be powered by supply connected to terminal C.

4.2.5 Alarm output option

With this option, two digital dry contact outputs are available for process alarms. These contacts are always closed for fail safe purposes. They are connected to a terminal strip labelled "AL1" for alarm #1 and "AL2" for alarm #2. One side of each relay is connected to the "C" terminal, on the rear panel terminal strip. They share the same fuse used by other digital outputs. The total current of all loads connected to digital output i.e. status, range in use; and alarms must not exceed: 30 Vrms, 42.4 V peak or 60 Vdc, 1 Amp maximum. The alarms output contacts are protected with snubber circuits mounted on the digital output board inside the analyzer.

When the ppm value of the sample gas exceeds the set point of alarm #1 or alarm #2 their respective contact will open.

To enter the set point value for alarms you should go in the CONFIGURATION MENU, at page 2 (to access page 2, press **F3** labelled NEXT on page 1).

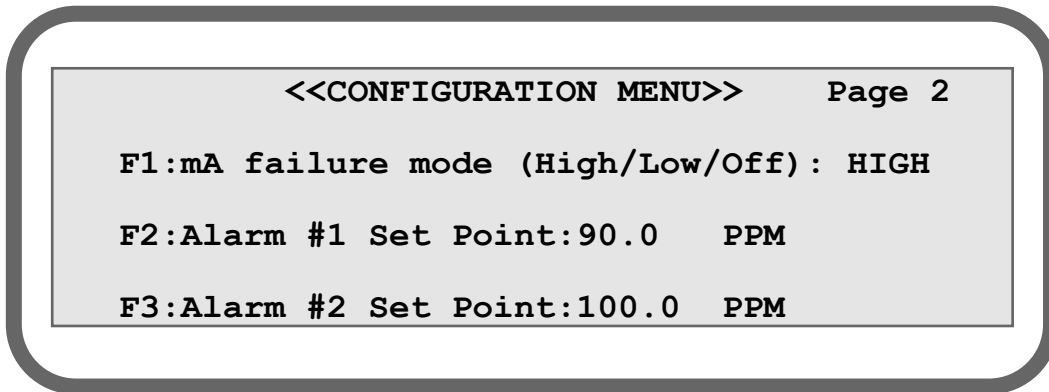

Figure 9 - CONFIGURATION MENU, PAGE 2

Pressing **F2** will bring up the line for entering the alarm set point for alarm #1.

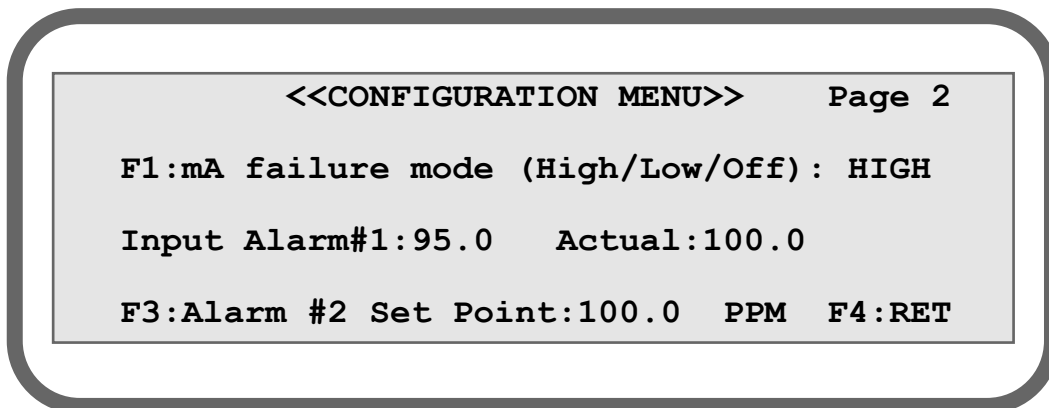

Figure 10 - ENTERING ALARM #1 SET POINT

Enter your value in ppm with the numerical keys and confirm with the "E" key for ENTER. Once the ENTER key is pressed, the value will be activated immediately and this value will be

displayed under ACTUAL. To exit the alarm #1 input function, press F4. This will bring up the original page 2 of CONFIGURATION MENU

To enter the set point for alarm #2, follow the same procedure as above, but press **F3**, this will bring up the following display.

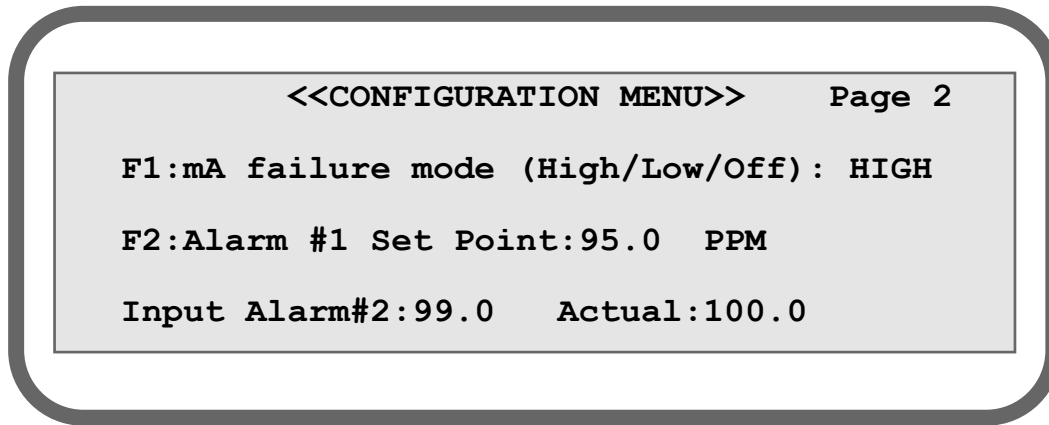

FIGURE 11: ENTERING ALARM #2 SET POINT

When you have finished entering your value for alarm #2, pressing **F1** brings up the original page 2 of the CONFIGURATION MENU (fig. 1). Pressing **F4** brings the first page of the CONFIGURATION MENU and pressing F4 again brings back to MAIN MENU.

The values you enter must be in ppm. You may enter any value from 0 to 100 ppm, for any alarm. Alarm #1 may have a set point higher or lower than alarm #2 and vice versa.

The digital contact output will open when the ppm value is equal or higher than the set point value. The contact will close when the actual ppm value will go under the set point minus 0.1 ppm. This hysteresis will avoid oscillation.

4.2.6 RS232 connection (option)

	<p style="text-align: center;">WARNING</p> <p>The RS232 communications terminals are separated from the analyzer main circuit by reinforced insulation. The terminals must only be connected to circuits that are themselves separated from mains voltages by an isolation method that provides at least this level of protection.</p>
---	---

	<p style="text-align: center;">WARNING</p> <p>Ensure that the electrical installation of any equipment connected to the analyzer conforms to all applicable local and national electrical safety requirements.</p>
---	---

<p>CAUTION</p> <p>To comply with EMC requirements, screened cables must be used to connect the RS232.</p>

With this option installed, this analyzer retransmits the operating parameters and process values to a remote computer through a serial link. The computer is connected to the analyzer by the mean of a DB-9 RS-232C (Null-modem) cable. The computer must have appropriate software to read the data transmitted by the analyzer.

The RS-232 port on the analyzer is driven by an opto-isolator/convertor.

All precautions are taken to give a reliable serial transmission, even if the opto isolator/convertor system provides a barrier against noise, transient and ground loop, it cannot support high voltage differences between two different floating systems. For this reason, the remote computer and the analyzer must be properly grounded (ground at same potential).

The standard RS-232C specifications stipulate a maximum distance of 15 metres between two systems. But, if you are using good communications cable (good shielding and low capacitance) longer distances may work successfully.

A RS-232C null modem DB-9 cable is supplied with the analyzer. This allows direct connection to a personal computer serial port.

The communication parameters of the analyzer are:

- Baud rate: 9600
- Parity bits: none
- Data bits: 8
- Stop bits: 1

The serial port on the rear of the analyzer (Figure 2 item 6) is an RS232 ± 5.5 V 9-way 'D' type connector.

Pin(s)	Use
1	Not used
2	Rx (to the analyzer)
3	Tx (from the analyzer)
4	Not used
5	0 V
6, 7, 8, 9	Not used

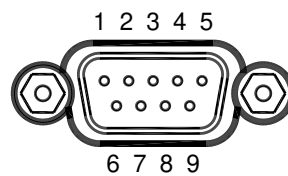

Figure 11 - RS232 CONNECTION PIN DETAILS

Standard RS-232 Interface - Transmission protocol

Note: see Appendix 4 for details of the transmission protocol for the Enhanced Interface for use with External Valve Box

The different parameters are transmitted in the following order for the standard interface:

ppm value sign, ppm value, **TAB**, flow, **TAB**, flow counts, **TAB**, cell counts **TAB**, status and range, **TAB**, checksum, **CR**.

Each parameter is formatted as followed:

- **PPM value sign:** 1 byte equal to "+" or "-" in ASCII, depending on the polarity of the ppm value;
- **PPM value:** 6 bytes in ASCII (3 digits before the dot and two after);
- **Flow:** 6 bytes in ASCII (3 digits before the dot and two after);
- **Flow counts:** 8 bytes in ASCII;
- **Cell counts:** 8 bytes in ASCII;
- **Status and range:** bitwise (logical on 8 bits);

bit 7: alarm 2	1 if alarm 2 is ON
bit 6: alarm 1	1 if alarm 1 is ON
bit 5: low flow	1 if there is a low flow error
bit 4: plasma status	1 if there is a plasma off error
bit 3: system status	1 if there is a low flow, plasma off, underscale or overscale error
bit 2, and 0: range in use	001 = range 1 (ex: 0-1 or 0-10 ppm) 010 = range 2 (ex: 0-10 or 0-50 ppm) 100 = range 3 (ex: 0-100 ppm)

Each value is separated by a TAB character. The end of one transmission (packet or frame) is indicated with a carriage return.

The checksum is the arithmetic sum of every transmitted byte (excluding TAB bytes). The checksum may be used to verify the data integrity.

Example : the ppm value is 40.1, the flow is 75.0 ml min⁻¹ (75 cc/min), the flow counts are 8388600, the cell counts are 190011, the range used is the first one (0-1 ppm), there are no alarm, but there is a low flow error. The data sent in ASCII is:

<u>Data</u>	<u>Check sum</u>
“+”, “NUL”, “4”, “0”, “.”, “1”, “0”, “TAB”,	286
“NUL”, “7”, “5”, “.”, “0”, “0”, “TAB”,	250
“NUL”, “8”, “3”, “8”, “8”, “6”, “0”, “0”, “TAB”,	369
“NUL”, “NUL”, “1”, “9”, “0”, “0”, “1”, “1”, “TAB”,	300
“)”, “TAB”,	<u>41</u>
	Total: 1246
1”, “2”, “4”, “6”, “CR”	

4.3 Connect the sample/ auto calibration (optional) gas pipeline(s)

	<p style="text-align: center;">WARNING</p> <p>Sample and calibration gases may be toxic or asphyxiant:</p> <ul style="list-style-type: none">• Ensure that the external connections are leak free at full operating pressure before you use sample or calibration gases.• Ensure that the sample outlet pipes are vented to an area where the gases will not be a hazard to people.• Ensure that the analyzer is used in a sufficiently well-ventilated environment, to prevent the build-up of toxic gases. <p>Ensure that the pipes that you connect to the analyzer are routed so that they do not present a hazard to people.</p>
---	--

	<p style="text-align: center;">WARNING</p> <p>The analyzer is not suitable for use with corrosive samples.</p>
--	--

	<p style="text-align: center;">WARNING</p> <p>Ensure the connectors used to connect to the analyzer are compatible with the connectors on the analyzer.</p>
---	---

<p>CAUTION</p> <p>The Vent connection of the analyzer must be at atmospheric pressure at all times. Pressurising the vent side of the analyzer could cause permanent damage to the quartz cell and flow module.</p>

Connect your sample/calibration gas inlet and outlet pipelines to the inlets and outlets on the rear of the analyzer (see Figure 2 - REAR OF THE ANALY). The sizes of the fittings are 1/8" compression fittings:

Refer to Section 2.4 and 2.5 for sample gas and calibration gas requirements. Locate your gas selection valves as close as possible to the analyzer.

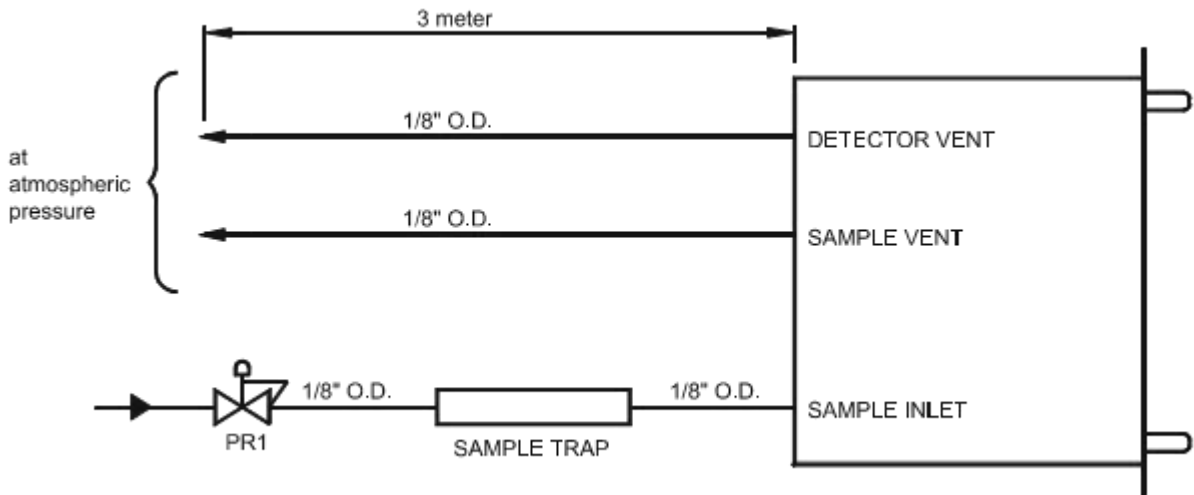

Figure 12 - IDEAL INSTALLATION EXAMPLE

PR1 is a miniature stainless steel high purity pressure regulator. The internal volume must be at it's absolutely minimum. Any unswept dead volume will cause noise and instability and, will cause poor recovery time. PR1 should be installed close to the sample point. PR1 should be installed only if there is large pressure excursion (over 69 kPa (10 PSIG)).

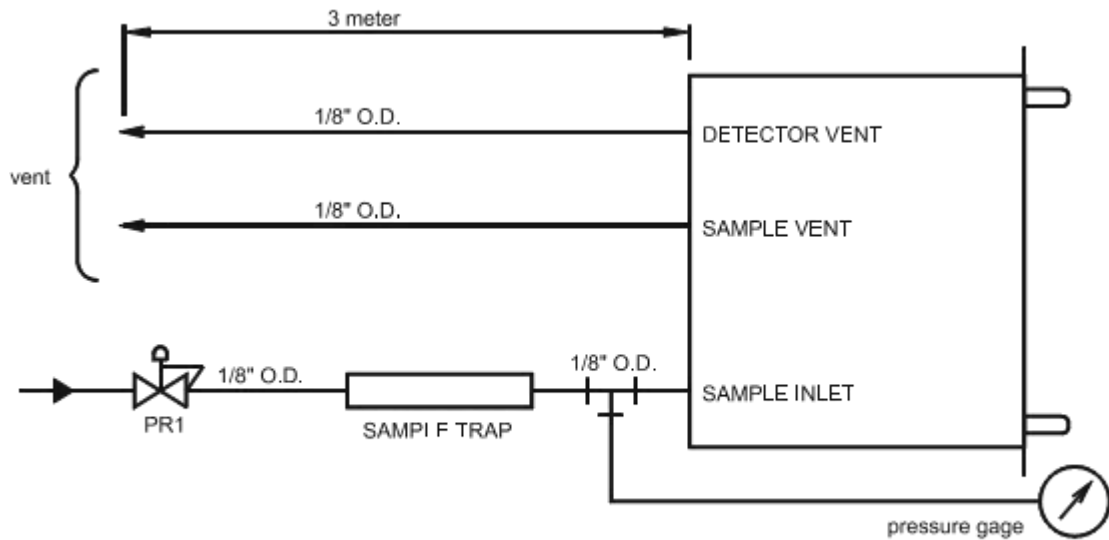

Figure 13 - POOR INSTALLATION EXAMPLE 1

Some users wish to monitor the inlet pressure. Connecting a pressure gauge at the inlet will result in big unswept volume. This will cause poor response time, drift and noise.

Problems caused: long response time, will eventually read below the scale because of error of calibration.

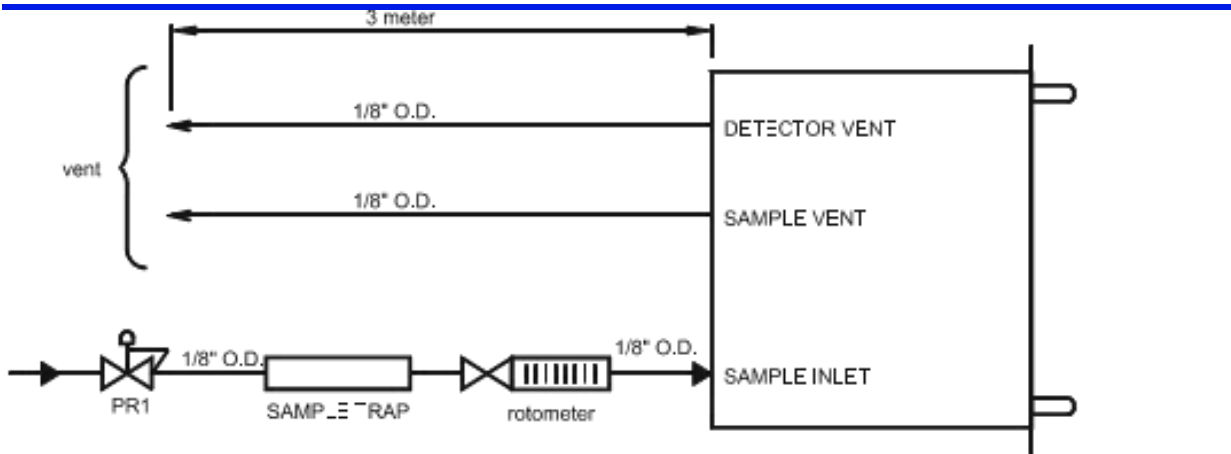

Figure 14 - POOR INSTALLATION EXAMPLE 2

Some users wish to monitor the inlet flow with a falling ball rotameter. Those rotameters (or flowmeters) are calibrated at atmospheric pressure. The flow indicated will be wrong, it must be compensated for the line pressure. Furthermore, these types of rotameters are absolutely not leak tight. Air will diffuse into the system, there will also be some permeation through the material used to build it. There is also a risk that someone tries to control the flow with the valve mounted on this rotameter (if any). This will be in conflict with the analyzer internal flow control system.

Problems caused: line pollution, flow instability, reading will be noisy, reading will definitely drift.

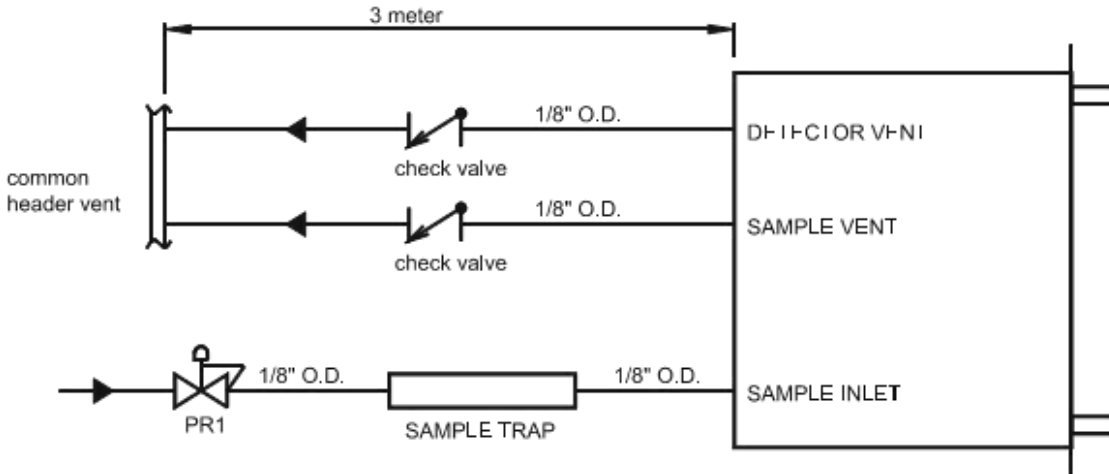

Figure 15 - POOR INSTALLATION EXAMPLE 3

Some users wish to avoid back flow from a vent header into the analyzer vent. Doing so will cause sample flow and cell pressure variation. The cell pressure will follow header pressure variation. Check valve cracking pressure is not constant. The plasma cell must work at atmospheric pressure with no backdraft. Problems caused: noisy signal, risk of cracking the cell on the event of check valve failure.

5 GENERAL OPERATION

5.1 Power on and start up

CAUTION

**Sample and calibration gases must be as specified in Sections 2.4 and 2.5 .
If the pressure/flow rates are outside the ranges specified in Section 2.1, you
must regulate the gases externally, before they enter the analyzer.**

Before putting the power on, be sure that your gas lines are properly purged with good quality argon. In this way, the analyzer will be ready to use much faster. Also, and more importantly, you will not send higher level of impurities in the plasma.

To power on the analyzer press the switch situated on the rear of the analyzer reference figure 2 item 3

At power on, the analyzer displays the **MAIN MENU**.

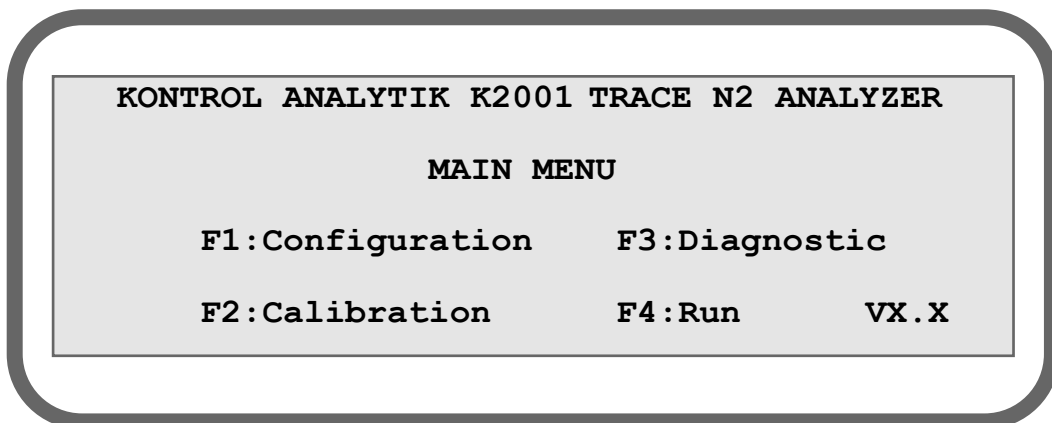

Figure 16 - MAIN MENU

The **MAIN MENU** is shown in Figure 16 - MAIN MENU. The following sections give a complete description of each menu and sub-menu.

On power up the flow control valve (ref. figure 3) is cold and it may take up to two minutes for the gas to flow through. Once the valve is warm the flow will stabilize.

If the flow is set to 0 cc for a while the valve will cool down again and require further time to stabilize when flow is re-initiated.

CAUTION

Never leave the flow set point higher than zero cc if gas is not available, as there is a risk of damaging the valve, and flow module replacement will be necessary. For this reason make sure that gas is available before powering up the analyzer.

Purge the analyzer for a minimum of 10 hours with good quality argon.

When the system is powered up, the flow set point has a default value of 75 cc; it normally does not require further setting, except for faster purging. In this case, increase the flow to 190 cc to purge the analyzer for a minimum of 2 hours.

After the purge time is elapsed, you may adjust down the by-pass rotameter to an acceptable flow, depending on the speed of response required and the distance between the analyzer and the source of gas to be analyzed. The analyzer flow set point may be returned to 75 cc/m.

You are now ready to calibrate the analyzer, refer to section 0.

Once the calibration is done, the analyzer is now functional; it will take a few days for the analyzer to stabilize itself. For this reason, it may be necessary to recalibrate.

5.2 Routine and operational verification

From time to time, it is a good idea to go in to the "**DIAGNOSTIC MENU**", check cell counts with a reference gas and record this value for comparison with a later value. This gives an indication of the degree of cell offset.

Also, check the flow count stability. Too much variation is an indication of line clogging.

The frequency of calibration is normally once a week.

5.3 Configuration

Pressing **F1** from the **MAIN MENU** will bring you to the **CONFIGURATION MENU**.

The **CONFIGURATION MENU** prompts you to enter three different parameters:

5.3.1 Auto ranging

"Auto ranging". Choosing "**F1**" "yes" allows the analyzer to "switch" automatically between the three possible ranges. "**F1**" "toggles" the selection between "yes" and "no".

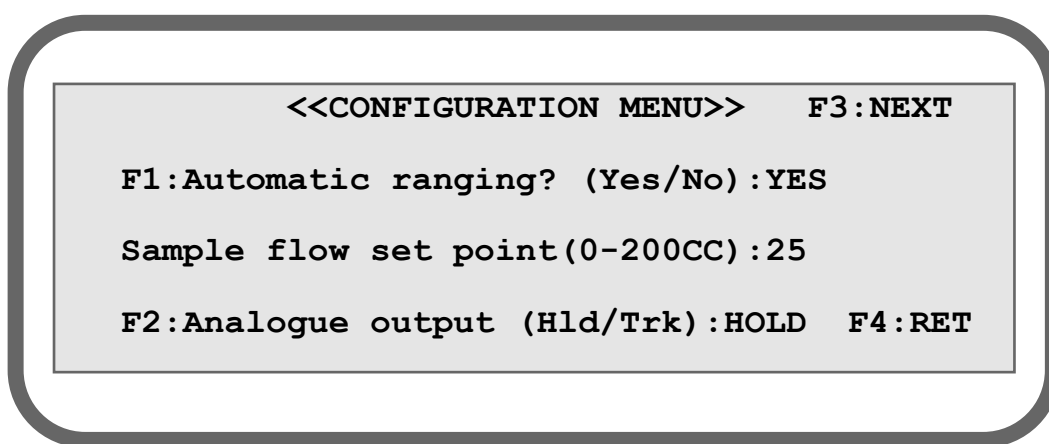

Figure 17 - CONFIGURATION MENU

5.3.2 Sample flow

Enter your desired sample flow value simply by using the number keys and confirming your value with the "**E**" key for enter. The allowed numeric value for the flow is any integer number between 0 and 200. The flow unit is cc/m.

The new input value becomes immediately active and the flow valve will react accordingly.

5.3.3 Analogue output mode

By pressing the "**F2**" key, the analogue 4 - 20 mA output will be in either "track" or "hold" mode.

Hold mode: "hold" will maintain analogue output at last "on run" gas value when exiting run mode.

Track mode: "track" will cause analogue output to track input gas value during all modes.

Pressing the "**F3**" key will bring you to the second page of the **CONFIGURATION MENU**.

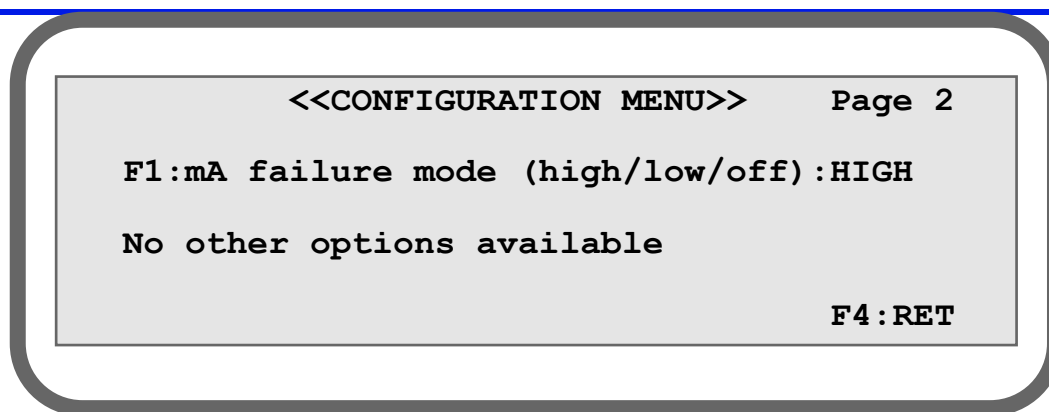

Figure 18 - CONFIGURATION MENU - PAGE 2

5.3.4 mA failure mode

mA failure mode “**F1**” : in the case of an “underscale”, “over scale”, “low flow” or “plasma off”, this option will set the 4-20 mA output : “off “(always remain between 0 and 20 mA, even if an error occurs), “low” (below 4 mA), or “high” (higher than 20 mA).

If you have any options, you will find them described in section 4.2.5 of this manual.

You exit the configuration section by pressing **F4**. The analyzer will display the first page of the **CONFIGURATION MENU**. Pressing **F4** again brings up the **MAIN MENU**.

This is the standard configuration. Other menus may appear if your analyzer has other optional features (serial port, fully automatic calibration, digital I/O, etc.).

NOTE: When you select the automatic ranging feature, the scale selection is based on analogue to digital count value or ppm value, based on which one reaches the maximum value for the scale in use.

5.4 Calibration

The calibration menu is shown in Figure 19 In this section, you have to enter the value in ppm of your zero calibration gas and your span calibration gas. The recommended values are between 0 and 20% of the full scale for the zero value, and between 80 and 95% of the full scale for the span value.

For example, a zero gas of 2.0 ppm and a span gas of 8.0 ppm are excellent values for X10 range. Once the span value is entered, the analyzer will automatically select the proper operating scale. For this reason, you must wait for signal stabilization before sampling the value for calibration.

From **MAIN MENU**, when you press the “**F2**” key, the **CALIBRATION MAIN MENU** is displayed on the analyzer. See Figure 19 - MAIN CALIBRATION.

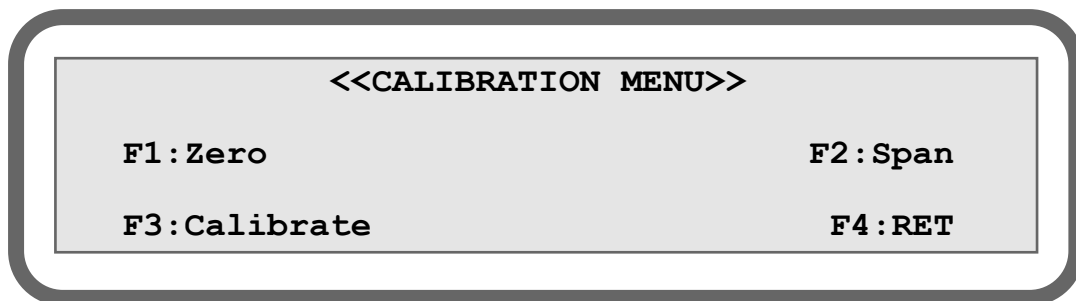

Figure 19 - MAIN CALIBRATION

You enter your zero calibration gas value in ppm, as well as your span calibration gas value. This is done by selecting “**F1**” for the zero value, and “**F2**” for the span value. Figure 20 and Figure 21 show the display for each selection.

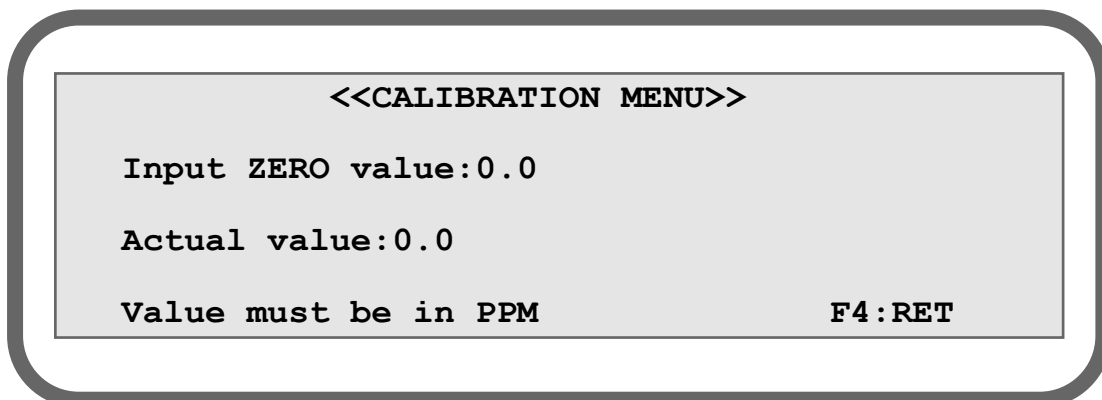

Figure 20 - DISPLAYED WHEN ENTERING ZERO VALUE

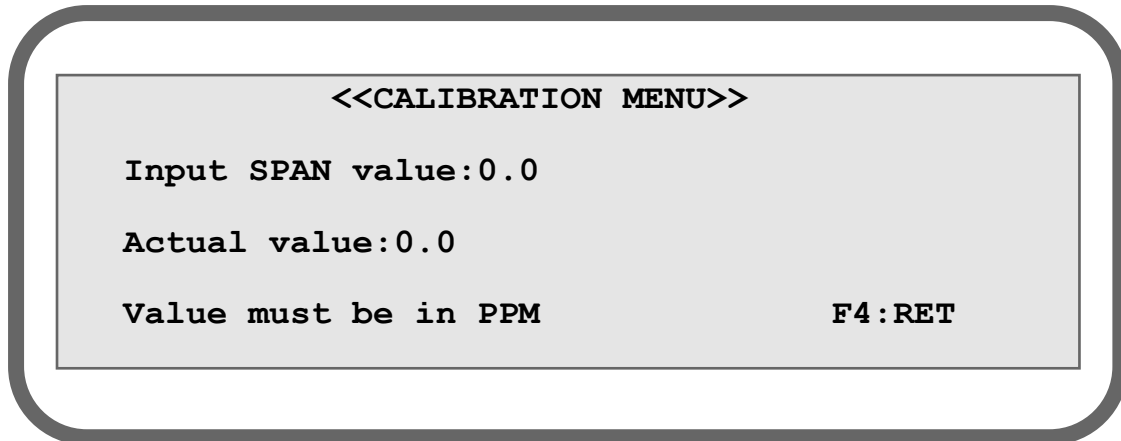

Figure 21- DISPLAYED WHEN ENTERING SPAN VALUE

The analyzer will automatically select the appropriate range based on the span value entered.

When you have entered a value and pressed the "E" key (E for enter), the processor checks the format, evaluates it and validates it. If everything is OK, your value will be redisplayed in the actual value field. If not, the value is rejected, the input field is cleared and the actual value is left unchanged.

If you made an error when entering your value, just press enter and start over.

Once you have entered the zero and the span values, select "F3" to get the **CALIBRATION SUB-MENU**.

The following figure shows this sub-menu:

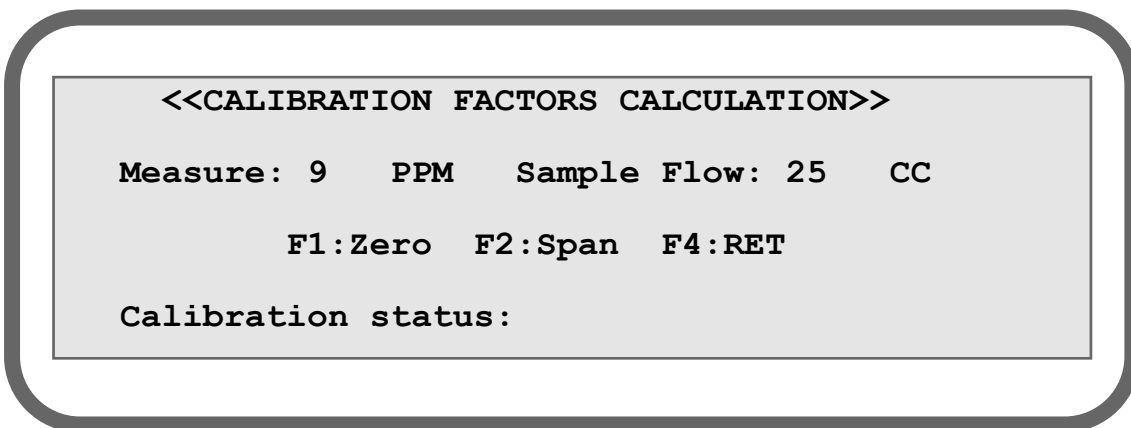

Figure 22 - CALIBRATION SUB MENU

The display shows the actual ppm of nitrogen value and the actual flow in cc. If the unit is started up for the first time or you replace the calibration gas with a new value, the ppm display has no meaning. This can be zero or off scale.

In order to calibrate the unit properly, all lines and regulators on the calibration cylinders must be completely purged. Allow the zero gas to flow into the analyzer. After 10 minutes of the zero gas flowing into the analyzer, select **"F1"** on the keypad. You will be asked for a confirmation to re-zero, select **"YES"**, at this moment this message will be replaced by **"PLEASE WAIT"**, indicating the sampling of the analogue input. This message is displayed for 5 seconds.

NOTE: *an indicator is displayed on the right of the confirmation message informing the user if the re-span or the re-zero has not been performed yet.*

After this delay, the **"ZERO DONE"** message is displayed. Now, allow the span gas to flow into the analyzer for 10 minutes or until the displayed measure value is very stable. Select **"F2"** on the keypad. Again, you will be asked for a re-span confirmation, select **"YES"**, at this moment, again, this message will be replaced by **"PLEASE WAIT"** on the display for a certain amount of time. When this step is done, the **"SPAN DONE"** message is displayed; the span gas value is shown on the left corner of the display. Recheck zero and, if necessary, calibrate a second time.

When the calibration procedure is finished, go back to the **CALIBRATION MAIN MENU** by pressing **"F4"** on the keypad. From the **CALIBRATION MAIN MENU**, select **"F4"** again to go back to the **MAIN MENU (TOP LEVEL MENU)**.

5.5 Diagnosis

Pressing "F3" from the **MAIN MENU** will bring you to the **DIAGNOSTIC MENU**.

The diagnostic feature of the analyzer gives you the opportunity to verify the output of the analogue to digital converter count value and check the 4 - 20 mA output.

If you have any options other than standard, you may also verify them (digital and/or fully automatic calibration option). Please refer to the appropriate section of this manual.

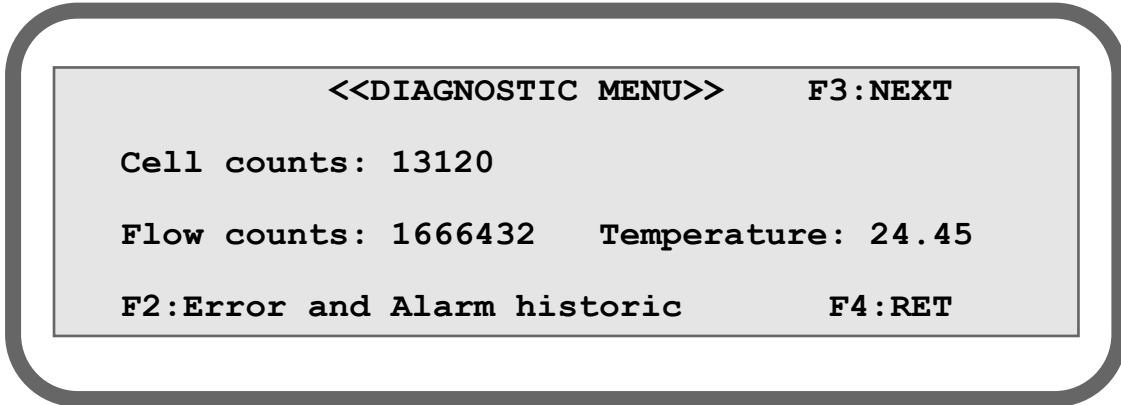

Figure 23 - DIAGNOSTIC MAIN MENU

In the diagnostic menu the cell counts and flow counts are displayed. It is very useful to verify stability and cell offset.

By selecting "F2" it is possible to see the error and alarm historic menu.

"F3" brings you to the second diagnostic menu.

By pressing the "F2" key, it is possible to control the analogue output manually. By selecting "F4: RET", the system displays the **DIAGNOSTIC MAIN MENU** again. The display looks like the following figure.

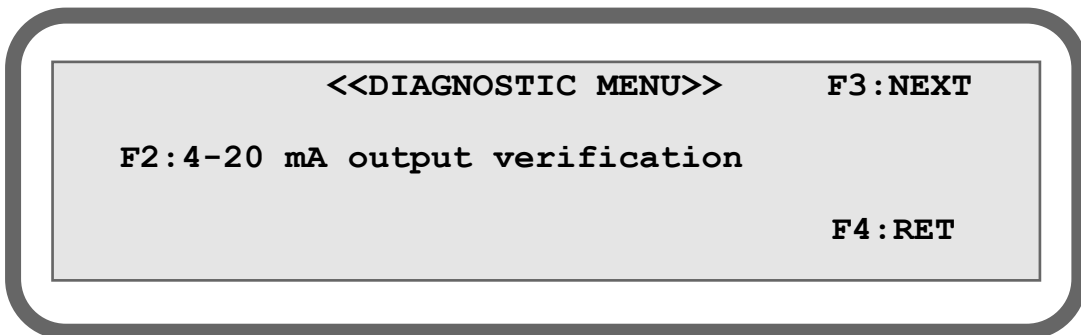

Figure 24 - DIAGNOSTIC MAIN MENU

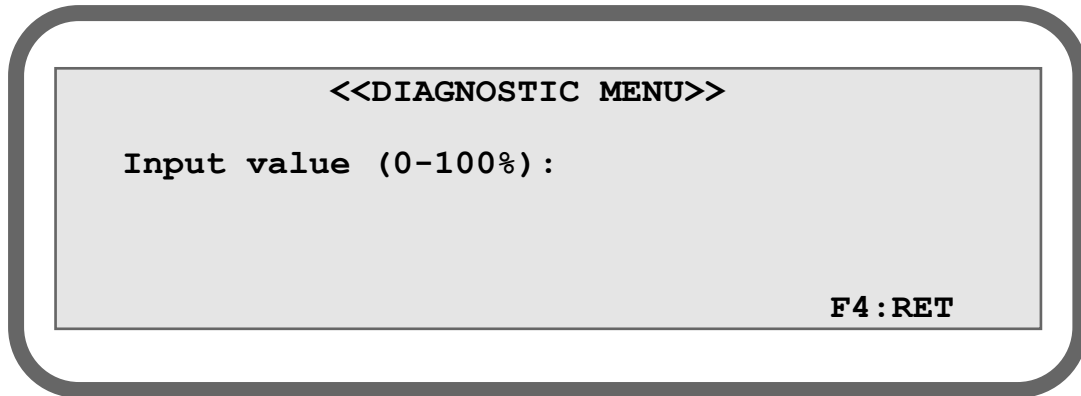

Figure 25 - DIAGNOSTIC MENU

You need only enter any integer number value between 0 and 100 % and press the "E" key for enter. Zero (0) is for 4 mA and one hundred (100) for 20 mA. This makes it easier to calibrate remote monitoring system and also makes it faster to verify the hardware part for the 4 - 20 mA signal isolation module.

NOTE: *the analogue output mode selected from the **CONFIGURATION MENU** ("track" or "hold") will affect the 4 - 20 mA output. Set the analogue output mode in "hold" for 4 - 20 mA output verification. If not, the 4 - 20 mA will still track input gas value.*

5.5.1 Error and Alarm Historic

This menu is very useful. You can see the last 25 alarms with the time and the date. Pressing “F1” from the **DIAGNOSTIC MAIN MENU** brings you the newest errors and “F2” the oldest. For example, if a low flow error occurs at 9:34:37, the error and alarm historic menu will display the “**LOW FLOW**” message with the hour and the date. When the flow is restored, the same message is displayed with “**OK**”. For example, if the low flow is restored at 10:23:01, the error and alarm historic menu will display “**LOW FLOW: OK**” with the date and the time as in the figure below.

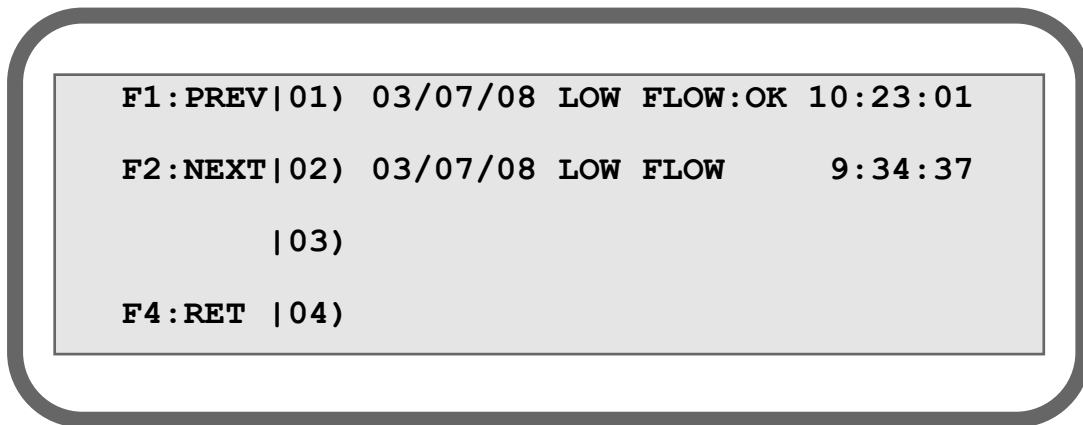

Figure 26 - DIAGNOSTIC MENU

Below is a list of possible errors and their significance:

LOW FLOW: The flow on sample is smaller than 10 cc/min (10 sccm).

PLASMA OFF: The plasma is shut down. Occurs when there is low flow for 30 seconds or when the starting count is not reached.

STARTING: The plasma is trying to start.

WAITING: The system is waiting to preserve the valve. This error occurs 1 minute after the plasma is turning off. The system waits 2 minutes before trying to re-open the valve.

OVER SCALE: The impurities value is greater than scale.

UNDER SCALE: The impurities value is smaller than scale.

ALARM 1: Alarm 1 set point is reached.

ALARM 2: Alarm 2 set point is reached.

AUTCAL FAIL: This error occurs when the auto calibration failed.

5.5.2 Serial number

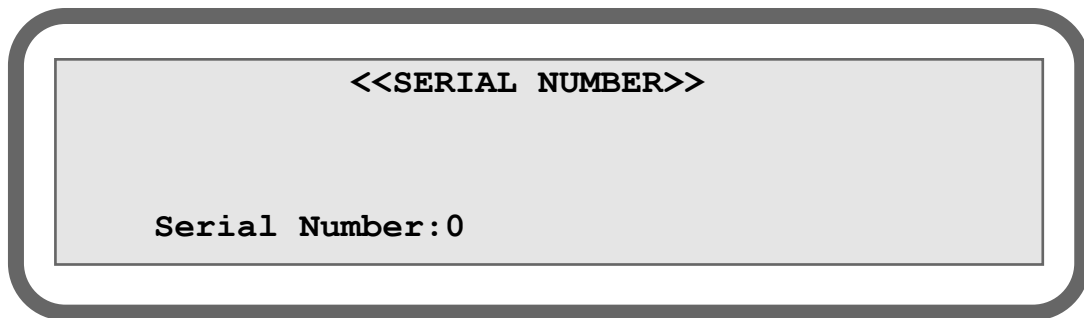

Figure 27 - SERIAL NUMBER MENU

It displays the analyzer serial number, which corresponds to the one written at the back of the analyzer. This can be useful if the back of the analyzer is not accessible.

5.6 Run

Most of the time, you will be in this mode, which displayed the following screen that is accessible by pressing "F4" from the **MAIN MENU**.

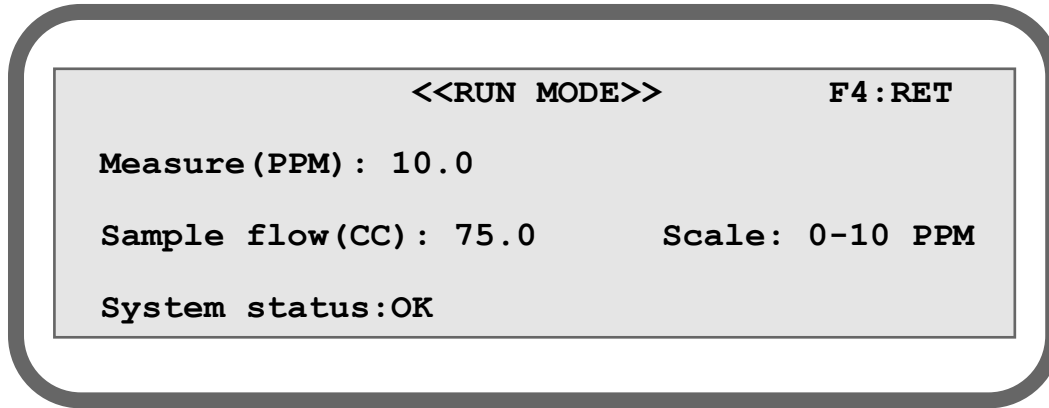

Figure 28 - RUN MODE

In this mode, the following information is displayed: measurement in ppm, flow in cc, system status, and range in use.

The 4 - 20 mA output is refreshed to reflect the level of impurities according to the scale in use. If you have the digital output option, it can be connected to a remote system to indicate the Scale in use.

If from the **CONFIGURATION MENU** you have selected auto-ranging, the scale will change according to the ppm value. If you have selected manual ranging, you must select the desired scale by pressing the "1" key for minimum range, the "2" key for medium range and the "3" key for maximum range.

In both cases, i.e. manual or auto ranging, the actual scale in use is shown on the display.

The gas sample flow is always displayed. Normally, the value displayed is the value entered in the **CONFIGURATION MENU** for the sample flow set point. The value may change when you select different gas streams or if you get too much inlet pressure variation. The inlet pressure must be stable - between 34 kPa (5 PSI) to 69 kPa (10 PSI) for best results.

In the run mode, you may get a status message. Normally, the "OK" message is always displayed. Below is a list of messages and their corresponding meaning:

OK: No problem.

STARTING: Boosted power is applied to the plasma generator for start up. Normally displayed for a short period of time, but it may take as long as 30 to 45 minutes to start the plasma, depending on gas condition or if cell temperature is too cold.

Other messages can be displayed where the ppm value is normally displayed. You may get **"Under scale"** if the cell count or the calculated ppm value is too low for that scale. **"Over scale"** will be displayed if the cell count or calculated ppm value is too high for the scale in use. **"Plasma off"** will be displayed if the plasma is off. **"Waiting"** will be displayed if the plasma stays off for about 1 minute. In this case, the sample flow will be stopped to protect the valve. This is a short time operation, however, **the sample must always be connected and flow must pass thru the analyzer.**

Other messages can appear depending on options or custom features ordered (auto-zero, auto-span).

When an error is detected, the status (ST) digital output will be deactivated (contact open).

NOTICE: When the flow is lower than 20 cc for longer than 30 seconds, an internal relay will shut down the plasma generator and the appropriate message will be displayed. When the flow comes back to normal, the generator restarts.

5.7 Special consideration about the 0 - 1 ppm range

When the 0 to 1 ppm range is selected, the system is very sensitive. The display resolution is fixed at 10 ppb. In order to use this range efficiently, it is very important that the connections be leak-free, that there is no moisture and no quick connector and that the unit is installed and started up properly. It may take some time to get a stable reading. On this range, the response time is longer. The by-pass flow must be constant, and vent line pressure must be at atmospheric pressure. Do not forget: NEVER USE LINES OTHER THAN STAINLESS STEEL FOR THAT TYPE OF MEASUREMENT.

It is normal to see the display reading change slowly on this range.

If you analyse pure argon on this scale, you will get a good approximation of its quality.

It is possible to verify and calibrate this range using the flow dilution technique instead of a gas cylinder. It is very difficult to use gas cylinders for calibration on this range, because very careful handling is required. We use the dilution technique.

5.8 Hidden Menu

By pressing “1”, “2”, “3” and “E” from the Main Menu, the **HIDDEN MENU** opens.

5.8.1 Starting Count

The starting count value is the threshold value where the analyzer switches from starting mode to normal mode.

If the cell counts (value from the analogue to digital converter; this value may be observed under diagnostic menu) is under the starting count value, higher power is applied to the cell by the plasma generator. Once the plasma has started, the cell counts should become higher than the starting count value and the power will come back to normal. If for any reason, the cell count value with the normal power applied to the cell is too close or oscillates around the starting count value, the analyzer will go back and forth between starting and normal mode.

To get rid of such situation, you should enter a new (lower) threshold value. To enter a new value just use the numerical keys on the keypad followed by “E” key. The value must be between 0 and 16,777,215 counts. The default value is normally just what the system needs and under normal conditions this value should not be changed. This value may need to be adjusted over the year.

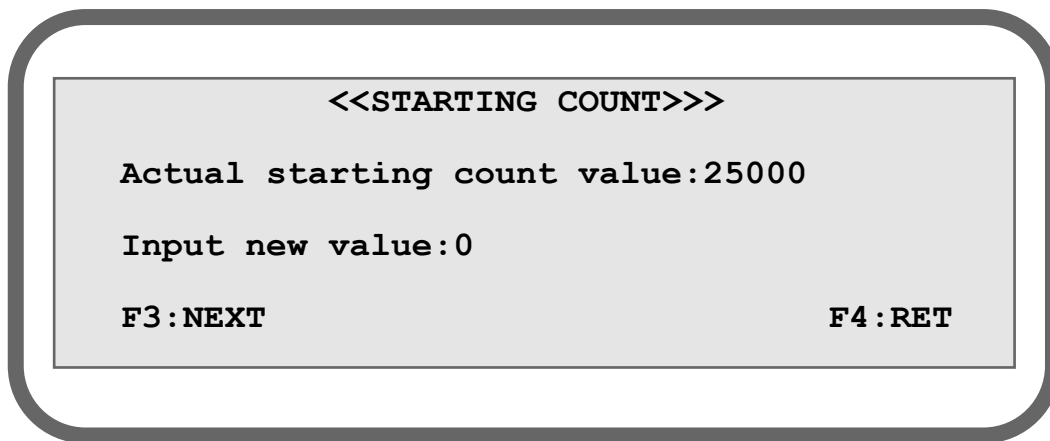

Figure 29 - HIDDEN MENU, FIRST PAGE

Minimum: 0 counts

Maximum: 16 777 215 counts

Resolution: 1 count

5.8.2 Temperature Coefficient

This menu gives the possibility to enter coefficient that will be used for system temperature variation. Using these factors, the software will do a temperature compensation to minimize temperature drift. There are two factors, one for the offset and another for the gain. The temperature affects the baseline of the instrument and the sensitivity. These factors are entered at the factory during temperature drift tests. Most of the time these factors will be set to 1.000 and should not be changed. If you suspect there is an error call Servomex to get the exact procedure to perform the temperature tests.

Press F1 to access the **TEMPERATURE OFFSET MENU**.

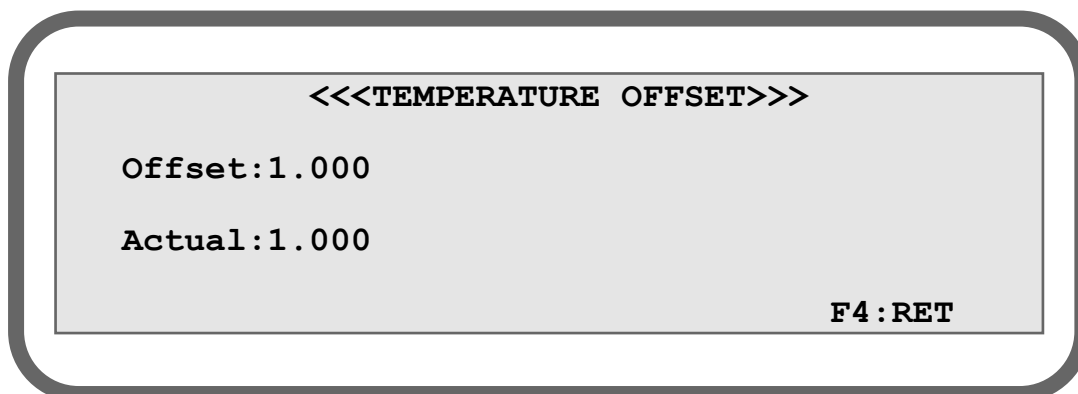

Figure 30 - TEMPERATURE COEFFICIENT

Minimum: 0

Maximum: 2

Resolution: 0.001

If you have to change the offset compensation factor, enter the value with the numeric keypad and then, press “**E**” to validate the new value.

Press “**F2**” to access the temperature gain menu.

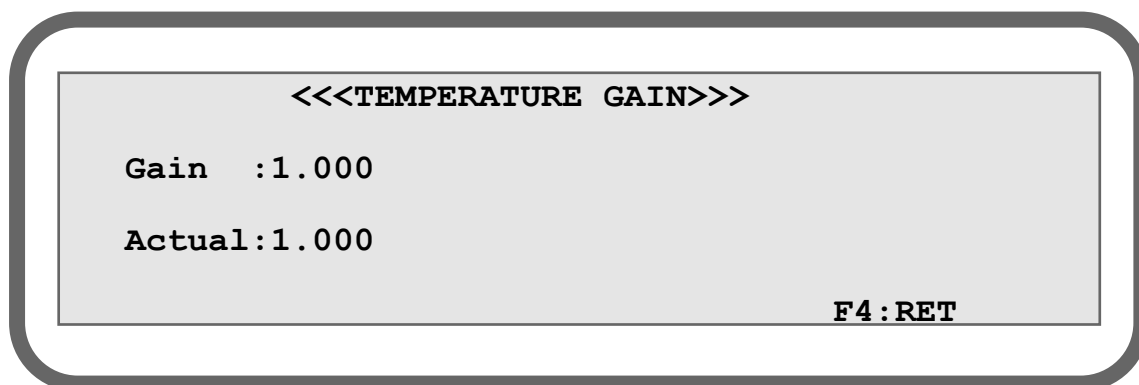

Figure 31 - TEMPERATURE GAIN

Minimum: 0

Maximum: 2

Resolution: 0.001

If you have to change the gain compensation factor, enter the value with the numeric keypad and then, press “E” to validate the new value. The menu to enter the compensation factor for the offset looks the same as the one for gain.

N.B: The ambient temperature is saved at each calibration. This value is compared with the actual ambient temperature to calculate the new “compensated” ppm value.

5.8.3 Time and date setting

When you enter in the time and date setting menu, the following menu appears. Enter time first, using the numbers on the keypad. For example, if you wish to enter 15:45:02, you only have to do the following steps.

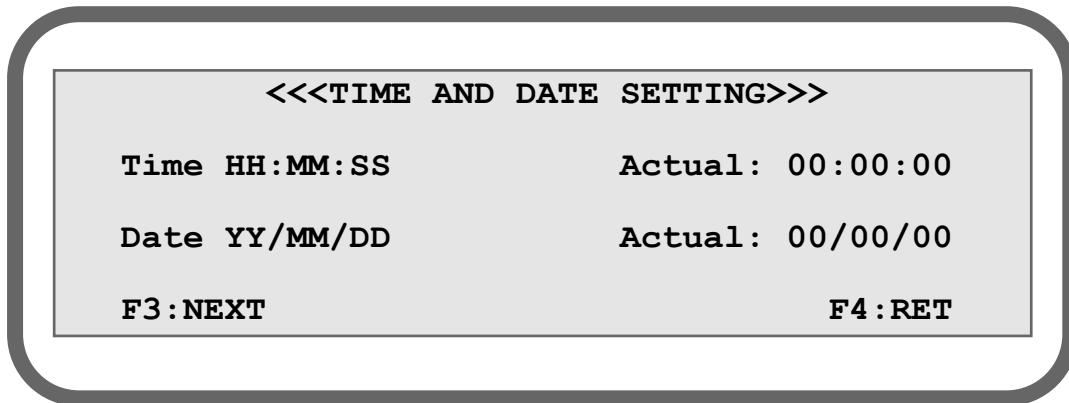

Figure 32 -TIME AND DATE SETTING (1)

- 1- Enter the number 15 on the keypad. Then, press enter.
- 2- Enter the number 46 on the keypad. Then press enter.
- 3- Enter the number 23 on the keypad. Then press enter.

Now, the menu is supposed to look like the following screen.

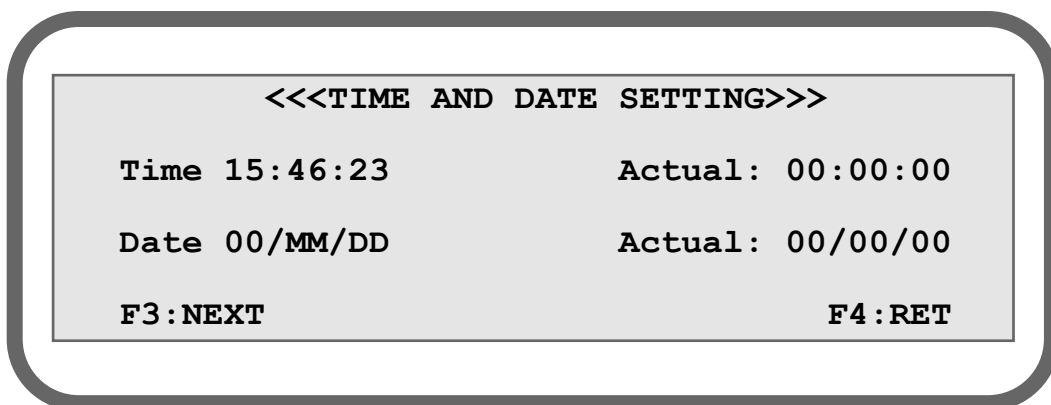
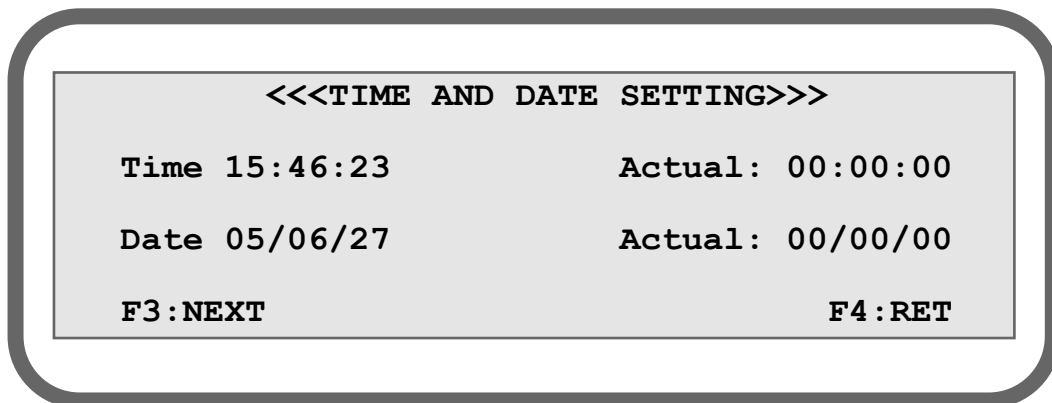

Figure 33 - TIME AND DATE SETTING (2)

When you enter the time, you are obliged to enter the date. You only have to enter the year,



month and day like you did in the preceding steps for the time.

Figure 34 - TIME AND DATE SETTING (3)

When you enter the day and then press enter, the analyzer refreshes the actual time and date and the menu should look like the following screen.

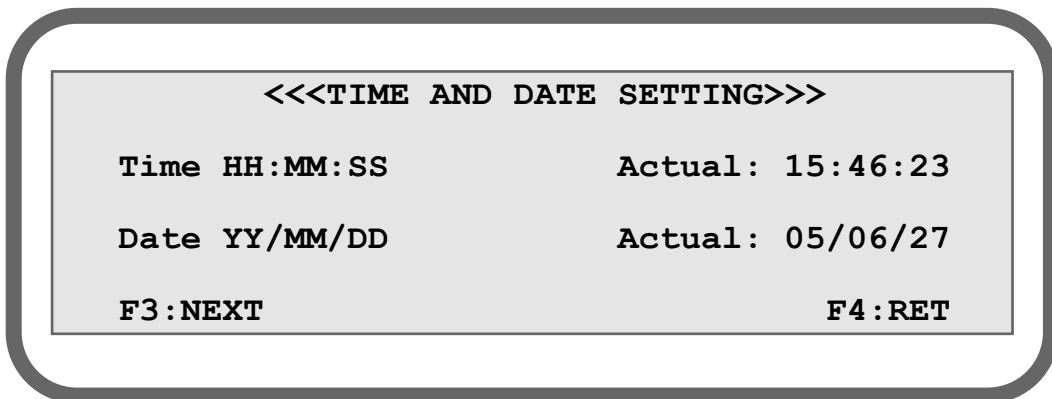

Figure 35 - TIME AND DATE SETTING (4)

If you enter an incorrect value, the analyzer clears the field and you are asked to enter a new one.

5.8.4 System Gain

This value is used to adjust the last stage of amplification. If for any reason the same amount of impurity gives less signal, you may adjust this valve to set the amplification. You may see it as a span potentiometer.

N.B.: You must recalibrate the analyzer each time you change the system gain.

The smallest gain is 2 and the highest is 1000

Minimum: 2

Maximum: 1000

Resolution: 0.01

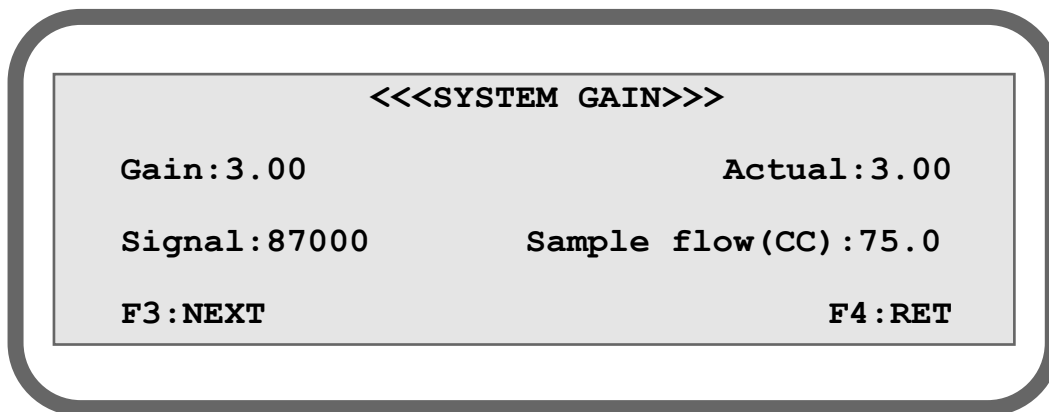
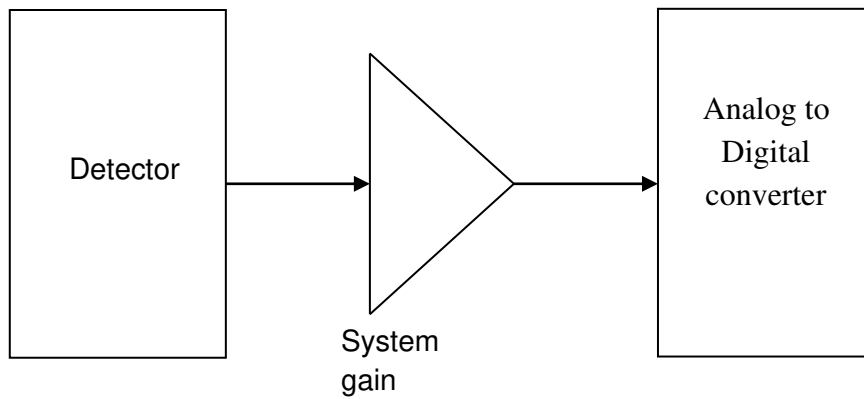

Figure 36 - SYSTEM GAIN

5.8.5 PID values

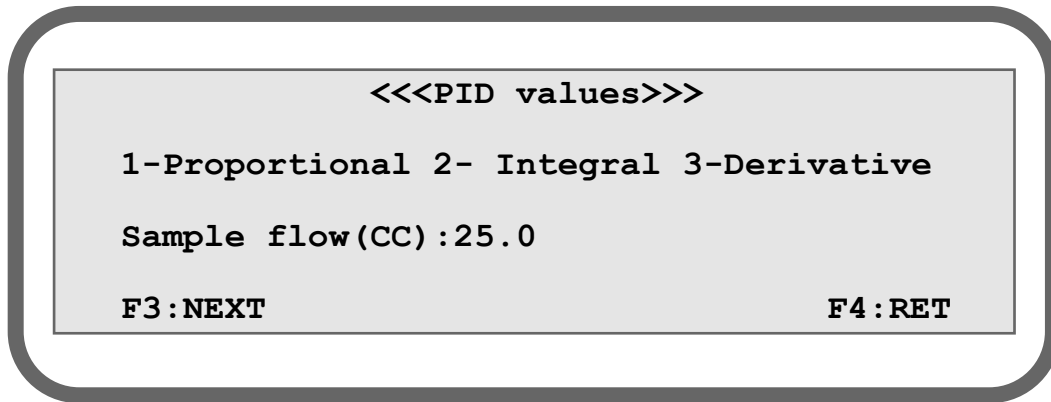

Figure 37 - GAS FLOW PID VALUES

The PID values are the proportional, integral and derivative constant of the loop controlling the gas flow. Depending on the gas flowing in the analyzer, the PID values could have to be changed in order to obtain a stable flow. To modify any of the three constants, press “1”, “2” or “3” respectively for the proportional, integral or derivative value.

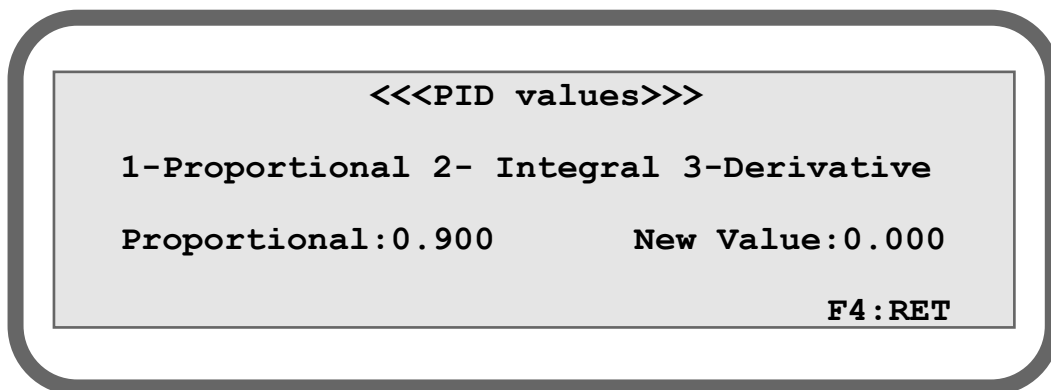

Figure 38 - CHANGING A PID VALUE

The screen will display the preceding figure. Type a new value on the keypad and press E (Enter) to update the current value. Press “F4” to modify another value or to leave the menu.

5.8.6 Lock range

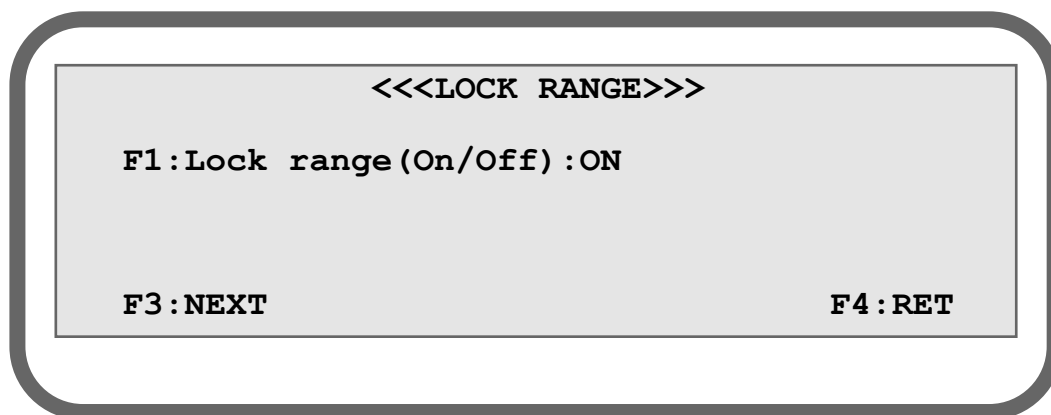

Figure 39 - LOCK RANGE

Pressing “F3” from the **SYSTEM GAIN MENU** will bring you to the **LOCK RANGE MENU**. The lock range can be set “ON” or “OFF”.

If the lock range is set “OFF”, the user is allowed to manually change the range in the run menu. If it is set “ON” the range cannot be changed.

NOTE: To lock the range, you must disable the auto ranging in the configuration menu.

NOTE: You cannot activate the auto ranging if the range is locked.

5.8.7 Averaging Number

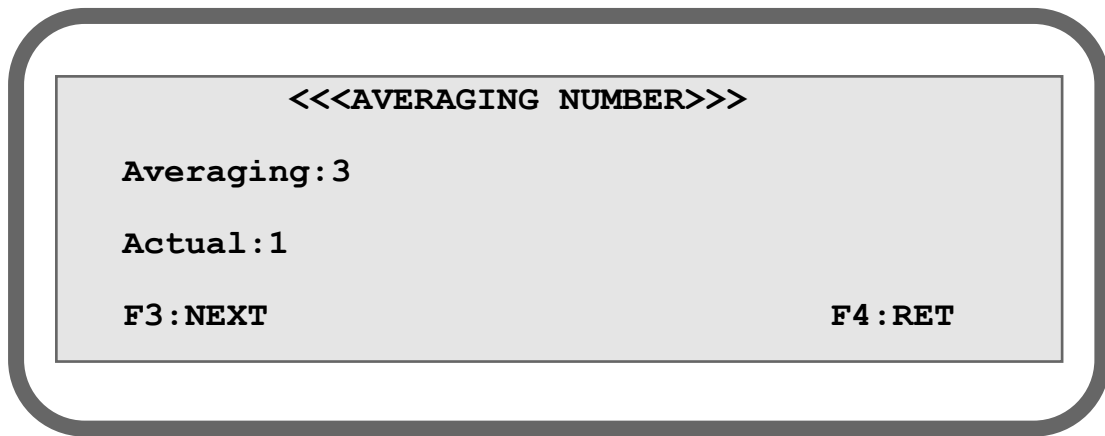

Figure 40 - AVERAGING NUMBER

Minimum: 1

Maximum: 25

Resolution: 1

The software may execute a moving average on the calculated ppm value. This will also affect the response time of the system. The software uses this parameter to determine the number of sample PPM values that are used in its moving average sub-routine. The number of samples ranges from 1 to 25. When entering 1, there is no moving average.

For example, in a 5 point moving average filter, the displayed actual process value will be:

$$\text{Ppm} = \frac{p(1) + p(2) + p(3) + p(4) + p(5)}{5}$$

Where p (5) is the new measure done and p (1) to p (4) are the four previous ones.

5.8.8 Calibration done parameters

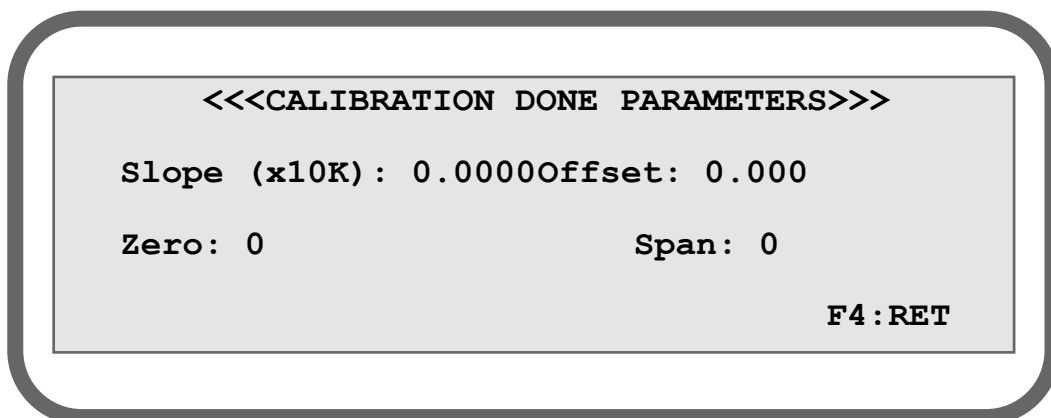





Figure 41 - CALIBRATION DONE PARAMETERS

This menu displays the calibration values calculated by the analyzer. In front of “Zero”, we find the analogue to digital converter counts of the signal measured with the zero gas. In front of “Span”, we find the analogue to digital converter counts of the signal measured with the span gas. The slope and the offset of the equation generated from these two values for further calculations are displayed in front of “Slope (x10K):” and “Offset:”.

6 ROUTINE MAINTENANCE (STANDARD ANALYZER)

	<p style="text-align: center;">WARNING</p> <p>The analyzer must be maintained by a suitably skilled and competent person.</p>
	<p style="text-align: center;">WARNING</p> <p>Do not open or attempt to open the analyzer yourself. If you do, you will invalidate any warranty on the analyzer, and the analyzer may not operate safely or provide accurate measurements.</p>
	<p style="text-align: center;">WARNING</p> <p>Sample and calibration gases may be toxic or asphyxiant:</p> <ul style="list-style-type: none">• Never inspect the inlet filter(s), or service or repair the analyzer while such gases are still connected to it.• If the analyzer is to be serviced or repaired it is important that all pipework is flushed with an inert gas and the analyzer is allowed to freely vent.

6.1 Cleaning the analyzer

When necessary, use a damp (but not wet) cloth to wipe clean the outer surfaces of the analyzer.

6.2 Inspecting/replacing the fuse (when necessary)

	<p style="text-align: center;">WARNING</p> <p>Disconnect power cord from the analyzer before replacing the fuse. If you do not, there will be a danger of injury or death from electric shock.</p>
---	---

	<p style="text-align: center;">WARNING</p> <p style="text-align: center;">Fire Hazard, only use the same type and rated fuse as recommended.</p>
---	---

If you think that an electrical supply fuse has failed, use the following procedure to inspect the fuses and replace it if necessary:

1. Remove power cord.
2. Pry door open at socket with a suitable flat head screwdriver.
3. Lift and swing door into socket.
4. Lift fuse holder out of housing.
5. Install one (1) AG fuse or two (2) metric fuses*.
6. Replace fuse holder into housing.
7. Swing and snap door back in place.

*Install fuses on one side only, do not install both AG and metric fuses at the same time.

7 SPARES



WARNING

Do not use spares other than those specified below, and do not attempt to carry out any maintenance procedures other than those specified in this manual. If you do, you can damage the analyzer and invalidate any warranty.

The standard spares available for the analyzer are shown below. You can order these spares from Servomex or your Servomex agent.

Spare	Part Number
Spare fuse (kit)	S2001FUSE
Plasma spares kit	S2001999
Spare power supply assembly	S2001953

8 STORAGE AND DISPOSAL

8.1 Storage

Refit any protective plastic covers (see Section 2.6) and place the analyzer and any associated equipment in its original packaging before storage. Alternatively, seal it inside a waterproof plastic bag, sack, or storage box.

Store the analyzer and any associated equipment in a clean, dry area. Do not subject it to excessively hot, cold, or humid conditions: see Section 2.2.

8.2 Disposal

Dispose of the analyzer and any associated equipment safely, and in accordance with all of your local and national safety and environmental requirements.



The analyzer is not suitable for disposal in municipal waste streams (such as landfill sites, domestic recycling centres and so on). Refer to next section for disposal requirements in accordance with the WEEE Directive within the EC.



If you send the analyzer to Servomex or your local Servomex agent for disposal, it must be accompanied by a correctly completed decontamination certificate.

8.2.1 Product disposal in accordance with the Waste Electrical and Electronic Equipment (WEEE) Directive

The label shown is fitted to the analyzer.

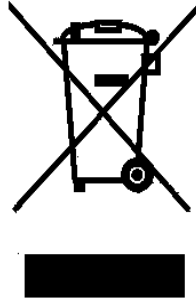

WEEE label

This label identifies that:

- The analyzer is considered to be within the scope of the Waste Electrical and Electronic Equipment (WEEE) Directive.
- The analyzer is not intended for disposal in a municipal waste stream, but shall be submitted for material recovery and recycling in accordance with the local regulations which implement the WEEE Directive.
- For additional information and advice on the disposal of the analyzer in accordance with the requirements of the WEEE Directive, contact Servomex at info@servomex.com or your local Servomex agent.
- If you send the analyzer to Servomex or your local Servomex agent for disposal, the analyzer must be accompanied by a correctly completed decontamination certificate.

9 COMPLIANCE AND STANDARDS INFORMATION

- The analyzer complies with the European Community "Electromagnetic Compatibility Directive":
 1. Emissions: Equipment suitable for use in domestic establishments and in establishments directly connected to a low voltage supply which supplies buildings for domestic purposes.
 2. Immunity: "Basic" – considered appropriate to equipment intended for use in domestic, commercial and light industrial environments.
- The analyzer complies with the European Community "Low Voltage Directive", by the application of:
 1. EN 61010–1 and rated for Category II, Pollution Degree 2.
 2. Transient overvoltage's up to the levels of overvoltage category II.
Pollution degree 2
- The analyzer complies with the Class B digital apparatus requirements of ICES–001 of Canada through the application of EN 55011:2009+A1:2010.
- L'analyseur est conforme aux Conditions B numériques d'appareillage de classe de NMB–001 du Canada par l'application du EN 55011:2009+A1 :2010.
- This analyzer complies with Part 15 of the US FCC Rules for Class B equipment. It is suitable for operation when connected to a public utility power supply that also supplies residential environments.
- The analyzer has been assessed to IEC 61010–1 for electrical safety including any additional requirements for US and Canadian national differences.
- Servomex Group Ltd is a BS EN ISO 9001 and BS EN ISO 14001 certified organisation.

10 CONTACT INFORMATION

Technical Centre

Servomex Group Limited

Crowborough

East Sussex, UK

TN6 3FB

Tel: +44 (0) 1892 652181

Fax: +44 (0) 1892 662253

For Global contact details go to our web site www.Servomex.com and click on "contact us"

APPENDIX 1: AUTOMATIC CALIBRATION OPTION

1 AUTOMATIC CALIBRATION OPTION

1.1 Gas Circuit Description

Analyzers with this option are equipped with 3 solenoid valves. These valves are made of stainless steel and have excellent characteristics for inboard contamination. These valves are used to select between sample, zero and span gas. All gas connections are made on the analyzer rear panel. All gas inlets are protected with a 2 micron frit mounted inside the bulkhead. These are acting as particle filters.

When the analyzer is “ON”, there is always one and only one valve, over the gang of three, being “ON”. So the gas flows through this valve to the common outlet manifold and then to the bulkhead labeled “Trap In”. At the same time, the manifold also supplies gas to the two other unselected valves and the gas exits the valves through the purge port, to a common header, this one being connected to the bulkhead labeled “Purge Vent”. Purging the valves this way ensures that there is no unswept dead leg that would bring contamination of the sample and even eliminates the effect (contamination) of an eventual leaking valve. So, as soon as the analyzer is “ON”, the three valves are swept by the selected gas and there is a flow going to the “Purge Vent” bulkhead. The amount of this flow is as the following table:

Inlet Gas Pressure	Purge Gas Flow
34 kPa (5 PSIG)	40 ml min ⁻¹ (40 cc/min)
69 kPa (10 PSIG)	125 ml min ⁻¹ (125 cc/min)

We recommend keeping the inlet pressure between 34 kPa (5 PSIG) to 69 kPa (10 PSIG).

1.2 System Operation

Calibration of the analyzer may be done manually or automatically at a time interval defined by the user. In both cases calibration gases are selected with SOV1, SOV2 and SOV3. This section explains how to execute a calibration manually and automatically.

NOTE: Zero and span gas values must be set prior to any calibration with a span value bigger than the zero value.

1.3 Entering Zero and span gas values

From the main menu, press “**F2**” to enter the calibration menus of the analyzer.

proceed to the **CALIBRATION MAIN MENU** by pressing “**F3**” and follow standard steps as described in section 5.4

1.4 Manual Calibration

From the main menu, press “**F2**” to enter the calibration menus of the analyzer.

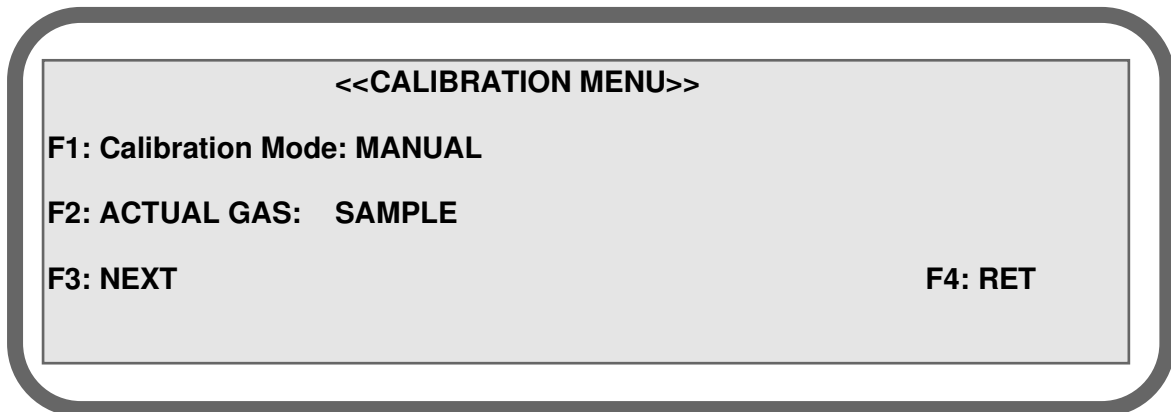

Figure 42 - CALIBRATION MODE SELECTION MENU

Select the “**MANUAL**” mode if you want to perform a manual calibration toggle the calibration modes by pressing “**F1**” until “**MANUAL**” is displayed. Then, toggle between gases by pressing “**F2**” until “**ZERO**” is displayed (SOV2 is energized).

Plasma Gas Analyzer

Be sure that the zero and the span gas values are set (see section 1.2 of this appendix) and let the zero gas flow in the instrument for a while. The zero gas must flow long enough to be sure that the previous gas is purged away and that the system has returned to equilibrium.

When working with Argon, the purge time is quite fast. However, Helium is a poor purge gas. 20 to 30 minutes is then recommended for a purge in helium. You may watch the cell counts in the **DIAGNOSTIC MENU** to make sure that the signal is stable before executing a calibration.

When done, press “**F3**” from the **CALIBRATION MAIN MENU** to enter the **CALIBRATION FACTOR CALCULATION MENU**.

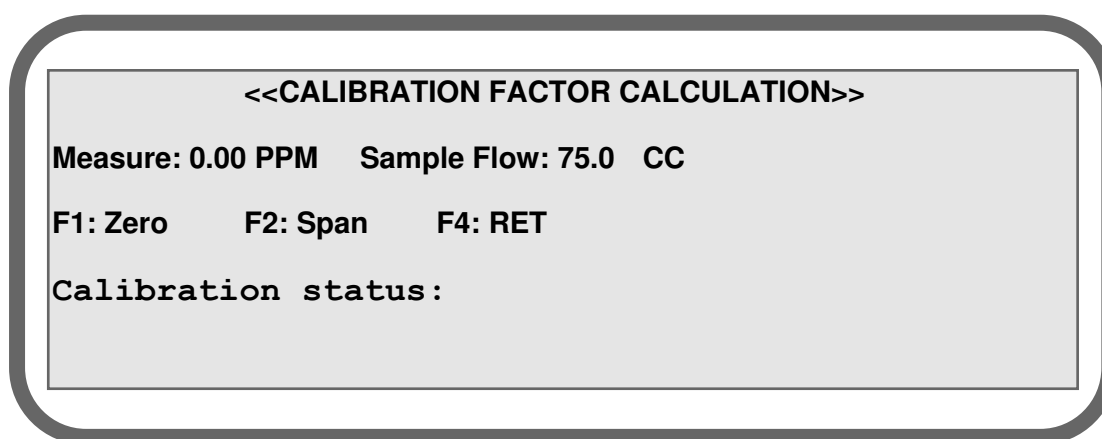

Figure 43: CALIBRATION FACTOR CALCULATION MENU

When the cell counts are stable, press “**F1**” to re-zero the analyzer with the gas currently flowing. Selecting “**F2**” will confirm the re-zero and calculate the calibration factors. The analyzer will display the message “**PLEASE WAIT**” in front of “**CALIBRATION STATUS**” and finally, this message will be replaced by “**ZERO DONE**” to confirm the zero calibration. If the zero and span values were not set properly, “**WRONG CAL. GAS VALUE**” will be displayed. Change the zero and span values, with the span value bigger than the zero value, and try again. If a right re-span was previously performed before this re-zero, “**CALIBRATION DONE**” will be displayed.

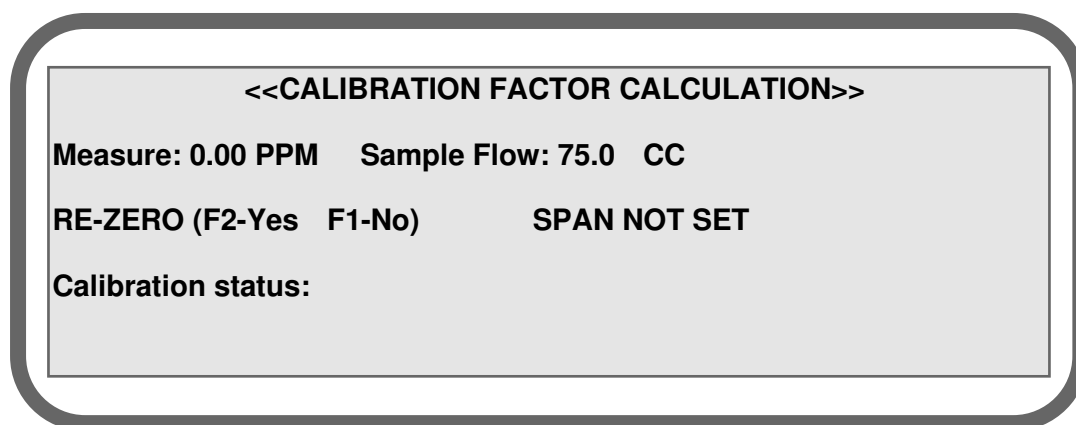

Figure 44 - CALIBRATION FACTOR CALCULATION MENU

To re-span the instrument, a re-zero must have been performed before. You must then allow the span gas to flow in the analyzer. If your analyzer has the auto-calibration option, select **“SPAN”** as the gas source from the **CALIBRATION MODE SELECTION MENU** by using the **“F1”** key.

When this is done, let the gas stabilize, go back to the **CALIBRATION FACTOR CALCULATION MENU** and press **“F2”** to re-span the instrument. Selecting **“F2”** will confirm the re-span of the instrument and will start the factor calculation with the gas currently flowing. **“CALIBRATION DONE”** must be displayed next to **“CALIBRATION STATUS”**. From that point, you may press **“F4”** several times to exit the calibration menus.

NOTE: “WARNING: actual selected gas is” followed by the gas currently selected is displayed if this gas is not the zero gas (SOV2 energized) when a re-zero is about to be performed or if it is not the span gas (SOV3 energized) when a re-span is about to be performed.

The previous procedure was intended for a manual calibration in which the user controls the various steps of calibration. To enable the analyzer to recalibrate by itself, read the following section about automatic calibration.

In this mode, the analyzer executes calibration (i.e. re-zero and re-span) at fixed intervals defined by the user. This duration is called **“TIME BETWEEN CALIBRATIONS”**. When this time interval is reached, the analyzer opens the status contact and energizes solenoid SOV2 to allow the zero gas to flow into the instrument. This gas flows during **“TIME ON CAL.GAS”** which is also defined by the user. When the **“TIME ON CAL. GAS”** is reached, a re-zero (with the zero gas) is automatically performed. The span gas is then selected for a **“TIME ON CAL. GAS”** duration after which a re-span is automatically executed (with the span gas). Finally, the analyzer automatically re-selects the sample gas and closes back the status contact. Calibration timers are re-settled at zero and the cycle is repeated again and again.

1.5 Automatic Calibration Mode

If the 4-20 mA analog output of the analyzer is set to “**HOLD**” mode in the configuration menu, the analyzer waits for the “**TRANSFER DELAY**” before refreshing the 4-20 mA after the re-span has been performed. This delay gives the time to purge the span gas out of the system and avoid undesired bumps on the 4-20mA trending. The analog output remains at the value calculated just before the beginning of the calibration.

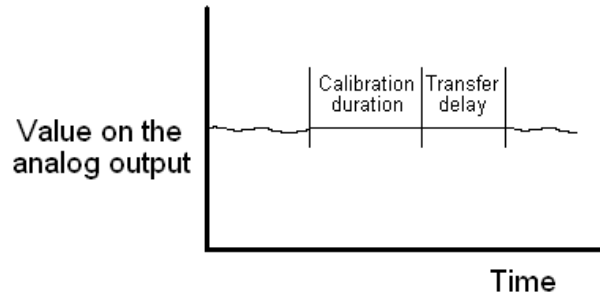

Figure 45 - TRANSFER DELAY

To configure the analyzer to perform automatic calibrations, first set the different timers by going to the hidden menu. To access the **HIDDEN MENU**, go to the main menu and enter the secret code by pressing “1”, “2”, “3”, and “E” consecutively on the keyboard. This brings up the hidden menu. Press “F3” repetitively until the screen of Figure 47 is displayed.

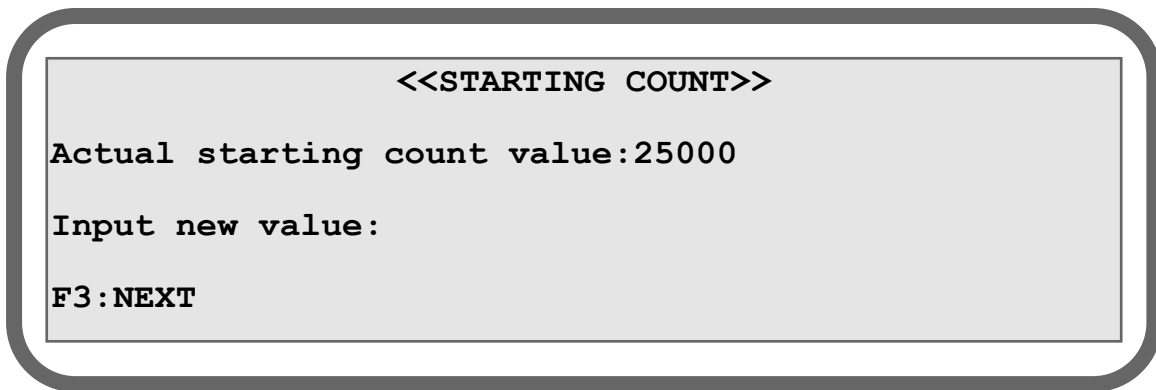

Figure 46 - FIRST PAGE OF THE HIDDEN MENU

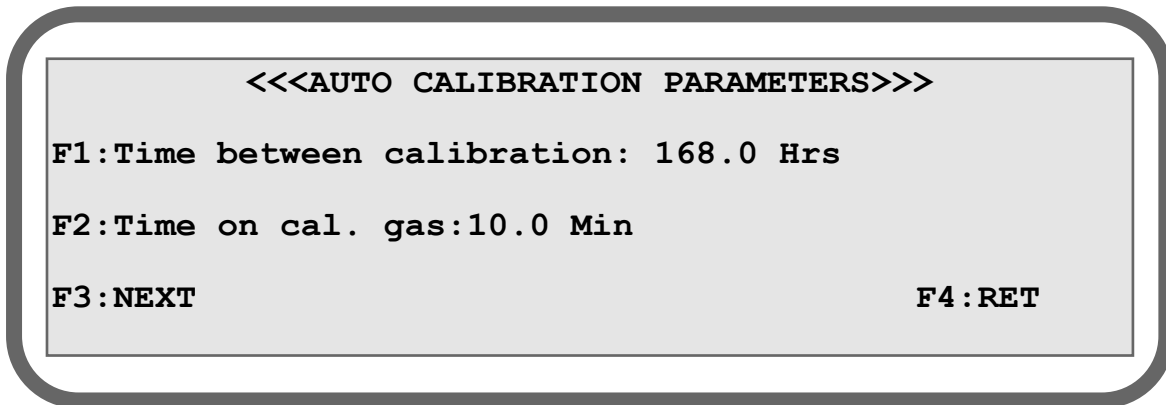

Figure 47 - AUTOMATIC CALIBRATION TIMERS

Minimum: 0

Maximum: 90000.0 (between calibration) and 25000.0 (on calibration gas)

Set the “**TIME BETWEEN CALIBRATIONS**” by pressing “**F1**” and entering the value in hours followed by the E key. Press F2 and enter a value in minutes followed by the E key to set the “**TIME ON CAL. GAS**”.

To set the “**TRANSFER DELAY**”, advance in the hidden menu by pressing “**F3**” until the following page is displayed:

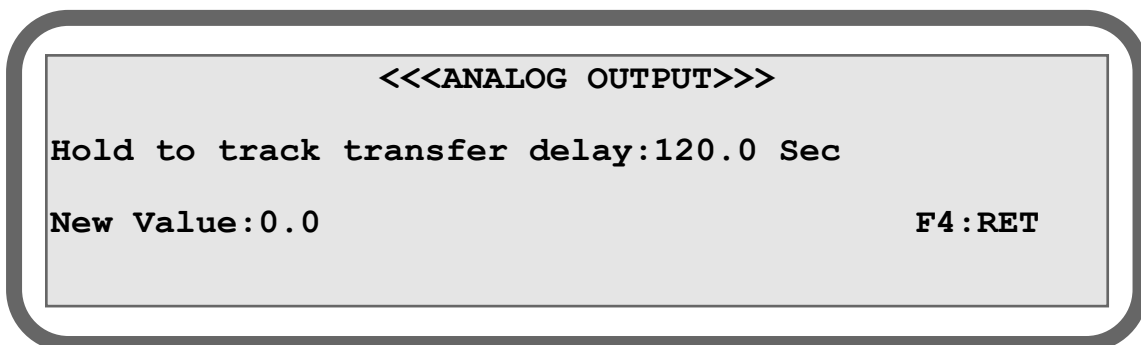

Figure 48 - ANALOG OUTPUT HOLD TO TRACK TRANSFER DELAY

Minimum: 0

Maximum: 90000.0 (between calibration) and 25000.0 (on calibration gas)

Enter a realistic value based on your system configuration, typically around 5 minutes. You should make sure that this value is big enough to allow the sample gas to purge the span gas in the system.

When the proper timing parameters are entered, automatic calibration can be turned on from the calibration selection mode menu Figure 42

Toggle the calibration mode until **"AUTOMATIC"** is selected by pressing F1 in the calibration selection mode menu. The calibration timer **"TIME BETWEEN CALIBRATIONS"** begins to count down from the moment you put the analyzer in automatic calibration mode. You may track the automatic calibration process and monitor both timers **"TIME BETWEEN CALIBRATIONS"** and **"TIME ON CAL. GAS"** from the diagnostic menu. The value displayed next to **"ELAPSED TIME SINCE LAST CAL."** is the number of hours since the analyzer was put in automatic calibration mode. The value displayed next to **"MINUTES ON CAL. GAS"** is the number of minutes the analyzer has spent on calibration gas (zero or span) since the zero or span gas was selected. "0.0" is displayed if the analyzer is not currently performing a calibration.

Furthermore, in the run menu, the gas currently selected is displayed next to **"Gas"**. Note that during an automatic calibration sequence, the status contact remains OPEN.

When the analyzer is in the **RUN** menu during an automatic calibration, the word **"AUTOCALIB"** will be displayed instead of the measure in PPM.

NOTE: *In order to get accurate readings when using auto-calibration mode, the user must enter proper timing values in accordance with the sampling system. Longer purging time are better than shorter ones.*

NOTE: *Only one alarm can be used with the auto-calibration option.*

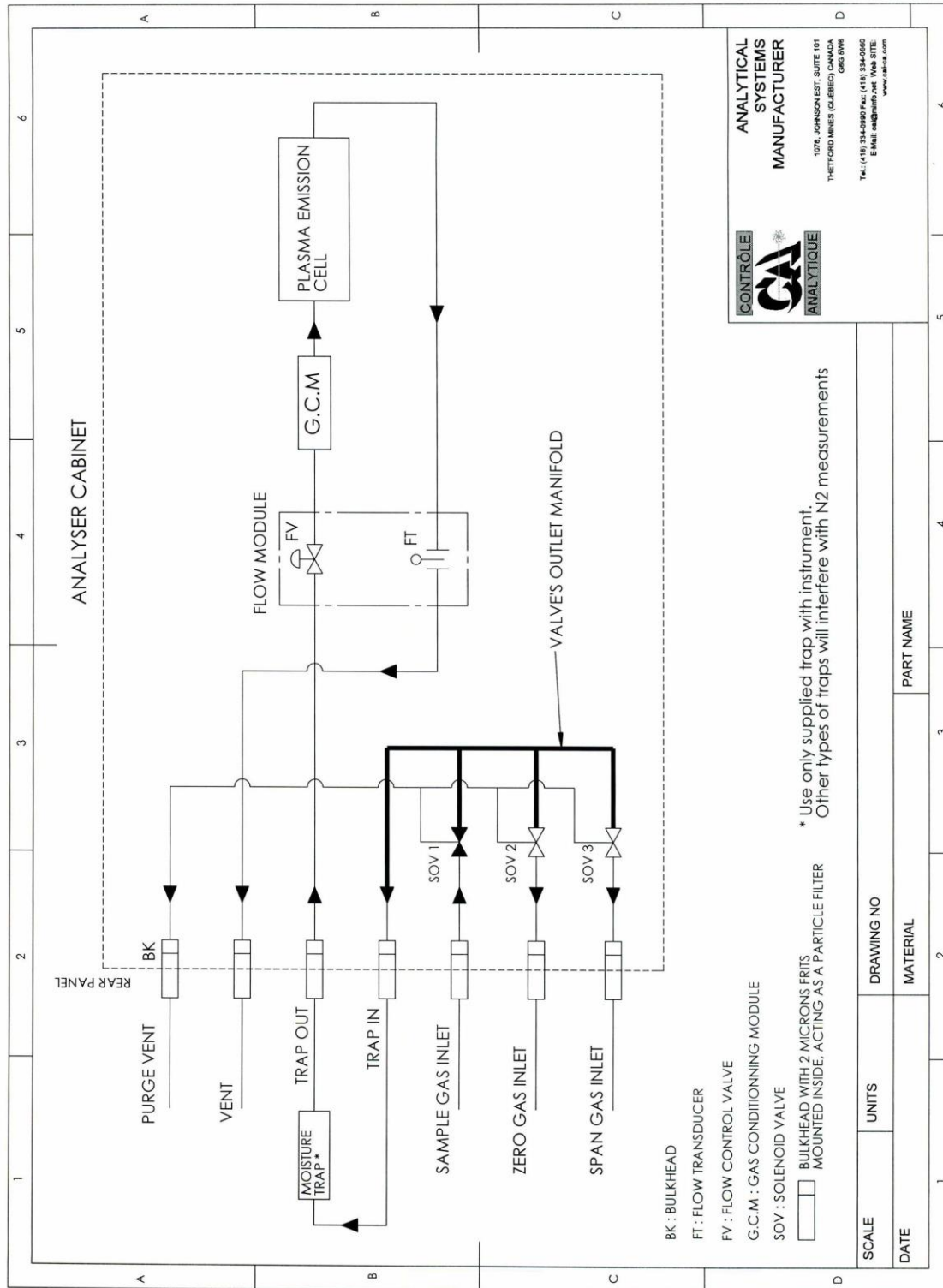

Figure 49 - SERVOPRO PLASMA WITH AUTOMATIC CALIBRATION

APPENDIX 2: TRACE NITROGEN IN HELIUM VERSION

2 TRACE NITROGEN IN HELIUM VERSION

2.1 User Manual

This User Manual applies to both versions of SERVOPRO PLASMA analyzers, i.e. Argon or Helium. Since the most popular version is Argon, the manual refers to Argon as background gas. When Helium is the background gas, replace the word Argon by Helium as required.

2.2 Flow Control System

The flow control valve used in the SERVOPRO PLASMA trace Nitrogen analyzer for Helium background is the same as used in the Argon version. This valve is not a tight shut off valve. Its purpose is to maintain the flow at the default flow set point, i.e. 75 cc/min. It is possible to have a little flow (usually not more than 10 cc/min for inlet pressure of 10 psig) with a flow set point value of 0 cc/min. This is acceptable for normal operation. Note that the plasma will shut off when the real flow is below 10 cc/min. The analyzer should be operated and calibrated with a flow set point of 75 cc/min and stable inlet pressure. The recommended inlet pressure range is between 5 to 15 psig, ideal being 10 psig.

2.3 Leaks

The most critical point in trace Nitrogen analyzer is to avoid the pollution of the sample stream. The leak integrity of the sampling and calibrating system is critical for the performance of the analyzer. Be aware that leaks are more critical with Helium than Argon. Furthermore, the sample must be as dry as possible. You should use a molecular sieve 3A trap to keep the sample dry.

2.4 Working with Helium

It is a challenge to work with Helium in an on line continuous measurement of ppm N₂. The Helium molecule size and weight are so small compared to N₂ that special attention must be paid to the sampling system in order to get a better stability.

With Argon, the sampling system operating condition may produce good results. The same condition applied with Helium can lead to unacceptable performance.

Most of the time, when sampling Helium, if line temperature pressure and flow vary, reading will also vary. The stabilization time with Helium is much longer than with Argon.

Points to remember when sampling Helium :

1. Keep a constant and high flow rate in the sampling line. Exhaust the excess flow through a by-pass rotameter.
2. Close to sample point tap or connection, use a small stainless steel electropolish with VCR connection only pressure regulator. The by-pass rotameter with its valve will fix the line flow and the sample point pressure regulator will maintain the line pressure constant.
3. The third parameter: temperature. If the line temperature varies, reading will also vary due to change in equilibrium conditions, change in temperature when sampling Helium will cause reading drift and recovery time will be long if sample flow is low. The best result is achieved if you can heat trace the sampling line and maintain the temperature between 60°C and 75°C. The temperature must be constant.
4. Install the supplied trap at the analyzer inlet.

Use only electropolished stainless steel. Electropolishing is an electrochemical procedure that satisfies the deficient ionic sites of surface metallic molecules. These ionic sites strongly attract polar molecules causing a stronger adsorption effect at that site.

APPENDIX 3: DUAL BACKGROUND ANALYZERS

3 DUAL BACKGROUND ANALYZERS

3.1 NOTE TO THE READER

The SERVOPRO PLASMA trace Nitrogen in Argon or Helium analyzer version is shipped configured for Argon. When changing background gases from Argon to Helium, or vice versa, all the previously in use background gases must be purged before attempting any calibration. Normally this will take up to 24 hours.

3.2 User Manual

This User Manual applies to both versions of SERVOPRO PLASMA analyzer, i.e. Argon or Helium. Since the most popular version is Argon, the manual refers to Argon as background gas. When Helium is the background gas, replace the word Argon by Helium as required.

You must read this addendum to know how to select Argon or Helium backgrounds.

3.3 Flow control system

The flow control valve used in the SERVOPRO PLASMA trace Nitrogen analyzer for Helium background is the same as the one for the Argon version. This valve is not a tight shut off valve. Its purpose is to maintain the flow at the default flow set point, i.e. 75 cc/min. It is possible to have a little flow (usually not more than 10 cc/min for inlet pressure of 10 psig) even if the flow set point value is 0 cc/min. This is acceptable for normal operation. Note that the plasma will shut off when the real flow is below 20 cc/min for more than 30 seconds. The analyzer should be operated and calibrated with a flow set point of 75 cc/min and stable inlet pressure. The ideal inlet pressure range is between 5 to 15 psig.

3.4 Leaks

The most critical point in trace Nitrogen analysis is to avoid the pollution of the sample stream. The leak integrity of the sampling and calibrating system is critical for the performance of the analyzer, no doubt can subsist about this. Be aware that leaks are more critical with helium than with argon.

Furthermore, the sample must be as dry as possible. You should use the supplied trap to keep the sample dry. It is also recommended to have one trap for each calibration cylinder.

3.5 Configuration and operation

3.5.1 Introduction

All configuration, calibration, diagnostic and run menus described in the standard User Manual also apply to the argon/helium version of the SERVOPRO PLASMA series analyzer.

There is a supplementary "**HIDDEN**" menu to select the starting count value and the background operating gas.

3.5.2 HIDDEN menu access

To access the **HIDDEN MENU**, go to the main menu and enter the secret code by pressing "1", "2", "3", and "E" consecutively on the keyboard. This brings up the hidden menu see Figure 50

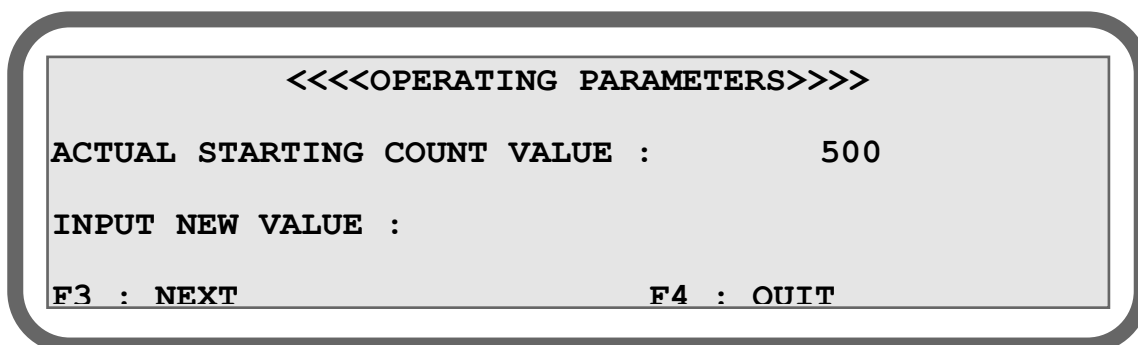

Figure 50 - OPERATING PARAMETERS MENU

The starting count value is the threshold value where the analyzer switches from starting mode to normal mode.

If the cell count value (value from the analog to digital converter; this value may be observed under **DIAGNOSTIC MENU**) is under the starting count value, a higher power is applied to the cell by the plasma generator. Once the plasma is started, the cell count will be higher than the starting count value and the power will come back to normal. If, for any reason, the cell count value with the normal power applied to the cell is too close or oscillates around the starting count value, the analyzer will go back and forth between starting and normal mode.

To get rid of such a situation, you should enter a new (lower) threshold value.

To enter a new value, just use the numerical key on the keypad followed by pressing the "E" key. The value must be between 0 and 1,000,000 counts.

The default value is normally just what the system needs and, under normal conditions, this value should not be changed.

From this menu, by selecting "F3" for next sub-menu, the following menu is brought up on the display.

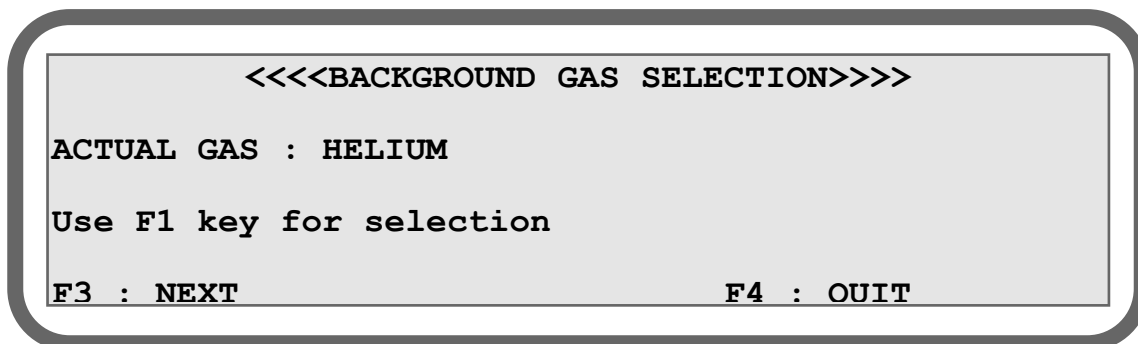

Figure 51 - BACKGROUND GAS SELECTION MENU

This menu is used for display and selection of the background gas type. The background gas may be helium or argon.

The "F1" key toggles between argon and helium. *NOTE : When selecting helium, the sample flow will be set at 75 cc/min. Selecting back argon will set the sample flow set point at 75 cc/min. You may change later the sample flow set point in the configuration menu. See User's Manual.* After the selection is done, use "F3" to go in the next menu or "F4" to quit.

Figure 52 below shows the next menu.

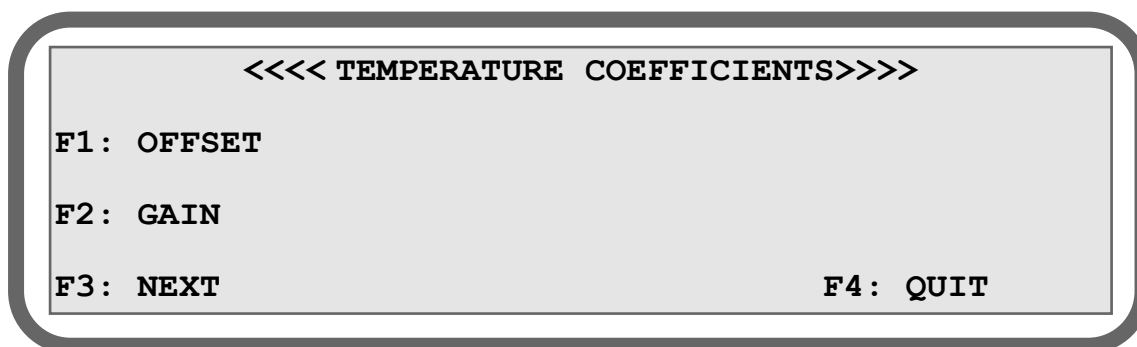

Figure 52 - TEMPERATURE COEFFICIENT MENU

The temperature coefficients are defined during bench testing at the factory. These values are used to do temperature compensation for ambient temperature change if required. You should not change this value unless you know how to proceed for temperature bench marking. A value of 1.000 cancels the temperature compensation.

CAUTION

The metal based trap is made with ¼" O.D. S.S. tubing. Don't allow air or high level of O₂ to flow in it because excessive heat would be generated. Install the trap only when all lines are purged. This trap must be installed to get good results when operating under helium. When the trap has been depleted it must be replaced. We strongly recommend keeping one in stock.

APPENDIX 4: INTERFACE FOR EXTERNAL VALVE BOX

4 INTERFACE FOR EXTERNAL VALVE BOX (VB)

4.1 Description

The analyzer is available with an enhanced RS-232 serial communication port to interface with an external Valve Box.

The enhanced RS-232 port offers stream selection of the Valve Box, remote initiation of auto-zero and auto-span calibration, and additional information for analyzer identification, range, calibration status, and alarm status.



This enhanced RS-232 interface has been tested with a Teledyne VB-3 unit. Not all Valve Boxes are the same. Check with manufacturer of the valve Box that your selected model is compatible with the analyzer..

4.2 Main Menu

An analyzer fitted with the enhanced RS-232 port is identified by the characters “vb” placed next to the software version on the Main Menu.

```
TRACE GAS ANALYZER VX.XXvb
<<MAIN MENU>>
F1: Configuration          F3: Diagnostic
F2: Calibration           F4: Run
```

4.3 Calibration Menu

```
<<CALIBRATION MENU>>
F1: ACTUAL GAS: SAMPLE X
F2: PURGE TIME (minute): 10.00
F3: NEXT
```

Press F2 on the Main Menu to enter the Calibration Menu. From this menu:

Pressing F1 allows selection of the sample stream on the Valve Box. Repeated pressing of F1 will toggle between the different sample options.

Pressing F2 allows a purge time to be configured. Press and hold F2 to select a purge time between 0 and 25000 seconds. This purge allows the system time to reach stability before performing the calibration.

Note: In the calibration factor calculation menu, a purge time will be initiated according to the value previously configured when a zero or a span calibration is manually started. After the purge time, the analyzer will perform the calibration. The purge time is also initiated when calibration is requested remotely.

4.4 Status Data and Commands through the RS-232 Port

The RS-232 serial communication port (standard 9-pin D connector) is used to connect the analyzer to a computer, terminal, or Valve Box. The output data is updated twice a second. The status of the analyzer is reported in the following order:

STATUS, CONCENTRATION, RANGE, ALARM 1 STATUS, ALARM 2 STATUS,
ANALYZER MODE, MODEL NUMBER, SERIAL NUMBER <LF><CR><NULL>

Note that each field is separated by a comma, and the output string must end with <LF><CR><NULL>. A typical string would look like the following:

ST, 37.90 ppm, RA-LO 0- 100 ppm, AL-1 DISABLED, AL-2 DISABLED, A, GFC7000E,
105001<LF><CR><NULL>

The output string is sent through the RS-232 in analyze, span, and zero modes.

The following table describes each field possible combination. Follow the format for each field as close as possible.

Status	Acceptable output	Description
RANGE	RA-LO 0- 10 ppm RA-MED 0- 100 ppm RA-HI 0- 1000 ppm RF-LO 0- 10 ppm RF-MED 0- 100 ppm RF-HI 0- 1000 ppm	RA-LO: Instrument is in the low range and auto ranging RA-MED: Instrument is in the medium range and in auto ranging RA-HI: Instrument is in the high range and in auto ranging RF-LO: Instrument is in the low range and in fixed range RF-MED: Instrument is in the medium range and in fixed range RF-HI: Instrument is in the high range and in fixed range They have to end with the range limits "0- xxxx ppm" Example ranges are in the middle column, the top limit can be any integer number.
ALARM 1 STATUS	AL-1 ON AL-1 DISABLED	Status of alarm 1
ALARM 2 STATUS	AL-2 ON AL-2 DISABLED	Status of alarm 2
ANALYZER MODE	A S Z	A, analyzer is in analyze/sample mode S, analyzer is in span mode Z, analyzer is in zero mode
MODEL NUMBER	8 characters	Model number is 8 characters long or less. It can be letters or numbers.
SERIAL NUMBER	8 characters	Serial number is 8 characters long or less. It can be letters or numbers.
<LF><CR><NULL>	<LF><CR><NULL>	Each output string must end with <LF> Line feed <CR> Carriage return <NULL> Null character in that order

The following table lists the commands that the external Valve Box can send to the analyzer.

Command	Description
as<enter>	Immediately starts an auto-span
az<enter>	Immediately starts an auto-zero
al<enter>	<p>Local Regime. Valve Box is under analyzer control. In this mode the analyzer can be spanned and zero from the front panel of the instrument, and it can control valves in the Valve Box.</p> <p>When analyzer is powered up, it defaults to local regime mode. The Valve Box on receiving the string output through the RS-232 port will send the "ar" command to set the instrument in remote mode if needed.</p>
ar<enter>	Remote Regime. Valve Box is under control of the PLC. The analyzer has the span and zero functions disabled while in Remote Regime, only the Valve Box can initiate span and zero through the RS-232 port

The following table gives the setting requirements of RS-232 port of the Valve Box.

Parameter	Setting
Baud	9600
Byte	8 bits
Parity	None
Stop Bits	1
Message Interval	2 seconds

4.5 Controlling the valves of Valve Box from the analyzer

When the analyzer powers up, control of the Valve Box is set up as Local Regime. The operator can select the sample stream and also issue calibration commands from the analyzer front panel. The corresponding sample valve will be opened in the Valve Box.

The commands sent by analyzer to the Valve Box:@

1<LF><CR><NULL> opens sample valve #1

2<LF><CR><NULL> opens sample valve #2

3<LF><CR><NULL> opens sample valve #3

S<LF><CR><NULL> opens span valve

Z<LF><CR><NULL> opens zero valve