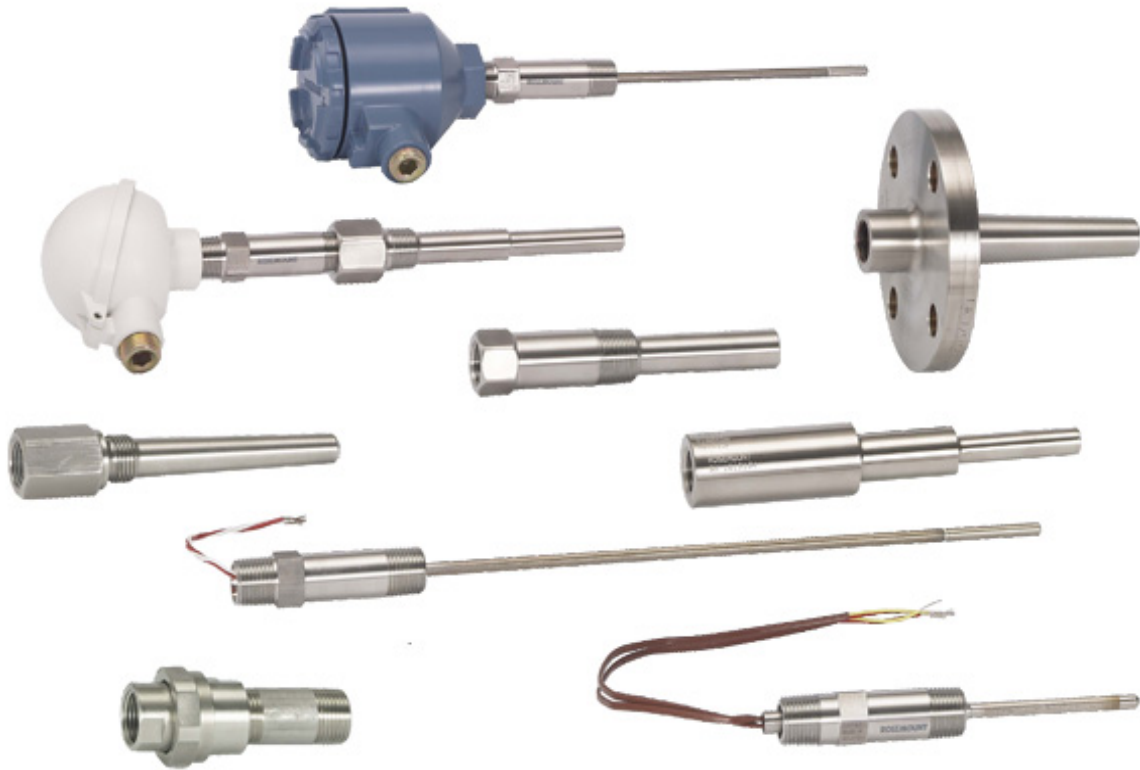


# Volume 1 Temperature Sensors and Accessories (English)



- RTD and Thermocouple offering in single and dual sensor models
- Barstock Thermowell offering in wide range of materials and process connections
- Calibration capabilities for increased measurement accuracy
- Sanitary RTD for hygienic applications

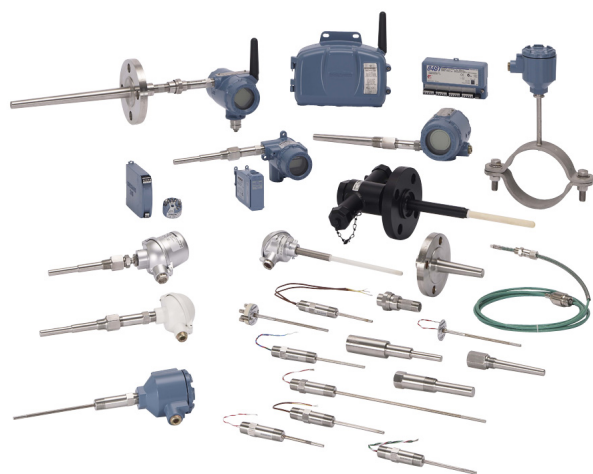
# Rosemount Volume 1 Temperature Sensor and Thermowells

## Optimize plant efficiency and increase measurement reliability with industry-proven design and specifications

- Available in a variety of sensing technologies – RTD and Thermocouples
- All sensor styles and lengths are available in 1/4-in. diameter
- State of the art manufacturing procedures provide robust element packaging, increasing reliability
- Industry-leading calibration capabilities allow for Callendar-van Dusen values to give increased accuracy when paired with Rosemount transmitters
- Optional Class A accuracy for critical temperature measurement points
- Sanitary offering provides sensor assemblies approved for hygienic applications

## Streamline operations and maintenance with sensor and thermowell design

- Spring loaded threaded adapter, general-purpose welded adapter, capsule, and bayonet styles offer remote or integral transmitter mounting configuration



## Explore the benefits of a Complete Point Solution™ from Rosemount Temperature Measurement

- An “Assemble Sensor to Specific Transmitter” option enables Emerson to provide a complete point temperature solution, delivering an installation-ready transmitter and sensor assembly
- Emerson has a complete portfolio of Single Point and High Density Temperature Measurement solutions, allowing you to effectively measure and control your processes with the reliability you trust from Rosemount products

### Contents

Rosemount 68 Sensor and Thermowell .....	4	Series 68 Platinum RTD .....	68
Rosemount 78 Sensor and Thermowell .....	17	Series 78 Platinum RTD .....	70
Rosemount 183 Sensor and Thermowell .....	31	Series 183 Thermocouple .....	72
Rosemount 68Q Sanitary Sensor .....	44	Series 68Q Sanitary Platinum RTD .....	74
Rosemount 58C Cut-to-Fit Sensor .....	47	Series 58C Platinum RTD.....	77
Rosemount 91 Series Thermowells .....	49	Calibration .....	79
How to Decide What to Order .....	59	Mounting accessories .....	86
Spring-Loaded Sensor Dimensions .....	61	Thermowells .....	95
Temperature Sensor Assemblies .....	66	Product Certifications .....	102

## Experience global consistency and local support from numerous worldwide Rosemount Temperature manufacturing sites

- World-class manufacturing provides globally consistent product from every factory and the capacity to fulfill the needs of any project, large or small.
- Experienced Instrumentation Consultants help select the right product for any temperature application and advise on best installation practices.
- An extensive global network of Emerson service and support personnel can be on-site when and where they are needed.



## Rosemount 68 Sensor and Thermowell



The Rosemount 78 Sensor and Thermowell have designs that provide flexible and reliable temperature measurements in process environments.

Features include:

- Industry-standard Pt-100 RTD
- Variety of enclosure and connection head options
- Global hazardous-location approvals
- Calibration services to give you insight to sensor performance
- Calibration certification documentation to accompany sensor
- Assemble to Transmitter option

Specification and selection of product materials, options, or components must be made by the purchaser of the equipment. See [page 69](#) for more information on Material Selection.

**Table 1. Series 68 RTD Sensor Assemblies WITHOUT Thermowell**

★ The Standard offering represents the most common options. The starred options (★) should be selected for best delivery lead time. The Expanded offering is subject to additional delivery lead time.

Model	Product description		
0068	Platinum Temperature Sensor without Thermowell		
<b>Connection head</b>			
R	Aluminum Connection Head, Six Terminals, Flat Cover, Unpainted		★
T	Aluminum Connection Head, Six Terminals, Extended Cover, Unpainted		★
P	Aluminum Connection Head, Six Terminals, Flat Cover, Painted		★
L	Aluminum Connection Head, Six Terminals, Extended Cover, Painted		★
N	Sensor Only with 6-in. PTFE-insulated, 24-gauge lead wires		★
D	Rosemount Aluminum Connection Head with 1/2-in. Entries		★
C	Polypropylene Connection Head		
G	Rosemount SST Connection Head with 1/2-in. Entries		
<b>Sensor type (single element -50 to 400 °C [-58 to 752 °F])</b>			
01 <sup>(1)(2)</sup>	Capsule Style		★
11 <sup>(3)</sup>	General-purpose Style		★
21	Spring-loaded Style		★
31 <sup>(4)</sup>	Bayonet Spring-Loaded Style (available in [X] lengths of 1 to 21-in., increments of 1-in.)		
<b>Extension type</b>		<b>Extension type material</b>	
A <sup>(5)</sup>	Nipple Coupling	300 series SST	★
C <sup>(5)</sup>	Nipple Union	300 series SST	★
N	None (use with Extension Length Option Code 00)	None	★

**Table 1. Series 68 RTD Sensor Assemblies WITHOUT Thermowell**

★ The Standard offering represents the most common options. The starred options (★) should be selected for best delivery lead time.  
 The Expanded offering is subject to additional delivery lead time.

<b>Extension length (E)</b>		
00	0.0 in.	★
30	3.0 in.	★
60	6.0 in.	★
<b>Thermowell material</b>		
N	No Thermowell Required	★
<b>Sensor immersion length (L)</b>		
010 <sup>(6)</sup>	1.0-in.	★
015	1.5-in.	★
020	2.0-in.	★
025	2.5-in.	★
030	3.0-in.	★
035	3.5-in.	★
040	4.0-in.	★
045	4.5-in.	★
050	5.0-in.	★
055	5.5-in.	★
060	6.0-in.	★
065	6.5-in.	★
070	7.0-in.	★
075	7.5-in.	★
080	8.0-in.	★
085	8.5-in.	★
090	9.0-in.	★
095	9.5-in.	★
100	10.0-in.	★
105	10.5-in.	★
110	11.0-in.	★
115	11.5-in.	★
120	12.0-in.	★
125	12.5-in.	★
130	13.0-in.	★
135	13.5-in.	★
140	14.0-in.	★
145	14.5-in.	★

**Table 1. Series 68 RTD Sensor Assemblies WITHOUT Thermowell**

★ The Standard offering represents the most common options. The starred options (★) should be selected for best delivery lead time.  
The Expanded offering is subject to additional delivery lead time.

Sensor immersion length (L)		
150	15.0-in.	★
155	15.5-in.	★
160	16.0-in.	★
165	16.5-in.	★
170	17.0-in.	★
175	17.5-in.	★
180	18.0-in.	★
185	18.5-in.	★
190	19.0-in.	★
195	19.5-in.	★
200	20.0-in.	★
205	20.5-in.	★
210	21.5-in.	★
215	21.5-in.	★
220	22.0-in.	★
225	22.5-in.	★
230	23.0-in.	★
240	24.0-in.	★
250	25.0-in.	★
260	26.0-in.	★
270	27.0-in.	★
280	28.0-in.	★
290	29.0-in.	★
300	30.0-in.	★
310	31.0-in.	★
320	32.0-in.	★
330	33.0-in.	★
340	34.0-in.	★
350	35.0-in.	★
360	36.0-in.	★
370	37.0-in.	★
380	38.0-in.	★
390	39.0-in.	★
400	40.0-in.	★
410	41.0-in.	★

**Table 1. Series 68 RTD Sensor Assemblies WITHOUT Thermowell**

★ The Standard offering represents the most common options. The starred options (★) should be selected for best delivery lead time.  
The Expanded offering is subject to additional delivery lead time.

Sensor immersion length (L)		
420	42.0-in.	★
430	43.0-in.	★
440	44.0-in.	★
450	45.0-in.	★
460	46.0-in.	★
470	47.0-in.	★
480	48.0-in.	★

### Options (include with selected model number)

Approval options		
E1	ATEX Flameproof Approval (see <a href="#">Figure 32</a> )	★
E2	Ex d- CEPEL Flameproof Approval- Brazil	★
E5	FM Explosion-proof Approval (see <a href="#">Figure 30</a> )	★
E6	CSA Explosion-proof Approval (see <a href="#">Figure 31</a> )	★
E7	IECEx Flameproof Approval	★
KF	ATEX + CSA Explosion-proof Combination Approval	★
EM	Technical Regulations Customs Union (EAC) Flameproof	★
Callendar-Van Dusen constants		
V1-V7	Callendar Van Dusen Constant (V4 not available with series 68 sensors)	★
Calibration schedule		
X8	Customer-Specified Temperature Range Calibration	★
X9	Customer-Specified Single Temperature Point Calibration	★
Calibration certification		
Q4	Calibration Certification, Customer-Specified Temperature	★
Mounting adapters		
M5-M7	Mounting adapter: Sensor Compression Fitting: M5= 1/8 - 27 NPT, M6 = 1/4 - 18 NPT, M7 = 1/2 - 14 NPT	★
A Leadkit		
A1-A8	Twisted Lead Wire Extension: A1 = 1.5 ft, A2 = 3.0 ft, A3 = 6.0 ft, A4 = 12 ft, A5 = 24 ft, A6 = 50 ft, A7 = 75 ft, A8 = 100 ft	★
B Leadkit		
B1-B8	Shielded Cable Lead Wire Extension: B1 = 1.5 ft, B2 = 3.0 ft, B3 = 6.0 ft, B4 = 12 ft, B5 = 24 ft, B6 = 50 ft, B7 = 75 ft, B8 = 100 ft	★
C Leadkit		
C1-C8 <sup>(7)</sup>	Armored Cable Lead Wire Extension: C1 = 1.5 ft, C2 = 3.0 ft, C3 = 6.0 ft, C4 = 12 ft, C5 = 24 ft, C6 = 50 ft, C7 = 75 ft, C8 = 100 ft	★

**Table 1. Series 68 RTD Sensor Assemblies WITHOUT Thermowell**

★ The Standard offering represents the most common options. The starred options (★) should be selected for best delivery lead time.

The Expanded offering is subject to additional delivery lead time.

<b>D Leadkit</b>		
D1-D8 <sup>(8)</sup>	Armored Cable Lead Wire Extensions With Electrical Plug: D1 = 1.5 ft, D2 = 3.0 ft, D3 = 6.0 ft, D4 = 12 ft, D5 = 24 ft, D6 = 50 ft, D7 = 75 ft, D8 = 100 ft	★
L1-L8 <sup>(8)</sup>	Armored Cable Mating Plugs With Lead Wire Extension: L1 = 1.5 ft, L2 = 3.0 ft, L3 = 6.0 ft, L4 = 12 ft, L5 = 24 ft, L6 = 50 ft, L7 = 75 ft, L8 = 100 ft	★
<b>J Leadkit</b>		
J1 <sup>(7)</sup>	Moisture-proof Seal Assembly For Armored Cables	★
<b>Assemble to options</b>		
XA <sup>(9)</sup>	Assemble Connection Head or Transmitter to a Sensor Assembly	★

- (1) Capsule style available in 1-in. increments only, starting at 1-in.
- (2) This option can only be used with Sensor Lead Wire Termination code N and is not available with assembly code XA or with Approval Options.
- (3) General-purpose sensors are only available in (L) lengths of 2.5-in. or greater.
- (4) Not available with Sensor Lead Wire Termination codes R, P, or C or with Approval Options.
- (5) Codes A and C must be used with an Extension Length.
- (6) 1-in. length without extension is only available in Capsule Style.
- (7) These options are only available with Sensor Lead Wire Termination codes T, L, or N.
- (8) These options are only available with Sensor Lead Wire Termination code N.
- (9) If ordering option code XA with a transmitter, specify the same option on the transmitter model code.

**Table 2. Ordering Example**

Typical Model Number	Model	Lead wire termination	Sensor type	Extension type	Extension length	Thermowell material	Sensor length	Additional options
	0068	N	11	N	00	N	045	E5



Specification and selection of product materials, options, or components must be made by the purchaser of the equipment. See [page 69](#) for more information on Material Selection.

**Table 3. Series 68 RTD Sensor Assemblies WITH Thermowell**

★ The Standard offering represents the most common options. The starred options (★) should be selected for best delivery lead time. The Expanded offering is subject to additional delivery lead time.

Model	Product description	
0068	Platinum Temperature Sensors with Thermowell	
<b>Connection head</b>		
R	Aluminum Connection Head, Six Terminals, Flat Cover, Unpainted	★
T	Aluminum Connection Head, Six Terminals, Extended Cover, Unpainted	★
P	Aluminum Connection Head, Six Terminals, Flat Cover, Painted	★
L	Aluminum Connection Head, Six Terminals, Extended Cover, Painted	★
N	Sensor Only with 6-in. PTFE-insulated, 24-gauge Lead Wires	★
D	Rosemount Aluminum Connection Head with 1/2-in. Entries	★
C	Polypropylene Connection Head	
G	Rosemount SST Connection Head with 1/2-in. Entries	
<b>Sensor type (single element -50 to 400 °C [-58 to 752 °F])</b>		
11	General-purpose Style	★
21	Spring-loaded Style	★
31 <sup>(1)</sup>	Bayonet Spring-loaded Style (available in (X) lengths of 1 to 21-in., increments of 1-in.)	
<b>Extension type</b>		
A <sup>(2)</sup>	Nipple Coupling	★
C <sup>(2)</sup>	Nipple Union	★
N	None (use with Extension Length Option Code 00)	★
<b>Extension length (E)</b>		
00	0.0 in.	★
30	3.0 in.	★
60	6.0 in.	★
<b>Thermowell material</b>		
A	316 SST	★
B	304 SST	★
C	Carbon Steel	★
D	316L SST	★
E	304L SST	★
F	Alloy 20	
G	Alloy 400	
H	Alloy 600	
J	Alloy C-276	
L	Alloy B	

**Table 3. Series 68 RTD Sensor Assemblies WITH Thermowell**

★ The Standard offering represents the most common options. The starred options (★) should be selected for best delivery lead time.

The Expanded offering is subject to additional delivery lead time.

Thermowell material			
M	304 SST with PTFE coating		
P	Chrome Molybdenum Grade F22		
R	Nickel 200		
T	Titanium		
U <sup>(3)</sup>	316 SST with Tantalum Sheath		
V	310 SST		
W	321 SST		
Z	Chrome Molybdenum Grade F11		
Immersion length (U)	Thermowell length (L) <sup>(4)</sup>	Lagging length (T) <sup>(5)</sup>	
015 <sup>(6)</sup>	1.5-in.	4.0-in.	1.0-in. ★
020 <sup>(6)</sup>	2.0-in.	4.0-in.	0.5-in. ★
025 <sup>(6)</sup>	2.5-in.	4.0-in.	0.0-in. ★
030	3.0-in.	6.0-in.	1.5-in. ★
035	3.5-in.	6.0-in.	1.0-in. ★
040	4.0-in.	6.0-in.	0.5-in. ★
045	4.5-in.	6.0-in.	0.0-in. ★
050	5.0-in.	9.0-in.	2.5-in. ★
055	5.5-in.	9.0-in.	2.0-in. ★
060	6.0-in.	9.0-in.	1.5-in. ★
065	6.5-in.	9.0-in.	1.0-in. ★
070	7.0-in.	9.0-in.	0.5-in. ★
075	7.5-in.	9.0-in.	0.0-in. ★
080	8.0-in.	12.0-in.	2.5-in. ★
085	8.5-in.	12.0-in.	2.0-in. ★
090	9.0-in.	12.0-in.	1.5-in. ★
095	9.5-in.	12.0-in.	1.0-in. ★
100	10.0-in.	12.0-in.	0.5-in. ★
105	10.5-in.	12.0-in.	0.0-in. ★
110	11.0-in.	15.0-in.	2.5-in. ★
115	11.5-in.	15.0-in.	2.0-in. ★
120	12.0-in.	15.0-in.	1.5-in. ★
125	12.5-in.	15.0-in.	1.0-in. ★
130	13.0-in.	15.0-in.	0.5-in. ★
135	13.5-in.	15.0-in.	0.0-in. ★
140	14.0-in.	18.0-in.	2.5-in. ★
145	14.5-in.	18.0-in.	2.0-in. ★

**Table 3. Series 68 RTD Sensor Assemblies WITH Thermowell**

★ The Standard offering represents the most common options. The starred options (★) should be selected for best delivery lead time.  
The Expanded offering is subject to additional delivery lead time.

Immersion length (U)		Thermowell length (L) <sup>(4)</sup>	Lagging length (T) <sup>(5)</sup>	
150	15.0-in.	18.0-in.	1.5-in.	★
155	15.5-in.	18.0-in.	1.0-in.	★
160	16.0-in.	18.0-in.	0.5-in.	★
165	16.5-in.	18.0-in.	0.0-in.	★
170	17.0-in.	21.0-in.	2.5-in.	★
175	17.5-in.	21.0-in.	2.0-in.	★
180	18.0-in.	21.0-in.	1.5-in.	★
185	18.5-in.	21.0-in.	1.0-in.	★
190	19.0-in.	21.0-in.	0.5-in.	★
195	19.5-in.	21.0-in.	0.0-in.	★
200	20.0-in.	24.0-in.	2.5-in.	★
205	20.5-in.	24.0-in.	2.0-in.	★
210	21.0-in.	24.0-in.	1.5-in.	★
215	21.5-in.	24.0-in.	1.0-in.	★
220	22.0-in.	24.0-in.	0.5-in.	★
225	22.5-in.	24.0-in.	0.0-in.	★
230	23.0-in.	27.0-in.	2.5-in.	★
240	24.0-in.	27.0-in.	1.5-in.	★
250	25.0-in.	27.0-in.	0.5-in.	★
260	26.0-in.	30.0-in.	2.5-in.	★
270	27.0-in.	30.0-in.	1.5-in.	★
280	28.0-in.	30.0-in.	0.5-in.	★
290	29.0-in.	33.0-in.	2.5-in.	★
300	30.0-in.	33.0-in.	1.5-in.	★
310	31.0-in.	33.0-in.	0.5-in.	★
320	32.0-in.	36.0-in.	2.5-in.	★
330	33.0-in.	36.0-in.	1.5-in.	★
340	34.0-in.	36.0-in.	0.5-in.	★
350	35.0-in.	39.0-in.	2.5-in.	★
360	36.0-in.	39.0-in.	1.5-in.	★
370	37.0-in.	39.0-in.	0.5-in.	★
380	38.0-in.	42.0-in.	2.5-in.	★
390	39.0-in.	42.0-in.	1.5-in.	★
400	40.0-in.	42.0-in.	0.5-in.	★
410	41.0-in.	45.0-in.	2.5-in.	★
420	42.0-in.	45.0-in.	1.5-in.	★
430	43.0-in.	45.0-in.	0.5-in.	★

**Table 3. Series 68 RTD Sensor Assemblies WITH Thermowell**

★ The Standard offering represents the most common options. The starred options (★) should be selected for best delivery lead time.

The Expanded offering is subject to additional delivery lead time.

Immersion length (U)		Thermowell length (L) <sup>(4)</sup>	Lagging length (T) <sup>(5)</sup>	
440	44.0-in.	48.0-in.	2.5-in.	★
450	45.0-in.	48.0-in.	1.5-in.	★
460	46.0-in.	48.0-in.	0.5-in.	★
470	47.0-in.	51.0-in.	2.5-in.	★
480	48.0-in.	51.0-in.	1.5-in.	★
Thermowell style		Mounting	Stem	
T20	Threaded	1/2-14 ANPT	Stepped	★
T22	Threaded	3/4-14 ANPT	Stepped	★
T24	Threaded	1-11.5 ANPT	Stepped	★
T26	Threaded	3/4-14 ANPT	Tapered	★
T28	Threaded	1-11.5 ANPT	Tapered	★
T30	Threaded	1 1/2-11 ANPT	Tapered	★
T32	Threaded	1/2-14 ANPT	Straight	★
T34	Threaded	3/4-14 ANPT	Straight	★
T36	Threaded	1-11.5 ANPT	Straight	★
T38	Threaded	3/4-14 ANPT	Straight	★
T44	Threaded	1/2-14 ANPT	Tapered	★
W38	Welded	3/4-in. pipe	Stepped	★
W40	Welded	1-in. pipe	Stepped	★
W42	Welded	3/4-in. pipe	Tapered	★
W44	Welded	1-in. pipe	Tapered	★
W46	Welded	1 1/4-in. pipe	Tapered	★
W48	Welded	3/4-in. pipe	Straight	★
W50	Welded	1-in. pipe	Straight	★
F10	Flanged	2-in., Class 150	Straight	★
F12	Flanged	3-in., Class 150	Straight	★
F52 <sup>(7)</sup>	Flanged	1-in., Class 150	Stepped	★
F54	Flanged	1 1/2-in., Class 150	Stepped	★
F56	Flanged	2-in., Class 150	Stepped	★
F58 <sup>(8)</sup>	Flanged	1-in., Class 150	Tapered	★
F60	Flanged	1 1/2-in., Class 150	Tapered	★
F62	Flanged	2-in. Class 150	Tapered	★
F64 <sup>(7)</sup>	Flanged	1-in., Class 150	Straight	★
F66	Flanged	1 1/2-in., Class 150	Straight	★
F70 <sup>(7)</sup>	Flanged	1-in., Class 300	Stepped	★
F72	Flanged	1 1/2-in., Class 300	Stepped	★
F74	Flanged	2-in., Class 300	Stepped	★

**Table 3. Series 68 RTD Sensor Assemblies WITH Thermowell**

★ The Standard offering represents the most common options. The starred options (★) should be selected for best delivery lead time. The Expanded offering is subject to additional delivery lead time.

Thermowell style		Mounting	Stem	
F76 <sup>(8)</sup>	Flanged	1-in., Class 300	Tapered	★
F78	Flanged	1½-in., Class 300	Tapered	★
F80	Flanged	2-in., Class 300	Tapered	★
F82 <sup>(7)</sup>	Flanged	1-in., Class 300	Straight	★
F84	Flanged	1½-in., Class 300	Straight	★
F86	Flanged	2-in., Class 300	Straight	★
F88 <sup>(7)</sup>	Flanged	1-in., Class 600	Stepped	★
F90 <sup>(9)</sup>	Flanged	1½-in., Class 600	Stepped	★
F92 <sup>(9)</sup>	Flanged	2-in., Class 600	Stepped	★
F94 <sup>(8)(9)</sup>	Flanged	1-in., Class 600	Tapered	★
F96 <sup>(9)</sup>	Flanged	1½-in., Class 600	Tapered	★
F98 <sup>(9)</sup>	Flanged	2-in., Class 600	Tapered	★
F02 <sup>(7)(9)</sup>	Flanged	1-in., Class 600	Straight	★
F04 <sup>(9)</sup>	Flanged	1½-in., Class 600	Straight	★
F06 <sup>(9)</sup>	Flanged	2-in., Class 600	Straight	★
F16 <sup>(9)</sup>	Flanged	1½-in., Class 900	Tapered	★
F34 <sup>(9)</sup>	Flanged	1½-in., Class 1500	Tapered	★
F24 <sup>(9)</sup>	Flanged	2-in., Class 1500	Tapered	★
F08 <sup>(10)</sup>	Flanged	1½-in., Class 2500	Tapered	★
Q02 <sup>(11)</sup>	Sanitary, Tri-Clamp™	1-in., Tri-Clamp	Stepped	★
Q04 <sup>(11)</sup>	Sanitary, Tri-Clamp	1½-in., Tri-Clamp	Stepped	★
Q06 <sup>(11)</sup>	Sanitary, Tri-Clamp	2-in., Tri-Clamp	Stepped	★
Q08 <sup>(11)</sup>	Sanitary, Tri-Clamp	3-in., Tri-Clamp	Stepped	★
Q20 <sup>(11)</sup>	Sanitary, Tri-Clamp	¾-in., Tri-Clamp	Straight	★
Q22 <sup>(11)</sup>	Sanitary, Tri-Clamp	1-in., Tri-Clamp	Straight	★
Q24 <sup>(11)</sup>	Sanitary, Tri-Clamp	1½-in., Tri-Clamp	Straight	★
Q26 <sup>(11)</sup>	Sanitary, Tri-Clamp	2-in., Tri-Clamp	Straight	★
Q28 <sup>(11)</sup>	Sanitary, Tri-Clamp	3-in., Tri-Clamp	Straight	★

### Options (include with selected model number)

Product certifications		
E1	ATEX Flameproof approval (see <a href="#">Figure 32</a> )	★
E2	Ex d- CEPEL Flameproof Approval- Brazil	★
E5	FM Explosion-proof approval (see <a href="#">Figure 30</a> )	★
E6	CSA Explosion-proof approval (see <a href="#">Figure 31</a> )	★
E7	IECEx Flameproof approval	★

**Table 3. Series 68 RTD Sensor Assemblies WITH Thermowell**

★ The Standard offering represents the most common options. The starred options (★) should be selected for best delivery lead time.  
The Expanded offering is subject to additional delivery lead time.

<b>Product certifications</b>		
KF	ATEX + CSA Explosion-proof Combination Approval	★
EM	Technical Regulations Customs Union (EAC) Flameproof	★
<b>Callendar-Van Dusen Constants</b>		
V1-V7	Callendar-van Dusen Constants (V4 not available with series 68 sensors)	★
<b>Calibration schedule</b>		
X8	Customer-Specified Temperature Calibration	★
X9	Customer-Specified Single Temperature Point Calibration	★
Q4	Calibration Certification, Customer-Specified Temperature	★
<b>A Leadkit</b>		
A1-A8	Twisted Lead Wire Extension: A1 = 1.5 ft, A2 = 3.0 ft, A3 = 6.0 ft, A4 = 12 ft, A5 = 24 ft, A6 = 50 ft, A7 = 75 ft, A8 = 100 ft	★
<b>B Leadkit</b>		
B1-B8	Shielded Cable Lead Wire Extension: B1 = 1.5 ft, B2 = 3.0 ft, B3 = 6.0 ft, B4 = 12 ft, B5 = 24 ft, B6 = 50 ft, B7 = 75 ft, B8 = 100 ft	★
<b>C Leadkit</b>		
C1-C8 <sup>(12)</sup>	Armored Cable Lead Wire Extension: C1 = 1.5 ft, C2 = 3.0 ft, C3 = 6.0 ft, C4 = 12 ft, C5 = 24 ft, C6 = 50 ft, C7 = 75 ft, C8 = 100 ft	★
<b>D Leadkit</b>		
D1-D8 <sup>(13)</sup>	Armored Cable Lead Wire Extensions with Electrical Plug: D1 = 1.5 ft, D2 = 3.0 ft, D3 = 6.0 ft, D4 = 12 ft, D5 = 24 ft, D6 = 50 ft, D7 = 75 ft, D8 = 100 ft	★
<b>L Leadkit</b>		
L1-L8 <sup>(13)</sup>	Armored Cable Mating Plugs with Lead Wire Extension: L1 = 1.5 ft, L2 = 3.0 ft, L3 = 6.0 ft, L4 = 12 ft, L5 = 24 ft, L6 = 50 ft, L7 = 75 ft, L8 = 100 ft	★
<b>J Leadkit</b>		
J1 <sup>(12)</sup>	Moisture-Proof Seal Assembly for Armored Cables	★
<b>Special external pressure test</b>		
R01	Special External Pressure Test	★
<b>Material certification</b>		
Q8	Material Certification	★
<b>Surface finish certification</b>		
Q16	Surface Finish Certification	★
<b>Dye penetration test</b>		
R03	Dye Penetration Test	★
<b>NACE Approval</b>		
R05	NACE Approval	★

**Table 3. Series 68 RTD Sensor Assemblies WITH Thermowell**

★ The Standard offering represents the most common options. The starred options (★) should be selected for best delivery lead time.  
The Expanded offering is subject to additional delivery lead time.

<b>SST plug and chain</b>		
R06	Stainless Steel Plug and Chain	★
<b>Full penetration weld</b>		
R07 <sup>(14)</sup>	Full Penetration Weld	★
<b>Flange face options</b>		
R09 <sup>(14)(15)</sup>	Concentric serrations of thermowell flange face	★
<b>Flat faced flange</b>		
R10 <sup>(14)(15)</sup>	Flat Faced Flange	★
<b>Vent hole</b>		
R11	Vent Hole	★
<b>Thermowell X-ray</b>		
R12	Thermowell Xray	★
<b>Special surface finish</b>		
R14	Special Surface Finish (12 Ra) (Maximum “U” length = 22.5-in.)	★
<b>Ring joint flange</b>		
R16 <sup>(14)(15)</sup>	Ring Joint Flange (not available with 0-in. [T] length)	★
<b>Electropolish</b>		
R20 <sup>(16)</sup>	Electropolish	★
<b>Wake frequency</b>		
R21	Wake Frequency-Thermowell Strength Calculation	★
<b>Internal pressure test</b>		
R22	Internal Pressure Test	★
<b>Brass plug and chain</b>		
R23	Brass plug and chain	★
<b>Canadian registration no.</b>		
R24	CRN Marking for British Columbia	
R25	CRN Marking for Alberta	
R26	CRN Marking for Saskatchewan	
R27	CRN Marking for Manitoba	
R28	CRN Marking for Ontario	
R29	CRN Marking for Quebec	
R30	CRN Marking for New Brunswick	
R31	CRN Marking for Nova Scotia	
R32	CRN Marking for Prince Edward Island	

**Table 3. Series 68 RTD Sensor Assemblies WITH Thermowell**

★ The Standard offering represents the most common options. The starred options (★) should be selected for best delivery lead time.

The Expanded offering is subject to additional delivery lead time.

Canadian registration no.		
R33	CRN Marking for Yukon Territory	
R34	CRN Marking for Northwest Territory	
R35	CRN Marking for Nunavut	
R36	CRN Marking for Newfoundland and Labrador	
Twell from hex stock		
R37	Thermowell from Hex Stock	
Assemble to options		
XA <sup>(17)</sup>	Assemble Connection Head or Transmitter to a Sensor Assembly	★

- (1) Not available with Sensor Lead Wire Termination codes R, P, or C or with Approval Options.
- (2) Codes A and C must be used with an Extension Length.
- (3) Available only with straight stem flanged thermowells.
- (4) Thermowells with an overall length ("U" + "T" + 1.75-in.) of 36-in. or less are machined from solid barstock. Thermowells with an overall length larger than 42-in. will be constructed using a welded 3-piece design and are available only with a stepped stem style. For lengths between 36-in. and 42-in consult factory for construction method.
- (5) For additional (T) lengths, see [Table 18](#) (Thermowell lagging length (T) section).
- (6) Available only with straight or tapered stem thermowells.
- (7) F52, F64, F70, F88, and F02 are not compatible with 1-in. Sch. XXs pipe.
- (8) F58, F76, and F94 may not be compatible with 1-in. Sch. pipe and are not compatible with 1-in. Sch. 80, 160 or XXS pipe.
- (9) These options cannot be used with 0-in. (T) length.
- (10) F08 cannot be used with 0- or 1.2-in. (T) length.
- (11) Limited to 24-in. immersion length and 316 or 304 SST materials only.
- (12) These options are only available with Sensor Lead Wire Termination codes T, L or N.
- (13) These options are only available with Sensor Lead Wire Termination code N.
- (14) Available on flanged thermowells only.
- (15) Only one flange face option allowed.
- (16) Not available on flanged thermowells and L lengths longer than 24-in.
- (17) If ordering option code XA with a transmitter, specify the same option on the transmitter model code.

**Table 4. Ordering Example**

Typical Model Number	Model	Lead wire termination	Sensor type	Extension type	Extension length	Material code	Immersion length	Mounting style	Additional options
	0068	N	21	A	30	A	075	T22	E5



## Rosemount 78 Sensor and Thermowell



The Rosemount 78 Sensor and Thermowell have designs that provide flexible and reliable temperature measurements in process environments.

Features include:

- Industry-standard Pt-100 RTD
- Single Element High Temperature RTD or Dual Element RTD
- Variety of enclosure and connection head options
- Global hazardous-location approvals (Option Codes E5, E6, E7)
- Calibration services to give you insight to sensor performance (Option Codes V1-V8, X8, X9)
- Calibration certification documentation to accompany sensor (Option Code Q4)
- Assemble to Transmitter option (Option Code XA)

**Table 5. Series 78 RTD Sensor Assemblies WITHOUT Thermowell**

★ The Standard offering represents the most common options. The starred options (★) should be selected for best delivery lead time. The Expanded offering is subject to additional delivery lead time.

Model	Product description		
0078	Platinum Temperature Sensor without Thermowell		
<b>Connection head</b>			
R	Aluminum Connection Head, Six Terminals, Flat Cover, Unpainted		★
T	Aluminum Connection Head, Six Terminals, Extended Cover, Unpainted		★
P	Aluminum Connection Head, Six Terminals, Flat Cover, Painted		★
L	Aluminum Connection Head, Six Terminals, Extended Cover, Painted		★
N	Sensor only with 6-in. PTFE-insulated, 22-gauge lead wires		★
D	Rosemount Aluminum Connection head		★
C	Polypropylene Connection Head		
G	Rosemount SST Connection Head with 1/2 in. Entries		
<b>Sensor type</b>			<b>Temperature range</b>
<b>Single element temperature sensors</b>			<b>-200 to 500 °C (-328 to 932 °F)</b>
01 <sup>(1)(2)</sup>	Capsule Style		★
11 <sup>(3)</sup>	General-purpose Style		★
21	Spring-loaded Style		★
31 <sup>(4)</sup>	Bayonet Spring-loaded Style (available in [X] lengths of 1 to 21-in, increments of 1-in.)		
<b>Single element high temperature sensors</b>			<b>0 to 600 °C (32 to 1112 °F)</b>
03 <sup>(2)</sup>	Capsule Style (available in [X] lengths of 3 to 24-in, increments of 1-in.)		★
13 <sup>(3)</sup>	General-purpose Style (available in [X] lengths of 3 to 24-in, increments of 1/2-in.)		★
23	Spring-loaded style (available in [X] lengths of 3 to 24-in, increments of 1/2-in.)		★
33 <sup>(4)</sup>	Bayonet spring-loaded style (available in [X] lengths of 3 to 21-in, increments of 1-in.)		

**Table 5. Series 78 RTD Sensor Assemblies WITHOUT Thermowell**

★ The Standard offering represents the most common options. The starred options (★) should be selected for best delivery lead time.

The Expanded offering is subject to additional delivery lead time.

Sensor type		Temperature range	
<b>Dual-element temperature sensors</b>		<b>-200 to 500 °C (-328 to 932 °F)</b>	
05 <sup>(2)</sup>	Capsule Style		★
15 <sup>(3)</sup>	General-purpose Style		★
25	Spring-loaded Style		★
35 <sup>(4)</sup>	Bayonet Spring-loaded Style (available in [X] lengths of 1 to 21-in, increments of 1-in.)		
Extension type		Extension type material	
A <sup>(5)</sup>	Nipple Coupling	300 series SST	★
C <sup>(5)</sup>	Nipple Union	300 series SST	★
N	None (use with Extension Length Option code 00)		★
Extension length (E)			
00	0.0 in.		★
30	3.0 in.		★
60	6.0 in.		★
Thermowell material			
N	No Thermowell Required		★
Sensor immersion length (L)			
010 <sup>(6)</sup>	1.0-in.		★
015	1.5-in.		★
020	2.0-in.		★
025	2.5-in.		★
030	3.0-in.		★
035	3.5-in.		★
040	4.0-in.		★
045	4.5-in.		★
050	5.0-in.		★
055	5.5-in.		★
060	6.0-in.		★
065	6.5-in.		★
070	7.0-in.		★
075	7.5-in.		★
080	8.0-in.		★
085	8.5-in.		★
090	9.0-in.		★
095	9.5-in.		★
100	10.0-in.		★

**Table 5. Series 78 RTD Sensor Assemblies WITHOUT Thermowell**

★ The Standard offering represents the most common options. The starred options (★) should be selected for best delivery lead time.  
 The Expanded offering is subject to additional delivery lead time.

Sensor immersion length (L)		
105	10.5-in.	★
110	11.0-in.	★
115	11.5-in.	★
120	12.0-in.	★
125	12.5-in.	★
130	13.0-in.	★
135	13.5-in.	★
140	14.0-in.	★
145	14.5-in.	★
150	15.0-in.	★
155	15.5-in.	★
160	16.0-in.	★
165	16.5-in.	★
170	17.0-in.	★
175	17.5-in.	★
180	18.0-in.	★
185	18.5-in.	★
190	19.0-in.	★
195	19.5-in.	★
200	20.0-in.	★
205	20.5-in.	★
210	21.0-in.	★
215	21.5-in.	★
220	22.0-in.	★
225	22.5-in.	★
230	23.0-in.	★
235	23.5-in.	★
240	24.0-in.	★
245	24.5-in.	★
250	25.0-in.	★
260	26.0-in.	★
270	27.0-in.	★
280	28.0-in.	★
290	29.0-in.	★
300	30.0-in.	★
310	31.0-in.	★
320	32.0-in.	★

**Table 5. Series 78 RTD Sensor Assemblies WITHOUT Thermowell**

★ The Standard offering represents the most common options. The starred options (★) should be selected for best delivery lead time.  
The Expanded offering is subject to additional delivery lead time.

Sensor immersion length (L)		
330	33.0-in.	★
340	34.0-in.	★
350	35.0-in.	★
360	36.0-in.	★
370	37.0-in.	★
380	38.0-in.	★
390	39.0-in.	★
400	40.0-in.	★
410	41.0-in.	★
420	42.0-in.	★
430	43.0-in.	★
440	44.0-in.	★
450	45.0-in.	★
460	46.0-in.	★
470	47.0-in.	★
480 <sup>(7)</sup>	48.0-in.	★

**Options (include with selected model number)**

Sensor		
A <sup>(8)</sup>	IEC 751 Class A Sensor (-200 to 500 °C)	
Approval options		
E1	ATEX Flameproof approval (see <a href="#">Figure 32</a> )	★
E2	Ex d- CEPEL Flameproof Approval- Brazil	★
E5	FM Explosion-proof approval (see <a href="#">Figure 30</a> )	★
E6	CSA Explosion-proof approval (see <a href="#">Figure 31</a> )	★
E7	IECEX Flameproof approval	★
KF	ATEX + CSA Explosion-proof Combination Approval	★
EM	Technical Regulations Customs Union (EAC) Flameproof	★
Callendar-Van Dusen constants		
V1-V7	Callendar-Van Dusen Constants	★
Calibration schedule		
X8	Customer-Specified Temperature Range Calibration	★
X9	Customer-Specified Single Temperature Point Calibration	★
Calibration certification		
Q4	Calibration Certification, Customer-Specified Temperature	★

**Table 5. Series 78 RTD Sensor Assemblies WITHOUT Thermowell**

★ The Standard offering represents the most common options. The starred options (★) should be selected for best delivery lead time.

The Expanded offering is subject to additional delivery lead time.

<b>Mounting adapters</b>		
M5-M7	Mounting Adapter; Sensor Compression Fitting: M5= 1/8-27 NPT, M6 = 1/4-18 NPT, M7 = 1/2-14 NPT	★
<b>A Leadkit</b>		
A1-A8	Twisted lead wire extension: A1 = 1.5 ft, A2 = 3.0 ft, A3 = 6.0 ft, A4 = 12 ft, A5 = 24 ft, A6 = 50 ft, A7 = 75 ft, A8 = 100 ft	★
<b>B Leadkit</b>		
B1-B8	Shielded cable lead wire extension: B1 = 1.5 ft, B2 = 3.0 ft, B3 = 6.0 ft, B4 = 12 ft, B5 = 24 ft, B6 = 50 ft, B7 = 75 ft, B8 = 100 ft	★
<b>C Leadkit</b>		
C1-C8 <sup>(9)</sup>	Armored cable lead wire extension: C1 = 1.5 ft, C2 = 3.0 ft, C3 = 6.0 ft, C4 = 12 ft, C5 = 24 ft, C6 = 50 ft, C7 = 75 ft, C8 = 100 ft	★
<b>D Leadkit</b>		
D1-D <sup>(10)</sup>	Armored cable lead wire extensions with electrical plug: D1 = 1.5 ft, D2 = 3.0 ft, D3 = 6.0 ft, D4 = 12 ft, D5 = 24 ft, D6 = 50 ft, D7 = 75 ft, D8 = 100 ft	★
<b>L Leadkit</b>		
L1-L8 <sup>(10)</sup>	Armored cable mating plugs with lead wire extension: L1 = 1.5 ft, L2 = 3.0 ft, L3 = 6.0 ft, L4 = 12 ft, L5 = 24 ft, L6 = 50 ft, L7 = 75 ft, L8 = 100 ft	★
<b>J Leadkit</b>		
J1 <sup>(9)</sup>	Moisture-proof seal assembly for armored cables	★
<b>Assemble to options</b>		
XA <sup>(11)</sup>	Assemble connection head or transmitter to a sensor assembly (PTFE paste where appropriate, fully wired.)	★

(1) Capsule style available in 1-in. increments only, starting at 1-in.

(2) This option can only be used with Sensor Lead Wire Termination code N and is not available with assembly option XA or with Approval Options.

(3) General-purpose sensors are available in (L) lengths of 2.5-in. or greater.

(4) Not available with Sensor Lead Wire Termination codes R, P, or C or Approval Options.

(5) Codes A and C must be used with an extension length.

(6) 1-in. length without extension is only available in Capsule Style.

(7) Additional lengths are available up to 68-in., increments of 1-in.

(8) The IEC 751 Class A option is not available with high-temperature sensors.

(9) These options are only available with Sensor Leadwire Termination Codes T, L, or N.

(10) These options are only available with Sensor Leadwire Termination code N.

(11) If ordering option code XA with a transmitter, specify the same option on the transmitter model code.

**Table 6. Ordering Example**

Typical Model Number	Model	Connection head	Sensor type	Extension type	Extension length	Thermowell material	Immersion length	Additional options
	0078	N	21	N	00	N	045	E5

**Table 7. Series 78 RTD Sensor Assemblies WITH Thermowell**

★ The Standard offering represents the most common options. The starred options (★) should be selected for best delivery lead time.  
The Expanded offering is subject to additional delivery lead time.

Model	Product description	
0078	Platinum Temperature Sensor with Thermowell	
<b>Connection head</b>		
R	Aluminum Connection Head, Six Terminals, Flat Cover, Unpainted	★
T	Aluminum Connection Head, Six Terminals, Extended Cover, Unpainted	★
P	Aluminum Connection Head, Six Terminals, Flat Cover, Painted	★
L	Aluminum Connection Head, Six Terminals, Extended Cover, Painted	★
N	Sensor Only with 6-in. PTFE-insulated, 24-gauge Lead Wires	★
D	Rosemount Aluminum Connection Head with 1/2-in. Entries	★
C	Polypropylene Connection Head	
G	Rosemount SST Connection Head with 1/2-in. Entries	
<b>Sensor type</b>		<b>Temperature range</b>
<b>Single Element Temperature Sensors</b>		<b>-200 to 500 °C (-328 to 932 °F)</b>
11	General-purpose Style	★
21	Spring-loaded Style	★
31 <sup>(1)</sup>	Bayonet Spring-loaded Style (available in [X] lengths of 1 to 21-in., increments of 1-in.)	
<b>Single element high temperature sensors</b>		<b>0 to 600 °C (32 to 1112 °F)</b>
13	General-purpose Style (available in [X] lengths of 3 to 24-in., increments of 1/2-in.)	★
23	Spring-loaded Style (available in [X] lengths of 3 to 24-in., increments of 1/2-in.)	★
33 <sup>(1)</sup>	Bayonet Spring-loaded Style (available in [X] lengths of 3 to 21-in., increments of 1-in.)	
<b>Dual-element temperature sensors</b>		<b>-200 to 500 °C (-328 to 932 °F)</b>
15	General-purpose Style	★
25	Spring-loaded Style	★
35 <sup>(1)</sup>	Bayonet Spring-loaded Style (available in [X] lengths of 1 to 21-in., increments of 1-in.)	
<b>Extension type</b>		<b>Extension type material</b>
A <sup>(2)</sup>	Nipple Coupling	300 series SST
C <sup>(2)</sup>	Nipple Union	300 series SST
N	None (use with extension length option code 00)	None
<b>Extension length (E)</b>		
00	0.0 in.	★
30	3.0 in.	★
60	6.0 in.	★
<b>Thermowell material</b>		
A	316 SST	★
B	304 SST	★

**Table 7. Series 78 RTD Sensor Assemblies WITH Thermowell**

★ The Standard offering represents the most common options. The starred options (★) should be selected for best delivery lead time.  
The Expanded offering is subject to additional delivery lead time.

Thermowell material				
C	Carbon Steel			★
D	316L SST			★
E	304L SST			★
F	Alloy 20			
G	Alloy 400			
H	Alloy 600			
J	Alloy C-276			
L	Alloy B			
M	304 SST with PTFE coating			
P	Chrome Molybdenum Grade F22			
R	Nickel 200			
T	Titanium			
U <sup>(3)</sup>	316 SST with Tantalum Sheath			
V	310 SST			
W	321 SST			
Z	Chrome Molybdenum Grade F11			
Immersion length (U) <sup>(4)</sup>		Thermowell length (L)	Lagging length (T) <sup>(5)</sup>	
015 <sup>(6)</sup>	1.5-in.	4.0-in.	1.0-in.	★
020 <sup>(6)</sup>	2.0-in.	4.0-in.	0.5-in.	★
025 <sup>(6)</sup>	2.5-in.	4.0-in.	0.0-in.	★
030	3.0-in.	6.0-in.	1.5-in.	★
035	3.5-in.	6.0-in.	1.0-in.	★
040	4.0-in.	6.0-in.	0.5-in.	★
045	4.5-in.	6.0-in.	0.0-in.	★
050	5.0-in.	9.0-in.	2.5-in.	★
055	5.5-in.	9.0-in.	2.0-in.	★
060	6.0-in.	9.0-in.	1.5-in.	★
065	6.5-in.	9.0-in.	1.0-in.	★
070	7.0-in.	9.0-in.	0.5-in.	★
075	7.5-in.	9.0-in.	0.0-in.	★
080	8.0-in.	12.0-in.	2.5-in.	★
085	8.5-in.	12.0-in.	2.0-in.	★
090	9.0-in.	12.0-in.	1.5-in.	★
095	9.5-in.	12.0-in.	1.0-in.	★
100	10.0-in.	12.0-in.	0.5-in.	★
105	10.5-in.	12.0-in.	0.0-in.	★

**Table 7. Series 78 RTD Sensor Assemblies WITH Thermowell**

★ The Standard offering represents the most common options. The starred options (★) should be selected for best delivery lead time.  
The Expanded offering is subject to additional delivery lead time.

Immersion length (U) <sup>(4)</sup>		Thermowell length (L)	Lagging length (T) <sup>(5)</sup>	
110	11.0-in.	15.0-in.	2.5-in.	
115	11.5-in.	15.0-in.	2.0-in.	★
120	12.0-in.	15.0-in.	1.5-in.	★
125	12.5-in.	15.0-in.	1.0-in.	★
130	13.0-in.	15.0-in.	0.5-in.	★
135	13.5-in.	15.0-in.	0.0-in.	★
140	14.0-in.	18.0-in.	2.5-in.	★
145	14.5-in.	18.0-in.	2.0-in.	★
150	15.0-in.	18.0-in.	1.5-in.	★
155	15.5-in.	18.0-in.	1.0-in.	★
160	16.0-in.	18.0-in.	0.5-in.	★
165	16.5-in.	18.0-in.	0.0-in.	★
170	17.0-in.	21.0-in.	2.5-in.	★
175	17.5-in.	21.0-in.	2.0-in.	★
180	18.0-in.	21.0-in.	1.5-in.	★
185	18.5-in.	21.0-in.	1.0-in.	★
190	19.0-in.	21.0-in.	0.5-in.	★
195	19.5-in.	21.0-in.	0.0-in.	★
200	20.0-in.	24.0-in.	2.5-in.	★
205	20.5-in.	24.0-in.	2.0-in.	★
210	21.0-in.	24.0-in.	1.5-in.	★
215	21.5-in.	24.0-in.	1.0-in.	★
220	22.0-in.	24.0-in.	0.5-in.	★
225	22.5-in.	24.0-in.	0.0-in.	★
230	23.0-in.	27.0-in.	2.5-in.	★
240	24.0-in.	27.0-in.	1.5-in.	★
250	25.0-in.	27.0-in.	0.5-in.	★
260	26.0-in.	30.0-in.	2.5-in.	★
270	27.0-in.	30.0-in.	1.5-in.	★
280	28.0-in.	30.0-in.	0.5-in.	★
290	29.0-in.	33.0-in.	2.5-in.	★
300	30.0-in.	30.0-in.	1.5-in.	★
310	31.0-in.	30.0-in.	0.5-in.	★
320	32.0-in.	36.0-in.	2.5-in.	★
330	33.0-in.	36.0-in.	1.5-in.	★
340	34.0-in.	36.0-in.	0.5-in.	★



**Table 7. Series 78 RTD Sensor Assemblies WITH Thermowell**

★ The Standard offering represents the most common options. The starred options (★) should be selected for best delivery lead time.  
The Expanded offering is subject to additional delivery lead time.

Immersion length (U) <sup>(4)</sup>		Thermowell length (L)	Lagging length (T) <sup>(5)</sup>	
350	35.0-in.	39.0-in.	2.5-in.	★
360	36.0-in.	39.0-in.	1.5-in.	★
370	37.0-in.	39.0-in.	0.5-in.	★
380	38.0-in.	42.0-in.	2.5-in.	★
390	39.0-in.	42.0-in.	1.5-in.	★
400	40.0-in.	42.0-in.	0.5-in.	★
410	41.0-in.	45.0-in.	2.5-in.	★
420	42.0-in.	45.0-in.	1.5-in.	★
430	43.0-in.	45.0-in.	0.5-in.	★
440	44.0-in.	48.0-in.	2.5-in.	★
450	45.0-in.	48.0-in.	1.5-in.	★
460	46.0-in.	48.0-in.	0.5-in.	★
470	47.0-in.	51.0-in.	2.5-in.	★
480	48.0-in.	51.0-in.	1.5-in.	★
Thermowell style		Mounting	Stem	
T20	Threaded	1/2-14 ANPT	Stepped	★
T22	Threaded	3/4-14 ANPT	Stepped	★
T24	Threaded	1-11.5 ANPT	Stepped	★
T26	Threaded	3/4-14 ANPT	Tapered	★
T28	Threaded	1-11.5 ANPT	Tapered	★
T30	Threaded	1 1/2-11 ANPT	Tapered	★
T32	Threaded	1/2-14 ANPT	Straight	★
T34	Threaded	3/4-14 ANPT	Straight	★
T36	Threaded	1-11.5 ANPT	Straight	★
T38	Threaded	3/4-14 ANPT	Straight	★
T44	Threaded	1/2-14 ANPT	Tapered	★
W38	Welded	3/4-in. pipe	Stepped	★
W40	Welded	1-in. pipe	Stepped	★
W42	Welded	3/4-in. pipe	Tapered	★
W44	Welded	1-in. pipe	Tapered	★
W46	Welded	1 1/4-in. pipe	Tapered	★
W48	Welded	3/4-in. pipe	Straight	★
W50	Welded	1-in. pipe	Straight	★
F10	Flanged	2-in., Class 150	Straight	★
F12	Flanged	3-in., Class 150	Straight	★
F52 <sup>(7)</sup>	Flanged	1-in., Class 150	Stepped	★
F54	Flanged	1 1/2-in., Class 150	Stepped	★

**Table 7. Series 78 RTD Sensor Assemblies WITH Thermowell**

★ The Standard offering represents the most common options. The starred options (★) should be selected for best delivery lead time.

The Expanded offering is subject to additional delivery lead time.

Thermowell style		Mounting	Stem	
F56	Flanged	2-in., Class 150	Stepped	★
F58 <sup>(8)</sup>	Flanged	1-in., Class 150	Tapered	★
F60	Flanged	1½-in., Class 150	Tapered	★
F62	Flanged	2-in. Class 150	Tapered	★
F64 <sup>(7)</sup>	Flanged	1-in., Class 150	Straight	★
F66	Flanged	1½-in., Class 150	Straight	★
F70 <sup>(7)</sup>	Flanged	1-in., Class 300	Stepped	★
F72	Flanged	1½-in., Class 300	Stepped	★
F74	Flanged	2-in., Class 300	Stepped	★
F76 <sup>(8)</sup>	Flanged	1-in., Class 300	Tapered	★
F78	Flanged	1½-in., Class 300	Tapered	★
F80	Flanged	2-in., Class 300	Tapered	★
F82 <sup>(7)</sup>	Flanged	1-in., Class 300	Straight	★
F84	Flanged	1½-in., Class 300	Straight	★
F86	Flanged	2-in., Class 300	Straight	★
F88 <sup>(7)</sup>	Flanged	1-in., Class 600	Stepped	★
F90 <sup>(9)</sup>	Flanged	1½-in., Class 600	Stepped	★
F92 <sup>(9)</sup>	Flanged	2-in., Class 600	Stepped	★
F94 <sup>(8)(9)</sup>	Flanged	1-in., Class 600	Tapered	★
F96 <sup>(9)</sup>	Flanged	1½-in., Class 600	Tapered	★
F98 <sup>(9)</sup>	Flanged	2-in., Class 600	Tapered	★
F02 <sup>(7)(9)</sup>	Flanged	1-in., Class 600	Straight	★
F04 <sup>(9)</sup>	Flanged	1½-in., Class 600	Straight	★
F06 <sup>(9)</sup>	Flanged	2-in., Class 600	Straight	★
F16 <sup>(9)</sup>	Flanged	1½-in., Class 900	Tapered	★
F34 <sup>(9)</sup>	Flanged	1½-in., Class 1500	Tapered	★
F24 <sup>(9)</sup>	Flanged	2-in., Class 1500	Tapered	★
F08 <sup>(10)</sup>	Flanged	1½-in., Class 2500	Tapered	★
Q02 <sup>(11)</sup>	Sanitary, Tri-Clamp	1-in., Tri-Clamp	Stepped	★
Q04 <sup>(11)</sup>	Sanitary, Tri-Clamp	1½-in., Tri-Clamp	Stepped	★
Q06 <sup>(11)</sup>	Sanitary, Tri-Clamp	2-in., Tri-Clamp	Stepped	★
Q08 <sup>(11)</sup>	Sanitary, Tri-Clamp	3-in., Tri-Clamp	Stepped	★
Q20 <sup>(11)</sup>	Sanitary, Tri-Clamp	¾-in., Tri-Clamp	Straight	★
Q22 <sup>(11)</sup>	Sanitary, Tri-Clamp	1-in., Tri-Clamp	Straight	★
Q24 <sup>(11)</sup>	Sanitary, Tri-Clamp	1½-in., Tri-Clamp	Straight	★
Q26 <sup>(11)</sup>	Sanitary, Tri-Clamp	2-in., Tri-Clamp	Straight	★
Q28 <sup>(11)</sup>	Sanitary, Tri-Clamp	3-in., Tri-Clamp	Straight	★

**Table 7. Series 78 RTD Sensor Assemblies WITH Thermowell**

★ The Standard offering represents the most common options. The starred options (★) should be selected for best delivery lead time. The Expanded offering is subject to additional delivery lead time.

**Options (include with selected model number)**

<b>Sensor</b>		
A <sup>(12)</sup>	IEC 751 Class A Sensor (-200 to 500 °C)	
<b>Approval options</b>		
E1	ATEX Flameproof approval (see <a href="#">Figure 32</a> )	★
E2	Ex d- CEPEL Flameproof Approval- Brazil	★
E5	FM Explosion-proof Approval (see <a href="#">Figure 30</a> )	★
E6	CSA Explosion-proof Approval (see <a href="#">Figure 31</a> )	★
E7	IECEx Flameproof Approval	★
KF	ATEX + CSA Explosion-proof Combination Approval	★
EM	Technical Regulations Customs Union (EAC) Flameproof	★
<b>Callendar-Van Dusen Constant</b>		
V1-V7	Callendar-Van Dusen Constants	★
<b>Calibration schedule</b>		
X8	Customer-Specified Temperature Range Calibration	★
X9	Customer-Specified Single Temperature Point Calibration	★
<b>Calibration certification</b>		
Q4	Calibration Certification, Customer-Specified Temperature	★
<b>A Leadkit</b>		
A1-A8	Twisted lead wire extension: A1 = 1.5 ft, A2 = 3.0 ft, A3 = 6.0 ft, A4 = 12 ft, A5 = 24 ft, A6 = 50 ft, A7 = 75 ft, A8 = 100 ft	★
<b>B Leadkit</b>		
B1-B8	Shielded cable lead wire extension: B1 = 1.5 ft, B2 = 3.0 ft, B3 = 6.0 ft, B4 = 12 ft, B5 = 24 ft, B6 = 50 ft, B7 = 75 ft, B8 = 100 ft	★
<b>C Leadkit</b>		
C1-C8 <sup>(13)</sup>	Armored cable lead wire extension: C1 = 1.5 ft, C2 = 3.0 ft, C3 = 6.0 ft, C4 = 12 ft, C5 = 24 ft, C6 = 50 ft, C7 = 75 ft, C8 = 100 ft	★
<b>D Leadkit</b>		
D1-D8 <sup>(14)</sup>	Armored cable lead wire extensions with electrical plug: D1 = 1.5 ft, D2 = 3.0 ft, D3 = 6.0 ft, D4 = 12 ft, D5 = 24 ft, D6 = 50 ft, D7 = 75 ft, D8 = 100 ft	★
<b>L Leadkit</b>		
L1-L8 <sup>(14)</sup>	Armored cable mating plugs with lead wire extension: L1 = 1.5 ft, L2 = 3.0 ft, L3 = 6.0 ft, L4 = 12 ft, L5 = 24 ft, L6 = 50 ft, L7 = 75 ft, L8 = 100 ft	★
<b>J Leadkit</b>		
J1 <sup>(13)</sup>	Moisture-proof seal assembly for armored cables	★

**Table 7. Series 78 RTD Sensor Assemblies WITH Thermowell**

★ The Standard offering represents the most common options. The starred options (★) should be selected for best delivery lead time.

The Expanded offering is subject to additional delivery lead time.

<b>Special external pressure test</b>		
R01	Special External Pressure Test	★
<b>Material certifications</b>		
Q8	Thermowell Material Certificate	★
<b>Surface finish certification</b>		
Q16	Surface Finish Certification	★
<b>Dye penetration test</b>		
R03	Dye Penetration Test	★
<b>NACE approval</b>		
R05	NACE Approval	★
<b>SST plug and chain</b>		
R06	SST Plug and Chain	★
<b>Full penetration weld</b>		
R07 <sup>(15)</sup>	Full Penetration Weld	★
<b>Thermowell face options</b>		
R09 <sup>(15)(16)</sup>	Concentric Serrations of Thermowell Flange Face	★
<b>Flat faced flange</b>		
R10 <sup>(15)(16)</sup>	Flat Faced Flange	★
<b>Vent hole</b>		
R11	Vent Hole	★
<b>Thermowell Xray</b>		
R12	Thermowell Xray	★
<b>Special surface finish</b>		
R14	Special Surface Finish (12 RA) (Maximum "U" length = 22.5-in.)	★
<b>Ring joint flange</b>		
R16 <sup>(15)(16)</sup>	Ring Joint Flange (not available with 0-in. [T] length)	★
<b>Electropolish</b>		
R20 <sup>(17)</sup>	Electropolish	★
<b>Wake frequency</b>		
R21	Wake Frequency - Thermowell Strength Calculation	★
<b>Internal pressure test</b>		
R22	Internal Pressure Test	★

**Table 7. Series 78 RTD Sensor Assemblies WITH Thermowell**

★ The Standard offering represents the most common options. The starred options (★) should be selected for best delivery lead time. The Expanded offering is subject to additional delivery lead time.

<b>Brass plug and chain</b>		
R23	Brass plug and chain	★
<b>Canadian registration no.</b>		
R24	CRN Marking for British Columbia	
R25	CRN Marking for Alberta	
R26	CRN Marking for Saskatchewan	
R27	CRN Marking for Manitoba	
R28	CRN Marking for Ontario	
R29	CRN Marking for Quebec	
R30	CRN Marking for New Brunswick	
R31	CRN Marking for Nova Scotia	
R32	CRN Marking for Prince Edward Island	
R33	CRN Marking for Yukon Territory	
R34	CRN Marking for Northwest Territory	
R35	CRN Marking for Nunavut	
R36	CRN Marking for Newfoundland and Labrador	
<b>Twel from hex stock</b>		
R37	Thermowell from Hex Stock	
<b>Assemble to option</b>		
XA <sup>(18)</sup>	Assemble Connection Head or Transmitter to a Sensor Assembly.	★

(1) Not available with Sensor Lead Wire Termination codes R, P, or C or with Approval Options.

(2) Codes A and C must be used with an extension length. Additional non-standard (E) lengths are available in 1/2-in. increments from 2.5 to 9-in.

(3) Available only with straight stem flanged thermowells.

(4) Thermowells with an overall length (“U” + “T” + 1.75-in.) of 36-in. or less are machined from solid barstock. Thermowells with an overall length larger than 42-in. will be constructed using a welded 3-piece design and are available only with a stepped stem style. For lengths between 36-in. and 42-in. consult factory for construction method.

(5) For additional (T) lengths, see [Table 18](#).

(6) Straight or Tapered stem only.

(7) F52, F64, F70, F82, F88, and F02 are not compatible with 1-in. Sch. XXS pipe.

(8) F58, F76, and F94 may not be compatible with 1-in. Sch. pipe and are not compatible with 1-in. Sch. 80, 160, or XXS pipe.

(9) These options cannot be used with 0-in. (T) length.

(10) F08 cannot be used with 0- or 1/2-in. (T) length.

(11) Limited to 24” immersion length and 316 or 304 SST materials only.

(12) The IEC 751 Class A option is not available with high-temperature sensors.

(13) These options are not available with Sensor Lead Wire Termination codes T, L, or N.

- (14) Only available with sensor Lead Wire Termination code N.
- (15) Available on flanged thermowells only.
- (16) Only one flange face option allowed.
- (17) Not available on flanged Thermowells and (L) lengths longer than 24-in.
- (18) If ordering option code XA with a transmitter, specify the same option on the transmitter model code.

**Table 8. Ordering Example**

Typical Model Number	Model	Lead wire termination	Sensor type	Extension type	Extension length	Material code	Immersion length	Mounting style	Additional options
	0078	N	21	A	30	A	075	T22	E5

# Rosemount 183 Sensor and Thermowell

The Rosemount 183 Sensor and Thermowell have designs that provide flexible and reliable temperature measurements in process environments.

Features include:

- Industry-standard sensor types, including J, K, E, and T thermocouple varieties
- Variety of enclosure and connection head options
- Global hazardous-location approvals (Option Codes E5, E6, E7)
- Assemble to Transmitter option (Option Code XA)



**Table 9. Series 183 Thermocouple Sensor Assemblies WITHOUT Thermowell**

★ The Standard offering represents the most common options. The starred options (★) should be selected for best delivery lead time. The Expanded offering is subject to additional delivery lead time.

Model	Product description		
0183	Thermocouple Sensor without Thermowell		
<b>Connection head</b>			
R	Aluminum Connection Head, Six Terminals, Flat Cover, Unpainted		★
T	Aluminum Connection Head, Six Terminals, Extended Cover, Unpainted		★
P	Aluminum Connection Head, Six Terminals, Flat Cover, Painted		★
L	Aluminum Connection Head, Six Terminals, Extended Cover, Painted		★
N	Sensor only with 6-in. PTFE-insulated, 20-gauge Lead Wires		★
D	Rosemount Aluminum Connection Head with 1/2-in. Entries		★
C	Polypropylene Connection Head		
G	Rosemount SST Connection Head with 1/2-in. Entries		
<b>Sensor type</b>		<b>Junction</b>	
<b>Capsule sensor<sup>(1)(2)</sup></b>			
01	Single	Grounded	★
02	Dual	Grounded	★
03	Single	Ungrounded	★
04	Dual, Unisolated	Ungrounded	★
05	Dual, Isolated	Ungrounded	★
<b>General purpose sensors<sup>(3)</sup></b>			
11	Single	Grounded	★
12	Dual	Grounded	★
13	Single	Ungrounded	★
14	Dual, Unisolated	Ungrounded	★
15	Dual, Isolated	Ungrounded	★

**Table 9. Series 183 Thermocouple Sensor Assemblies WITHOUT Thermowell**

★ The Standard offering represents the most common options. The starred options (★) should be selected for best delivery lead time.  
The Expanded offering is subject to additional delivery lead time.

Sensor type		Junction	
<b>Spring-loaded sensors</b>			
21	Single	Grounded	★
22	Dual	Grounded	★
23	Single	Ungrounded	★
24	Dual, Unisolated	Ungrounded	★
25	Dual, Isolated	Ungrounded	★
<b>Bayonet spring-loaded sensors<sup>(4)</sup></b>			
31	Single	Grounded	
32	Dual	Grounded	
33	Single	Ungrounded	
34	Dual, Unisolated	Ungrounded	
35	Dual, Isolated	Ungrounded	
<b>Thermocouple type</b>		<b>Temperature range</b>	
J2	J	0 to 760 °C (32 to 1400 °F)	★
K2	K	0 to 1150 °C (32 to 2102 °F)	★
E2	E	0 to 871 °C (32 to 1600 °F)	★
T2	T	-180 to 371 °C (-292 to 700 °F)	★
<b>Extension type</b>		<b>Extension type material</b>	
A <sup>(5)</sup>	Nipple Coupling	300 series SST	★
C <sup>(5)</sup>	Nipple Union	300 series SST	★
N	None (use with extension length option code 00)	None	★
<b>Extension length (E)</b>			
00	0.0 in.		★
30	3.0 in.		★
60	6.0 in.		★
<b>Thermowell material</b>			
N	No Thermowell Required		★
<b>Code</b>	<b>Sensor immersion length (L)</b>		
020	2.0-in.		★
025	2.5-in.		★
030	3.0-in.		★
035	3.5-in.		★
040	4.0-in.		★
045	4.5-in.		★
050	5.0-in.		★



**Table 9. Series 183 Thermocouple Sensor Assemblies WITHOUT Thermowell**

★ The Standard offering represents the most common options. The starred options (★) should be selected for best delivery lead time.  
The Expanded offering is subject to additional delivery lead time.

Code	Sensor immersion length (L)	
055	5.5-in.	★
060	6.0-in.	★
065	6.5-in.	★
070	7.0-in.	★
075	7.5-in.	★
080	8.0-in.	★
085	8.5-in.	★
090	9.0-in.	★
095	9.5-in.	★
100	10.0-in.	★
105	10.5-in.	★
110	11.0-in.	★
115	11.5-in.	★
120	12.0-in.	★
125	12.5-in.	★
130	13.0-in.	★
135	13.5-in.	★
140	14.0-in.	★
145	14.5-in.	★
150	15.0-in.	★
155	15.5-in.	★
160	16.0-in.	★
165	16.5-in.	★
170	17.0-in.	★
175	17.5-in.	★
180	18.0-in.	★
185	18.5-in.	★
190	19.0-in.	★
195	19.5-in.	★
200	20.0-in.	★
205	20.5-in.	★
210	21.0-in.	★
215	21.5-in.	★
220	22.0-in.	★
225	22.5-in.	★
230	23.0-in.	★
240	24.0-in.	★

**Table 9. Series 183 Thermocouple Sensor Assemblies WITHOUT Thermowell**

★ The Standard offering represents the most common options. The starred options (★) should be selected for best delivery lead time.

The Expanded offering is subject to additional delivery lead time.

Code	Sensor immersion length (L)	
250	25.0-in.	★
260	26.0-in.	★
270	27.0-in.	★
280	28.0-in.	★
290	29.0-in.	★
300	30.0-in.	★
310	31.0-in.	★
320	32.0-in.	★
330	33.0-in.	★
340	34.0-in.	★
350	35.0-in.	★
360	36.0-in.	★
370	37.0-in.	★
380	38.0-in.	★
390	39.0-in.	★
400	40.0-in.	★
410	41.0-in.	★
420	42.0-in.	★
430	43.0-in.	★
440	44.0-in.	★
450	45.0-in.	★
460	46.0-in.	★
470	47.0-in.	★
480	48.0-in.	★

### Options (include with selected model number)

Product certifications		
E1	ATEX Flameproof approval (See <a href="#">Figure 32</a> )	★
E1	Ex d- CEPEL Flameproof Approval- Brazil	★
E5	FM Explosion-proof approval (See <a href="#">Figure 30</a> )	★
E6	CSA Explosion-proof approval (See <a href="#">Figure 31</a> )	★
E7	IECEX Flameproof approval	★
KF	ATEX + CSA Explosion-proof Combination Approval	★
EM	Technical Regulations Customs Union (EAC) Flameproof	★

**Table 9. Series 183 Thermocouple Sensor Assemblies WITHOUT Thermowell**

★ The Standard offering represents the most common options. The starred options (★) should be selected for best delivery lead time. The Expanded offering is subject to additional delivery lead time.

<b>Mounting adapter</b>		
M5-M7	Mounting adapter; Sensor Compression Fitting: M5= 1/8-27 NPT, M6= 1/4-18 NPT, M7= 1/2-14 NPT	★
<b>Assembly options</b>		
XA <sup>(6)</sup>	Assemble connection head or transmitter to a sensor assembly	★

- (1) Capsule style available in 1-in. increments only, starting at 1-in.
- (2) This option can only be used with Sensor Lead wire Termination Code N and is not available with assembly code XA or with Approval Options.
- (3) General-purpose Sensors are only available in (L) lengths of 2.4-in. or greater. General purpose sensors are not available with Type K Thermocouples.
- (4) Bayonet spring-loaded style is available to 21-inches but is not available with Sensor Lead Wire Termination codes R, P, or C or with Approval Options.
- (5) Codes A and C must be used with an extension length.
- (6) If ordering option code XA with a transmitter, specify the same option on the transmitter model code.

**Table 10. Ordering Example**

Typical Model Number	Model	Lead wire termination	Sensor type	ISA type	Extension type	Extension length	Thermowell code	Immersion length	Additional options
	0183	N	11	J2	N	00	N	045	E5

**Table 11. Series 183 Thermocouple Sensor Assemblies WITH Thermowell**

★ The Standard offering represents the most common options. The starred options (★) should be selected for best delivery lead time.  
The Expanded offering is subject to additional delivery lead time.

Model	Product description		
0183	Thermocouple Sensor with Thermowell		
<b>Sensor lead wire termination</b>			
R	Aluminum Connection Head, Six Terminals, Flat Cover, Unpainted		★
T	Aluminum Connection Head, Six Terminals, Extended Cover, Unpainted		★
P	Aluminum Connection Head, Six Terminals, Flat Cover, Painted		★
L	Aluminum Connection Head, Six Terminals, Extended Cover, Painted		★
N	Sensor Only with 6-in. PTFE-insulated, 20-gauge Lead Wires		★
D	Rosemount Aluminum Connection Head with 1/2-in. Entries		★
C	Polypropylene Connection Head		
G	Rosemount SST Connection Head with 1/2-in. Entries		
<b>Sensor type</b>		<b>Junction</b>	
<b>General-purpose sensors<sup>(1)</sup></b>			
11	Single	Grounded	★
12	Dual	Grounded	★
13	Single	Ungrounded	★
14	Dual, Unisolated	Ungrounded	★
15	Dual, Isolated		★
<b>Spring-loaded sensors</b>			
21	Single	Grounded	★
22	Dual	Grounded	★
23	Single	Ungrounded	★
24	Dual, Unisolated	Ungrounded	★
25	Dual, Isolated	Ungrounded	★
<b>Bayonet spring-loaded sensors<sup>(2)</sup></b>			
31	Single	Grounded	
32	Dual	Grounded	
33	Single	Ungrounded	
34	Dual, Unisolated	Ungrounded	
35	Dual, Isolated	Ungrounded	
<b>Thermocouple type</b>		<b>Temperature range</b>	
J2	J	0 to 760 °C (32 to 1400 °F)	★
K2	K	0 to 1150 °C (32 to 2102 °F)	★
E2	E	0 to 871 °C (32 to 1600 °F)	★
T2	T	-180 to 371 °C (-292 to 700 °F)	★

**Table 11. Series 183 Thermocouple Sensor Assemblies WITH Thermowell**

★ The Standard offering represents the most common options. The starred options (★) should be selected for best delivery lead time.  
The Expanded offering is subject to additional delivery lead time.

Extension type		Extension type material		
A <sup>(3)</sup>	Nipple Coupling	300 series SST		★
C <sup>(3)</sup>	Nipple Union	300 series SST		★
N	None (use with extension length option code 00)	None		★
Extension length (E)				
00	0.0 in.			★
30	3.0 in.			★
60	6.0 in.			★
Thermowell material				
A	316 SST			★
B	304 SST			★
C	Carbon Steel			★
D	316L SST			★
E	304L SST			★
F	Alloy 20			
G	Alloy 400			
H	Alloy 600			
J	Alloy C-276			
L	Alloy B			
M	304 SST with PTFE coating			
P	Chrome Molybdenum Grade F22			
R	Nickel 200			
T	Titanium			
U <sup>(4)</sup>	316 SST with Tantalum Sheath			
V	310 SST			
W	321 SST			
Z	Chrome Molybdenum Grade F11			
Immersion length (U) <sup>(5)</sup>		Thermowell length (L)	Lagging length (T) <sup>(6)</sup>	
015 <sup>(7)</sup>	1.5-in.	4.0-in.	1.0-in.	
020 <sup>(6)</sup>	2.0-in.	4.0-in.	0.5-in.	
025 <sup>(6)</sup>	2.5-in.	4.0-in.	0.0-in.	
030	3.0-in.	6.0-in.	1.5-in.	
035	3.5-in.	6.0-in.	1.0-in.	
040	4.0-in.	6.0-in.	0.5-in.	
045	4.5-in.	6.0-in.	0.0-in.	
050	5.0-in.	9.0-in.	2.5-in.	
055	5.5-in.	9.0-in.	2.0-in.	

**Table 11. Series 183 Thermocouple Sensor Assemblies WITH Thermowell**

★ The Standard offering represents the most common options. The starred options (★) should be selected for best delivery lead time.  
The Expanded offering is subject to additional delivery lead time.

Immersion length (U) <sup>(5)</sup>		Thermowell length (L)	Lagging length (T) <sup>(6)</sup>	
060	6.0-in.	9.0-in.	1.5-in.	★
065	6.5-in.	9.0-in.	1.0-in.	★
070	7.0-in.	9.0-in.	0.5-in.	★
075	7.5-in.	9.0-in.	0.0-in.	★
080	8.0-in.	12.0-in.	2.5-in.	★
085	8.5-in.	12.0-in.	2.0-in.	★
090	9.0-in.	12.0-in.	1.5-in.	★
095	9.5-in.	12.0-in.	1.0-in.	★
100	10.0-in.	12.0-in.	0.5-in.	★
105	10.5-in.	12.0-in.	0.0-in.	★
110	11.0-in.	15.0-in.	2.5-in.	★
115	11.5-in.	15.0-in.	2.0-in.	★
120	12.0-in.	15.0-in.	1.5-in.	★
125	12.5-in.	15.0-in.	1.0-in.	★
130	13.0-in.	15.0-in.	0.5-in.	★
135	13.5-in.	15.0-in.	0.0-in.	★
140	14.0-in.	18.0-in.	2.5-in.	★
145	14.5-in.	18.0-in.	2.0-in.	★
150	15.0-in.	18.0-in.	1.5-in.	★
155	15.5-in.	18.0-in.	1.0-in.	★
160	16.0-in.	18.0-in.	0.5-in.	★
165	16.5-in.	18.0-in.	0.0-in.	★
170	17.0-in.	21.0-in.	2.5-in.	★
175	17.5-in.	21.0-in.	2.0-in.	★
180	18.0-in.	21.0-in.	1.5-in.	★
185	18.5-in.	21.0-in.	1.0-in.	★
190	19.0-in.	21.0-in.	0.5-in.	★
195	19.5-in.	21.0-in.	0.0-in.	★
200	20.0-in.	24.0-in.	2.5-in.	★
205	20.5-in.	24.0-in.	2.0-in.	★
210	21.0-in.	24.0-in.	1.5-in.	★
215	21.5-in.	24.0-in.	1.0-in.	★
220	22.0-in.	24.0-in.	0.5-in.	★
225	22.5-in.	24.0-in.	0.0-in.	★
230	23.0-in.	27.0-in.	2.5-in.	
240	24.0-in.	27.0-in.	1.5-in.	
250	25.0-in.	27.0-in.	0.5-in.	

**Table 11. Series 183 Thermocouple Sensor Assemblies WITH Thermowell**

★ The Standard offering represents the most common options. The starred options (★) should be selected for best delivery lead time.  
The Expanded offering is subject to additional delivery lead time.

Immersion length (U) <sup>(5)</sup>		Thermowell length (L)	Lagging length (T) <sup>(6)</sup>	
260	26.0-in.	30.0-in.	2.5-in.	
270	27.0-in.	30.0-in.	1.5-in.	
280	28.0-in.	30.0-in.	0.5-in.	
290	29.0-in.	33.0-in.	2.5-in.	
300	30.0-in.	33.0-in.	1.5-in.	
310	31.0-in.	33.0-in.	0.5-in.	
320	32.0-in.	36.0-in.	2.5-in.	
330	33.0-in.	36.0-in.	1.5-in.	
340	34.0-in.	36.0-in.	0.5-in.	
350	35.0-in.	39.0-in.	2.5-in.	
360	36.0-in.	39.0-in.	1.5-in.	
370	37.0-in.	39.0-in.	0.5-in.	
380	38.0-in.	42.0-in.	2.5-in.	
390	39.0-in.	42.0-in.	1.5-in.	
400	40.0-in.	42.0-in.	0.5-in.	
410	41.0-in.	45.0-in.	2.5-in.	
420	42.0-in.	45.0-in.	1.5-in.	
430	43.0-in.	45.0-in.	0.5-in.	
440	44.0-in.	48.0-in.	2.5-in.	
450	45.0-in.	48.0-in.	1.5-in.	
460	46.0-in.	48.0-in.	0.5-in.	
470	47.0-in.	51.0-in.	2.5-in.	
480	48.0-in.	51.0-in.	1.5-in.	
Thermowell style		Mounting	Stem	
T20	Threaded	1/2-14 ANPT	Stepped	★
T22	Threaded	3/4-14 ANPT	Stepped	★
T24	Threaded	1-11.5 ANPT	Stepped	★
T26	Threaded	3/4-14 ANPT	Tapered	★
T28	Threaded	1-11.5 ANPT	Tapered	★
T30	Threaded	1 1/2-11 ANPT	Tapered	★
T32	Threaded	1/2-14 ANPT	Straight	★
T34	Threaded	3/4-14 ANPT	Straight	★
T36	Threaded	1-11.5 ANPT	Straight	★
T38	Threaded	3/4-14 ANPT	Straight	★
T44	Threaded	1/2-14 ANPT	Tapered	★
W38	Welded	3/4-in. pipe	Stepped	★

**Table 11. Series 183 Thermocouple Sensor Assemblies WITH Thermowell**

★ The Standard offering represents the most common options. The starred options (★) should be selected for best delivery lead time.  
The Expanded offering is subject to additional delivery lead time.

Thermowell style		Mounting	Stem	
W40	Welded	1-in. pipe	Stepped	★
W42	Welded	3/4-in. pipe	Tapered	★
W44	Welded	1-in. pipe	Tapered	★
W46	Welded	1 1/4-in. pipe	Tapered	★
W48	Welded	3/4-in. pipe	Straight	★
W50	Welded	1-in. pipe	Straight	★
F10	Flanged	2-in., Class 150	Straight	★
F12	Flanged	3-in., Class 150	Straight	★
F52 <sup>(8)</sup>	Flanged	1-in., Class 150	Stepped	★
F54	Flanged	1 1/2-in., Class 150	Stepped	★
F56	Flanged	2-in., Class 150	Stepped	★
F58 <sup>(9)</sup>	Flanged	1-in., Class 150	Tapered	★
F60	Flanged	1 1/2-in., Class 150	Tapered	★
F62	Flanged	2-in. Class 150	Tapered	★
F64 <sup>(8)</sup>	Flanged	1-in., Class 150	Straight	★
F66	Flanged	1 1/2-in., Class 150	Straight	★
F70 <sup>(8)</sup>	Flanged	1-in., Class 300	Stepped	★
F72	Flanged	1 1/2-in., Class 300	Stepped	★
F74	Flanged	2-in., Class 300	Stepped	★
F76 <sup>(9)</sup>	Flanged	1-in., Class 300	Tapered	★
F78	Flanged	1 1/2-in., Class 300	Tapered	★
F80	Flanged	2-in., Class 300	Tapered	★
F82 <sup>(8)</sup>	Flanged	1-in., Class 300	Straight	★
F84	Flanged	1 1/2-in., Class 300	Straight	★
F86	Flanged	2-in., Class 300	Straight	★
F88 <sup>(8)</sup>	Flanged	1-in., Class 600	Stepped	★
F90 <sup>(10)</sup>	Flanged	1 1/2-in., Class 600	Stepped	★
F92 <sup>(10)</sup>	Flanged	2-in., Class 600	Stepped	★
F94 <sup>(9)(10)</sup>	Flanged	1-in., Class 600	Tapered	★
F96 <sup>(10)</sup>	Flanged	1 1/2-in., Class 600	Tapered	★
F98 <sup>(10)</sup>	Flanged	2-in., Class 600	Tapered	★
F02 <sup>(8)(10)</sup>	Flanged	1-in., Class 600	Straight	★
F04 <sup>(10)</sup>	Flanged	1 1/2-in., Class 600	Straight	★
F06 <sup>(10)</sup>	Flanged	2-in., Class 600	Straight	★
F16 <sup>(10)</sup>	Flanged	1 1/2-in., Class 900	Tapered	★
F34 <sup>(10)</sup>	Flanged	1 1/2-in., Class 1500	Tapered	★
F24 <sup>(10)</sup>	Flanged	2-in., Class 1500	Tapered	★



**Table 11. Series 183 Thermocouple Sensor Assemblies WITH Thermowell**

★ The Standard offering represents the most common options. The starred options (★) should be selected for best delivery lead time.  
The Expanded offering is subject to additional delivery lead time.

Thermowell style		Mounting	Stem	
F08 <sup>(11)</sup>	Flanged	1 1/2-in., Class 2500	Tapered	★
Q02 <sup>(12)</sup>	Sanitary, Tri-Clamp	1-in., Tri-Clamp	Stepped	★
Q04 <sup>(12)</sup>	Sanitary, Tri-Clamp	1 1/2-in., Tri-Clamp	Stepped	★
Q06 <sup>(12)</sup>	Sanitary, Tri-Clamp	2-in., Tri-Clamp	Stepped	★
Q08 <sup>(12)</sup>	Sanitary, Tri-Clamp	3-in., Tri-Clamp	Stepped	★
Q20 <sup>(12)</sup>	Sanitary, Tri-Clamp	3/4-in., Tri-Clamp	Straight	★
Q22 <sup>(12)</sup>	Sanitary, Tri-Clamp	1-in., Tri-Clamp	Straight	★
Q24 <sup>(12)</sup>	Sanitary, Tri-Clamp	1 1/2-in., Tri-Clamp	Straight	★
Q26 <sup>(12)</sup>	Sanitary, Tri-Clamp	2-in., Tri-Clamp	Straight	★
Q28 <sup>(12)</sup>	Sanitary, Tri-Clamp	3-in., Tri-Clamp	Straight	★

### Options (include with selected model number)

Product certifications		
E1	ATEX Approval (See <a href="#">Figure 32</a> )	★
E2	Ex d- CEPEL Flameproof Approval- Brazil	★
E5	FM Explosion-proof Approval (See <a href="#">Figure 30</a> )	★
E6	CSA Explosion-proof Approval (See <a href="#">Figure 31</a> )	★
E7	IECEx Flameproof Approval	★
KF	ATEX + CSA Explosion-proof Combination Approval	★
EM	Technical Regulations Customs Union (EAC) Flameproof	★
Special External pressure test		
R01	Special External Pressure Test	★
Material certification		
Q8	Material Certification	★
Dye penetration test		
R03	Dye Penetration Test	★
NACE Approval		
R05	NACE Approval	★
SST plug and chain		
R06	SST Plug and Chain	★
Full penetration weld		
R07 <sup>(15)</sup>	Full Penetration Weld	★
Thermowell concentric serrations		
R09 <sup>(13)(14)</sup>	Concentric Serrations of Thermowell Flange Face	★

**Table 11. Series 183 Thermocouple Sensor Assemblies WITH Thermowell**

★ The Standard offering represents the most common options. The starred options (★) should be selected for best delivery lead time.  
The Expanded offering is subject to additional delivery lead time.

<b>Flat faced flange</b>		
R10 <sup>(13)(14)</sup>	Flat Faced Flange	★
<b>Vent hole</b>		
R11	Vent Hole	★
<b>Thermowell Xray</b>		
R12	Thermowell Xray	★
<b>Special surface finish</b>		
R14	Special Surface Finish (12 Ra) (Maximum "U" length = 48-in.)	★
<b>Ring joint flange</b>		
R16 <sup>(13)(14)</sup>	Ring joint flange (not available with 0-in. [T] length)	★
<b>Electropolish</b>		
R20 <sup>(15)</sup>	Electropolish	★
<b>Wake frequency</b>		
R21	Wake Frequency-Thermowell Strength Calculation	★
<b>Internal pressure test</b>		
R22	Internal Pressure Test	★
<b>Brass plug and chain</b>		
R23	Brass plug and chain	★
<b>Canadian registration no.</b>		
R24	CRN Marking for British Columbia	
R25	CRN Marking for Alberta	
R26	CRN Marking for Saskatchewan	
R27	CRN Marking for Manitoba	
R28	CRN Marking for Ontario	
R29	CRN Marking for Quebec	
R30	CRN Marking for New Brunswick	
R31	CRN Marking for Nova Scotia	
R32	CRN Marking for Prince Edward Island	
R33	CRN Marking for Yukon Territory	
R34	CRN Marking for Northwest Territory	
R35	CRN Marking for Nunavut	
R36	CRN Marking for Newfoundland and Labrador	

**Table 11. Series 183 Thermocouple Sensor Assemblies WITH Thermowell**

★ The Standard offering represents the most common options. The starred options (★) should be selected for best delivery lead time. The Expanded offering is subject to additional delivery lead time.

<b>Twell from hex stock</b>		
R37	Thermowell from Hex stock	
<b>Assemble to options</b>		
XA <sup>(16)</sup>	Assemble connection head or transmitter to a sensor assembly	★

- (1) General purpose sensors are not available with Type K Thermocouples.
- (2) Bayonet spring-loaded style is available to 21-inches but is not available with Sensor Lead Wire Termination codes R, P, or C or with Approval Options.
- (3) Codes A and C must be used with an extension length. Additional non-standard (E) lengths are available in 1/2-in. increments from 2.5 to 9-in.
- (4) Available only with straight stem flanged thermowells.
- (5) Thermowells with an overall length (“U” + “T” + 1.75-in.) of 36-in. or less are machined from solid barstock. Thermowells with an overall length larger than 42-in. will be constructed using a welded 3-piece design and are available only with a stepped stem style.
- (6) For additional (T) lengths, see [Table 18](#).
- (7) Straight or tapered stem thermowells only.
- (8) F52, F64, F20, F82, F88, and F02 are not compatible with 1-in. Sch. XXS pipe.
- (9) F58, F76, and F94 may not be compatible with 1-in. Sch. pipe and are not compatible with 1-in. Sch. 80, 160 or XXS pipe.
- (10) These options cannot be used with 0-in. (T) length.
- (11) F08 cannot be used with 0- or 1/2-in. (T) length.
- (12) Limited to 24-in. immersion length and 316 or 304 SST materials only.
- (13) Available on flanged thermowells only.
- (14) Only one flange face option allowed.
- (15) Not available on flanged Thermowell and L lengths larger than 24-in.
- (16) If ordering option code XA with a transmitter, specify the same option on the transmitter model code.

**Table 12. Ordering Example**

Typical Model Number	Model	Connection head	Sensor type	ISA type	Extension type	Extension length	Material code	Immersion length	Mounting style	Additional options
	0183	N	21	J2	A	30	A	075	T22	E5

## Rosemount 68Q Sanitary Sensor



The Rosemount 68Q Sanitary Sensor has designs that provide flexible and reliable temperature measurements in hygienic process environments.

Features include:

- Industry-standard RTD sensor design
- Tri-Clamp endcap designs for easy installation
- 3-A Standards approval
- Variety of enclosure and connection head options
- Calibration services to give you insight to sensor performance (Option Codes V1-V7)
- Electropolishing Surface Finish (Option Code R20)
- Assemble to Transmitter option (Option Code XA)

**Table 13. Series 68Q Sanitary Platinum RTD Sensor Assemblies**

★ The Standard offering represents the most common options. The starred options (★) should be selected for best delivery lead time. The Expanded offering is subject to additional delivery lead time.

Model	Product description	
0068Q	Sanitary Platinum RTD Sensor Assembly	
<b>Sensor lead wire termination</b>		
P	Aluminum Connection Head, Six Terminals, Flat Cover, Painted	★
L	Aluminum Connection Head, Six Terminals, Extended Cover, Painted	★
N	Sensor only	★
D	Rosemount Aluminum Connection Head with 1/2-in. Entries	★
C	Polypropylene Connection Head	
G	Rosemount SST Connection Head with 1/2-in. Entries	
<b>Sensor type</b>		<b>Temperature range</b>
		-50 to 200 °C (-58 to 392 °F)
11	Single Stepped Stem	★
15	Dual Stepped Stem	★
21	Single Straight Stem	★
25	Dual Straight Stem	★
30 <sup>(1)(2)</sup>	Mini General Purpose 6-in. Lead with 1/2-in. NPT Threaded Adapter	★
31 <sup>(1)(2)(3)</sup>	Mini General Purpose 6-in. Lead with 1/2-in. NPSM Threaded Adapter	★
32 <sup>(1)(2)(3)</sup>	Mini General Purpose 180-in. Cable with Strain Relief	★
33 <sup>(1)(2)(3)</sup>	Mini General Purpose 300-in. Cable with Strain Relief	★
41 <sup>(2)(4)</sup>	Mini Spring Loaded with Thermowell Replacement Sensor	★

**Table 13. Series 68Q Sanitary Platinum RTD Sensor Assemblies**

★ The Standard offering represents the most common options. The starred options (★) should be selected for best delivery lead time.  
The Expanded offering is subject to additional delivery lead time.

Sensor immersion length			
U010		1.00-in.	★
U011		1.10-in.	★
U012		1.20-in.	★
U013		1.25-in.	★
U014		1.40-in.	★
U015		1.50-in.	★
U016		1.60-in.	★
U017		1.70-in.	★
U018		1.80-in.	★
U019		1.90-in.	★
U020		2.00-in.	★
U025		2.50-in.	★
U030		3.00-in.	★
U035		3.50-in.	★
U040		4.00-in.	★
U045		4.50-in.	★
U050		5.00-in.	★
U055		5.50-in.	★
U060		6.00-in.	★
U065		6.50-in.	★
U070		7.00-in.	★
U075		7.50-in.	★
U080		8.00-in.	★
U085		8.50-in.	★
U090		9.00-in.	★
U095		9.50-in.	★
Endcap type			
L050 <sup>(5)</sup>	Tri-Clamp	$1/2$ -in. to $3/4$ -in.	★
L100	Tri-Clamp	1.00-in.	★
L150	Tri-Clamp	1.50-in.	★
L200	Tri-Clamp	2.00-in.	★
L250	Tri-Clamp	2.50-in.	★
L300	Tri-Clamp	3.00-in.	★

**Table 13. Series 68Q Sanitary Platinum RTD Sensor Assemblies**

★ The Standard offering represents the most common options. The starred options (★) should be selected for best delivery lead time. The Expanded offering is subject to additional delivery lead time.

**Options (include with selected model number)**

<b>Callendar-Van Dusen constants</b>		
V1-V7	Callendar-Van Dusen Constants (V3, V4, V6 not available with 68Q)	★
<b>Calibration schedule</b>		
X8	Customer-Specified Temperature Range Calibration	★
X9	Customer-Specified Single Temperature Point Calibration	★
<b>Calibration certification</b>		
Q4	Calibration Certification, Customer-Specified Temperature	★
<b>Special surface finish electro polish</b>		
R20 <sup>(6)</sup>	Electropolishing of Wetted Surfaces	★
<b>Special surface finish high mechanical polish</b>		
HP	High Mechanical Polish (15R <sub>a</sub> or better)	★
<b>Thermowell material certification</b>		
Q8	Material Certification	★
<b>Surface finish certification</b>		
Q16	Surface Finish Certification	★
<b>Assemble to options</b>		
XA <sup>(7)</sup>	Assemble Connection Head or Transmitter to a Sensor Assembly.	★

(1) Only available in Sensor Immersion Lengths between 1-in. and 2-in.

(2) Only available with Tri-Clamp O.D. tube size  $\frac{1}{2}$ -in. to  $\frac{3}{4}$ -in. (Endcap Type code L050).

(3) Only available with Sensor Lead Wire Termination code N (Sensor Only).

(4) Only available in U lengths of 2-, 2.5-, or 3-in.

(5) Only available in Sensor Type code 30, 31, 32, 33, 41.

(6) If ordering a Mini General Purpose or Mini Spring Loaded Sensor (Sensor Type codes 30, 31, 32, 33, or 41) with Electropolishing, High Mechanical Polish (Option code HP) is also required.

(7) If ordering option code XA with a transmitter, specify the same option on the transmitter model code.

**Table 14. Ordering Example**

Typical Model Number	Model	Connection head	Sensor type	Immersion length	Endcap type, tube size	Additional options
	0068Q	N	11	U050	L150	V2

## Rosemount 58C Cut-to-Fit Sensor

The Rosemount 58C Cut-to-Fit Sensor has designs that provide flexible and reliable temperature measurements in process environments.

Features include:

- Industry-standard RTD sensor design
- Cut-to-fit eliminates need to stock large selection of sensors in specific lengths
- 12-, 24-, 36-, and 48-in. lengths available

**Table 15. Series 58C Cut-to-Fit RTD Sensors**

★ The Standard offering represents the most common options. The starred options (★) should be selected for best delivery lead time. The Expanded offering is subject to additional delivery lead time.

Model	Product description	
0058C	Platinum Resistance Temperature Sensor	
<b>Connection head</b>		
D	Rosemount Aluminum Connection Head with 1/2-in. Entries	★
R	Aluminum Connection Head, Six Terminals, Flat Cover, Unpainted	★
T	Aluminum Connection Head, Six Terminals, Extended Cover, Unpainted	★
P	Aluminum Connection Head, Six Terminals, Flat Cover, Painted	★
L	Aluminum Connection Head, Six Terminals, Extended Cover, Painted	★
N	Sensor only with 6-in. PTFE-insulated, 24-gauge Lead Wires	★
C	Polypropylene Connection Head	
G	Rosemount SST Connection with 1/2-in. Entries	
<b>Sensor immersion length</b>		
1200	12-in.	★
2400	24-in.	★
3600	36-in.	★
4800	48-in.	★
<b>Mounting adapter</b>		
NNN	None	★
C01 <sup>(1)</sup>	One-compression Fitting 1/2-14 ANPT	★
C02 <sup>(1)</sup>	Two-compression Fittings 1/2-14 ANPT	★
SNN	Spring-loaded Fitting 1/2-14 ANPT	★

(1) The only difference between C01 and C02 is that the C01 includes one fitting, and the C02 option includes two fittings.

**Table 16. Ordering Example**

Typical Model Number	Model	Connection head	Sensor length	Mounting adapter
	0058C	R	1200	SNN

**Table 17. Series 58C Spare Parts List (specify spare part number separately when ordering mounting adapters)**

Mounting adapters	Option code	Spare part number
Compression fitting 1/2-14 ANPT	C01 and C02	C07961-0008
Spring loaded fitting 1/2-14 ANPT	SNN	00058-0010-0001



# Rosemount 91 Series Thermowells



The Rosemount 91 Series Thermowells have designs that provide flexible and reliable temperature measurements in process environments.

Features include:

- Threaded, Flanged, and Weld-in Styles
- Wake Frequency Calculations (Option Code R21)
- NACE Approval (Option Code R05)
- Internal Pressure Test (Option Code R22)
- External Pressure Test (Option Code R01)

**Table 18. Series 91 Thermowells**

★ The Standard offering represents the most common options. The starred options (★) should be selected for best delivery lead time. The Expanded offering is subject to additional delivery lead time.

Model	Description	
0091	Thermowell	
<b>Thermowell material</b>		
A	316 SST	★
B	304 SST	★
C	Carbon Steel	★
D	316L SST	★
E	304L SST	★
F	Alloy 20	
G	Alloy 400	
H	Alloy 600	
J	Alloy C-276	
L	Alloy B	
M	304 SST with PTFE Coating	
P	Chrome Molybdenum GradeF22	
R	Nickel 200	
T	Titanium	
U <sup>(1)</sup>	316 SST with Tantalum Sheath	
V	310 SST	
W	321 SST	
X	Special Material	
Y	316Ti SST	
Z	Chrome Molybdenum Grade F11	

**Table 18. Series 91 Thermowells**

★ The Standard offering represents the most common options. The starred options (★) should be selected for best delivery lead time. The Expanded offering is subject to additional delivery lead time.

<b>Immersion length (U)<sup>(2)</sup></b>		
005 <sup>(3)(4)</sup>	0.5-in.	★
007 <sup>(3)(4)</sup>	0.75-in.	★
010 <sup>(3)(4)</sup>	1.0-in.	★
015 <sup>(3)</sup>	1.5-in.	★
020 <sup>(3)</sup>	2.0-in.	★
025 <sup>(3)</sup>	2.5-in.	★
030	3.0-in.	★
035	3.5-in.	★
040	4.0-in.	★
045	4.5-in.	★
050	5.0-in.	★
055	5.5-in.	★
060	6.0-in.	★
065	6.5-in.	★
070	7.0-in.	★
075	7.5-in.	★
080	8.0-in.	★
085	8.5-in.	★
090	9.0-in.	★
095	9.5-in.	★
100	10.0-in.	★
105	10.5-in.	★
110	11.0-in.	★
115	11.5-in.	★
120	12.0-in.	★
125	12.5-in.	★
130	13.0-in.	★
135	13.5-in.	★
140	14.0-in.	★
145	14.5-in.	★
150	15.0-in.	★
155	15.5-in.	★
160	16.0-in.	★
165	16.5-in.	★
170	17.0-in.	★
175	17.5-in.	★
180	18.0-in.	★

**Table 18. Series 91 Thermowells**

★ The Standard offering represents the most common options. The starred options (★) should be selected for best delivery lead time. The Expanded offering is subject to additional delivery lead time.

Immersion length (U) <sup>(2)</sup>		
185	18.5-in.	★
190	19.0-in.	★
195	19.5-in.	★
200	20.0-in.	★
205	20.5-in.	★
210	21.0-in.	★
215	21.5-in.	★
220	22.0-in.	★
225	22.5-in.	★
230	23.0-in.	★
240	24.0-in.	★
250	25.0-in.	★
260	26.0-in.	★
270	27.0-in.	★
280	28.0-in.	★
290	29.0-in.	★
300	30.0-in.	★
310	31.0-in.	★
320	32.0-in.	★
330	33.0-in.	★
340	34.0-in.	★
350	35.0-in.	★
360	36.0-in.	★
370	37.0-in.	★
380	38.0-in.	★
390	39.0-in.	★
400	40.0-in.	★
410	41.0-in.	★
420	42.0-in.	★
430	43.0-in.	★
440	44.0-in.	★
450	45.0-in.	★
460	46.0-in.	★
470	47.0-in.	★
480	48.0-in.	★

**Table 18. Series 91 Thermowells**

★ The Standard offering represents the most common options. The starred options (★) should be selected for best delivery lead time.

The Expanded offering is subject to additional delivery lead time.

Thermowell mounting style		Stem style	Tip diameter (A)	Root diameter (B)	
T20	Thread, 1/2-14 ANPT	Stepped	0.50-in.	0.63-in.	★
T22	Thread, 3/4-14 ANPT	Stepped	0.50-in.	0.75-in.	★
T24	Thread, 1-11.5 ANPT	Stepped	0.50-in.	0.88-in.	★
T26	Thread, 3/4-14 ANPT	Tapered	0.63-in.	0.88-in.	★
T28	Thread, 1-11.5 ANPT	Tapered	0.63-in.	1.06-in.	★
T30	Thread, 1 1/2-11.5 ANPT	Tapered	0.75-in.	1.50-in.	★
T32	Thread, 1/2-14 ANPT	Straight	0.50-in.	0.50-in.	★
T34	Thread, 3/4-14 ANPT	Straight	0.75-in.	0.75-in.	★
T36	Thread, 1-11.5 ANPT	Straight	0.75-in.	0.75-in.	★
T38	Thread, 3/4-14 ANPT	Straight	0.50-in.	0.50-in.	★
T44	Thread, 1/2-14 ANPT	Tapered	0.50-in.	0.63-in.	★
W38	Weld, 3/4-in. Pipe	Stepped	0.50-in.	0.75-in.	★
W40	Weld, 1-in. Pipe	Stepped	0.50-in.	0.88-in.	★
W42	Weld, 3/4-in. Pipe	Tapered	0.63-in.	0.82-in.	★
W44	Weld, 1-in. Pipe	Tapered	0.75-in.	1.00-in.	★
W46	Weld, 1 1/4-in. Pipe	Tapered	0.75-in.	1.25-in.	★
W48	Weld, 3/4-in. Pipe	Straight	0.75-in.	0.75-in.	★
W50	Weld, 1-in. Pipe	Straight	0.75-in.	0.75-in.	★
F10	Flange, F = 2-in., Class 150	Straight	0.75-in.	0.75-in.	★
F12	Flange, F = 3-in., Class 150	Straight	0.75-in.	0.75-in.	★
F52 <sup>(5)</sup>	Flange, F = 1-in., Class 150	Stepped	0.50-in.	0.75-in.	★
F54	Flange, F = 1 1/2-in., Class 150	Stepped	0.50-in.	0.75-in.	★
F56	Flange, F = 2-in., Class 150	Stepped	0.50-in.	0.75-in.	★
F58 <sup>(6)</sup>	Flange, F = 1-in., Class 150	Tapered	0.75-in.	1.00-in.	★
F60	Flange, F = 1 1/2-in., Class 150	Tapered	0.75-in.	1.00-in.	★
F62	Flange, F = 2-in., Class 150	Tapered	0.75-in.	1.25-in.	★
F64 <sup>(5)</sup>	Flange, F = 1-in., Class 150	Straight	0.75-in.	0.75-in.	★
F66	Flange, F = 1 1/2-in., Class 150	Straight	0.75-in.	0.75-in.	★
F70 <sup>(5)</sup>	Flange, F = 1-in., Class 300	Stepped	0.50-in.	0.75-in.	★
F72	Flange, F = 1 1/2-in., Class 300	Stepped	0.50-in.	0.75-in.	★
F74	Flange, F = 2-in., Class 300	Stepped	0.50-in.	0.75-in.	★
F76 <sup>(6)</sup>	Flange, F = 1-in., Class 300	Tapered	0.75-in.	1.00-in.	★
F78	Flange, F = 1 1/2-in., Class 300	Tapered	0.75-in.	1.00-in.	★
F80	Flange, F = 2-in., Class 300	Tapered	0.75-in.	1.25-in.	★
F82 <sup>(5)</sup>	Flange, F = 1-in., Class 300	Straight	0.75-in.	0.75-in.	★
F84	Flange, F = 1 1/2-in., Class 300	Straight	0.75-in.	0.75-in.	★
F86	Flange, F = 2-in., Class 300	Straight	0.75-in.	0.75-in.	★

**Table 18. Series 91 Thermowells**

★ The Standard offering represents the most common options. The starred options (★) should be selected for best delivery lead time. The Expanded offering is subject to additional delivery lead time.

Thermowell mounting style		Stem style	Tip diameter (A)	Root diameter (B)	
F88 <sup>(6)</sup>	Flange, F = 1-in., Class 600	Stepped	0.50-in.	0.75-in.	★
F90 <sup>(7)</sup>	Flange, F = 1½-in., Class 600	Stepped	0.50-in.	0.75-in.	★
F92 <sup>(7)</sup>	Flange, F = 2-in., Class 600	Stepped	0.50-in.	0.75-in.	★
F94 <sup>(5)(7)</sup>	Flange, F = 1-in., Class 600	Tapered	0.75-in.	1.00-in.	★
F96 <sup>(7)</sup>	Flange, F = 1½-in., Class 600	Tapered	0.75-in.	1.00-in.	★
F98 <sup>(7)</sup>	Flange, F = 2-in., Class 600	Tapered	0.75-in.	1.25-in.	★
F02 <sup>(5)(7)</sup>	Flange, F = 1-in., Class 600	Straight	0.75-in.	0.75-in.	★
F04 <sup>(7)</sup>	Flange, F = 1½-in., Class 600	Straight	0.75-in.	0.75-in.	★
F06 <sup>(7)</sup>	Flange, F = 2-in., Class 600	Straight	0.75-in.	0.75-in.	★
F16 <sup>(7)</sup>	Flange, F = 1½-in., Class 900	Tapered	0.75-in.	1.00-in.	★
F34 <sup>(7)</sup>	Flange, F = 1½-in., Class 1500	Tapered	0.75-in.	1.00-in.	★
F24 <sup>(7)</sup>	Flange, F = 2-in., Class 1500	Tapered	0.75-in.	1.25-in.	★
F08 <sup>(8)</sup>	Flange, F = 1½-in., Class 2500	Tapered	0.75-in.	1.00-in.	★
Q02 <sup>(9)</sup>	Sanitary, 1-in., Tri-Clamp	Stepped	0.50-in.	0.75-in.	★
Q04 <sup>(9)</sup>	Sanitary, 1½-in., Tri-Clamp	Stepped	0.50-in.	0.75-in.	★
Q06 <sup>(9)</sup>	Sanitary, 2-in., Tri-Clamp	Stepped	0.50-in.	0.75-in.	★
Q08 <sup>(9)</sup>	Sanitary, 3-in., Tri-Clamp	Stepped	0.50-in.	0.75-in.	★
Q20 <sup>(9)</sup>	Sanitary, ¾-in., Tri-Clamp	Straight	0.44-in.	0.44-in.	★
Q22 <sup>(9)</sup>	Sanitary, 1-in., Tri-Clamp	Straight	0.50-in.	0.50-in.	★
Q24 <sup>(9)</sup>	Sanitary, 1½-in., Tri-Clamp	Straight	0.50-in.	0.50-in.	★
Q26 <sup>(9)</sup>	Sanitary, 2-in., Tri-Clamp	Straight	0.50-in.	0.50-in.	★
Q28 <sup>(9)</sup>	Sanitary, 3-in., Tri-Clamp	Straight	0.50-in.	0.50-in.	★
Thermowell lagging length (T)					
T000	0.0-in.				★
T005	0.5-in.				★
T010	1.0-in.				★
T015	1.5-in.				★
T020	2.0-in.				★
T025	2.5-in.				★
T030	3.0-in.				★
T035	3.5-in.				★
T040	4.0-in.				★
T045	4.5-in.				★
T050	5.0-in.				★
T055	5.5-in.				★
T060	6.0-in.				★
T065	6.5-in.				★

**Table 18. Series 91 Thermowells**

★ The Standard offering represents the most common options. The starred options (★) should be selected for best delivery lead time. The Expanded offering is subject to additional delivery lead time.

<b>Thermowell lagging length (T)</b>		
T070	7.0-in.	★
T075	7.5-in.	★
T080	8.0-in.	★
T085	8.5-in.	★
T090	9.0-in.	★
T095	9.5-in.	★
<b>Instrument connection thread</b>		
P	1/2-14 NPSM	★
D	1/2-14 ANPT	★

### Options (include with selected model number)

<b>External pressure test</b>		
R01 <sup>(10)</sup>	External Pressure Test	★
<b>Material certification</b>		
Q8	Material Certification	★
<b>Dye penetration test</b>		
R03	Dye Penetration Test	★
<b>Thermowell special cleaning</b>		
R04	Thermowell Special Cleaning	★
<b>NACE approval</b>		
R05	NACE Approval	★
<b>SST plug and chain</b>		
R06	SST Plug and Chain	★
<b>Full penetration weld</b>		
R07 <sup>(11)</sup>	Full Penetration Weld	★
<b>Thermowell concentric serrations</b>		
R09 <sup>(11)(12)</sup>	Concentric Serration of Thermowell Flange Face	★
<b>Flat faced flange</b>		
R10 <sup>(11)(12)</sup>	Flat Face Flange	★
<b>Vent hole</b>		
R11	Vent Hole	★
<b>Special surface finish</b>		
R14	Thermowell Special Surface Finish (12 R <sub>a</sub> Max) (Maximum (U) Length = 22.5-in.)	★

**Table 18. Series 91 Thermowells**

★ The Standard offering represents the most common options. The starred options (★) should be selected for best delivery lead time. The Expanded offering is subject to additional delivery lead time.

<b>Ring joint flange</b>		
R16 <sup>(11)(12)</sup>	Ring Joint Flange (not available with 0-in. [T] Length)	★
<b>Electropolish</b>		
R20 <sup>(13)</sup>	Electropolish	★
<b>Wake frequency</b>		
R21	Wake Frequency Calculation	★
<b>Internal pressure test</b>		
R22	Internal Pressure Test	★
<b>Brass plug and chain</b>		
R23	Brass plug and chain	★
<b>Canadian registration no.</b>		
R24	CRN Marking for British Columbia	
R25	CRN Marking for Alberta	
R26	CRN Marking for Saskatchewan	
R27	CRN Marking for Manitoba	
R28	CRN Marking for Ontario	
R29	CRN Marking for Quebec	
R30	CRN Marking for New Brunswick	
R31	CRN Marking for Nova Scotia	
R32	CRN Marking for Prince Edward Island	
R33	CRN Marking for Yukon Territory	
R34	CRN Marking for Northwest Territory	
R35	CRN Marking for Nunavut	
R36	CRN Marking for Newfoundland and Labrador	
<b>Twell from hex stock</b>		
R37	Thermowell from Hex stock	

(1) Available only in straight stem flanged thermowells.

(2) Thermowells with an overall lengths ("U" + "T" + 1.75-in.) of 36-in. or less are machined from solid bar stock. Thermowells with an overall length larger than 42-in. will be constructed using a welded 3-piece design and are available only with a stepped stem style. For lengths between 36-in. and 42-in. consult factory for construction method.

(3) Available only in straight or Tapered stem only.

(4) Only available with Thermowell Mounting Style Q20.

(5) F52, F64, F70, F82, F88 and F02 are not compatible with 1-in. Sch. XXS pipe.

(6) F58, F76 and F94 may not be compatible with 1-in. Sch. pipe and are not compatible with 1-in. Sch. 80, 160 or XXS pipe.

(7) These options cannot be used with 0-in. (T) length.

- (8) F08 cannot be used with 0- or  $\frac{1}{2}$ -in. (T) length.
- (9) Limited to 24-in. immersion length and 316 or 304 SST materials only.
- (10) Maximum (U) length = 42.0-in.
- (11) Available on flanged thermowells only.
- (12) Only one flange face option allowed.
- (13) Not available on flanged thermowells and L lengths longer than 24-in.

**Table 19. Sensor Series and Dimensions**

Series	Housing diameter	# of lead wires	Lead wire length
68	0.350 (8)	4	6.0 (152.4)
78 single	0.350 (8)	4	6.0 (152.4)
78 dual	0.350 (8)	6	6.0 (152.4)
183 single	0.375 (9.53)	2	6.0 (152.4)
183 dual	0.375 (9.53)	4	12.0 (304.8)



# Introduction

## Overview

Emerson Process Management offers a wide variety of RTD and thermocouple sensors that are available alone or as complete assemblies including connection heads, thermowells, and extension fittings. In addition to complete assemblies, Emerson Process Management offers heads, coupling/nipple and union/nipple extensions, compression fittings, and thermowells.

### Using this Product Data Sheet (PDS)

Use this PDS to order complete temperature sensor assemblies, which include sensors, thermowells, extensions, and connection heads. These options can also be ordered separately. For example, you can order a thermowell, extension, or connection head for use with an existing sensor. In each case it is important to know and understand the sections of this PDS when specifying the items.

#### Threaded sensors and assemblies

- Includes descriptions, specifications, and ordering information for Series 58C, 68, 68Q, and 78 RTDs, and the Series 183 Thermocouples.
- Includes information for ordering sensors, connection heads, extensions, and thermowells as complete assemblies.

#### Calibration

- Includes characterization schedules and information for ordering calibrated Series 68, 68Q, and 78 RTD Sensors.
- Includes information regarding the use of Callendar-Van Dusen constants to match specific Series 68, 68Q, and 78 RTDs to Rosemount Smart Temperature Transmitters.

#### Sensor accessories

- Includes descriptions, specifications, and ordering information for temperature accessories such as thermowells, extensions, connection heads, mounting adapters, lead wire extensions, connectors, and thermowells.

#### Hazardous area approvals

- Includes descriptions of the FM, CSA, IECEx, and ATEX approvals for sensors and connection heads.

#### Configuration data sheet

- Provides a form used for thermowell application calculations.

#### RTD

Series 58C, 68, 68Q, and 78 Platinum RTD Temperature Sensors are primarily used when high accuracy, durability, and long-term stability are required. These sensors conform to international standards: IEC 751:1983, Amendments 1&2.<sup>(1)</sup>

##### Series 58C Platinum RTD Temperature Sensors

- Combine an economical thin-film design with a sheath that can be shortened to any length with tubing cutter.

##### Series 68Q Quick Response Sanitary RTD Sensors

- Conform to 3-A Sanitary Standards and feature product contact surfaces designed for CIP cleaning.

##### Series 68 Platinum RTD Temperature Sensors

- Provide high performance in an economical thin-film design.

##### Series 78 Platinum RTDs Temperature Sensors

- Use a wire-wound element which allows for a broader measurement range.

#### Thermocouples

Series 183 Thermocouple Temperature Sensors conform to ASTM E-230, and are available in types J, K, E, and T.

Series 183 Thermocouple Temperature Sensors are available:

- Grounded or ungrounded
- Isolated or unisolated
- With immersion lengths from 2-in. to 48-in.

(1) 100 ohms at 0 °C,  $\alpha = 0.00385 \text{ ohms/ohm/}^\circ\text{C}$ .

## The use of 2-, 3-, and 4- wire RTDs

To help you attain the highest possible temperature measurement accuracy, Rosemount provides 4-wire sensors for all single element RTDs. You can use these RTDs in 2-, 3-, or 4-wire configurations by simply securing the unneeded leads with tape. To properly wire the 4-wire RTD for use in a 2-, 3-, or 4-wire configuration, refer to the following wiring diagrams:

### 2-wire configuration

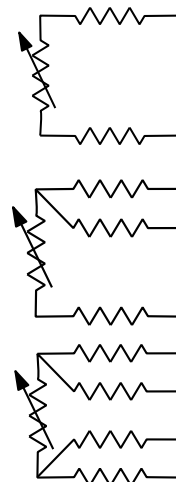
2-wire RTDs provide one connection to each end of the sensor. In a 2-wire configuration, lead wires add resistance to the circuit which cannot be compensated. The 2-wire configuration is rarely used because the added lead wire resistance can cause substantial errors in the temperature reading.

### 3-wire configuration

3-wire RTDs provide one connection to one end of the sensor, and two connections to the other end. The 3-wire approach does not eliminate all lead wire effects. However, for sensors with lead wires of the same length, lead wire effects are slight, and the approach provides reasonable accuracy.

### 4-wire configuration

The most effective way to eliminate lead wire effects is with two connections at each end of the sensor. 4-wire RTDs fully compensate for lead wire effects.



## Benefits and limitations of RTDs when compared to Thermocouples

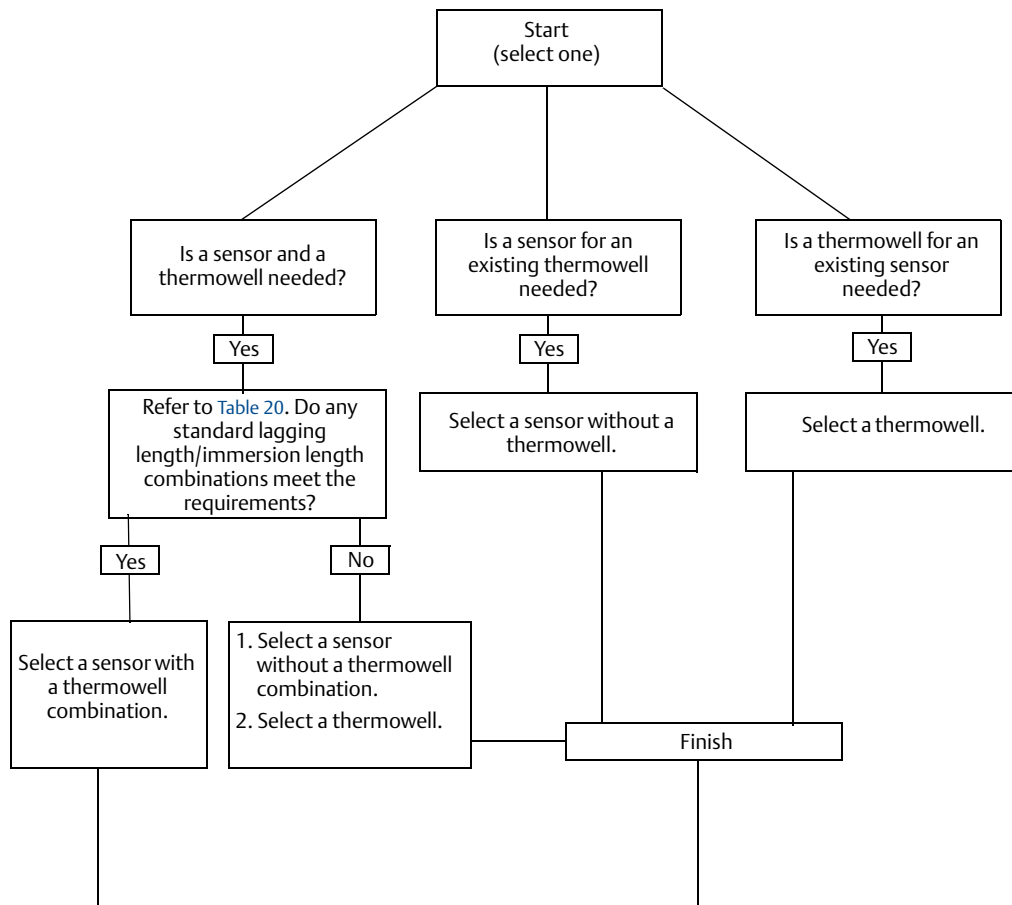
### Benefits

- Higher accuracy
- Better linearity and long-term stability
- Cold junction compensation not required
- Special extension lead wire not required
- Less susceptible to noise
- Can be “matched” to a Rosemount transmitter with transmitter sensor matching

### Limitations

- Lower maximum temperature limit
- Slower response time in applications without a thermowell
- Reduced resistance to vibration-induced failure

## How to Decide What to Order



### Model code visible

If Rosemount sensor and model code is visible on the sensor:

1. If the thermowell is ordered separately  
(0078P23C30N060) 11th digit = 'N'
  - a. Start with immersion length - digits 12-14; 060 = 6.0 in.
  - b. Add extension length - digits 9 & 10; 30 = 3.0 in. (3 + 6 = 9)
  - c. Order the replacement sensor for the total length without connection heads (5th digit N) and extension (8th digit N)  
0078N23N00N090.
2. If the thermowell is ordered integral to sensor  
(0078P23C30A060W40) 11th digit = not 'N'
  - a. Immersion length 'U' is defined by the 12-14th digits; 060 = 6.0 in.
  - b. Look up 'L' length from the correct order chart for given 'U' length. This will be 4 inches for short sensors, or a whole number divisible by 3 for sensors longer than 4 inches (4, 6, 9, 12, 15, 18... inches);  
'U' 060 = 9 inches 'L'.
  - c. Add extension length as defined by 9th and 10th digits; 30 = 3.0 in. to the 'L' length found in table.  
(9" + 3" = 12", Length code 120).
  - d. This will be the replacement sensor length 'X'.
  - e. Order sensor without connection head (5th digit N) or extension (8th digit N) 0078N23N00N120.

## Model code not visible

If model code is NOT visible on the sensor, follow one of three steps below.

1. Measure the inside depth of the thermowell.
  - a. Measure down the inside of the thermowell hole to the top-most face of the extension used, or the thermowell if no extension.
  - b. This will be the replacement sensor length if depth = 12.0 in., sensor length will be 12 in.
  - c. Order sensor without connection heads (5th digit N) or extension (8th digit N) 0078N23N00N120.
2. Measure the overall outside length of the thermowell from end to end.
  - a. Measure down the outside of the thermowell from the tip to the end face of the extension if used, or the thermowell if no extension.
  - b. Subtract  $\frac{1}{4}$  in. to account for thickness of the thermowell at the tip.
  - c. This will be the replacement sensor length. Overall length = 12.25 in., the replacement will be 12 in.
  - d. Order sensor without connection heads (5th digit N) or extension (8th digit N) 0078N23N00N120.
3. Measure the old sensor length from tip to the flat face of the threaded process connection.
  - a. Determine if the sensor is spring loaded or general purpose (welded) where the sensor sheath meets the threaded adapter.
  - b. For spring loaded sensors, the measurement of the exposed sheath from tip of the start of the threaded portion will be the same as the replacement sensor length.
    - Normal spring compression for a Rosemount sensor is assumed to be  $\frac{1}{2}$  in. and the normal thread engagement is also assumed to be  $\frac{1}{2}$  in.
    - Round to the nearest whole  $\frac{1}{4}$  in. increment as the spring will make up any small differences.
    - Replacement sensor for a spring loaded sensor measuring 6.5 inches will be 6.5 in. length.
  - c. Order sensor without connection heads (5th digit N) or extension (8th digit N) 0078N15N00N065.
  - d. For general purpose sensors with the distance from tip to threaded adapter:
    - Add  $\frac{1}{4}$  in. to allow clearance, preventing bottoming sensor during installation.
    - Add  $\frac{1}{2}$  in. for the thread engagement of the sensor in the thermowell.
    - The replacement sensor for a general purpose sensor measuring 5.75 in. from the tip to the threaded adapter is 6.5 in. ( $5\frac{3}{4} + \frac{1}{4} + \frac{1}{2} = 6\frac{1}{2}$  in).
  - e. Order sensor without connection heads (5th digit N) or extension (8th digit N) 0078N15N00N065.

## Model code on thermowell

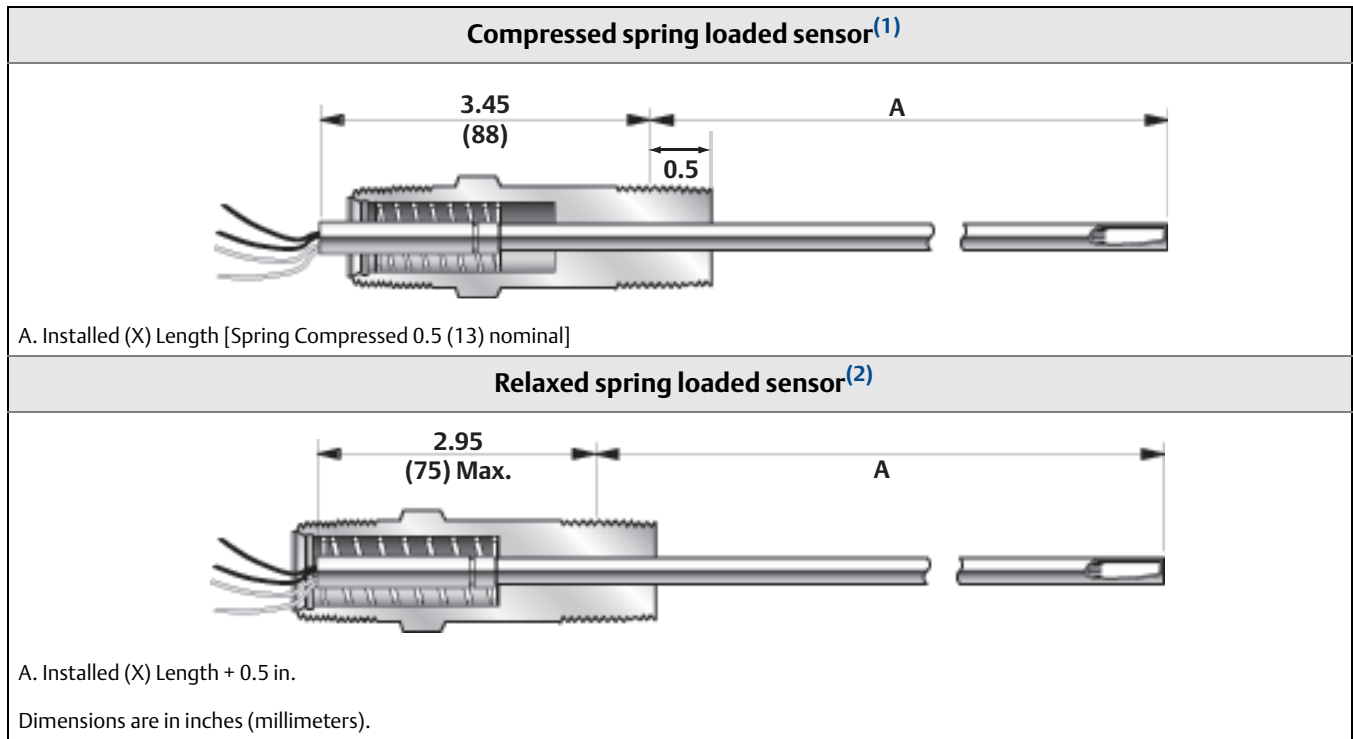
If model code is visible on the thermowell (0091A060W40T015P), follow the instructions below to determine sensor model number.

1. Start with immersion length digits 6-8, 060 = 6.0 in.
  - a. Add additional lagging length digits 13-15, 015 = 1.5 in.
  - b. To those lengths add 1.5 in. (this is the additional standard lagging length on all Rosemount thermowells) 1.75 in. minus (0.25 in. thermowell tip thickness) = 1.50 in.
  - c.  $6.0 + 1.5 + 1.5 = 9$  in.
  - d. Order replacement sensor 0078N23N00N090.

# Spring-Loaded Sensor Dimensions

When a spring-loaded sensor is used properly, the spring should be compressed approximately 1/2-inch. Therefore, all measurements of spring-loaded sensors are made with the spring compressed. If you measure an existing spring-loaded sensor while it is in a relaxed state, you must subtract 1/2-inch to arrive at the installed length (X) that must be ordered. See Figure 1.

**Figure 1. Spring Loaded Sensor Dimensions**



- (1) Spring loaded sensor in a compressed state: The actual sensor length is measured when the spring is compressed approximately 1/2-in. shorter than the relaxed sensor.
- (2) Spring loaded sensor in a relaxed state: Normally, when a spring loaded sensor is measured, it is in a relaxed state. You must subtract 1/2-in. from your measurement to order a replacement sensor. Rosemount Inc. assumes that the sensor length you specify is that of a compressed sensor.

## Determining the length (L) of a spring-loaded sensor to be used with an existing non-Rosemount Thermowell

(see Figure 1, Figure 3, and Figure 4).

1. Remove the existing sensor from the installed thermowell.
2. Measure the sensor length with the spring in the relaxed state (as shown in Figure 1). Measure from the tip of the sensor to the maximum thread engagement point (0.53-in. into the threads).
3. Subtract 0.5-in. from your measurement. The resulting length is (X).
4. If the sensor is installed with an extension, measure the extension length (E), as shown in Figure 4. If the sensor is not installed with an extension, let (E) = 0.
5. Since  $(X) = (E) + (L)$ , subtract (E) from (X) to find (L).
6. Use the resulting length (L) in the Section 2 ordering tables to choose the correct length of sensor.

Length code key	
L	Thermowell length minus tip thickness
U	Thermowell Immersion length into process
T	Thermowell Lagging length
E	Extension fitting length
X	Sensor length

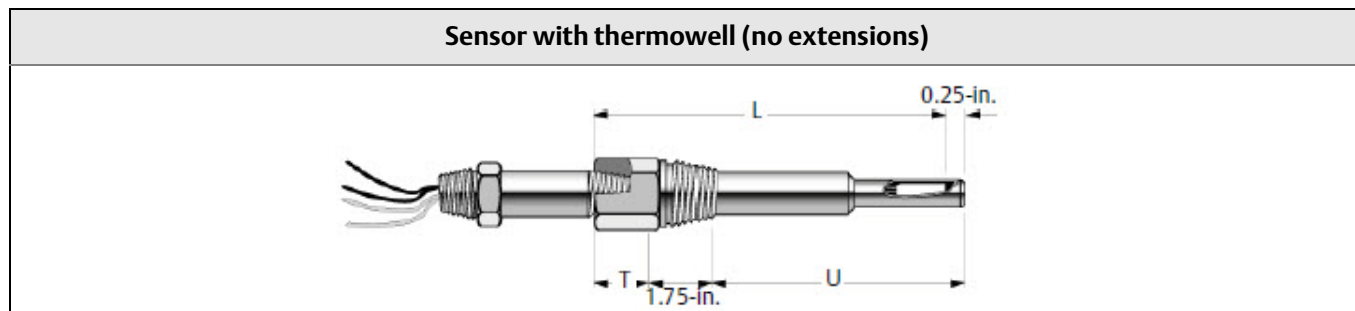
Use the following equations to determine all lengths:

$$L = U + T + 1.5$$

$$X = E + L$$

$$X = E + U + T + 1.5$$

**Figure 2. Thermowell Dimensions (use with Sensor Ordering Tables)**



1. Determine the (U), (T), and (E) lengths necessary for your installation.  
If you do not need an extension, (E) = 0 (zero).  
Note: If your existing sensor/thermowell combination is different than Figure 2, refer to the drawings on the following pages.
2. Find your immersion length (U) on Table 20 and compare the corresponding lagging length (T) to the lagging length that you previously determined.
3. If your lengths match the values on the line that corresponds to your required immersion length, order your sensor and thermowell together.
4. If your lengths do not match the values on the line that corresponds to your measured immersion length, order your sensor and thermowell separately. Solve for (L) using the equation  $(L) = (U) + (T) + 1.5$  (since (L) is required when ordering the sensor separately from the thermowell).

Length code key	
L	Thermowell length minus tip thickness
U	Immersion length into process
T	Lagging length
E	Extension fitting length
X	Sensor length

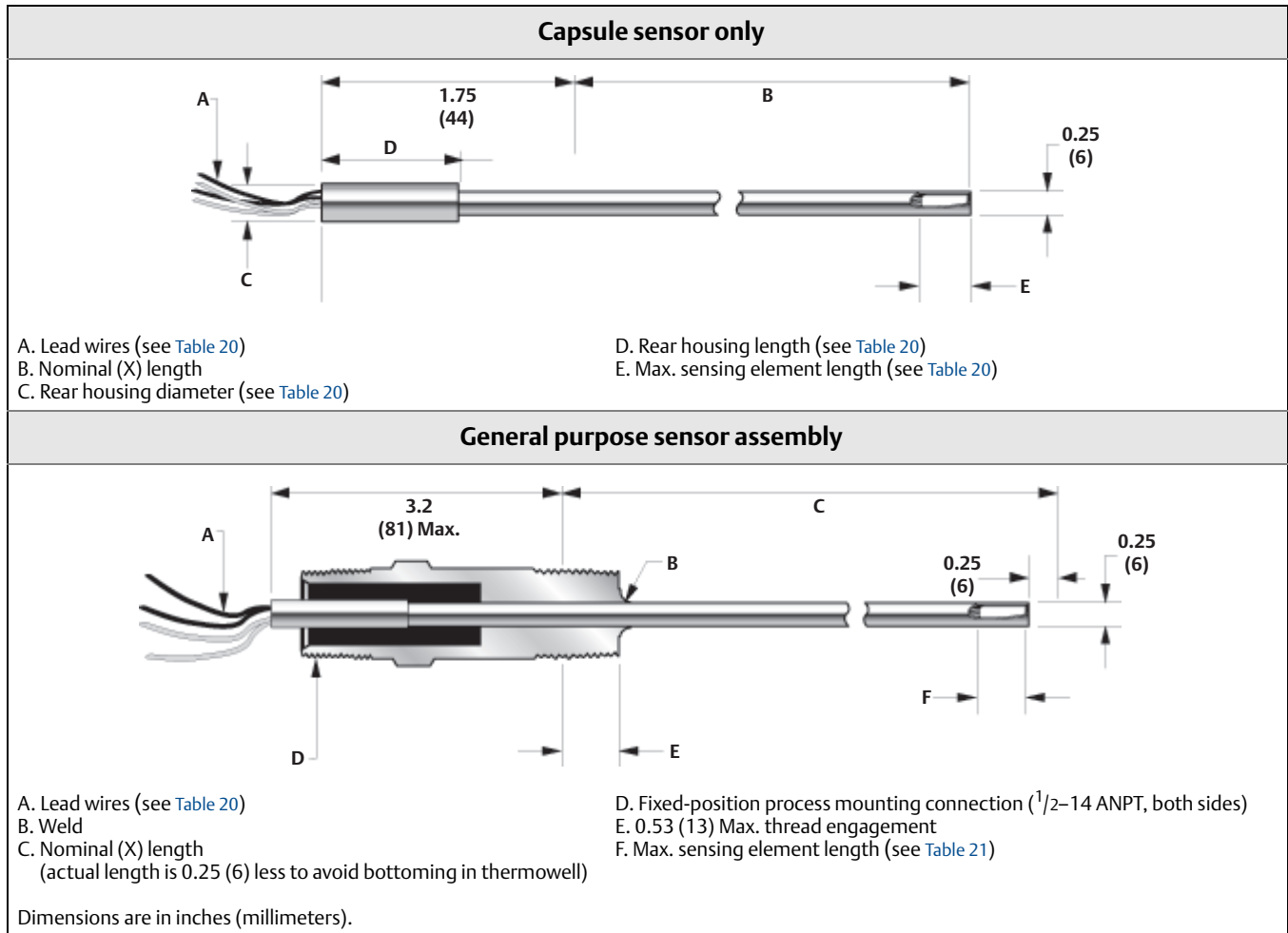
Use the following equations to determine all lengths:

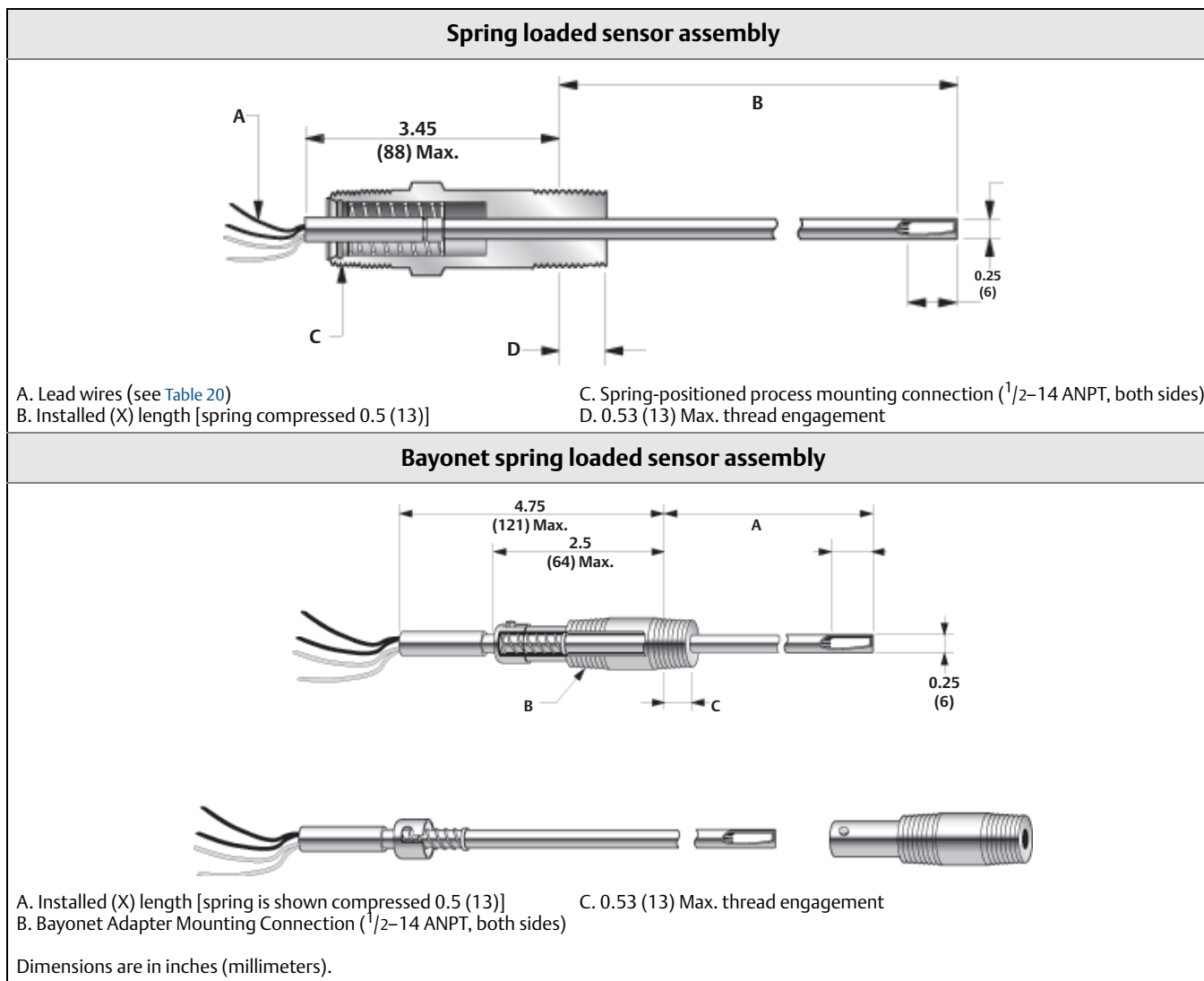
$$L = U + T + 1.5$$

$$X = E + L$$

$$X = E + U + T + 1.5$$

Figure 3. Series 68, 78, and 183 Sensor Assembly Dimensional Drawings



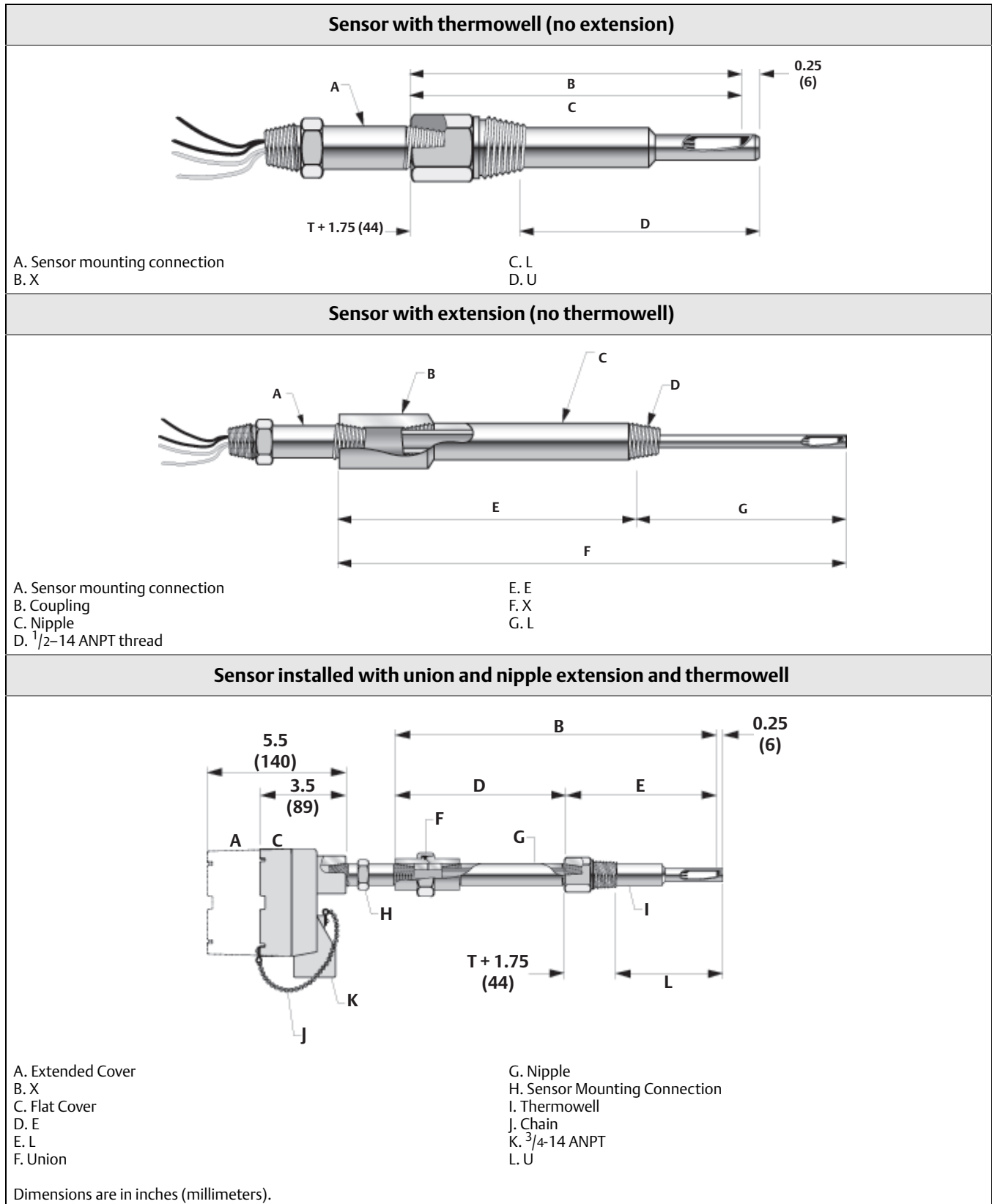


**Table 20. Sensor Series and Dimensions**

Series	Rear housing diameter	Rear housing length	Max. sensing element length	# of lead wires	Lead wire length
68	0.25 (6)	0.5 (13)	0.9 (23)	4	6.0 (152)
78 Single	0.34 (9)	1.32 (34)	0.6 (15)	4	6.0 (152)
78 Dual	0.34 (9)	1.32 (34)	1.0 (25)	6	6.0 (152)
78 High Temp	0.25 (6)	0.5 (13)	1.85 (47)	4	6.0 (152)
183 Single	0.375 (9.5)	1.25 (32)	0.25 (6)	2	6.5 (165)
183 Dual	0.375 (9.5)	1.25 (32)	0.5 (13)	4	6.5 (165)



Figure 4. Series 68, 78, and 183 Sensor Assembly Length Code Drawings

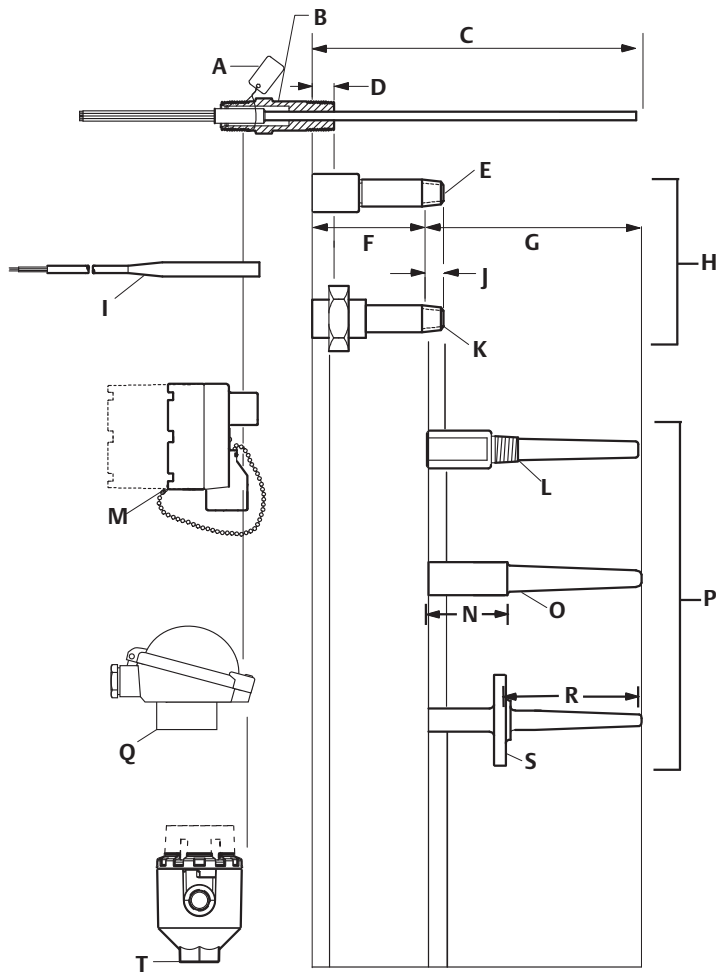


## Temperature Sensor Assemblies

Series 68, 68Q, and 78 RTD and Series 183 Thermocouple Sensors may be ordered as complete assemblies. These assemblies provide a complete, yet simple means of specifying the proper industrial hardware for most temperature measurements.

One assembly model number, derived from one ordering table, completely defines the type of sensing element, as well as the material, length, and style of both the extension fittings and thermowells. All sensor assemblies are sized and inspected by Emerson Process Management to ensure complete component compatibility and performance.

**Figure 5. Individual Components of a Complete Temperature Assembly**



- |                                     |  |
|-------------------------------------|--|
| A. Optional identification tag      | K. Union-nipple  |
| B. Standard adapter sensor assembly | L. Threaded  |
| C. Length "X"                       | M. Aluminum connection heads (with flat or extended cover)                       |
| D. 0.5 (13) nominal engagement      | N. T + 1.75  |
| E. Coupling-nipple                  | O. Welded  |
| F. Length "E"                       | P. Thermowells   |
| G. Length "L"                       | Q. Polypropylene connection head   |
| H. Extensions                       | R. Length "U"  |
| I. Lead wire extensions and seals   | S. Flanged   |
| J. 0.5 (13) nominal engagement      | T. Rosemount aluminum connection head (with standard or LCD display meter cover) |

Dimensions are in inches (millimeters).

## Mounting configurations

### Capsule

Capsules are designed for direct immersion without mounting fittings. Accessory compression fittings are available for adjustable mounting into a thermowell. See [Mounting adapters for Series 58, 68, 78, and 183](#).

### General-purpose sensor assemblies

Designed with a welded, fixed-position, 1/2-14 ANPT process connection fitting for direct immersion or thermowell applications. This sensor design provides a moisture-proof and vapor-tight seal. The maximum static working pressure at 20 °C (68 °F) with no vibration or flow condition is 24.13 MPa (3,500 psig). The use of a thermowell is recommended for process pressure containment. Note that standard lengths are 1/4-inch less than nominal dimension to prevent bottoming of the sensor in a thermowell.

### Spring-loaded sensor assemblies

Spring-loaded sensors have a spring-positioned, 1/2-14 ANPT process connection fitting that ensures good surface contact in thermowells for faster time response and vibration resistance. Spring-loaded sensors are not intended to provide a process seal. They must be used in conjunction with a thermowell for this purpose.

#### Note

When a spring-loaded sensor is used properly, the spring should be compressed approximately 1/2 inch.

### Bayonet spring-loaded sensor assemblies

Bayonet assemblies have the same advantages as the spring-loaded sensor. However, the bayonet connector permits the sensor to be easily removed from the process without tools.

**Figure 6. Series 68, 68Q, 78, and 58C Lead Wire Configurations**

Single element	Dual element <sup>(1)</sup>

(1) Dual element sensors are only available on Series 68Q and 78 Sensors.

## Series 68 Platinum RTD

Rosemount Series 68 Platinum Resistance Temperature Sensors measure from  $-50$  to  $400$  °C ( $-58$  to  $752$  °F). Series 68 Class B, Pt100-385 sensors are available in capsule, general purpose, and spring-loaded designs in sensor lengths from 1 to 48 inches.

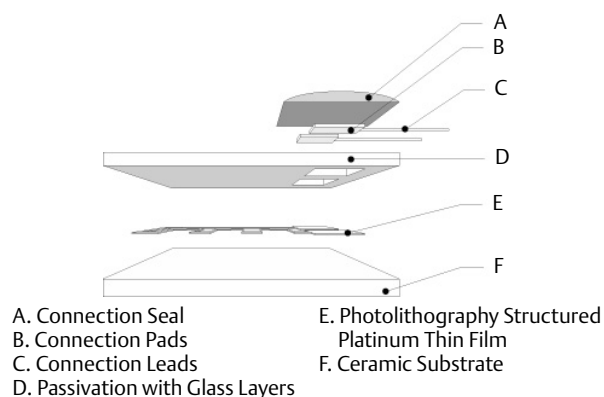
Table 21 shows the interchangeability of the Series 68 RTD. As an option, for maximum system accuracy, Emerson Process Management can provide sensor calibration. See [Sensor characterization \(calibration\) schedules– Option Code V](#). In addition, Emerson Process Management offers optional sensor-to-transmitter matching capability obtainable through the use of Callendar-Van Dusen Constants. See [Option Code “V” Callendar-van Dusen Constants](#).

**Table 21. Series 68 Interchangeability**

$\pm 0.55$ °C ( $\pm 0.99$ °F) at $-50$ °C ( $-58$ °F)
$\pm 0.30$ °C ( $\pm 0.54$ °F) at $0$ °C ( $32$ °F)
$\pm 0.80$ °C ( $\pm 1.44$ °F) at $100$ °C ( $212$ °F)
$\pm 1.30$ °C ( $\pm 2.34$ °F) at $200$ °C ( $392$ °F)
$\pm 1.80$ °C ( $\pm 3.24$ °F) at $300$ °C ( $572$ °F)
$\pm 2.30$ °C ( $\pm 4.14$ °F) at $400$ °C ( $752$ °F)

## Construction

**Figure 7. Construction of a Platinum Thin Film RTD**



Design and construction of the Series 68 Platinum Sensors provides the optimum combination of accuracy and durability available for temperature measurements. The construction of the sensor allows for direct immersion in non-corrosive fluids at reasonable static pressures. For corrosive environments or many industrial applications, these sensors are widely used with standard thermowell assemblies.

## Platinum element and lead wire configurations

Single-element temperature sensors have four lead wires and may be used in 2-, 3-, and 4-wire signal conditioning systems.

## Specifications

### Performance specifications

#### Temperature range

$-50$  to  $400$  °C ( $-58$  to  $752$  °F)

#### Effect of temperature cycling

$\pm 0.05\%$  ( $0.13$  °C or  $0.23$  °F) maximum ice-point resistance shift following 10 cycles over the specified temperature range

#### Stability

$\pm 0.11\%$   $0.28$  °C or  $0.51$  °F maximum ice-point resistance shift following 1,000 hours at maximum specified temperature ( $400$  °C)

#### Maximum hysteresis

$\pm 0.1\%$  of operating temperature range

#### Time constant

12 seconds maximum required to reach 63.2% sensor response in water flowing at 3 ft/s ( $0.91$  m/s)

#### Nominal R0 100 Ohm

Nominal  $\alpha$   $0.00385$   $\Omega/\Omega^{\circ}\text{C}$

## Physical specifications

### Material selection

Emerson provides a variety of Rosemount product with various product options and configurations including materials of construction that can be expected to perform well in a wide range of applications. The Rosemount product information presented is intended as a guide for the purchaser to make an appropriate selection for the application. It is the purchaser's sole responsibility to make a careful analysis of all process parameters (such as all chemical components, temperature, pressure, flow rate, abrasives, contaminants, etc.), when specifying product, materials, options and components for the particular application. Emerson Process Management is not in a position to evaluate or guarantee the compatibility of the process fluid or other process parameters with the product, options, configuration or materials of construction selected.

### Sheath material

316 SST and 321 SST

### Lead wire

PTFE insulated, silver plated, 24-gauge stranded copper wire

### Identification data

The model, serial numbers, and up to six lines of permanent tagging information are etched on each sensor adapter. Stainless steel tags are available upon request.

## Environmental specifications

### Humidity limits

Lead seal can withstand 100% relative humidity

### Vibration limits

±0.05% maximum ice-point resistance shift due to 30 minutes of 14 g peak vibration from 5 to 350 Hz at 20 °C (68 °F) for unsupported stem length of less than 6 inches

### Quality assurance

Each sensor is subjected to a resistance accuracy test at 0 °C and an insulation resistance test

### Enclosure ratings

When installed properly, Rosemount Series 68 sensors are suitable for indoor and outdoor NEMA 4X and CSA Enclosure Type 4X installations. See [Hazardous area approvals](#) for complete installation information

### Insulation resistance

1000 x 10<sup>6</sup> ohms minimum insulation resistance when measured at 500 Vdc at room temperature

## Series 78 Platinum RTD

Series 78 Sensors are intended for applications that require high accuracy, dual-elements, and/or are subjected to high temperatures. Series 78 Platinum Resistance Temperature Sensors measure from  $-200$  to  $600$  °C ( $-328$  to  $1112$  °F). These sensors are available in capsule, general-purpose, and spring-loaded in sensor (X) lengths from 1 to 68 inches. They are also available bayonet spring-loaded style in sensor (X) lengths from 1 to 45 inches.

Table shows the interchangeability of the Series 78 Pt100-385 Sensors. The performance of the standard Series 78 Sensor conforms to the standard set by IEC 751 Class B. Additionally, IEC-751 Class A accuracy is available as an option. For maximum system accuracy, Emerson Process Management can provide sensor calibration. See [Sensor characterization \(calibration\) schedules– Option Code V](#). Emerson Process Management also offers optional sensor-to-transmitter matching capability obtainable through the use of Callendar-Van Dusen Constants. See [Option Code “V” Callendar-van Dusen Constants and Graph of a Typical Two-Point Trim](#)

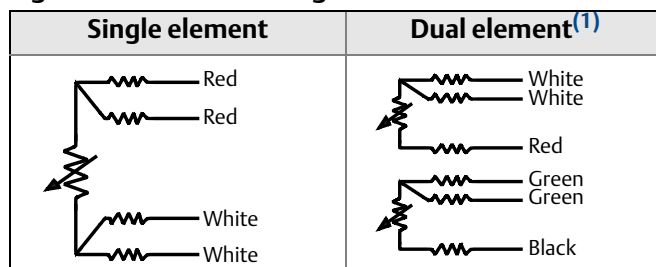
The wire-wound design and construction of the general-purpose Series 78 Sensor allows direct immersion in non-corrosive fluids at reasonable static pressures. For corrosive environments and in many industrial applications, these sensors are commonly used with standard thermowell assemblies.

### Platinum element and lead wire configurations

Single-element high-temperature sensors have four lead wires and may be used in 2-, 3-, and 4-wire signal conditioning systems.

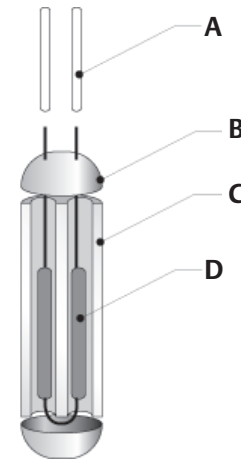
Dual-element sensors have redundant elements to provide separate readout and control signals from a single measurement point. Dual-element sensors have three lead wires for each element and may be used with 2- or 3-wire systems.

**Figure 8. Lead Wire Configuration**



(1) Dual element sensors are only available on Series 68Q and 78 Sensors.

**Figure 9. Construction of a Platinum Wire-Wound RTD**



- A. Lead Wires
- B. Seal
- C. High Purity Insulator
- D. Platinum Resistance Element

## Specifications

### Performance specifications

#### Temperature range

Series 78 single- and dual-element sensors may be used in temperatures from  $-200$  to  $500$  °C ( $-328$  to  $932$  °F). Series 78 single-element high-temperature sensors are provided for high-temperature service over the range of  $0$  to  $600$  °C ( $32$  to  $1112$  °F).

#### Effect of temperature cycling

$\pm 0.04\%$  ( $0.10$  °C or  $0.18$  °F) maximum ice-point resistance shift following 10 cycles between  $-200$  and  $500$  °C ( $-328$  to  $932$  °F).

#### Stability

$\pm 0.05\%$  maximum ice-point resistance shift following 1,000 hours at  $400$  °C ( $752$  °F).

**Table 22. Series 78 Interchangeability<sup>(1)(2)</sup>**

Standard series 78 IEC-751 Class B	Temperature
±0.80 °C (±1.44 °F)	-100 °C (-148 °F)
±0.30 °C (±0.54 °F)	0 °C (32 °F)
±0.80 °C (±1.44 °F)	100 °C (212 °F)
±1.80 °C (±3.24 °F)	300 °C (572 °F)
±2.30 °C (±4.14 °F)	400 °C (752 °F)
Series 78 with IEC-751 Class A option	Temperature
±0.35 °C (±0.63 °F)	-100 °C (-148 °F)
±0.15 °C (±0.27 °F)	0 °C (32 °F)
±0.35 °C (±0.63 °F)	100 °C (212 °F)
±0.75 °C (±1.35 °F)	300 °C (572 °F)
±0.95 °C (±1.71 °F)	400 °C (752 °F)

(1) Both tolerances valid from -200 to 500 °C.

(2) Class B tolerances valid from 0 to 600 °C on single- element high temperature sensor.

#### Maximum hysteresis

- Single- and dual-element, Nominal R0 100 Ohm Nominal alpha 0.00385 Ω/Ω °C: +/- 0.04% of range
- Single-element, high temperature: ±0.1% of range.

#### Time constant

4 seconds maximum required to reach 63.2% sensor response in water flowing at 3 ft/s (0.91 m/s), 9.5 seconds for single-element high-temperature sensors.

#### Self heating

18 mW minimum power dissipation required to cause a 1 °C (1.8 °F) temperature measurement error in water flowing at 3 ft/s, 25 mW for single-element high temperature sensors.

#### Insulation resistance

500 x 10<sup>6</sup> ohms minimum insulation resistance when measured at 500 Vdc at room temperature [20 °C (68 °F)].

## Environmental specifications

### Humidity limits

Lead seal is capable of withstanding 100% relative humidity.

### Vibration limits

#### Standard single- and dual-element sensors

- ±0.03% maximum ice-point resistance shift due to 30 minutes of 21 g peak vibration from 5 to 350 Hz continuous sweep at 20 °C (68 °F) for unsupported stem length of less than 5.5 inches (140 mm).

#### Single-element high-temperature sensors

- Meet ASTM E 1137-95. Cycling time is 3 hours per longitudinal axis, less the time spent at resonant dwells at the axis, from 5 to 500 Hz. The test level is 1.27 mm (0.05 in.) double amplitude displacement or peak g-level of 3, whichever is less.

### Quality assurance

Each sensor is subjected to a resistance accuracy test at 0 °C and an insulation resistance test.

### Enclosure ratings

When installed properly, Rosemount Series 78 Sensors are suitable for indoor and outdoor NEMA 4X and CSA Enclosure Type 4X installations. See [Hazardous area approvals](#) for complete installation information.

## Physical specifications

### Sheath material

Single and dual-element, 316 SST

Single element high temperature, 316SST and 321 SST

### Lead wires

- Single and dual-element, PTFE-insulated, nickel-coated, 22-gauge stranded copper wire.
- Single element high temperature, PTFE insulated, silver plated, 24-gauge stranded copper wire.

### Identification data

The model and serial numbers and up to six lines of permanent tagging information are etched on each sensor adapter. Stainless steel tags are available upon request.

## Series 183 Thermocouple

Rosemount Series 183 Thermocouple Sensors measure from  $-180$  to  $1150$  °C ( $-292$  to  $2102$  °F).

### Construction

The Series 183 Thermocouples are manufactured using Type J, K, E, or T wire with “special limits of error” accuracy. The junction of these wires is fusion-welded to form a pure joint, to maintain the integrity of the circuit, and to ensure the highest accuracy. Grounded junctions are available for improved response time and good thermal contact with protection from the environment. The ungrounded and isolated junctions provide electrical isolation from the sensor sheath (see Figure 10).

Rosemount thermocouples are encased in a protective metal sheath. The sheath material is 304 SST for types J, E, and T, used at temperatures up to  $871$  °C ( $1600$  °F) and Inconel for type K, used at temperatures up to  $1150$  °C ( $2102$  °F). Metallic oxide insulation is compacted into the sheath to mechanically support and electrically insulate the thermocouple wire. See Table 23 for more information on the different types of thermocouples.

Figure 10. Series 183 Junction Configurations

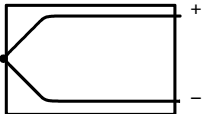
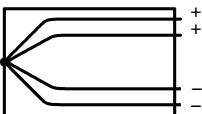
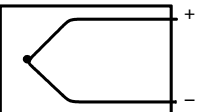
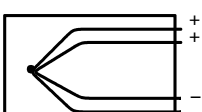
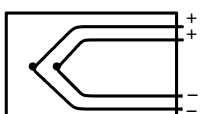
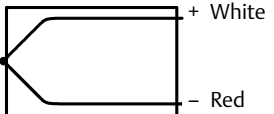
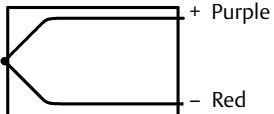
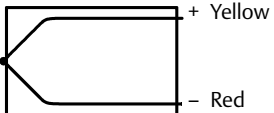
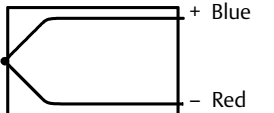
Single, grounded	Dual, grounded, unisolated
	
Single, ungrounded	Dual, ungrounded, unisolated
	
	Dual, ungrounded, isolated
	

Figure 11. Series 183 Lead Wire Configurations

Type J	Type E
	
Type K	Type T
	

### Specifications

#### Performance specifications

The thermoelectric current relationship in a thermocouple is standardized and defined by ASTM E-230. All Series 183 Thermocouples conform to these standards with “special limits of error” accuracy. The particular characteristics of each ISA type thermocouple are outlined in Table 23.

#### Physical specifications

##### Sheath material

304 SST for types J, E, and T (used at temperatures up to  $871$  °C).  
Inconel for type K (used at temperatures up to  $1150$  °C).

##### Lead wires

Thermocouple, External lead wires—20 AWG wire, PTFE-insulated. Color coded per lead wire configuration schematic shown in Figure 11.

##### Identification data

The model and serial numbers and up to six lines of permanent tagging information are etched on each sensor adapter. Stainless steel tags are available upon request.

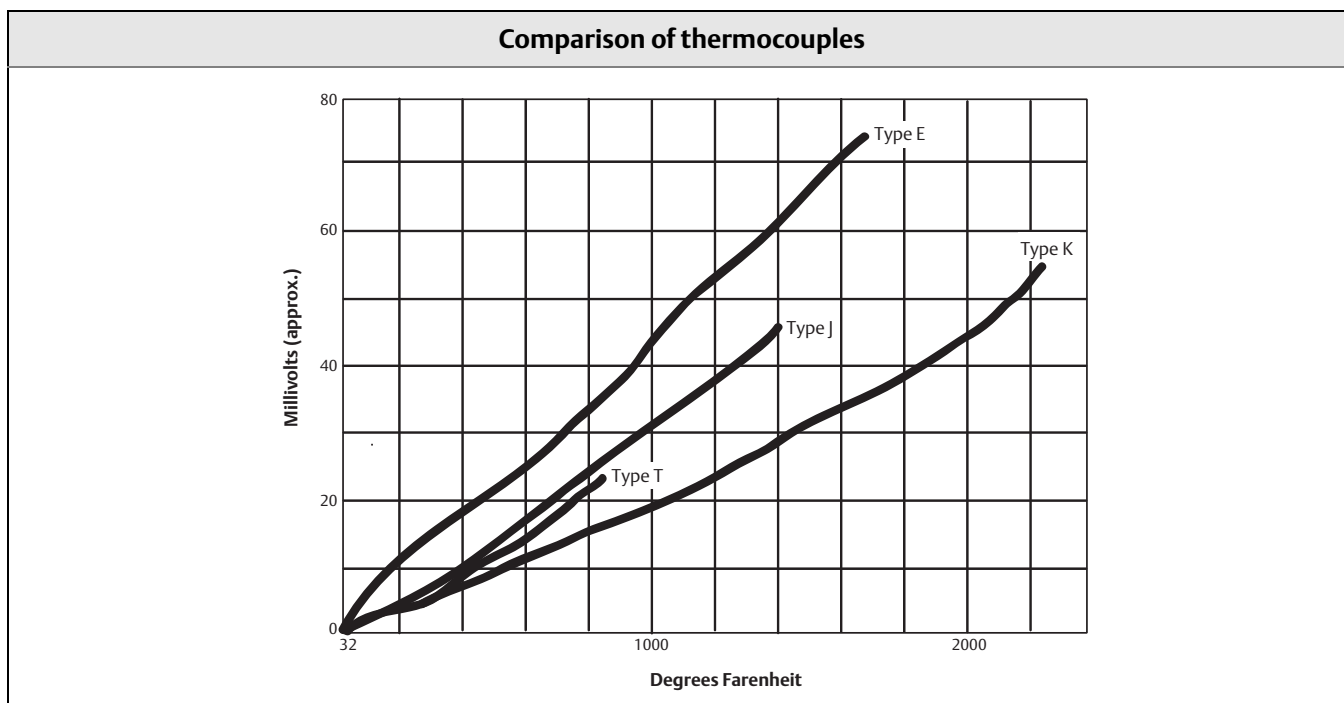
##### Insulation resistance

$100 \times 10^6$  ohms minimum insulation resistance when measured at 100 Vdc at room temperature.

##### Enclosure ratings

When installed properly, Rosemount Series 183 Sensors are suitable for indoor and outdoor NEMA 4X and installations. See [Hazardous area approvals](#) for complete installation information.





Thermocouple	Conditions for use
Type J Iron/Constantan	Maximum operating temperature of 760 °C (1400 °F). Used with or without protective tubing where deficiency of free oxygen exists. Protective tube not essential, but desirable for cleanliness and longer service.
Type K Chromel/Alumel	Suitable for extended use in temperatures reaching 1150 °C (2102 °F). Use of metal or ceramic protective tube desirable, especially in reducing atmospheres. In oxidizing atmospheres, protective tubing necessary only to promote cleanliness and longer service.
Type E Chromel/Constantan	Suitable for use at temperature up to 871 °C (1600 °F) in vacuum or inert, mildly oxidizing, or reducing atmosphere. Not subject to corrosion at cryogenic temperatures. Has highest EMF output per degree of all commonly used thermocouples.
Type T Copper/Constantan	Operating temperature range of -180 to 371 °C (-292 to 700 °F). Use in either oxidizing or reducing atmospheres. Protective tubing necessary only to promote cleanliness and longer service. Stable at lower temperature. Superior for a wide variety of uses in cryogenic temperatures.

**Table 23. Characteristics of Series 183 Thermocouple Types**

ISA thermocouple types	Thermocouple wire alloys	Temperature range		Limits of error (interchangeability)
		°C	°F	
J	Iron/Constantan	0 to 760	32 to 1400	±1.1 °C (2.0 °F) or ±0.4% of measured temperature, whichever is greater
K	Chromel/Alumel	0 to 1150	32 to 2102	±1.1 °C (2.0 °F) or ±0.4% of measured temperature, whichever is greater
E	Chromel/Constantan	0 to 871	32 to 1600	±1.0 °C (1.8 °F) or ±0.4% of measured temperature, whichever is greater
T	Copper/Constantan	-180 to 0	-292 to 32	±1.0 °C (1.8 °F) or ±1.5% of measured temperature, whichever is greater
		0 to 371	32 to 700	±0.5 °C (1.0 °F) or ±0.4% of measured temperature, whichever is greater

## Series 68Q Sanitary Platinum RTD

Rosemount Series 68Q Sanitary RTD Temperature Sensors measure from  $-50$  to  $200$  °C ( $-58$  to  $392$  °F). Series 68Q Sensors are available in Tri-Clamp endcap designs in immersion lengths from 1.0 to 9.5 inches. Table 24 shows the interchangeability of the Series 68Q Sensor.

### Accuracy

**Table 24. Series 68Q interchangeability (IEC 751 Class B)**

$\pm 0.55$ °C ( $\pm 0.99$ °F) at $-50$ °C ( $-58$ °F)
$\pm 0.30$ °C ( $\pm 0.54$ °F) at $0$ °C ( $32$ °F)
$\pm 0.80$ °C ( $\pm 1.44$ °F) at $100$ °C ( $212$ °F)
$\pm 1.30$ °C ( $\pm 2.34$ °F) at $200$ °C ( $392$ °F)

### Construction

Series 68Q Sensors conform to 3A Sanitary Standards and feature product contact surfaces designed for CIP cleaning. The response times of Series 68Q Sensors meet the Grade A Pasteurized Milk Ordinance (PMO) specification for thermometric response of an indicating thermometer on a pipeline.

Series 68Q Sensors are offered in a Tri-Clamp sanitary endcap configuration. The sensor capsule is welded into the 316 SST sanitary endcap/stem assembly. The product contact of this assembly is polished to a finish that exceeds No. 4 minimum finish as required by the 3A Sanitary Council Standard #74-02.

### Platinum element and lead wire configurations

Single-element temperature sensors have four lead wires and may be used in 2-, 3-, and 4-wire signal conditioning systems. Dual-element sensors have six lead wires and may be used in 2- and 3-wire signal conditioning systems.

### Specifications

#### Performance specifications

##### Temperature range

$-50$  to  $200$  °C ( $-58$  to  $392$  °F)

##### Maximum hysteresis

$\pm 0.09\%$  of operating temperature range

#### Stability

##### Tri-Clamp O.D. tube size 1-in. and greater

$\pm 0.04\%$  maximum ice-point resistance shift following 1,000 hours at maximum specified temperature  $392$  °F ( $200$  °C)

##### Tri-Clamp O.D. tube size $1/2$ - $3/4$ -in.

$\pm 0.08\%$  maximum ice-point resistance shift following 1,000 hours at maximum specified temperature  $392$  °F ( $200$  °C)

#### Response time

##### Tri-Clamp O.D. tube size 1-in. and greater

Less than 3.5 seconds required to reach 63.2% sensor response in water flowing at 3 ft/s (0.91 m/s). Meets PMO specification

##### Tri-Clamp O.D. tube size $1/2$ - $3/4$ -in.

Less than 1.5 seconds required to reach 63.2% sensor response in water flowing at 3 ft/s (0.91 m/s)

#### Insulation resistance

$500 \times 10^6$  ohms minimum insulation resistance when measured at 100 Vdc at room temperature

#### Surface finish

32R<sub>A</sub> standard finish on product contact surfaces. Meets 3A requirements

15R<sub>A</sub> high mechanical polish available with option code HP.

#### Environmental specifications

##### Humidity limits

Lead seal is capable of withstanding 100% relative humidity

##### Quality assurance

Each sensor is subjected to a resistance accuracy test at  $0$  °C

#### Physical specifications

##### Sheath material

316L SST

##### Lead wire

PTFE-insulated, nickel-coated, 24-gauge stranded copper wire

##### Identification data

The model and serial numbers and up to six lines of permanent tagging information are etched on each sensor adapter. Stainless steel tags are available upon request.

### Dimensional drawings

<b>68Q Sanitary Sensor with Tri-Clamp endcap</b>	
<p><b>Stepped stem</b></p> <p>A. Tri-Clamp Endcap B. Stem</p>	<p><b>Straight stem</b></p> <p>A. Tri-Clamp Process Connection 1-in. to 3-in. O.D. tube size</p>
<b>68Q Mini General Purpose Sensor with cable and strain relief</b>	
<p>A. Vinyl Strain Relief B. Lead Wire Length C. Tri-Clamp Process Connection 1/2-in. to 3/4-in. O.D. tube size</p>	
<b>68Q Mini General Purpose Sensor with 1/2-in. NPT threaded adapter</b>	
<p>A. Tri-Clamp Process Connection 1/2-in. to 3/4-in. O.D. tube size</p>	
<b>68Q Mini Spring Loaded Sensor with thermowell and replaceable sensor</b>	
<p>Dimensions are in inches (millimeters).</p>	

Table 25. Series 68Q Spare Parts List

Mini spring-loaded sanitary replacement sensors and thermowells		
Immersion length (U)	Replacement sensor part number	Replacement thermowell part number
2.0	00068-4035-0020	00068-4035-1020
2.5	00068-4035-0025	00068-4035-1025
3.0	00068-4035-0030	00068-4035-1030

## Series 58C Platinum RTD

Rosemount Series 58C Sensors are available in 12-, 24-, 36-, and 48-inch (X) lengths and may be shortened to any desired length with an ordinary tube cutter. This cut-to-fit feature eliminates the need to stock a large selection of sensors in many specific lengths. Table 26 shows the interchangeability of the Series 58C Sensor.

**Table 26. Series 58C Interchangeability (IEC 751 Class B)**

±0.55 °C (±0.99 °F) at -50 °C (-58 °F)
±0.30 °C (±0.54 °F) at 0 °C (32 °F)
±0.80 °C (±1.44 °F) at 100 °C (212 °F)
±1.30 °C (±2.34 °F) at 200 °C (392 °F)

### Specifications

#### Performance specifications

##### Temperature range

-50 to 200 °C (-58 to 392 °F)

##### Maximum hysteresis

±0.09% of operating temperature range

#### Stability

±0.035% maximum ice-point resistance shift following 1,000 hours at maximum specified temperature (200 °C)

#### Insulation resistance

500 x 10<sup>6</sup> ohms minimum insulation resistance when measured at 50 Vdc at room temperature

#### Environmental specifications

##### Humidity limits

No permanent rear seal is installed

##### Quality assurance

Each sensor is subjected to a resistance accuracy test at 0 °C and an insulation resistance test

#### Physical specifications

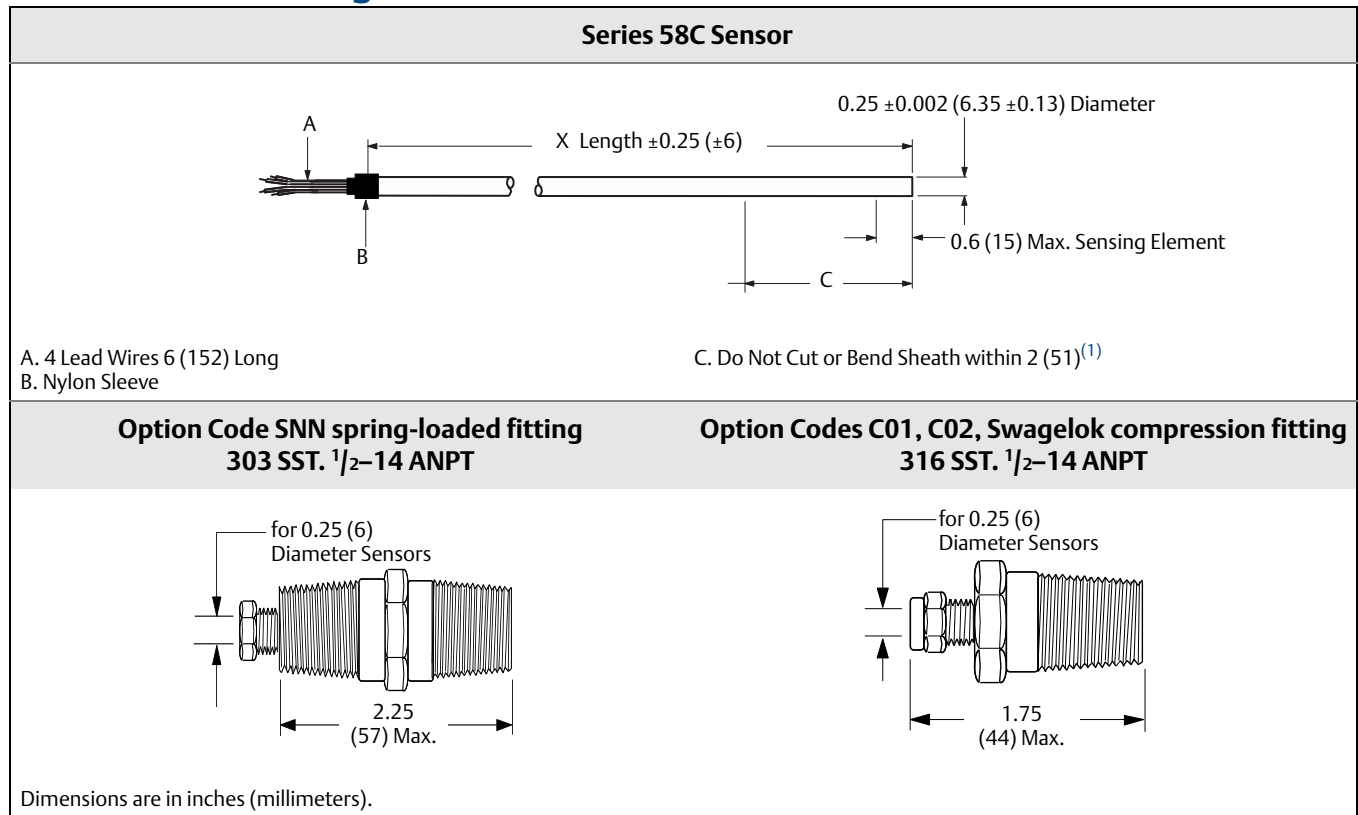
##### Sheath material

316 SST

##### Lead wires

PTFE-insulated, nickel-coated, 24-gauge stranded copper wire

## Dimensional drawings



(1) Do not cut all the way through the sensor sheath when cutting the sensor to length. Damage to the sensor wires could result. To prevent damage to the sensor wires, score the sheath considerably with a tube cutter and gently break off the excess.

# Calibration

## Calibration options

Sensor calibration may be required for input to quality systems, or for control system enhancement. More frequently, it is used to improve the overall temperature measurement performance by matching the sensor to a temperature transmitter.

Transmitter-Sensor matching is available for RTD sensors used with Rosemount temperature transmitters where the inherent stability and repeatability of the RTD technology is well established.

### Transmitter-sensor matching using Callendar-Van Dusen constants

Significant temperature measurement accuracy improvement can be attained using a temperature sensor that is matched to a temperature transmitter. This matching process entails *teaching* the temperature transmitter the relationship between resistance and temperature for a specific RTD sensor. This relationship, approximated by the Callendar-Van Dusen equation, is described as:

$$R_t = R_0 + R_0 \alpha [t - \delta(0.01t - 1)(0.01t) - \beta(0.01t - 1)(0.01t)^3],$$

where:

- $R_t$  = Resistance (ohms) at Temperature  $t$  (°C)
- $R_0$  = Sensor-Specific Constant (Resistance at  $t = 0$  °C)
- $\alpha$  = Sensor-Specific Constant
- $\delta$  = Sensor-Specific Constant
- $\beta$  = Sensor-Specific Constant (0 at  $t > 0$  °C, 0.11 at  $t < 0$  °C)

The exact values for  $R_0$ ,  $\alpha$ ,  $\delta$ ,  $\beta$ , – known as Callendar-Van Dusen (CVD) constants – are specific to each RTD sensor, and are established by testing each individual sensor at various temperatures.

The calibration temperature values using the CVD equation are divided into two major temperature areas: above 0 °C and below 0 °C. The calibration for the temperature range between 0 and 660 °C is obtained from the following formula:

$$R_t = R_0 \left\{ 1 + a \left[ t - d \left( \frac{t}{100} \right) \left( \frac{t}{100} - 1 \right) \right] \right\}$$

Note that this is a modification of the fourth-order CVD equation where  $\beta = 0$  for temperatures greater than 0 °C. Since this modified equation is a second-order degree equation, at least three distinct temperature values are needed in order to curve fit the behavior of the RTD. For the temperature range from 0 to 100 °C, only these two end points are used, and an approximation is made to render the constants.

Once the sensor-specific constants are entered, the transmitter uses them to generate a custom curve to best describe the relationship between resistance and temperature for the particular sensor and transmitter system. Matching a Series 68 or 78 RTD Sensor to a Rosemount transmitter typically results in a 3- or 4-fold improvement in temperature measurement accuracy for the total system. This substantial system accuracy improvement is realized as a result of the transmitter's ability to use the sensor's *actual* resistance-vs.-temperature curve instead of an *ideal* curve.

An example of the benefits of using the sensor matching capability of a Rosemount 3144P Temperature Transmitter along with a matched Series 68 RTD Sensor are shown in [Typical transmitter-sensor matching uncertainty improvements](#).

### Calibration uncertainty

Calibration uncertainties of the lab are equal to or better than  $1/10$  IEC 751 Class B interchangeability:

$$\text{Uncertainty} = 0.03 + 0.0005x|t|$$

$$|t| = \text{absolute value of temperature in } ^\circ\text{C}$$

## Typical transmitter-sensor matching uncertainty improvements

Transmitter: 3144 (has built-in sensor matching capabilities), span of 1 to 200 °C, accuracy = 0.1 °C)

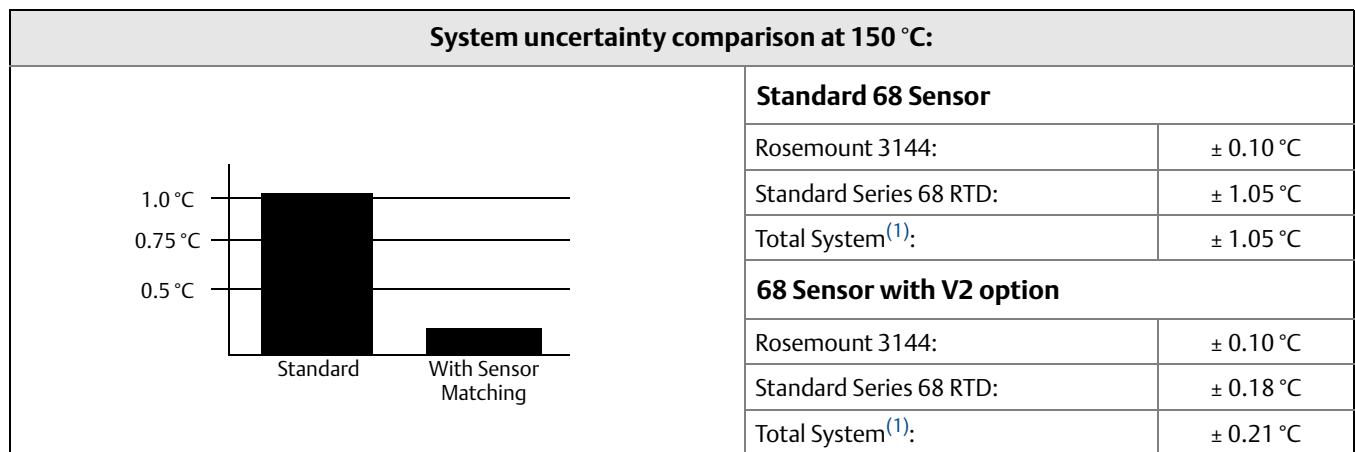
Sensor: Series 68 RTD

Callendar van Dusen Option: V2

Process Temperature: 150 °C

Temperature		Sensor interchangeability error		Total calibrated sensor uncertainty <sup>(1)</sup>	
°C	°F	°C	°F	°C	°F
0	32	±0.30	±0.54	±0.10	±0.18
50	122	±0.55	±0.99	±0.17	±0.31
100	212	±0.80	±1.44	±0.22	±0.40
150	302	±1.05	±1.89	±0.18	±0.32
200	392	±1.30	±2.34	±0.16	±0.29

(1) Includes calibration uncertainties of the lab, hysteresis, and repeatability.



(1) Calculated using RSS statistical method:

$$\text{SystemAccuracy} = \sqrt{(\text{TransmitterAccuracy})^2 + (\text{SensorAccuracy})^2}$$

## Ordering information

### Sensor characterization (calibration) schedules– Option Code V

Series 68, 68Q, and 78 RTD sensors can be ordered with an option (V1, V2,...V7, see [Option Code “V” Callendar-van Dusen Constants](#)), that provides Callendar-Van Dusen constants that are shipped with the sensor. When you order this option, the values of all four sensor-specific constants are physically attached to each sensor with a wire-on tag. Rosemount transmitters have a unique, built-in sensor matching capability. To use this capability, the four sensor-specific constants are programmed into the transmitter at the factory by ordering a C2 option on the transmitter, or easily entered and changed in the field using a Field Communicator or AMS. When these values are entered into a Rosemount transmitter, the sensor and transmitter become *matched*.

Each “V” option is specific to a particular temperature range for a given sensor type (see [Option Code “V” Callendar-van Dusen Constants](#)).

For applications requiring the increased accuracy obtainable through a matched sensor and transmitter, order the appropriate “V” option (see [Option Code “V” Callendar-van Dusen Constants](#)). To ensure optimal performance, select a “V” option such that the sensor’s range of actual operation is between the minimum and maximum calibration points.

#### Note

An RTD ordered with the V option is shipped with CVD constants only; it does not include calibration tables.



**Option Code “V” Callendar-van Dusen Constants**

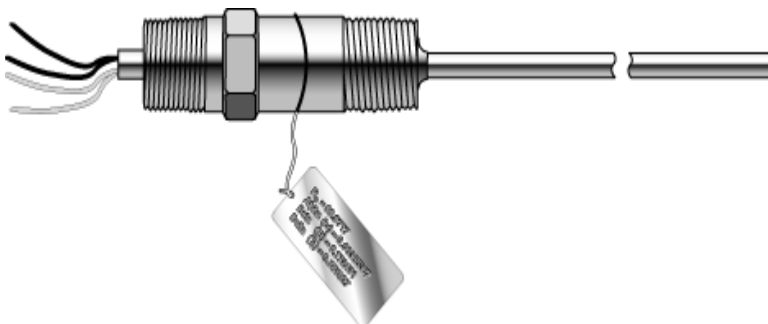
Option code	Temperature range		Calibration points	
V1	0 to 100	32 to 212	0	32
			100	212
V2	0 to 200	32 to 392	0	32
			100	212
V3	0 to 400	32 to 752	200	392
			0	32
			200	392
			400	752
V4 <sup>(1)</sup>	0 to 600	32 to 1112	0	32
			200	392
			400	752
V5	-50 to 100	-58 to 212	0	32
			100	212
V6	-50 to 200	-58 to 392	-50	-58
			0	32
			100	212
			200	392
V7	-50 to 400	-58 to 752	-50	-58
			0	32
			200	392
			400	752

(1) Only available with Series 78 High Temperature Sensors 10-in. or longer.

**Table 27. Ordering Information**

Specify sensor model number with “V” Option example								
Sensor Model	0068	N	11	N	00	N	120	V2

**Figure 12. Typical Sensor Ordered with Option Code V**

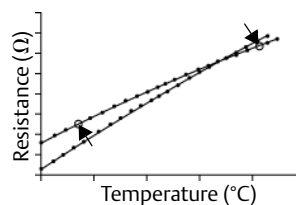


## Option Code X8Q4

The X8Q4 option calibrates the sensor to a customer-specified temperature range. The exact range that the sensor is calibrated to is based on the calibration schedules available. At a minimum, the sensor calibration will encompass the requested calibration range. The X8Q4 report includes the Callendar-Van Dusen (CVD) constants ( $R_0$ ,  $\alpha$ ,  $\delta$ ,  $\beta$ ), a resistance-versus-temperature table in one-degree increments, and a graph which includes the maximum errors due to the uncertainty of the calibration equipment, hysteresis, and repeatability. The values in the tables are calculated using Callendar-Van Dusen methodology. Two of the values on this table could be used to perform a two-point trim. The X8Q4 option also provides the CVD constants on a stainless steel tag attached to the sensor.

See [Figure 13](#).

**Figure 13. Graph of a Typical Two-Point Trim**



A two-point trim shifts the ideal curve up or down, and changes the slope based on the two characterized points.

### Option X8Q4: sensor calibrated to a customer-specified temperature range

When you order an RTD with the X8Q4 option, you must specify a temperature range over which the sensor is to be calibrated. Before specifying the range, take careful note of the sensor temperature limits.

**Table 28. Ordering Example**

Typical Model Number	Model	Lead wire termination	Sensor type	Extension type	Extension length	Thermowell material	Immersion length	Additional options
	0068	N	11	N	00	N	045	X8Q4 X8X9Q4

If X8Q4 and X9Q4 are both required, do not repeat the “Q4” code in the model string. Include the following instead:

Calibrate from –10 to 120 °C

**Option Code X9Q4**

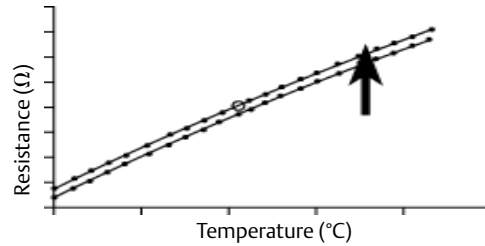
The X9Q4 option calibrates the sensor at a single customer-specified point. A calibration certificate with the resistance value at this point is supplied. This value could be used to perform a one-point trim on the transmitter. All characterizations are traceable to the National Institute of Standards and Technology (NIST). The calibration table is dated and marked with the sensor series and serial number.

See [Figure 14](#).

**Note**

The X9Q4 option can be ordered and used in conjunction with the X8Q4 option.

**Figure 14. Graph of a Typical One-Point Trim**



A one-point trim shifts the ideal curve up or down based on the single characterized point.

**Option X9Q4: sensor calibrated to a customer-specified single point**

When you order an RTD with the X9Q4 option, you must specify a single temperature point at which the sensor is to be calibrated. Before specifying the point, take careful note of the sensor temperature limits.

**Table 29. Ordering Example**

Typical Model Number	Model	Lead wire termination	Sensor type	Extension type	Extension length	Thermowell material	Immersion length	Additional options
	0068	N	11	N	00	N	045	X9Q4

If X8Q4 and X9Q4 are both required, do not repeat the “Q4” code in the model string. Include the following instead:

X8X9Q4 Calibrate at 50 °C

Table 30. Resistance vs. Temperature

IEC 751 Platinum 100, $\alpha = 0.00385$ RTD											
°F	Ohms	°F	Ohms	°F	Ohms	°C	Ohms	°C	Ohms	°C	Ohms
-330	18.04	210	138.08	690	235.15	-200	18.52	90	134.71	380	240.18
-320	20.44	220	140.19	700	237.09	-190	22.83	100	138.51	390	243.64
-310	22.83	230	142.29	710	239.02	-180	27.10	110	142.29	400	247.09
-300	25.20	240	144.39	720	240.95	-170	31.34	120	146.07	410	250.53
-290	27.57	250	146.49	730	242.87	-160	35.54	130	149.83	420	253.96
-280	29.93	260	148.58	740	244.79	-150	39.72	140	153.58	430	257.38
-270	32.27	270	150.67	750	246.71	-140	43.88	150	157.33	440	260.78
-260	34.61	280	152.75	760	248.62	-130	48.00	160	161.05	450	264.18
-250	36.94	290	154.83	770	250.53	-120	52.11	170	164.77	460	267.56
-240	39.26	300	156.91	780	252.44	-110	56.19	180	168.48	470	270.93
-230	41.57	310	158.98	790	254.34	-100	60.26	190	172.17	480	274.29
-220	43.88	320	161.05	800	256.24	-90	64.30	200	175.86	490	277.64
-210	46.17	330	163.12	810	258.14	-80	68.33	210	179.53	500	280.98
-200	48.46	340	165.18	820	260.03	-70	72.33	220	183.17	510	284.30
-190	50.74	350	167.24	840	263.80	-60	76.33	230	186.84	520	287.62
-180	53.02	360	169.30	850	265.68	-50	80.31	240	190.47	530	290.92
-170	55.29	370	171.35	860	267.56	-40	84.27	250	194.10	540	294.21
-160	57.55	380	173.40	870	269.44	-30	88.22	260	197.71	550	297.49
-150	59.81	390	175.45	880	271.31	-20	92.16	270	201.31	560	300.74
-140	62.06	400	177.49	890	273.17	-10	96.09	280	204.90	570	304.01
-130	64.30	410	179.53	900	275.04	0	100.00	290	208.48	580	307.25
-120	66.54	420	181.56	910	276.90	10	103.90	300	212.05	590	310.49
-110	68.77	430	183.59	920	278.75	20	107.79	310	215.61	600	313.71
-100	71.00	380	173.40	930	280.61	30	111.67	320	219.15	N/A	N/A
-90	73.22	390	175.45	940	282.46	40	115.54	330	222.68	N/A	N/A
-80	75.44	400	177.49	950	284.30	50	119.40	340	226.21	N/A	N/A
-70	77.66	410	179.53	960	286.14	60	123.24	350	229.72	N/A	N/A
-60	79.86	420	181.56	970	287.98	70	127.08	360	233.21	N/A	N/A
-50	82.07	430	183.59	980	289.82	80	130.90	370	236.70	N/A	N/A

IEC 751 Platinum 100, $\alpha = 0.00385$ RTD											
°F	Ohms	°F	Ohms	°F	Ohms	°C	Ohms	°C	Ohms	°C	Ohms
-40	84.27	450	187.65	990	291.65	<i>Note</i> To convert from °C to °F: $\{1.8 \times (°C)\} + 32 = °F$ Example: $(1.8 \times 100) + 32 = 212 °F$  To convert from °F to °C: $0.556 [(°F) - 32] = 100 °F$ Example: $0.556 (212 - 32) = 100 °C$					
-30	86.47	460	189.67	1000	293.48						
-20	88.66	470	191.68	1010	295.30						
-10	90.85	480	193.70	1020	297.12						
0	93.03	490	195.71	1030	298.94						
10	95.21	500	197.71	1040	300.75						
20	97.39	510	199.71	1050	302.56						
30	99.57	520	201.71	1060	304.37						
40	101.74	530	203.71	1070	306.17						
50	103.90	540	205.70	1080	307.97						
60	106.07	550	207.69	1090	309.77						
70	108.23	560	209.67	1100	311.56						
80	110.38	570	211.66	1110	313.35						
90	112.53	580	213.63	1120	315.14						
100	114.68	590	215.61	N/A	N/A						
110	116.83	600	217.58	N/A	N/A						
120	118.97	610	219.55	N/A	N/A						
130	121.11	620	221.51	N/A	N/A						
140	123.24	630	223.47	N/A	N/A						
150	125.37	640	225.42	N/A	N/A						
160	127.50	650	227.38	N/A	N/A						
170	129.62	660	229.33	N/A	N/A	N/A	N/A	N/A	N/A	N/A	N/A
180	131.74	670	231.27	N/A	N/A	N/A	N/A	N/A	N/A	N/A	N/A
190	133.86	680	233.21	N/A	N/A	N/A	N/A	N/A	N/A	N/A	N/A
200	135.97	N/A	N/A	N/A	N/A	N/A	N/A	N/A	N/A	N/A	N/A

## Mounting accessories

### Rosemount connection head

The Rosemount Connection Head is for general-purpose and spring-loaded sensors. The terminal block has six terminals for either single or dual element sensors. If the sensor assembly is ordered assembled to a Rosemount 248 or 644H Head Mount Transmitter, then the terminal block is replaced by the transmitters.

### Specifications

#### Sensor connection

- 1/2–14 ANPT mounting thread. Screw terminals for lead wire connections.

#### Electrical connection

- 1/2–14 ANPT conduit

#### Materials of construction

- Housing: Low copper aluminum or stainless steel
- Paint: Polyurethane (stainless steel not painted)
- Cover O-ring: Buna-N

#### Enclosure rating

- NEMA 4X, IP66, and IP68

### Polypropylene connection head

The polypropylene connection head is designed for use with sanitary sensors. It is FDA-compliant, and is resistant to attack by acids, alkalis, and organic solvents.

### Specifications

#### Sensor connection

- 1/2–14 NPT mounting thread. Screw terminals for lead wire connections

#### Electrical connection

- 1/2–14 NPT conduit

#### Materials of construction

- Housing: White polypropylene polymer
- O-Ring Seal: Silicone rubber
- Terminals: Nickel-plated brass

#### Temperature limits

- –10 to 92 °C (14 to 198 °F)

## Connection head

The Extended Cover Connection Head provides the additional space required by sensors that have bayonet connectors. This model can also be used with general-purpose and spring-loaded sensors. The terminal block has six terminals for either single- or dual-element sensors.

The Flat Cover Connection Head is for general-purpose and spring-loaded sensors. The terminal block has six terminals for either single- or dual-element sensors.

## Specifications

### Sensor connection

- 1/2–14 ANPT mounting thread. Screw terminals for lead wire connections

### Electrical connection

- 3/4–14 ANPT conduit

### Materials of construction

- Housing: Low-copper aluminum alloy
- O-Ring Seal: Silicone rubber
- Terminals: Nickel-plated brass

## Temperature limits

Head type	Unapproved	E5 option	E6 option	E1 option
Painted	–100 to 100 °C –148 to 212 °F	–50 to 85 °C –58 to 185 °F	–50 to 85 °C –58 to 185 °F	–40 to 65 °C –40 to 149 °F
Unpainted	–100 to 200 °C –148 to 392 °F	–50 to 85 °C –58 to 185 °F	–50 to 200 °C –58 to 392 °F	–40 to 65 °C –40 to 149 °F

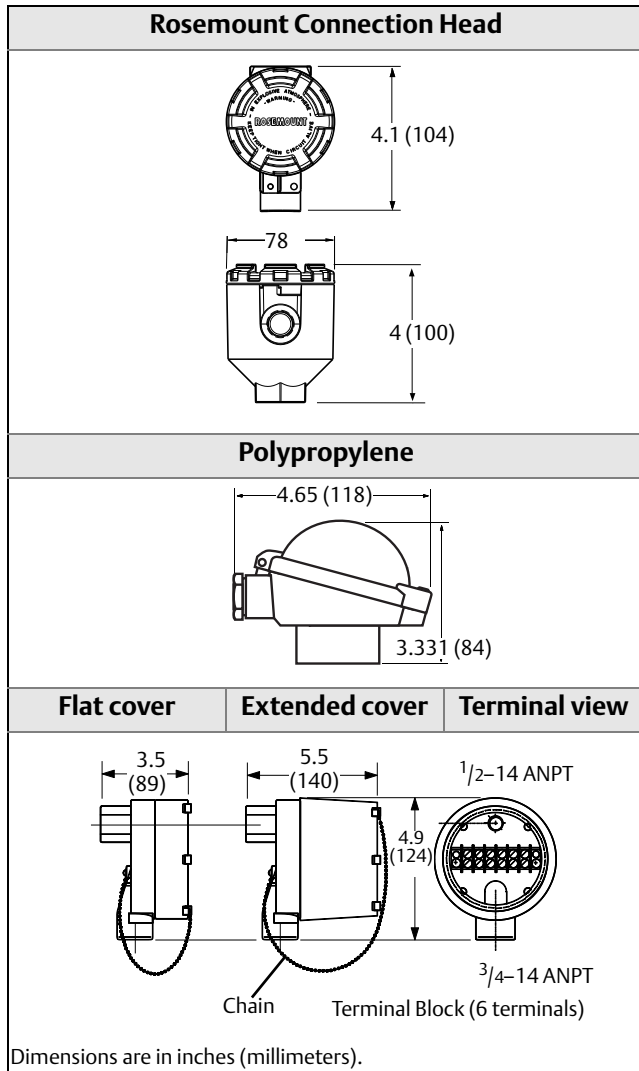
### Enclosure ratings

When installed properly, painted connection heads are suitable for indoor and outdoor NEMA 4X installations. When installed properly, unpainted connection heads are suitable for NEMA 4 installations. See [Hazardous area approvals](#) for complete installation information.

## Connection head model numbers

Part number	Description
00644-4410-0011	Rosemount Connection Head, painted aluminum
00644-4411-0011	Stainless Steel, Rosemount connection head, Standard cover, 1/2ANPTX1/2ANPT
007903252003	Six Terminals with Flat Cover, Unapproved, Unpainted
007903242003	Six Terminals with Extended Cover, Unapproved, Unpainted
007903250002	Six Terminals with Flat Cover, FM Approved, Unpainted
007903240002	Six Terminals with Extended Cover, FM Approved, Unpainted
007903250003	Six Terminals with Flat Cover, CSA Approved, Unpainted
007903240003	Six Terminals with Extended Cover, CSA Approved, Unpainted
007903252005	Six Terminals with Flat Cover, Unapproved, Painted
007903242005	Six Terminals with Extended Cover, Unapproved, Painted
007903250004	Six Terminals with Flat Cover, FM Approved, Painted
007903240004	Six Terminals with Extended Cover, FM Approved, Painted
007903250005	Six Terminals with Flat Cover, CSA Approved, Painted
007903240005	Six Terminals with Extended Cover, CSA Approved, Painted
00644-4198-0011	No Approval Options, White Polypropylene
00075-0003-3001	Round Terminal Block for Rosemount and Polypropylene heads
00644-4431-0001	External ground Screw Assembly for Rosemount Connection Head
00644-4435-0011	Polypropylene Connection Head with Terminal Block 1/2 in. NPT entries
00079-0329-0001	Kit of 12 Silicone Rubber O-rings for Flat/Extended Heads

Figure 15. Connection Head Dimensional Drawing



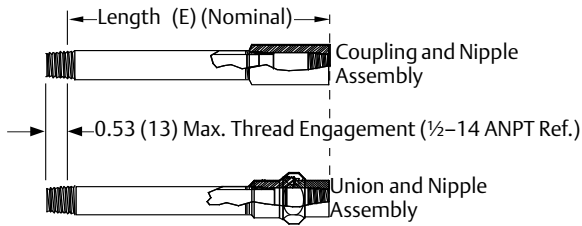


## Extension fitting assemblies

Extension fitting assemblies are available in:

- Coupling and nipple assembly
- Union and nipple assembly

**Figure 16. Extension Fitting**



Dimensions are in inches (millimeters).

**Table 31. Extension**

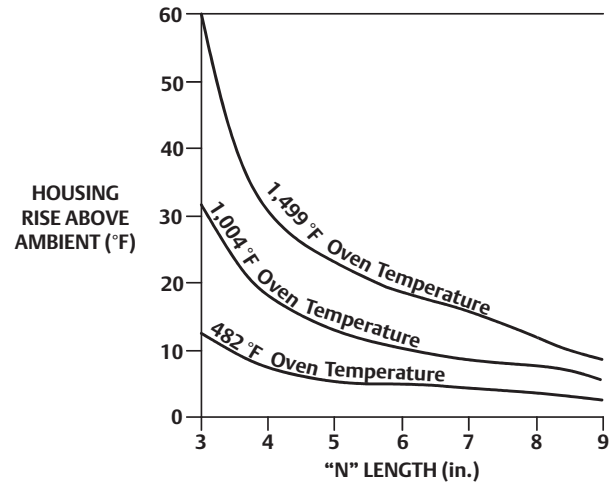
Coupling and nipple, SST		Union and nipple, SST	
Model number	Length (E)	Model number	Length (E)
007903540250	2.5-in.	007903550250	2.5-in.
007903540300	3.0-in. <sup>(1)</sup>	007903550300	3.0-in. <sup>(1)</sup>
007903540350	3.5-in.	007903550350	3.5-in.
007903540400	4.0-in.	007903550400	4.0-in.
007903540450	4.5-in.	007903550450	4.5-in.
007903540500	5.0-in.	007903550500	5.0-in.
007903540550	5.5-in.	007903550550	5.5-in.
007903540600	6.0-in. <sup>(1)</sup>	007903550600	6.0-in. <sup>(1)</sup>
007903540650	6.5-in.	007903550650	6.5-in.
007903540700	7.0-in.	007903550700	7.0-in.
007903540750	7.5-in.	007903550750	7.5-in.
007903540800	8.0-in.	007903550800	8.0-in.
007903540850	8.5-in.	007903550850	8.5-in.
007903540900	9.0-in.	007903550900	9.0-in.

(1) Standard configuration with best delivery. Also available for emergency requirements. Consult factory for information.

## Choosing an extension

Aside from ambient temperature variations, the heat from the process is transferred from the thermowell to the transmitter housing. If the process temperature is near or beyond specification limits, consider the use of additional thermowell lagging, an extension nipple, or a remote mounting configuration to isolate the transmitter from the excessive temperatures. Use [Figure 17](#) and the example below to determine an adequate extension length.

**Figure 17. 3144P Transmitter Housing Temperature Rise versus Extension Length for a Test Installation**



## Example

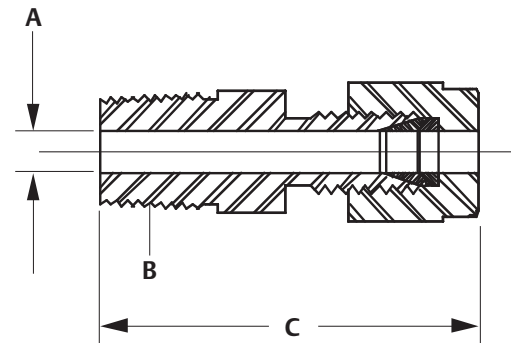
The rated ambient temperature specification is 85 °C. If the maximum ambient temperature is 40 °C and the process temperature to be measured is 540 °C, the maximum allowable housing temperature rise is the rated temperature specification limit minus the existing ambient temperature (85 – 40), or 45 °C.

As shown in [Figure 17](#), an extension (E) dimension of 3.0-in (76 mm) will result in a housing temperature rise of 30 °C. An “E” dimension of 3-in. would therefore be the minimum recommended length, and would provide a safety factor of about 15 °C. A longer “E” dimension, such as 6-in. (152 mm), would be desirable in order to reduce errors caused by transmitter temperature effect, although in that case the transmitter would probably require extra support. If a thermowell with lagging is used, the “E” dimension may be reduced by the length of the lagging.

## Mounting adapters for Series 58, 68, 78, and 183

### M5–M7, sensor compression fittings, 316 SST

- For adjustable sensor length
- For low pressure applications (100 psig maximum)
- Fits ¼-inch diameter sensors
- Available with 1/8–27 (M5), 1/4–18 (M6), and 1/2–14 (M7) ANPT process threads
- Not available on spring-loaded sensors



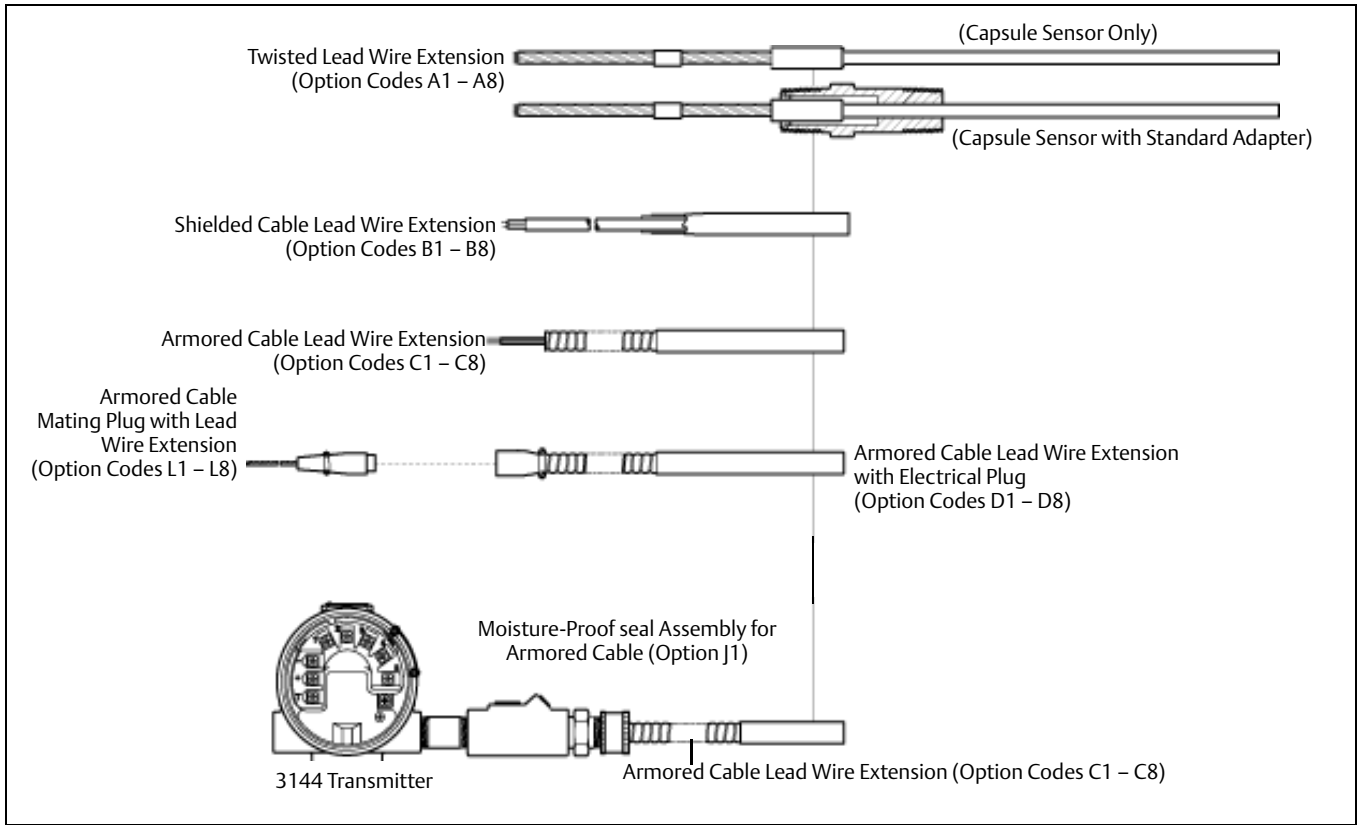
A. Fitting Diameter  
B. Sensor Process Thread  
C. Length

**Table 32. Compression Fittings, 316 SST (for Attachment to the Stem of the Capsule)**

Model number	Option code	Sensor process thread	Fitting diameter		Length	
			in.	mm	in.	mm
C07961-0005	M5	1/8–27 ANPT	0.25	6.35	1.31	33.27
C07961-0006	M6	1/4–18 ANPT	0.25	6.35	1.5	38.1
C07961-0008	M7	1/2–14 ANPT	0.25	6.35	1.75	44.45

## Lead wire extensions, connectors, and seals

The following options are available on most Series 68 and 78 sensors. They are not available for use on Series 58C, 68Q, and 183 sensors or with IECEx or ATEX Flameproof approval (Option Codes E7 or E1).



### A1–A8, twisted lead wire extension

- Lead wire connections are silver brazed and individually insulated by shrinkable PTFE tubes
- Withstands 95 percent relative humidity
- 200 °C (392 °F) maximum temperature
- Available with single or dual-element sensors

Option code	Y length (ft)	Option code	Y length (ft)
A1	1 <sup>1</sup> / <sub>2</sub>	A5	24
A2	3	A6	50
A3	6	A7	75
A4	12	A8	100



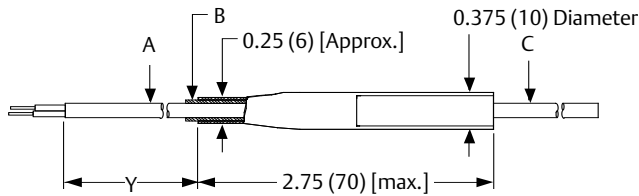
Dimensions are in inches (millimeters).

- A. 22-gauge PTFE Lead Wire
- B. PTFE
- C. Sensor

**B1–B8, shielded cable lead wire extension**

- Copper shielded cable prevents electrical noise distortions to sensor signal output
- Withstands 95 percent relative humidity
- 200 °C (392 °F) maximum temperature

Option code	Y length (ft)	Option code	Y length (ft)
B1	1 1/2	B5	24
B2	3	B6	50
B3	6	B7	75
B4	12	B8	100



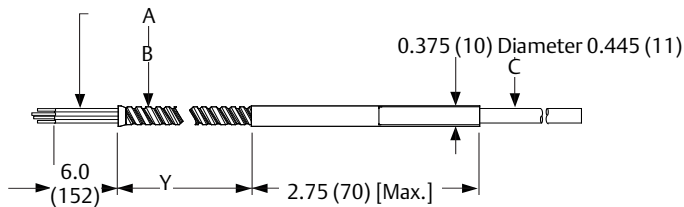
Dimensions are in inches (millimeters).

- A. Shielded Cable PTFE Jacket 22-Gauge PTFE-Insulated Wires
- B. Rubber Seal
- C. Sensor

**C1–C8, armored cable lead wire extension**

- Provides lead wire protection in heavy duty environments
- Withstands 95 percent relative humidity
- 200 °C (392 °F) maximum temperature
- Available with single or dual-element sensors

Option code	Y length (ft)	Option code	Y length (ft)
C1	1 1/2	C5	24
C2	3	C6	50
C3	6	C7	75
C4	12	C8	100



Dimensions are in inches (millimeters).

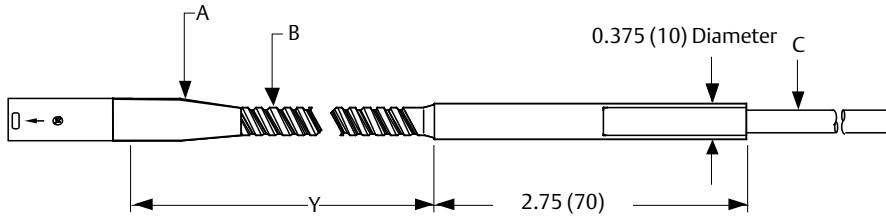
- A. 22-Gauge PTFE-Insulated Wire
- B. Armor Cable 0.34 (8.64) O.D.
- C. Sensor

**D1–D8, armored cable lead wire extension with electrical plug**

- Provides lead wire protection in heavy-duty environments
- Provides quick-disconnect capability
- Withstands 95 percent relative humidity

Option code	Y length (ft)
D1	1 1/2
D2	3
D3	6
D4	12

Option code	Y length (ft)
D5	24
D6	50
D7	75
D8	100



Dimensions are in inches (millimeters).

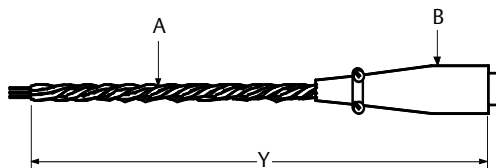
- A. Mates with Option Codes L1–L8
- B. Armor Cable 0.34 (8.64) OD
- C. Sensor

**L1–L8, armored cable mating plug with lead wire extension**

- Completes quick-disconnect capability for armored cable
- Withstands 95 percent relative humidity
- Twisted lead wire extension for lowest cost installation

Option code	Y length (ft)
L1	1 1/2
L2	3
L3	6
L4	12

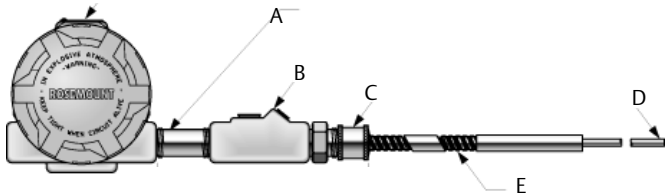
Option code	Y length (ft)
L5	24
L6	50
L7	75
L8	100



- A. 22-Gauge PTFE Lead Wire
- B. Mates with Option Codes D1–D8

### J1, moisture-proof seal assembly for armored cable

- Prevents moisture migration through armored cable
- For use in humid environments but not for direct liquid immersion
- Non-disconnectable type assembly with armored cable and sensor



- A. Nipple, 304 SST, 1/2-14 ANPT 1.12 (28.45) Long  
B. Nipple, 304 SST, 1/2-14 ANPT 1.12 (28.45) Long  
C. Compression Fitting  
D. Sensor  
E. Armored Cable Lead Wire (Specify Option Codes C1-C8)

#### Note

Not available with FM or CSA explosion proof (options E5 or E6).

Moisture-proof seal assembly must be ordered with armored cable lead wire extension (option codes C1 - C8).

# Thermowells

## Materials

Rosemount Thermowells are supplied in most materials required for industrial applications. Standard materials are 316 SST, 304 SST, and C1018 carbon steel. For corrosive environments, special materials such as alloy and Inconel 600 are available. Consult factory for other material availability.

## Strength (pressure and flow vibration)

The strength of a thermowell depends on several parameters that relate thermowell construction to the installation environment. For most industrial applications, standard Rosemount thermowells provide the necessary strength if the material, style, and length are correct for the application. The proper selection of a thermowell depends on fluid type, temperature, pressure, and fluid velocity. It is important to note that most thermowell failures are caused by vibration that is induced by fluid flow. If static pressure strength is a major consideration, refer to Table for standard material ratings for a 1/2-inch tip. Tapered thermowells are offered for additional strength.

## Strength calculation

Emerson Process Management has the ability to perform thermowell frequency calculations to verify that the thermowell dimensions you provide are appropriate for your specific application. To take advantage of this calculation, fill out and return the Thermowell Calculation Configuration Data Sheet.

## Construction

All thermowell bodies with an overall length less than 42-in. are machined from solid bar stock to ensure water-tightness. Flange mounts are welded to the thermowell body. Standard construction provides immersion lengths (U) from 2½ to 48 inches with overall lengths (L) from 4 to 59 inches respectively. Thermowells with overall lengths larger than 36-in. may be a 3-piece welded construction. Consult the factory for more information on welded 3-piece construction thermowells.

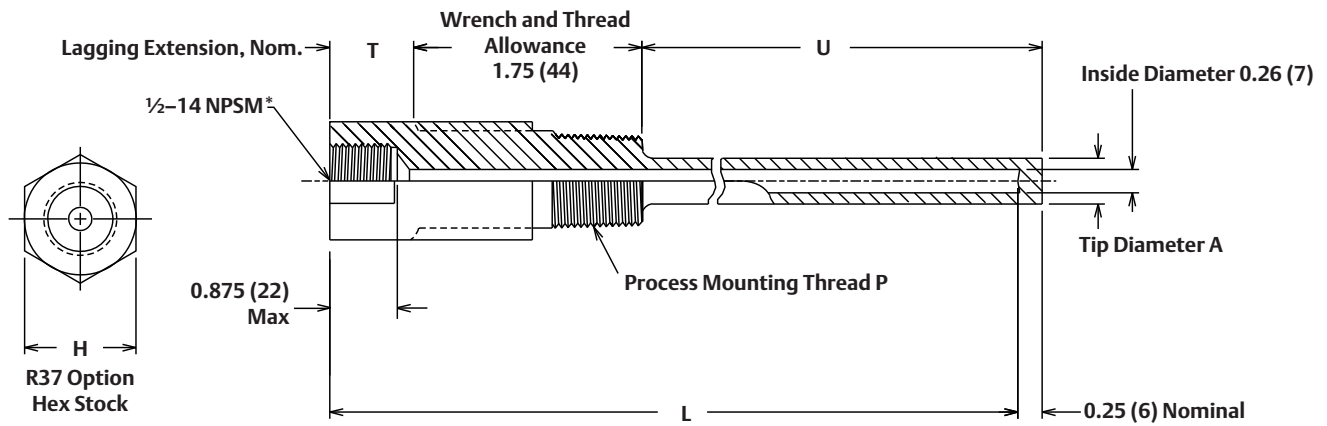
## Identification data

The part number is etched on each thermowell. Additional tagging for specific customer requirements is available.

## Installation

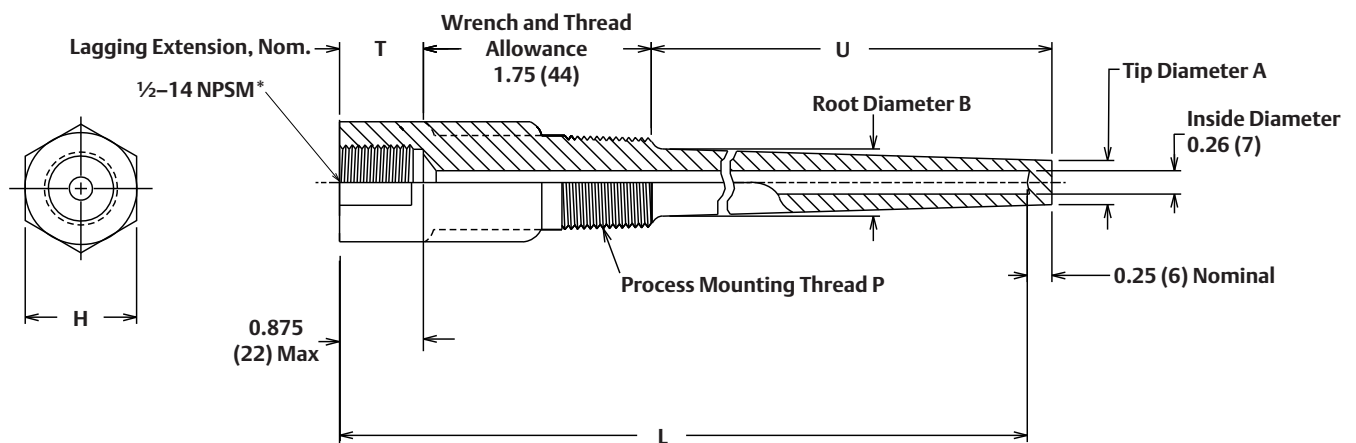
For dimensional drawings of Thread Mounted, Weld Mounted, and Flange Mounted Thermowells, refer to [Figure 19, 22, and 26](#).

**Figure 18. Thread Mounted Thermowells - Straight<sup>(1)</sup>**



Dimensions are in inches (millimeters).

**Figure 19. Thread Mounted Thermowells - Tapered<sup>(1)</sup>**



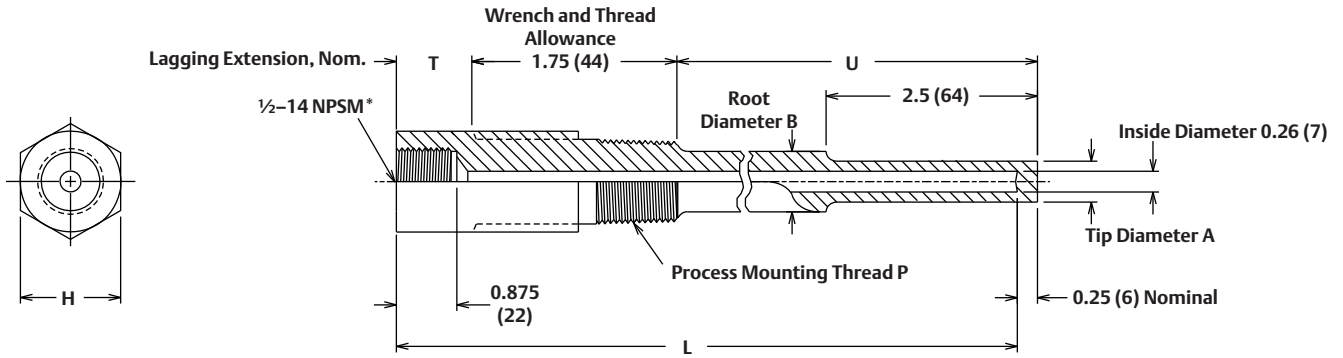
Dimensions are in inches (millimeters).

Thread (P)	Hex size inches (H)
0.5 – 0.75 ANPT	1.125
1–11.5 ANPT	1.375

(1) 1/2-14 ANPT threads are available.

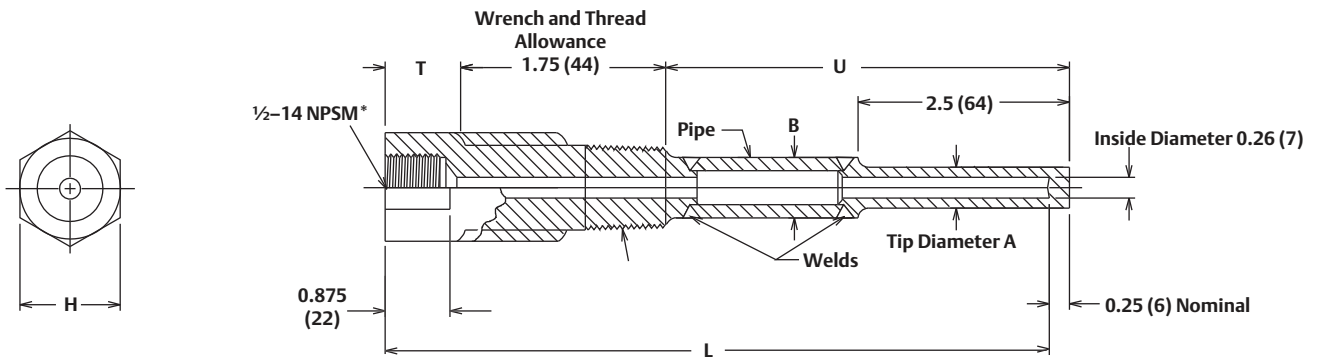


**Figure 20. Thread Mounted Thermowells - Stepped<sup>(1)</sup>**



Dimensions are in inches (millimeters).

**Figure 21. Thread Mounted Thermowells - Stepped, For Thermowells with Overall Length greater than 42-in. (3-Piece Construction)<sup>(1)</sup>**

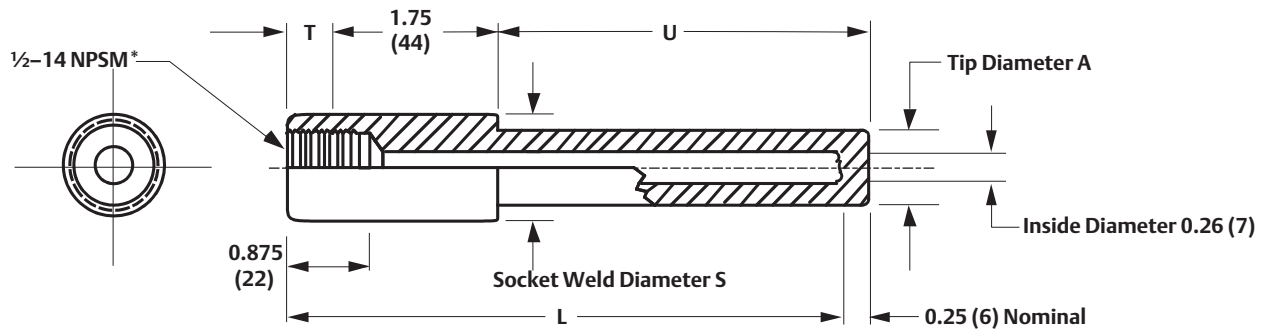


Dimensions are in inches (millimeters).

Thread (P)	Hex size inches (H)
0.5 – 0.75 ANPT	1.125
1–11.5 ANPT	1.375

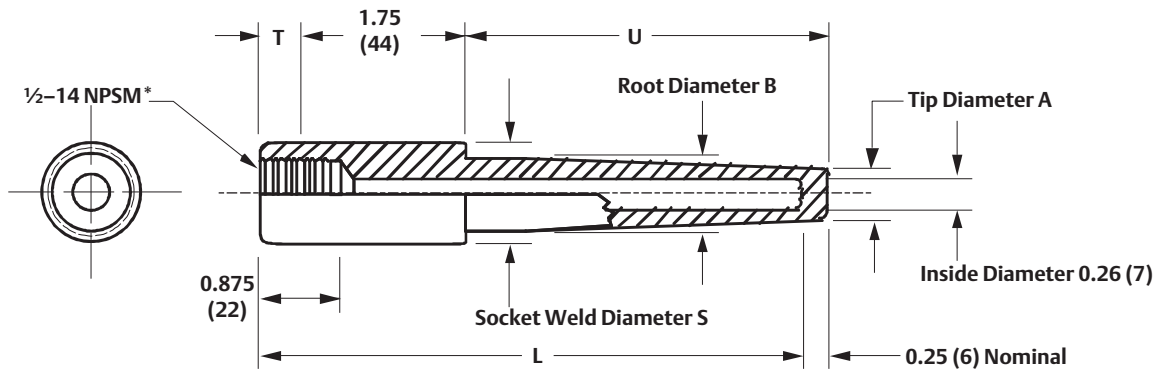
(1) <sup>1</sup>/<sub>2</sub>-14 ANPT threads are available.

Figure 22. Weld Mounted Thermowells - Straight<sup>(1)</sup>



Dimensions are in inches (millimeters).

Figure 23. Weld Mounted Thermowells - Tapered<sup>(1)</sup>

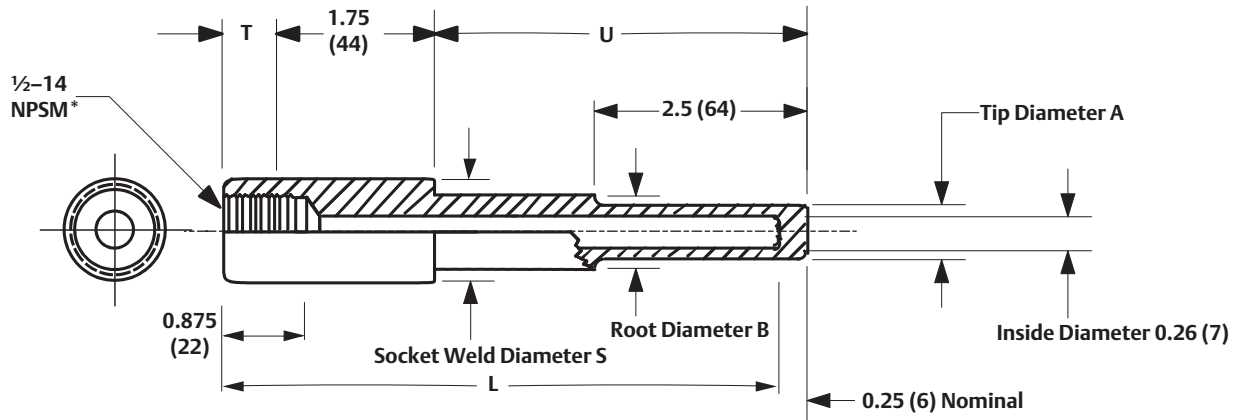


Dimensions are in inches (millimeters).

Pipe size	Socket size (S) diameter
0.75-in.	1.050 ±0.010
1-in.	1.315 ±0.010

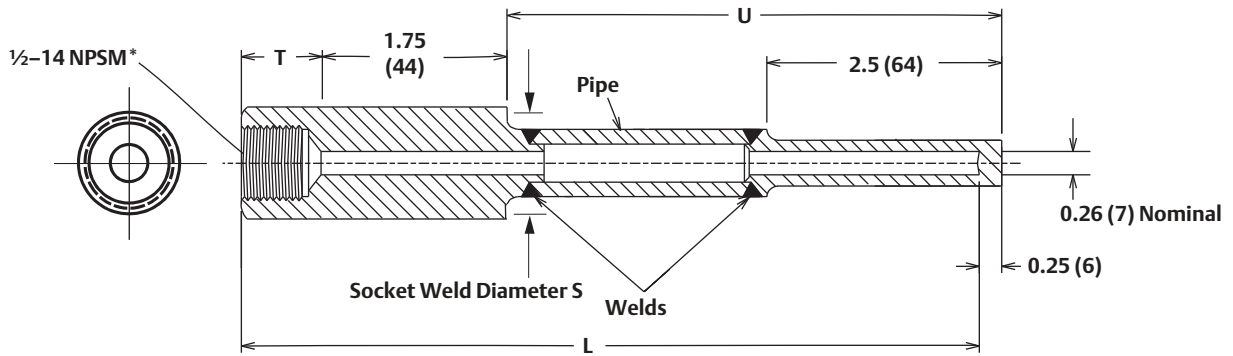
(1) 1/2-14 ANPT threads are available.

Figure 24. Weld Mounted Thermowells-Stepped<sup>(1)</sup>



Dimensions are in inches (millimeters).

Figure 25. Weld Mounted Thermowells-Stepped, For Thermowells with Overall Length greater than 42-in. (3-Piece Construction)<sup>(1)</sup>

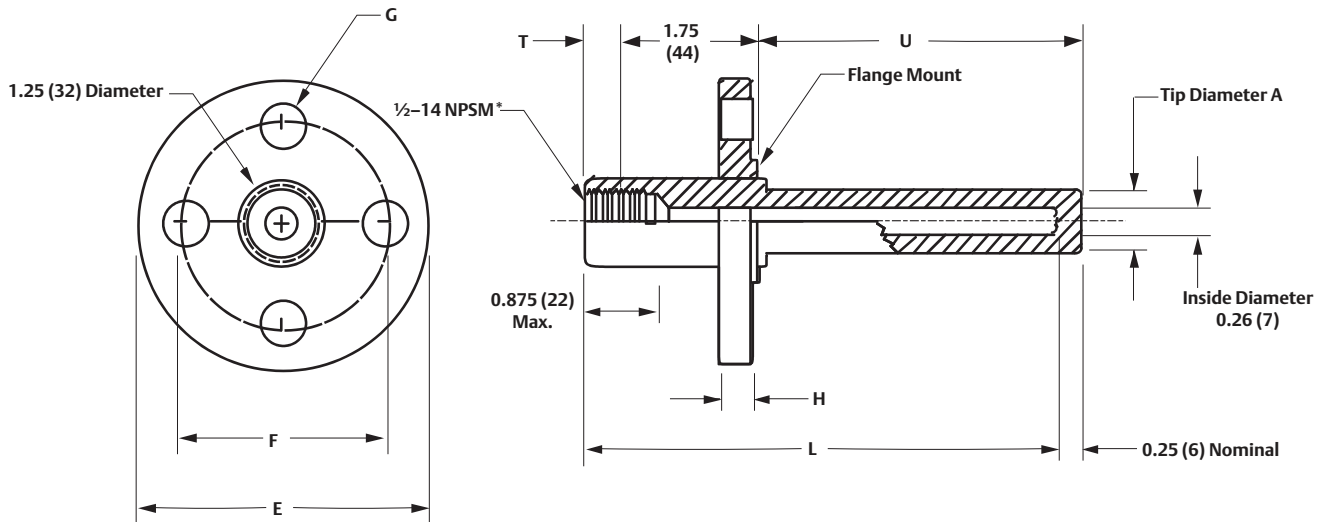


Dimensions are in inches (millimeters).

Pipe size	Socket size (S) diameter
0.75-in.	1.050 ±0.010
1-in.	1.315 ±0.010

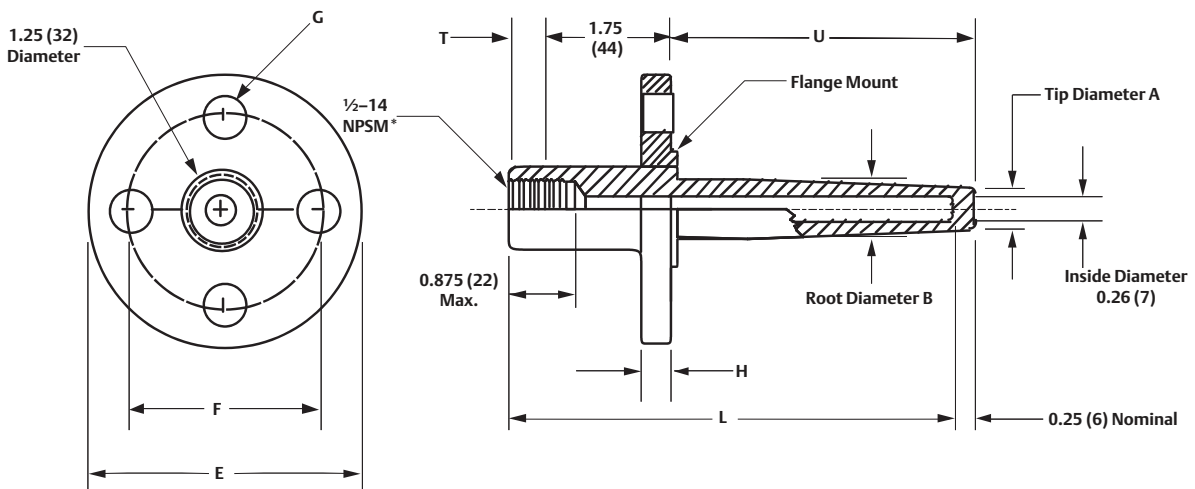
(1) 1/2-14 ANPT threads are available.

Figure 26. Flange Mounted Thermowells - Straight<sup>(1)</sup>



Dimensions are in inches (millimeters).

Figure 27. Flange Mounted Thermowells - Tapered<sup>(1)</sup>



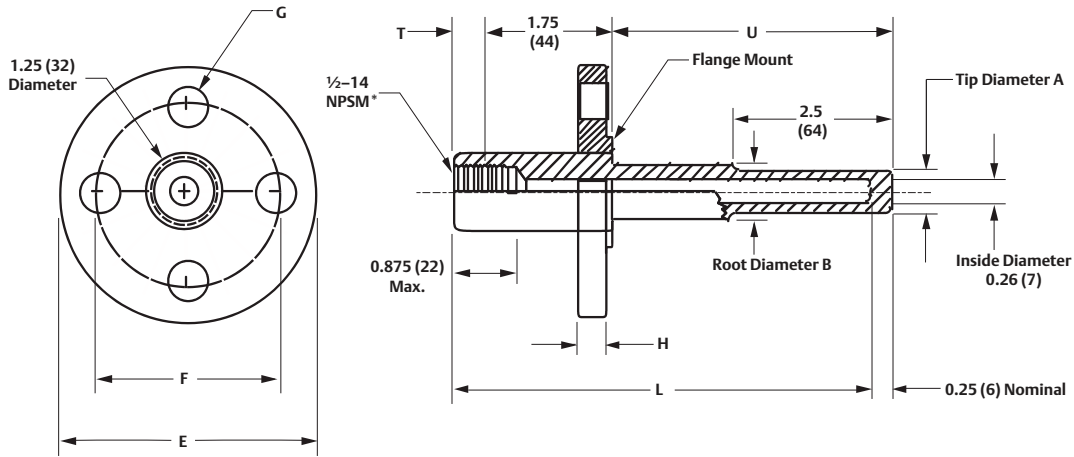
Dimensions are in inches (millimeters).

Size (in.)	O.D. (E)	Circle (F)	# of holes and diameter (G)	Thickness (in.) (H)
<b>Class 150</b>				
1.0	4.25	3.12	four-0.625	0.5625
1.5	5.0	3.88	four-0.625	0.6875
2.0	6.0	4.75	four-0.75	0.75
3.0	7.5	6.00	four-0.75	0.94
<b>Class 300</b>				
1.0	4.88	3.5	four-0.75	0.69
1.5	6.12	4.5	four-0.88	0.81
2.0	6.5	5.0	eight-0.75	0.88

Size (in.)	O.D. (E)	Circle (F)	# of holes and diameter (G)	Thickness (in.) (H)
<b>Class 600</b>				
1.0	4.88	3.5	four-0.75	0.94
1.5	6.12	4.5	four-0.88	1.13
2.0	6.5	5.0	eight-0.75	1.25
<b>Class 900 and 1500</b>				
1.5	7.0	4.88	four-1.12	1.5
<b>Class 2500</b>				
1.5	8.0	5.75	four-1.25	2.0

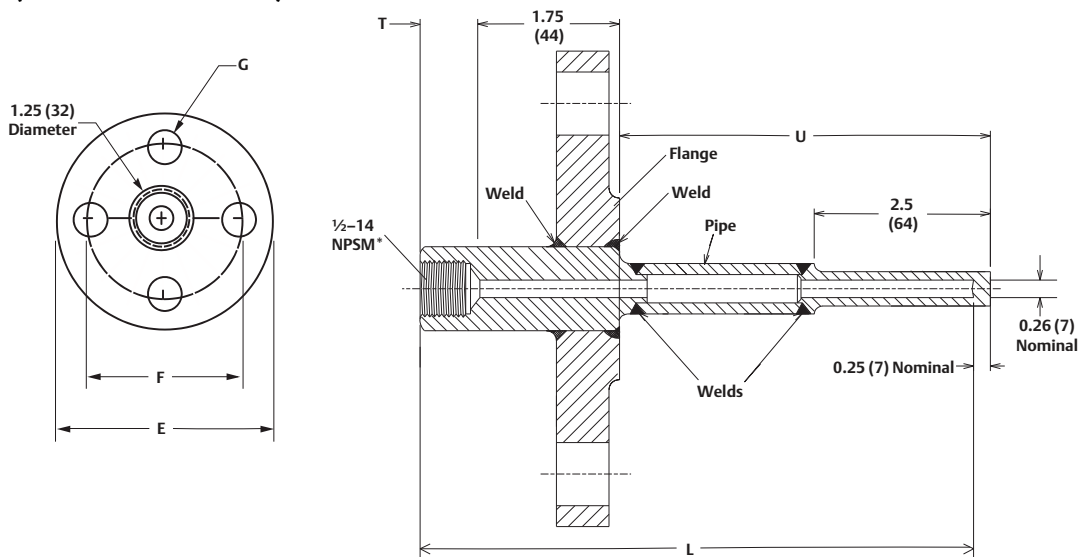
(1) 1/2-14 ANPT threads are available.

**Figure 28. Flange Mounted Thermowells-Stepped<sup>(1)</sup>**



Dimensions are in inches (millimeters).

**Figure 29. Flange Mounted Thermowells - Stepped, For Thermowells with Overall Length greater than 42-in. (3-Piece Construction)<sup>(1)</sup>**



Dimensions are in inches (millimeters).

Size (in.)	O.D. (E)	Circle (F)	# of holes and diameter (G)	Thickness (in.) (H)
<b>Class 150</b>				
1.0	4.25	3.12	four-0.625	0.5625
1.5	5.0	3.88	four-0.625	0.6875
2.0	6.0	4.75	four-0.75	0.75
3.0	7.5	6.00	four-0.75	0.94
<b>Class 300</b>				
1.0	4.88	3.5	four-0.75	0.69
1.5	6.12	4.5	four-0.88	0.81
2.0	6.5	5.0	eight-0.75	0.88

Size (in.)	O.D. (E)	Circle (F)	# of holes and diameter (G)	Thickness (in.) (H)
<b>Class 600</b>				
1.0	4.88	3.5	four-0.75	0.94
1.5	6.12	4.5	four-0.88	1.13
2.0	6.5	5.0	eight-0.75	1.25
<b>Class 900 and 1500</b>				
1.5	7.0	4.88	four-1.12	1.5
<b>Class 2500</b>				
1.5	8.0	5.75	four-1.25	2.0

(1) 1/2-14 ANPT threads are available.

## Product Certifications

### European Directive Information

A copy of the EC Declaration of Conformity can be found at the end of the Quick Start Guide. The most recent revision of the EC Declaration of Conformity can be found at [www.rosemount.com](http://www.rosemount.com).


### Ordinary Location Certification from FM Approvals

As standard, the transmitter has been examined and tested to determine that the design meets the basic electrical, mechanical, and fire protection requirements by FM Approvals, a nationally recognized test laboratory (NRTL) as accredited by the Federal Occupational Safety and Health Administration (OSHA).

#### North America

- E5** FM Explosion proof, Dust-Ignition proof  
Certificate: 0R7A2.AE  
Standards: FM Class 3600: 2011; FM Class 3611: 2004; FM Class 3615: 2006; FM Class 3810: 2005; ANSI/NEMA - 250: 1991  
Markings: **XP** CL I, Div 1, GP B, C, D; **DIP** CL II/III, Div 1, GP E, F, G; T6(-50 °C ≤ T<sub>a</sub> ≤ 155 °C); when installed per Rosemount drawing 00068-0013; Type 4X
- E6** CSA Explosion proof and Dust-Ignition proof  
Certificate: 1063635  
Standards: CSA C22.2 No. 0-M91; CSA C22.2 No. 25-1966; CSA C22.2 No. 30-M1986; CSA C22.2 No. 94-M91; CSA C22.2 No. 142-M1987; CSA C22.2 No. 213-M1987  
Markings: **XP** CL I, Div 1, GP B, C, D; **DIP** CL II/III, Div 1, GP E, F, G; **CL I, Div 2**, GP A, B, C, D; (-50 °C ≤ T<sub>a</sub> ≤ 85 °C); when installed per Rosemount drawing 00068-0033; Type 4X (Spring loaded sensors must be installed in a thermowell to maintain Type 4X and Cl. II/III rating)

#### Europe

- E1** ATEX Flameproof  
Certificate: FM12ATEX0065X  
Standards: EN 60079-0: 2012, EN 60079-1: 2007, EN 60529:1991 +A1:2000  
Markings:  II 2 G Ex d IIC T6...T1 Gb, T6(-50 °C ≤ T<sub>a</sub> ≤ +40 °C), T5...T1(-50 °C ≤ T<sub>a</sub> ≤ +60 °C);

#### Technical Regulations Customs Union (EAC)

- EM** Contact an Emerson Process Management representative for additional information

#### Special Conditions for Safe Use (X):

1. See certificate for ambient temperature range.
2. The non-metallic label may store an electrostatic charge and become a source of ignition in Group III environments.
3. Guard the LCD display cover against impact energies greater than 4 joules.
4. Consult the manufacturer if dimensional information on the flameproof joints is necessary.

#### International

- E7** IECEx Flameproof  
Certificate: IECEx FMG 12.0022X  
Standards: IEC 60079-0:2011, IEC 60079-1:2007-04, IEC 60079-31:2008  
Markings: Ex d IIC T6...T1 Gb, T6(-50 °C ≤ T<sub>a</sub> ≤ +40 °C), T5...T1(-50 °C ≤ T<sub>a</sub> ≤ +60 °C); Ex tb IIIC T130 °C Db, (-40 °C ≤ T<sub>a</sub> ≤ +70 °C); IP66;

#### Special Conditions for Safe Use (X):

1. See certificate for ambient temperature range.
2. The non-metallic label may store an electrostatic charge and become a source of ignition in Group III environments.
3. Guard the LCD display cover against impact energies greater than 4 joules.
4. Consult the manufacturer if dimensional information on the flameproof joints is necessary.

#### Brazil

- E2** INMETRO Flameproof  
Certificate: NCC 12.1147 X  
Standards: ABNT NBR IEC 60079-0: 2008; ABNT NBR IEC 60079-1: 2009  
Markings: Ex d IIC T6/T1 Gb IP66W (-40 °C ≤ T<sub>a</sub> ≤ 65 °C)

#### Special Conditions for Safe Use (X):

1. For information on the dimensions of the flameproof joints the manufacturer shall be contacted.
2. Special care must be taken to ensure that the connection head temperature does not exceed 85 °C, when thermocouples or RTDs are assembled with transmitters listed in Table 1 (certificate).
3. The user should evaluate the use conditions of the rod considering its mechanical and chemical characteristics in order to avoid making efforts that deteriorate the rod or process fluids that may cause its corrosion.

#### Combinations

- KF** Combination of E1 and E6 (not available with Rosemount 0183 sensors)

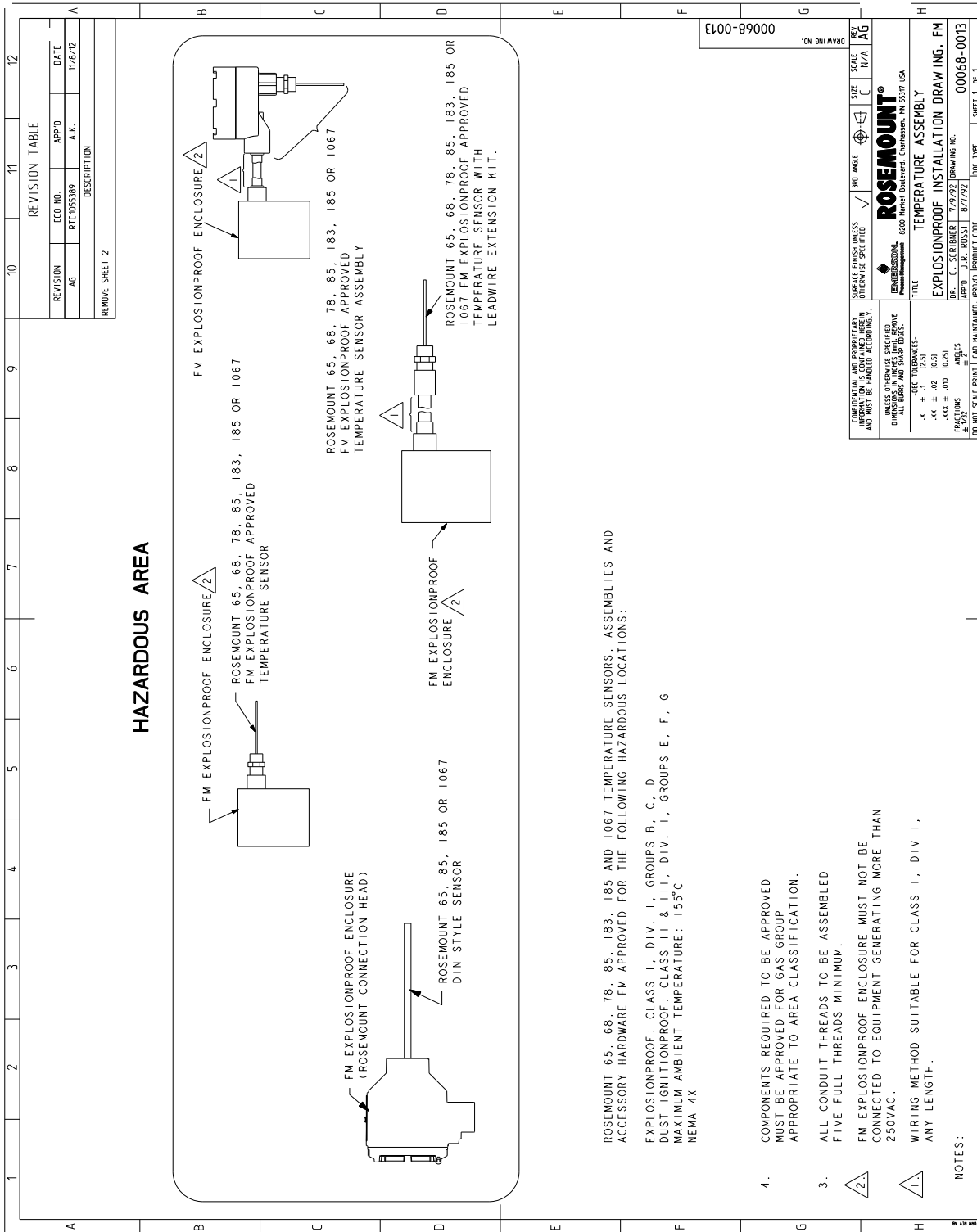
**Table 33. Available Safety Approvals with Connection Heads**

Refer to this table to determine which approvals are available with each connection head.

Code	Connection head	Approval code				
		E1	E2	E5	E6	E7
R	Aluminum connection head, six terminals, flat cover, unpainted	Y	N	Y	Y	N
T	Aluminum connection head, six terminals, extended cover, unpainted	N	N	Y	Y	N
P	Aluminum connection head, six terminals, flat cover, painted	Y	N	Y	Y	N
L	Aluminum connection head, six terminals, extended cover, painted	N	N	Y	Y	N
N	Sensor only with 6-in. PTFE-insulated, 24 gauge leadwires	Y	Y	Y	Y	Y
D	Rosemount aluminum connection head with 1/2-in. entries	Y	Y	Y	Y	Y
C	Polypropylene connection head	N	N	N	N	N
G	Rosemount SST connection head with 1/2-in. entries	Y	Y	Y	Y	Y

Factory Mutual (FM) Explosion-Proof

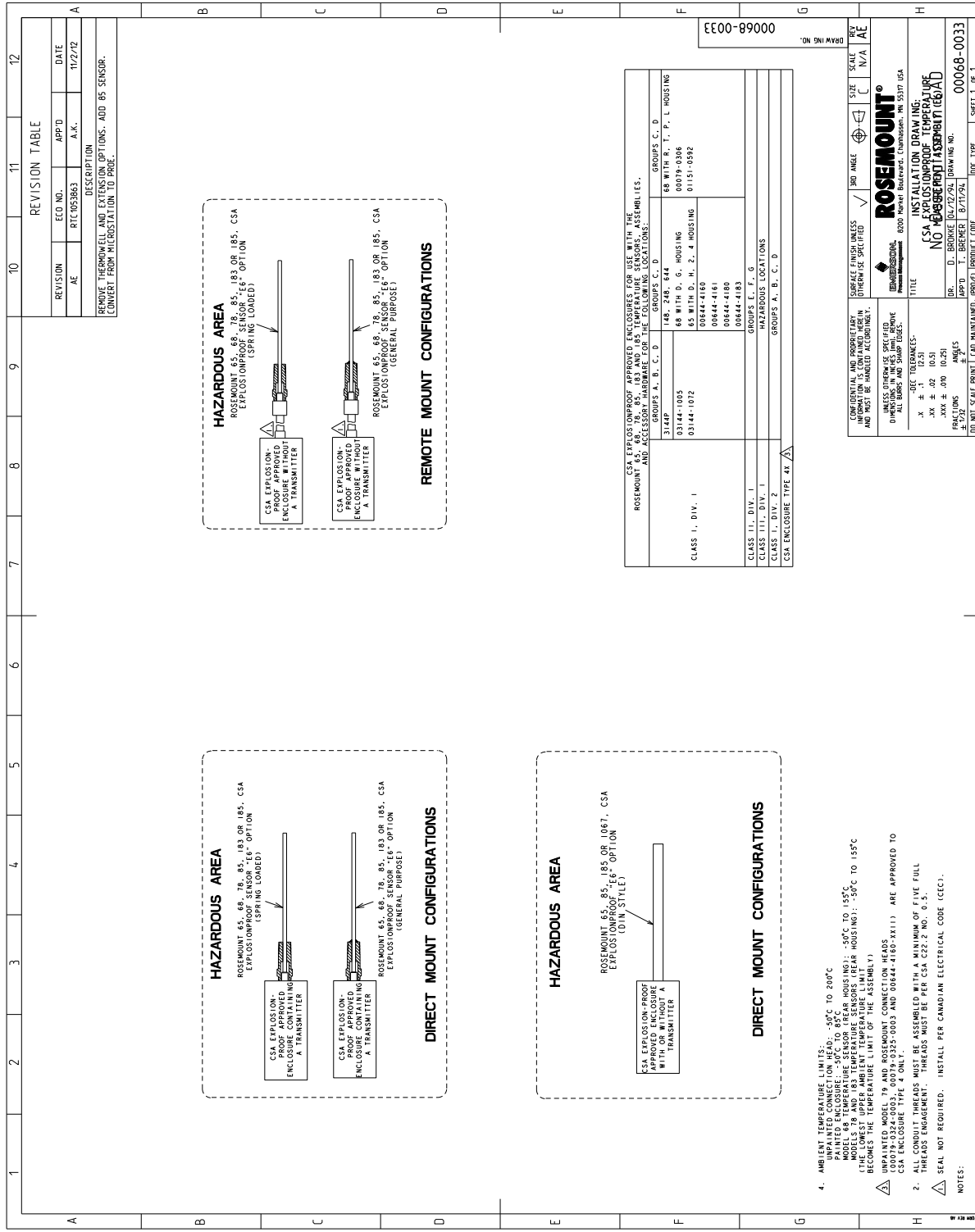
Figure 30. Installation Drawing 00068-0013, Rev. AG





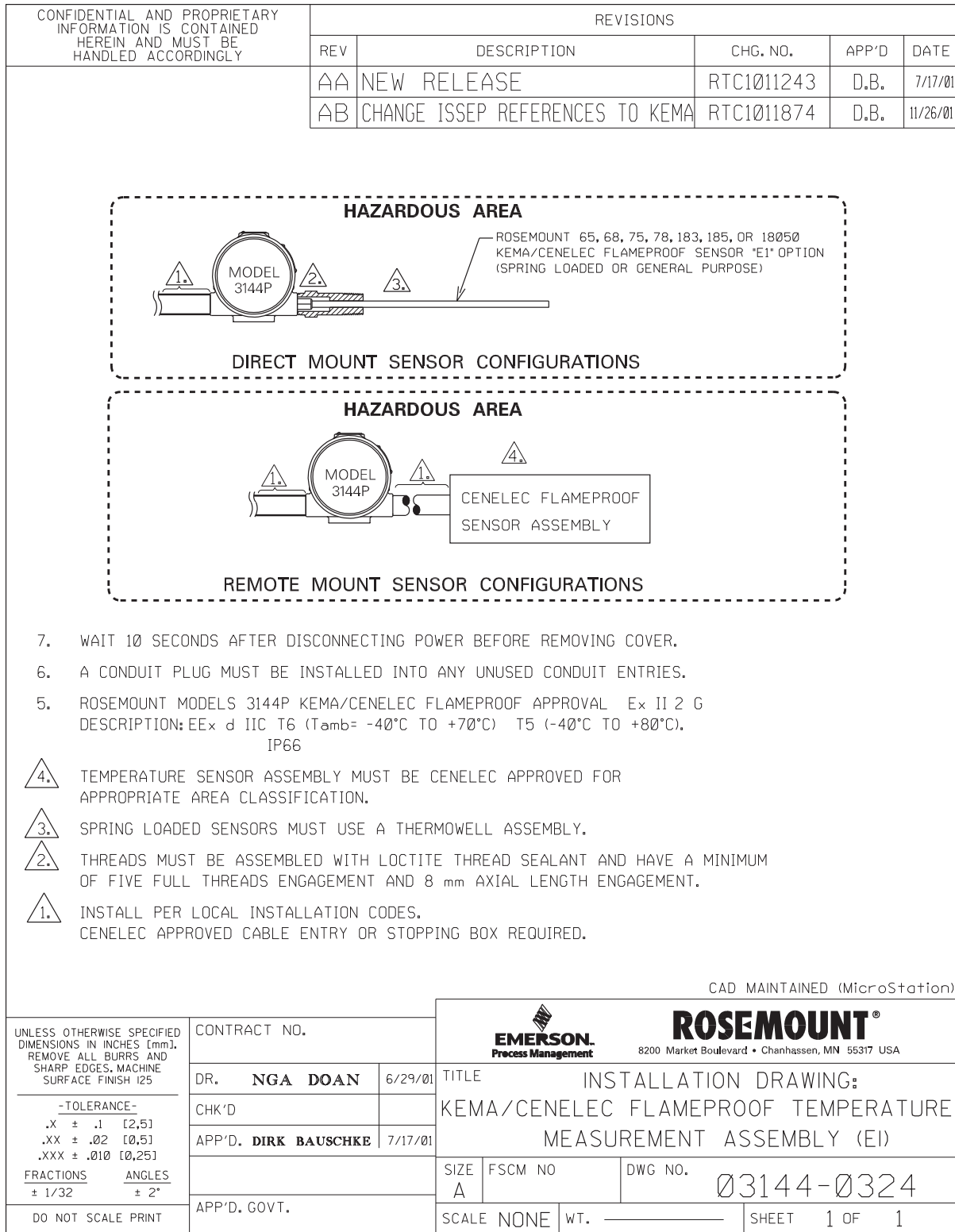
Canadian Standards Association (CSA) Explosion-Proof

Figure 31. Installation Drawing 00068-0033, Rev. AE



ATEX Flameproof

Figure 32. Installation Drawing 03144-0324, Rev. AB





**Emerson Process Management  
Rosemount Inc.**

8200 Market Boulevard  
Chanhassen, MN 55317 USA  
T (U.S.) 1-800-999-9307  
T (International) (952) 906-8888  
F (952) 906 8889  
[www.rosemount.com](http://www.rosemount.com)

**Emerson Process Management Asia Pacific  
Pte Ltd**

1 Pandan Crescent  
Singapore 128461  
T +65 6777 8211  
F +65 6777 0947  
Service Support Hotline: +65 6770 8711  
Email: [Enquiries@AP.EmersonProcess.com](mailto:Enquiries@AP.EmersonProcess.com)  
[www.rosemount.com](http://www.rosemount.com)

**Emerson Process Management**

Blegistrasse 23  
P.O. Box 1046  
CH 6341 Baar  
Switzerland  
T +41 (0) 41 768 6111  
F +41 (0) 41 768 6300  
[www.rosemount.com](http://www.rosemount.com)

**Emerson FZE**

P.O. Box 17033  
Jebel Ali Free Zone  
Dubai UAE  
Tel +971 4 811 8100  
Fax +971 4 886 5465  
[www.rosemount.com](http://www.rosemount.com)

**Emerson Process Management  
Latin America**

1300 Concord Terrace, Suite 400  
Sunrise, Florida 33323 USA  
Tel + 1 954 846 5030  
[www.rosemount.com](http://www.rosemount.com)

Standard Terms and Conditions of Sale can be found at [www.rosemount.com/terms\\_of\\_sale](http://www.rosemount.com/terms_of_sale).

The Emerson logo is a trade mark and service mark of Emerson Electric Co.  
Rosemount, and the Rosemount logotype are registered trademarks of Rosemount Inc.  
Complete Point Solution and Tri-Clamp are trademarks of Rosemount Inc.  
All other marks are the property of their respective owners.

© 2015 Rosemount Inc. All rights reserved.