

Submersion/Insertion Toroidal Sensor

For additional information, visit our website
at www.emersonprocess.com/raihome/liquid/.

CAUTION
SENSOR/PROCESS
APPLICATION COMPATIBILITY

The wetted sensor materials may not be compatible with process composition and operating conditions. Application compatibility is entirely the responsibility of the user.

CAUTION



Before removing the sensor, be absolutely certain that the process pressure is reduced to 0 psig and the process temperature is lowered to a safe level!

SPECIFICATIONS

Wetted Material: PEEK (glass-filled), EPDM gasket

Temperature: 248°F (120°C) maximum

Pressure: 295 psig (2135 kPa abs)

INSTALLATION

Keep at least 1.5 in. (40 mm) between the sensor and pipe walls. If the clearance is too small, calibrate the sensor in place. Ensure that the sensor is completely submerged in the liquid. Mounting the sensor in a vertical pipe run with the flow from bottom to top is best. If the sensor must be installed in a horizontal pipe run, mount the sensor in the 3 o'clock or 9 o'clock position.

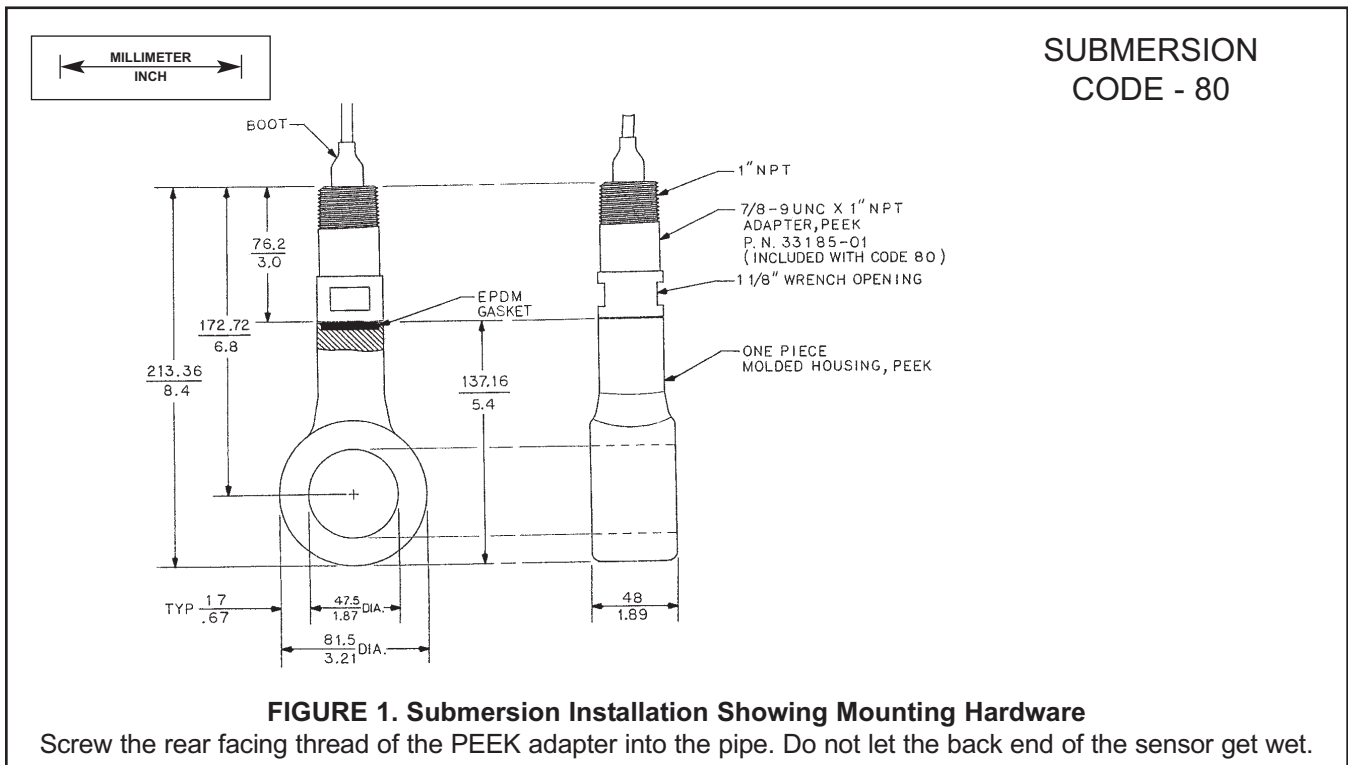

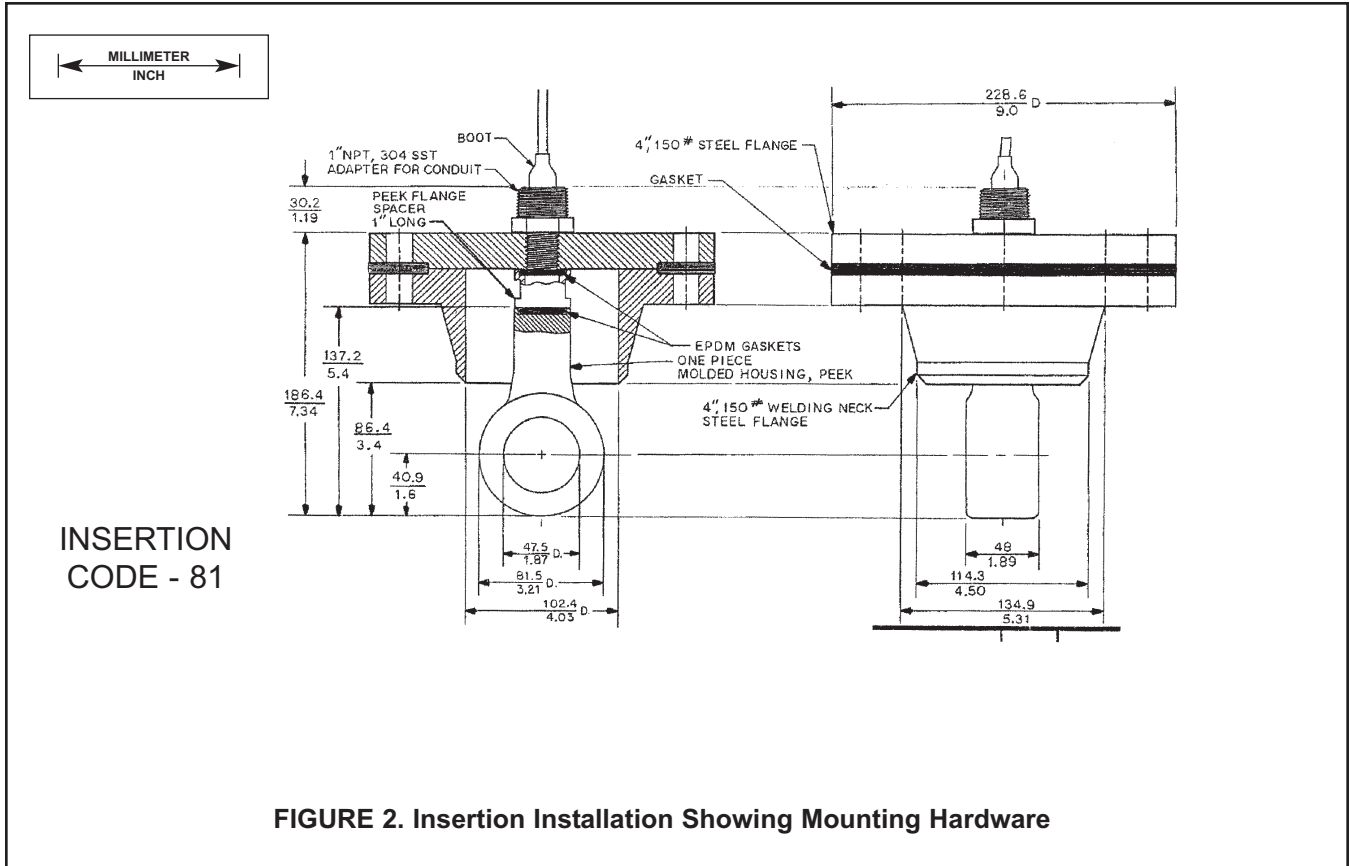

WIRING

Keep sensor wiring away from ac conductors and high current demanding equipment. **Do not cut cable.** Cutting the cable may void the warranty.

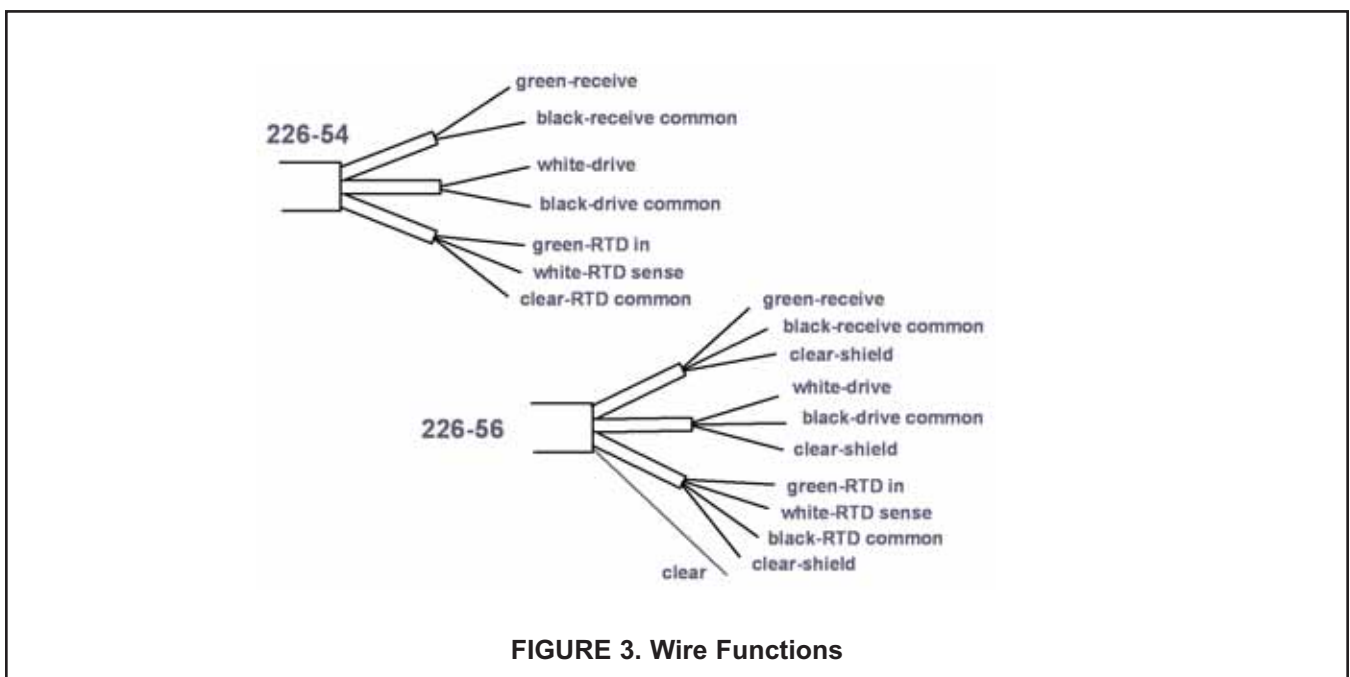

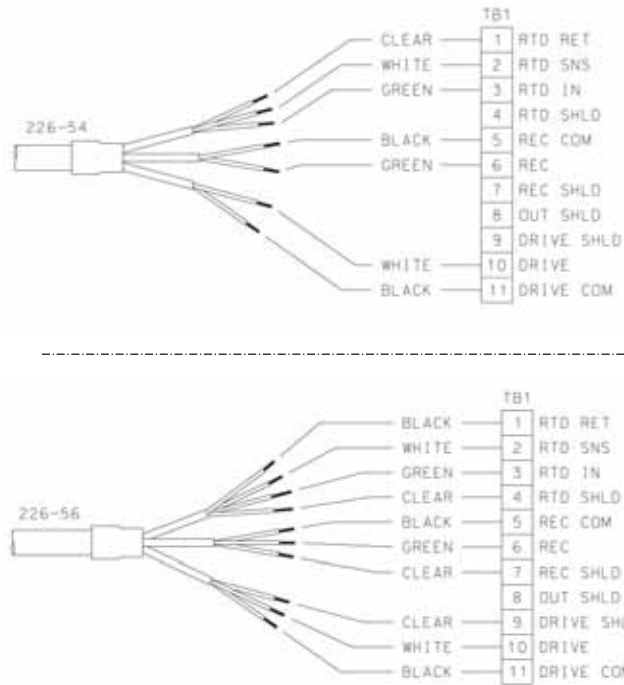

FIGURE 4. Wiring 226-54 and 226-56 sensors to Model 1056 and 56 analyzers

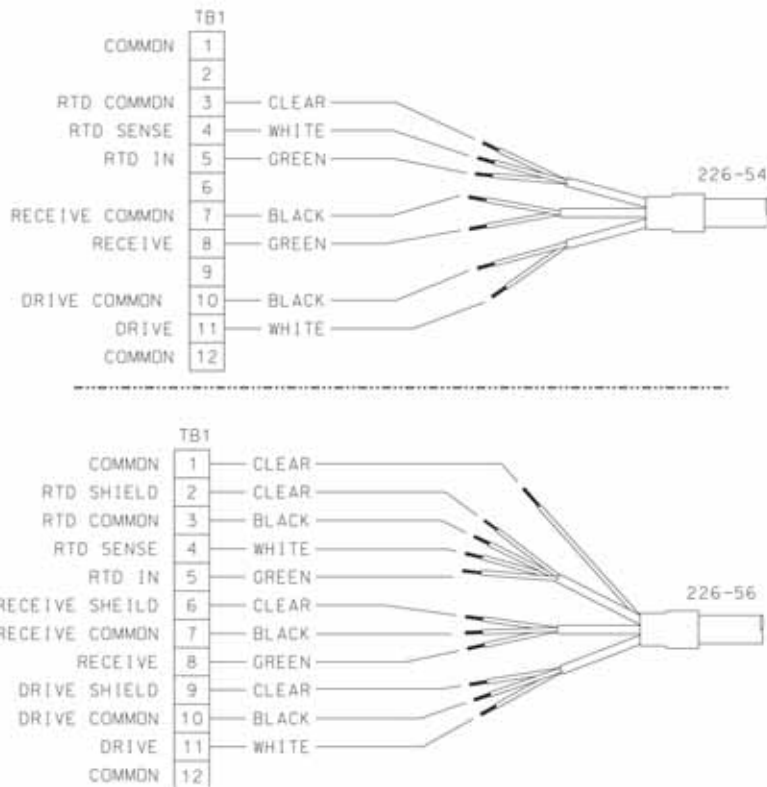

FIGURE 5. Wiring 226-54 and 226-56 sensors to Model 54eC analyzer

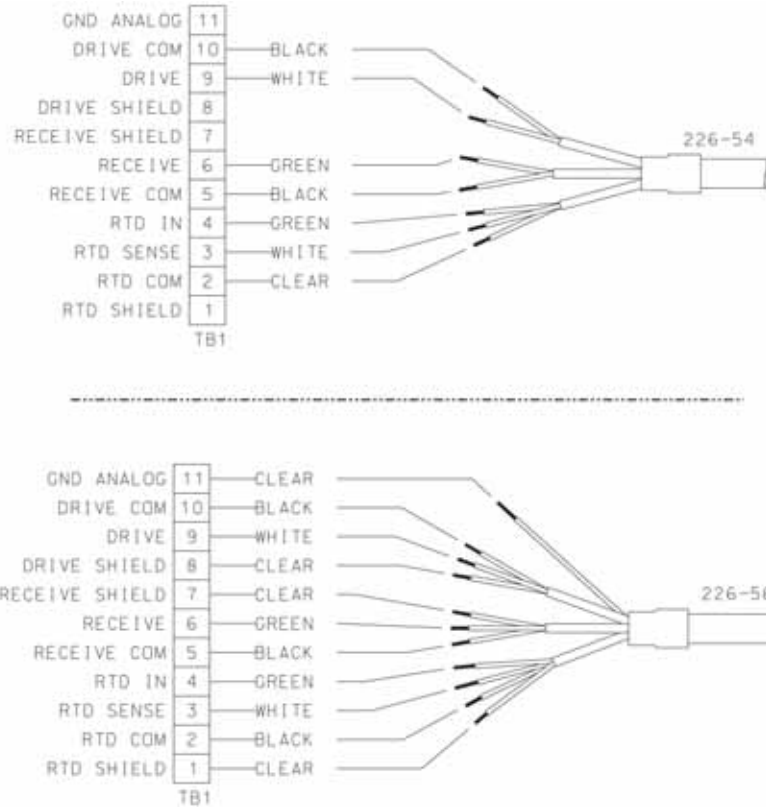

FIGURE 6. Wiring 226-54 and 226-56 sensors to Model Xmt-T panel mount transmitter

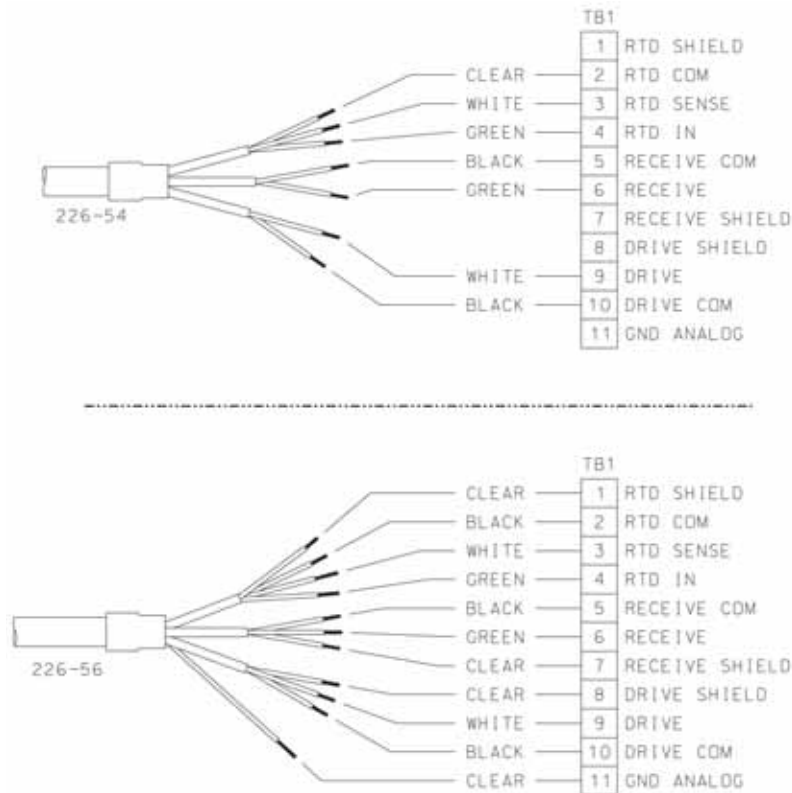

FIGURE 7. Wiring 226-54 and 226-56 sensors to Model Xmt-T pipe/wall mount transmitter

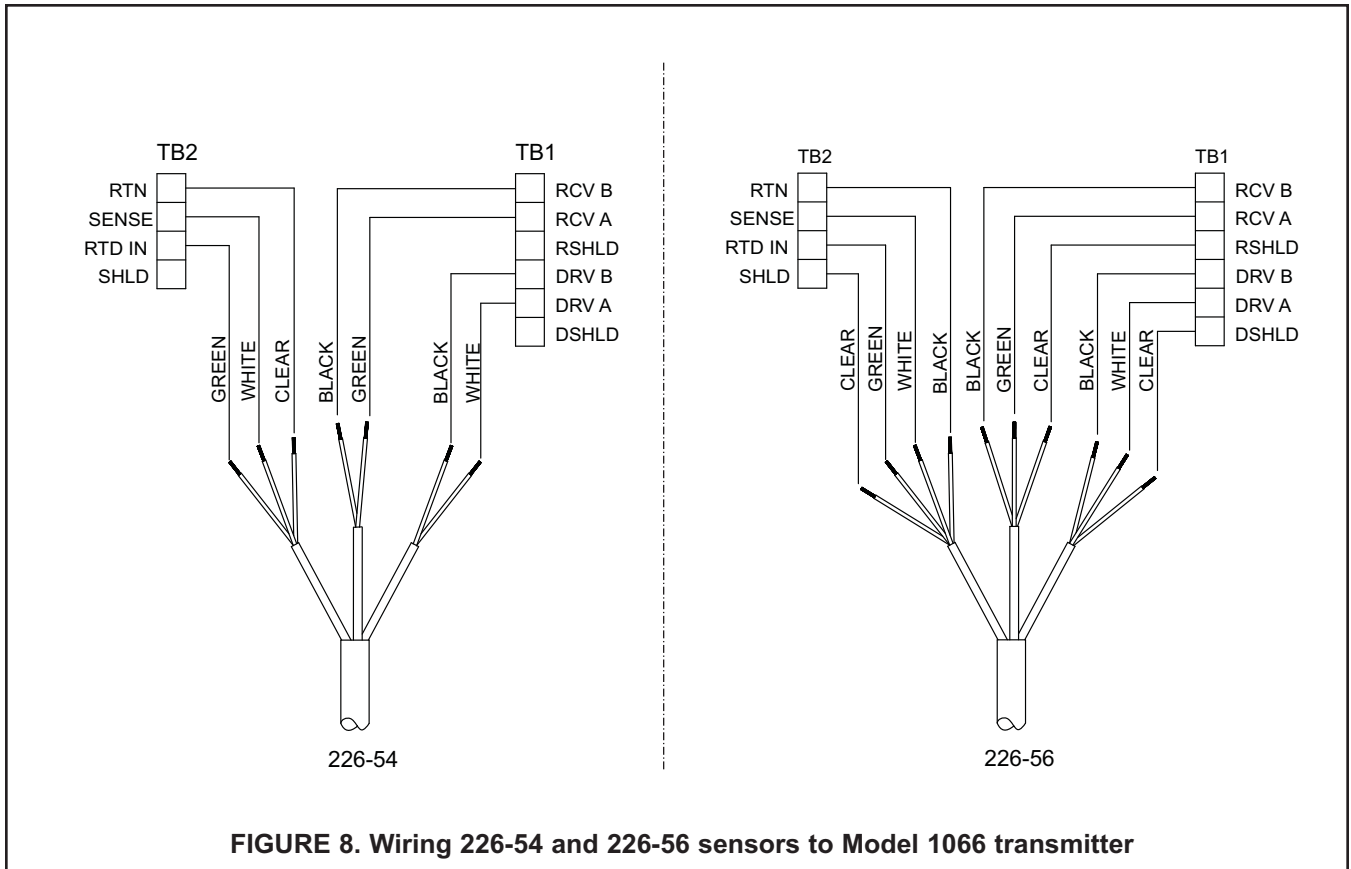

FIGURE 8. Wiring 226-54 and 226-56 sensors to Model 1066 transmitter

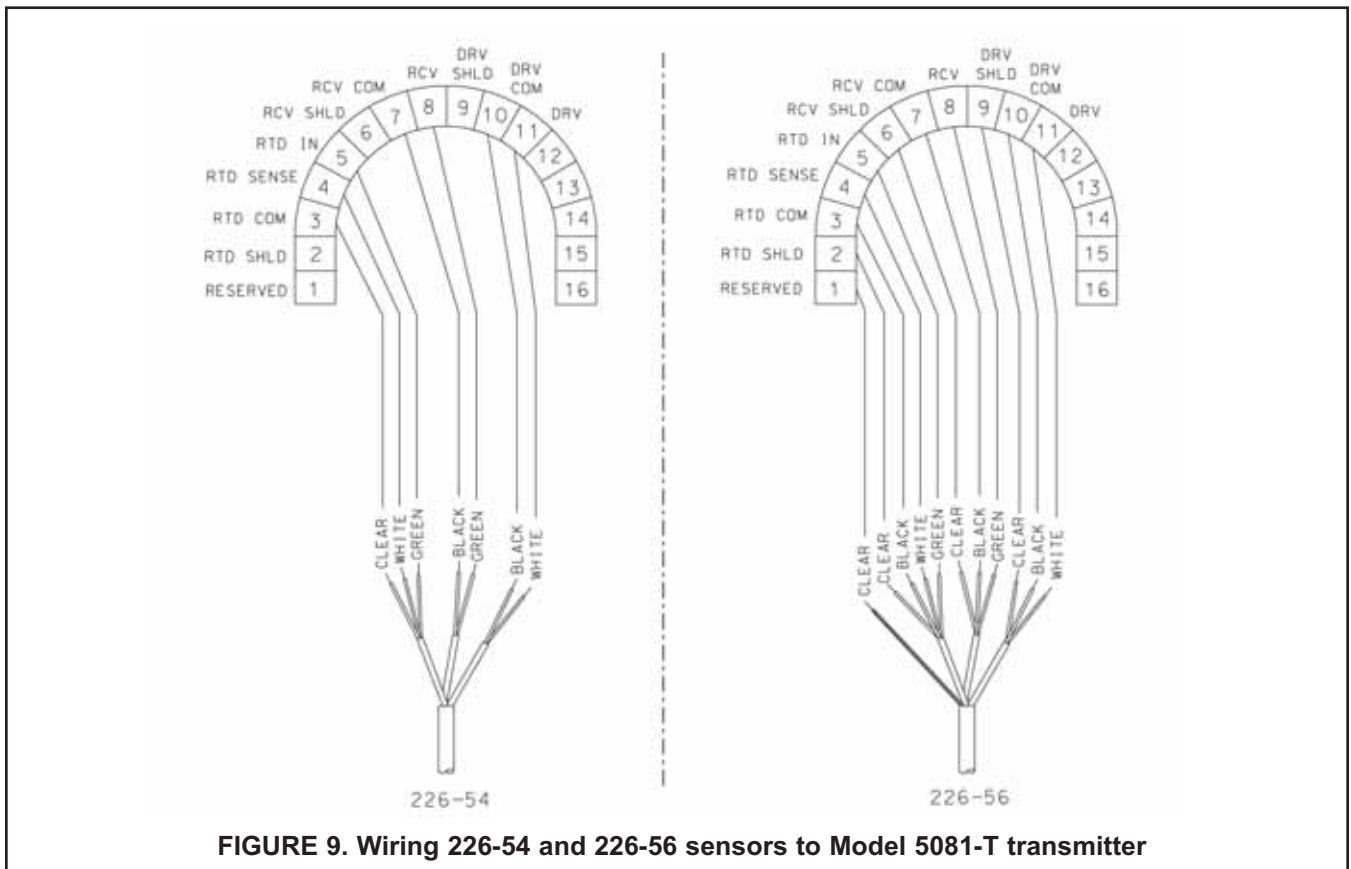

FIGURE 9. Wiring 226-54 and 226-56 sensors to Model 5081-T transmitter

WIRING THROUGH A REMOTE JUNCTION BOX

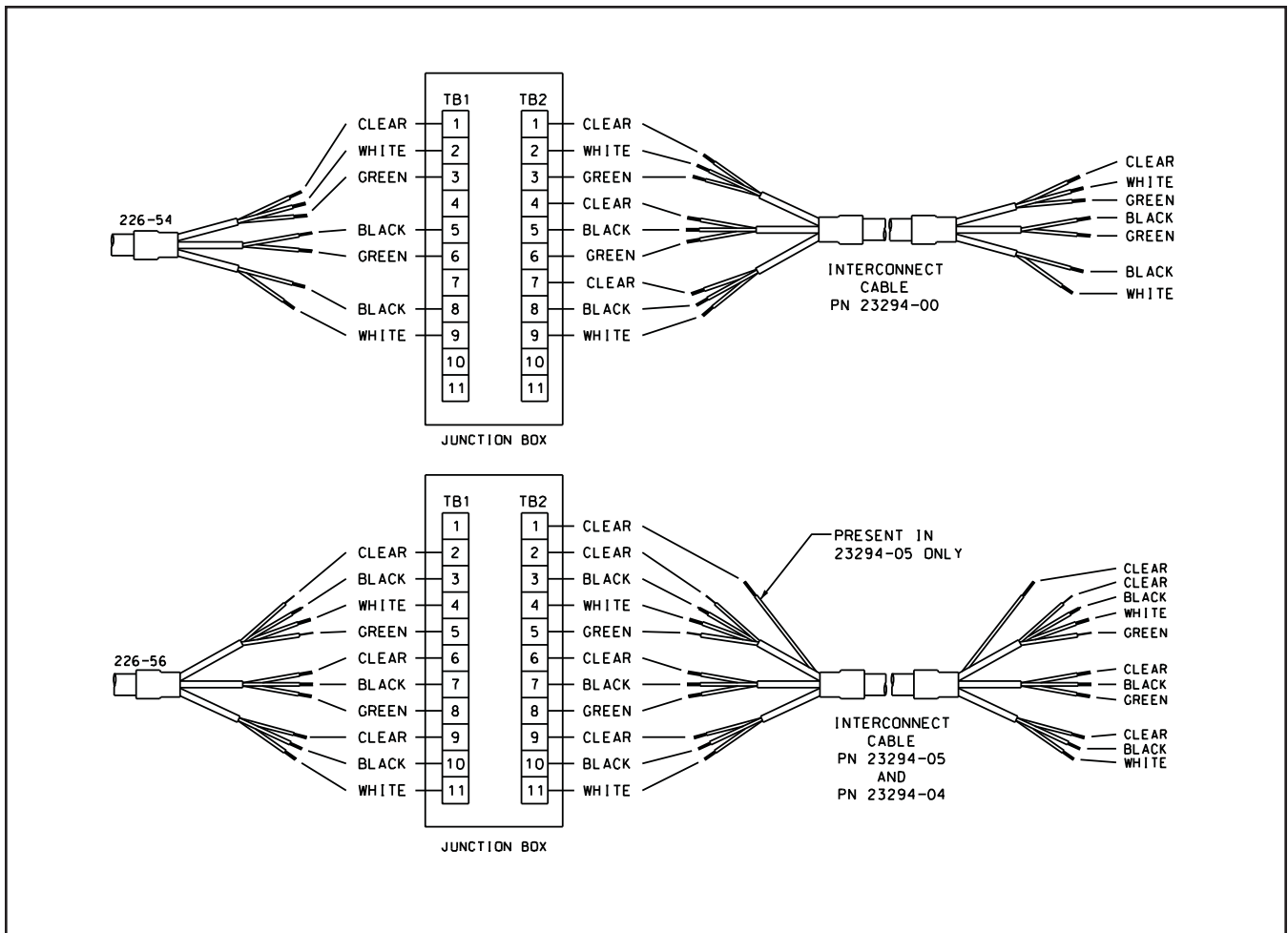

FIGURE 10. Wiring sensors through a remote junction box

Wire sensors point to point. For wiring at the analyzer end, refer to the appropriate analyzer wiring diagram. For interconnecting cable 23294-00, use the 2265-54 wiring diagram. For interconnecting cable 23294-04 and 23294-05, use the 226-56 wiring diagram.

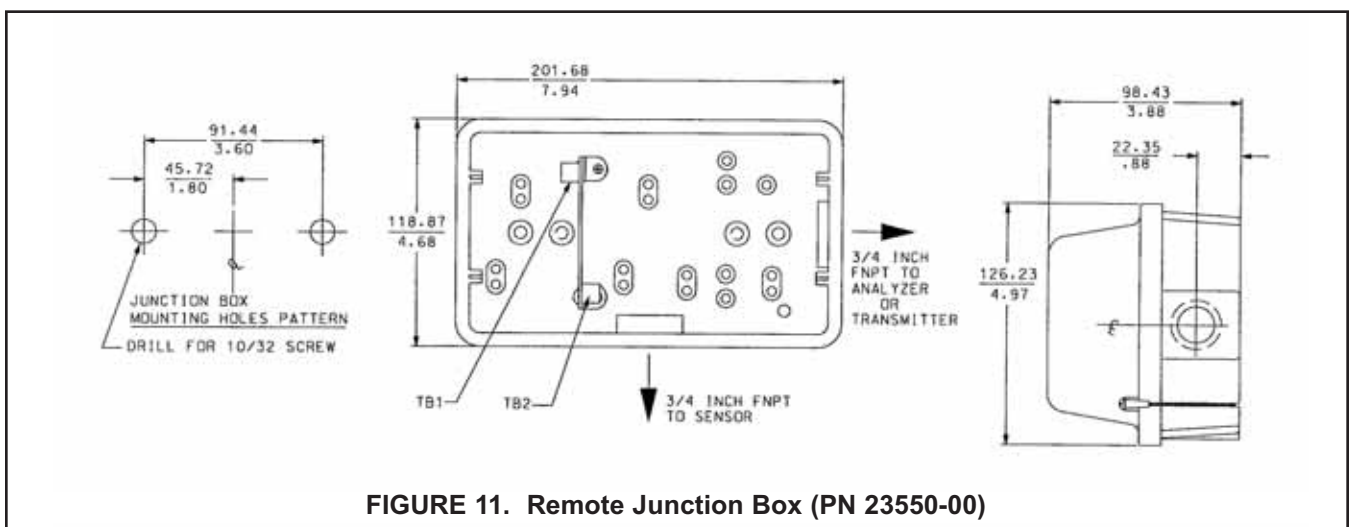
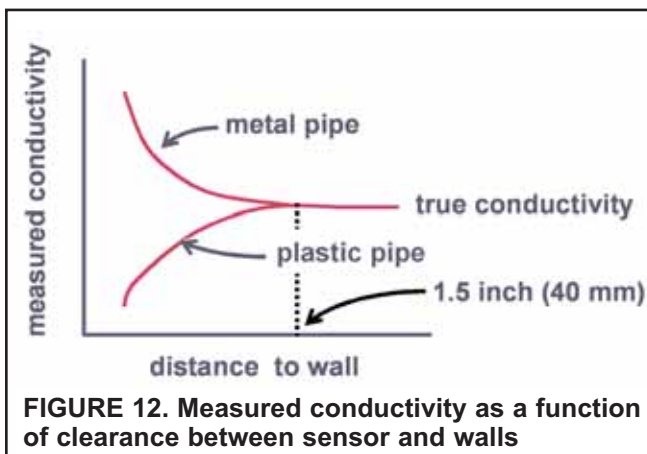

FIGURE 11. Remote Junction Box (PN 23550-00)

CALIBRATION

The nominal cell constant of the Model 226 sensor is 1.2/cm. The error in the cell constant is about $\pm 10\%$, so conductivity readings made using the nominal cell constant will have an error of at least $\pm 10\%$. Wall effects, discussed below, will likely make the error greater. For higher accuracy, the sensor must be calibrated.

Wall effects arise from the interaction between the current induced in the sample by the sensor and nearby pipe or vessel walls. As Figure 12 shows, the measured conductivity can either increase or decrease depending on the wall material. Because wall effects do not disappear until the Model 226 sensor is at least 1.5 inch (40 mm) away from the nearest wall, wall effects are present in most installations. Correcting for them is an important part of calibration.



Conductivity sensors are calibrated against a solution of known conductivity (a standard) or against a previously calibrated referee sensor and analyzer. **If wall effects are present**, calibrating a toroidal sensor with a standard solution is possible only if the vessel holding the standard has exactly the same dimensions as the process piping. If the Model 226 sensor is installed in a tee, duplicating the process environment in the laboratory or shop might be possible. Otherwise, cali-

bration against a standard solution is probably impractical. The alternative is to calibrate the sensor in place against a referee sensor and analyzer, ideally while both sensors are simultaneously measuring the same process liquid. If this is not practical, calibrate the process sensor against the results of a measurement made on a grab sample.

For more information about calibrating toroidal conductivity sensors, refer to application sheet ADS 43-025 available on the Rosemount Analytical website.

MAINTENANCE

▲ CAUTION

Be sure sensor has been cleaned of process liquid before handling.

Generally, the only maintenance required is to keep the opening of the sensor clear of deposits. Cleaning frequency is best determined by experience.

TROUBLESHOOTING

PROBLEM	PROBABLE CAUSE	SOLUTION
Off-scale reading	Wiring is wrong.	Verify and correct wiring.
	RTD is open or shorted.	Check the RTD for open or short circuits. See Figure 13.
	Sensor is not in process stream.	Confirm that the sensor is fully submerged in the process stream. See installation section.
	Sensor is damaged.	Perform isolation checks. See Figure 13.
Noisy reading	Sensor is improperly installed in the process stream.	Confirm that the sensor is fully submerged in the process stream. See installation section.
	Sensor cable is run near high voltage conductors.	Move cable away from high voltage conductors.
	Sensor cable is moving.	Keep sensor cable stationary.
Reading seems wrong (lower or higher than expected)	Bubbles are trapped in the sensor, particularly in the toroid opening.	Install the sensor in a vertical pipe run with the flow against the toroid opening. Increase flow if possible.
	Sensor is not completely submerged in the process stream.	Confirm that the sensor is fully submerged in the process stream. See installation section.
	Cell constant is wrong. Wall effects are present.	Calibrate the sensor in place in the process piping. See calibration section.
	Wrong temperature correction algorithm is being used.	Check that the temperature correction is appropriate for the sample. See analyzer manual for more information.
	Temperature reading is inaccurate.	Disconnect the RTD leads (Figure 13) and measure the resistance between the in and common leads. Resistance should be close to the value in Table 1.
	Slow temperature response to sudden changes in temperature.	Use an RTD in a metal thermowell for temperature compensation.
Sluggish response	Sensor is installed in a dead area in the piping.	Move sensor to a location more representative of the process liquid.
	Slow temperature response to sudden changes in temperature.	Use an RTD in a metal thermowell for temperature compensation.

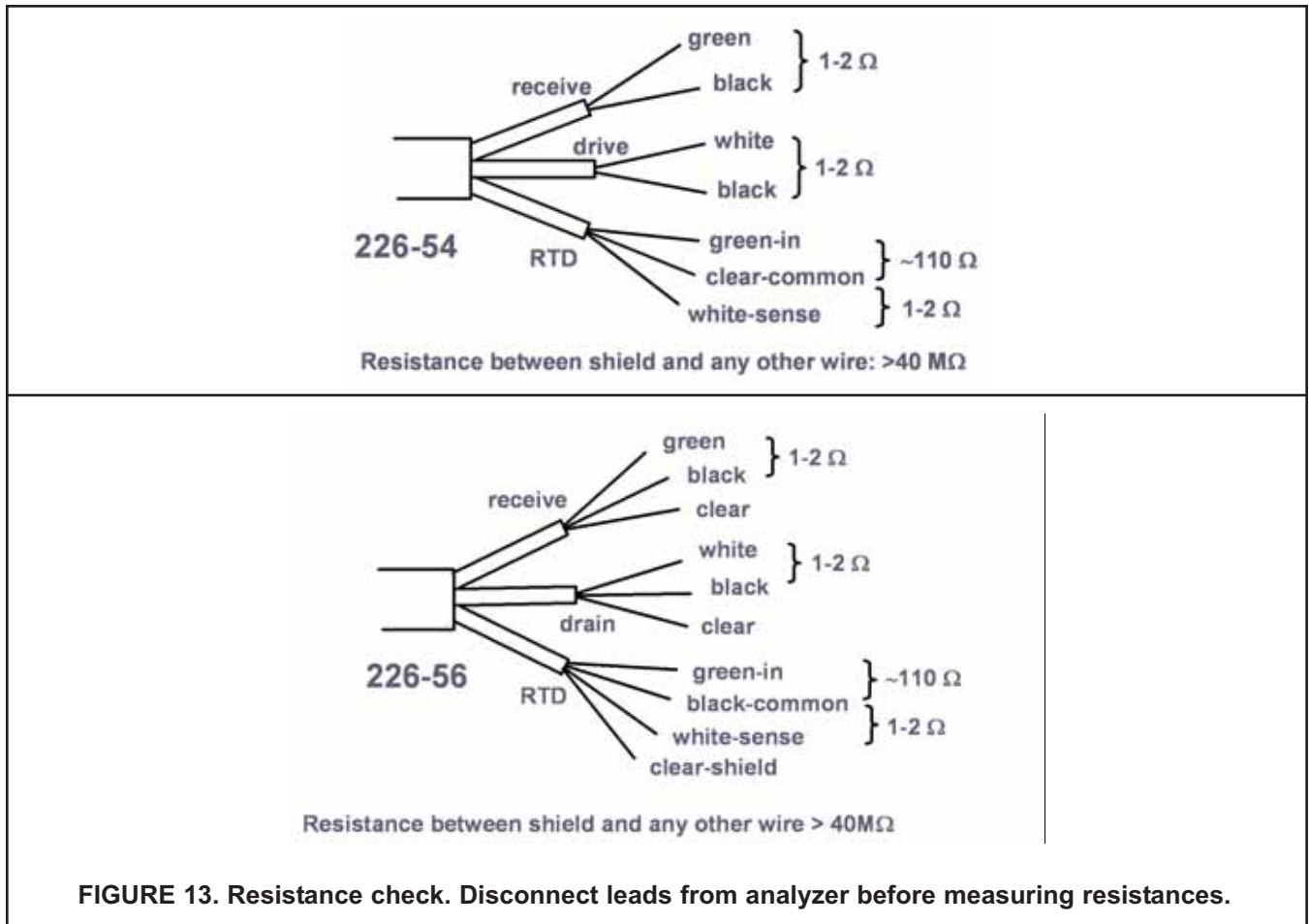

TABLE 1.

Temperature	Resistance
10°C	103.9 Ω
20°C	107.8 Ω
25°C	109.7 Ω
30°C	111.7 Ω
40°C	115.5 Ω
50°C	119.4 Ω

NOTES:

NOTES:



*The right people,
the right answers,
right now.*

ROSEMOUNT ANALYTICAL
CUSTOMER SUPPORT CENTER
1-800-854-8257



ON-LINE ORDERING NOW AVAILABLE ON OUR WEB SITE
<http://www.raihome.com>



Credit Cards for U.S. Purchases Only.



Emerson Process Management

2400 Barranca Parkway
Irvine, CA 92606 USA
Tel: (949) 757-8500
Fax: (949) 474-7250
<http://www.raihome.com>

