



Digital temperature controller

Micro-Controller X Socket type



Type: PXF4

Operation Manual

Safety Instructions

Please read the safety instructions thoroughly before using the equipment. The safety instructions must be observed by every user to prevent accidents. Failure to comply with the instructions contained in this manual may reduce the safety of the equipment.

The safety instructions are classified into “Warning” and “Caution” according to the following interpretations:

 WARNING	Mishandling may lead to serious injury or death.
 CAUTION	Mishandling may result in personal injury or damage to the property.

WARNING

Installation and wiring

- This equipment is intended to be used under the following conditions.

Ambient temperature	-10 to 50°C
Operating humidity	90%RH or less (Non condensation)
Installation category	II
Pollution degree	2 — According to IEC 61010-1
Recommended fuse	250 V AC, 0.1 A, T (Time-Lag) (100 to 240 V AC), 400 V DC/AC, 1 A, T (Time-Lag) (24 V DC/AC)
Usage environment	Indoor use

- For 24 V DC/AC power supply model, if the equipment is connected to the Safety Extra Low Voltage (SELV) circuit, a basic insulation* must be provided between the SELV circuit and the power input terminals. Otherwise, the power input terminals must be connect to Extra Low Voltage (ELV) circuit so as to prevent the electric shock.

About safety standard

Please observe the following instructions to meet the requirements of safety standard. Failure to observe these instructions violates safety standards. (This product is not a safety equipment.)

- Install a recommended fuse, which is specified in the instruction manual, between the external main power (mains circuit) and this equipment.
- If accessible Safety Extra Low Voltage (SELV) circuits are to be connected to Signal input terminal, SSR Drive output terminal or Current output terminal, ensure to provide a basic insulation* between the SELV circuits and these terminals (For example, use transformer which has a basic insulation* or higher degree of insulation).
- Whole this equipment must be mounted in an enclosure in order to prevent the electric shock and spread of fire.
- Be sure to install an appropriate external protective circuit to prevent excessive temperature rise etc.
- When performing wiring work, be sure to turn the power off and to wear protection gloves or safety glasses, to prevent an electric shock.
- Do not use this equipment for the measurement of circuits which falls under measurement categories II, III, or IV.
- Do not use this equipment for measurement of signals to which a voltage over 30 VRMS or over 60 V DC is applied.

* The basic insulation requires a clearance at least 1.5 mm and a creepage of at least 3.0 mm. If such insulation is not provided, the UL61010 and EN61010 safety compliance may become invalid.

- If the voltage exceeds 50 V DC (which is called as hazardous voltage), install a basic insulation between all terminals and the ground, and supplementary insulation on the digital outputs.
Note that the insulation class for this equipment is as follows. Before installing, please confirm that the insulation class for equipment meets usage requirements.

————— Basic insulation (1500 V AC)
————— Functional insulation (500 V AC)
..... No insulation

Power supply (100 to 240 V AC)	Internal circuit
Power supply (24 V DC/AC)	
Control output 1 (relay contact)	Process value input
Alarm output 1 and 2 (relay contact)	Control output 1 (SSR drive, current)

- In case where damage or problems with this equipment may lead to serious accidents, install appropriate external protective circuits.
- As this equipment has no power switch or fuse, install them separately as needed.
If you install a fuse, be sure to place it between the main power switch and this equipment. (Main power switch: double-pole breaker, fuse rating: 250V, 1A)
- A power switch or a circuit breaker should be installed within the power supply facility.
- A power switch or a circuit breaker should be properly installed within easy reach of an operator.
- A power switch or a circuit breaker should be identified as the one for this product.
- Electrical wiring must be made by the qualified personnel only and in accordance with your local and national standards.
- For power supply wiring, use a wire equivalent equal to 600 V vinyl insulated wire or higher level.
- To prevent damage and failure of the equipment, provide the rated power voltage.
- To prevent shock and equipment failure, do not turn the power ON until all wiring is complete.
- Before turning on power, confirm that clearance space has been secured to prevent shock or fire.
- Do not touch the terminal while the machine is on. Doing so risks shock or equipment errors.
- Never disassemble, convert, modify or repair this equipment. Doing so risks abnormal operation, shock or fire.
- If any failure occurs, please contact the manufacturer and return the product.
- Output relay is the part has a limited life. When output relay contact comes to the end of its life, it might remain on-state, or off-state. For safety, use a protective circuit outside.
- The factory default setting of this equipment is as follows. Change the setting as necessary so as the equipment to meet your application. Please note that the improper settings may result in overheat or unexpected damage. For the details of operation, refer to this manual.
 - Control output 1: heating control
 - Alarm output 1 to 2 (optional): No function
- Symbols on the instrument
 - ⚠: Read this instruction manual thoroughly before using the product, and use the product safely.

Maintenance

- When installing or removing the equipment, turn the power OFF. Otherwise, shock, operational errors or failures may be caused.
- Periodic maintenance is recommended for continuous and safe use of this equipment.
- Some parts installed on this equipment have a limited life and/or may deteriorate with age.
- The warranty period for this unit (including accessories) is three years after the date of manufacture, if the product is used properly.

Caution

Installation

- Please avoid installing in the following locations.
 - Locations in which the ambient temperature falls outside the range of -10 to 50 °C when equipment is in use.
 - Locations with rapid temperature changes, leading to dew condensation
 - Locations with corrosive gases (especially sulfide gas, ammonia, etc.) or flammable gases.
 - Locations with vibration or shock directly. (Vibration and shock may cause output relay malfunction.)
 - Locations in contact with water, oil, chemicals, steam or hot water. (If the equipment gets wet, there is a risk of electric shock or fire, so have it inspected by Fuji distributor.)
 - Locations with high concentrations of atmospheric dust, salt or iron particles.
 - Locations with large inductive interference, resulting in static electricity, magnetic fields or noise
 - Locations in direct sunlight.
 - Locations that build up heat from radiant heat sources, etc.
- Recommended site conditions
 - A place where the ambient humidity during operation is between 45 to 85% RH.

About EMC standard

- This equipment is a class A, for industrial locations, equipment. Do not use this equipment in domestic establishment, such as residential areas, or it may cause radio interference. If you use this equipment in domestic locations, take adequate measures on the outside of the equipment to reduce radio interference.
- Under the requirement of EMC standard, the maximum length of external cable including a sensor to be connected to this equipment is 30 m. Do not connect the sensor longer than 30 m.

Panel mounting

- Insert the controller unit into the panel cutout from the front, and then put the mounting bracket from the rear. The mounting bracket should be pushed in until the controller is securely fixed to the panel. If there is a slight gap remaining, gently tighten the two screws until the gap disappears. (Make sure not to over tighten the screws, as doing so may result in the mounting bracket separating from the stopper.)
- The front of this equipment is waterproof in compliance with NEMA-4X standards (IP66- equivalent). To effect waterproof, the included packing is shall be attached between the controller and the panel according to the guidelines below. (Incorrect attachment may cause the equipment to lose its waterproof capabilities.)
 - (1) As shown in Fig. 1, insert to the panel after attaching the packing to the equipment case.
 - (2) As shown in Fig. 2, tighten the screws of the mounting bracket so that no gaps can remain between the equipment face, the packing and the panels. Once finished, confirm that there are no changes in shape such as displaced or improperly-fitted packing, etc. as shown in Fig. 3

< Attachment on vertical surface (Horizontal attachment) >

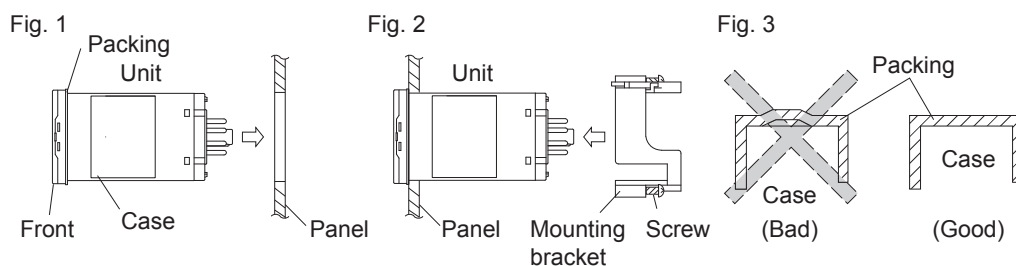

- If the panel does not have enough strength, gaps may develop between the packing and the panel to lose waterproofing capabilities.
- In order to aid heat dissipation, do not block the sides of the equipment.

- Do not block the air vents on the top and bottom of the case.

Wiring

- For thermocouple input, use the designated compensation lead; for RTD input, use wires with small lead wire resistance and without any resistance difference among the three wires.
- To avoid noise conductor effects, input signal wires should be separated from electric power lines or load lines.
- Input signal wire and output signal wire should be separated each other. And both should be shield wire.
- If there is a lot of noise from the power source, adding an insulation transducer and using a noise filter is recommended. Always attach a noise filter to a panel that is grounded securely, and keep the wiring between the noise filter output side and the measuring equipment power terminal wiring to a minimum length. Please do not attach fuses and switches, etc. to the noise filter output wiring; otherwise the filter's effectiveness will be decreased.
- Twisting the power wires is effective when connecting the wires. (The shorter the pitch of the twist, the more effective the connection is against noise.)
- Operation preparation time is required for the contact output when power is turned on. If using it as a signal to an external interlock circuit, please couple it with a delayed relay.
Concerning the output relay, connecting the maximum rated load will shorten the product's life; so please attach an auxiliary relay. If the output operation frequency is high, selecting a SSR drive output type is recommended.
[Proportionate cycles] Relay output: 30 seconds or more, SSR drive output:
1 second or more
- When inductive loads such as magnetic opening/closing equipment, etc. as relay output equipment are connected, use of a surge absorber is recommended in order to protect the contacts against opening/closing surges and to ensure long-term use.

Recommended specification for the surge absorber

Voltage	Nominal varistor voltage
100V	240V
200V	470V

Attachment position: between the relay control output contacts.

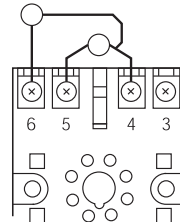

Operation

- The alarm function does not work properly when an error takes place unless the settings are made correctly. Always verify its setting before operation.
- If the input wiring breaks, the display will read “UUUU” or “LLLL”. When replacing the sensor, always turn the power OFF.

Others

- Please do not wipe the equipment with organic solvents such as alcohol or benzene, etc. If wiping is necessary, use a neutral cleaning agent.
- Do not use mobile phones near this equipment (within 50 cm). Otherwise a malfunction may result.
- Trouble may occur if the equipment is used near a radio, TV, or wireless device.
- This equipment should be treated as an industrial waste when it is disposed of.

Contents

Safety Instructions	1
⚠ WARNING.....	2
Installation and wiring	2
Maintenance	3
⚠ Caution	4
Installation.....	4
Panel mounting	4
Wiring.....	5
Operation	5
Others	5
For Proper Use	8
Model Specifications.....	9
1 Part names and functions.....	10
1-1 Operation keys.....	10
1-2 Indicators	11
1-3 Digital characters	12
2 Basic Operation	13
2-1 Basic operation	13
2-2 Changing SV (Set value)	14
2-3 Parameters List.....	15
Operation Mode	15
1st block parameter	15
2nd block parameter	16
3rd block parameter.....	18
2-4 Temperature control functions	19
2-5 Communication function	19
3 Parameter functions and setting procedure.....	20
3-1 1st block parameter	20
[MANU] Manual mode selection (001)	20
[Stby] Standby setting (002).....	21
[PRoG] Ramp soak control (004).....	22
[LACH] Alarm latch cancel (005).....	24
[At] Auto-tuning (006).....	25
[tM1] [tM2] Timer 1 display (007), Timer 2 display (008).....	27
[AL1] [A1-L] [A1-H] Alarm 1 settings (010, 011, 012).....	28
[AL2] [A2-L] [A2-H] Alarm 2 settings (013, 014, 015).....	28
[LoC] Key lock (019)	29

3-2	2nd block parameter	30
	[P] Proportional band (030)	30
	[i] Integral time (031)	30
	[d] Derivative time (032)	30
	[HyS] Hysteresis range for ON/OFF control (033).....	32
	[bAL] Output convergence value (036)	34
	[AR] Anti-reset windup (037).....	35
	[CtRL] Control algorithm (038).....	36
	[SLFb] PV (Process variable) stable range (039)	39
	[oNoF] Hysteresis mode (040).....	40
	[tC] Cycle time of control output 1 (041).....	41
	[P-N2] Input signal code (043)	42
	[P-SL] Lower limit of measuring range (044).....	43
	[P-SU] Upper limit of measuring range (045).....	43
	[P-dP] Decimal point position (046).....	45
	[PVOF] PV offset (048)	46
	[SVOF] SV shift (049).....	47
	[P-dF] Time constant of input filter (050).....	48
	[ALM1] [ALM2] Alarm type 1, 2 (051, 052)	49
	[StAt] Status display of ramp soak (054)	51
	[PtN] Ramp soak execution pattern (055)	52
	[SV-1] to [SV-8] 1st target SV to 8th target SV (056 to 077).....	53
	[tM1R] to [tM8R] 1st ramp time to 8th ramp time (057 to 078)	53
	[tM1S] to [tM8S] 1st soak time to 8th soak time (058 to 079).....	53
	[Mod] Ramp soak mode (080).....	55
3-3	3rd block parameter	57
	[P-N1] Control action (090)	57
	[SV-L] SV (Set value) lower limiter (091)	58
	[SV-H] SV (Set value) upper limiter (092).....	58
	[dLY1] [dLY2] Delay time 1, 2 (093, 094).....	59
	[A1Hy] [A2Hy] Alarm 1, 2 hysteresis (098, 099)	59
	[A1oP] [A2oP] Alarm 1, 2 options (101, 102)	61
	[PLC1] [PHC1] OUT1 Upper/Lower Limits (104, 105)	62
	[PCUt] Output limit types (108).....	63
	[oUt1] Output value (MV) display (109)	64
	[RCJ] RCJ (Cold junction compensation) setting (111)	65
	[AdJ0] User-definable zero adjustment (113)	66
	[AdJS] User-definable span adjustment (114).....	66
	[dSP1] to [dP14] Parameter mask (126 to 139).....	68
	[UKy1] [UKy2] [UKy3] USER key assignment (143, 144, 145).....	70
	[FLo1] MV1 during FALT (146).....	71
	[dSPt] PV/SV display OFF (148).....	72
4	Troubleshooting	73

For Proper Use

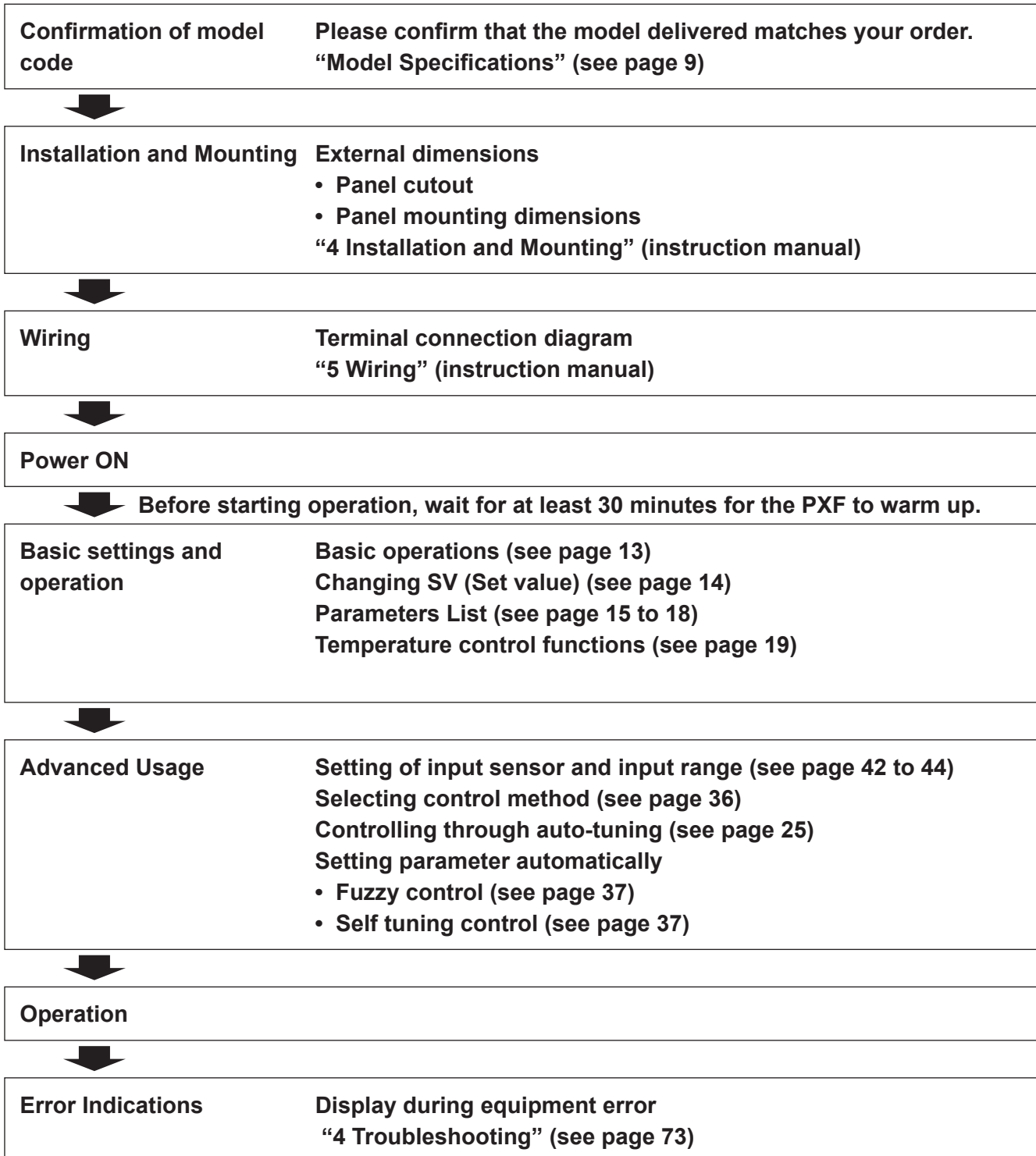

Model Specifications

Digit	Specifications	Note	4	5	6	7	8	9	10	11	12	13	
			PXF	4			U	2	-		Y	0	0
4	<Front panel size W × H> 48×48mm		↓										
5	<Input signal> Universal input (Thermocouple/Volt, backwards compatible wiring) Universal input (RTD/mA, backwards compatible wiring)	Note1		↓									
6	<Control output> Relay contact (SPDT) SSR drive output Current output				↓								
7	<Terminal form> Socket type					↓							
8	<Revision code>						↓						
9	<Alarm output> None 2 points							↓					
10	<Power supply voltage> 100 to 240V AC 24 V AC/DC								↓				
11										↓			
12											↓		
13												↓	

Note1: Wiring compatible to previous PXZ, PXW, PXV and PXR socket controllers.
(mA input dose not require the resistor)

1 Part names and functions

This section describes the names and functions of each part of the front panel. The front panel has the PV and SV displays, the status indicator lamps, and the setting keys, etc. Their functions are explained below. Please read and understand them before using the PXF.

For details about the setting of parameters, see Chapter 2 and Chapter 3.

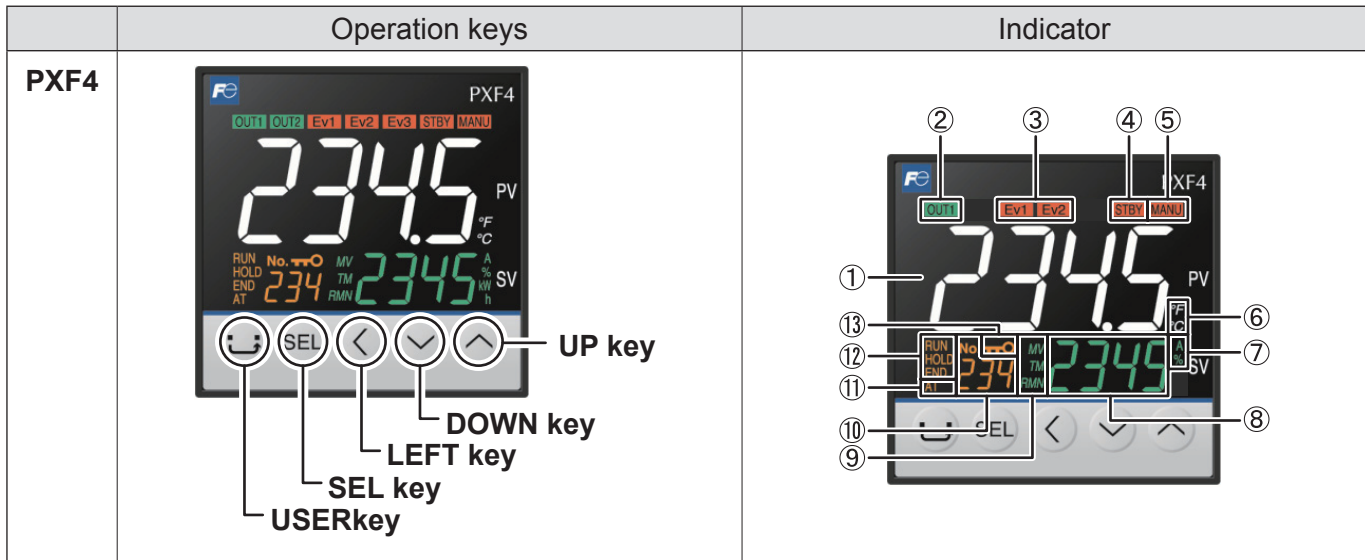

1-1 Operation keys

• USER key

- Press to switch between SV and MV during the PV/SV display (operation mode).
- Press to return to the operation mode from the parameter setup mode.
- Press and hold the USER key to start the assigned function during the PV/SV display (operation mode). (No function is allocated at the factory.)

• SEL key

- Press to enter the parameter setup mode from the operation mode or standby.
- Press to finish selecting and save change.

• LEFT key

- Press to move the digit when you editing the numerals.

• UP/DOWN key

- Press to change the SV during the PV/SV display.
- Press to switch the parameters during the parameter selection mode.
- Press to change the parameter value during the parameter editing mode.

• USER+UP keys, USER+DOWN keys

- By pressing and holding the USER key and the UP/DOWN key during the PV/SV display, you can start the assigned function.

In the factory default setting, the USER + UP key allows you to switch between run/standby, and the USER + DOWN key to switch between start/stop of auto-tuning.

See page 70 for how to change the setting of these keys.

1-2 Indicators

- (1) **Process variable (PV)**
Indicates the process variable. In the parameter setup mode, the parameter name is displayed.
- (2) **OUT1 indicator**
Lights during control output is ON.
- (3) **EV1, EV2 indicators**
Lights during digital output 1 to 2 are ON.
- (4) **STBY indicator**
Lights when the stanby is set to ON. (see page 21)
- (5) **MANU indicator**
Lights during manual mode. (see page 20)
- (6) **°C/°F indicator**
Shows the temperature unit under use.
- (7) **A, % indicator**
Indicates the unit applied to the value on SV screen during the parameter selection mode and parameter editing mode.
- (8) **Set Value (SV) / Manipulated variable (MV)**
Shows the setpoint or the manipulated variable. During the parameter editing mode, the parameter setpoint is displayed.
- (9) **MV indicator**
Lights when the MV is displayed.
- (10) **Screen No.**
Shows screen No. when in parameter setting.
- (11) **AT indicator**
Lights during auto tuning. (see page 25)
- (12) **RUN/HOLD/END indicators**
Lights during ramp soak operation. (see page 22)
- (13) **KEYLOCK indicator**
Lights when the keylock is on. (see page 29)

1-3 Digital characters

The following tables provide correspondence between digital characters used for the display of the controller and alphanumerical characters. (See the following table for details.)

Digital character	Alphabet
A	A
b	B
C	C
d	D
E	E
F	F
G	G
H	H
I	I
J	J
K	K
L	L
M	M
N	N
O	O
P	P
Q	Q
R	R
S	S
T	T
U	U
V	V
W	W
X	X
Y	Y
Z	Z

Digital character	Numer
1	1
2	2
3	3
4	4
5	5
6	6
7	7
8	8
9	9
0	0

2 Basic Operation

2-1 Basic operation

The below figure illustrates the mode transition and the key operations.

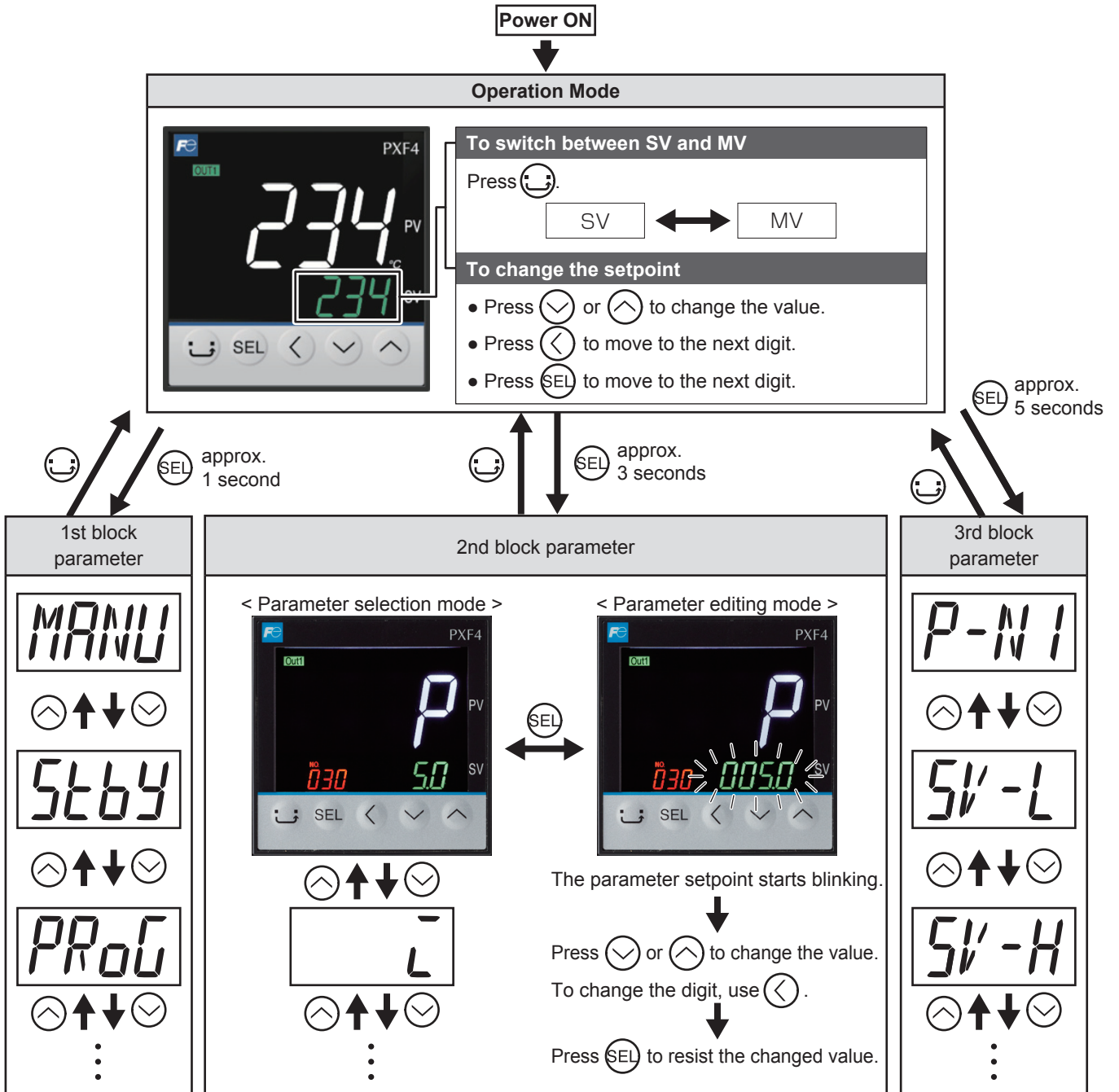

2-2 Changing SV (Set value)

[Description]

The SV is a target value for control.

- SV must be within the range between [SV-L] (lower limit) and [SV-H] (upper limit) which belong to Pid parameter.

Related parameters:

- **SV (Set value) lower limiter [SV-L], SV (Set value) upper limiter [SV-H] (see page 58)**

[Setting example] Changing the SV from 250°C to 1195°C

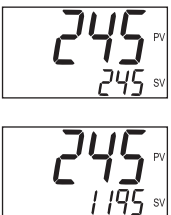
Display	Operating procedure
	<ol style="list-style-type: none"> 1. Check that the PV/SV display is shown. 2. Press ◀, ▼ or ▲ keys to change SV to “1195”. →The change become effective immediately.

2-3 Parameters List

The following explains each channel parameter.

- The range of the parameters in the shaded area indicates the industrial values.
When you change the PV input lower limit (P-SL), PV input upper limit (P-SU), or decimal place position (P-dP), reconfigure all the industrial values.
- Power-cycle the controller after you change the setpoint of the parameters of which No. column is shaded in gray.

Operation Mode

Parameter symbol	Parameter name	Setting range	Factory default setting	Parameter mask DSP
PV	Process Value	—	—	—
SV	Set value	Within the limit of 0 to 100% of FS	0 (°C)	—
MV	Manipulated Variable (%)	-5.0 to 105.0 (%)	-5.0	DSP14-32768

1st block parameter

No	Display	Parameter symbol	Parameter name	Setting range	Factory default setting	Parameter mask DSP	Reference page
1	MANU	MANU	Manual mode selection	oFF, oN	oFF	DSP13-32	20
2	Stby	Stby	Standby setting	oFF, oN	oFF	DSP1-1	21
4	PRoG	PRoG	Ramp soak control	oFF, RUN, HLd	oFF	DSP1-2	22
5	LACH	LACH	Alarm latch cancel	oFF, RSt	oFF	DSP1-4	24
6	At	At	Auto-tuning	oFF, oN, L-oN	oFF	DSP1-8	25
7	tM1	tM-1	Timer 1 display	—	—	DSP1-16	27
8	tM2	tM-2	Timer 2 display	—	—	DSP1-32	
10	AL1	AL1	Set value of alarm 1	Absolute value alarm: 0 to 100%FS Deviation alarm: -100 to 100%FS	10 (°C)	DSP1-128	28
11	A1-L	A1-L	Lower limit value of alarm 1	Absolute value alarm: 0 to 100%FS, Deviation alarm: -100 to 100%FS	10 (°C)	DSP2-1	
12	A1-H	A1-H	Upper limit value of alarm 1	Absolute value alarm: 0 to 100%FS Deviation alarm: -100 to 100%FS	10 (°C)	DSP2-2	
13	AL2	AL2	Set value of alarm 2	Absolute value alarm: 0 to 100%FS Deviation alarm: -100 to 100%FS	10 (°C)	DSP2-4	
14	A2-L	A2-L	Lower limit value of alarm 2	Absolute value alarm: 0 to 100%FS Deviation alarm: -100 to 100%FS	10 (°C)	DSP2-8	
15	A2-H	A2-H	Upper limit value of alarm 2	Absolute value alarm: 0 to 100%FS Deviation alarm: -100 to 100%FS	10 (°C)	DSP2-16	
19	LoC	LoC	Key lock	0 to 5	0	DSP3-1	29

Basic Operation

2nd block parameter

No	Display	Parameter symbol	Parameter name	Setting range	Factory default setting	Parameter mask DSP	Reference page
30	<i>P</i>	P	Proportional band	0.0 to 999.0 (%)	5.0	DSP3-2	30
31	<i>I</i>	i	Integral time	0 to 3200 (sec)	240	DSP3-4	
32	<i>d</i>	d	Derivative time	0.0 to 999.9 (sec)	60.0	DSP3-8	
33	<i>HYS</i>	HyS	Hysteresis range for ON/OFF control	0 to 50%FS	1 (°C)	DSP3-16	32
36	<i>bAL</i>	bAL	Output convergence value	-100.0 to 100.0 (%)	0.0	DSP3-128	34
37	<i>AR</i>	AR	Anti-reset windup	0 to 100%FS	400 (°C)	DSP4-1	35
38	<i>CTRL</i>	CtRL	Control algorithm	oNoF, Pid, FUZY, SELF, Pid2	Pid	DSP4-2	36
39	<i>SLFb</i>	SLFb	PV (Process variable) stable range	0 to 100%FS	8 (°C)	DSP4-4	39
40	<i>oNoF</i>	oNoF	Hysteresis mode	oN, oFF	oN	DSP4-8	40
41	<i>tC</i>	tC	Cycle time of control output 1	1 to 150 (sec)	Relay: 30	DSP4-16	41
					SSR: 2		
					Current: 1		
43	<i>P-N2</i>	P-N2	Input signal code	JPt (Resistance bulb (RTD) JPt100) Pt (Resistance bulb (RTD) Pt100) J (Thermocouple J) K (Thermocouple K) R (Thermocouple R) b (Thermocouple B) S (Thermocouple S) t (Thermocouple T) E (Thermocouple E) L (Thermocouple L) N (Thermocouple N) PL-2 (Thermocouple PL-II) W (Thermocouple W) 0-5V (DC voltage 0 to 5V DC) 1-5V (DC voltage 1 to 5V DC) 0-10 (DC voltage 0 to 10V DC) 2-10 (DC voltage 2 to 10V DC) 0-20 (Direct current 0 to 20mA) 4-20 (Direct current 4 to 20mA) U (Thermocouple U) MV (MV)	K	DSP4-64	42
44	<i>P-SL</i>	P-SL	Lower limit of measuring range	-1999 to 9999	0 (°C)	DSP4-128	43
45	<i>P-SU</i>	P-SU	Upper limit of measuring range	-1999 to 9999	400 (°C)	DSP5-1	
46	<i>P-dP</i>	P-dP	Decimal point position	0 to 3	0	DSP5-2	45
48	<i>PV_{oF}</i>	PVOF	PV offset	-10.00 to 10.00%FS	0 (°C)	DSP5-8	46
49	<i>SV_{oF}</i>	SVOF	SV shift	-50.00 to 50.00%FS	0 (°C)	DSP5-16	47
50	<i>P-dF</i>	P-dF	Time constant of input filter	0.0 to 120.0 (sec)	5.0	DSP5-32	48
51	<i>ALM1</i>	ALM1	Alarm type 1	0 to 31	0	DSP5-64	49
52	<i>ALM2</i>	ALM2	Alarm type 2	0 to 31	0	DSP5-128	
54	<i>StAt</i>	StAt	Status display of ramp soak	—	—	DSP6-2	51
55	<i>PtN</i>	PtN	Ramp soak execution pattern	1 to 3	1	DSP6-4	52

No	Display	Parameter symbol	Parameter name	Setting range	Factory default setting	Parameter mask DSP	Reference page
56	SV-1	SV-1	1st target SV	SV lower limit (SV-L) to SV upper limit (SV-H) %FS	0 (°C)	DSP6-8	53
57	tM1R	tM1R	1st ramp time	0.00 to 99.59	0:00	DSP6-16	
58	tM1S	tM1S	1st soak time	0.00 to 99.59	0:00	DSP6-32	
59	SV-2	SV-2	2nd target SV	SV lower limit (SV-L) to SV upper limit (SV-H) %FS	0 (°C)	DSP6-64	
60	tM2R	tM2R	2nd ramp time	0.00 to 99.59	0:00	DSP6-128	
61	tM2S	tM2S	2nd soak time	0.00 to 99.59	0:00	DSP7-1	
62	SV-3	SV-3	3rd target SV	SV lower limit (SV-L) to SV upper limit (SV-H) %FS	0 (°C)	DSP7-2	
63	tM3R	tM3R	3rd ramp time	0.00 to 99.59	0:00	DSP7-4	
64	tM3S	tM3S	3rd soak time	0.00 to 99.59	0:00	DSP7-8	
65	SV-4	SV-4	4th target SV	SV lower limit (SV-L) to SV upper limit (SV-H) %FS	0 (°C)	DSP7-16	
66	tM4R	tM4R	4th ramp time	0.00 to 99.59	0:00	DSP7-32	
67	tM4S	tM4S	4th soak time	0.00 to 99.59	0:00	DSP7-64	
68	SV-5	SV-5	5th target SV	SV lower limit (SV-L) to SV upper limit (SV-H) %FS	0 (°C)	DSP7-128	
69	tM5R	tM5R	5th ramp time	0.00 to 99.59	0:00	DSP8-1	
70	tM5S	tM5S	5th soak time	0.00 to 99.59	0:00	DSP8-2	
71	SV-6	SV-6	6th target SV	SV lower limit (SV-L) to SV upper limit (SV-H) %FS	0 (°C)	DSP8-4	
72	tM6R	tM6R	6th ramp time	0.00 to 99.59	0:00	DSP8-8	
73	tM6S	tM6S	6th soak time	0.00 to 99.59	0:00	DSP8-16	
74	SV-7	SV-7	7th target SV	SV lower limit (SV-L) to SV upper limit (SV-H) %FS	0 (°C)	DSP8-32	
75	tM7R	tM7R	7th ramp time	0.00 to 99.59	0:00	DSP8-64	
76	tM7S	tM7S	7th soak time	0.00 to 99.59	0:00	DSP8-128	
77	SV-8	SV-8	8th target SV	SV lower limit (SV-L) to SV upper limit (SV-H) %FS	0 (°C)	DSP9-1	
78	tM8R	tM8R	8th ramp time	0.00 to 99.59	0:00	DSP9-2	
79	tM8S	tM8S	8th soak time	0.00 to 99.59	0:00	DSP9-4	
80	Mod	Mod	Ramp soak mode	0 to 15	0	DSP9-8	55

Basic Operation

3rd block parameter

No	Display	Parameter symbol	Parameter name	Setting range	Factory default setting	Parameter mask DSP	Reference page
90	<i>P-N1</i>	P-N1	Control action	0 to 3	0	DSP9-16	57
91	<i>SV-L</i>	SV-L	SV (Set value) lower limiter	0 to 100%FS	0 (°C)	DSP9-32	58
92	<i>SV-H</i>	SV-H	SV (Set value) upper limiter	0 to 100%FS	400 (°C)	DSP9-64	
93	<i>dLY1</i>	dLY1	Delay time 1	0 to 9999 (sec)	0	DSP9-128	59
94	<i>dLY2</i>	dLY2	Delay time 2	0 to 9999 (sec)	0	DSP10-1	
98	<i>A1Hy</i>	A1Hy	Alarm 1 hysteresis	0 to 50%FS	1 (°C)	DSP10-16	59
99	<i>A2Hy</i>	A2Hy	Alarm 2 hysteresis	0 to 50%FS	1 (°C)	DSP10-32	
101	<i>A1oP</i>	A1oP	Alarm 1 options	000 to 111	000	DSP10-128	61
102	<i>A2oP</i>	A2oP	Alarm 2 options	000 to 111	000	DSP11-1	
104	<i>PLC1</i>	PLC1	Lower limit for output 1	-5.0 to 105.0 (%)	-5.0	DSP11-4	62
105	<i>PHC1</i>	PHC1	Upper limit for output 1	-5.0 to 105.0 (%)	105.0	DSP11-8	
108	<i>PCUt</i>	PCUt	Output limit types	0 to 3	0	DSP11-64	63
109	<i>oUt1</i>	oUt1	Output value (MV) display	—	—	DSP11-128	64
111	<i>RCJ</i>	RCJ	RCJ (Cold junction compensation) setting	oN, oFF	oN	DSP12-2	65
112	<i>GAIN</i>	GAIN	PV gradient	0.001 to 2.000	1.000	DSP12-4	—
113	<i>AdJ0</i>	AdJ0	User-definable zero adjustment	-50 to 50%FS	0 (°C)	DSP12-8	66
114	<i>AdJ5</i>	AdJS	User-definable span adjustment	-50 to 50%FS	0 (°C)	DSP12-16	
126	<i>dSP1</i>	dSP1	Parameter mask	—	Depends on the model	DSP14-128	68
127	<i>dSP2</i>	dSP2					
	:						
138	<i>dP13</i>	dP13					
139	<i>dP14</i>	dP14					
143	<i>UKy1</i>	UKy1	USER key	0 to 6	0	DSP14-8	70
144	<i>UKy2</i>	UKy2	USER key + UP key	0 to 6	1	DSP14-16	
145	<i>UKy3</i>	UKy3	USER key + DOWN key	0 to 6	5	DSP14-32	
146	<i>FLo1</i>	FLo1	MV1 during FALT	-5.0 to 105.0 (%)	-5.0	DSP14-64	71
148	<i>dSPt</i>	dSPt	PV/SV display OFF	0 to 8	0	DSP14-256	72

2-4 Temperature control functions

This controller has five types of temperature control function. Select according to type and use.

Temperature control functions	Description
ON/OFF (2-position) control	Switches output control ON/OFF according to the SV/PV magnitude relationship. Control systems can be built from simple elements such as SSR. This is appropriate for situations where high accuracy is not required.
PID control	PID calculation and controls proceed according to the previously set PID parameters. PID parameters can be set manually or through auto-tuning ([AT]). It is the most basic control in this equipment.
Fuzzy control	Reduces the amount of overshoot during control. It is effective when you want to suppress overshoot while changing SV, even during processes where it may take a long time to reach the target value.
Self tuning control	Adds controls while automatically calculating PID to meet the control target or changing SV. It is effective when the control conditions change frequently.
PID2 control	Suppresses the amount of overshoot during control for processes that turn the control target off and then on again. It is effective when the control target turns on and off while power flows continuously to the temperature controller.

You can set the temperature control function in the parameter [CTRL] (see page 36).

2-5 Communication function

This controller has the interface for the dedicated cable which allows data transmission with a PC.

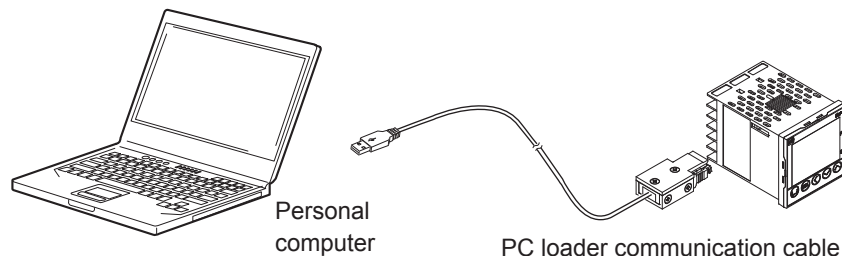

3 Parameter functions and setting procedure

3-1 1st block parameter

MANU Manual mode selection (001)

[Description]





Allows you to select how to set the manipulated variable, automatically or manually.

Setpoint	Description
oFF	Automatically
oN	Manually

- MANU indicator lights during manual operation. (see page 11)
- In this screen, only the switchover between auto/manual is available. Manual operation of control output is available on PV/MV screen.

Note This parameter is not displayed in default setting. To use this parameter, change the setting of the parameter “Parameter mask” (see page 68).

[Setting example] Changing the mode from Auto to Manual

Display	Operating procedure
	<p>1. Press and hold the SEL key for about one second during the SV/PV display. → MANU appears.</p>
	<p>2. Press the SEL key. → The setpoint starts blinking.</p>
	<p>3. Press the ↓ or ↑ keys to change “oFF” to “oN.”</p>
	<p>4. Press the SEL key or wait for three seconds to save the change.</p> <p>5. Press the ESC key. → The screen returns to the SV/PV display.</p>





Stby Standby setting (002)**[Description]**

Allows you to switch between run and standby.

Setpoint	Description
oFF	Operation mode
oN	Standby mode

- STBY indicator lights during stanby. (see page 11)
- When hold alarms is on, the hold function activates when you switch the standby setting from “oN” to “oFF.”
- If the instrument is put into standby during auto tuning, the auto tuning is canceled. To complete auto-tuning, turn standby setting “oFF” and restart auto tuning.
- When the controller switches to standby mode, the ON delay timer will be reset. It will begin again when standby setting is turned off.

[Setting example] Switching to Standby mode

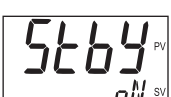
Display	Operating procedure
	1. Press and hold the SEL key for about one second during the SV/PV display. → MANU appears.
	
	2. Press the ▽ key to display 5t64 .
	3. Press the SEL key. → The setpoint starts blinking.
	4. Press the ▽ or △ keys to change “oFF” to “oN.”
	5. Press the SEL key or wait for three seconds to save the change. → Now the controller is in the standby mode.
	6. Press the ☺ key. → The screen returns to the SV/PV display.

Parameter functions and setting procedure

PRoG Ramp soak control (004)

[Description]

Allows you to switch between Ramp soak states.

Setpoint	Description
oFF	Ramp soak is stopped.
RUN	Ramp soak starts.
HLd	Ramp soak hold. To release the hold, select “RUN” again.

- This function automatically changes the SV (Set value) according to the program pattern set in advance as shown in the following line graph. Up to eight pairs of rampsoak operation can be programmed.

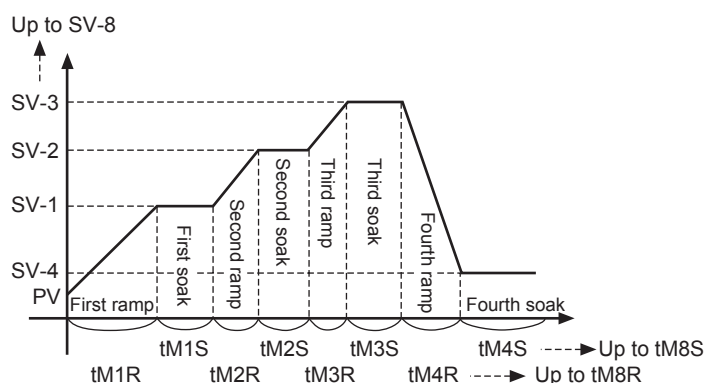

Ramp: the section in which the SV changes toward the target value.













Soak : the section in which the SV is the target value, and remains unchanged.

- The first ramp starts at the PV that is the one just before running the program.
- By setting the Ramp soak mode parameter [Mod] to “power-on start,” you can make the controller start with the ramp soak program (Power-on starting function).
- The parameter information changes automatically depending on the ramp soak state.
 - “END” (end): Ramp soak has finished.
- During ramp soak operation, one of RUN, HOLD, or END indicators light according to the state of ramp soak. (see page 11)
- During ramp soak operation, on-going step No. and “r” (ramp) or “-” (soak) are displayed on the screen No. area of operation screen (PV/SV screen).
For example, “2r” appears during step 2 ramp, and “2-” during step 2 soak.

Related parameters:

- **Status display of ramp soak [StAt]** (see page 51)
- **Ramp soak execution pattern [PtN]** (see page 52)
- **1st target SV to 8th target SV [SV-1] to [SV-8]** (see page 53)
- **1st ramp time to 8th ramp time [tM1R] to [tM8R]** (see page 53)
- **1st soak time to 8th soak time [tM1S] to [tM8S]** (see page 53)
- **Ramp soak mode [Mod]** (see page 55)

[Setting example] Starting the ramp soak program

Display	Operating procedure
	<p>1. Press and hold the  key for about one second during the SV/PV display. → <i>MANU</i> appears.</p>
	
	<p>2. Press the  key to display <i>PRoG</i>.</p>
	<p>3. Press the  key. → The setpoint starts blinking.</p>
	<p>4. Press the  or  keys to change “off” to “RUN.”</p>
	<p>5. Press the  key or wait for three seconds to save the change. → The ramp soak program starts.</p>
	<p>6. Press the  key. → The screen returns to the SV/PV display.</p>

Parameter functions and setting procedure





LACH Alarm latch cancel (005)

[Description]

Allows you to cancel the alarm latch.

Setpoint	Description
oFF	keeps the latch on
RSt	releases latch

[Setting example] Unlatching the alarm

Display	Operating procedure
	<p>1. Press and hold the SEL key for about one second during the SV/PV display. → <i>MANU</i> appears.</p>
	
	<p>2. Press the ▽ key to display <i>LACH</i>.</p>
	<p>3. Press the SEL key. → The setpoint starts blinking.</p>
	<p>4. Press the ▽ or △ keys to change “oFF” to “RSt.”</p>
	<p>5. Press the SEL key or wait for three seconds to save the change. → The alarm is unlatched.</p>
	<p>6. Press the ↵ key. → The screen returns to the SV/PV display.</p>

At Auto-tuning (006)**[Description]**

Running auto-tuning automatically sets the optimal PID.

Setpoint	Description
oFF	Stops or finishes the auto-tuning.
oN	Starts the normal auto-tuning.
L-oN	Starts the low-PV auto-tuning.

- There are the following two types in auto-tuning.

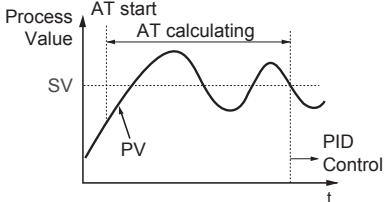
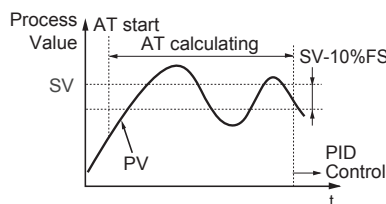







<p>Normal type Performs ON/OFF operation with SV as the baseline to calculate PID.</p>	
<p>Low-PV type Performs ON/OFF operation with SV-10% to calculate PID. Use this setting if you want to prevent overshoot.</p>	

- AT indicator lights during auto-tuning. (see page 11)
- When auto tuning is normally completed, the automatically set PID parameter value is maintained even if the power is turned off. If the power is turned off during auto tuning, the auto-tuning function is invalidated with PID parameters unchanged. In such a case, start again from the beginning.
- Since ON-OFF operation (2-position operation) is performed during auto tuning, PV may fluctuate greatly depending on the process. Do not perform auto tuning for the processes where large fluctuation of PV is not allowed. Do not perform auto tuning, either, for the processes where the response is quick, such as pressure control or flow rate control.
- If auto tuning does not end after 4 hours, it means that tuning may not be completed successfully. Check input/output wiring and parameters such as control output (forward, reverse) and input sensor type.
- Carry out the auto-tuning again when:
 - you change SV,
 - you change PV input type, or
 - operation does not work properly due to the change in operating conditions.
- You can run auto-tuning when the control type is set to “FUZY” or “Pid2.” (see page 36)
- You cannot run auto-tuning during manual mode. (see page 20)
- When you are using the PID selection function, the auto-tuning result for the selected PID group is stored.
- Auto tuning is forcibly terminated when SV is changed by the ramp soak function, remote SV function, or ramp SV.

Note

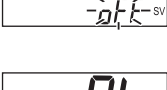
Since ON/OFF control is performed during auto-tuning, overshoot against the SV may occur. To reduce the overshoot, execute the auto-tuning with “L-oN” (Low PV).
Related parameters: [CtRL] (see page 36)

[Setting example] Running Auto-tuning

Display	Operating procedure
	<p>1. Press and hold the SEL key for about one second during the SV/PV display. → <i>MANU</i> appears.</p>
	
	<p>2. Press the ▽ key to display <i>AL</i>.</p>
	<p>3. Press the SEL key. → The setpoint starts blinking.</p>
	<p>4. Press the ▽ or △ keys to change “oFF” to “oN.”</p>
	
	<p>5. Press the SEL key or wait for three seconds to save the change. → The normal auto-tuning starts.</p>
	<p>6. Press the ☺ key. → The screen returns to the SV/PV display.</p>

tM1

tM2

Timer 1 display (007), Timer 2 display (008)**[Description]**









Displays the remaining time of the timer 1 and the timer 2.

- The remaining time of the ON/OFF-delay timer is counted down. When the counter shows “0,” the alarm relay is closed.
- During count-down, if the PV changes to the value of the temperature at which the alarm is set to OFF, the counter is reset, and the alarm relay is opened.

Related parameters:

- Alarm 1, 2 hysteresis [A1Hy], [A2Hy] (see page 59)
- Delay time 1, 2 [dLy1], [dLy2] (see page 59)

[Setting example] Checking the remaining time on the timer 1

Display	Operating procedure
	1. Press and hold the  key for about one second during the SV/PV display. → MANU appears.
	
	2. Press the  key to display tM1. → The remaining time on the timer 1 appears.
	3. Press the  key to display tM2. → The remaining time on the timer 2 appears.
	4. Press the  key. → The screen returns to the SV/PV display.

Parameter functions and setting procedure

AL1 **A1-L** **A1-H** Alarm 1 settings (010, 011, 012)

AL2 **A2-L** **A2-H** Alarm 2 settings (013, 014, 015)

[Description]

Allows you to set the alarm setpoint.

- AL1, AL2: Alarm
- A1-L, A2-L: Low-limit alarm
- A1-H, A2-H: High-limit alarm





Setting range
Absolute value alarm: 0 to 100%FS
Deviation alarm: -100 to 100%FS

- When the alarm type ([ALM1], [ALM2]) is set to 0 to 15, you can set the alarm 1, 2 ([AL1], [AL2]).
- When the alarm type ([ALM1], [ALM2]) is set to any value other than 0 to 15, you can set the upper and lower limits of alarm 1, 2 ([A1-H], [A2-H] and [A1-L], [A2-L]).

Related parameters:

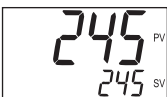
- Alarm type 1, 2 [ALM1], [ALM2] (see page 49)
- Alarm 1, 2 hysteresis [A1Hy], [A2Hy] (see page 59)
- Delay time 1, 2 [dLy1], [dLy2] (see page 59)
- Alarm 1, 2 options [A1oP], [A2oP] (see page 61)

[Setting example] Setting the alarm 1 to “20”

Display	Operating procedure
	<ol style="list-style-type: none"> 1. Press and hold the SEL key for about one second during the SV/PV display. → <i>MANU</i> appears. 2. Press the ▽ key to display <i>AL 1</i>. 3. Press the SEL key. → The setpoint starts blinking. 4. Press the ◀, ▽ or ▲ keys to change “10” to “20.” 5. Press the SEL key or wait for three seconds to save the change. 6. Press the ☺ key. → The screen returns to the SV/PV display.
	
	
	
	





LoC Key lock (019)**[Description]** _____

Prevents SV parameters from being changed.

Setpoint	Description
0	Unlocked (reset)
1	All settings are unchangeable from the controller, but changeable via communication.
2	Only the SV is changeable from the controller, and all settings are changeable via communication.
3	All settings are changeable from the controller, but unchangeable via communication.
4	All settings are unchangeable from the controller or via communication.
5	Only the SV is changeable from the controller, but all settings are unchangeable via communication.

- When the keylock is set to 1, 2, 4, or 5, the KEYLOCK indicator lights. (see page 11)
- You can view the parameters regardless of the keylock setting.

[Setting example] Changing the keylock setting to 2 _____

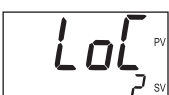
Display	Operating procedure
	1. Press and hold the SEL key for about one second during the SV/PV display. → <i>MANU</i> appears.
	
	2. Press the ▽ key to display <i>LoC</i> .
	3. Press the SEL key. → The setpoint starts blinking.
	4. Press the △ key to change “0” to “2.”
	5. Press the SEL key or wait for three seconds to save the change. → Keylock is activated.
	6. Press the ☺ key. → The screen returns to the SV/PV display.

3-2 2nd block parameter

P Proportional band (030)

i Integral time (031)

d Derivative time (032)

[Description]

Allows you to set PID (Proportional Band, Integration Time, Differential Time).

Setting range
P: 0.0 to 999.9%
i: 0 to 3200 seconds
d: 0.0 to 999.9 seconds

- The following control methods are available with PID settings.











ON/OFF control (2-position control)	When [P] = "0" or the control method [CtRL] is set to "oNoF," ON/OFF control is used. Use this function when you want to run simple control without worrying about the controllability.
PID control	Use this function when you want to control with high controllability. [P], [i], and [d] should be adjusted to optimal values for the control target, although Pid can be activated by setting the control method [CtRL] to "Pid," and [P] ≠ "0.0," [i] ≠ "0," [d] ≠ "0.0." In normal situations, run auto-tuning to optimally adjust P, I, and D before using this function.
PI control	When the control method [CtRL] is set to "Pid" and [P] ≠ "0.0," [i] ≠ "0," [d] = "0.0," D control is turned off and PI control is used.
P control	When the control method [CtRL] is set to "Pid" and [P] ≠ "0.0," [i] = "0," [d] = "0.0," I and D controls are turned off and P control is used. In principle, P control generates offset and PV does not agree with SV. In this case, adjust the output convergence value [bAL].

- Running auto-tuning automatically sets the optimal PID. (see page 25)
- The PID settings configured by auto-tuning are generally considered to be optimal settings. If you want to change the responsiveness, adjust PID manually.
- Generally, control becomes unstable when [P] is set too small. On the other hand, setting it too big makes the response slow.
- If you set [P] to "0.0," the control method parameter [CtRL] automatically turn to "oNoF."
- Set the hysteresis for the ON/OFF (2-position) control with the parameter [HyS]. (see page 32)

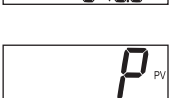
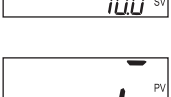
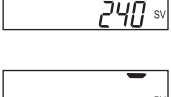
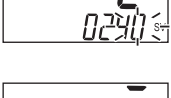
Related parameters: Control algorithm [CtRL] (see page 36)

Caution Do not perform auto tuning during ON/OFF control.

[Setting example] Setting P = 10.0%, I = 100sec, D = 20sec

Display	Operating procedure
	<p>1. Press and hold the SEL key for about three seconds during the SV/PV display. →P appears.</p>
	
	<p>2. Press the SEL key. →The setpoint starts blinking.</p>
	<p>3. Press the ◀, ▼ or ▲ keys to change “5.0” to “10.0.”</p>
	<p>4. Press the SEL key or wait for three seconds to save the change. →The setpoint is set to “10.0.”</p>
	<p>5. Press the ▼ key to display L.</p>
	<p>6. Press the SEL key. →The setpoint starts blinking.</p>
	<p>7. Press the ◀ or ▼ keys to change “240” to “100.”</p>
	<p>8. Press the SEL key or wait for three seconds to save the change. →The setpoint is set to “100.”</p>
	<p>9. Press the ▼ key to display d.</p>
	<p>10. Press the SEL key. →The setpoint starts blinking.</p>
	<p>11. Press the ◀ or ▼ keys to change “60.0” to “20.0.”</p>
	<p>12. Press the SEL key or wait for three seconds to save the change.</p>
	<p>13. Press the ☺ key. →The screen returns to the SV/PV display.</p>

Parameter functions and setting procedure

HyS Hysteresis range for ON/OFF control (033)

[Description]

If you set the control method parameter [CtRL] to “oNoF,” set the hysteresis for on/off control in this parameter.

Setting range

0 to 50%FS

- The controllability varies with the size of the hysteresis.

Small hysteresis	<ul style="list-style-type: none"> High-precision control Frequency of output relays is high, so lifespan becomes short.
Large hysteresis	<ul style="list-style-type: none"> Low-precision control Frequency of output relays is low, so lifespan is relatively long.



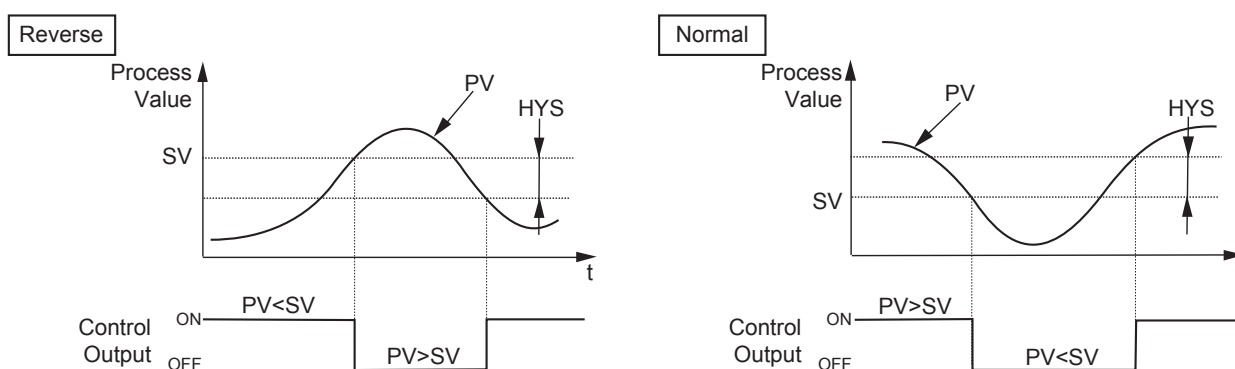

- The relationship between SV and hysteresis in normal and reverse operation is shown below.

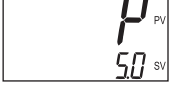

- During ON/OFF control, the [i] and [d] settings do not affect control.
- If the hysteresis width is narrow, and PV and SV are nearly equal, the output may frequently switch on and off. Note that it may affect the life of the contact.

Related parameters: Control algorithm [CtRL] (see page 36)

[Setting example] Changing the hysteresis range from 25%FS to 30%FS _____

Display	Operating procedure
	<p>1. Press and hold the SEL key for about three seconds during the SV/PV display. →P appears.</p>
	
	<p>2. Press the ▽ key to display <i>HYS</i>.</p>
	<p>3. Press the SEL key. →The setpoint starts blinking.</p>
	<p>4. Press the ◀, ▽ or ▲ keys to change “25” to “30.”</p>
	<p>5. Press the SEL key or wait for three seconds to save the change.</p> <p>6. Press the ☺ key. →The screen returns to the SV/PV display.</p>

Parameter functions and setting procedure

bAL Output convergence value (036)

[Description]

Output convergence value is a function that adds an offset to MV value.

Setting range

-100 to 100%

- By this function, the [bAL] offset is added to original MV which is the result of PID calculation determined by PV and SV, and the total value is emitted as MV.

(The factory default setting is 0%.)

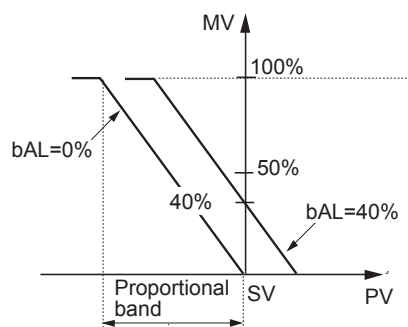

[Setting example] Changing Output convergence value from 0.0% to 3.0%

Display	Operating procedure
	<ol style="list-style-type: none"> Press and hold the SEL key for about three seconds during the SV/PV display. → <i>P</i> appears.
	<ol style="list-style-type: none"> Press the ▽ key to display <i>bAL</i>.
	<ol style="list-style-type: none"> Press the SEL key. → The setpoint starts blinking.
	<ol style="list-style-type: none"> Press the ◀, ▽ or ▲ keys to change “0.0” to “3.0.”
	<ol style="list-style-type: none"> Press the SEL key or wait for three seconds to save the change. Press the ☺ key. → The screen returns to the SV/PV display.

AR Anti-reset windup (037)**[Description]**

Anti-reset windup is a function that limits the range of valid integration to control overshooting.

Setting range**0 to 100%FS**

- The anti-reset windup function ([AR]) disables the integration when the PV falls outside of the Ar set range that is centered around SV. It is automatically set to the optimum value when auto-tuning is activated.

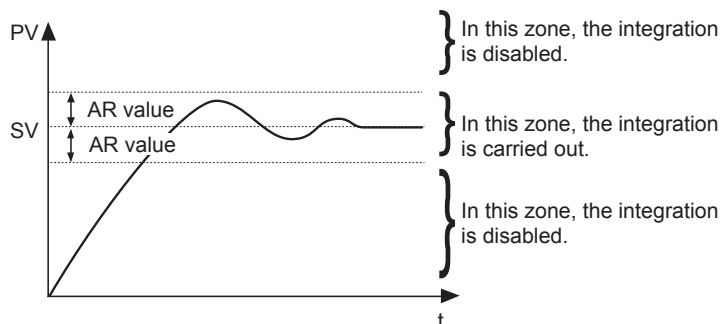
**[Setting example]** Changing the anti-reset windup to 500°C

Display	Operating procedure
	1. Press and hold the SEL key for about three seconds during the SV/PV display. → <i>P</i> appears.
	2. Press the ▽ key to display <i>AR</i> .
	3. Press the SEL key. → The setpoint starts blinking.
	4. Press the ◀ , ▽ or ▶ keys to change “100” to “500.”
	5. Press the SEL key or wait for three seconds to save the change.
	6. Press the ☺ key. → The screen returns to the SV/PV display.

CtRL Control algorithm (038)

[Description]

This controller has five temperature control functions. Select the best control method for your application.

Setpoint	Description
oNoF	ON/OFF (2-position) control
Pid	PID control
FUZY	Fuzzy control
SELF	Self tuning control
Pid2	PID2 control

(1) ON/OFF (2-position) control (oNoF)

When you set the control method [CtRL] to “oNoF,” the device uses ON/OFF control.

In ON/OFF control, the controller switches the control output between ON (100%) and OFF (0%) according to the SV/PV magnitude relationship. You can set the output hysteresis in the control parameters [HYS] (see page 32).

Reverse Operation (Heating)

Method used to control the electrical heating furnace. Set the [HYS] to an appropriate value according to the control target.

Parameter	Set value
CtRL	oNoF
P-N1	2 or 3
HyS	0 to 50% FS (default: 1°C)

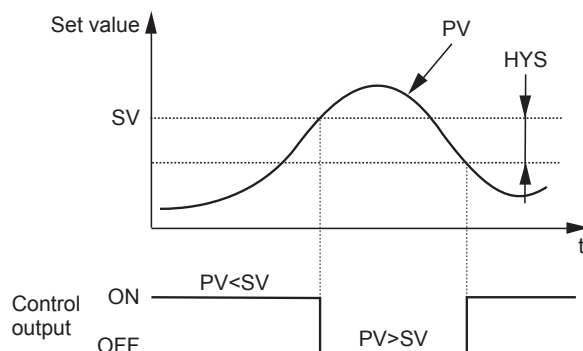

Normal operation (Cooling)

Method used to control the cooling machine.

Parameter	Set value
CtRL	oNoF
P-N1	0 or 1
HyS	0 to 50% FS (default: 1°C)

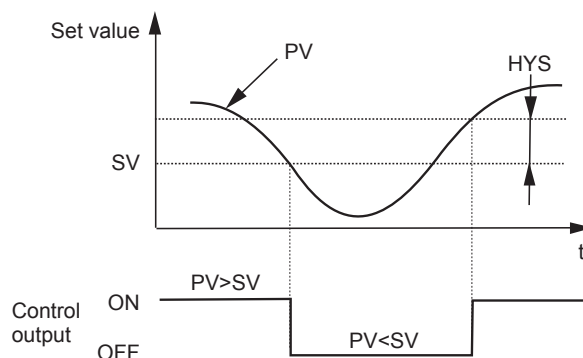

Notes

- During ON/OFF control, the P, I and D settings do not affect control.
- In the manual operation during ON/OFF control, MV displayed by pressing ⊖ key is 100%, and MV displayed by pressing ⊕ key is 0%.
- If the hysteresis width is narrow, and PV and SV are nearly equal, the output may frequently switch on and off. Note that it may affect the contact life.

Related parameters:

- Control action [P-N1] (see page 57)
- Hysteresis range for ON/OFF control [HyS] (see page 32)

(2) PID control (Pid)

PID control starts when the parameter [CtRL] is “Pid.” PID control calculate Pid and output the result according to the set values of the parameters [P], [i], [d], and [AR]. (-5 to 105%)

Each parameter can be set either by manually tuning the values or by running auto-tuning ([AT]) to automatically set the values.

Related parameters: Auto-tuning [At] (see page 25)

(3) Fuzzy control (FUZY)

This control minimizes the overshoot compared to normal PID. Fuzzy control can only be used after auto-tuning has been activated and a PID set.

Related parameters: Auto-tuning [At] (see page 25)

(4) Self tuning control (SELF)

Adds controls while automatically calculating PID to meet the control target or changing SV. Self-tuning is especially effective for situations when a high level of control is not needed, but auto-tuning cannot be run due to frequent changes in the control target conditions. If a high degree of control is required, select PID control, fuzzy control or PID2 control.

- The equipment will not be tuned properly if power is turned on first.
- When redoing the self-tuning settings, first set the control method to PID (“Pid”), and then set back to self-tuning.

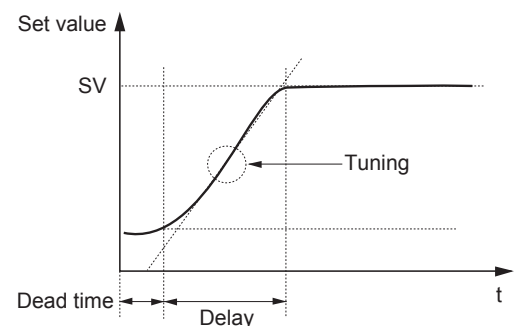

Conditions where self-tuning can be used

- When temperature rises right after the power is turned on
- When temperature rises after SV change (or when the controller judges it necessary)
- When the controller judges it necessary because the control has become unstable

Conditions where self-tuning cannot be used

- During standby
- During ON/OFF (2-position) control
- During auto-tuning
- During ramp soak operation
- When input error occurs
- When any of the [P], [i], [d], or [AR] parameters have been manually configured
- During manual mode
- During soft start

Conditions where self-tuning is halted

- When SV is changed (including when SV is changed by the ramp soak function, remote SV function, or ramp SV.)
- When self-tuning has not finished after running for nine or more hours

Parameter functions and setting procedure

(5) PID2 control (Pid2)

This type of control reduces overshoot during control for processes that turn the control target off and then on again.

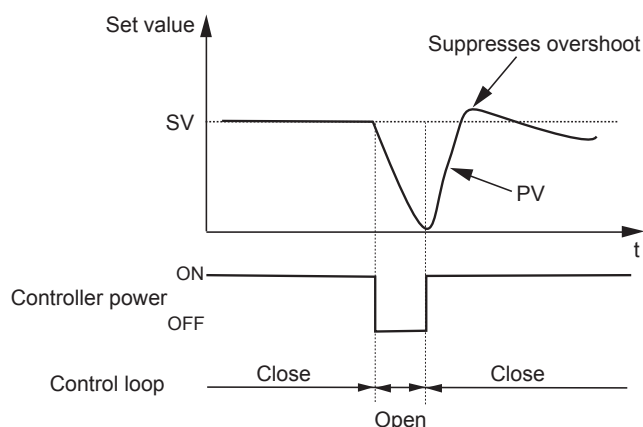

The algorithm used prevents over-integration of the PID calculations even while the control loop is still open. PID2 control can only be used after auto-tuning has been activated and a PID set.

[Setting example] Setting the control method to ON/OFF control

Display	Operating procedure
	1. Press and hold the SEL key for about three seconds during the SV/PV display. → P appears.
	2. Press the ▽ key to display CTRL .
	3. Press the SEL key. → The setpoint starts blinking.
	4. Press the ▽ or △ keys to change “Pid” to “oNoF.”
	5. Press the SEL key or wait for three seconds to save the change. → The control method is set to ON/OFF control.
	6. Press the ↩ key. → The screen returns to the SV/PV display.





SLFb PV (Process variable) stable range (039)**[Description]**

Self-tuning logic recognizes that control is stable if PV is staying within the $SV \pm [SLFb]$.

Setting range**0 to 100%FS**

- It is not necessary to set this parameter under normal conditions.

[Setting example] Changing the PV stable range from 2 to 3

Display	Operating procedure
	<ol style="list-style-type: none"> 1. Press and hold the SEL key for about three seconds during the SV/PV display. →P appears.
	
	<ol style="list-style-type: none"> 2. Press the ▽ key to display <i>SLFb</i>.
	<ol style="list-style-type: none"> 3. Press the SEL key. →The setpoint starts blinking.
	<ol style="list-style-type: none"> 4. Press the ◀, ▽ or ▲ keys to change “2.0” to “3.0.”
	<ol style="list-style-type: none"> 5. Press the SEL key or wait for three seconds to save the change.
	<ol style="list-style-type: none"> 6. Press the ☺ key. →The screen returns to the SV/PV display.

Parameter functions and setting procedure

oNoF Hysteresis mode (040)



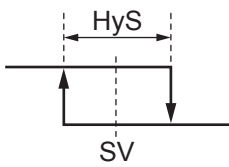
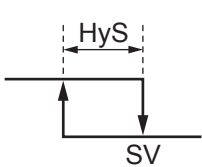
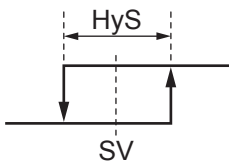
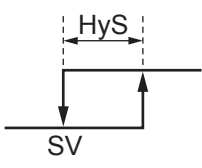

[Description]

Selects the hysteresis operation during two-position control.

Setpoint	Description
oFF	Performs two-position control with the range between $[SV+HyS/2]$ and $[SV-HyS/2]$.
oN	Performs two-position control with the range between $[SV, SV+HyS]$ and $[SV, SV-HyS]$.

	Setpoint: oFF	Setpoint: oN
Reverse		
Normal Operation		

[Setting example] Setting the hysteresis mode to OFF

Display	Operating procedure
	<ol style="list-style-type: none"> Press and hold the SEL key for about three seconds during the SV/PV display. → P appears. Press the ▽ key to display oNoF. Press the SEL key. → The setpoint starts blinking. Press the ▽ or △ keys to change “oN” to “oFF.” Press the SEL key or wait for three seconds to save the change. Press the ↵ key. → The screen returns to the SV/PV display.
	
	
	
	

tC Cycle time of control output 1 (041)**[Description]**

When using contact output and SSR drive output with PV input inside the proportional band, output will switch between ON and OFF at regular intervals.

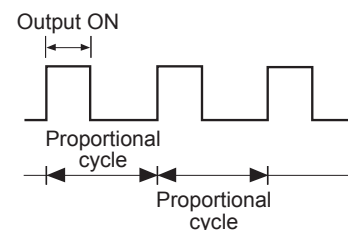
**Setting range****1 to 150 sec**

- The following are the recommended settings for each control output.

Contact output	The shorter the proportional cycle, the finer the control. However, shorter proportional cycles also shorten the lifespan of the contact points and operating device. Keep a balance between controllability and controller lifespan when adjusting the proportional cycles. Approx.: 30 sec
SSR drive output	Because there are no mechanical parts, use a short proportional cycle if the operating device is working properly. Approx.: 1 or 2 seconds

Note

- The proportional cycle for the current output is same as the blinking cycle of OUT indicator (approximately 1 second).

[Setting example] Setting OUT1 proportional cycle to 60 sec

Display	Operating procedure
	1. Press and hold the SEL key for about three seconds during the SV/PV display. →P appears.
	2. Press the ▽ key to display tC.
	3. Press the SEL key. →The setpoint starts blinking.
	4. Press the ▽ or △ keys to change “30” to “60.”
	5. Press the SEL key or wait for three seconds to save the change.
	6. Press the ↵ key. →The screen returns to the SV/PV display.

Parameter functions and setting procedure

P-N2 Input signal code (043)

[Description]



Allows you to select PV input source from thermocouples, RTD, and others.

Setpoint	Description	Setpoint	Description
JPt	RTD JPt100	N	Thermocouple N
Pt	RTD Pt100	PL-2	Thermocouple PL-II
J	Thermocouple J	W	Thermocouple W
K	Thermocouple K	0-5V	0 to 5 V DC
R	Thermocouple R	1-5V	1 to 5 V DC
b	Thermocouple B	0-10	0 to 10 V DC
S	Thermocouple S	2-10	2 to 10 V DC
t	Thermocouple T	0-20	0 to 20 mA DC
E	Thermocouple E	4-20	4 to 20 mA DC
L	Thermocouple L	U	Thermocouple U
		MV	MV

Note

- The connection to the terminal block differs with types of input (thermocouple/RTD/voltage or current input). Check the Instruction Manual.
- Power-cycle the controller after you change the input type setting.

[Setting example] Changing the input from thermocouple K to thermocouple R —

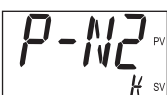
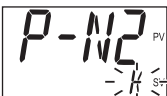
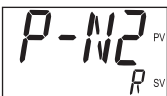
Display	Operating procedure
	<ol style="list-style-type: none"> 1. Press and hold the SEL key for about three seconds during the SV/PV display. → P appears.
	
	<ol style="list-style-type: none"> 2. Press the ▽ key to display P-N2
	<ol style="list-style-type: none"> 3. Press the SEL key. → The setpoint starts blinking.
	<ol style="list-style-type: none"> 4. Press the ▽ or △ keys to change “K” to “R.”
	<ol style="list-style-type: none"> 5. Press the SEL key or wait for three seconds to save the change.
	<ol style="list-style-type: none"> 6. Press the ☺ key. → The screen returns to the SV/PV display.

P-SL Lower limit of measuring range (044)**P-SU** Upper limit of measuring range (045)**[Description]**

Allows you to set the upper/lower limit of PV input within the measurement range.

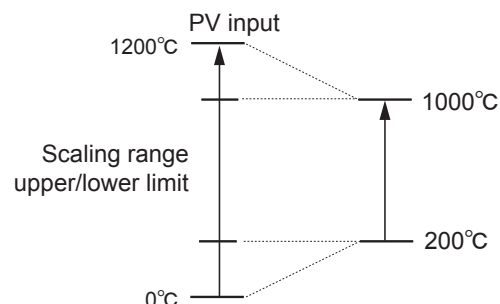
Setting range**-1999 to 9999****Note**







- Be sure to set the values so that [P-SU] is greater than [P-SL].
- Be sure to set the values so that the subtraction of [P-SL] from [P-SU] is less than 10000 with no decimal point.

• Measurement range

Input type	[P-N2] Setpoint	Measurement range	Minimum increment (°C)
RTD JPt100	JPt	0.0 to 150.0	0.1
		0.0 to 300.0	0.1
		0.0 to 500.0	0.1
		0.0 to 600.0	0.1
		-50.0 to 100.0	0.1
		-100.0 to 200.0	0.1
RTD Pt100	Pt	0.0 to 150.0	0.1
		0.0 to 300.0	0.1
		0.0 to 500.0	0.1
		0.0 to 600.0	0.1
		-50.0 to 100.0	0.1
		-100.0 to 200.0	0.1
Thermocouple J	J	0.0 to 400.0	0.1
		-20.0 to 400.0	0.1
		0.0 to 800.0	0.1
		-100 to 1000	1
Thermocouple K	K	0 to 400	0.1
		-20.0 to 500.0	0.1
		0.0 to 800.0	0.1
		-200 to 1300	1
Thermocouple R	R	0 to 1700	1
Thermocouple B	b	0 to 1800	1

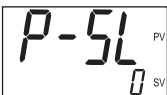
Input type	[P-N2] Setpoint	Measurement range	Minimum increment (°C)
Thermocouple S	S	0 to 1700	1
Thermocouple T	t	-199.9 to 200.0	0.1
		-199.9 to 400.0	0.1
Thermocouple E	E	0.0 to 800.0	0.1
		-150.0 to 800.0	0.1
		-200 to 800	1
Thermocouple L	L	-100 to 850	1
Thermocouple N	N	-200 to 1300	1
Thermocouple PL-II	PL-2	0 to 1300	1
Thermocouple W	W	0 to 2300	1
DC voltage DC0 to 5V	0-5V	-1999 to 9999 (Scaling is possible)	—
DC voltage DC1 to 5V	1-5V		
DC voltage DC0 to 10V	0-10		
DC voltage DC2 to 10V	2-10		
Direct current 0-20mA	0-20	-199.9 to 400.0	0.1
Direct current 4-20mA	4-20		
Thermocouple U	U	-199.9 to 400.0	0.1
		-200 to 400	1

[Setting example] Setting the PV input upper limit to 1000°C and lower limit to 200°C —

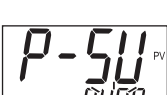
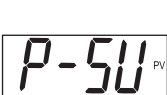
Display	Operating procedure
	<p>1. Press and hold the SEL key for about three seconds during the SV/PV display. → <i>P</i> appears.</p>
	
	<p>2. Press the ▽ key to display <i>P-5L</i>.</p>
	<p>3. Press the SEL key. → The setpoint starts blinking.</p>
	<p>4. Press the ◀ or ▶ keys to change “0” to “200.”</p>
	<p>5. Press the SEL key or wait for three seconds to save the change.</p>
	<p>6. Press the ▽ key to display <i>P-5U</i>.</p>
	<p>7. Press the SEL key. → The setpoint starts blinking.</p>
	<p>8. Press the ◀, ▽ or ▶ keys to change “400” to “1000.”</p>
	<p>9. Press the SEL key or wait for three seconds to save the change.</p>
	<p>10. Press the ☺ key. → The screen returns to the SV/PV display.</p>

P-dP Decimal point position (046)**[Description]**

Sets the decimal point position for the PV.

Setpoint	Description
0	No digit after decimal point
1	1 digit after decimal point
2	2 digits after decimal point
3	3 digits after decimal point

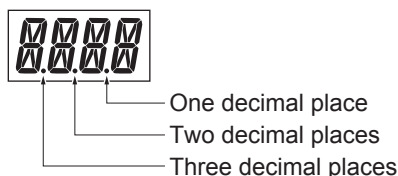

- Two decimal places and three decimal places are available only when the input is voltage or current.
- If you change the setting from numerals without decimal point to numerals with decimal point, the measurement range setting ([P-SL], [P-SU]) is limited to the range from -199.9°C through 999.9°C.
For example, if you make the above change when the range is from 0 through 1300°C, the range will become the one from 0.0 through 999.9°C.

[Setting example] Setting the PV display with one decimal place

Display	Operating procedure
	1. Press and hold the SEL key for about three seconds during the SV/PV display. → P appears.
	2. Press the ▽ key to display P-dP .
	3. Press the SEL key. → The setpoint starts blinking.
	4. Press the △ key to change “0” to “1.”
	5. Press the SEL key or wait for three seconds to save the change.
	6. Press the ↵ key. → The screen returns to the SV/PV display.

Parameter functions and setting procedure

PVOF PV offset (048)

[Description]

This function shifts PV input before display.

This function can be used to make the SV correspond with other instruments.

Setting range

-10.00 to 10.00%FS

- This controller operates at the displayed PV (the value to which the PV offset value is added).

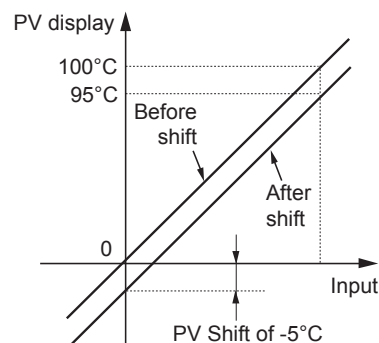

[Setting example] Setting the PV input shift to -5.0°C

Display	Operating procedure
	<ol style="list-style-type: none"> 1. Press and hold the SEL key for about three seconds during the SV/PV display. → P appears. 2. Press the ▽ key to display PV_{oF}. 3. Press the SEL key. → The setpoint starts blinking. 4. Press the ▽ key to change “0” to “-5.” 5. Press the SEL key or wait for three seconds to save the change. 6. Press the ↵ key. → The screen returns to the SV/PV display.

SVOF SV shift (049)**[Description]**





This function specifies the SV shift. This is used to eliminate remaining offset when using P control.

Setting range

-50.00 to 50.00%FS

- Controls act on the calculated SV with SV offset.
- Alarm determination acts on the displayed SV without SV offset.

[Setting example] Setting the SV shift to 7°C

Display	Operating procedure
	1. Press and hold the SEL key for about three seconds during the SV/PV display. →P appears.
	
	2. Press the ▽ key to display SV of.
	3. Press the SEL key. →The setpoint starts blinking.
	4. Press the ◀ or ▶ keys to change “0.0” to “7.0.”
	5. Press the SEL key or wait for three seconds to save the change.
	6. Press the ☺ key. →The screen returns to the SV/PV display.

Parameter functions and setting procedure

P-dF Time constant of input filter (050)

[Description]

This low-pass filter function reduces noise and signal fluctuation.

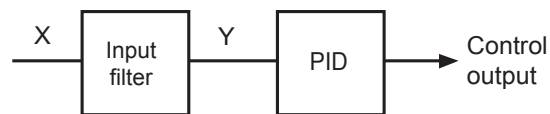

Setting range

0.0 to 120.0 sec

- If the input filter time constant is set to 5 and input is changed from 0 to 100%, the PV display gradually changes, and it takes about 5 seconds for the value to change from 0 to 63.2%, as shown in the right figure.

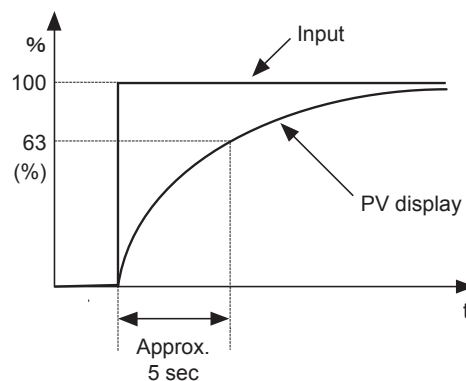

Note

The factory setting for input filter time constant is 5%.
Do not change this value unless absolutely necessary.

[Setting example] Setting the PV input filter time constant to 10 seconds

Display	Operating procedure
	1. Press and hold the SEL key for about three seconds during the SV/PV display. → <i>P</i> appears.
	2. Press the ▽ key to display <i>P-dF</i> .
	3. Press the SEL key. → The setpoint starts blinking.
	4. Press the ◀ , ▽ or ▲ keys to change “5.0” to “10.0.”
	5. Press the SEL key or wait for three seconds to save the change.
	6. Press the ☺ key. → The screen returns to the SV/PV display.

ALM1 **ALM2** Alarm type 1, 2 (051, 052)

[Description]

Set the alarm type for Alarm1, Alarm2.

1-point alarm

Type	Setpoint	Alarm type	Action diagram
	0	No alarm	—
Absolute value alarm	1	High alarm	
	2	Low alarm	
	3	High alarm (with hold)	
	4	Low alarm (with hold)	
Deviation alarm	5	High alarm	
	6	Low alarm	
	7	High/Low alarm	
	8	High alarm (with hold)	
	9	Low alarm (with hold)	
	10	High/Low alarm (with hold)	
Zone alarm	11	High/Low deviation alarm	

2-point alarm

Type	Setpoint	Alarm type	Action diagram	
High/Low limit alarm	16	High/Low absolute alarm		
	17	High/Low deviation alarm		
	18	High absolute/Low deviation alarm		
	19	High deviation/Low absolute alarm		
	20	High/Low absolute alarm (with hold)		
	21	High/Low deviation alarm (with hold)		
	22	High absolute/Low deviation alarm (with hold)		
	23	High deviation/Low absolute alarm (with hold)		
	Zone alarm	24	High/Low absolute alarm	
		25	High/Low deviation alarm	
26		High absolute/Low deviation alarm		
27		High deviation/Low absolute alarm		
28		High/Low absolute alarm (with hold)		
29		High/Low deviation alarm (with hold)		
30		High absolute/Low deviation alarm (with hold)		
31		High deviation/Low absolute alarm (with hold)		

- ALn: indicates the alarm set values (AL1 to AL2)
- An-H: indicates the alarm set values (A1-H to A2-H)
- An-L: indicates the alarm set values (A1-L to A2-L)

What is alarm with hold?

The alarm will not turn ON immediately when the process value gets into the alarm band and enters again.

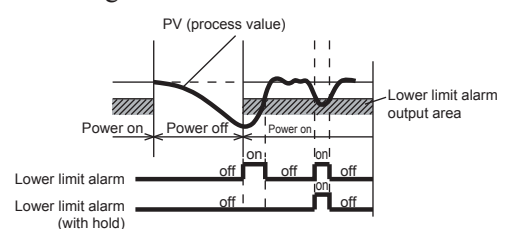













Note

- When alarm action code is changed, alarm set value may also become different from previous settings.
- Power-cycle the controller after you change the alarm type.

[Setting example]

Setting the type of the alarm 1 to “upper limit deviation alarm with hold” _____

Display	Operating procedure
	<p>1. Press and hold the  key for about three seconds during the SV/PV display. → P appears.</p>
	
	<p>2. Press the  key to display <i>ALM 1</i>.</p>
	<p>3. Press the  key. → The setpoint starts blinking.</p>
	<p>4. Press the ,  or  keys to change “0” to “8.”</p>
	<p>5. Press the  key or wait for three seconds to save the change.</p>
	<p>6. Press the  key. → The screen returns to the SV/PV display.</p>



StAt Status display of ramp soak (054)**[Description]**

Displays the progress of the ramp soak.

The ramp soak statuses are indicated as follows.

Display	Status
oFF	Ramp soak is stopped
1-RP	Step 1 ramp
1-St	Step 1 soak
2-RP	Step 2 ramp
2-St	Step 2 soak
⋮	⋮
8-RP	Step 8 ramp
8-St	Step 8 soak
ENd	Ramp soak is finished

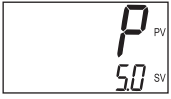
[Setting example] Checking ramp soak progress

Display	Operating procedure
	1. Press and hold the (SEL) key for about three seconds during the SV/PV display. → P appears.
	2. Press the (V) key to display START . → Ramp soak progress is displayed.
	3. Press the (M) key. → The screen returns to the SV/PV display.
	

Parameter functions and setting procedure

PtN Ramp soak execution pattern (055)

[Description]

The 8-step ramp soak patterns are divided into 3 segments. You can choose any one to use.

Setpoint	Description
1	Steps 1 to 4
2	Steps 5 to 8
3	Steps 1 to 8

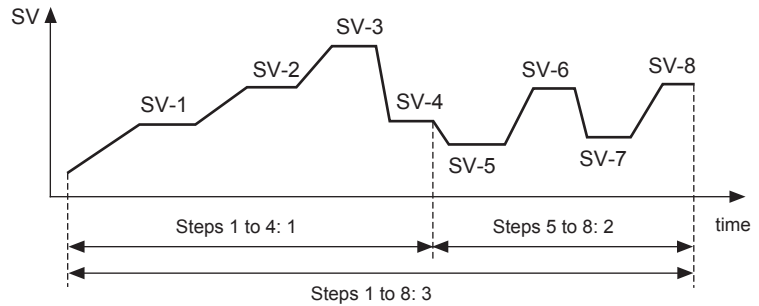

Note

- Do not change this parameter during the ramp soak operation. Be sure to set [PRoG] = "oFF" before changing the parameter.
- If you set [SV-H] and [SV-L] after setting SV, SV indicated during the ramp soak operation is limited while SV itself does not change.

[Setting example] Setting the Ramp soak Activation Pattern to steps 1 to 8

Display	Operating procedure
	1. Press and hold the SEL key for about three seconds during the SV/PV display. → P appears.
	2. Press the V key to display PtN.
	3. Press the SEL key. → The setpoint starts blinking.
	4. Press the ^ key to change "1" to "3."
	5. Press the SEL key or wait for three seconds to save the change.
	6. Press the F key. → The screen returns to the SV/PV display.

SV-1 to **SV-8** 1st target SV to 8th target SV (056 to 077)

tM1R to **tM8R** 1st ramp time to 8th ramp time (057 to 078)

tM1S to **tM8S** 1st soak time to 8th soak time (058 to 079)

[Description]

Sets the ramp soak SV, ramp time and soak time.

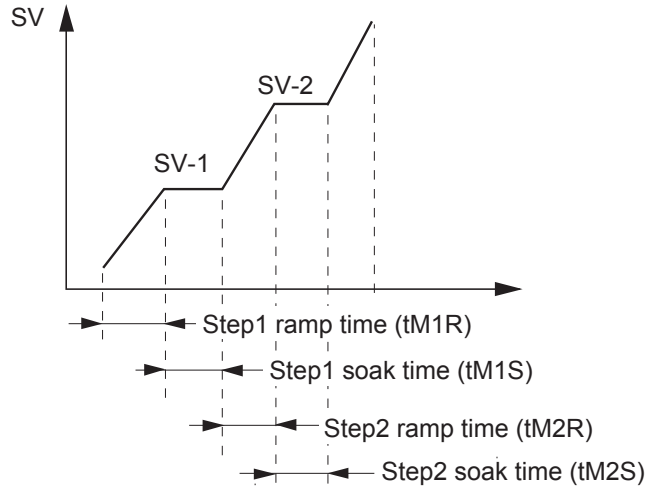

Parameter	Setting range
SV-1 to SV-8	SV lower limit (SV-L) to SV upper limit (SV-H) %FS
tM1R to tM8R	00.00 to 99.59
tM1S to tM8S	00.00 to 99.59

- The segment that both ramp time and soak time are set to 0.00 will be skipped.

[Example] In the example below, the step 2 is skipped.

SV-1: 50 SV-2: 200 SV-3: 100
 tM1R: 0.10 tM2R: 0.00 tM3R: 1.00
 tM1S: 0.05 tM2S: 0.00 tM3S: 0.75

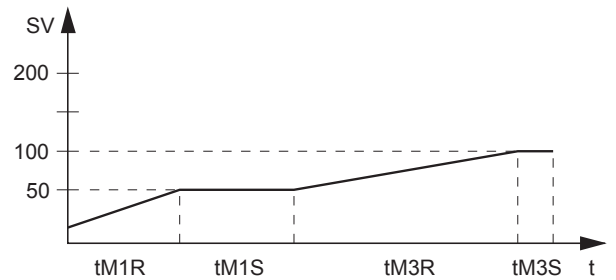

- The SV limit function ([SV-H], [SV-L]) is in effect while ramp soak is running. The set value (SV-n) does not change, but the value is limited during ramp soak. For the above reason, the value may not change at the set times and the ramp soak runs with the following pattern.

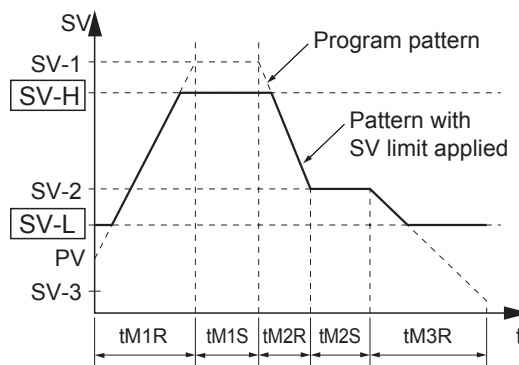

[Setting example] Setting SV1, ramp time, and soak time for step1

Display	Operating procedure
	1. Press and hold the SEL key for about three seconds during the SV/PV display. → <i>P</i> appears.
	2. Press the ▽ key to display <i>SV-1</i> .
	3. Press the SEL key. → The setpoint starts blinking.
	4. Press the ◀ , ▽ or ▲ keys to change “0” to “50.”
	5. Press the SEL key or wait for three seconds to save the change.
	6. Press the ▽ key to display <i>LM IR</i> .
	7. Press the SEL key. → The setpoint starts blinking.
	8. Press the ◀ , ▽ or ▲ keys to change “00.00” to “00.10.”
	9. Press the SEL key or wait for three seconds to save the change.
	10. Press the ▽ key to display <i>LM 15</i> .
	11. Press the SEL key. → The setpoint starts blinking.
	12. Press the ◀ , ▽ or ▲ keys to change “00.00” to “00.05.”
	13. Press the SEL key or wait for three seconds to save the change.
	14. Press the ☺ key. → The screen returns to the SV/PV display.

Mod Ramp soak mode (080)**[Description]**

Allows you to set the method of ramp soak operation.

- You can select from 16 options that are the combinations of the following four items.

Power-on start	Starts ramp soak with the current PV when the PXF is turned on.
END output	Maintains the same state as at the end of ramp soak when ramp soak is complete.
oFF output	Switches to the OFF state when ramp soak is complete.
Repeat	Repeats ramp soak from step 1 when the last step finishes.

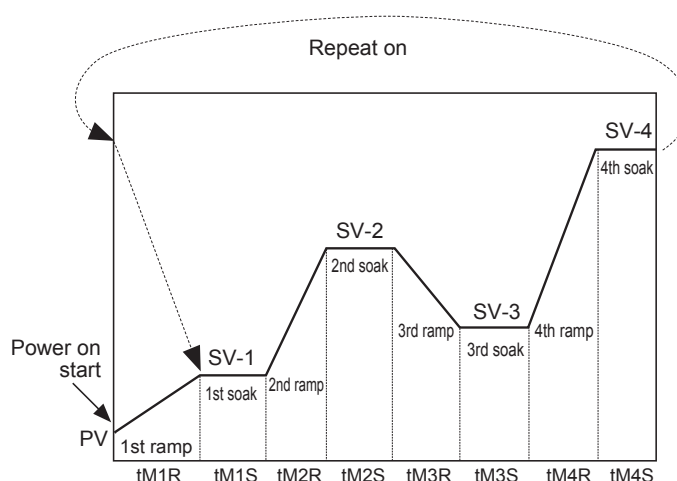





Setpoint	Power-on start	End output	oFF output	Repeat
0	off	Maintain control	Maintain control	off
1	off	Maintain control	Maintain control	on
2	off	Maintain control	Standby Mode	off
3	off	Maintain control	Standby Mode	on
4	off	Standby Mode	Maintain control	off
5	off	Standby Mode	Maintain control	on
6	off	Standby Mode	Standby Mode	off
7	off	Standby Mode	Standby Mode	on
8	on	Maintain control	Maintain control	off
9	on	Maintain control	Maintain control	on
10	on	Maintain control	Standby Mode	off
11	on	Maintain control	Standby Mode	on
12	on	Standby Mode	Maintain control	off
13	on	Standby Mode	Maintain control	on
14	on	Standby Mode	Standby Mode	off
15	on	Standby Mode	Standby Mode	on

- If the Repeat setting is off, the PXF retains the last SV after the ramp soak operation is over.

Parameter functions and setting procedure

[Setting example] Setting the ramp soak mode to 1

Display	Operating procedure
	<p>1. Press and hold the SEL key for about three seconds during the SV/PV display. → <i>P</i> appears.</p>
	
	<p>2. Press the ▽ key to display <i>Mod</i>.</p>
	<p>3. Press the SEL key. → The setpoint starts blinking.</p>
	<p>4. Press the △ key to change “0” to “1.”</p>
	<p>5. Press the SEL key or wait for three seconds to save the change.</p>
	<p>6. Press the ↵ key. → The screen returns to the SV/PV display.</p>

3-3 3rd block parameter

P-N1 Control action (090)

[Description]

This parameter specifies the control action and the output when an event occurs.



Setpoint	Control action	Burn-out output*
0	Reverse	Lower limit
1		Upper limit
2	Direct	Lower limit
3		Upper limit

* The output during burnout is as follows.

- Lower limit: The output is set to OFF, or 4mA or less.
- Upper limit: The output is set to ON, or 20mA or more.

[Setting example]

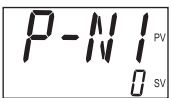
Changing the “Reverse/Lower limit for burn-out output” to the “Direct/Upper limit for burn-out output”

Display	Operating procedure
	<ol style="list-style-type: none"> 1. Press and hold the SEL key for about five seconds during the SV/PV display. → P-N1 appears.
	
	<ol style="list-style-type: none"> 2. Press the SEL key. → The setpoint starts blinking.
	<ol style="list-style-type: none"> 3. Press the ▲ key to change “0” to “3.”
	<ol style="list-style-type: none"> 4. Press the SEL key or wait for three seconds to save the change.
	<ol style="list-style-type: none"> 5. Press the ☺ key. → The screen returns to the SV/PV display.

Parameter functions and setting procedure

SV-L SV (Set value) lower limiter (091)

SV-H SV (Set value) upper limiter (092)

[Description]

These parameters specify the setting range of the SV. You can set any value within the measurement range.

Setting range

0 to 100%FS

- The relationship between SV limits and the measurement range is as shown in the right figure:

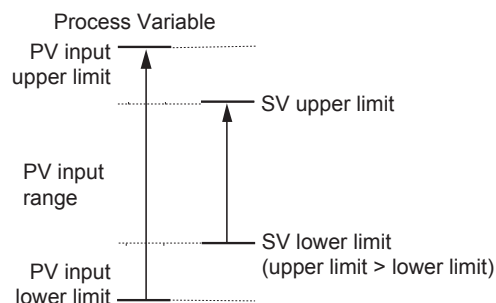

Caution

- Set [P-SL], [P-SU], and [P-dP] before setting SV-L and SV-H. (see page 43 to 45)
- SVs set before setting the SV limits (Local SV, etc.) are affected by new SV limits.
- Make sure to set the value of [SV-H] greater than [SV-L].

[Setting example] Setting the lower SV limit to 50°C

Display	Operating procedure
	1. Press and hold the SEL key for about five seconds during the SV/PV display. → <i>P-N I</i> appears.
	2. Press the ▽ key to display <i>SV-L</i> .
	3. Press the SEL key. → The setpoint starts blinking.
	4. Press the ◀ or ▶ keys to change “0” to “50.”
	5. Press the SEL key or wait for three seconds to save the change.
	6. Press the ☺ key. → The screen returns to the SV/PV display.

dLY1 **dLY2** Delay time 1, 2 (093, 094)

A1Hy **A2Hy** Alarm 1, 2 hysteresis (098, 099)

[Description]

Parameter	Description	Setting range
dLY1, dLY2	Specifies the amount of time from the occurrence of the alarm to the sounding of the alarm	0 to 9999 (sec)
A1Hy, A2Hy	Specifies alarm detection width and recovery width.	0 to 50%FS

- The alarm and hysteresis are related as follows.

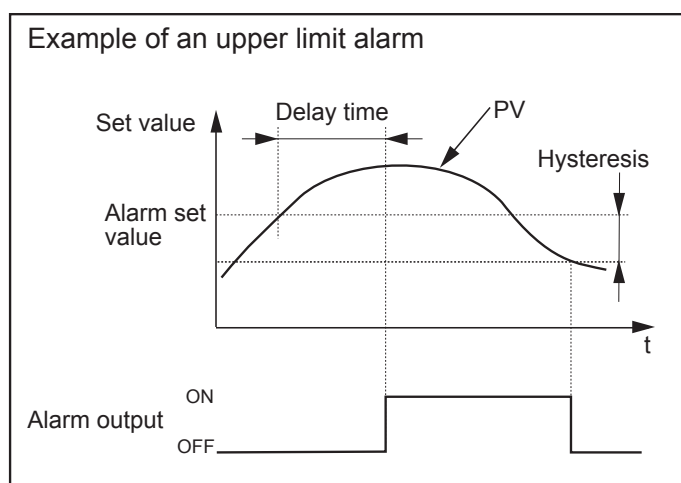

Upper limit alarm

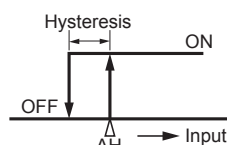

Lower limit alarm

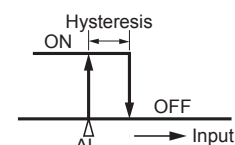



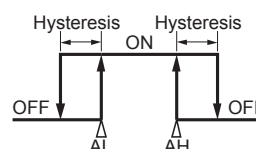





Zone alarm



[Setting example] Setting the Alarm 1 hysteresis to 5°C, delay time to 30 seconds —

Display	Operating procedure
	1. Press and hold the SEL key for about five seconds during the SV/PV display. →P-N I appears.
	2. Press the ▽ key to display dLY1 .
	3. Press the SEL key. →The setpoint starts blinking.
	4. Press the ◀ or ▶ keys to change “0” to “30.”
	5. Press the SEL key or wait for three seconds to save the change.

Parameter functions and setting procedure

Display	Operating procedure
	6. Press the  key to display <i>R 114.4</i> .
	7. Press the  key. →The setpoint starts blinking.
	8. Press the  or  keys to change “1” to “5.” 9. Press the  key or wait for three seconds to save the change. 10. Press the  key. →The screen returns to the SV/PV display.

A1oP **A2oP** Alarm 1, 2 options (101, 102)

[Description]

You can set the optional functions to the alarm 1 and the alarm 2, if you need. The three types of optional functions are assigned for each bit.

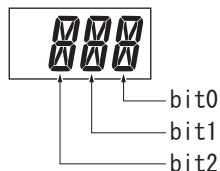

bit	Function	Setpoint
bit0	Alarm latch: Latches (maintains) the state when an event occurs.	0 (OFF) 1 (ON)
bit1	Input error alarm: Outputs when an input error (“UUUU” or “LLLL” is displayed) occurs. Set the alarm type to “0” to use this function.	0 (OFF) 1 (ON)
bit2	Inverted output function: Inverts the output and open the contact during an event occurs.	0 (OFF) 1 (ON)

[Setting example]

Adding the alarm latch and the converted output function to the alarm 1

Display	Operating procedure
	1. Press and hold the SEL key for about five seconds during the SV/PV display. → <i>P-N I</i> appears.
	2. Press the ▽ key to display <i>A1oP</i> .
	3. Press the SEL key. → The setpoint starts blinking.
	4. Press the ◀ , ▽ or ▶ keys to change “000” to “101.”
	5. Press the SEL key or wait for three seconds to save the change.
	6. Press the ☺ key. → The screen returns to the SV/PV display.

Parameter functions and setting procedure

PLC1 PHC1 OUT1 Upper/Lower Limits (104, 105)

[Description]

This parameter specifies the upper and lower limits for output control.

Parameter		Setting range
Lower limit	Upper limit	
PLC1	PHC1	-5.0 to 105.0 (%)

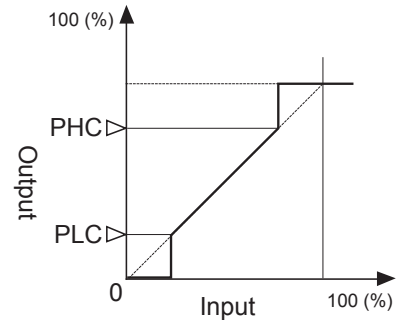

Related parameters: Output limit types [PCUt] (see page 63)

Note Be sure to set the values so that PHC is greater than PLC.

[Setting example] Setting the OUT1 lower limit to 5.0%

Display	Operating procedure
	1. Press and hold the SEL key for about five seconds during the SV/PV display. → <i>P-N I</i> appears.
	2. Press the ▽ key to display <i>PLC 1</i> .
	3. Press the SEL key. → The setpoint starts blinking.
	4. Press the △ key to change “-5.0” to “5.0.”
	5. Press the SEL key or wait for three seconds to save the change.
	6. Press the ☺ key. → The screen returns to the SV/PV display.

PCUt Output limit types (108)**[Description]**

You can choose whether to apply the limit on the output value or let it exceed the limit.

Setpoint	Lower limit	Upper limit
0	-5%	105%
1	limit	105%
2	-5%	limit
3	limit	limit

- The output changes according to the limit, as follows.

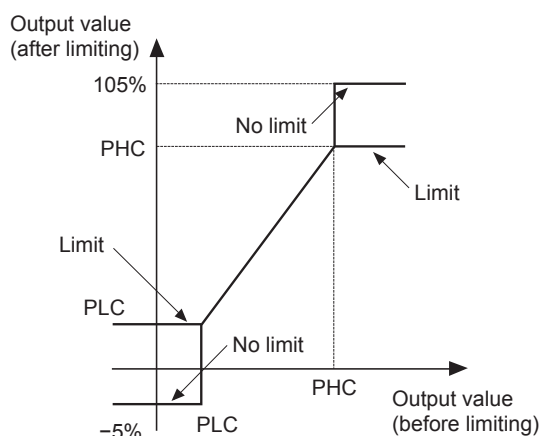
**[Setting example]** Setting the high and low limit setting to "limit"

Display	Operating procedure
	1. Press and hold the SEL key for about five seconds during the SV/PV display. → P-N I appears.
	2. Press the ▽ key to display PCUt.
	3. Press the SEL key. → The setpoint starts blinking.
	4. Press the ▽ or △ keys to change "0" to "3."
	5. Press the SEL key or wait for three seconds to save the change.
	6. Press the ☺ key. → The screen returns to the SV/PV display.







Parameter functions and setting procedure

oUt1 Output value (MV) display (109)

[Description]

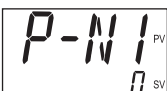
Displays the output value (OUT1).

[Setting example] Checking the output value (OUT1)

Display	Operating procedure
	1. Press and hold the  key for about five seconds during the SV/PV display. → <i>P-N I</i> appears.
	
	2. Press the  key to display <i>out 1</i> . → The output value of OUT1 appears.
	3. Press the  key. → The screen returns to the SV/PV display.





RCJ RCJ (Cold junction compensation) setting (111)**[Description]**

This is the procedure for turning the cold junction compensation on or off when using the input from a thermocouple sensor.

Setpoint	Description
oN	Cold junction compensation on
oFF	Cold junction compensation off

- This setting should be left “oN” during normal operation. It should only be turned off when cold junction compensation is being performed externally or you wish to record temperature differences.

[Setting example] Setting the cold junction compensation to OFF

Display	Operating procedure
	1. Press and hold the SEL key for about five seconds during the SV/PV display. →P-N I appears.
	
	2. Press the ▽ key to display <i>RCJ</i> .
	3. Press the SEL key. →The setpoint starts blinking.
	4. Press the ◀ , ▽ or ▲ keys to change “oN” to “oFF.”
	5. Press the SEL key or wait for three seconds to save the change.
	6. Press the ☺ key. →The screen returns to the SV/PV display.

Parameter functions and setting procedure

AdJ0 User-definable zero adjustment (113)

AdJS User-definable span adjustment (114)

[Description]

This is the procedure for adjusting the zero point and the span for PV.

Setting range

-50 to 50%FS

- Set the following equipment before using these parameters or starting adjustment.
 - MV Generator: 1V to 5V (for voltage/current input), 0mV to 100mV (for thermocouple input)
 - Dial resistance unit: 100.0 to 400.0Ω (for resistance thermometer bulb input)

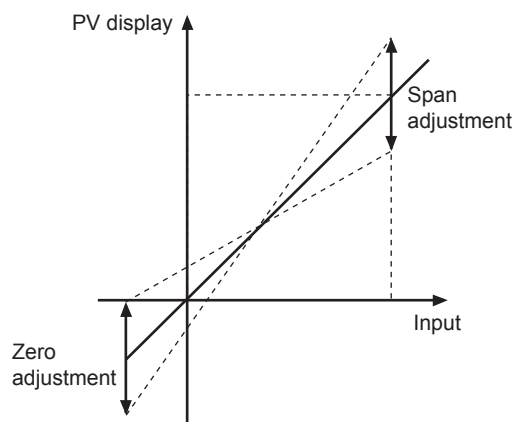





Note

- Set the zero/span adjustment value to “0” to restore the factory setting.
- The user correction function operates independently from the controller adjustment value. Setting this value to “0” returns the settings to the factory settings.

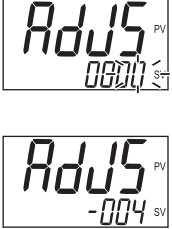
[Setting example] Correcting an error of -3°C in the zero point and 4°C in the span —

Display	Operating procedure
	1. Press and hold the SEL key for about five seconds during the SV/PV display. → <i>P-N I</i> appears.
	2. Press the ▽ key to display <i>AdJ0</i> .
	3. Press the SEL key. → The setpoint starts blinking.
	4. Press the △ key to change “0” to “3.”
	5. Press the SEL key or wait for three seconds to save the change.
	6. Press the ▽ key to display <i>AdJ5</i> .

Display	Operating procedure
	<ol style="list-style-type: none"><li data-bbox="432 226 863 309">7. Press the  key. →The setpoint starts blinking.<li data-bbox="432 365 986 405">8. Press the  key to change “0” to “-4.”<li data-bbox="432 495 1235 535">9. Press the  key or wait for three seconds to save the change.<li data-bbox="432 555 1015 638">10. Press the  key. →The screen returns to the SV/PV display.

Parameter functions and setting procedure

dSP1 to dP14 Parameter mask (126 to 139)

[Description]

The parameter mask allows you to hide unused parameters or to skip over the parameters you want to keep their setpoints.

Note

Do not let the parameters which are not described in this operation manual appear on the screen.

- Each parameter has the mask DSP which is the combination of a code (dSP1 to dSP9, dP10 to dP14) and an integer, connected with a hyphen. For example, the mask DSP for the integral time [i] is “dSP3-4”, which is a combination of the code “dSP3” and an integer “4.”
- **To hide one parameter:**
Convert the integer of the mask DSP of the parameter you want to hide into a hexadecimal number.
For example, if you want to hide the integral time [i], of which mask DSP is dSP3-4, set the parameter [dSP3] to “0004.”
- **To hide multiple parameters of the same code:**
Convert the total of the two integers into a hexadecimal number.
For example, if you want to hide the integral time [i] (dSP3-4) and the deviation time [d] (dSP3-8), the total of two integers is “12.” Set the parameter [dSP3] to “000C,” which is the hexadecimal of 12.

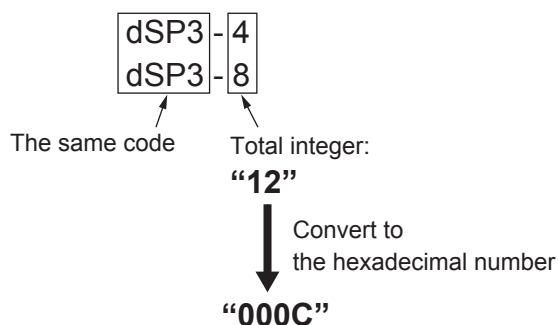













- **To reshow a parameter that has been hidden:**
Subtract the integer of the mask DSP of the parameter you want to reshow from the set value. Set the parameter to the hexadecimal of the subtracted value.
For example, if you want to reshow the deviation time [d] (dSP3-8) when the [dSP3] is set to “000C” which is the hexadecimal of “12,” change the setting of [dSP3] to “0004” which is the hexadecimal of “4.”
- See “2-3 Parameter List” for the mask DSP of each parameter.(page 15 to 18)

[Setting example] Hiding the integral time [i] and the derivative time [d] _____

<Preparations>

- Check the mask DSP of the parameter(s) you want to hide.
(the mask DSP of the integral time [i] is “dSP3-4,” the mask DSP of the derivative time [d] is “dSP3-4.”)
- If you want to hide multiple parameters of the same code, calculate the hexadecimal number of the total integer.





Display	Operating procedure
	<p>1. Press and hold the  key for about five seconds during the SV/PV display. → P-N I appears.</p>
	
	<p>2. Press the  key to display dSP I.</p>
	<p>3. Press the  key. → The setpoint starts blinking.</p>
	<p>4. Press the ,  or  keys to change “0000” to “000C.”</p>
	<p>5. Press the  key or wait for three seconds to save the change.</p> <p>6. Press the  key. → The screen returns to the SV/PV display.</p> <p>The integral time [i] and the derivative time [d] are hidden. If you want to reshown the derivative time [d], carry out the steps 1 to 3, and then change the setpoint from “000C” to “0004.”</p>

Parameter functions and setting procedure

UKy1 UKy2 UKy3 USER key assignment (143, 144, 145)

[Description]











Allows you to assign a function to the  (USER) key.

Parameter	Key assignment	Setting range
UKy1	 (USER) key	0 to 6
UKy2	 (USER) key and  key	
UKy3	 (USER) key and  key	

- Select a function from the table below.

Setpoint	Function
0	No function
1	Switchover between STBY ON/OFF
2	Switchover between Auto/Manual
3	Unavailable
4	Unavailable
5	Starts AT (Auto-tuning) (standard)
6	Starts AT (Auto-tuning) (low PV)

[Setting example] Assigning the standby on/off switching function to the USER key —

Display	Operating procedure
	<ol style="list-style-type: none"> 1. Press and hold the  key for about five seconds during the SV/PV display. → P-N I appears. 2. Press the  key to display UKY 1. 3. Press the  key. → The setpoint starts blinking. 4. Press the  key to change “0” to “1.” 5. Press the  key or wait for three seconds to save the change. 6. Press the  key. → The screen returns to the SV/PV display.
	
	
	
	



FLo1 MV1 during FALT (146)**[Description]**

Allows you to specify the control output value when the controller falls into FALT (input error).

Setting range

-5.0 to 105.0%

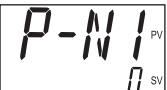
[Setting example] Setting the OUT1 during FALT to 5%

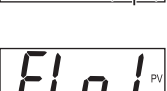
Display	Operating procedure
	<p>1. Press and hold the SEL key for about five seconds during the SV/PV display. → <i>P-N I</i> appears.</p>
	
	<p>2. Press the ▽ key to display <i>FLo I</i>.</p>
	<p>3. Press the SEL key. → The setpoint starts blinking.</p>
	<p>4. Press the ◀, ▽ or ▶ keys to change “-5.0” to “5.0.”</p>
	<p>5. Press the SEL key or wait for three seconds to save the change.</p> <p>6. Press the ☺ key. → The screen returns to the SV/PV display.</p>

Parameter functions and setting procedure

dSPt PV/SV display OFF (148)





[Description]

This parameter is used to manually turn off the PV, SV, and LED lamps on PV/SV screen.

Setpoint	Function
0	PV, SV, and LED lamps stay ON
1	SV display OFF
2	PV display OFF
3	PV and SV displays OFF
4	PV, SV, and LED lamps OFF (all off)
5	SV display OFF (relights for 5 sec by pressing any key)
6	PV display OFF (relights for 5 sec by pressing any key)
7	PV and SV displays OFF (relights for 5 sec by pressing any key)
8	PV, SV, and LED lamps OFF (all off) (relights for 5 sec by pressing any key)

- If an input error or an alarm occurs during the settings 5 to 8, the displays and lamps stay ON even after 5 seconds.
- If an input error or an alarm occurs during the settings 5 to 8, PV and/or SV will be turned on again.

[Setting example] Turning off the PV display

Display	Operating procedure
	<ol style="list-style-type: none"> 1. Press and hold the SEL key for about five seconds during the SV/PV display. → P-N I appears. 2. Press the ▽ key to display dSPt. 3. Press the SEL key. → The setpoint starts blinking. 4. Press the △ key to change “0” to “2.” 5. Press the SEL key or wait for three seconds to save the change. 6. Press the ☺ key. → The screen returns to the SV/PV display.
	
	
	
	

4 Troubleshooting

When a trouble occurs, first check the model, wiring, and parameter settings. The following table shows some typical cases and their solutions.

Symptoms	Causes	Remedies	Reference pages
Parameters you want to view do not appear	Display mask is set.	Check the DSP settings.	Page 68
Control output is not output even with the power turned on	The ramp soak settings have the output turned OFF.	Check the ramp soak settings.	Page 22 Page 55
	Standby mode is on.	Check the output settings during standby mode.	Page 21
Keys do not work	Other than “0” is set in the parameter of [LoC].	Check the key lock settings.	Page 29
	SV limit value is set.	Check the SV limit value settings.	Page 58
	The ☺ (USER) key settings have changed.	Check the ☺ (USER) key settings.	Page 70
The display has shown “UUUU” or “LLLL”	The setting of [P-N2] is not correct for the input signals of sensors or others.	Set the parameter of [P-N2] correctly.	Page 42
	The polarity of the sensor does not match that of this controller.	Correct the polarity of the sensor and this controller.	—
	Input terminals are short-circuited in thermocouple B or R. ([P-N2]=“4”, “5”)	Set the parameter of [P-N2] to “3”, and check if the temperature around an ordinary temperature is displayed. (Thermocouples B and R have a large error around ordinary temperatures. However, this is not a fault.)	Page 42
	The connecting cables for the sensor are loose.	Tighten the connecting cables.	—
	A break or short-circuit occurred in the sensor.	Replace the sensor with a new one. Or remove the short-circuit.	—
	The sensor or other input devices that are connected to this controller have problems.	Replace the sensor with a new one. Or remove the short-circuit.	—
	The set value of the parameter of [P-SL] is larger than the value of [P-SU].	Set the parameters again so that the value of [P-SL] is smaller than the value of [P-SU].	Page 43
	The process variable is too large or too small.	Set the parameters again so that the difference of the set values of [P-SL] and [P-SU] is made larger.	Page 43

Troubleshooting

Symptoms	Causes	Remedies	Reference pages
“Err” has been displayed.	The value of [P-SU] is set to 3277°C or more for thermocouple and resistance bulb input.	Set the parameters of [P-SL] and [P-SU] again according to the input range table.	Page 43
	The measured range ([P-SU] to [P-SL]) is set to 10000 or more for voltage and current input.	Set the parameters of [P-SL] and [P-SU] again so that the measured range is 9999 or less.	Page 43
A decimal point has not been displayed.	“0” is set in the parameter of [P-dP].	Set the parameter of [P-dP] to “1” to “3”.	Page 45
The SV or the set values of some parameters have been changed without any operation.	The parameter of [P-SL], [P-SU], or [P-dP] was changed.	Set all the parameters again. (If you change [P-SL], [P-SU], or [P-dP], the setpoints of the parameters of which measurement range is the industrial value (those shaded in the Parameter List) automatically change.)	Page 15 to 18
	When the set value of [P-SU] is larger than 1000, “1” is registered for [P-dP].	Set [P-dP] to “0”, and return [P-SU] to an original value.	Page 45 Page 43
ON/OFF (2-position) control has not function properly.	Other than “oNoF” is set in the parameter of [CtRL].	Set the parameter [CtRL] to “oNoF.”	Page 36
	The setpoint of the parameter [P] is “0.1” or greater.	Set the parameter [P] to “0.0.”	Page 30
ON/OFF (2-position) control has not function properly.	The set value of parameter [HyS] is not correct.	Adjust the set value of parameter [HyS] to be suitable for the device to be controlled.	Page 32
	The setting of parameter [oNoF] is not correct.	Set the parameter [oNoF] correctly.	Page 40
The Micro-controller is not controlling properly.	The set values of the parameters [P], [i], and [d] are not correct.	Perform the auto-tuning.	Page 25
	The cycle times are too long.	Decrease the set value of the parameter [tC] gradually.	Page 41
	Output is limited.	Set the parameters of [PLC1] and [PHC1] again to be suitable for the process.	Page 62
	Output is not limited correctly.	Set the parameters of [PCUt] again to be suitable for the process.	Page 63

Symptoms	Causes	Remedies	Reference pages
Response is too slow. Output changes between ON and OFF, but the reading does not change.	Input filter constant is too large.	Decrease the set value of the parameter of [P-dF].	Page 48
	Some input terminals are short-circuited.	Remove the short-circuited terminals.	—
	The connecting cable for the device to be controlled are not connected properly.	Connect it properly.	—
	The device to be controlled has powered off.	Power it on.	—
	The output signals of this controller do not match the input signals of the device to be controlled.	Prepare this controller to be suitable for the device to be controlled. Or select the device to be controlled to be suitable for this controller.	—
The SV cannot be changed.	“1” or “4” is set in the parameter of [LoC].	Set the parameter of [LoC] to “0”, “2”, “3” or “5”.	Page 29
	You have tried to set the value that is outside of the SV limiter (Parameters of [SV-L] and [SV-H]).	Widen the range between [SV-L] and [SV-H]. (However, it should be within the set range in the input range table.)	Page 58
	The ramp soak control is ongoing (RUN or HLd), or completed (ENd).	Set the parameter of [ProG] to “oFF.”	Page 22
Auto-tuning does not work properly.	After starting the auto-tuning operation, the display has shown “UUUU” or “LLLL.”	Set the parameters again so that the difference of the set values of [P-SL] and [P-SU] is made larger, and perform the auto-tuning again.	Page 43
	You have changed the SV after starting the auto-tuning operation.	Set the desirable SV, and perform the auto-tuning again.	Page 25
	You have tried to perform the auto-tuning during ramp soak operation.	Set the parameter of [ProG] to “oFF,” and perform the auto-tuning again.	Page 22
	Peripheral devices have problems. Or they are not connected properly.	Connect them properly.	—
	Normal/reverse actions are not suitable for the operations of the device to be controlled.	Set the parameter of [P-N1] properly.	Page 57
	The response of the controlled device was too slow, and the auto-tuning did not finish in 9 hours.	Perform the tuning manually. (Set the parameter of [P] to “0.0” to try the ON/OFF control.)	Page 30
An excessive overshoot has occurred during auto-tuning operation.	—	Perform the auto-tuning with the parameter of [At] being “L-oN” (Low PV type).	Page 25
	—	Perform the tuning manually.	—
The self-tuning does not work properly.	See the section of the parameter of [CTRL].		Page 36



Gate City Ohsaki, East Tower, 11-2, Osaki 1-chome, Shinagawa-ku, Tokyo 141-0032, Japan
Phone: +81-3-5435-7111
www.fujielectric.com
www.fujielectric.com/products/instruments/
