



Description

AquaMetrix pH and ORP differential probes stay in service and provide accurate measurements under conditions that often render conventional pH probes inoperable. Now for added versatility, these probes, field-proven in hundreds of installations, are available with an integral encapsulated 4-20 mA two-wire transmitter to feed directly to a PLC or a DCS.

The P65 pH and R65 ORP probes employ a differential measurement technique. Unlike conventional combination probes, the differential probe has two high impedance measurement circuits containing a common metallic return electrode. One circuit includes the process measurement electrode which generates a potential E_1 proportional to the process pH. The second circuit includes an internal measurement electrode immersed in a stable buffer solution which generates a standard reference potential, E_2 . Both circuits have a common potential E_3 developed at the return electrode. The two circuits are fed into amplifiers which provide an output representing the differential between them:

$(E_1 - E_3) - (E_2 - E_3)$. The common potential E_3 is cancelled out electronically, greatly reducing inaccuracies caused by ground loops which may exist between process and instrument grounds. Ground loop current will flow through the low impedance path of the return electrode, affecting the potential E_3 , but not the differential measurement.

The differential probe maintains its accuracy and stability in aggressive process applications long after a combination-style probe's performance begins to deteriorate.

Maintenance costs are reduced and the life of the probe is increased. The internal reference electrode is electrically connected to the process solution by means of a field-replaceable double junction salt bridge which greatly reduces the possibility of contamination of the buffer solution in the reference circuit. Although seldom required, the reference solution may be easily replaced by removing the screw-out salt bridge. A salt bridge and buffer kit is available for this purpose.

Another advantage of the 65 series is the semi-flush face which is easily cleaned and avoids solution materials gathering on protrusions found in competitive probes. The domed glass electrode, the protective metal electrode and the temperature sensor protrude only about 1/8 inch while the salt bridge is flush. A flat-face version of the pH probe is also available.

The 65 series can be provided in any of the physical configurations in the P60/R60 series differential probes: 65C-8 with 1-1/2" threaded body style, 65C-6 "Easy-In, Easy-Out" variable insertion depth version with 1- 1/4" NPT compression fitting, or the 65C-7 hot tap version.

Features

Two-Wire Transmitter built in

- Integral two-wire 4-20 mA transmitter can be fed directly to PLC, DCS

Differential Measurement

- Replaceable Salt Bridge
- Long-lasting
- Low Maintenance Cost
- Field-proven
- Reduces ground loop problems

Easy Cleaning

- Semi-flush face: reduced buildup

Temperature Compensation

- Automatic temperature compensation on pH versions

Options

- Flow-through and submersion
- Hot-Tap available
- Flat-faced available (pH)
- Gold electrode available (ORP)
- Differential pH & ORP versions without 2 wire transmitter available (see P/R60 series)

Applications

- Process Control
- Industrial and Municipal Water Treatment
- Industrial and Municipal Waste Treatment and Neutralization
- Fume Scrubbers, Plating, Circuit Board Manufacturing, Food and Beverage, Chemical Processing, Pulp and Paper, Mining, Power Generation, Pharmaceutical Industry

Model P65C/R65C pH or ORP Probes with 4-20 mA Output

Technical Data

Measuring Range	
pH	0 to 14 pH (Consult factory for applications below 2 or above 12).
ORP	-500 to +500 mV or 0 mV to +1000 mV, field selectable
Flow Rate	
	10 ft./sec maximum (3 metres/sec) Flow should be as low as possible in low conductivity water and in solutions with high suspended solids
Wetted Materials	
	CPVC, kynar, glass, titanium palladium alloy and EPDM (platinum for ORP probe); opt. viton and ceramic
Transmission Distance	
	Dependant upon transmission distance and supply voltage
Sensitivity	
pH	0.001 pH
ORP	0.1 mV
Stability	
pH	0.03 pH per day, non-cumulative
ORP	2 mV per day, non-cumulative
Temperature Compensation	
Automatic	-5 to 95°C (23 to 203°F)
Pressure Limit	
	100 psig at 65°C maximum
Temperature Limits	
CPVC	-5 to 95°C (23 to 203°F) The temperature limit of probes in flow-through applications is limited by pressure and by the pipe fitting material.
Probe Cable	5 Conductor plus shield, 15 ft. (4.6m) long

Dimensions

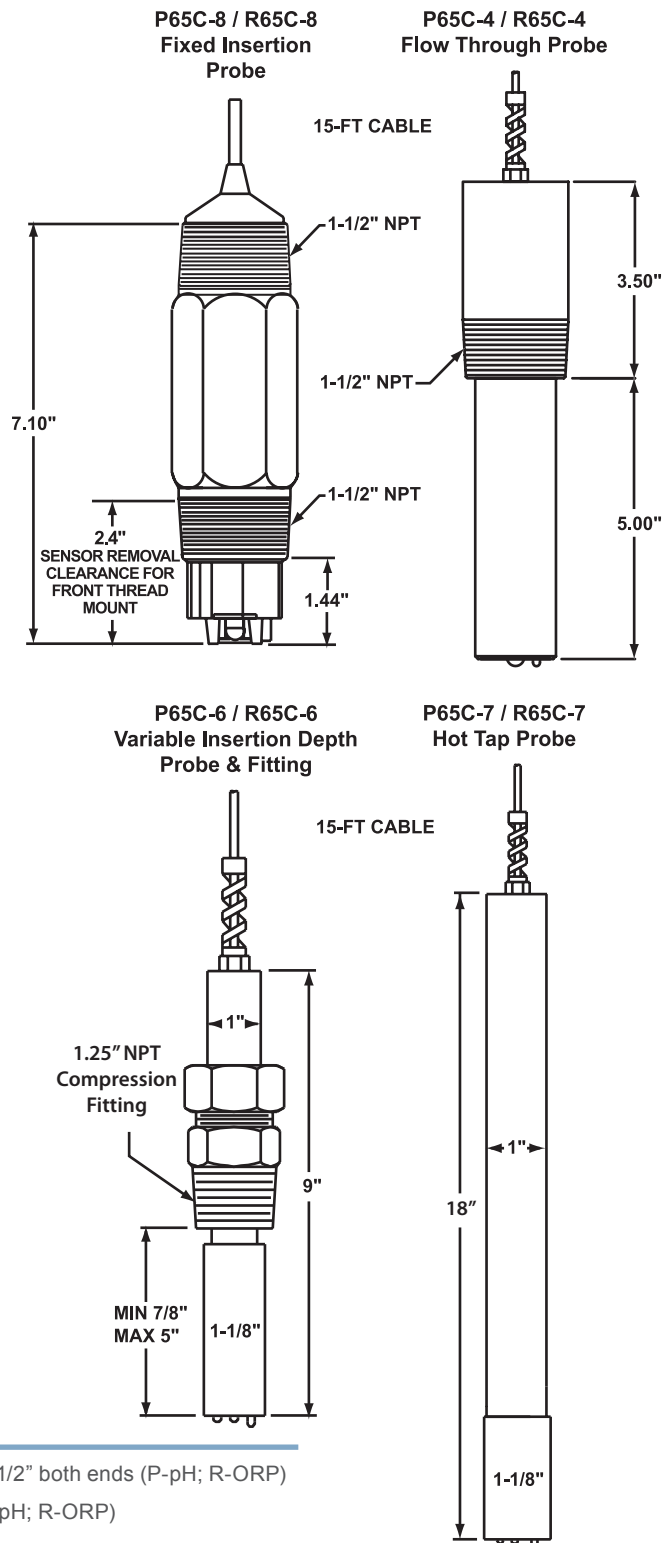

Related Products

CABLES & ACCESSORIES

JB1	NEMA 4X junction box
C42-1-XXX	Interconnect cable; dressed both ends - specify length
C35-17(K)	Salt Bridge Kit for P/R65C-4/-6/-7 probes, package of 3
AM60-9765K	Salt Bridge Kit, all P/R65C-8 probes, package of 3
P60-HTC	Hot Tap Ball Valve assembly

CALIBRATION SOLUTIONS

A35-13	pH 4 Buffer, 500 mL.
A35-14	pH 7 Buffer, 500 mL
A35-24	pH 10 Buffer, 500 mL
A35-40	ORP Buffer, 200 mV, 500 mL
A35-41	ORP Buffer, 600 mV, 500 mL

Ordering Information

P/R65C-8	Flow-through or submersion applications; body threaded 1-1/2" both ends (P-pH; R-ORP)
P/R65C-6	"Easy-in Easy out" variable insertion depth, 1-1/4" fitting (P-pH; R-ORP)
P/R65C-7	For use with Hot-Tap hardware (P-pH; R-ORP)
P65C-8-F	Flat-Face pH probe
P65C-8-A	Antimony pH probe
R65C-8-G	ORP probe with Gold electrode