

# Photoelectrics Retro-reflective, Polarized Type PD32CNP25

CARLO GAVAZZI



- Miniature sensor range
- Range: 2.5 m, with reflector
- Sensitivity adjustment by Teach-In programming
- Modulated, red light 660 nm, polarized
- Supply voltage: 10 to 30 VDC
- Output: 100 mA, NPN or PNP preset
- Make and break switching function programmable
- LED for output indication and power ON
- Protection: reverse polarity, short circuit and transients
- Cable and plug versions
- Compact housing
- Excellent EMC performance

## Product Description

The PD32CNP25 sensor family comes in a compact 12 x 32 x 20 mm reinforced PMMA/ABS-housing. The sensors are useful in applications where high-accuracy detection as well as small size is required.

The Teach-In function for adjustment of the sensitivity makes the sensors highly flexible. The output type is preset (NPN or PNP), and the output switching function is programmable (NO or NC).

## Ordering Key

**PD32CNP25PPM5T**

Type	_____
Housing style	_____
Housing size	_____
Housing material	_____
Housing length	_____
Detection principle	_____
Sensing distance	_____
Output type	_____
Output configuration	_____
Connection type	_____
Teach-In	_____

## Type Selection

Housing W x H x D	Range S <sub>n</sub>	Ordering no. NPN & PNP cable Make & break switching	Ordering no. NPN & PNP plug Make & break switching
12 x 32 x 20 mm	2.5 m	PD 32 CNP 25 NPT PD 32 CNP 25 PPT	PD 32 CNP 25 NPM5T PD 32 CNP 25 PPM5T

## Specifications

<b>Rated operating distance (S<sub>n</sub>)</b>	Up to 2.5 m, with reflector 51 x 51 mm (ER5060)	<b>Light source</b>	GaAIAs, LED, 660 nm
<b>Blind zone</b>	5 mm	<b>Light type</b>	Red, modulated
<b>Sensitivity</b>	Adjustable by Teach-In (push button or wire)	<b>Sensing angle</b>	± 2°
<b>Temperature drift</b>	≤ 1%/°C	<b>Ambient light</b>	5,000 lux
<b>Hysteresis (H) (differential travel)</b>	≤ 10%	<b>Light spot</b>	75 x 75 mm @ 1.5 m
<b>Rated operational volt. (U<sub>B</sub>)</b>	10 to 30 VDC (ripple included)	<b>Operating frequency</b>	1000 Hz
<b>Ripple (U<sub>ripple</sub>)</b>	≤ 10%	<b>Response time</b>	
<b>Output current</b>		OFF-ON (t <sub>ON</sub> )	≤ 0.5 ms
Continuous (I <sub>a</sub> )	≤ 100 mA	ON-OFF (t <sub>OFF</sub> )	≤ 0.5 ms
Short-time (I)	≤ 100 mA (max. load capacity 100 nF)	<b>Power ON delay (t<sub>v</sub>)</b>	≤ 300 ms
<b>No load supply current (I<sub>o</sub>)</b>	≤ 25 mA @ 24 VDC	<b>Output function</b>	
<b>Minimum operational current (I<sub>m</sub>)</b>	0.5 mA	NPN and PNP	Preset
<b>OFF-state current (I<sub>r</sub>)</b>	≤ 100 μA	NO/NC switching function	Set up by button
<b>Voltage drop (U<sub>d</sub>)</b>	≤ 2.4 VDC @ 100 mA	<b>External Teach</b>	
<b>Protection</b>	Short-circuit, reverse polarity and transients	Same function as button	10 to 30 VDC
		Locked (disable teach button)	0 to 2.5 VDC
		Operating mode	Not connected
		<b>Indication</b>	
		Output ON	LED, yellow
		Signal stability ON and power ON	LED, green
		<b>Environment</b>	
		Installation category	II (IEC 60664/60664A; 60947-1)

## Specifications (cont.)

Pollution degree	3 (IEC 60664/60664A; 60947-1)	<b>Housing material</b>	ABS, black PMMA, red
Degree of protection	IP 67 (IEC 60529; 60947-1)	Body Front material	
<b>Ambient temperature</b>		<b>Connection</b>	PUR, black, 2 m 4 x 0.14 mm <sup>2</sup> , Ø = 3.6 mm M8, 4-pin
Operating	-20° to +60°C (-4° to +140°F)	Cable	
Storage	-20° to +80°C (-4° to +176°F)	Plug	
<b>Vibration</b>	10 to 55 Hz, 0.5 mm/7.5 g (IEC 60068-2-6)	<b>Weight</b>	With cable: 40 g With plug: 10 g
<b>Shock</b>	30 g / 11ms, 3 pos, 3 neg per axis (IEC 60068-2-6, 60068-2-32)	<b>CE-marking</b>	Yes
<b>Rated insulation voltage</b>	500 VAC (rms)	<b>Approval</b>	cUL

## Operation Diagram

tv = Power ON delay

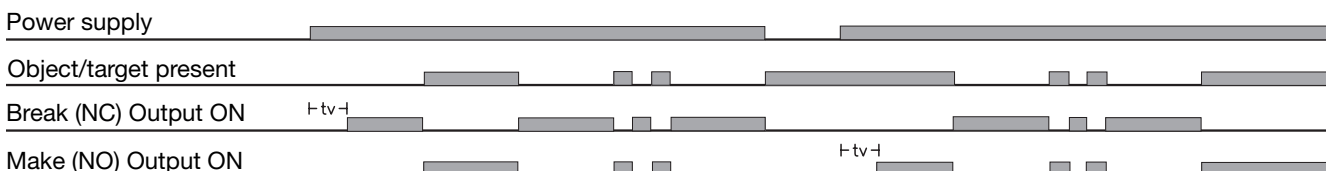

## Wiring Diagrams

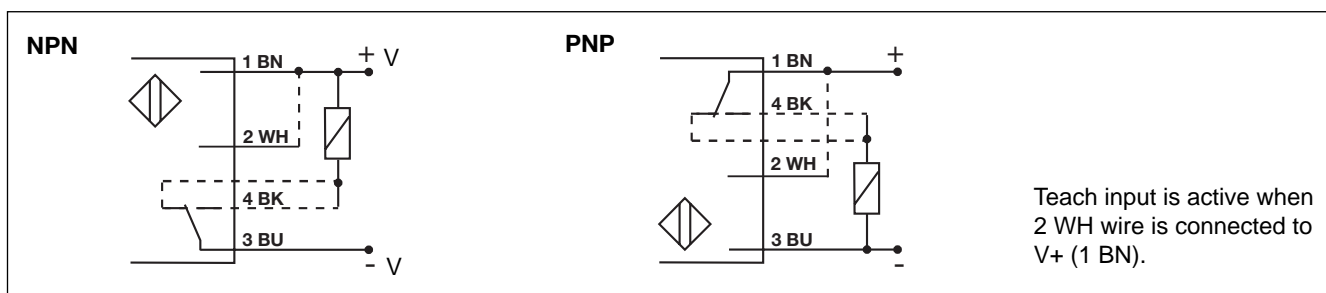

## Dimensions

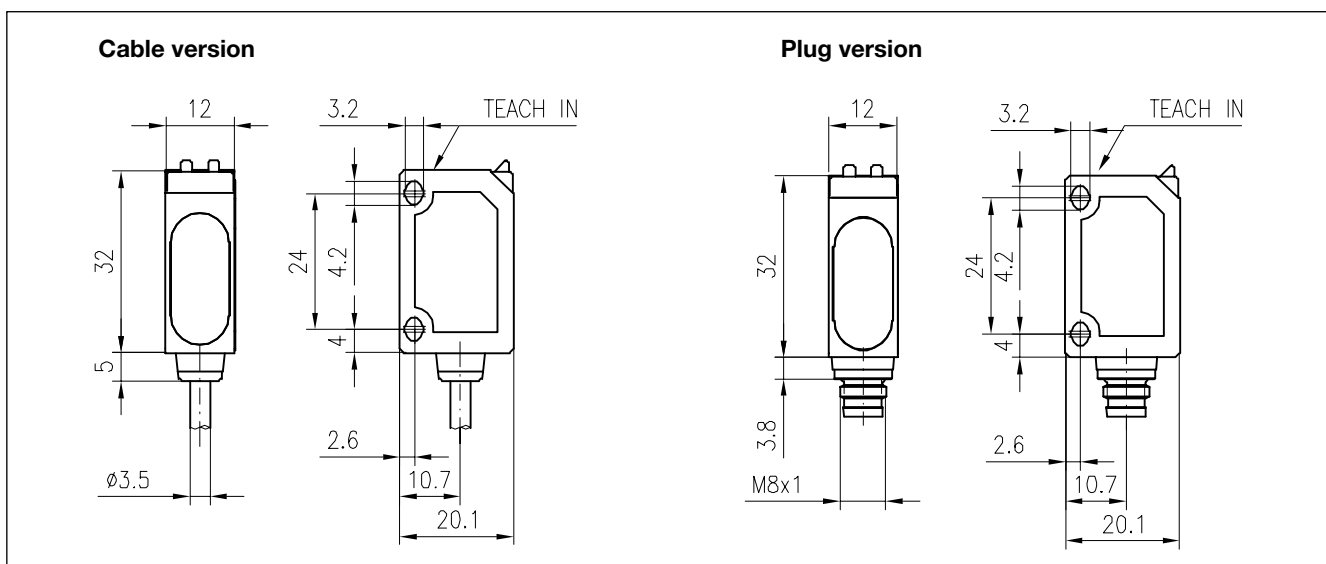

## Signal Stability Indication

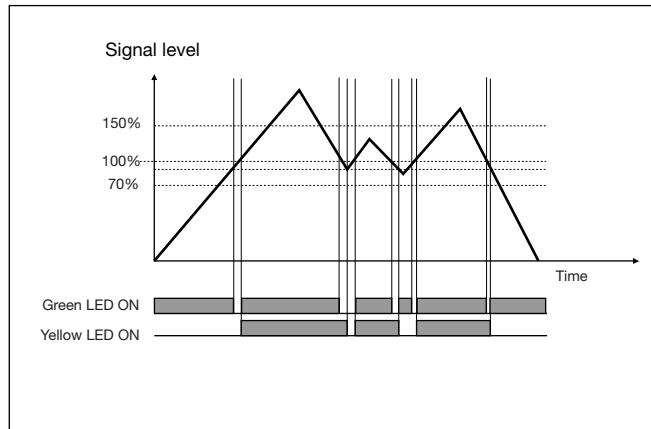

## Accessories

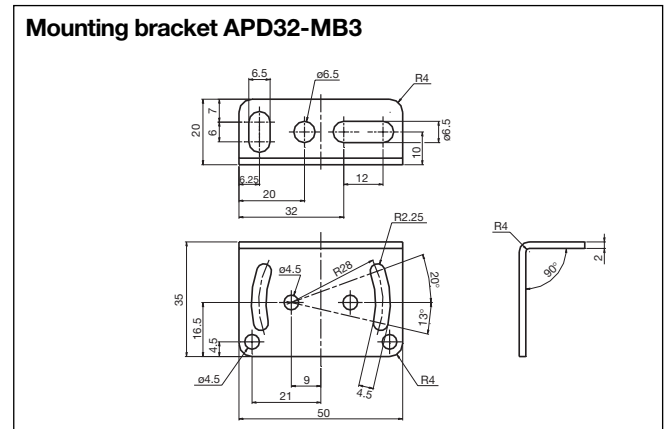

For further information refer to "Accessories"

## Installation Hints

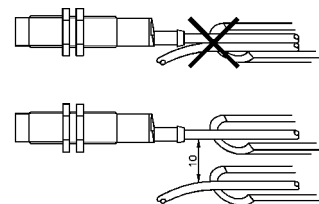
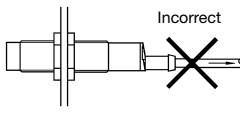
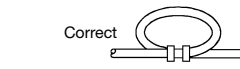
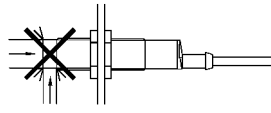
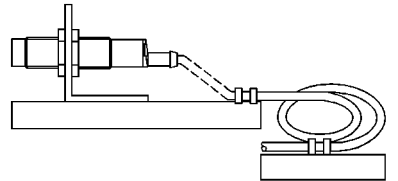
<p><i>To avoid interference from inductive voltage/current peaks, separate the prox. switch power cables from any other power cables, e.g. motor, contactor or solenoid cables</i></p> 	<p><i>Relief of cable strain</i></p> <p>Incorrect</p>  <p>Correct</p>  <p>The cable should not be pulled</p>	<p><i>Protection of the sensing face</i></p>  <p>A proximity switch should not serve as mechanical stop</p>	<p><i>Switch mounted on mobile carrier</i></p>  <p>Any repetitive flexing of the cable should be avoided</p>
---	---	--	--

## Delivery Contents

- Photoelectric switch: PD 32 CNP 25 ...
- Installation instruction
- **Packaging:** Cardboard box

## Adjustment

### Sensitivity adjustment, with static object (needed for transparent objects only)

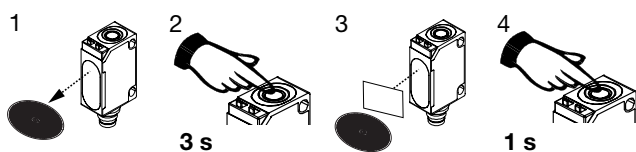

1. Line up the sensor with the reflector. Yellow LED and green LED are ON.
2. Press the button for 3 s until both LED's flash simultaneously (the first switching point is stored).
3. Place the object in the detection area.
4. Press the button for 1 s.
  - a) The green LED flashes and stays ON: the second switching point is stored, and the sensor is ready to operate.
  - b) Both LED's flash simultaneously: the sensor cannot detect the object, no switching points are stored.



### Programming of make and break switching function

1. Press the button for 13 s.  **13 s**  
Both LED's flash alternately.
2. Release the button: the green LED flashes.
3. While the green LED flashes, the output is inverted each time the button is pressed. This is indicated by the yellow LED.  
When the button is not pressed for 10 s, the current output function is stored.  
The sensor is now ready for operation.

### Default setting



1. Cover light emitter and receiver: Press the button for 3 s, until both LED's flash simultaneously.  **3 s**
2. Keep light emitter and receiver covered: Press the button for 1 s.  **1 s**  
The sensor is set to maximum sensitivity.

**NB!** The Teach Input (2 WH) will work similarly to the push button, active High.

### Adjustment to maximum sensitivity

1. Line up the sensor with the reflector. Press the button for 3 s until both LED's flash simultaneously.
2. Press the button again for 1 s (without object). The sensor is set to maximum sensitivity.

### Sensitivity adjustment, with a running process (needed for transparent objects only)

1. Line up the sensor with the reflector. Green LED is ON. At this stage the status of the yellow LED can be ignored.
2. The running process must be the only "object" within the detection area. Press the button for 3 s until both LED's flash simultaneously.  **3 s**
3. Press the button for at least the duration of one process cycle.  **1 cycle**
  - a) The green LED flashes and stays ON: both switching points have been stored, and the sensor is ready to operate.
  - b) Both LED's flash simultaneously: the sensor cannot detect the object, no switching points are stored.