

# Photoelectrics

## Retro-reflective, for transparent Objects

### Type PD32CNG05

CARLO GAVAZZI



- Miniature sensor range
- Range: 0.5 m, with reflector
- Sensitivity adjustment by Teach-In programming
- Modulated, red light 660 nm, polarized
- Supply voltage: 10 to 30 VDC
- Output: 100 mA, NPN or PNP preset
- Make and break switching function programmable
- LED for output indication, signal stability and power ON
- Protection: reverse polarity, short circuit and transients
- Cable and plug versions
- Compact housing
- Excellent EMC performance

## Product Description

The PD32CNG05 sensor family comes in a compact 12 x 32 x 20 mm reinforced PMMA/ABS-housing. The sensors are useful in applications where high-accuracy detection as well as small size is required.

The Teach-In function for adjustment of the sensitivity makes the sensors highly flexible. The output type is preset (NPN or PNP), and the output switching function is programmable (NO or NC).

## Ordering Key

**PD32CNG05PPM5T**

|                      |       |
|----------------------|-------|
| Type                 | _____ |
| Housing style        | _____ |
| Housing size         | _____ |
| Housing material     | _____ |
| Housing length       | _____ |
| Detection principle  | _____ |
| Sensing distance     | _____ |
| Output type          | _____ |
| Output configuration | _____ |
| Connection type      | _____ |
| Teach-In             | _____ |

## Type Selection

| Housing<br>W x H x D | Range<br>S <sub>n</sub> | Ordering no.<br>NPN & PNP cable<br>Make & break switching | Ordering no.<br>NPN & PNP plug<br>Make & break switching |
|----------------------|-------------------------|---|--|
| 12 x 32 x 20 mm      | 0.5 m                   | PD 32 CNG 05 NPT<br>PD 32 CNG 05 PPT                      | PD 32 CNG 05 NPM5T<br>PD 32 CNG 05 PPM5T                 |

## Specifications

|   |   |   |   |
|---|---|---|---|
| <b>Rated operating distance (S<sub>n</sub>)</b>                         | Up to 0.5 m, with reflector 51 x 51 mm              | <b>Light source</b>   | GaAIAs, LED, 660 nm                           |
| <b>Sensitivity</b>  | Adjustable by Teach-In (push button or wire)        | <b>Light type</b>   | Red, modulated                                |
| <b>Temperature drift</b>  | ≤ 1%/°C   | <b>Sensing angle</b>  | ± 2°  |
| <b>Hysteresis (H) (differential travel)</b>                             | ≤ 10%   | <b>Ambient light</b>  | 5,000 lux                                     |
| <b>Rated operational volt. (U<sub>B</sub>)</b>                          | 10 to 30 VDC (ripple included)                      | <b>Light spot</b>   | 20 x 20 mm @ 500 mm                           |
| <b>Ripple (U<sub>rpp</sub>)</b>   | ≤ 10%   | <b>Operating frequency</b>  | 1000 Hz                                       |
| <b>Output current</b><br>Continuous (I <sub>a</sub> )<br>Short-time (I) | ≤ 100 mA<br>≤ 100 mA<br>(max. load capacity 100 nF) | <b>Response time</b><br>OFF-ON (t <sub>ON</sub> )<br>ON-OFF (t <sub>OFF</sub> )                     | ≤ 0.5 ms<br>≤ 0.5 ms                          |
| <b>No load supply current (I<sub>o</sub>)</b>                           | ≤ 25 mA @ 24 VDC                                    | <b>Power ON delay (t<sub>v</sub>)</b>   | ≤ 300 ms                                      |
| <b>Minimum operational current (I<sub>m</sub>)</b>                      | 0.5 mA  | <b>Output function</b><br>NPN and PNP<br>NO/NC switching function                                   | Preset<br>Set up by button                    |
| <b>OFF-state current (I<sub>r</sub>)</b>                                | ≤ 100 μA  | <b>External Teach</b><br>Same function as button<br>Locked (disable teach button)<br>Operating mode | 10 to 30 VDC<br>0 to 2,5 VDC<br>Not connected |
| <b>Voltage drop (U<sub>d</sub>)</b>                                     | ≤ 2.4 VDC @ 100 mA                                  | <b>Indication</b><br>Output ON<br>Signal stability ON and power ON                                  | LED, yellow<br>LED, green                     |
| <b>Protection</b>   | Short-circuit, reverse polarity and transients      | <b>Environment</b><br>Installation category   | II (IEC 60664/60664A;<br>60947-1)             |



## Specifications (cont.)

|                                 |   |                         |   |
|---------------------------------|---|-------------------------|---|
| Pollution degree                | 3 (IEC 60664/60664A; 60947-1)                                   | <b>Housing material</b> | Body<br>ABS, black<br>Front material<br>PMMA, red                     |
| Degree of protection            | IP 67 (IEC 60529; 60947-1)                                      | Body                    |   |
| <b>Ambient temperature</b>      |   | <b>Connection</b>       | PUR, black, 2 m<br>4 x 0.14 mm <sup>2</sup> , Ø = 3.6 mm<br>M8, 4-pin |
| Operating                       | -20° to +60°C (-4° to +140°F)                                   | Cable                   |   |
| Storage                         | -20° to +80°C (-4° to +176°F)                                   | Plug                    |   |
| <b>Vibration</b>                | 10 to 55 Hz, 0.5 mm/7.5 g (IEC 60068-2-6)                       | <b>Weight</b>           | With cable: 40 g<br>With plug: 10 g                                   |
| <b>Shock</b>                    | 30 g / 11 ms, 3 pos, 3 neg per axis (IEC 60068-2-6, 60068-2-32) | <b>CE-marking</b>       | Yes   |
| <b>Rated insulation voltage</b> | 500 VAC (rms)   | <b>Approval</b>         | cUL   |

## Operation Diagram

tv = Power ON delay

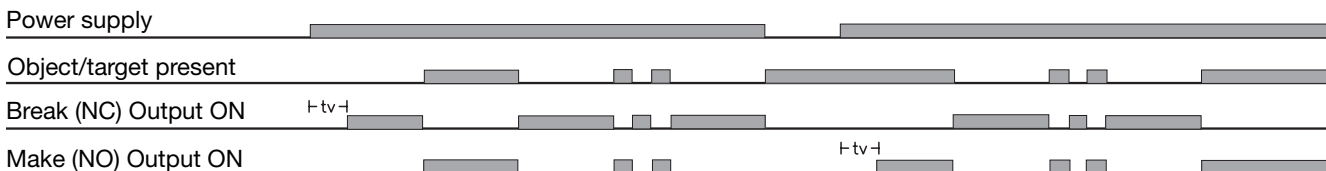

## Wiring Diagrams

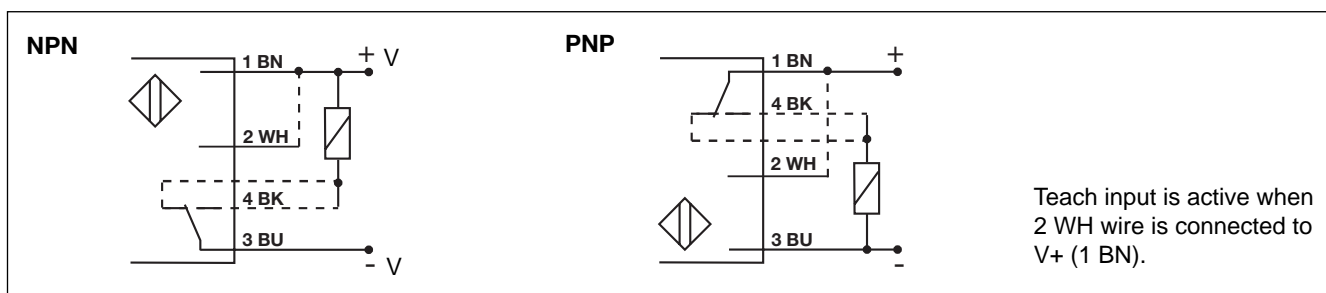

## Dimensions

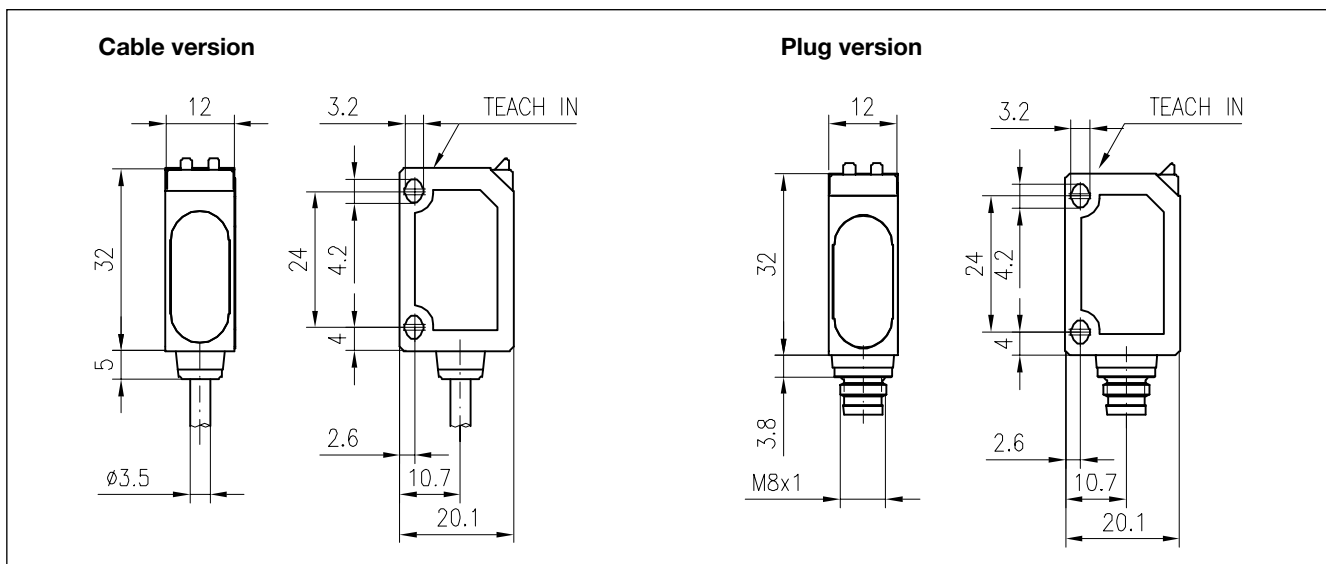

## Signal Stability Indication

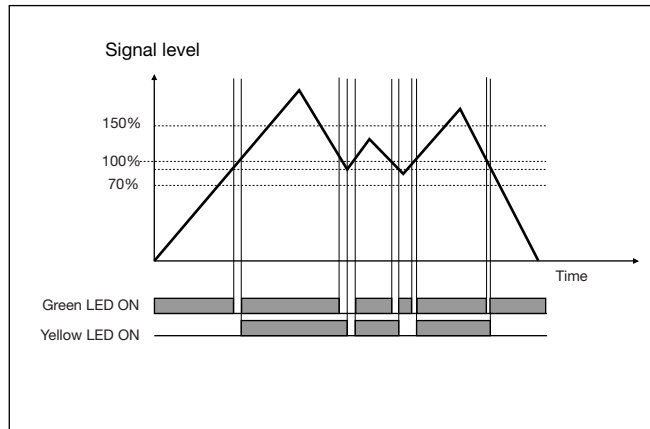

## Accessories

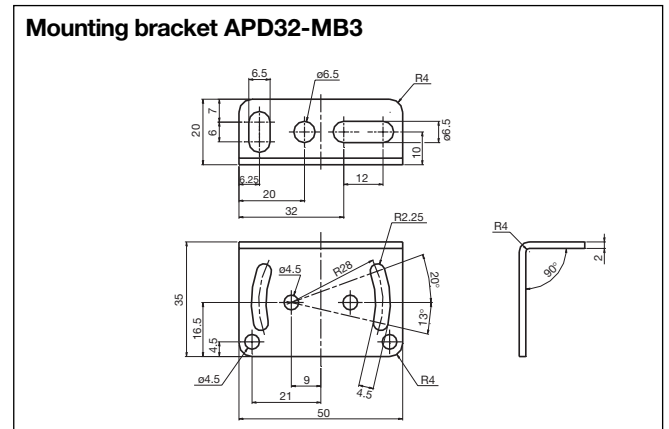

For further information refer to "Accessories"

## Installation Hints

|  |  |  |   |
|--|--|--|---|
| <p><i>To avoid interference from inductive voltage/current peaks, separate the prox. switch power cables from any other power cables, e.g. motor, contactor or solenoid cables</i></p> | <p><i>Relief of cable strain</i></p> <p>Incorrect</p> <p>Correct</p> <p>The cable should not be pulled</p> | <p><i>Protection of the sensing face</i></p> <p>A proximity switch should not serve as mechanical stop</p> | <p><i>Switch mounted on mobile carrier</i></p> <p>Any repetitive flexing of the cable should be avoided</p> |
|--|--|--|---|

## Delivery Contents

- Photoelectric switch: PD 32 CNG 05 ...
- Installation instruction
- **Packaging:** Cardboard box



## Adjustment

### Sensitivity adjustment, with static object

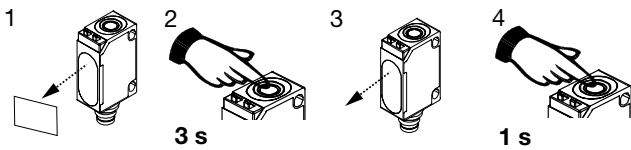
1. Line up the sensor with the reflector. Yellow LED and green LED are ON.
2. Press the button for 3 s until both LED's flash simultaneously (the first switching point is stored).
3. Press the button again for 1 s.
  - a) The green LED flashes and stays ON: the second switching point is stored, and the sensor is ready to operate.
  - b) Both LED's flash simultaneously: the sensor cannot detect the object, no switching points are stored.





### Sensitivity adjustment, with a running process

1. Line up the sensor with the reflector. Green LED is ON. At this stage the status of the yellow LED can be ignored.
2. The running process must be the only "object" within the detection area. Press the button for 3 s until both LED's flash simultaneously.
  **3 s**
3. Press the button for at least the duration of one process cycle.
  **1 cycle**
  - a) The green LED flashes and stays ON: both switching points have been stored, and the sensor is ready to operate.
  - b) Both LED's flash simultaneously: the sensor cannot detect the object, no switching points are stored.

### Programming of make and break switching function

1. Press the button for 13 s.  **13 s**  
Both LED's flash alternately.
2. Release the button: the green LED flashes.
3. While the green LED flashes, the output is inverted each time the button is pressed. This is indicated by the yellow LED.  
When the button is not pressed for 10 s, the current output function is stored.  
The sensor is now ready for operation.

### Default setting

1. Cover light emitter and receiver: Press the button for 3 s, until both LED's flash simultaneously.  **3 s**
2. Keep light emitter and receiver covered: Press the button for 1 s.  **1 s**  
The sensor is set to maximum sensitivity.

**NB!** The Teach Input (2 WH) will work similarly to the push button, active High.