

Photoelectrics

Diffuse-reflective, Background Suppression

Type PD32CNB12

CARLO GAVAZZI



- Miniature sensor range
- Range: 120 mm
- Sensitivity adjustment by Teach-In programming
- Modulated, red light 660 nm
- Supply voltage: 10 to 30 VDC
- Output: 100 mA, NPN or PNP preset
- Make and break switching function programmable
- LED for output indication, signal stability and power ON
- Protection: reverse polarity, short circuit and transients
- Cable and plug versions
- Compact housing
- Excellent EMC performance

Product Description

The PD32CNB12 sensor family comes in a compact 12 x 32 x 20 mm reinforced PMMA/ABS-housing. The sensors are useful in applications where high-accuracy detection as well as small size is required.

The Teach-In function for adjustment of the sensitivity makes the sensors highly flexible. The output type is preset (NPN or PNP), and the output switching function is programmable (NO or NC).

Ordering Key

PD32CNB12PPM5T

Type	_____
Housing style	_____
Housing size	_____
Housing material	_____
Housing length	_____
Detection principle	_____
Sensing distance	_____
Output type	_____
Output configuration	_____
Connection type	_____
Teach-In	_____

Type Selection

Housing W x H x D	Range S _n	Ordering no. NPN & PNP cable Make & break switching	Ordering no. NPN & PNP plug Make & break switching
12 x 32 x 20 mm	120 mm	PD 32 CNB 12 NPT PD 32 CNB 12 PPT	PD 32 CNB 12 NPM5T PD 32 CNB 12 PPM5T

Specifications

Rated operating distance (S_n)	Up to 120 mm, reference target Kodak test card R 27, white, 90% reflectivity, 100 x 100 mm	Protection	Short-circuit, reverse polarity and transients
Blind zone	≤ 25 mm	Light source	GaAIAs, LED, 660 nm
Sensitivity	Adjustable by Teach-In (push button or wire)	Light type	Red, modulated
Temperature drift	≤ 1%/°C	Sensing angle	± 2°
Hysteresis (H) (differential travel)	≤ 7% (grey scale displacement 90%/18%)	Ambient light	5,000 lux
Rated operational volt. (U_B)	10 to 30 VDC (ripple included)	Light spot	5 x 5 mm @ 60 mm
Ripple (U_{rpp})	≤ 10%	Operating frequency	1000 Hz
Output current		Response time	
Continuous (I _a)	≤ 100 mA	OFF-ON (t _{ON})	≤ 0.5 ms
Short-time (I)	≤ 100 mA (max. load capacity 100 nF)	ON-OFF (t _{OFF})	≤ 0.5 ms
No load supply current (I_o)	≤ 25 mA @ 24 VDC	Power ON delay (t_v)	≤ 300 ms
Minimum operational current (I_m)	0.5 mA	Output function	
OFF-state current (I_r)	≤ 100 μA	NPN and PNP	Preset
Voltage drop (U_d)	≤ 2.4 VDC @ 100 mA	NO/NC switching function	Set up by button
		External Teach	
		Same function as button	10 to 30 VDC
		Locked (disable teach button)	0 to 2.5 VDC
		Operating mode	Not connected
		Indication	
		Output ON	LED, yellow
		Power ON	LED, green

Specifications (cont.)

Environment		Rated insulation voltage	500 VAC (rms)
Installation category	II (IEC 60664/60664A; 60947-1)	Housing material	ABS, black Front material PMMA, red
Pollution degree	3 (IEC 60664/60664A; 60947-1)	Connection	
Degree of protection	IP 67 (IEC 60529; 60947-1)	Cable	PUR, black, 2 m 4 x 0.14 mm ² , Ø = 3.6 mm
Ambient temperature		Plug	M8, 4-pin
Operating	-20° to +60°C (-4° to +140°F)	Weight	With cable: 40 g With plug: 10 g
Storage	-20° to +80°C (-4° to +176°F)	CE-marking	Yes
Vibration	10 to 55 Hz, 0.5 mm/7.5 g (IEC 60068-2-6)	Approval	cUL
Shock	30 g / 11 ms, 3 pos, 3 neg per axis (IEC 60068-2-6, 60068-2-32)		

Operation Diagram

tv = Power ON delay

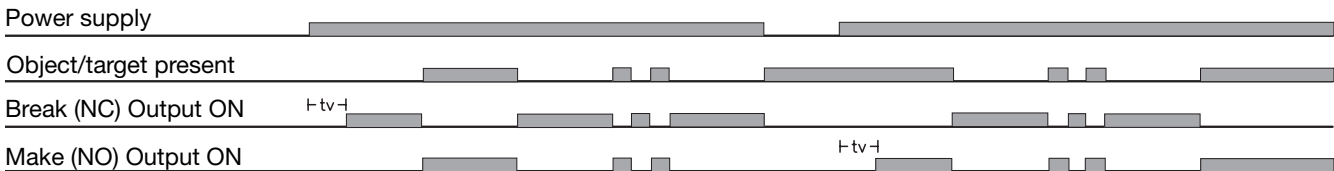

Wiring Diagrams

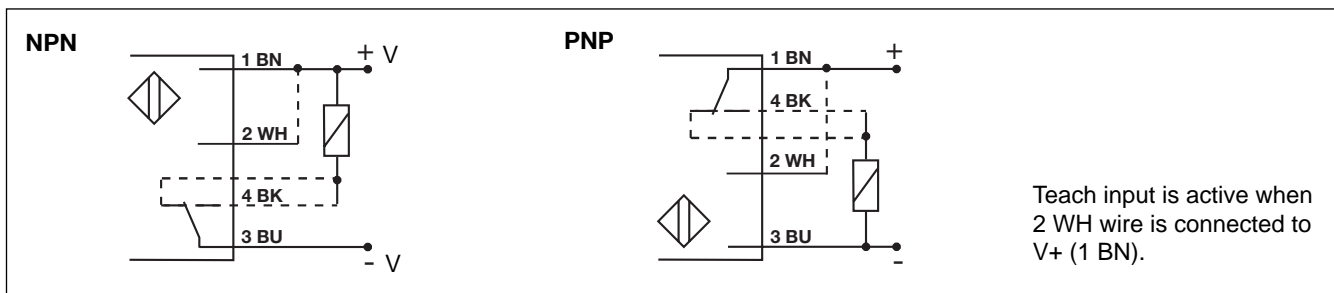

Dimensions

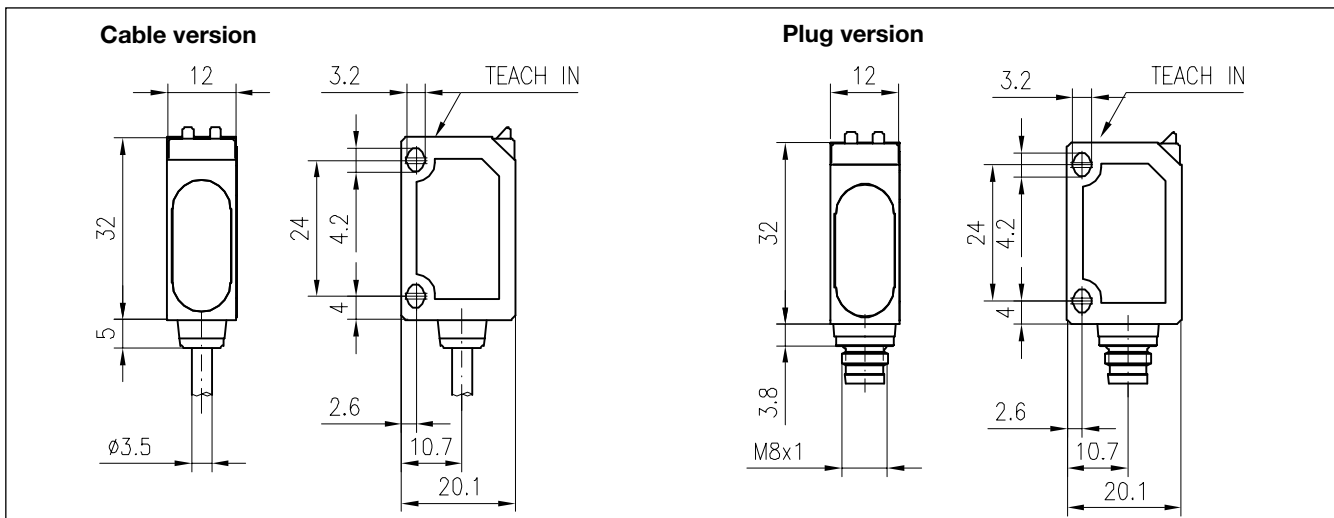

Accessories

Mounting bracket APD32-MB3

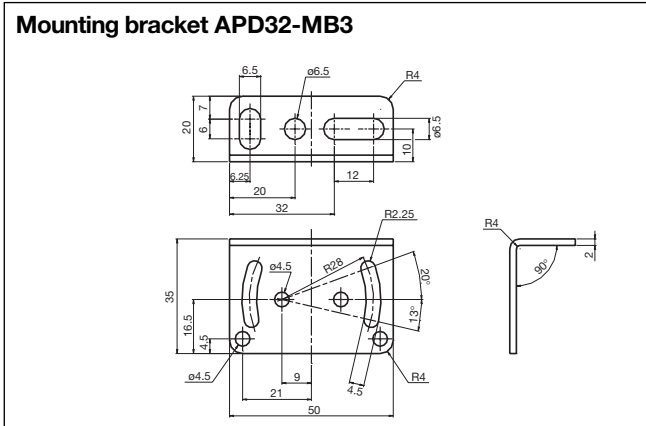

For further information refer to “Accessories”

Delivery Contents

- Photoelectric switch: PD 32 CNB 12 ...
- Installation instruction
- **Packaging:** Cardboard box

Installation Hints

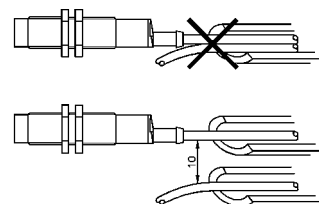
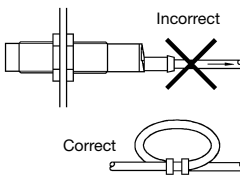
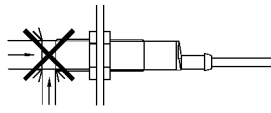
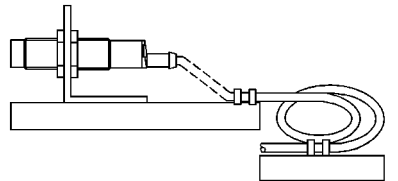
<p><i>To avoid interference from inductive voltage/current peaks, separate the prox. switch power cables from any other power cables, e.g. motor, contactor or solenoid cables</i></p> 	<p><i>Relief of cable strain</i></p>  <p>Incorrect</p> <p>Correct</p> <p>The cable should not be pulled</p>	<p><i>Protection of the sensing face</i></p>  <p>A proximity switch should not serve as mechanical stop</p>	<p><i>Switch mounted on mobile carrier</i></p>  <p>Any repetitive flexing of the cable should be avoided</p>
---	---	--	--

Adjustment

Sensitivity adjustment, with static object

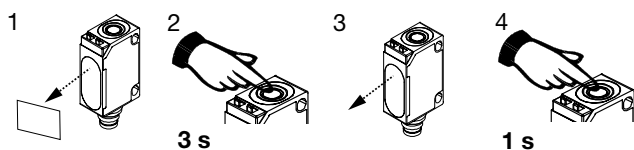

1. Line up the sensor with the object. Yellow LED and green LED are ON.
2. Press the button for 3 s until both LED's flash simultaneously (the first switching point is stored).
3. Place the object outside the detection area.
4. Press the button for 1 s.
 - a) The green LED flashes and stays ON: the second switching point is stored, and the sensor is ready to operate.
 - b) Both LED's flash simultaneously: the sensor cannot detect the object, no switching points are stored.



Programming of make and break switching function

1. Press the button for 13 s.  **13 s**
Both LED's flash alternately.
2. Release the button: the green LED flashes.
3. While the green LED flashes, the output is inverted each time the button is pressed. This is indicated by the yellow LED.
When the button is not pressed for 10 s, the current output function is stored.
The sensor is now ready for operation.

Default setting



1. No object in the detection area: Press the button for 3 s, until both LED's flash simultaneously.  **3 s**
2. No object in the detection area: Press the button for 1 s.  **1 s**
The sensor is set to maximum sensitivity.

NB! The Teach Input (2 WH) will work similarly to the push button, active High.

Sensitivity adjustment, with only one object

1. Line up the sensor with the object. Yellow LED and green LED are ON.
2. Press the button for 3 s until both LED's flash simultaneously (the first switching point is stored).
3. Leave the object in the detection area, press the button for 1 s. The green LED flashes and stays on: the second switching point is stored, and the sensor is ready to operate.

Sensitivity adjustment, with a running process

1. Line up the sensor with the object. Green LED is ON. At this stage the status of the yellow LED can be ignored.
2. The running process must be the only "object" within the detection area. Press the button for 3 s until both LED's flash simultaneously.
 **3 s**
3. Press the button for at least the duration of one process cycle.
 **1 cycle**

- a) The green LED flashes and stays ON: both switching points have been stored, and the sensor is ready to operate.
- b) Both LED's flash simultaneously: the sensor cannot detect the object, no switching points are stored.