

PD10

Seametrics

PULSE DIVIDER INSTRUCTIONS



PD10 PULSE DIVIDER INSTRUCTIONS

GENERAL INFORMATION & SPECIFICATIONS

Designed for use as a meter accessory, the PD10 divider is used primarily for pacing electronic metering pumps. Any number from one to 9999 can be set on rotary switches. Each time the divider has received the set number of pulses from the meter, it puts out one pulse to stroke the pump. The PD10 is also useful in boiler and cooling tower feed and bleed operations, and for lowering frequency output of high frequency meters. Compatible with all Seametrics flow meters, the PD10 creates a programmable pulse meter with an easily adjustable pulse rate.

The PD10 comes in two different housings: an enclosure that can be mounted near the pump, and a watertight housing for mounting on the meter.

FEATURES

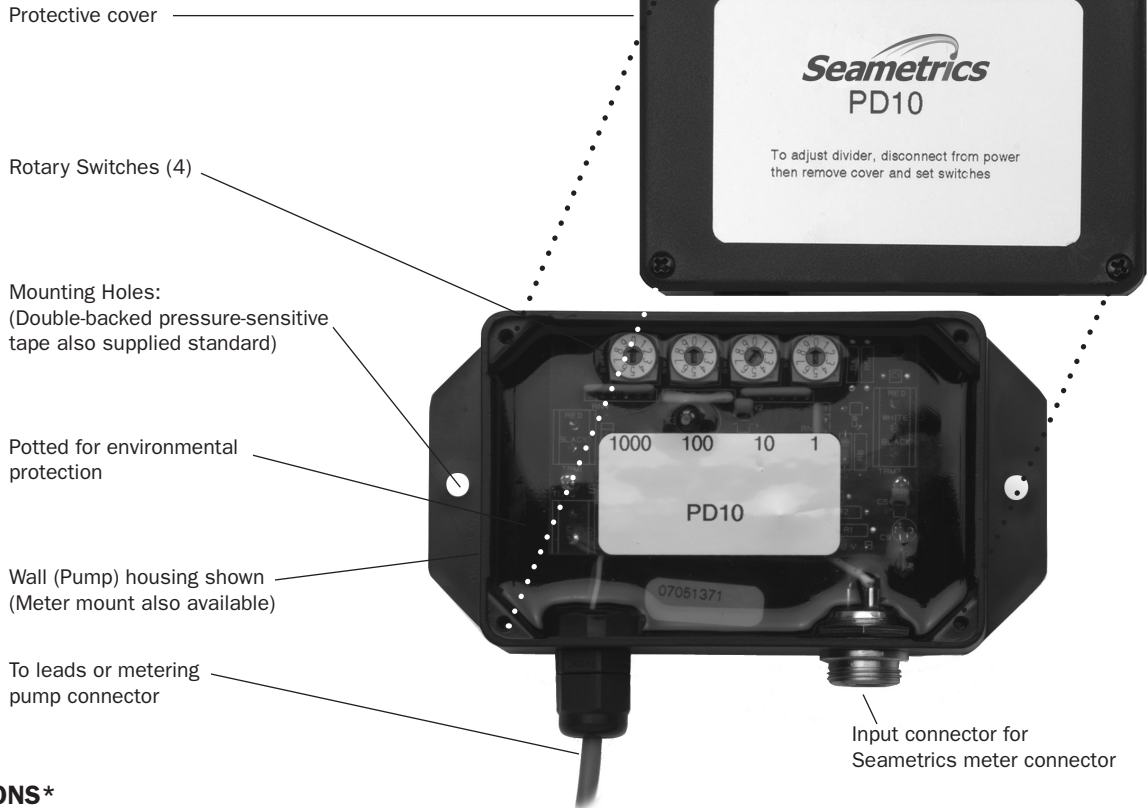

SPECIFICATIONS*

Enclosure	Wall (Pump) Mount	Epoxy-encapsulated ABS housing with cover
	Meter Mount	Cast aluminum sealed housing
Temperature		0° to 130° F (-18° to 55° C)
Divider Range		1 to 9999
Setting Mechanism		Rotary switches
Power		7 - 30 Vdc @ 4 mA
Maximum Sensor Load		20 mA
Maximum Input Frequency		350 Hz (pulses/second)
Maximum Output Frequency		8 Hz (pulses/second)
Output		Solid state relay; 0-250 V, 170 mA max AC/DC
Output Pulse Width		0.1 second
Input Connection	Wall Mount	Seametrics connector
	Meter Mount	Terminal
Output Connection	Wall Mount	Pump connector on 24 inch lead
	Meter Mount	Comes with 18 foot lead

*Specifications subject to change • Please consult our website for current data (www.seametrics.com).

INSTALLATION & CONNECTIONS

MOUNTING

The PD10M is factory-mounted on the flow sensor. The PD10W is mounted by attaching it to the metering pump with the included double-backed, pressure-sensitive tape. Alternatively, the control can be wall mounted with screws using the mounting brackets that extend out either side.



PD10M meter mounted version

POWER SOURCE

Power for the PD10 can be supplied by the metering pump if the pump has a sensor power supply. This is the case with LMI externally-paced metering pumps. Some pumps require an external power supply, available from Seametrics. LMI and Seametrics connectors are available.

CAUTION:

Power supplies 18 Vdc and higher must be regulated to prevent damage to the PD10 from voltages exceeding its 30 V allowable maximum supply voltage caused by AC line variations and light loading.

CONNECTIONS

The PD10M can be connected as shown.

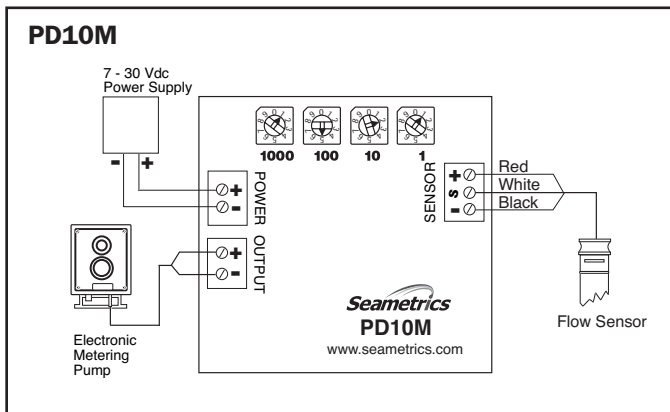

PD10W/LMI PUMP

The 24" pigtail that extends from the PD10W connects to an LMI metering pump and is connected as shown.

The input connector on the control mates with any three-pin Seametrics connector. (Meters or flow sensors to be used with a PD10W should be ordered with Seametrics connectors.)

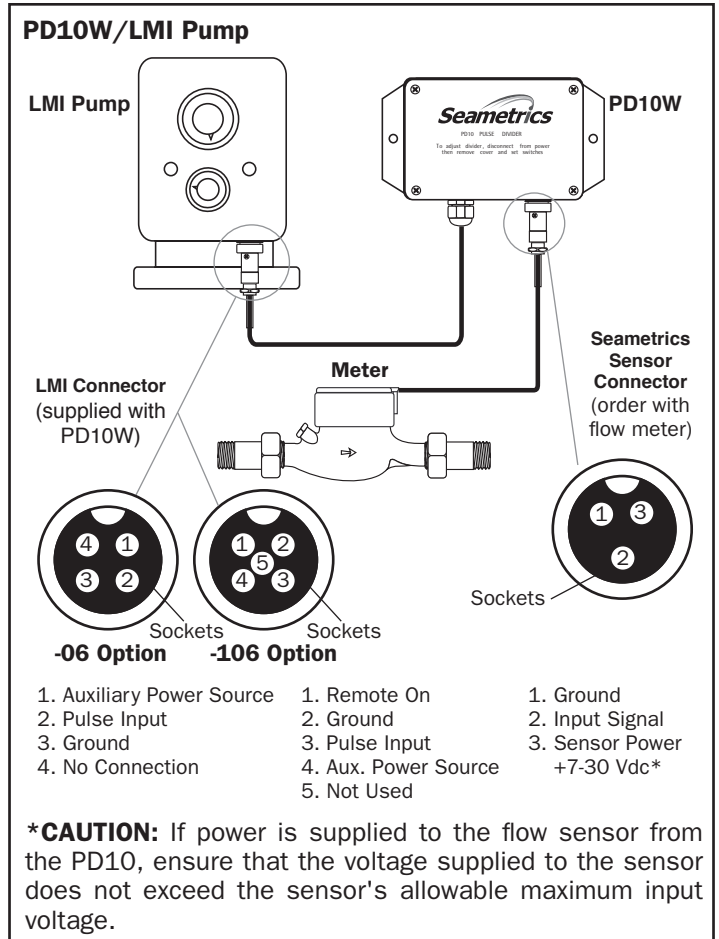

PD10W/Non-LMI Pump

If a metering pump is used that requires a connection other than the LMI connector supplied, cut the LMI connector off. Connect the PD10W to the pump using the diagram below in conjunction with the wiring diagram in the pump manual.

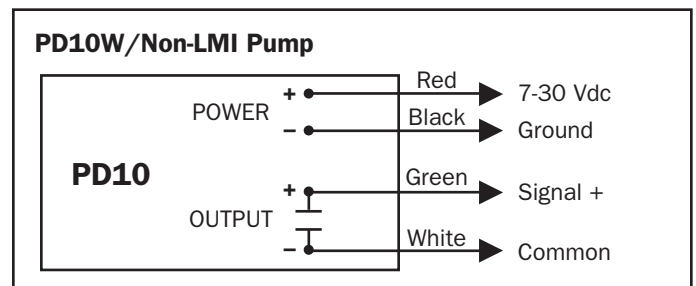

The input connector on the control mates with any three-pin Seametrics connector. (Meters or flow sensors to be used with a PD10W should be ordered with Seametrics connectors.)

SETTING

The four numbered rotary switches marked "1000", "100", "10", and "1" control the ratio of meter pulses to pump strokes. **Before setting the switches, disconnect power to the unit by removing the connector from the pump or unplugging the power adapter.**

To set any four-digit number, rotate the dials to the appropriate numbers. For example, to set 1521, set the four switches to "1", "5", "2", and "1". Any unused switches should be set to zero. For example, to set 8, position the dials to "0", "0", "0", "8". See samples below.

Setting Examples

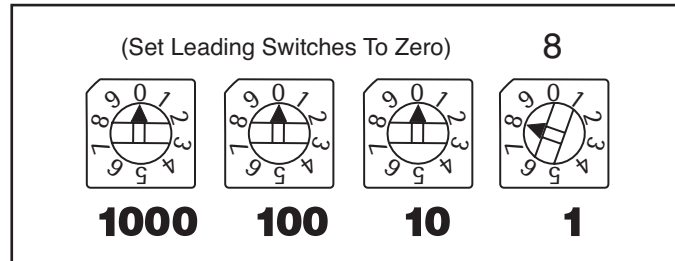
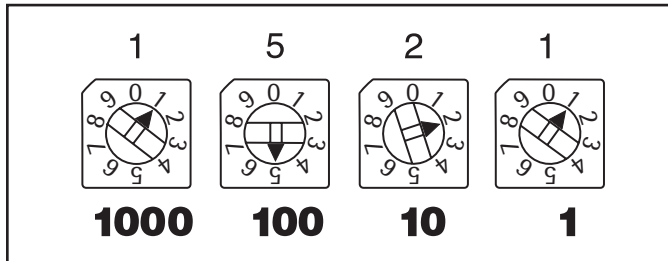

TROUBLESHOOTING

Problem	Probable Cause	Try...
Metering pump not stroking	Meter dials not turning	Check visually, then check for adequate flow
	Meter pickup not working	Remove from meter, check with a magnet
	Pump connector not plugged in all the way	Check or tighten threaded locking ring (LMI)
	Pump doesn't supply power to the PD10	Check pump manual, add power supply
	PD10 set to large number or all zeroes	Check rotary switches, esp. for leading zeroes
Pump strokes continually	Pump not set for external pacing	Check pump manual and selector switch
Pump doesn't stroke often enough or too often	PD10 set for wrong number	Review setting on this page, check rotary switches
	Multiple contacts from meter	Set PD10 to 1 contact/pump stroke (0001) and see if the pump strokes once for each magnet revolution
	Meter ordered with wrong pulse rate	Check meter model/serial tag



Seametrics Incorporated • 19026 72nd Avenue South • Kent, Washington 98032 • USA
 (P) 253.872.0284 • (F) 253.872.0285 • 1.800.975.8153 • www.seametrics.com