

PC-5 Power Adaptor

The PC-5 Power Adaptor is supplied as an optional accessory for the Amprobe DM-5 Power Quality Analyzer. The PC-5 provides power to the instrument from the circuit under test.

Power supply input terminal
(VN, V1)

Power switch

Plug (VN, V1)

Power plug

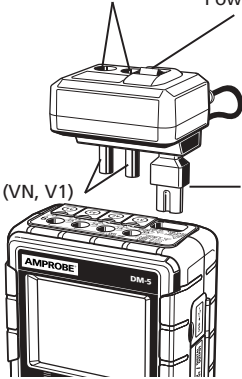

SYMBOLS

	Caution! Risk of electric shock.
	Caution! Refer to the explanation in this manual.
	The equipment is protected by double insulation or reinforced insulation.
	Fuse.
	Underwriters Laboratories (applies to Canada and U.S.A.)
	Do not dispose of this product as unsorted municipal waste. Contact a qualified recycler.

SAFETY INFORMATION

Warning!

To avoid possible electric shock or personal injury:

- If the power adaptor is used in a manner not specified by the manufacturer, protection provided by the power adaptor may be affected.
- Do not connect the power adaptor to any circuit which exceeds AC 240 V.
- Do not use the power adaptor around explosive gas, vapor, or in damp or wet environments.
- Do not use the power adaptor if it appears damaged. Inspect the power adaptor before use. Look for cracks or missing plastic. Pay particular attention to the insulation around the connectors, cord and enclosure.

- Inspect the power adaptor before and after using it to ensure that it is in good working condition.
- Power off the power adaptor before connecting to DM-5.
- Connect the power adaptor to DM-5 first, then connect to the circuit under test.
- Use supplied DM-5 test leads (TL-DM-5) only.
- Never disconnect the power adaptor when it is energized during measurement.
- Remove all cords/leads from the power adaptor before replacing the fuse.
- Replace a blown fuse with the exact replacement part only.
- Do not operate the power adaptor with covers removed or with the case open. Hazardous voltage exposure is possible.

USING PC-5

⚠ Do not connect the power adaptor to circuits which exceed AC 240 V.

Connect the PC-5 power adaptor according to below steps:

1. Ensure the power adaptor switch is OFF.
2. Connect the plugs of the power adaptor to VN and V1 terminals on DM-5 and power plug to the power connector on DM-5 respectively.
3. Connect the test leads to VN and V1 terminals of the power adaptor.
4. Connect the alligator clips of the test leads to the circuit under test.
5. Power ON the PC-5 power adaptor
6. Power ON the DM-5.

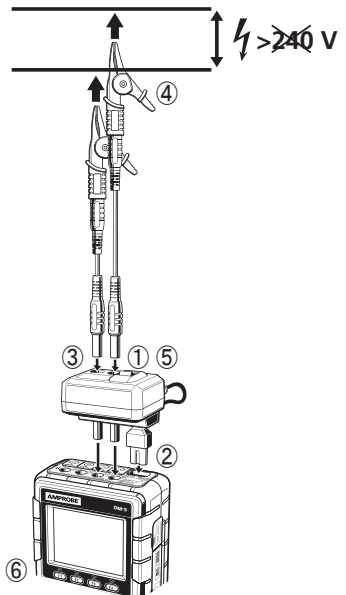

Disconnect the PC-5 power adaptor:

1. Switch the PC-5 power adaptor OFF.
2. Remove the alligator clips/test leads from the circuit under test.
3. Remove the test leads from VN and V1 terminals of the PC-5 power adaptor.
4. Remove the PC-5 power plug from the power connector on DM-5 and remove the plugs of the power adaptor from VN and V1 terminals on DM-5 respectively.

FUSE REPLACEMENT

⚠ ⚠ Warning!

Ensure the PC-5 is disconnected from energized circuit and is disconnected from DM-5.

For safety, only use the exact replacement parts.

To replace a fuse:

1. Ensure the unit is in the OFF position.
2. Loosen the screw on the fuse cover and remove the fuse cover.
3. Remove the fuse and replace with exact fuse replacement (F 0.5 A / 600 V, Ø6.3 x 32 mm) only.
4. Put the fuse cover back and tighten the screw.

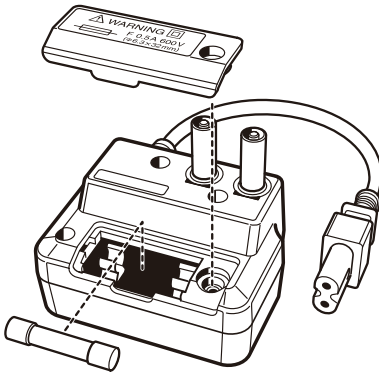

SPECIFICATIONS

Cable length	Approx. 180 mm
Max input voltage	240 Vrms
Rated rating	100 to 240 Vac, 45 to 65 Hz, 20 VA max.
Fuse rating	AC 500mA / 600V, Fast acting, Ø6.3 x 32mm
Dimension (L x W x H)	Approx. 76 x 55 x 46 mm (excludes the cord and plug)
Weight	0.12 kg (0.26 lb)
Accessory	1 x Fuse (installed), instruction manual

Limited Warranty and Limitation of Liability

Your Amprobe product will be free from defects in material and workmanship for one year from the date of purchase unless local laws require otherwise. This warranty does not cover fuses, disposable batteries or damage from accident, neglect, misuse, alteration, contamination, or abnormal conditions of operation or handling. Resellers are not authorized to extend any other warranty on the behalf of Amprobe. To obtain service during the warranty period, return the product with proof of purchase to an authorized Amprobe Service Center or to an Amprobe dealer or distributor. See Repair Section for details. THIS WARRANTY IS YOUR ONLY REMEDY. ALL OTHER WARRANTIES - WHETHER EXPRESS, IMPLIED OR STATUTORY - INCLUDING IMPLIED WARRANTIES OF FITNESS FOR A PARTICULAR PURPOSE OR MERCHANTABILITY, ARE HEREBY DISCLAIMED. MANUFACTURER SHALL NOT BE LIABLE FOR ANY SPECIAL, INDIRECT, INCIDENTAL OR CONSEQUENTIAL DAMAGES OR LOSSES, ARISING FROM ANY CAUSE OR THEORY. Since some states or countries do not allow the exclusion or limitation of an implied warranty or of incidental or consequential damages, this limitation of liability may not apply to you.

Repair

All Amprobe returned for warranty or non-warranty repair or for calibration should be accompanied by the following: your name, company's name, address, telephone number, and proof of purchase. Additionally, please include a brief description of the problem or the service requested and include the test leads with the meter. Non-warranty repair or replacement charges should be remitted in the form of a check, a money order, credit card with expiration date, or a purchase order made payable to Amprobe.

In-Warranty Repairs and Replacement – All Countries

Please read the warranty statement and check your battery before requesting repair. During the warranty period, any defective test tool can be returned to your Amprobe distributor for an exchange for the same or like product. Please check the "Where to Buy" section on www.Amprobe.com for a list of distributors near you. Additionally, in the United States and Canada, in-warranty repair and replacement units can also be sent to an Amprobe Service Center (see address below).

Non-Warranty Repairs and Replacement – US and Canada

Non-warranty repairs in the United States and Canada should be sent to an Amprobe Service Center. Call Amprobe or inquire at your point of purchase for current repair and replacement rates.

In USA
Amprobe
Everett, WA 98203
Tel: 888-993-5853
Fax: 425-446-6390

In Canada
Amprobe
Mississauga, ON L4Z 1X9
Tel: 905-890-7600
Fax: 905-890-6866

Please Recycle 

11/2015, 6006999 A ©2015 Amprobe.
All rights reserved. Printed in Japan