



MDM50

High Pressure Version

User's Manual



97478 Issue 1.3
March 2016

Please fill out the form(s) below for each instrument that has been purchased.

Use this information when contacting Michell Instruments for service purposes.

Instrument	
Code	
Serial Number	
Invoice Date	
Location of Instrument	
Tag No	

Instrument	
Code	
Serial Number	
Invoice Date	
Location of Instrument	
Tag No	

Instrument	
Code	
Serial Number	
Invoice Date	
Location of Instrument	
Tag No	



MDM50-HP

For Michell Instruments' contact information please go to
www.michell.com

© 2016 Michell Instruments

This document is the property of Michell Instruments Ltd. and may not be copied or otherwise reproduced, communicated in any way to third parties, nor stored in any Data Processing System without the express written authorization of Michell Instruments Ltd.

Contents

Safety	v
Electrical Safety	v
Pressure Safety	v
Toxic Materials	v
Repair and Maintenance	v
Calibration	v
Safety Conformity	v
Abbreviations	vi
Warnings	vi
1 INTRODUCTION	1
2 INSTALLATION	2
3 OPERATION	4
3.1 General Operation	4
3.2 Measuring Dew Points Below -40°C (-40°F).....	5
3.3 User Controls	6
3.4 4-20 mA Output Socket Wiring	7
4 GOOD MEASUREMENT PRACTICE	8
5 MAINTENANCE	12
5.1 Calibration	12
5.2 Transmitter / Battery Replacement.....	12
5.3 Filter Cartridge Replacement	14
5.4 Checking the MDM50-HP Electronics Calibration.....	14
5.5 List of Spares	14
5.6 Troubleshooting.....	15

Figures

<i>Figure 1</i>	<i>Swagelok® Fitting Instructions.....</i>	<i>3</i>
<i>Figure 2</i>	<i>User Controls</i>	<i>6</i>
<i>Figure 3</i>	<i>Jack Plug Wiring.....</i>	<i>7</i>
<i>Figure 4</i>	<i>2-Wire Connection - View Showing Rear of Connector Terminal Block.....</i>	<i>14</i>

Appendices

Appendix A	Technical Specifications.....	17
Appendix B	EU Declaration of Conformity.....	19
Appendix C	Quality, Recycling & Warranty Information.....	21
	C.1 Pressure Equipment Directive (PED) 97/23/EC	21
	C.2 Recycling Policy	21
	C.3 WEEE Compliance.....	21
	C.4 RoHS2 Compliance	22
	C.5 Warranty.....	22
	C.6 REACH Compliance	23
	C.7 Return Policy	23
	C.8 Calibration Facilities	24
	C.9 Manufacturing Quality	24
	C.10 FCC (EMC Requirements for North America)	24
Appendix D	Decontamination Declaration.....	26

Safety

The manufacturer has designed this equipment to be safe when operated using the procedures detailed in this manual. The user must not use this equipment for any other purpose than that stated. Do not apply values greater than the maximum value stated.

This manual contains operating and safety instructions, which must be followed to ensure the safe operation and to maintain the equipment in a safe condition. The safety instructions are either warnings or cautions issued to protect the user and the equipment from injury or damage. Use qualified personnel and good engineering practice for all procedures in this manual.

Electrical Safety

The instrument is designed to be completely safe when used with options and accessories supplied by the manufacturer for use with the instrument. The instrument is powered by an internally mounted rechargeable battery. The input power supply voltage limits for the battery charger supplied with the instrument are 90 to 264 V AC, 47/63 Hz.

NOTE: No other battery charger unit, other than that supplied with the instrument should be used.

NOTE: Do not allow the battery to fully discharge.

Pressure Safety

DO NOT permit pressures greater than the safe working pressure to be applied to the instrument. The specified safe working pressure is 300 barg (4350 psig). Refer to the Technical Specifications in Appendix A.

Toxic Materials

The use of hazardous materials in the construction of this instrument has been minimized. During normal operation it is not possible for the user to come into contact with any hazardous substance which might be employed in the construction of the instrument. Care should, however, be exercised during maintenance and the disposal of certain parts.

Repair and Maintenance

The instrument must be maintained either by the manufacturer or an accredited service agent. Refer to www.michell.com for details of Michell Instruments' worldwide offices contact information.

Calibration

The recommended calibration interval for the MDM50-HP is one year, unless otherwise specified by Michell Instruments Ltd. The instrument should be returned to the manufacturer, Michell Instruments, or one of their accredited service agents for re-calibration (go to www.michell.com for contact information).

Safety Conformity

This product meets the essential protection requirements of the relevant EU directives. Further details of applied standards may be found in the product specification.

Abbreviations

The following abbreviations are used in this manual:

AC	alternating current
atm	pressure unit (atmosphere)
barg	pressure unit (=100 kP or 0.987 atm) gauge
°C	degrees Celsius
°F	degrees Fahrenheit
dp	dew point
ft	feet
kg	kilogram
lb	pound
mA	milliampere
m	meter
mm	millimeter
MPa	megapascal
NI/min	normal liters per minute
psig	pound(s) per square inch (gauge)
scfh	standard cubic feet per hour
µm	micrometer
Ω	ohm
V	Volts

Warnings

The following general warnings listed below are applicable to this instrument. They are repeated in the text in the appropriate locations.



Where this hazard warning symbol appears in the following sections, it is used to indicate areas where potentially hazardous operations need to be carried out.

1 INTRODUCTION

The MDM50-HP comprises a fast responding polymer sensor fitted into a sample block with an integrated filter cartridge, and Swagelok® tube fittings on the gas inlet and outlet. The measured dew point from the sensor is shown on the clear red LED display on the front panel of the instrument.

The MDM50-HP can be supplied with either °C or °F dew-point measurement units.

A 4-20 mA analog output is provided for connection to a chart recorder, data-logger or computer system, so dew-point trends can be analyzed over time.

The electronics are housed in a rugged Peli case, providing NEMA 6 protection when the lid is closed. The case is supplied with a lifetime guarantee.

The MDM50-HP is powered by a rechargeable NiMH battery pack, giving between 12 and 16 hours of measurement time from a full charge. The instrument is delivered complete with a universal battery charger stored in the lid. It takes 16 hours to fully charge the battery pack, during which time the instrument can be switched on or off. The charger is suitable to connect power to the instrument indefinitely, but it is recommended to allow the battery pack to go through a full charge-discharge cycle at least once per month. A battery charge indicator on the instrument front panel warns when the battery is low.

MDM50-HP polymer moisture sensors are subject to a 9-point calibration, where their performance is characterized against a fundamental reference hygrometer. This process, and subsequent quality testing, ensures that all sensors behave optimally before they are used in the field. Each MDM50-HP is supplied with a calibration certificate traceable to national standards (NIST) from Mitchell Instruments' accredited laboratory.

2 INSTALLATION

On delivery, please check that all the following standard components are present in the packing box:

- MDM50-HP
- Swagelok® 6mm or 1/4" metering valve
- Swagelok® 6mm or 1/4" port adaptor
- Battery charger
- Mains lead
- 3 pole ¼" jack plug (inside lid)
- User manual
- Certificate of calibration

Before using the MDM50-HP for the first time it is recommended that the battery pack is charged for a minimum of 12 hours.

The case has a pressure relief valve on the exterior below the handle. When closed, the case is completely sealed. If the instrument is taken through altitude changes, a pressure differential will occur within the case. If this occurs: **Before opening the lid**, open the black pressure relief valve by one turn (anti-clockwise) for a few seconds. This will equalize the pressures. When the case has been opened, ensure that the pressure relief valve has been fully closed.

The supplied Swagelok® port adaptor needs to be assembled before the metering valve can be connected to the instrument.

See below:

1. Slip the nut over the machined ferrule end of the port connector

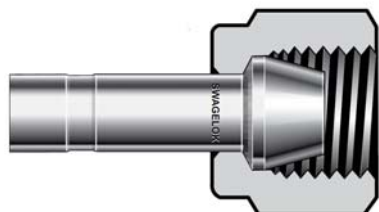

2. Insert the port connector into the end connection and finger-tighten the nut

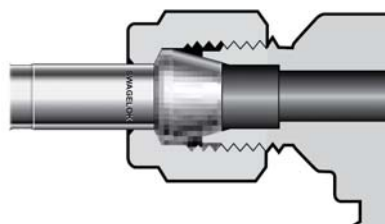

3. While holding the fitting body steady, tighten the nut one-quarter turn



Do not use the Swagelok gap inspection gauge with machined ferrule ends.

NOTE: Connect the machined ferrule end before connecting the tube adapter end

4. Insert the tube adapter until it rests firmly on the shoulder of the Swagelok® tube fitting body. Finger-tighten the nut.



5. Mark the nut at the 6 o'clock position. While holding the fitting body steady, tighten the nut 1¼ turns to the 9 o'clock position.

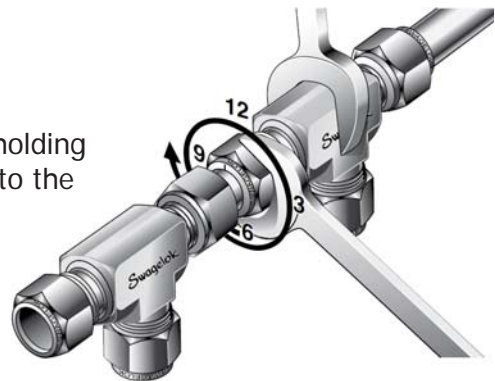

Figure 1 *Swagelok® Fitting Instructions*

3 OPERATION



Maximum operating pressure is 300 barg (4350 psig).

It is important that the gas fittings are correctly tightened, and any tubing is secure in the push fittings before use.

Failure to do so will affect the instrument's pressure rating.

3.1 General Operation

To operate the MDM50-HP, follow these instructions:

1. Ensure that both the gas fittings and the Swagelok® tube fittings are fully tightened before use.
2. For measurement at line pressure, connect the supplied metering valve to the outlet of the instrument. For measurement at atmospheric pressure, connect the metering valve to the inlet.
3. Gas under test should be restricted to flow rates between 1 and 5 NI/min (2 and 10.6 scfh) and pressures from atmospheric to 300 barg (4350 psig).
4. Connect the sample gas supply line to the instrument **Gas In** port.
5. Connect the sample gas vent line to the instrument **Gas Out** port.
6. Switch the instrument on. The display will begin to change as the sensor responds to the applied dew point.
7. Allow the gas to flow until the display shows a stable reading. Typically this would be around 15 to 30 minutes for spot checks at dew points of -40°C (-40°F) and above.
8. Switch the unit off and disconnect the sample lines.



Before disconnecting the MDM50-HP from the gas line it is essential to vent the system to atmospheric pressure, otherwise severe injury could result.

NOTE: Filters are essential for potentially dirty/contaminated gases – the fitted filter should be checked before and after use and replaced regularly - as required.

NOTE: This High Pressure version features two gas fittings with 4mm orifices that give no restriction and are engraved with a number 1. Atmospheric or line pressure measurement is achieved by changing the positioning of the metering valve as per the General Operation instructions above.

3.2 Measuring Dew Points Below -40°C (-40°F)

Due to the significantly lower levels of moisture present at dew points of this level, and the increased amount of time to dry the system out, the response times of the sensor will be significantly increased. The table below offers an approximate guide to the times taken for the instrument to stabilize at a given dew point (from a starting point of 10°Cdp (50°Fdp) ambient):

Target Dew Point		T100 Response Time (mins)
°C	°F	
-30	-22	5
-40	-40	15
-50	-58	30

3.3 User Controls

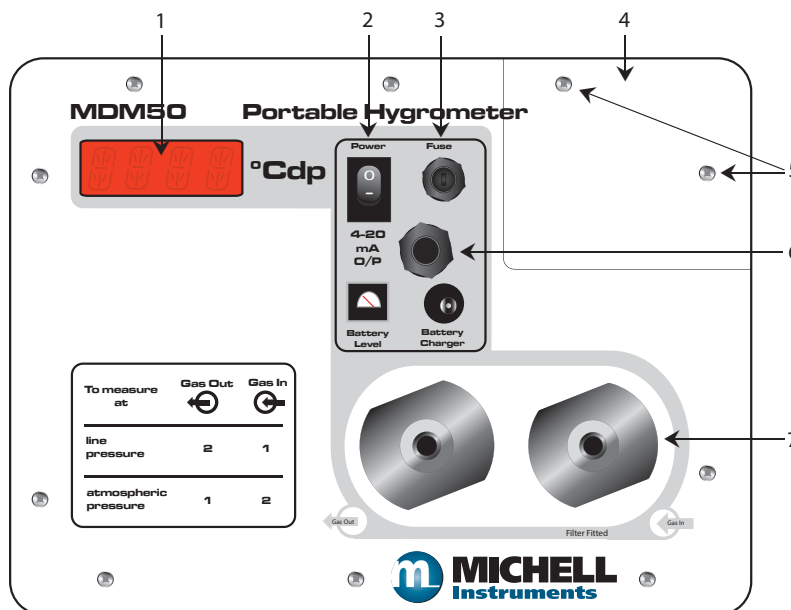

Figure 2 User Controls

1	Digital Display	Indicates the measured dew point in °C from -50 to +20 (-58 to +68°F). Under certain conditions the following error messages may be displayed: ErrL = Transmitter under range ErrH = Transmitter over range Err I = Sensor fault or transmitter disconnected
2	Power Switch	Switches the MDM50-HP ON or OFF.
3	Fuse	This 1A quick blow fuse provides protection for the display electronics in the event of a fault with the charger or battery pack. Another protection fuse is located on the display PCB.
4	NiMH Battery Pack	Located in the top right hand corner of the instrument, it can be accessed by removing two screws (5). The battery pack can be recharged using the supplied charger, via the battery-charging socket and should be recharged whenever the battery level meter is in the red region. See Section 5.6 for troubleshooting information. The battery pack will charge if the instrument is switched ON or OFF. However, the battery level meter will only indicate when the instrument is switched on.
6	Analog Output Socket	The MDM50-HP features an analog output socket that provides a linear 4-20 mA current loop, scaled to -60 to +60°C (-76 to +140°F) dew point. This allowed the instrument to be connected to a chart recorder, data logger or PC to enable dew-point trends to be analyzed over time.
7	Gas Fittings	The MDM50-HP can be used for measurements at line pressure (up to 300 barg (4350 psig)) or atmospheric pressure. Swagelok® tube fittings are supplied for use with 6mm or ¼" OD stainless steel tube. There is a 32mm particulate filter (99.5% removal of 0.1 micron particles) fitted as standard under the Gas In port position.

3.4 4-20 mA Output Socket Wiring

The MDM50-HP provides a linear 4-20 mA output scaled from -60 to +60°C (-76 to +140°F).

The socket accepts a 3 pole ¼" jack plug (supplied) and should be wired as shown below:

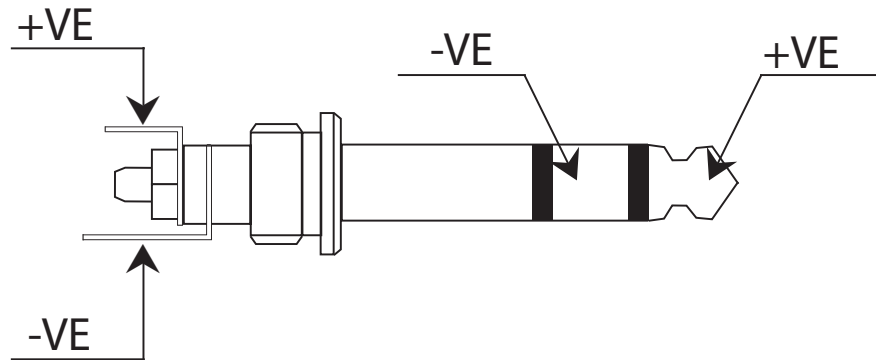
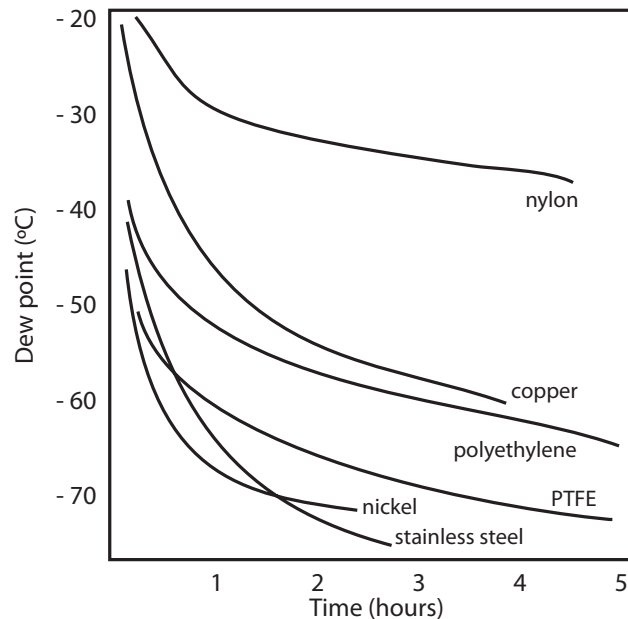

Figure 3 *Jack Plug Wiring*

4 GOOD MEASUREMENT PRACTICE

Measurement of moisture content is a complex subject, but does not need to be difficult. This section aims to explain the common mistakes made in measurement situations, the causes of the problem, and how to avoid them. Mistakes and bad practices can cause the measurement to vary from the expectation; therefore a good sampling technique is crucial for accurate and reliable results.

Transpiration and Sampling Materials



All materials are permeable to water vapor, as the water molecule is extremely small compared to the structure of solids, even when compared to the crystalline structure of metals. The graph to the right shows the dew point inside tubing of different materials when purged with very dry gas, where the exterior of the tubing is in the ambient environment.

Many materials contain moisture as part of their structure, particularly organic materials (natural or synthetic), salts (or anything which contains them) and anything which has small pores. It is important to ensure that the materials used are suitable for the application.

If the partial water vapor pressure exerted on the outside of a compressed air line is higher than on the inside, the atmospheric water vapor will naturally push through the porous medium causing water to migrate into the pressurized air line. This effect is called transpiration.

Adsorption and Desorption

Adsorption is the adhesion of atoms, ions, or molecules from a gas, liquid, or dissolved solid to the surface of a material, creating a film. The rate of adsorption is increased at higher pressures and lower temperatures.

Desorption is the release of a substance from or through the surface of a material. In constant environmental conditions, an adsorbed substance will remain on a surface almost indefinitely. However, as the temperature rises, so does the likelihood of desorption occurring.

In practical terms, as the temperature of the environment fluctuates, water molecules are adsorbed and desorbed from the internal surfaces of the sample tubing, causing small fluctuations in the measured dew point.

Sample Tubing Length

The sample point should always be as close to the critical measurement point as possible, in order to obtain a truly representative measurement. The length of the sample line to the instrument should be as short as possible. Interconnection points and valves trap moisture, so using the simplest sampling arrangement possible will reduce the time it takes for the sample system to dry out when purged with dry gas.

Over a long tubing run, water will inevitably migrate into any line, and the effects of adsorption and desorption will become more apparent. It is clear from the graph shown above that the best materials to resist transpiration are stainless steel and PTFE.

Trapped Moisture

Dead volumes (areas which are not in a direct flow path) in sample lines, hold onto water molecules which are slowly released into the passing gas; this results in increased purge and response times, and wetter than expected readings. Hygroscopic materials in filters, valves (e.g. rubber from pressure regulators) or any other parts of the system can also trap moisture.

Sample Conditioning

Sample conditioning is often necessary to avoid exposure of sensitive measuring components to liquids and other contaminants which may cause damage or affect the accuracy over time, depending on the measurement technology.

Particulate filters are used for removing dirt, rust, scale and any other solids that may be in a sample stream. For protection against liquids, a coalescing filter should be used. The membrane filter is a more expensive but highly effective alternative to a coalescing filter. It provides protection from liquid droplets, and can even stop flow to the analyzer completely when a large slug of liquid is encountered.

Condensation and Leaks

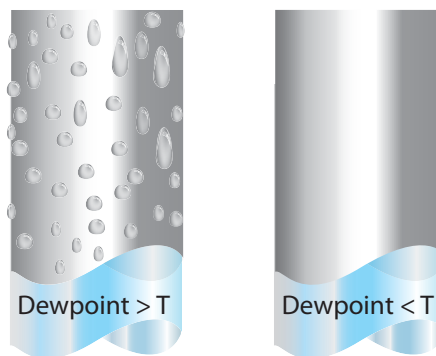

Maintaining the temperature of the sample system tubing above the dew point of the sample is vital to prevent condensation. Any condensation invalidates the sampling process as it changes the water vapor content of the gas being measured. Condensed liquid can alter the humidity elsewhere by dripping or running to other locations where it may re-evaporate.

The integrity of all connections is also an important consideration, especially when sampling low dew points at an elevated pressure. If a small leak occurs in a high pressure line, gas will leak out but vortices at the leak point and a negative vapor pressure differential will also allow water vapor to contaminate the flow.

Flow Rates

Theoretically flow rate has no direct effect on the measured moisture content, but in practice it can have unanticipated effects on response speed and accuracy. The optimal flow rate varies depending on the measurement technology, and can always be found in the instrument or transmitter manual.

An inadequate flow rate can:

- Accentuate adsorption and desorption effects on the gas passing through the sampling system.
- Allow pockets of wet gas to remain undisturbed in a complex sampling system, which will then gradually be released into the sample flow.
- Increase the chance of contamination from back diffusion: ambient air that is wetter than the sample can flow from the exhaust back into the system. A longer exhaust (sometimes called a pigtail) can also help alleviate this problem.
- Slow the response of the sensor to changes in moisture content.

An excessively high flow rate can:

- Introduce back pressure, causing slower response times and unpredictable effects on equipment such as humidity generators.
- Result in a reduction in heating capabilities of the sensor tile during the initialization period. This is most apparent with gases that have a high thermal conductivity such as hydrogen and helium.

Which Gases to Measure?

The MDM50-HP is suitable for measurement of the moisture content of a wide variety of gases. In general, if the gas (in conjunction with water vapor) is not corrosive to ceramics or base metals then it will be suitable for measurement.



POSSIBLE INJURY! The tubing, valves and other apparatus attached to this instrument must be adequate for the maximum pressure which will be applied, otherwise physical injury to the operator or bystander is possible.



Before disconnecting the MDM50-HP from the gas line it is essential to vent the system to atmospheric pressure, otherwise severe injury could result.

5 MAINTENANCE

Routine maintenance of the MDM50-HP is confined to regular re-calibration of the internal, removable SF72 transmitter and replacement of the filter cartridge.

5.1 Calibration

The calibration of the internal transmitter is traceable to national standards. For this reason it should only be calibrated in an accredited, e.g. UK *United Kingdom Accreditation Service (UKAS)* or US *National Institute of Standards and Technology (NIST)* standards laboratory. If these facilities do not exist it is recommended that the transmitter is returned to the manufacturer, Michell Instruments, or an approved agent. A calibration certificate bearing a seven-point calibration is issued with each transmitter.

In most applications, annual re-calibration ensures that the stated accuracy of the SF72 transmitter is maintained.

5.2 Transmitter / Battery Replacement

To remove the transmitter, or battery pack:

1. Ensure instrument is switched off and that the battery charger, current output and any sampling components are also disconnected.
2. Remove and retain the 10 cross-head screws from the top plate.
3. Lift the small battery pack cover in the top right corner of the instrument. A small flat bladed screwdriver may be required to gently pry the edges of the cover if it has become stuck to the waterproof seal underneath. Removing this cover first will make it easier to lift the entire top panel out of the instrument.
4. Lift the top plate of the instrument out of the case. Disconnect the battery pack before removing the top plate completely to prevent it from straining on the attached cable. If only replacing the battery pack, do not follow the next two steps.
5. Undo the screw from the centre of the transmitter connecting plug and pull off the connector.
6. Unscrew the transmitter from the block.

Fitting the replacement is simply a reversal of the above procedure. When fitting a new transmitter it may be necessary to change the alignment of the GDSN connector (see next page).

If the front panel prevents the connector from fitting onto the transmitter, follow the instructions below:

- Completely unscrew the cable gland on the GDSN connector to release the cable tension.

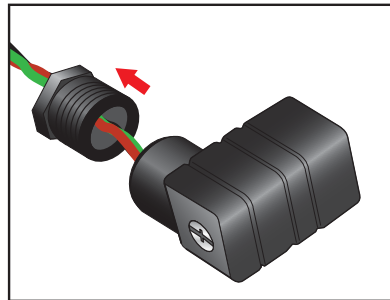

- Remove the locking screw from the back of the connector (retaining the metal O-ring).

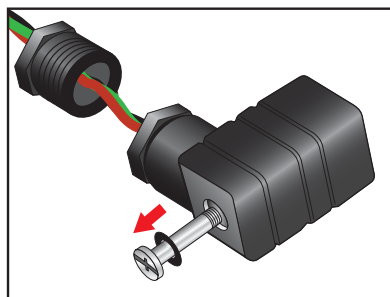

- Remove the connector block using a small screwdriver.

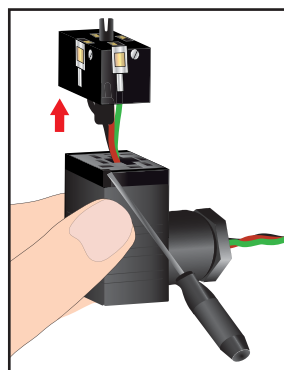

- Rotate the connector block and push it back into the connector housing. Take care not to trap any wires against the hole for the locking screw.

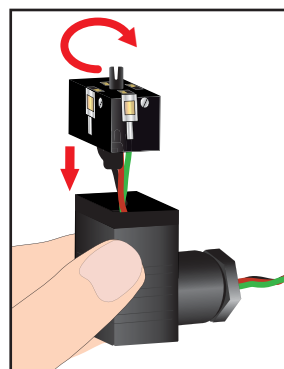

- Replace the locking screw and cable gland.

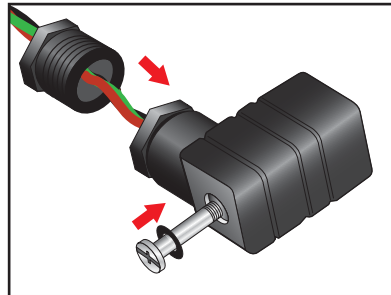

5.3 Filter Cartridge Replacement

Unscrew the gas inlet fitting to reveal the filter, which can then simply be removed for checking or replacement.

5.4 Checking the MDM50-HP Electronics Calibration

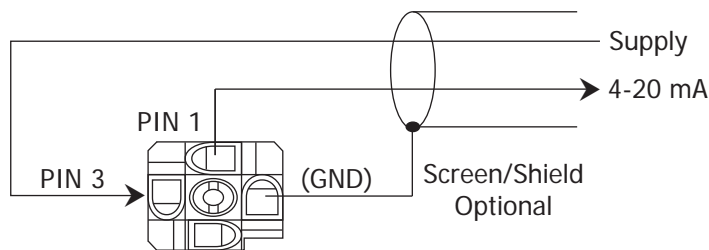

Figure 4 2-Wire Connection - View Showing Rear of Connector Terminal Block

To verify if the display electronics are within calibration a 4-20mA current source can be connected in place of the transmitter.

At 4 mA the display should show $-60.0^{\circ}\text{Cdp} \pm 0.5^{\circ}\text{C}$ ($-76.0^{\circ}\text{Fdp} \pm 0.9^{\circ}\text{F}$)

At 20 mA the display should show $+60.0^{\circ}\text{Cdp} \pm 0.5^{\circ}\text{C}$ ($+140.0^{\circ}\text{Fdp} \pm 0.9^{\circ}\text{F}$)

If the displayed values are outside of this range, please contact Michell Instruments' Service Department.

5.5 List of Spares

P/N	Description
SSF-PF-10PK	Pack of 10 particulate filter cartridges
MDM50-BAT	Replacement battery pack
MDM50-CHR	Replacement battery charger

5.6 Troubleshooting

Symptom	Cause	Actions
Display shows "ErrI"	Transmitter disconnected or sensor element / sensor thermistor fault. NOTE: This error is normally displayed during the first few seconds while the instrument is starting up.	Check transmitter cable is securely connected inside instrument. Check instrument electronics with 4-20mA source. Exchange transmitter.
Display shows "ErrL"	Transmitter reading under-range. Transmitter current signal < 4mA. Transmitter element open circuit.	Check instrument electronics with 4-20mA source. Exchange transmitter.
Display shows "ErrH"	Transmitter reading over-range. Transmitter current signal > 20mA. Sensor element short circuit.	Sensor may have been exposed to saturation conditions or liquid contamination. Check that filter and sensor guard are clean and dry. If liquid water has contacted sensor, or sensor block, then disassemble and dry thoroughly. After drying, it is recommend to purge assembled instrument with very dry (-75°Cdp (-103°Fdp) / 1ppm _v moisture) air for 12 to 24 hours. Exposure to other contaminants can cause lasting damage and may require transmitter to be exchanged. Check instrument electronics with 4-20mA source.
Display flickers on and off	Battery voltage low.	Connect charger.
Display off but battery meter full	Battery voltage low.	Connect charger.

Appendix A

Technical Specifications

Appendix A Technical Specifications

Performance	
Measurement Technology	Polymer Capacitive
Measurement Range	-50 to +20°Cdp (-58 to +68°Fdp)
Accuracy	±2°Cdp (±3.6°Fdp)
Run time	12 - 16 hours
Charge time	16 hours for maximum charge
Flow Rate	1 to 5 NI/min (2.1 to 10.5 scfh)
Electrical Input/Output	
Output	4-20 mA current maximum load resistance 400 Ω
Power Supply	Rechargeable NiMH battery pack, charger included
Operating Conditions	
Operating Temperature	-20 to +50°C (-4 to +122°F)
Storage Temperature	-40 to +75°C (-40 to +167°F)
Operating Pressure	Up to 30 MPa (300 barg (4350 psig))
Mechanical Specifications	
Display	Flush mounted 3.5 digit red LED
Case	Yellow propylene with charger, sample tubing and output connector stored in the lid
Weight	4kg (8.8lbs) total weight
Enclosure Rating Case Closed	NEMA Type 6
Sample Connections	Optional 6mm or 1/4" Swagelok® tube fittings
Sample Block	Stainless steel, fully self-contained sample system using a standard drop-in cartridge
Filter Cartridge	Removes 99.5% of particles ≥ 0.3 μm supplied with cartridge installed. Spare cartridges are available (part no: SSF-PF-10PK)

Appendix B

EU Declaration of Conformity

Appendix B EU Declaration of Conformity

EU Declaration of Conformity



Manufacturer: **Michell Instruments Limited**
48 Lancaster Way Business Park
Ely, Cambridgeshire
CB6 3NW. UK.



On behalf of the above named company, I declare that, on the date that the equipment accompanied by this declaration is placed on the market, the equipment conforms with all technical and regulatory requirements of the listed directives.

MDM50 Portable Hygrometer

and complies with all the essential requirements of the EU directives listed below.

2004/108/EC EMC Directive
 and (effective date 20th April 2016)
2014/30/EU EMC Directive

(effective date 22nd July 2017)

2011/65/EU Restriction of Hazardous Substances Directive (RoHS2)

RoHS2 EU Directive 2011/65/EU (Article 3, [24]) states, "*industrial monitoring and control instruments means monitoring and control instruments designed exclusively for industrial or professional use*". (mandatory compliance effective date 22nd July 2017).

and has been designed to be in conformance with the relevant sections of the following standards or other normative documents.

EN60529 Degrees of Protection Provided by Enclosures. Ingress Rating equivalent to IP66

EN61326-1:2013 Electrical equipment for measurement, control and laboratory use - EMC requirements. Class A (emissions) and Industrial Locations (immunity).

A handwritten signature in black ink, appearing to read 'A. Stokes', written over a horizontal line.

Andrew M.V. Stokes, Technical Director

April 2016

Appendix C

Quality, Recycling & Warranty Information

Appendix C Quality, Recycling & Warranty Information

C.1 Pressure Equipment Directive (PED) 97/23/EC

The above Directive has been implemented in United Kingdom Law by the Pressure Equipment Regulations 1999.

The Regulations require that all pressure equipment and assemblies within the scope of the Pressure Equipment Directive must be safe when placed on the market or put into service.

Michell Instruments' products have been assessed and, as referenced against the Classification Charts detailed in Annex II of the Directive, do not fall into the requirements for CE marking compliance with the Pressure Equipment Directive.

Article 3, paragraph 3 states that any product containing a pressurized fluid that does not qualify for compliance should, nevertheless, be constructed with Sound Engineering Practice (SEP).

Michell Instruments attests here that its products have been designed, manufactured & tested to assure safe operation, and in accordance with Sound Engineering Practices.

C.2 Recycling Policy



Michell Instruments is concerned with the protection of the environment. It is our commitment to reduce and eliminate from our operations, wherever possible, the use of substances which may be harmful to the environment. Similarly, we are increasingly using recyclable and/or recycled material in our business and products wherever it is practical to do so.

To protect natural resources and to promote material reuse, please separate batteries from other types of waste and recycle responsibly. If batteries are not properly disposed of, these substances can cause harm to human health and the environment.

The product that you have purchased may contain recyclable and/or recycled parts and we will be happy to provide you with information on these components if required. For further information please see the following sections.

C.3 WEEE Compliance

Directive 2012/19/EU 4 July 2012 on Waste Electronic and Electrical Equipment (WEEE)

The Waste Electronic and Electrical Equipment (WEEE) Directive places rules upon European manufacturers of electrical and electronic equipment. The directives' aim is to reduce the impact that electronic devices have on the environment.

Michell Instruments is in full compliance with the WEEE Directive and is registered with an approved recycler (Registration No. WEE/JB0235YW) and treats the requirement of the directive and the protection of the environment with the utmost importance. All Michell Instruments' products are appropriately marked indicating their requirement for recycling.

It may be required to return certain instruments for treatment at the end of their working life.

Feb 2013

C.4 RoHS2 Compliance

Directive 2011/65/EU of the European Parliament and of the Council of 8 June 2011

The Restriction of Hazardous Substances (RoHS) Directive places rules upon European manufacturers of electrical and electronic equipment. The directives' aim is to reduce the impact that electronic devices have on the environment.

According to the EC Directive 2002/95/EC, Michell Instruments' products qualify as Category 9, Control and Monitoring Equipment. Under the 2002/95/EC Directive, Category 9 products are exempt from compliance with the Directive.

However, the careful design of all Michell Instruments' products takes into consideration the requirements of the Directive and, wherever possible, compliance is achieved. All future products will be developed entirely using compliant materials. Furthermore, Michell Instruments is taking active steps to remove non-compliant materials and components from existing products wherever these may occur. Presently, none of the non-compliant materials are known to occur in Michell Instruments' products.

The new Directive 2011/65/EU (RoHS2) entered into force on 21 July 2011 and required all Member States to transpose the provisions into their respective national laws by 2 January 2013.

Under the provisions of the RoHS2 EU Directive 2011/65/EU (Article 3, [24]) defines 'Control and Monitoring Equipment' specifically as 'monitoring and control instruments designed exclusively for industrial or professional use'.

RoHS2 EU Directive 2011/65/EU states the closing date for compliance of any Control and Monitoring Equipment product sold into the EU market place as 22nd July 2017.

However, the careful design policy of all Michell Instruments' products continues to attain compliance in the shortest practical timescales and strives to ensure that less than 0.1% of total mass per product, of all non-compliant materials, appear within them. Michell Instruments continues to monitor suppliers and material sources to ensure that compliance of goods provided is maintained.

January 2013

C.5 Warranty

Unless otherwise agreed, the Supplier warrants that, as from the date of delivery for a period of 12 months, the goods and all their component parts, where applicable, are free from any defects in design, workmanship, construction or materials.

The Supplier warrants that the services undertaken shall be performed using reasonable skill and care, and be of a quality conforming to generally accepted industry standards and practices.

Except as expressly stated, all warranties whether express or implied, by operation of law or otherwise, are hereby excluded in relation to the goods and services to be provided by the Supplier.

All warranty services are provided on a return to base basis. Any transportation costs for the return of a warranty claim shall reside with the Customer.

C.6 REACH Compliance

Regulation (EC) No. 1907/2006

Registration, Evaluation, Authorisation and Restriction of Chemicals (REACH)

Michell Instruments is a manufacturer of moisture measurement and gas analysis instrumentation and is a 'downstream' user of chemicals, as described by the EU Council Directive 76/769/EEC. The products we supply are not raw chemical products (goods).

Under normal and reasonably foreseeable circumstances of application, the goods supplied to you shall not contain or release any prohibited chemicals. No listed SVHC (Substances of Very High Concern) appear within products manufactured by Michell Instruments. Therefore the 0.1% mass per product, or total usage of 1 tonne/year, will never be exceeded. For these reasons we are neither required by obligation for registration nor for the creation of material safety data sheets (MSDS) for our products.

Our continued review of the SVHC Candidate List and latest additions is to ensure we remain compliant.

Michell Instruments maintains a hazardous material register in which MSDS data sheets are collated, and we will check that our suppliers will comply to REACH requirements for all materials and substances we use in the processes of our manufacturing.

In the unlikely event that any chemicals of concern appear in our products in quantities greater than 0.1% of total mass per product we will immediately inform you by correspondence according to the REACH Article 33 requirements. Our current appraisal is, however, that we do not expect or foresee such an incidence.

January 2013

C.7 Return Policy

If a Michell Instruments' product malfunctions within the warranty period, the following procedure must be completed:

1. Notify a Michell Instruments' distributor, giving full details of the problem, the model variant and the serial number of the product.
2. If the nature of the problem indicates the need for factory service then the instrument should be returned to Michell Instruments, carriage prepaid, preferably in the original packaging, with a full description of the fault and the customer contact information.
3. Upon receipt, Michell Instruments will evaluate the product to determine the cause of the malfunction. Then, one of the following courses of action will be taken:
 - If the fault is covered under the terms of the warranty, the instrument will be repaired at no cost to the owner and returned.
 - If Michell Instruments determines that the fault is not covered under the terms of the warranty, or if the warranty has expired, an estimate for the cost of the repairs, at standard rates, will be provided. Upon receipt of the owner's approval to proceed, the product will be repaired and returned.

C.8 Calibration Facilities

Michell Instruments' calibration facilities are among the most sophisticated in the world and have been recognized for their excellence.

Traceability to the National Physical Laboratory (NPL) UK is achieved through our UKAS Accreditation (Number 0179). This covers dew point over the range -90 to +90°C (-130 to +194°F) and also Relative Humidity.

Dew-point calibrations are also traceable to the National Institute for Standards & Technology (NIST) USA over the range -75 to +20°C (-103 to +68°F).

NOTE: Standard traceable calibration certificates for instruments and sensors are not issued under our UKAS accreditation.

C.9 Manufacturing Quality

Michell Instruments is registered with the British Standards Institute for Quality Assurance to:

BS EN ISO 9001: 2008

Rigorous procedures are performed at every stage of production to ensure that the materials of construction, manufacturing, calibration and final test procedures meet the requirements laid down by our BSI approved Quality System.

Please contact Michell Instruments (www.michell.com) if the product does not arrive in perfect working order.

C.10 FCC (EMC Requirements for North America)

This device complies with part 15 of the FCC Rules. Operation is subject to the following two conditions:

1. This device may not cause harmful interference.
2. This device must accept any interference, including interference that may cause undesired operation.

This equipment has been tested and found to comply with the limits for a Class A digital device, pursuant to part 15 of the FCC Rules. These limits are designed to provide reasonable protection against harmful interference when the equipment is operated in a commercial environment. This equipment generates, uses, and can radiate radio frequency energy and, if not installed and used in accordance with the user manual, may cause harmful interference to radio communications. Operation of this equipment in a residential area is likely to cause harmful interference in which case the user will be required to correct the interference at his own expense. This product must be operated as per the operating instructions provided. Do not make any alterations or modifications to the product. Any unauthorized alterations or modifications made to this product may require you to stop operating the product.

Canadian Radio Interference Regulations.

This Class A digital product complies with Canadian ICES-001. Règlement canadien sur les interférences radio. Ce produit numérique de classe A est conforme à la norme NMB-001.

Appendix D

Decontamination Declaration

Appendix D Decontamination Declaration

Decontamination Certificate

IMPORTANT NOTE: Please complete this form prior to this instrument, or any components, leaving your site and being returned to us, or, where applicable, prior to any work being carried out by a Michell engineer at your site.

Instrument			Serial Number	
Warranty Repair?	YES	NO	Original PO #	
Company Name			Contact Name	
Address				
Telephone #			E-mail address	
Reason for Return /Description of Fault:				
Has this equipment been exposed (internally or externally) to any of the following? Please circle (YES/NO) as applicable and provide details below				
Biohazards			YES	NO
Biological agents			YES	NO
Hazardous chemicals			YES	NO
Radioactive substances			YES	NO
Other hazards			YES	NO
Please provide details of any hazardous materials used with this equipment as indicated above (use continuation sheet if necessary)				
Your method of cleaning/decontamination				
Has the equipment been cleaned and decontaminated?			YES	NOT NECESSARY
Michell Instruments will not accept instruments that have been exposed to toxins, radio-activity or bio-hazardous materials. For most applications involving solvents, acidic, basic, flammable or toxic gases a simple purge with dry gas (dew point <-30°C) over 24 hours should be sufficient to decontaminate the unit prior to return. Work will not be carried out on any unit that does not have a completed decontamination declaration.				
Decontamination Declaration				
I declare that the information above is true and complete to the best of my knowledge, and it is safe for Michell personnel to service or repair the returned instrument.				
Name (Print)			Position	
Signature			Date	



F0121, Issue 2, December 2011

NOTES:



<http://www.michell.com>