



FLOWRATE INDICATOR / TOTALIZER

MS531
0314
0004

Electronic Register (ERS)

METER MOUNT

REMOTE MOUNT



*ERS-M
GA116P*

*ERS-RMA
ERS-RMP
GB116P*

Signal input flowmeter: NPN and Reed

Signal outputs: 4-20mA ref. flowrate, pulse ref. total and negative flow.



SAFETY INSTRUCTIONS



- Any responsibility is lapsed if the instructions and procedures as described in this manual are not followed.
- **LIFE SUPPORT APPLICATIONS:** The ERS is not designed for use in life support appliances, devices, or systems where malfunction of the product can reasonably be expected to result in a personal injury. Customers using or selling these products for use in such applications do so at their own risk and agree to fully indemnify the manufacturer and supplier for any damages resulting from such improper use or sale.
- Electro static discharge does inflict irreparable damage to electronics! Before installing or opening the unit, the installer has to discharge himself by touching a well-grounded object.
- This unit must be installed in accordance with the EMC guidelines (Electro Magnetic Compatibility).

DISPOSAL - WEEE DIRECTIVE



- *The WEEE Directive requires the recycling of waste electrical and electronic equipment in the European Union.*
- *Whilst the WEEE Directive does not apply to some of Macnaught's products, we support its policy and ask you to be aware of how to dispose of this product.*
- *The crossed out wheeled bin symbol illustrated and found on our products signifies that this product should not be disposed of in general waste or landfill.*
- *Please contact your local dealer national distributor or Macnaught Technical Services for information on product disposal.*

SAFETY RULES AND PRECAUTIONARY MEASURES

- The manufacturer accepts no responsibility whatsoever if the following safety rules and precautions instructions and the procedures as described in this manual are not followed.
- Modifications of the ERS implemented without preceding written consent from the manufacturer, will result in the immediate termination of product liability and warranty period.
- Installation, use, maintenance and servicing of this equipment must be carried out by authorized technicians.
- Check the mains voltage and information on the manufacturer's plate before installing the unit.
- Check all connections, settings and technical specifications of the various peripheral devices with the ERS supplied.
- Open the casing only if all leads are free of potential.
- Never touch the electronic components (ESD sensitivity).
- Never expose the system to heavier conditions than allowed according to the casing classification (see manufacture's plate and chapter 4.2.).
- If the operator detects errors or dangers, or disagrees with the safety precautions taken, then inform the owner or principal responsible.
- The local labor and safety laws and regulations must be adhered to.

ABOUT THE OPERATION MANUAL

This operation manual is divided into two main sections:

- The daily use of the unit is described in chapter 2 "Operation". These instructions are meant for users.
- The following chapters and appendices are exclusively meant for electricians/technicians. These provide a detailed description of all software settings and hardware installation guidance.

This operation manual describes the standard unit as well as most of the options available. For additional information, please contact your supplier.

A hazardous situation may occur if the ERS is not used for the purpose it was designed for or is used incorrectly. Please carefully note the information in this operating manual indicated by the pictograms:



A "**warning**" indicates actions or procedures which, if not performed correctly, may lead to personal injury, a safety hazard or damage of the ERS or connected instruments.



Caution !

A "**caution**" indicates actions or procedures which, if not performed correctly, may lead to personal injury or incorrect functioning of the ERS or connected instruments.



Note !

A "**note**" indicates actions or procedures which, if not performed correctly, may indirectly affect operation or may lead to an instrument response which is not planned.

Hardware version	:	02.01.xx
Software version	:	02.05.xx
Manual	:	MS531_0314_0004
© Copyright 2014	:	Macnaught Pty Ltd.

Information in this manual is subject to change without prior notice. The manufacturer is not responsible for mistakes in this material or for incidental damage caused as a direct or indirect result of the delivery, performance or use of this material.

© All rights reserved. No parts of this publication may be reproduced or used in any form or by any means without written permission of your supplier.

CONTENTS MANUAL

Safety instructions	2
Disposal - WEEE Directive	2
Safety rules and precautionary measures	2
About the operation manual	3
Contents manual.....	4
1. Introduction	5
1.1. System description of the ERS	5
2. Operational	6
2.1. General	6
2.2. Control panel.....	6
2.3. Operator information and functions	7
3. Configuration.....	8
3.1. Introduction	8
3.2. Programming SETUP-level.....	8
3.2.1. General	8
3.2.2. Overview functions SETUP level.....	11
3.2.3. Explanation OF SETUP-functions	12
1 - Total A	12
2 - Flowrate A.....	13
2 - Flowrate A (continued)	14
3 - Total B	14
4 - Flowrate B.....	14
5 - Display	15
6 - Power management	16
7 - Flowmeter	16
8 - Analog output.....	17
8 - Analog output (continued)	18
9 - Transistor output.....	18
A - Others.....	19
4. Installation.....	20
4.1. General directions	20
4.2. Installation / surrounding conditions	20
4.3. Dimensions- Enclosure	21
4.4. Installing the hardware.....	23
4.4.1. Introduction	23
4.4.2. Voltage selection sensor supply	24
4.4.3. Terminal connectors	24
5. Maintenance	27
5.1. General directions	27
5.2. Repair.....	27
Appendix A: Technical Specifications	28
Appendix B: Problem Solving.....	30
Index of this manual.....	31
List of figures in this manual	31

1. INTRODUCTION

1.1. SYSTEM DESCRIPTION OF THE ERS

Functions and features

The flowrate / totalizer model ERS is a microprocessor driven instrument designed to display flowrate, total and accumulated total based on the calculated differential or count up value of two separated flows.

This product has been designed with a focus on:

- ultra-low power consumption to allow long-life battery powered applications (type PB / PC),
- several mounting possibilities with aluminum or GRP enclosures for harsh industrial surroundings,
- ability to process all types of flowmeter signals,
- transmitting possibilities with analog / pulse outputs.

Flowmeter input

This manual describes the unit with a pulse type input from the flowmeter "-P version". Two flowmeters with a passive NPN or Reed switch signal output can be connected to the ERS.

Standard outputs

- Configurable pulse output: a scaled pulse mirroring a certain totalized differential or sum quantity. Maximum frequency 60Hz.; the pulse length can be set from 7,8msec up to 2 seconds.
- Flow direction output: related to the acc. total it will be switched when counting down.
- Configurable linear (0)4-20mA or 0-10V analog output with 10-bits resolution mirroring the actual differential or sum flowrate. Flowrate levels as well as the minimum and maximum signal output can be tuned.

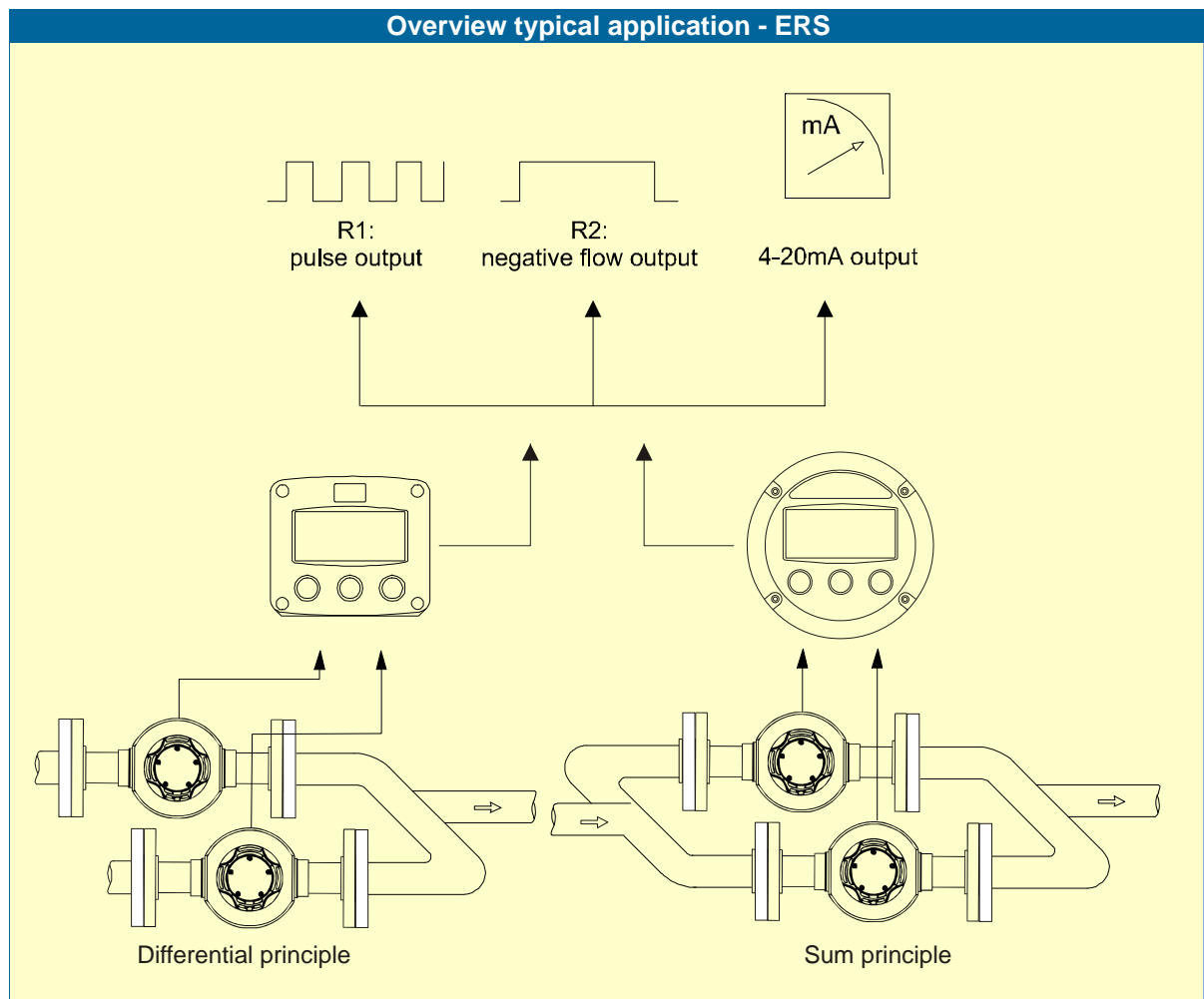

Fig. 1: Typical application for the ERS

Configuration of the unit

The ERS was designed to be implemented in many types of applications. For that reason, a SETUP-level is available to configure your ERS according to your specific requirements.

SETUP includes several important features, such as K-factors, measurement units, signal selection etc. All settings are stored in EEPROM memory and will not be lost in the event of power failure or a drained battery.

To extend the battery-life time (option), please make use of the power-management functions as described in chapter 3.2.3.

Display information

The unit has a large transfective LCD with all kinds of symbols and digits to display measuring units, status information, trend-indication and key-word messages.

Differential or sum Flowrate and totals can be displayed either with the small 8mm digits or with the 17mm digits. The flowrate and accumulated total of flow A and flow B can be displayed as well.

A backup of the total and accumulated total in EEPROM memory is made every minute.

Options

The following options are available: panel-mount, wall-mount, weather-proof enclosures and LED backlight.

2. OPERATIONAL

2.1. GENERAL

-  Caution !
- *The ERS may only be operated by personnel who are authorized and trained by the operator of the facility. All instructions in this manual are to be observed.*
 - *Take careful notice of the " Safety rules, instructions and precautionary measures " in the front of this manual.*

This chapter describes the daily use of the ERS. This instruction is meant for users / operators.

2.2. CONTROL PANEL

The following keys are available:

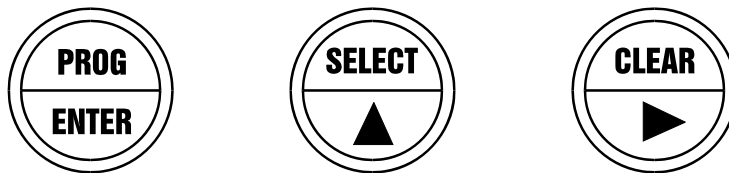

Fig. 2: Control Panel.

Functions of the keys



This key is used to program and save new values or settings.
It is also used to gain access to SETUP-level; please read chapter 3.



This key is used to SELECT differential or sum accumulated total, flowrate A and B and accumulated total A and B.

The arrow-key ▲ is used to increase a value after PROG has been pressed or to configure the unit; please read chapter 3.



Press this key twice to CLEAR the value for total.

The arrow-key ► is used to select a digit after PROG has been pressed or to configure the unit; please read chapter 3.

2.3. OPERATOR INFORMATION AND FUNCTIONS

In general, the ERS will always act at Operator level. The information displayed is dependant upon the SETUP-settings. All pulses generated by the connected flowmeter are measured by the ERS in the background, whichever screen refresh rate setting is chosen. After pressing a key, the display will be updated very quickly during a 30 second period, after which it will slow-down again.



Fig. 3: Example of display information during process.

For the Operator, the following functions are available:

- **Display flowrate / total or flowrate**

This is the main display information of the ERS. After selecting any other information, it will always return to this main display automatically.

The calculated Total (differential or sum) is displayed on the upper-line of the display and the calculated flowrate on the bottom line. It is possible to display flowrate only with the large 17mm digits; in this instance press the SELECT-key to read the total.

A negative flowrate might be displayed as soon as the returned flow - measured with flowmeter B - is more as the input flow.

When "-----" is shown, then the flowrate value is too high to be displayed. The arrows ◀ ▶ indicate the increase/decrease of the flowrate trend.

- **Clear total**

The value for total can be re-initialized. To do so, press CLEAR twice. After pressing CLEAR once, the flashing text "PUSH CLEAR" is displayed. To avoid re-initialization at this stage, press another key than CLEAR or wait for 20 seconds.

Re-initialization of total DOES NOT influence the accumulated total.

- **Display accumulated total**

When the SELECT-key is pressed, the calculated total and accumulated total are displayed.

The accumulated total cannot be re-initialized. The value will count up to 99,999,999,999. The unit and number of decimals are displayed according to the configuration settings for total.

- **Display flowrate / accumulated total flow A and B**

If enabled with the configuration of the ERS, the actual flows and accumulated totals for flow A and B will be displayed after pressing SELECT several times.

▪ **Low-battery alarm**

When the battery voltage drops, it must be replaced. At first "low-battery" will flash, but as soon as it is displayed continuously, the battery **MUST** be replaced shortly after!
Only original batteries supplied by the manufacturer may be used, else the guarantee and liability will be terminated. The remaining lifetime after the first moment of indication is generally several days up to some weeks.



Fig. 4: Example of low-battery alarm.

• **Alarm 01-03**

When "alarm" is displayed, please consult Appendix B: Problem Solving on page 36.

3. CONFIGURATION

3.1. INTRODUCTION

This and the following chapters are exclusively meant for electricians and non-operators. In these, an extensive description of all software settings and hardware connections are provided.



Caution !

- *Mounting, electrical installation, start-up and maintenance of the instrument may only be carried out by trained personnel authorized by the operator of the facility. Personnel must read and understand this Operating Manual before carrying out its instructions.*
- *The ERS may only be operated by personnel who are authorized and trained by the operator of the facility. All instructions in this manual are to be observed.*
- *Ensure that the measuring system is correctly wired up according to the wiring diagrams. The housing may only be opened by trained personnel.*
- *Take careful notice of the " Safety rules, instructions and precautionary measures " in the front of this manual.*

3.2. PROGRAMMING SETUP-LEVEL

3.2.1. GENERAL

Configuration of the ERS is done at SETUP-level. SETUP-level is reached by pressing the PROG/ENTER key for 7 seconds; at which time, both arrows \blacktriangleleft will be displayed. In order to return to the operator level, PROG will have to be pressed for three seconds. Alternatively, if no keys are pressed for 2 minutes, the unit will exit SETUP automatically. SETUP can be reached at all times while the ERS remains fully operational.



Note !

Note: A pass code may be required to enter SETUP. Without this pass code access to SETUP is denied.

To enter SETUP-level:

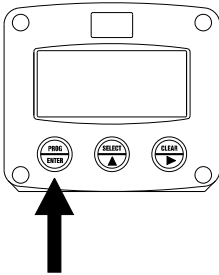

Press  for 7 seconds

Matrix structure SETUP-level:

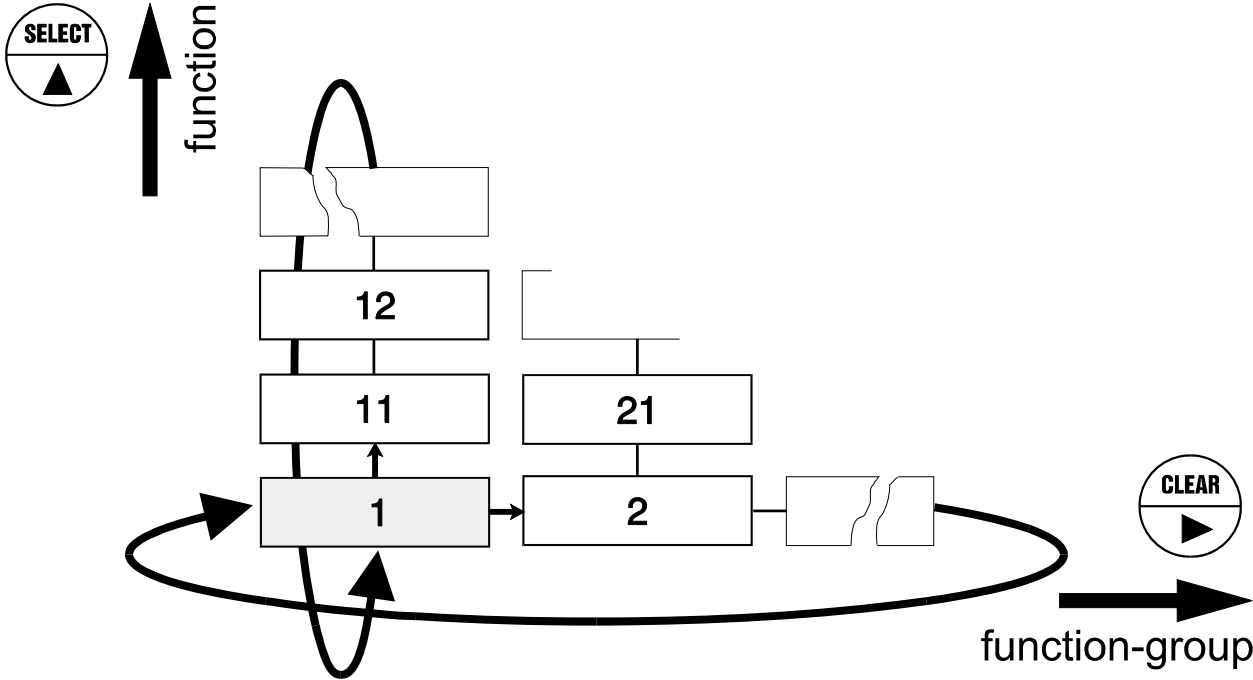

SCROLLING THROUGH SETUP-LEVEL

Selection of function-group and function:
SETUP is divided into several function groups and functions.

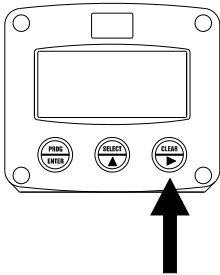

Select function-group with 

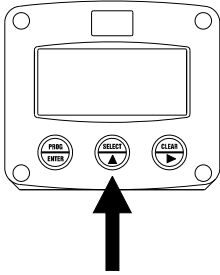





Select function with 

Each function has a unique number, which is displayed below the word "SETUP" at the bottom of the display. The number is a combination of two figures. The first figure indicates the function-group and the second figure the sub-function. Additionally, each function is expressed with a keyword.

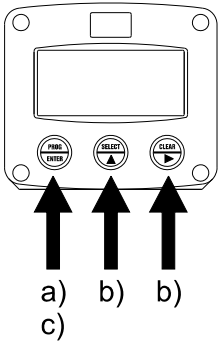
After selecting a sub-function, the next main function is selected by scrolling through all "active" sub-functions (e.g. 1[▲], 11[▲], 12[▲], 13[▲], 14[▲], 1[▶], 2[▶], 3[▲], 31 etc.).

To change or select a value:



- a) press  briefly; **PROGRAM** will start flash
- b) select or enter value with  and / or 
- c) press  to confirm the value / selection.

To change a value, use [▶] to select the digits and [▲] to increase that value.

To select a setting, both [▲] and [▶] can be used.

If the new value is invalid, the increase sign [▲] or decrease-sign [▼] will be displayed while you are programming.

When data is altered but ENTER is not pressed, then the alteration can still be cancelled by waiting for 20 seconds or by pressing ENTER for three seconds: the PROG-procedure will be left automatically and the former value reinstated.



Note: alterations will only be set after ENTER has been pressed!

To return to OPERATOR-level:

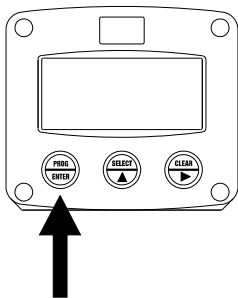

Press  for 3 seconds

In order to return to the operator level, PROG will have to be pressed for three seconds. Also, when no keys are pressed for 2 minutes, SETUP will be left automatically.

3.2.2. OVERVIEW FUNCTIONS SETUP LEVEL

SETUP FUNCTIONS AND VARIABLES			
1	TOTAL A		
	11	UNIT	L - m3 - kg - lb - GAL - USGAL - bbl - no unit
	12	DECIMALS	0 - 1 - 2 - 3 (Ref: displayed value)
	13	K-FACTOR:	0.000010 - 9,999,999
	14	DECIMALS K-FACTOR	0 - 6
2	FLOWRATE A		
	21	UNIT	mL, L, m3, mg, g, kg, ton, GAL, bbl, lb, cf, rev, no unit
	22	TIME UNIT	sec - min - hour - day
	23	DECIMALS	0 - 1 - 2 - 3 (Ref: displayed value)
	24	K-FACTOR	0.000010 - 9,999,999
	25	DECIMALS K-FACTOR	0 - 6
	26	FILTER	1 - 99
	27	PERIOD	0.1 - 99.9 seconds
3	TOTAL B		
	31	K-FACTOR	0.000010 - 9,999,999
	32	DECIMALS K-FACTOR	0 - 6
4	FLOWRATE B		
	41	K-FACTOR	0.000010 - 9,999,999
	42	DECIMALS K-FACTOR	0 - 6
5	DISPLAY		
	51	FUNCTION	total - flowrate - all
	52	CALCULATE	differential - add
	53	MEASUREMENT	bi-directional - not negative - threshold - stationary
	54	STATIONARY FLOWRATE	0000.000 - 9999999 units/time unit
	55	STATIONARY TOTAL	0000.000 - 9999.999 units/hr
6	POWER MANAGEMENT		
	61	LCD UPDATE	fast - 1 sec - 3 sec - 15 sec - 30 sec - off
	62	BATTERY MODE	operational - shelf
7	FLOWMETER		
	71	SIGNAL A	npn - npn_lp - reed - reed_lp
	72	SIGNAL B	npn - npn_lp - reed - reed_lp
8	ANALOG		
	81	OUTPUT	disable - enable
	82	MINIMUM SIGNAL	0000.000 - 9,999,999 unit/time unit
	83	MAXIMUM SIGNAL	0000.000 - 9,999,999 unit/time unit
	84	CUT-OFF	0.0 - 9.9%
	85	TUNE MIN - 4mA / 0V	0 - 9,999
	86	TUNE MAX- 20mA / 10V	0 - 9,999
	87	FILTER	00 - 99
9	IMPULSE		
	91	PERIOD TIME	0 - 250
	92	IMPULSE PER	X,XXX,XXX quantity
A	OTHERS		
	A1	TYPE / MODEL	ERS
	A2	SOFTWARE VERSION	
	A3	SERIAL NO.	
	A4	PASSWORD	0000 - 9999
	A5	TAGNUMBER	0000000 - 9999999

3.2.3. EXPLANATION OF SETUP-FUNCTIONS

1 - TOTAL A	
MEASUREMENT UNIT 11	<p>SETUP - 11 determines the measurement unit for total, accumulated total and pulse output for BOTH A and B. The following units can be selected:</p> <p style="text-align: center;">L - m3 - kg - lb. - GAL - USGAL - bbl - _ (no unit).</p> <p>Alteration of the measurement unit will have consequences for operator and SETUP-level values. Please note that the K-factor has to be adapted as well; the calculation is not done automatically.</p>
DECIMALS 12	<p>The decimal point determines for total, accumulated total and pulse output the number of digits following the decimal point for BOTH A and B. The following can be selected:</p> <p style="text-align: center;">000000 - 111111.1 - 22222.22 - 3333.333</p>
K-FACTOR 13	<p>With the K-factor, the flowmeter pulse signals are converted to a quantity. The K-factor is based on the number of pulses generated by the flowmeter per selected measurement unit (SETUP 11), for example per cubic meter. The more accurate the K-factor, the more accurate the functioning of the system will be.</p> <p>Example 1: Calculating the K-factor. <i>Let us assume that the flowmeter generates 2.4813 pulses per liter and the selected unit is "cubic meters / m³". A cubic meter consists of 1000 parts of one liter which implies 2,481.3 pulses per m³. So, the K-factor is 2,481.3. Enter for SETUP - 13: "2481300" and for SETUP - 14 - decimals K-factor "3".</i></p> <p>Example 2: Calculating the K-factor. <i>Let us assume that the flowmeter generates 6.5231 pulses per gallon and the selected measurement unit is gallons. So, the K-Factor is 6.5231. Enter for SETUP - 13: "6523100" and for SETUP - 14 decimals K-factor "6".</i></p>
DECIMALS K-FACTOR 14	<p>This setting determines the number of decimals for the K-factor entered. (SETUP 13). The following can be selected:</p> <p style="text-align: center;">0 - 1 - 2 - 3 - 4 - 5 - 6</p> <p>Please note that this setting influences the accuracy of the K-factor indirectly. (i.e. the position of the decimal point and thus the value given) This setting has NO influence on the displayed number of digits for total (SETUP 12)!</p>

2 - FLOWRATE A

The settings for total and flowrate are entirely separate. In this way, different units of measurement can be used for each e.g. cubic meters for total and liters for flowrate.

The display update time for flowrate is one second or more.

Note: these settings also influence the analog output.

MEASUREMENT UNIT 21	SETUP - 21 determines the measurement unit for flowrate for BOTH A and B. mL - L - m3 - mg - gr - kg - ton - GAL - bbl - lb - cf - rev (revolutions for RPM) - _ (no unit). Alteration of the measurement unit will have consequences for operator and SETUP-level values. Please note that the K-factor has to be adapted as well; the calculation is not done automatically.			
TIME UNIT 22	The flowrate can be calculated per second (SEC), minute (MIN), hour (HR) or day (DAY). This selection is valid for BOTH A and B flow.			
DECIMALS 23	This setting determines for flowrate the number of digits following the decimal point for BOTH A and B. The following can be selected: 00000 - 1111.1 - 2222.22 - 3333.333			
K-FACTOR 24	With the K-factor, the flowmeter pulse signals are converted to a flowrate. The K-factor is based on the number of pulses generated by the flowmeter per selected measurement unit (SETUP 21), for example per liter. The more accurate the K-factor, the more accurate the functioning of the system will be. For examples read SETUP 13.			
DECIMALS K-FACTOR 25	This setting determines the number of decimals for the K-factor (SETUP 24). The following can be selected: 0 - 1 - 2 - 3 - 4 - 5 - 6 Please note that this SETUP - influences the accuracy of the K-factor indirectly. This setting has NO influence on the displayed number of digits for "flowrate" (SETUP 23)!			
FILTER 26	This function is used to stabilize the flowrate reading. With the help of this digital filter a more stable but less actual reading can be obtained. The filter principal is based on three input values: the filter level (01-99), the last calculated flowrate on both the A / B flow and the last average value. The higher the filter level, the longer the response time on a value change will be. Below, several filter levels with there response times are indicated:			
FILTER VALUE	RESPONSE TIME ON STEP CHANGE OF ANALOG VALUE. TIME IN SECONDS			
	50% INFLUENCE	75% INFLUENCE	90% INFLUENCE	99% INFLUENCE
01	filter disabled	filter disabled	filter disabled	filter disabled
02	0.1 second	0.2 second	0.4 second	0.7 second
03	0.2 second	0.4 second	0.6 second	1.2 seconds
05	0.4 second	0.7 second	1.1 seconds	2.1 seconds
10	0.7 second	1.4 seconds	2.2 seconds	4.4 seconds
20	1.4 seconds	2.8 seconds	4.5 seconds	9.0 seconds
30	2.1 seconds	4 seconds	7 seconds	14 seconds
50	3.5 seconds	7 seconds	11 seconds	23 seconds
75	5.2 seconds	10 seconds	17 seconds	34 seconds
99	6.9 seconds	14 seconds	23 seconds	45 seconds

Continued next page >>>



2 - FLOWRATE A (CONTINUED)

PERIOD 27	<p>The flowrate is calculated by counting the number of pulses within a certain time, for example 1 second. The longer the time the more accurate the flowrate will be. The maximum value is 999.9 seconds.</p> <p>Note: <i>this setting does influence the update time for the analog output directly (maximum update 10 times a second). If the output response is too slow, decrease the number of pulses.</i></p> <p>Note: <i>the shorter the time, the higher the power consumption of the unit will be (important for battery powered applications).</i></p>
----------------------------	----------------------------------------------------------------------------------------------------------------------------------------------------------------------------------------------------------------------------------------------------------------------------------------------------------------------------------------------------------------------------------------------------------------------------------------------------------------------------------------------------------------------------------------------------------------------------------

3 - TOTAL B

K-FACTOR 31	<p>With the K-factor, the flowmeter pulse signals are converted to a quantity. The K-factor is based on the number of pulses generated by the flowmeter per selected measurement unit (SETUP 11), for example per cubic meter. The more accurate the K-factor, the more accurate the functioning of the system will be.</p> <p>For examples: please read SETUP 13</p>
DECIMALS K-FACTOR 32	<p>This setting determines the number of decimals for the K-factor (SETUP 31). The following can be selected:</p> <p style="text-align: center;">0 - 1 - 2 - 3 - 4 - 5 - 6</p> <p>Please note that this function influences the accuracy of the K-factor indirectly.</p>

4 - FLOWRATE B

K-FACTOR 41	<p>With the K-factor, the flowmeter pulse signals are converted to a flowrate. The K-factor is based on the number of pulses generated by the flowmeter per selected measurement unit (SETUP 21), for example per liter. The more accurate the K-factor, the more accurate the functioning of the system will be. For examples read SETUP 13.</p>
DECIMALS K-FACTOR 42	<p>This setting determines the number of decimals for the K-factor (SETUP 24). The following can be selected:</p> <p style="text-align: center;">0 - 1 - 2 - 3 - 4 - 5 - 6</p> <p>Please note that this SETUP - influences the accuracy of the K-factor indirectly.</p>

5 - DISPLAY	
FUNCTION 51	The operator information can be set to: TOTAL: the differential total and flowrate will be displayed simultaneously. Press SELECT to display the acc total. FLOWRATE: only the flowrate will be displayed. First after pressing the SELECT the total and acc. total will be displayed. ALL: As FLOWRATE. After pressing SELECT several times, flowrate A, Total A, flowrate B and Total B will be displayed as well.
CALCULATE 52	The unit can be set to calculate and display either the differential total / flowrate or to add (sum function) both flows.
MEASUREMENT 53	To solve undesired display readings during low or even negative consumption situations, four different measurement methods have been implemented. Be aware that the selection does influence the analog output value (ref. flowrate) as well. bi-directional <u>Displayed flowrate:</u> positive and negative <u>Displayed total:</u> positive and negative not negative <u>Displayed flowrate:</u> only positive or zero <u>Displayed total:</u> positive and negative threshold <u>Displayed flowrate:</u> as soon as the flowrate is lower as setting 54 or negative, flowrate zero will be displayed. <u>Displayed total:</u> as soon as the flowrate is lower as setting 54 or negative, totalisation will stop. stationary <u>Displayed flowrate:</u> as soon as the flowrate is lower as setting 54 or negative, the stationary flowrate (setting 54) will be displayed. <u>Displayed total:</u> as soon as the flowrate is lower as setting 54 or negative, stationary totalisation (setting 55) will be activated. However, if the value of setting 55 is zero, totalisation will be positive and negative.
STATIONARY FLOWRATE 54	Enter here the flowrate according setting 53 - threshold or stationary. The time and measuring units are according to FLOWRATE - setting 21 and 22. <u>In case of selection "threshold":</u> flowrate zero will be displayed as soon as the flowrate will be lower as this setting. <u>In case of selection "stationary":</u> as soon as the flowrate is lower as this setting, this flowrate will be displayed. However, if the flowmeters do not generate pulses, the displayed flowrate will be zero
STATIONARY TOTAL 55	Enter here a flowrate per hour according setting 53 - stationary. The measuring unit is according to TOTAL - setting 11. This flowrate is converted to a total which will be used as long as the flowrate is lower as setting 54. However, if the flowmeters do not generate pulses, the totalisation will stop. This function is disabled if value zero has been entered.

6 - POWER MANAGEMENT

When used with the internal battery option, the user can expect reliable measurement over a long period of time. The ERS has several smart power management functions to extend the battery life time significantly. Two of these functions can be set:

LCD NEW 61	<p>The calculation of the display-information influences the power consumption significantly. When the application does not require a fast display update, it is strongly advised to select a slow refresh rate. Please understand that NO information will be lost; every pulse will be counted and the output signals will be generated in the normal way. The following can be selected:</p> <p style="text-align: center;">Fast - 1 sec - 3 sec - 15 sec - 30 sec - off.</p> <p>Example 3: Battery life-time <i>battery life-time with a coil pick-up, 1KHz. pulses and FAST update: about 2 years.</i> <i>battery life-time with a coil pick-up, 1KHz. pulses and 1 sec update: about 5 years.</i></p> <p>Note: after a button has been pressed by the operator - the display refresh rate will always switch to FAST for 30 seconds. When "OFF" is selected, the display will be switched off after 30 seconds and will be switched on as soon as a button has been pressed.</p>
BATTERY-MODE 62	<p>The unit has two modes: operational or shelf. After "shelf" has been selected, the unit can be stored for several years; it will not count pulses, the display is switched off but all settings and totals are stored. In this mode, power consumption is extremely low. To wake up the unit again, press the SELECT-key twice.</p>



Note !

7 - FLOWMETER

SIGNAL A 71	<p>The ERS is able to handle several types of input signal. The type of flowmeter pickup / signal for input A is selected with SETUP 71.</p> <p>Note: The selections "active pulse" offer a detection level of 50% of the supply voltage.</p> <p>Read also par. 4.4.3. Flowmeter input terminal 09-11.</p>			
SIGNAL B 72	<p>The ERS is able to handle several types of input signal. The type of flowmeter pickup / signal for input B is selected with SETUP 72.</p> <p>Note: The selections "active pulse" offer a detection level of 50% of the supply voltage.</p> <p>Read also par. 4.4.3. Flowmeter input terminal 12-14.</p>			
TYPE OF SIGNAL	EXPLANATION	RESISTANCE	FREQ. / MV	REMARK
NPN	NPN input	100K pull-up	6 kHz.	(open collector)
NPN - LP	NPN input with low pass filter	100K pull-up	2.2 kHz.	(open collector) less sensitive
REED	Reed-switch input	1M pull-up	1.2 kHz.	
REED - LP	Reed-switch input with low pass filter	1M pull-up	120 Hz.	Less sensitive



Note !



Note !

8 - ANALOG OUTPUT

A linear analog (0)4-20mA or 0-10V signal is generated according to the calculated differential or sum flowrate with a 10 bits resolution. The settings for flowrate (SETUP - 2) influence the analog output directly.

The relationship between rate and analog output is set with the following functions:

DISABLE / ENABLE 81	The analog output can be disabled. 3.5mA will be generated if a power supply is available but the output is disabled (this is not valid in case type AB or AU has been supplied).			
MINIMUM FLOWRATE 82	Enter here the flowrate at which the output should generate the minimum signal (0/4mA or 0V) - in most applications at flowrate "zero". The number of decimals displayed depend upon SETUP 23. The time and measuring units (L/min for example) are dependant upon SETUP 21 and 22 but are not displayed.			
MAXIMUM FLOWRATE 83	Enter here the flowrate at which the output should generate the maximum signal (20mA or 10V) - in most applications at maximum flow. The number of decimals displayed depend upon SETUP 23. The time and measuring units (L/min for example) are dependant upon SETUP 21 and 22 but can not be displayed.			
CUT-OFF 84	To ignore leakage of the flow for example, a low flow cut-off can be set as a percentage of the full range of 16mA (or 20mA / 10V). When the flow is less than the required rate, the current will be 4mA. Examples:			
4mA (SETUP 82)	20mA (SETUP 83)	CUT-OFF (SETUP 84)	REQUIRED RATE	OUTPUT
0 L/min	100 L/min	2%	$(100-0)*2\% = 2.0 \text{ L/min}$	$4+(16*2\%) = 4.32\text{mA}$
20 L/min	800 L/min	3.5%	$(800-20)*3.5\% = 27.3 \text{ L/min}$	$4+(16*3.5\%) = 4.56\text{mA}$

TUNE MIN / 4MA
85

The initial minimum analog output value is 0/4mA or 0V. However, this value might differ slightly due to external influences such as temperature for example. The 0/4mA or 0V value can be tuned precisely with this setting.

- ***Before tuning the signal, be sure that the analog signal is not being used for any application!***

After pressing PROG, the current will be about 4mA (or 0mA / 0V). The current can be increased / decreased with the arrow-keys and is directly active. Press ENTER to store the new value.

Remark: the analog output value can be programmed "up-side-down" if desired, so 20mA at minimum flowrate for example!

TUNE MAX / 20MA
86

The initial maximum analog output value is 20mA (or 10V). However, this value might differ slightly due to external influences such as temperature for example. The 20mA value (or 10V) can be tuned precisely with this setting.

- ***Before tuning the signal, be sure that the analog signal is not being used for any application!***

After pressing PROG, the current will be about 20mA. The current can be increased / decreased with the arrow-keys and is directly active. Press ENTER to store the new value.

Remark: the analog output value can be programmed "up-side-down" if desired, so 4mA at maximum flowrate for example!

Continued next page >>>



Note !



8 - ANALOG OUTPUT (CONTINUED)

FILTER 87	This function is used to stabilize the analog output signal. The output value is updated every 0.1 second. With the help of this digital filter a more stable but less precise reading can be obtained. The filter principal is based on three input values: the filter level (01-99), the last analog output value and the last average value. The higher the filter level, the longer the response time on a value change will be. Below, several filter levels with their response times are indicated:			
FILTER VALUE	RESPONSE TIME ON STEP CHANGE OF ANALOG VALUE. TIME IN SECONDS			
	50% INFLUENCE	75% INFLUENCE	90% INFLUENCE	99% INFLUENCE
01	filter disabled	filter disabled	filter disabled	filter disabled
02	0.1 second	0.2 second	0.4 second	0.7 second
03	0.2 second	0.4 second	0.6 second	1.2 seconds
05	0.4 second	0.7 second	1.1 seconds	2.1 seconds
10	0.7 second	1.4 seconds	2.2 seconds	4.4 seconds
20	1.4 seconds	2.8 seconds	4.5 seconds	9.0 seconds
30	2.1 seconds	4 seconds	7 seconds	14 seconds
50	3.5 seconds	7 seconds	11 seconds	23 seconds
75	5.2 seconds	10 seconds	17 seconds	34 seconds
99	6.9 seconds	14 seconds	23 seconds	45 seconds

9 - TRANSISTOR OUTPUT

One transistor output is available as scaled pulse output according to the calculated differential or sum total.

PERIOD TIME PULSE OUTPUT 91	The period time determines the time that the transistor will be switched; in other words the pulse length. The minimum time between the pulses is as long as the selected period time. One period is approx. 7.8 msec. If the value selected is "zero", the pulse output is disabled. The maximum value is 255 periods. Note: <i>If the frequency should go out of range - when the flowrate increases for example - an internal buffer will be used to "store the missed pulses": As soon as the flowrate reduces again, the buffer will be "emptied". It might be that pulses will be missed due to a buffer-overflow, so it is advised to program this setting within it's range.</i>		
	NUMBER OF PERIODS	PERIOD TIME	MAX. FREQUENCY
	0	disabled	disabled
	1	0,0078 seconds	64 Hz.
	2	0,0156 seconds	32 Hz.
	3	0,0234 seconds	21 Hz.
	64	0,5000 seconds	1 Hz.
	255	1,9922 seconds	0.25 Hz.
PULSE PER 92	According to the measurement unit settings for total, a pulse will be generated every X-quantity. Enter this quantity here while taking the displayed decimal position and measuring unit into account.		



Note !

A - OTHERS	
TYPE OF MODEL A1	For support and maintenance it is important to have information about the characteristics of the ERS. Your supplier will ask for this information in the case of a serious breakdown or to assess the suitability of your model for upgrade considerations.
VERSION SOFTWARE A2	For support and maintenance it is important to have information about the characteristics of the ERS. Your supplier will ask for this information in the case of a serious breakdown or to assess the suitability of your model for upgrade considerations.
SERIAL NUMBER A3	For support and maintenance it is important to have information about the characteristics of the ERS. Your supplier will ask for this information in the case of a serious breakdown or to assess the suitability of your model for upgrade considerations.
PASS CODE A4	All SETUP-values can be pass code protected. This protection is disabled with value 0000 (zero). Up to and including 4 digits can be programmed, for example 1234.
TAGNUMBER A5	For identification of the unit a unique tag number of maximum 7 digits can be entered.

4. INSTALLATION

4.1. GENERAL DIRECTIONS



- Mounting, electrical installation, start-up and maintenance of this instrument may only be carried out by trained personnel authorized by the operator of the facility. Personnel must read and understand this Operating Manual before carrying out its instructions.
- The ERS may only be operated by personnel who are authorized and trained by the operator of the facility. All instructions in this manual are to be observed.
- Ensure that the measuring system is correctly wired up according to the wiring diagrams. Protection against accidental contact is no longer assured when the housing cover is removed or the panel cabinet has been opened (danger from electrical shock). The housing may only be opened by trained personnel.
- Take careful notice of the " Safety rules, instructions and precautionary measures " at the front of this manual.

4.2. INSTALLATION / SURROUNDING CONDITIONS

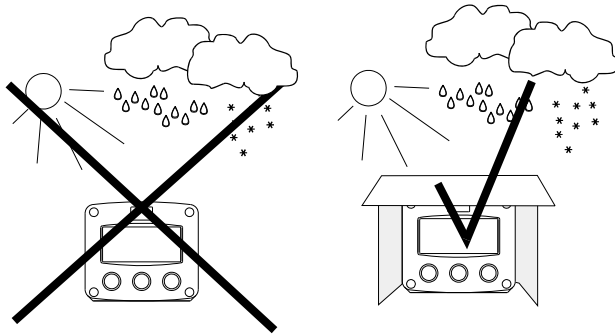

Take the relevant IP classification of the casing into account (see manufactures plate). Even an IP67 (NEMA 4X) casing should NEVER be exposed to strongly varying (weather) conditions.

When panel-mounted, the unit is IP65 (NEMA 4X)!

When used in very cold surroundings or varying climatic conditions, take the necessary precautions against moisture by placing a dry sachet of silica gel, for example, inside the instrument case.

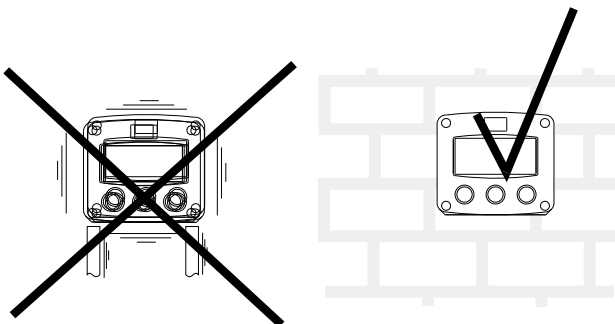

Mount the ERS on a solid structure to avoid vibrations.

4.3. DIMENSIONS- ENCLOSURE

Aluminum enclosures ERS-RMA:

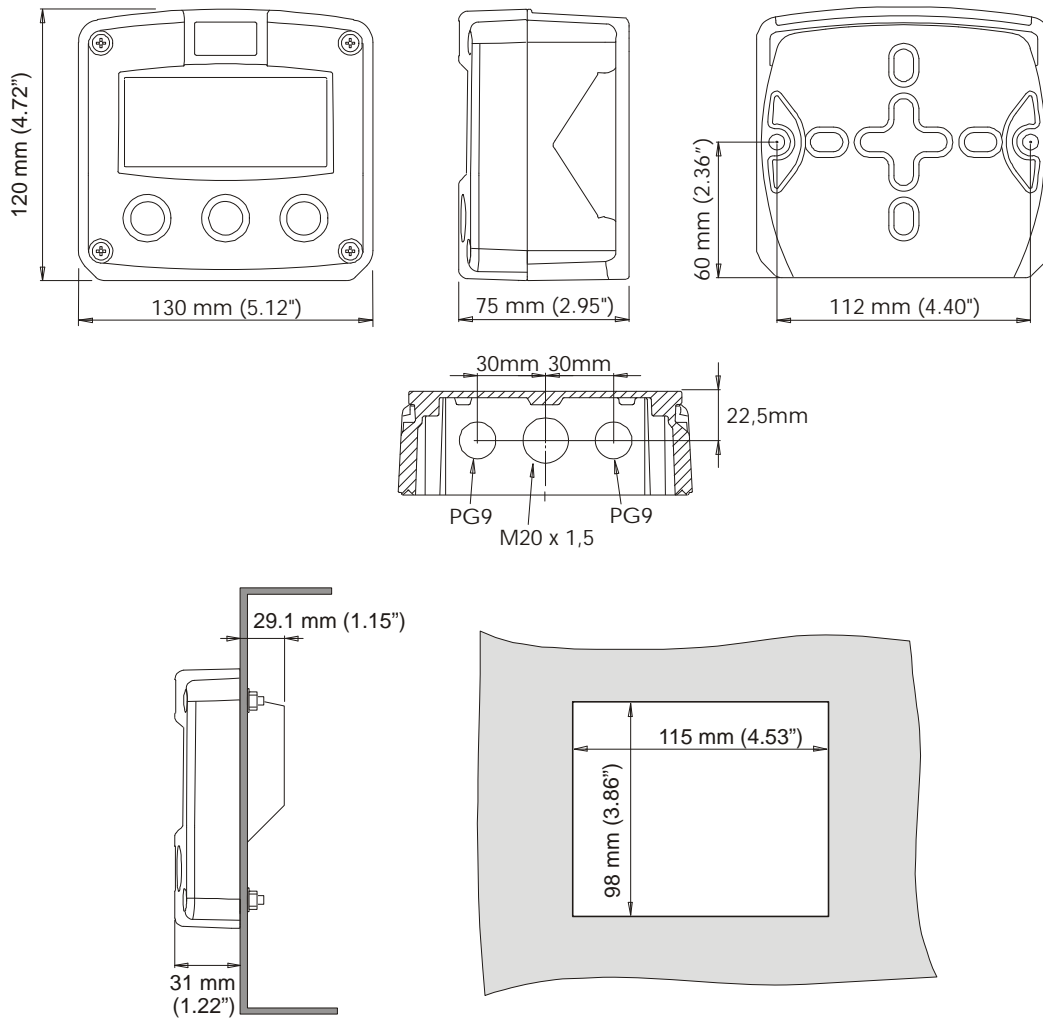

Fig. 5: Dimensions Aluminum enclosures.

Plastic (GRP) enclosures ERS-RMP:

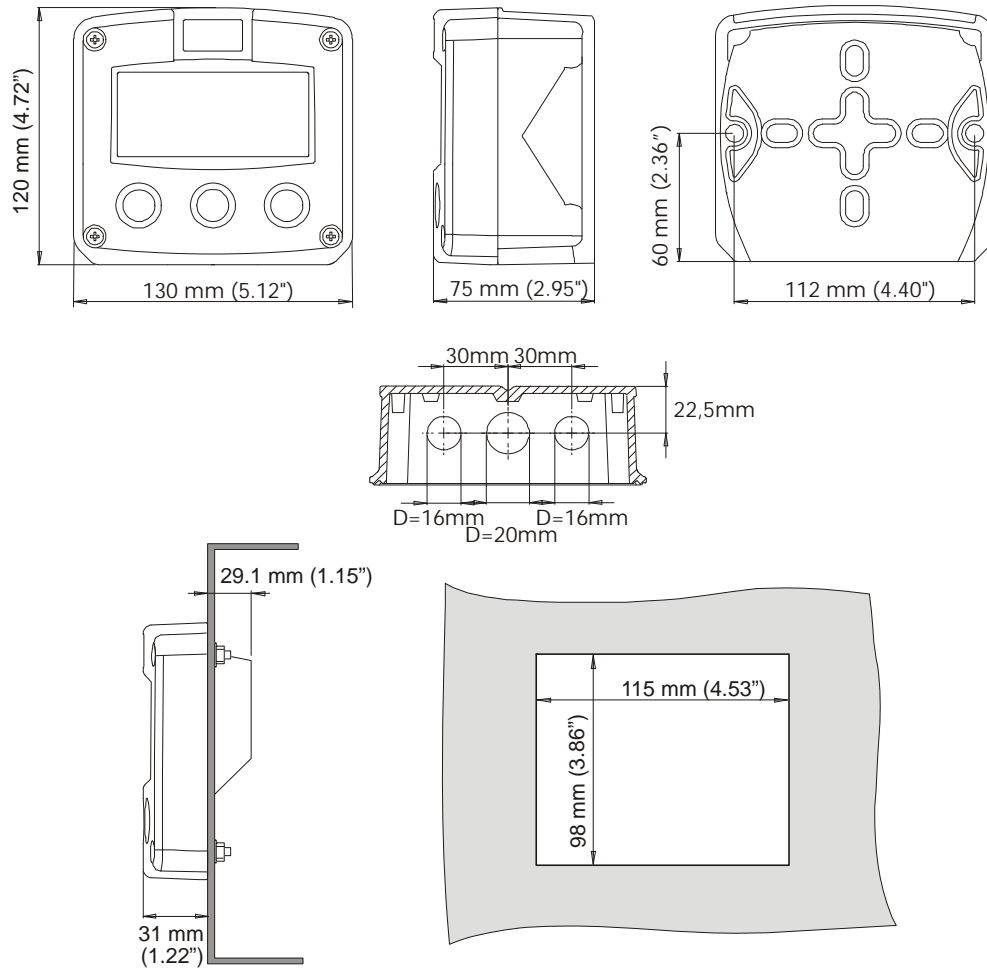

Fig. 6: Dimensions GRP enclosures.

Meter Mount enclosures ERS-M:

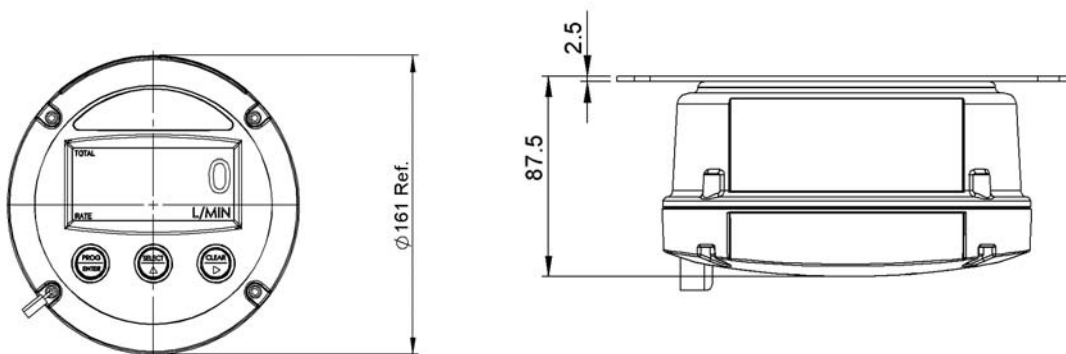

Fig. 7: Dimensions ERS-M series Meter mount enclosures.

4.4. INSTALLING THE HARDWARE



4.4.1. INTRODUCTION

- Electro static discharge does inflict irreparable damage to electronics! Before installing or opening the unit, the installer has to discharge himself by touching a well-grounded object.
- This unit must be installed in accordance with the EMC guidelines (Electro Magnetic Compatibility).



Aluminum enclosures

- When installed in an aluminum enclosure and a potentially explosive atmosphere requiring apparatus of equipment protection level Ga and Da, the unit must be installed such that, even in the event of rare incidents, an ignition source due to impact or friction sparks between the enclosure and iron/steel is excluded.
- Do ground the aluminum enclosure properly as indicated if necessary. The green / yellow wire between the back-casing and removable terminal-block may never be removed.

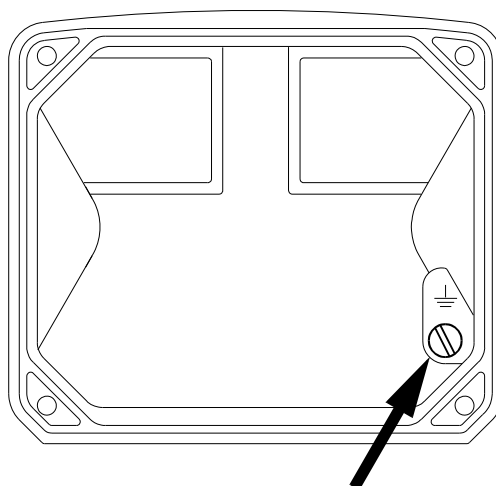

Fig. 8: Grounding aluminum enclosure

FOR INSTALLATION, PAY EMPHATIC ATTENTION TO:

- Separate cable glands with effective IP67 (NEMA4X) seals for all wires.
- Unused cable entries: ensure that you fit IP67 (NEMA4X) plugs to maintain rating.
- A reliable ground connection for both the sensor, and if applicable, for the metal casing.
- An effective screened cable for the input signal, and grounding of its screen to terminal 9 (GND) or at the sensor itself, whichever is appropriate to the application.

4.4.2. VOLTAGE SELECTION SENSOR SUPPLY

Battery powered and output loop-powered applications:

Terminal 11 provides a limited supply voltage of 3.2 V DC (coil signals 1.2V) for the signal output of the flowmeter.



Note: This voltage MAY NOT be used to power the flowmeters electronics, converters etc, as it will not provide adequate sustained power ! All energy used by the flowmeters pick-up will directly influence the battery life-time. It is strongly advised to use a "zero power" pickup such as a coil or reed-switch when operating without external power. It is possible to use some low power NPN output signals, but the battery life time will be significantly reduced (consult your distributor).

4.4.3. TERMINAL CONNECTORS

The following terminal connectors are available:

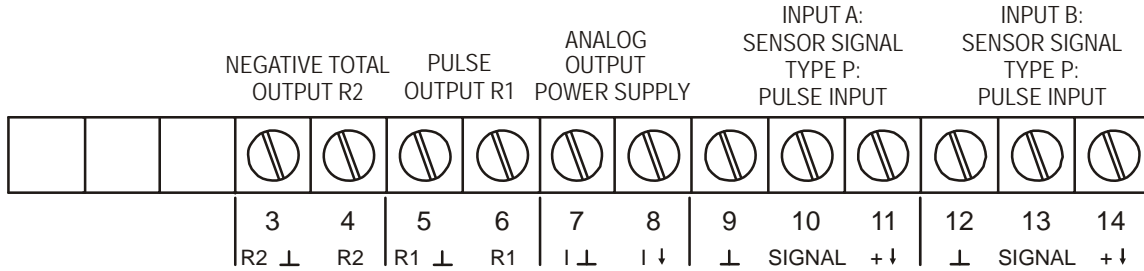

Fig. 9: Overview of terminal connectors standard configuration ERS and options.

REMARKS: TERMINAL CONNECTORS:

Terminal 05-06; Transistor output R1:

This output is a pulse output. With SETUP A, the function of this output is set. The maximum pulse frequency of this output is 60Hz.

Terminal 03-04; negative total - Transistor output R2:

This output is switched in case the calculated accumulated total counts down. This is the case as soon as the measured flow B is more as flow A.

Passive Transistor output:

A passive transistor output is available with this option. Max. driving capacity 300mA@50V DC.

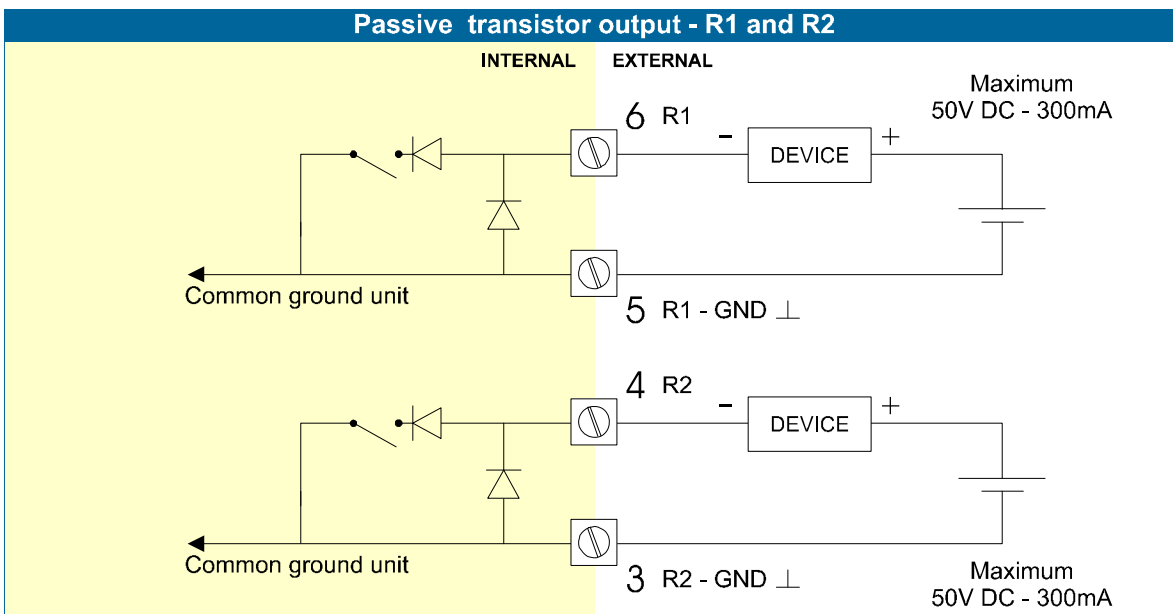

Terminal 07-08; basic POWER SUPPLY - output loop powered:

Connect an external power supply of 8-30VDC to these terminals or a 4-20mA loop.

Do not connect the "-" to terminal 7 and the "+" to terminal 8. When power is applied to these terminals, the (optional) internal battery will be disabled / enabled automatically to extend the battery life time.



Caution! *Only valid for standard passive output!*

Terminal 07-08 analog output (SETUP 7) :

An analog output signal proportional to the calculated differential / sum flowrate is available as standard.

Type AP:

A passive 4-20mA signal proportional to the calculated differential / sum flowrate is available with this option. When a power supply is connected but the output is disabled, a 3.5mA signal will be generated. Max. driving capacity 1000 Ohm. This output does loop power the unit as well.

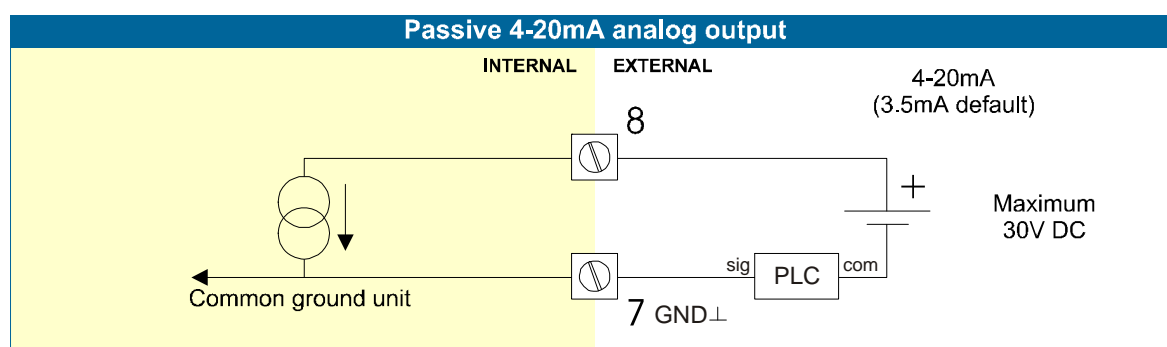
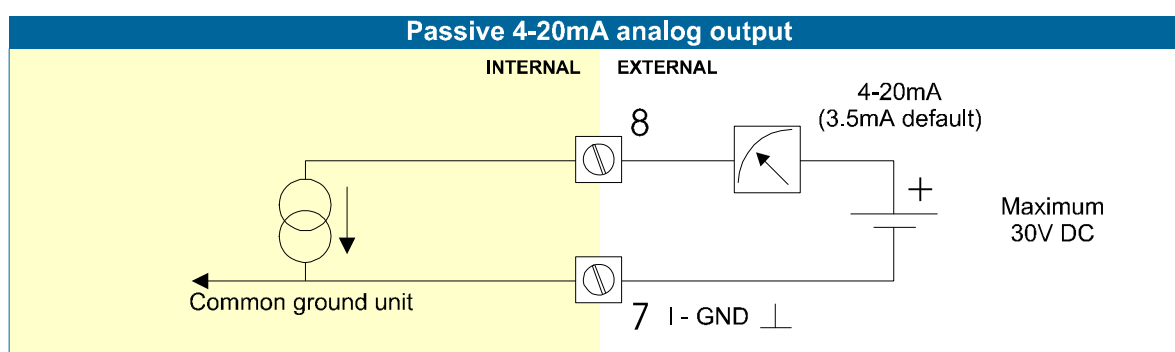
**Terminal 09-11; Flowmeter input:**

Two basic types of flowmeter signals can be connected to the unit: NPN or Reed switch. The screen of the signal wire must be connected to the common ground terminal 09 (unless earthed at the sensor itself).

The maximum input frequency is approximately 10 kHz (depending on the type of signal). The input signal type has to be selected with the correct SETUP-function (read par. 3.2.3.)

Pulse-signal NPN / NPN-LP:

The ERS is suitable for use with flowmeters which have a NPN output signal. For reliable pulse detection, the pulse amplitude has to go below 1.2V. Signal setting NPN-LP employs a low-pass signal noise filter, which limits the maximum input frequency - read par. 3.2.3.

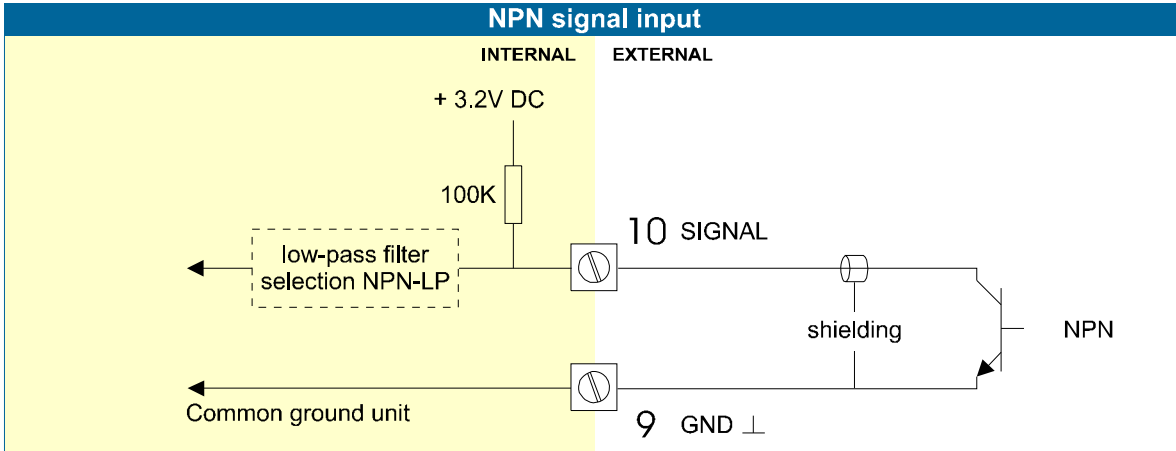

Reed-switch:

The ERS is suitable for use with flowmeters which have a reed-switch. To avoid pulse bounce from the reed-switch, it is advised to select REED LP - low-pass filter (read par. 3.2.3.)

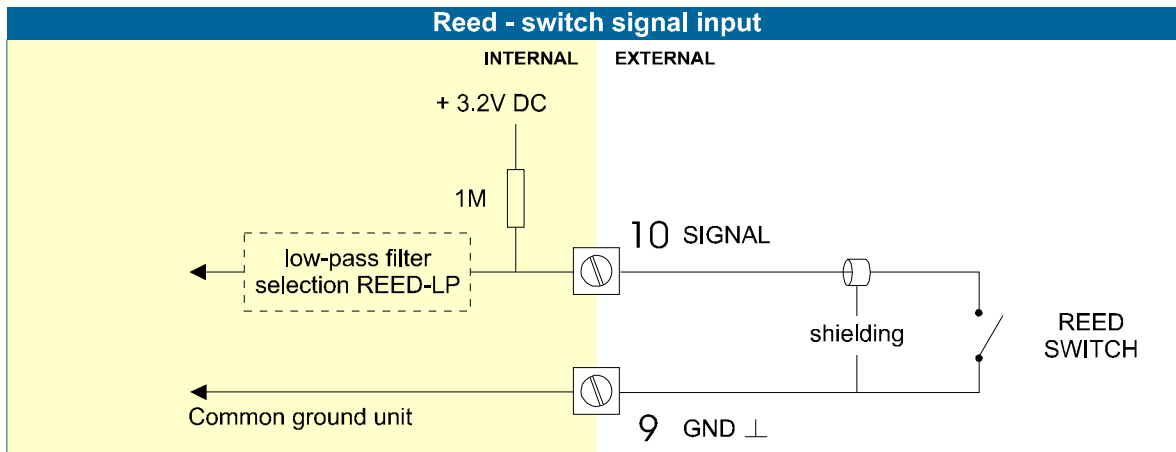

Terminal 12-14; Flowmeter input B:

Exactly as described for the flowmeter A, two basic types of flowmeter signals can be connected for flowmeter input B. Please refer to the descriptions per flowmeter type as describer for flowmeter A. The 9-10-11 do correspond with the terminals 12-13-14.

5. MAINTENANCE

5.1. GENERAL DIRECTIONS



Caution !

- *Mounting, electrical installation, start-up and maintenance of the instrument may only be carried out by trained personnel authorized by the operator of the facility. Personnel must read and understand this Operating Manual before carrying out its instructions.*
- *The ERS may only be operated by personnel who are authorized and trained by the operator of the facility. All instructions in this manual are to be observed.*
- *Ensure that the measuring system is correctly wired up according to the wiring diagrams. Protection against accidental contact is no longer assured when the housing cover is removed or the panel cabinet has been opened (danger from electrical shock). The housing may only be opened by trained personnel.*
- *Take careful notice of the " Safety rules, instructions and precautionary measures " in the front of this manual.*

The ERS does not require special maintenance unless it is used in low-temperature applications or surroundings with high humidity (above 90% annual mean). It is the users responsibility to take all precautions to dehumidify the internal atmosphere of the ERS in such a way that no condensation will occur, for example by placing dry silica-gel sachet in the casing just before closing it. Furthermore, it is required to replace or dry the silica gel periodically as advised by the silica gel supplier.

Battery life-time:

It is influenced by several issues :

- Type of sensor: read chapter 3.2.3. NPN inputs consume more energy than coil inputs.
- Input frequency: the higher the frequency, the shorter the battery life-time.
- Flowrate calculation: the lower number of pulses (SETUP 26) the shorter the battery life-time.
- Analog output signal; be sure that an external power supply is connected or that the function is disabled if not in use; or else it will have a major influence on the battery life-time (SETUP 81).
- Display update: fast display update uses significantly more power; SETUP 61.
- Pulse output.
- Low temperatures; the available power will be less due to battery chemistry.



Note !

Note: *It is strongly advised to disable unused functions.*

Check periodically:

- The condition of the casing, cable glands and front panel.
- The input/output wiring for reliability and aging symptoms.
- The process accuracy. As a result of wear and tear, re-calibration of the flowmeter might be necessary. Do not forget to re-enter any subsequent K-factor alterations.
- The indication for low-battery.
- Clean the casing with soapy-water. Do not use any aggressive solvents as these might damage the coating.

5.2. REPAIR

This product cannot be repaired by the user and must be replaced with an equivalent certified product. Repairs should only be carried out by the manufacturer or his authorized agent.

APPENDIX A: TECHNICAL SPECIFICATIONS

GENERAL

Display	
Type	High intensity reflective numeric and alphanumeric LCD, UV-resistant.
Digits	Seven 17mm (0.67") and eleven 8mm (0.31"). Various symbols and measuring units.
Refresh rate	User definable: 8 times/sec - 30 secs.
Type ZB	Transflective LCD with green LED backlight. Good readings in full sunlight and darkness. Note: only available for safe area applications. Power requirements: 12-24V DC + 10%. Power consumption max. 1 Watt.

Enclosures	
General	Die-cast aluminum or GRP (Glassfibre Reinforced Polyamide) enclosure with Polycarbonate window, silicone and EPDM gaskets. UV stabilized and flame retardant material.
Control Keys	Three industrial micro-switch keys. UV-resistant silicone keypad.
Painting	Aluminum enclosure only: UV-resistant 2-component industrial painting.
Panel-mount enclosures	Dimensions: 130 x 120 x 60mm (5.10" x 4.72" x 2.38") – LxHxD.
Classification	IP65 / NEMA 4X
Panel cut-out	115 x 98mm (4.53" x 3.86") LxH.
Type ERS-RMP	GRP panel-mount enclosure
Type ERS-RMA	Aluminum panel-mount enclosure
Field/wall-mount enclosures	Dimensions: 130 x 120 x 75mm (5.10" x 4.72" x 2.95") – LxHxD.
Classification	IP67 / NEMA4X
Aluminum enclosures	
Type ERS-RMA	Drilling: 2x PG9 – 1x M20.
GRP enclosures	
Type ERS-RMP	Drilling: 2x 16mm (0.63") – 1x 20mm (0.78").
Round meter-mount enclosures	Dimensions: Ø 161 x 87.5mm (5.10" x 2.38") – ØxD.
Classification	IP67 / NEMA 4X
Type ERS-M	Aluminum meter-mount enclosure

Operating temperature	
Operational	-40°C to +80°C (-40°F to +176°F)

Power requirements	
	Lithium battery - life-time depends upon settings - up to 5 years.
	16-30 V DC. Power consumption max. 1 Watt.
	8-30 V DC (also available with battery). Power consumption max. 0.3 Watt.

Sensor excitation	
	Sensor supply voltage: 3.2V DC for pulse signals and 1.2V DC for coil pick-up. Please note: this is not a real sensor supply. Only suitable for sensors with a very low power consumption like coils (sine wave) and reed-switches. Analog sensors type A / U: sensor supply not available.
	With pulse input type P: sensor supply 1.2, 3.2, 8.2V DC - max. 5mA@8.2V DC. With analog input type A / U: as connected power supply voltage (internally linked)

Terminal connections	
Type:	Removable plug-in terminal strip. Wire max. 1.5mm ² and 2.5mm ² (Type PM / PF)

Data protection	
Type	EEPROM backup of all setting. Backup of running totals every minute. Data retention at least 10 years.

Environment	
Electromagnetic compatibility	Compliant ref: EN 61326 (1997), EN 61010-1 (1993).

INPUTS

Flowmeter	
Type P	NPN and Reed-switch.
Frequency	Minimum 0 Hz - maximum 7 kHz for total and flowrate. Maximum frequency depends on signal type and internal low-pass filter. E.g. Reed switch with low-pass filter: max. frequency 120 Hz.
K-Factor	0.000010 - 9,999,999 with variable decimal position.
Low-pass filter	Available for all pulse signals.

OUTPUTS

Analog output	
Function	Transmitting calculated differential or sum flowrate.
Accuracy	10 bit. Error < 0.05% - update 10 times a second. Software function to calibrate the 4.00mA and 20.00mA levels precisely within set-up.
Load	max. 1 kOhm
Type AP	Passive 4-20mA output - output loop powered.

Transistor output(s)	
Pulse output	Max. frequency 60Hz. Pulse length user definable between 7,8msec up to 2 seconds.
Function	Two outputs: scaled pulse output transmitting accumulated total and flow direction indication.
Type OT	Passive transistor output - not isolated. Load max. 50V DC - 300mA.

OPERATIONAL

Operator functions	
Displayed functions	<ul style="list-style-type: none"> • calculated differential or sum total and/or flowrate. • calculated differential or sum accumulated total. • flowrate A • total A • flowrate B • total B • all totals can be reset to zero by pressing the CLEAR-key twice.

Total	
Digits	7 digits.
Units	L, m3, GAL, USGAL, KG, lb, bbl, no unit.
Decimals	0 - 1 - 2 or 3.
Note	total can be reset to zero.

Accumulated total	
Digits	11 digits.
Units / decimals	according to selection for total.

Flowrate	
Digits	7 digits.
Units	mL, L, m3, mg, g, kg, ton, GAL, bbl, lb, cf, rev, no unit
Decimals	0 - 1 - 2 or 3.
Time units	/sec - /min - /hr - /day.

APPENDIX B: PROBLEM SOLVING

In this appendix, several problems are included that can occur when the ERS is going to be installed or while it is in operation.

Flowmeter does not generate pulses:

Check:

- Signal selection SETUP - 71 / 72,
- Pulse amplitude (par. 4.4.3.),
- Flowmeter, wiring and connection of terminal connectors (par. 4.4.3.),
- Power supply of flowmeter (par. 4.4.2.).

Flowmeter generates "too many pulses":

Check:

- Settings for total and Flowrate: SETUP 11-14, 21-27, 31-32 and 41-42.
- Type of signal selected with actual signal generated - SETUP - 71 / 72,
- Sensitivity of coil input - SETUP - 71 / 72 and par. 4.4.3.
- Proper grounding of the ERS - par. 4.4.1.
- Use screened wire for flowmeter signals and connect screen to terminal 9 or 12. (unless connected at sensor)

Analog output does not function properly:

Check:

- SETUP 81 - is the function enabled?
- SETUP 82 / 83: are the flow-levels programmed correctly?
- connection of the external power-supply according to the specification.

Pulse output does not function:

Check:

- SETUP 91 - pulse per "x" quantity; is the value programmed reasonable and will the maximum output be under 60Hz?
- SETUP 92 - impulse width; is the external device able to recognize the selected pulse width and frequency?

Flowrate displays "0 / zero" while there is flow (total is counting):

Check:

- SETUP 22 / 25 and 41 / 42: are the K-factor and time unit correct?
- SETUP 26 / 27: The unit has to count the number of pulses according to SETUP 26 within the time according to SETUP 27. Make sure that 27 is set to 10.0 seconds for example : the result is that the unit has at least 10 seconds time to measure the number of pulses according to SETUP 26.

The pass code is unknown:

If the pass code is not 1234, there is only one possibility left: call your supplier.

ALARM

When the alarm flag starts to blink an internal alarm condition has occurred. Press the "select button" several times to display the 5-digit error code. The codes are:

- 0001: irrecoverable display-data error: data on the display might be corrupted.
- 0002: irrecoverable data-storage error: the programming cycle might have gone wrong: check programmed values.
- 0003: error 1 and error 2 occurred simultaneously

If the alarm occurs more often or stays active for a longer time, please contact your supplier.

INDEX OF THIS MANUAL

accumulated Total	7	low-battery	8
actual settings	32	main-function	10
alarm.....	8	maintenance	27
analog		model.....	19
disable/enable.....	17	negative total output	24
flowrate max.....	17	Notes	32
flowrate min.....	17	Operator level.....	7
<i>output loop powered.</i>	25	pass code	19, 30
tune / calibrate	17	power supply	25
Analog output	25	Problem solving.....	30
Backlight.....	26	pulse output.....	24
battery life time	16, 27	pulse length / period time.....	18
Clear Total	7	pulse per quantity	18
Configuration	8	Pulse-signal NPN/PNP	25
Dimension enclosures	21	rate/Total	7
display		Reed-switch:.....	26
function	15	serial number.....	19
display update	16	SETUP-level	8
flowmeter		subfunction	10
signal.....	16	tagnumber	19
Flowmeter input	25, 26	Technical specification	28
flowrate		terminal connectors	24
calculation	14	total	
decimals.....	13	decimals.....	12
decimals k-factor.....	13, 14	decimals k-factor.....	12, 14
measuring unit	13	k-factor	12, 13, 14
time unit	13	measuring unit	12, 13
Installation	20	version software	19
IP classification.....	20	Voltage selection sensor	24
keys	6		

LIST OF FIGURES IN THIS MANUAL

Fig. 1: Typical application for the ERS	5
Fig. 2: Control Panel.....	6
Fig. 3: Example of display information during process.	7
Fig. 4: Example of low-battery alarm.....	8
Fig. 5: Dimensions Aluminum enclosures.	21
Fig. 6: Dimensions GRP enclosures.	22
Fig. 7: Dimensions ERS-M series Meter mount enclosures.	22
Fig. 8: Grounding aluminum enclosure	23
Fig. 9: Overview of terminal connectors standard configuration ERS and options.....	24
Fig. 10: Overview terminal connectors backlight option.....	Fout! Bladwijzer niet gedefinieerd.

LIST OF CONFIGURATION SETTINGS

SETTING	DEFAULT	DATE :	DATE :
1 - TOTAL A	Enter your settings here		
11 unit	L		
12 decimals	0000000		
13 K-factor	0000001		
14 decimals K-factor	0		
2 - FLOWRATE A			
21 unit	L		
22 time unit	/min		
23 decimals	0000000		
24 K-factor	0000001		
25 decimals K-factor	0		
26 filter	01		
27 period time	1.0 sec.		
3 - TOTAL B			
31 K-factor	0000001		
32 decimals K-factor	0		
4 - FLOWRATE B			
41 K-factor	0000001		
42 decimals K-factor	0		
5 - DISPLAY			
51 function	total		
52 calculate	differential		
53 measurement	bi-directional		
54 stationary flowrate	0 L/ min		
55 stationary total	0 L/hr	/hr	/hr
6 - POWER MANAGEMENT			
61 LCD-new	1 sec.		
62 mode	operational		
7 - FLOWMETER			
71 signal A	npn		
72 signal B	npn		
8 - ANALOG OUTPUT			
81 output	disabled		
82 min. flowrate	0000000		
83 max. flowrate	9999999		
84 cut off percentage	0.0%		
85 tune min - 4mA	0208		
86 tune max - 20mA	6656		
87 filter	01 (off)		
9 - PULSE OUTPUT			
91 impulse width	010 periods		
92 pulse per	0001000		
A - OTHERS			
A4 pass code	0000		
A5 tagnumber	0000000		

