



Badger Meter

M-Series® Mag Meter Model M-5000 Detector

OVERVIEW

The M-Series® Mag Meter model M-5000 detector is the result of years of research and field use in electromagnetic flow meters. Based on Faraday's Law of Induction, these meters can measure well water, wastewater, reclaimed water, chemicals, pharmaceuticals, and bi-directional flow applications that have minimal electrical conductivity.

Designed, developed and manufactured under strict quality standards, the M-Series meter features sophisticated, processor-based signal conversion with accuracies of $\pm 0.50\%$. The wide selection of liner and electrode materials helps ensure maximum compatibility and minimum maintenance over a long operating period.

OPERATION

The flow meter is a stainless steel tube lined with a non-conductive material. Outside the tube, two DC-powered electromagnetic coils are positioned diametrically opposing each other. Perpendicular to the coils, two electrodes are inserted into the flow tube. The energized coils create a magnetic field across the diameter of the pipe.

As a conductive fluid flows through the magnetic field, a voltage is induced across the electrodes. This voltage is proportional to the average flow velocity of the fluid and is measured by the two electrodes. This induced voltage is then amplified and digitally processed by the converter to produce an accurate analog or digital signal. The signal can then be used to indicate flow rate and totalization, or to communicate to remote sensors and controllers.

This technology provides many advantages. With no parts in the flow stream, there is no pressure loss. Also, accuracy is not affected by temperature, pressure, viscosity, density, or flow profile. Finally, with no moving parts, there is little or no maintenance required.

APPLICATION

Because of its inherent advantages over other more conventional technologies, this meter can be used in the majority of industrial flow applications. Whether the fluid is water, highly corrosive, very viscous, contains a moderate amount of solids, or requires special handling, this meter accurately measures fluid flow. Today, magnetic meters are successfully used in industries including pharmaceutical, water and wastewater, and chemical.

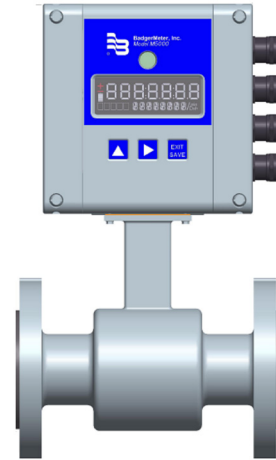

FEATURES

- $\pm 0.50\%$ accuracy independent of fluid viscosity, density and temperature
- Unaffected by most solids contained in fluids
- Pulsed DC magnetic field for zero point stability
- No pressure loss for low operational costs
- Corrosion resistant liners for long life
- Calibrated in state-of-the-art facilities
- Integral and remote signal converter availability
- Optional grounding rings or grounding electrode
- Measurement largely independent of flow profile
- NSF listed

ELECTRODES

When looking from the end of the meter into the inside bore, the two measuring electrodes are positioned 180° apart, at nine o'clock and three o'clock. The M-5000 mag meters have an "empty pipe detection" feature. This is accomplished with a third electrode positioned in the meter between twelve o'clock and one o'clock. If this electrode is not covered by fluid for a minimum five-second duration, the meter will display an "empty pipe detection" condition on the amplifier, and the meter will stop measuring to maintain accuracy. When the electrodes become covered with fluid again, the error message will disappear from the display and the meter will continue measuring.

As an option to using grounding rings, a grounding electrode (fourth electrode) can be built into the meter during manufacturing to assure proper grounding. The position of this electrode is at five o'clock.

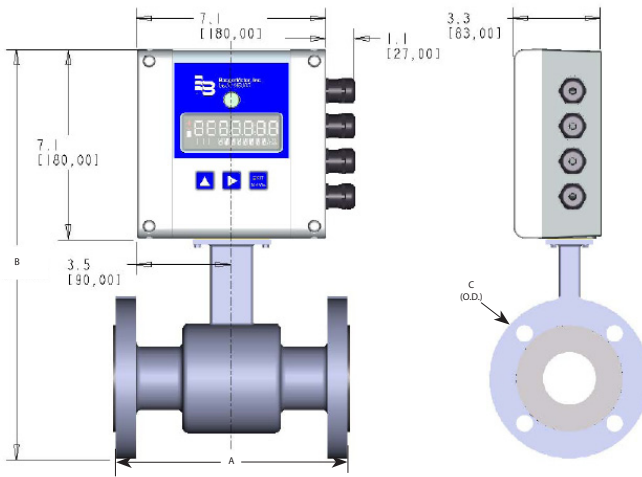

Meter with M-5000 Amplifier

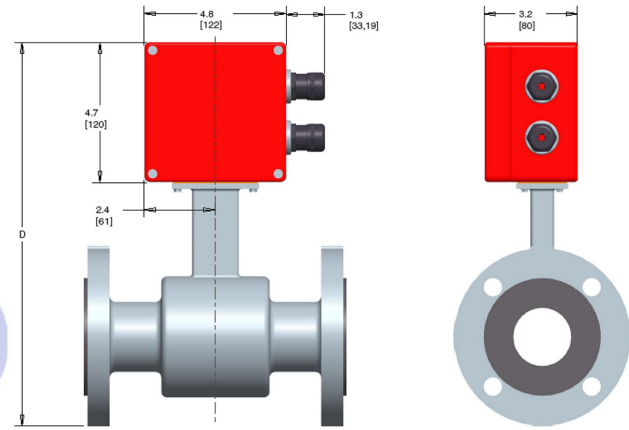

Meter with junction box for remote M-5000 Amplifier

Size		A		B		C		D		Est.Weight with Amplifier		Flow Range			
inch	mm	inch	mm	inch	mm	inch	mm	inch	mm	Lbs	Kg	GPM		LPM	
												Min	Max	Min	Max
1/2	15	6.7	170	13.4	342	3.5	89	13.9	351	17	7.7	0.11	33	0.416	125
3/4	20	6.7	170	13.6	347	3.9	99	14	356	17	7.7	0.2	59	0.75	225
1	25	8.9	225	13.8	352	4.3	108	14.2	361	18	8.8	0.3	93	1.20	350
1 1/4	32	8.9	225	14.6	372	4.6	117	15	381	20.3	9.2	0.5	152	2.00	575
1 1/2	40	8.9	225	14.8	376	5.0	127	15.2	386	22	10	0.8	239	3.00	900
2	50	8.9	225	15.3	389	6.0	152	15.7	398	26	11.7	1	373	4.70	1400
2 1/2	65	11.0	280	16.5	420	7.0	178	16.9	429	35	15.7	2	631	8	2400
3	80	11.0	280	16.7	426	7.5	191	17.2	435	38	17.1	3	956	12	3600
4	100	11.0	280	17.8	452	9.0	229	18.2	461	49	22.1	5	1493	19	5600
5	125	15.8	400	19	484	10.0	254	19.4	493	60	27.1	8	2334	30	8800
6	150	15.8	400	20	510	11.0	279	20.4	519	71	32.1	11	3361	40	12,700
8	200	15.8	400	21.9	558	13.5	343	22.9	583	95	43.1	20	5975	75	22,600
10	250	19.7	500	26.2	677	16.0	406	26.6	676	130	59.1	30	9336	120	35,300
12	300	19.7	500	28.3	720	19.0	483	28.7	729	219	99.3	45	13,444	170	50,800
14	350	23.6	590	30.2	768	21.0	533	30.7	779	287	130.2	60	18,299	230	69,200
16	400	23.6	590	33.1	842	23.5	597	33.5	851	354	160.9	80	23,901	300	90,400
18	450	23.6	590	34.4	876	25.0	635	34.9	885	409	185.3	100	30,250	380	114,000
20	500	23.6	590	337.6	955	27.5	699	38	964	502	228.3	125	37,346	470	140,000
22	550	23.6	590	39	991	29.5	749	39.4	1000	532	241.3	150	45,188	570	170,000
24	600	23.6	590	41.6	1057	32.0	813	42	1066	561	255.3	180	53,778	680	200,000

SPECIFICATIONS - Detector

Flow Range: 0.328 to 32.8 fps (0.1 to 10 m/s)

Sizes: 1/2-inch to 24 inches (15 mm to 600 mm)

Min. Conductivity: ≥ 20 micro siemens/cm

Accuracy:

± 0.50% of rate for velocities greater than 1.64 ft/s (0.50 m/s)

± 0.008 ft/s (± 0.0025 m/s) for velocities less than 1.64 ft/s (0.50 m/s)

Electrode Materials: Standard: Alloy C

Optional: 316 stainless steel

Liner Material: PTFE 1/2 inch to 24 inches, hard rubber 1 inch to 24 inches

NSF Listed: Models with hard rubber liner 4-inch size and larger; PTFE liner (all sizes).

Fluid Temperature:

With Remote Amplifier:

PTFE 311°F (155°C)

Hard Rubber 178°F, (80°C)

With Meter-Mounted Amplifier:

PTFE 212°F (100°C)

Hard Rubber 178°F, (80°C)

Pressure Limits:

Maximum allowable non-shock pressure and temperature ratings for steel pipe flanges, according to American National Standard ANSI B16.5. Examples:

150-pound flanges, rated 285 PSI at ambient temperature; 300-pound flange rated 740 PSI at ambient temperature.

Coil Power: Pulsed DC

Ambient Temperature: -4°F to 140°F (-20°C to 60°C)

Pipe Spool Material: 316 stainless steel

Meter Housing Material: Carbon steel welded

Flanges: Carbon steel - Standard (ANSI B16.5 Class 150 RF) 316 stainless steel (optional)

Meter Enclosure Classification: NEMA 4X (IP66)

Optional: Submersible NEMA 6P (remote amplifier required)

Junction Box Enclosure Protection:

(for remote amplifier option) Powder-coated die-cast aluminum, NEMA 4 (IP65)

Cable Entries: 1/2-inch NPT Cord Grip

Optional Stainless Steel Grounding Rings:

Meter Size Thickness (of one ring)

Up through 10 inches .135 inch

12 to 24 inches .187 inch

M-Series is a registered trademark of Badger Meter, Inc.

Copyright 2010, Badger Meter, Inc. All rights reserved.



Due to continuous research, product improvements and enhancements, Badger Meter reserves the right to change product or system specifications without notice, except to the extent an outstanding contractual obligation exists.