

FREEFLOW™

P-Type Flow Transmitter

Installation, Operation & Maintenance Manual



www.lakemonitors.com

Lake Monitors 8809 Industrial Drive, Franksville, WI 53126
P: (800) 850-6110 (262) 884-9800 F: (262) 884-9810



www.lakemonitors.com

Materials of Construction	
End Ports	PVC
Wedge Element	PVC
Pressure Sensor	Polyetherimide
Electrical Enclosure	Polycarbonate
Performance	
Measuring Accuracy:	±2% of full-scale
Repeatability:	±.5% of full-scale
Flow Measuring Range:	5-15 GPM (19-57 LPM)
Turn Down Ratio (All Ranges):	8:1
Maximum Operating Pressure:	125 PSIG (8.6 bar)
Maximum Operating Temperature:	170°F (76°C)
Pressure Differential:	See graph on page 11.
Filtration Requirements:	200 Micron minimum
Electronic Specifications	
Electronic Output:	0-5/0-10 Vdc (standard), 4-20 mA (optional)
Power Requirements:	12-35 Vdc
Flow Measuring Range:	5-15 GPM (19-57 LPM)
Maximum Current Consumption:	25 mAdc
Maximum Load Resistance:	1000 Ω
Maximum Transmission Distance:	≤ 200 feet
Resolution:	12-bit
Response Time:	500 mS 10% to 90% (step change)
Protection:	Short circuit, transient & reverse polarity

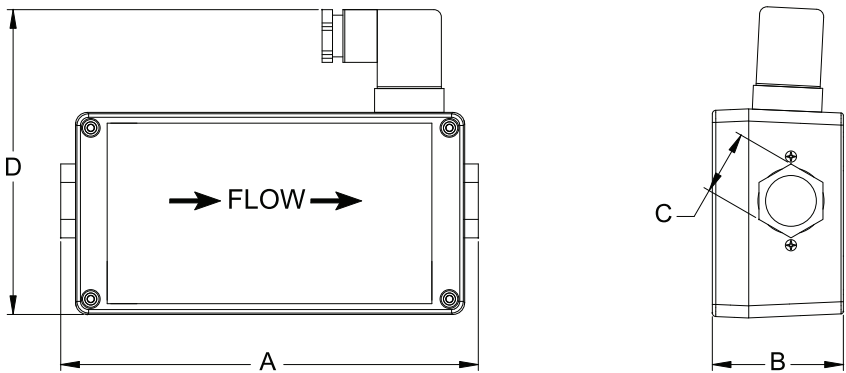
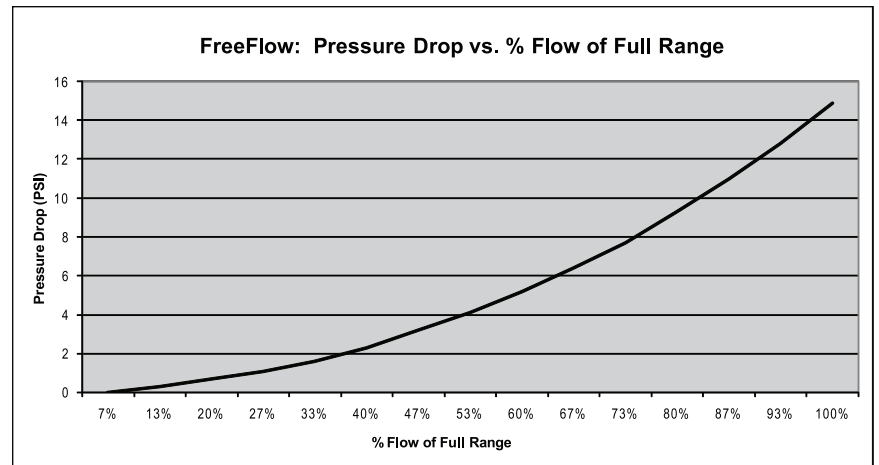

DIM	3/8" Female NPTF	1/2" Female NPTF	3/4" Female NPTF
A	6-7/8" (175mm)	6-7/8" (175mm)	7-1/2" (191mm)
B	2-7/32" (57mm)	2-7/32" (57mm)	2-7/32" (57mm)
C	1-3/32" (28mm)	1-3/32" (28 mm)	1-5/16" (34 mm)
D	5-1/4" (134mm)	5-1/4" (134mm)	5-1/4" (134mm)

acceptable time period. The system should be stabilized in time to prevent premature wear, clogging or damage to meter components.

Contamination Sources

Fresh Fluid

When fresh fluid is stored in holding tanks, it may be contaminated with scale or particulate from inside the tank. To prevent this type of contamination, be sure to filter fresh fluid before adding to the system.

New Machinery Contamination

When building new machines, a certain amount of built-in contamination is unavoidable. Typical built-in contamination consists of dust, dirt, chips, fiber, and sand, flushing solutions, moisture, weld splatters and pipe sealants. Flushing the system before operation can reduce contamination, but cannot eliminate it totally. Unless the system is flushed at a high velocity, some contamination will not be dislodged until the system is in operation. System contamination can cause fluid component malfunction.

Environmental Contamination

When performing routine maintenance, the system's fluid is commonly exposed to environmental contamination. Exercise caution during routine maintenance to prevent this type of contamination. Be sure to change breather filter and systems air filter regularly.

Self-Generation Contamination

Self-generated contamination is a product of wear, cavitation, fluid breakdown and corrosion. Systems that are carefully flushed, maintained, and have fresh fluid added, mainly have self-generated contamination. In this case, proper filtration can prevent fluid component malfunction.

Installation

Basic Application Information

The FreeFlow flow meter can be installed directly in the fluid line without flow straighteners or special piping. The meter's primary use is for water measurement applications.

- 1) The flow metering element and plumbing connectors are made from PVC permitting use with a variety of media. Use of mild detergent to clean the meter body is encouraged to prevent damaging the label or associated components.
- 2) The meter may be mounted in the most convenient location, in any orientation to allow easy access for installation and maintenance.
- 3) The FreeFlow meter should NOT be mounted near hot pipes or equipment which can cause damage to the device. The maximum temperature rating of 170°F (76°C) must be observed for ambient conditions as well as the fluid stream.
- 4) The FreeFlow meter should be mounted in a manner such that piping misalignment or other system components can not exert force or produce a bending moment on the pressure vessel.
- 5) To retain accuracy and repeatability internal passages are closely toleranced and require filtration of at least 200 micron.

Warning and Precautionary Areas

- 1) The pressure vessel of the flow meter and its associated components are made of Polyvinylchloride. Polyvinylchloride can be safely cleaned with soap and water. However, many other cleaning agents can damage Polyvinylchloride, causing cracking or crazing. If you are unsure of your cleaning agent, refer to a compatibility guide for PVC.
- 2) When installing FreeFlow meters onto threaded pipe caution should be taken not to over tighten the pipe connections or introduce torque on the main body of the meter. The meter main body may rupture if over-tightened.
- 3) The FreeFlow meter should not be used in systems where the assembled piping is not supported. Externally applied piping forces may cause the meter to rupture or malfunction.

- 4) Operating Temperature: In standard meters, several components have a maximum temperature rating of 170°F (76°C).
- 5) Operating Pressure: Meters should not be used over 10% of the operating pressure rating.
- 6) Pipe Sealer: Care should be taken when choosing a pipe sealing method. The use of pipe sealing pastes is often discouraged when sealing plastic fittings.

Basic Installation Instructions

The meters are mounted in-line and provide an electrical output that is proportional to flow rate. The meters can be mounted in a vertical or horizontal position as long as the fluid is flowing in the direction of the arrow on the enclosure. No straight pipe is required before or after the meter. In fact, 90° elbows can be installed on both ends without any noticeable flow variation. When installing a meter, "Thread Seal Tape" is the preferred means to seal the pipe threads. If tape is used, be sure to leave 1/8" (3 mm) of pipe thread exposed on end of pipe. Position filter in front of meter and in a location that allows easy access for routine maintenance. Refer to "Warnings and Precautionary Areas" for additional information.

Installation Dos & Don'ts:

To obtain satisfactory operation from the flow meter, the following points should be considered:

DO:

- place throttling valves at the outlet of the meter
- use pipe tape on the connections
- install solenoid valves at meter outlet (as far downstream as possible)
- mount in any orientation: vertical, horizontal or upside down

DO NOT:

- place meter in non-aligned piping
- use paste thread sealer
- over-flow the meter by more than 150% of maximum reading
- operate at pressures and temperatures greater than specified
- provide insufficient power for the excitation of the meter

Operation

Operating Principle

The FreeFlow Series is a line of unique flow meters which combine the simplicity of a segmented wedge differential producer with a precise wetted micro pressure sensor. The meters are self contained and all of the wetted components are isolated from the electronics. Running through the enclosure is the segmented wedge metering element. The metering element is devised in a manner which provides minimal restriction to the flow and enables a design with no moving parts. As flow increases, the pressure differential across the metering element increases, providing for a predictable response of calibrated output.

Scaling the Electronics

All FreeFlow meters come from the factory 100% calibrated and ready for use. The receiving device will generally need to be scaled to reflect the correct FSRV (full scale range value) of the calibration. Performing this task requires that the peak output of device is correlated to the range of FSRV of calibration ordered. Refer to the manufacturer specific documentation for the receiving device in question.

Effect of Varying Fluid Properties

Standard meters are calibrated for WATER with a specific gravity of 1.0. The segmented wedge meter is affected by changes in density as are most other meters based upon this principle. The indicated flow reading will read high for heavier fluids and low for lighter fluids. An alternate calibration can be applied to the meter for additional costs.

Contamination & Filtration

Recommended Filtration

The manufacturer recommends system filtration of at least 200 micron filter or screen. Some systems may require a magnetic filter. **IMPORTANT:** Meter damage caused by excessive contamination is not covered under warranty.

Stabilized Contamination

The goal of filtration is to create effective protection from system contamination. Proper filtration stabilizes contamination to allow fluid components to function properly. A fluid system is considered stabilized when, "contamination in" equals "contamination out". Proper filtration must reduce initial contamination to a stabilized level within an

4-20 mA Configurations

Device Settings: (Refer to Table 1 for details of this output option.)

- 1) Using a small flat blade screwdriver, set the 10-position selector switch to position 0.
- 2) Verify that the 2-position jumper JP1 is shunting pins 2 & 3.
- 3) Connect the output connector to position B, as shown in Figure 3.

Table 3: (Field configurable settings for 4-20mA output option)

Configurable Control:	Setting:
10 position selector switch	Position 0
2 position jumper JP1	Pins 2 & 3 shunted
Output connector	Position B

Input Voltage:

The supply voltage must be between 12 and 35 VDC. The maximum resistance that may be placed within the current loop is given by the following formula:

$$R_{max} = 50(V_s - 12)$$

R_{max} = the maximum resistance that may be placed in the current loop (Ω)
 V_s = the value of the supply voltage (VDC)

NOTE: Although the signal conditioning circuit does have integral over-current protection, manufacturer suggests that the circuit be protected with a 0.25 amp fuse.

- 1) Connect the positive DC power source (+12 to +35 VDC) to terminal # 1 on the DIN connector or the red wire on the pigtail.
- 2) Connect terminal #2 of the DIN connector or the black wire from the pigtail to the positive current input on the receiving device.
- 3) If the power source does not originate from the receiving device, the negative side of the power supply must be connected to the signal ground of the receiving device.
- 4) If the transmitter is operating properly, the green LED on the signal conditioning board will illuminate dimly at zero flow and will increase in intensity as flow increases.

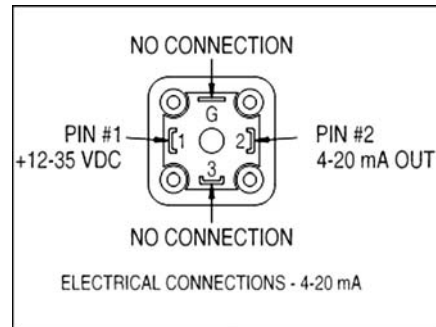

Figure 3

Configuration / Operating Modes

Field Configurable Outputs

The FreeFlow meter can be field configured to offer a variety of output protocol signals. Possible outputs protocol options are 4-20mA, 0-5Vdc and 0-10Vdc. The following steps must be taken prior to making any field configuration changes.

- 1) Fluid flow to the device should be shut off; the device must not be under pressure.
- 2) The device should be disconnected from power prior to any field calibration.
- 3) All safety protocols for the environment in which the device is installed must be considered; remove the device from the installation if needed.
- 4) Removing the cover will reveal the internal signal conditioning circuitry and the field configurable controls. Figure 1 illustrates the field configurable attributes of the device which shall be referenced in subsequent sections of this manual.

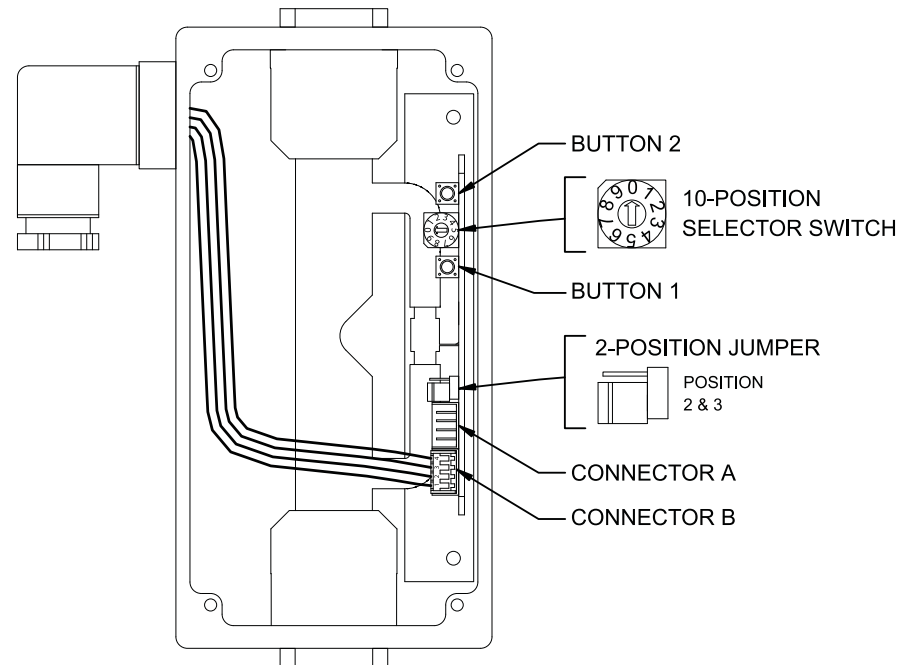

0-5 Vdc Configurations

Device Settings: (Refer to Table 1 for details of this output option.)

- 1) Using a small flat blade screwdriver, set the 10-position selector switch to position 1. 
- 2) Verify that the 2-position jumper JP1 is shunting pins 2 & 3.
- 3) Connect the output connector to position A, refer to Figure 1.

Table 1: (Field configurable settings for 0-5Vdc output option)

Configurable Control:	0-5 Vdc Setting:
10 position selector switch	Position 1
2 position jumper JP1	Pins 2 & 3 shunted
Output connector	Position A

Electrical Connection:

Refer to Figure 1

Input Voltage:

The supply voltage must be between 12 and 35 VDC.

NOTE: The input impedance (resistance) of the receiving device must not be lower than 1000 Ω or non-linearity may result. Lower impedances will not damage the transmitter.

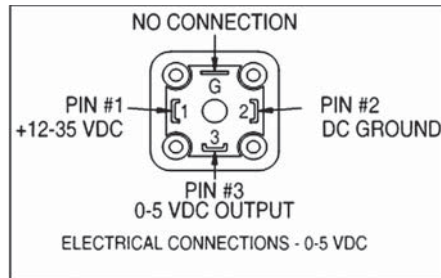

Figure 1

- 1) Connect the positive voltage source (+12 to +35 VDC) to terminal #1 of the DIN connector or the red wire on the pigtail.
- 2) Connect terminal #2 of the DIN connector or the black wire from the pigtail to the negative side of the DC voltage source.
- 3) Connect terminal #3 of the DIN connector or the white wire from the pigtail to the 0-5 VDC input of the receiving device.
- 4) If the power source does not originate at the receiving device, a wire will need to be connected between the negative side of the voltage source and the signal ground of the receiving device.
- 5) If the circuit is operating correctly, the green LED on the circuit board will illuminate brightly when power is applied to the unit.

0-10 Vdc Configurations

Device Settings: (Refer to Table 2 for details of this output option.)

- 1) Using a small flat blade screwdriver, set the 10-position selector switch to position 2. 
- 2) Verify that the 2-position jumper JP1 is shunting pins 2 & 3.
- 3) Connect the output connector to position A, refer to Figure 1.

Table 2: (Field configurable settings for 0-10Vdc output option)

Configurable Control:	0-10 Vdc Setting:
10 position selector switch	Position 2
2 position jumper JP1	Pins 2 & 3 shunted
Output connector	Position A

Electrical Connection:

Refer to Figure 2

Input Voltage:

The supply voltage must be between 12 and 35 VDC.

NOTE: The input impedance (resistance) of the receiving device must not be lower than 1000 Ω or non-linearity may result. Lower impedances will not damage the transmitter.

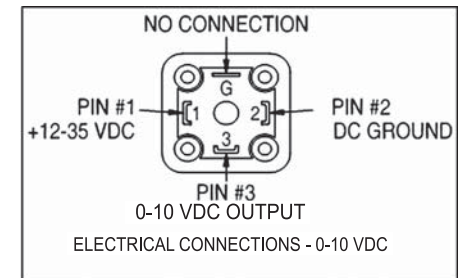

Figure 2

- 1) Connect the positive voltage source (+12 to +35 VDC) to terminal #1 of the DIN connector or the red wire on the pigtail.
- 2) Connect terminal #2 of the DIN connector or the black wire from the pigtail to the negative side of the DC voltage source.
- 3) Connect terminal #3 of the DIN connector or the white wire from the pigtail to the 0-10 VDC input of the receiving device.
- 4) If the power source does not originate at the receiving device, a wire will need to be connected between the negative side of the voltage source and the signal ground of the receiving device.
- 5) If the circuit is operating correctly, the green LED on the circuit board will illuminate brightly when power is applied to the unit.