



### FLOW METER LIMITED WARRANTY

Meters are warranted against defects in materials and workmanship to the original user for a period of thirteen (13) months from the date of factory shipment, provided the meter is installed, operated and maintained in accordance with King Instrument Company's instructions and recommendations.

This warranty does not apply if failure is caused or contributed to by any of the following: improper handling, improper storage, abuse, unsuitable application of the product, lack of reasonable and necessary maintenance, use exceeding suggested pressure and temperature maximums, improper packaging for return, or repairs made or attempted to be made by anyone other than King Instrument Company, Inc.

KING INSTRUMENT COMPANY, INC. MAKES NO WARRANTY AS TO THE FITNESS OF ITS PRODUCTS FOR SPECIFIC APPLICATIONS.

This warranty is valid for the original end-user only and does not apply to products that have been damaged or modified. This warranty is non-transferrable and is limited to replacement or repair. The liability of King Instrument Company arising out of its supply of the products, or their use, shall not in any case exceed the cost of correcting defects in the products as set forth above.

THIS WARRANTY IS A LIMITED WARRANTY AND SHALL BE IN LIEU OF ANY OTHER WARRANTIES, EXPRESSED OR IMPLIED, INCLUDING BUT NOT LIMITED TO ANY IMPLIED WARRANTY OR MERCHANTABILITY OR FITNESS FOR A PARTICULAR PURPOSE. THERE ARE NO OTHER WARRANTIES WHICH EXIST BEYOND THE DESCRIPTION OR FACE HEREOF.

IN NO EVENT SHALL KING INSTRUMENT COMPANY BE LIABLE FOR LOSS OF PROFITS, INDIRECT, CONSEQUENTIAL OR INCIDENTAL DAMAGES.

Products should be returned, prepaid, to King Instrument Company, Inc. with proof of purchase. Call factory for Return Merchandise Authorization (RMA) number and return instructions.

### THIS IS IMPORTANT INFORMATION. READ IT CAREFULLY BEFORE BEGINNING WORK.

- 1) Inspect meter for damage that may have occurred during shipping. Report any damage to the container to the freight carrier immediately.
- 2) Remove any shipping material placed in the inlet and outlet of the meter. (This is done to prevent damage caused by movement of the float during shipping)
- 3) Make sure your pressure, temperature, fluid and other requirements are compatible with the meter and components.
- 4) Select a suitable location for installation to prevent excess stress on the meter which may result from:
  - a) Misaligned pipe.
  - b) The weight of related plumbing.
  - c) "Water Hammer" which is most likely to occur when flow is suddenly stopped as with quick closing solenoid operated valves. (If necessary, a surge chamber should be installed. This will also be useful in pressure start-up situations.)
  - d) Thermal expansion of liquid in a stagnated or valve isolated system.
  - e) Instantaneous pressurization which will stress the meter and could result in tube failure.
- 5) Handle the meter carefully during installation.
  - a) Use an appropriate amount of teflon tape on external pipe threads before making connections. Do not use paste or stick type thread sealing products.
- 6) Install the meter vertically with the inlet port at the bottom.
- 7) Meters with stainless steel fittings will support several feet of pipe as long as significant vibration or stress resulting from misaligned pipe are not factors.
- 8) Meters used in gas service should have suitable valves plumbed in at the inlet and outlet of the meter. These valves should be no more than 1-1/2 pipe diameters from the meter ports. The valve at the outlet should be used to create back pressure as required to prevent float bounce. It should be set initially and then left alone. The inlet valve should be used for throttling purposes. Depending on the installation, valves may not be essential, but they are most useful in many installations. Remember: To get a correct reading of flow in gas service, it is necessary to know the pressure right at the outlet of the meter (before the valve).

**NOTE:** In closed thermal transfer or cooling systems, install the meter in the cool side of the line to minimize meter expansion and contraction and possible fluid leaks at the threaded connections.

## ADDITIONALLY

- 7750 Series meters are designed for vertical installation only. (Inlet at bottom, Outlet at top)
- Do not remove or adjust the screws on the back of the indicator housing.

These screws were positioned during factory calibration and represent the zero adjustment. If the pointer is set on zero, proceed with installation. If the pointer is not set at zero, follow these steps:

- 1) Remove front cover with gasket and shield from indicator housing.
- 2) Loosen set screw at the base of the pointer hub.
- 3) Reposition pointer to zero line.
- 4) Tighten set screw with a 1/16" allen wrench by holding the pointer hub and gently tightening the set screws.
- 5) Replace front cover with gasket and shield on indicator housing.

## CAUTION

Zero is factory set when meter is calibrated. DO NOT loosen screws that fasten indicator housing to meter body. If indicator housing is moved, the meter will need to be calibrated.

Max Non-Shock Pressure and Temperature		
Temp	Stainless Steel Flange Class	
°F	150# psig	300# psig
200	225	600
300	200	540
400	180	515

Note: The maximum ambient temperature for the indicator housing is 400°F

## CAUTION

- Do not loosen nuts that fasten indicator housing to metering tube. If the relationship of meter tube and indicator housing are changed, meter must be calibrated.
- Serious property damage and great personal injury could occur as the result of a meter misused or used in an unsuitable application.

## CLEANING

Carefully remove the flowmeter from piping system. Remove the inlet float stop and outlet float stop and withdraw float from top of meter. All necessary instrument components are now fully accessible for cleaning with a bottle brush and appropriate mild soap solution\*. Before the meter is reassembled, inspect all parts for damage.

To reassemble, carefully guide the magnetic float back into the tube. Reinstall and tighten inlet float stop and outlet float stop. Reinstall the instrument into the plumbing system.

\*Do not use cleaning agents that will damage float or tube.

Meters should be cleaned with a mild soap solution. This will be an effective cleaner of rust stains. Caution must be used so that materials of construction are not damaged by cleaning solutions. Hard water deposits can be removed with 5% acetic acid solution (vinegar).

## REPAIR

7750 meters that require repair should be sent to the factory. Please call for a Return Merchandise Authorization (RMA) number and return instructions.

## WARNING

Pressure and temperature ratings are based on a study of the engineering data for particular materials used in construction and on the design of individual models. This information is supplemented by destructive test results. Meters with stainless enclosures must never be operated without shields securely in place. Meters exposed to difficult environments such as those created by certain chemicals, excessive vibration or other stress inducing factors could fail at or below the suggested maximums. Never operate meters above pressure and temperature maximums. It is strongly recommended that all meter installations utilize an appropriate pressure relief valve and/or rupture disc. The pressure settings and locations of these devices should be such that meters cannot be over pressurized. Meter failure could result in damage to equipment and serious personal injury. Always use suitable safety gear, including OSHA approved eye protection when working around meters in service. We are happy to pass along chemical compatibility information that has been published by the manufacturer's of raw materials used in our products; however, this information should not be construed as a recommendation made by King Instrument Company, Inc. for a specific application.

## OVERALL DIMENSIONS

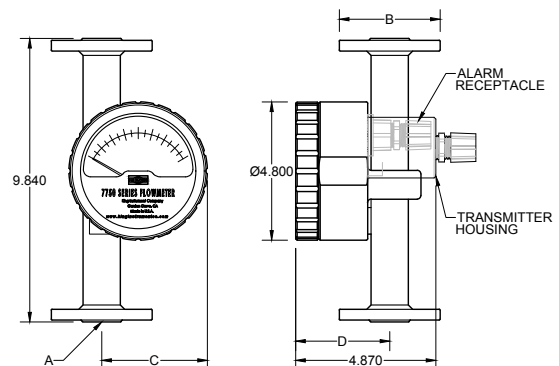

Dim.	A*	B**	C	D
705-712	1/2"	3.50/3.75	3.67	3.27
715-720	1"	4.25/4.88	3.92	3.56

\*Flange Connection \*\*150#/300#

## 7750 SERIES ASSEMBLY PARTS LIST:

1. Shield Retainer
2. Shield Gasket
3. Shield
4. Shield Retainer O-Ring
5. Indicator Housing/Meter Tube Assembly
6. Pointer Needle Set Screw
7. Float
8. Float Stop Lock Washer
9. Outlet Float Stop
10. Inlet Float Stop

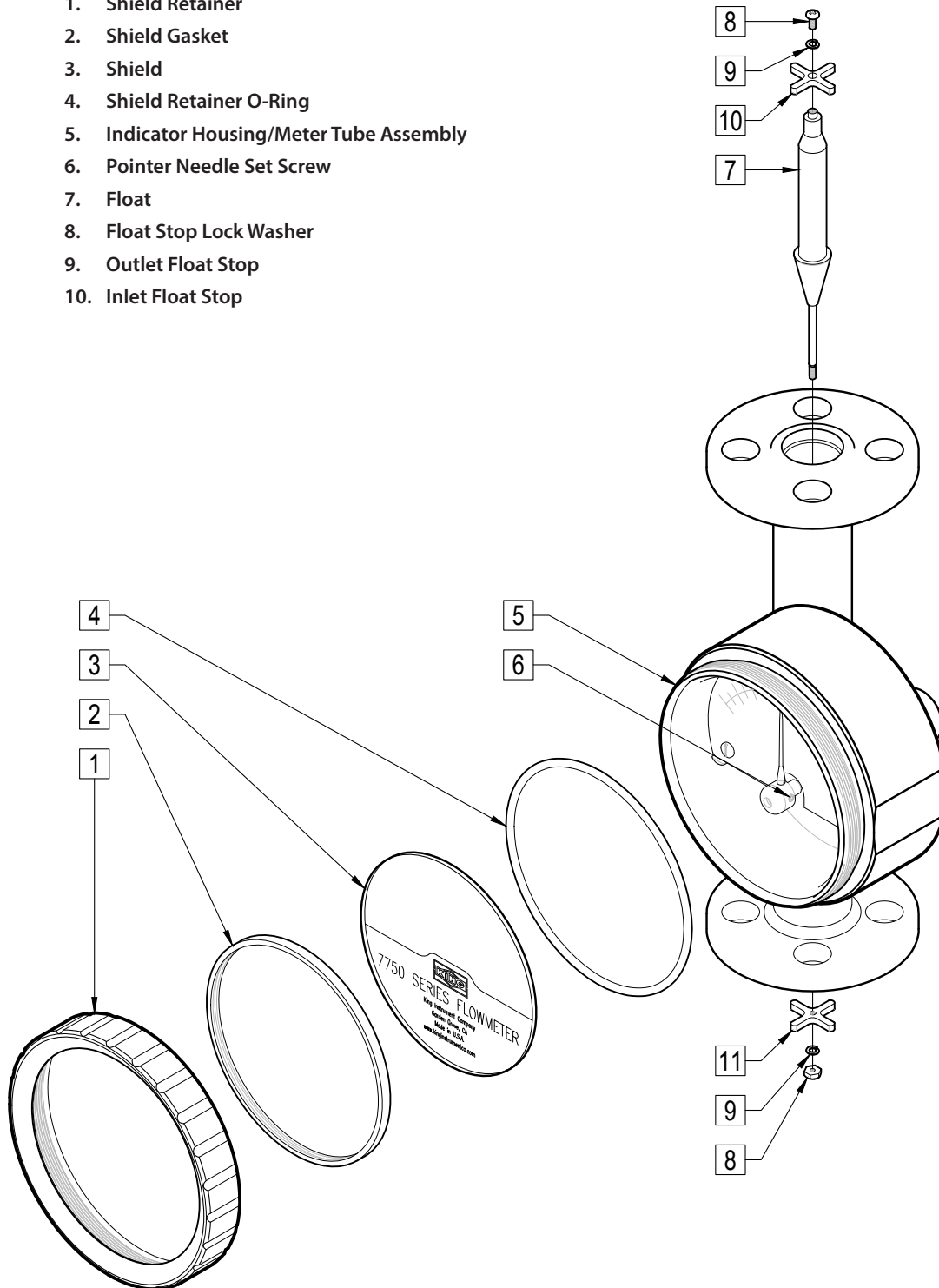

## 7750 SERIES INDUCTIVE SLOT SENSOR

All 7750 Series flowmeters may be fitted with one or two inductive slot sensors. Inductive slot sensors are 2-wire, DC, low current devices and are designed to be used with a remote barrier / switch isolator capable of powering the sensor and providing the desired switching option(s). Barrier / switch isolators are available with 220VAC, 110VAC or 24VDC supply voltage requirements, contain single pole double throw (SPDT) relays, and are DIN rail mountable. (Only 24VDC units are actually powered by the rail.) See barrier / switch

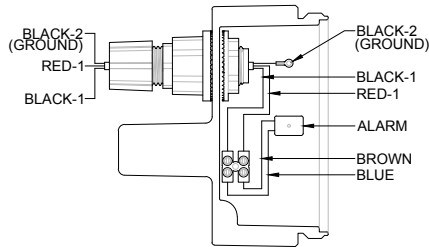

**SINGLE ALARM WIRING DIAGRAM**

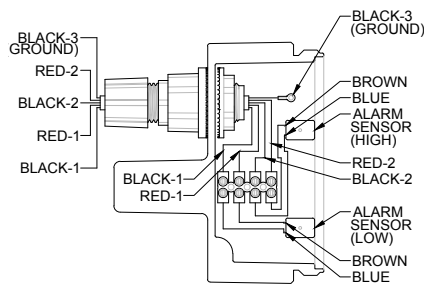

**DUAL ALARM WIRING DIAGRAM**

### 7750 SERIES ASSEMBLY INDUCTIVE SLOT SENSOR PARTS LIST:

1. Shield Retainer
2. Shield and Gasket
3. Indicator Housing/ Meter Tube Assembly
4. Pointer Hub and Pointer Needle
5. Alarm Nut
6. Alarm Sensor Bracket

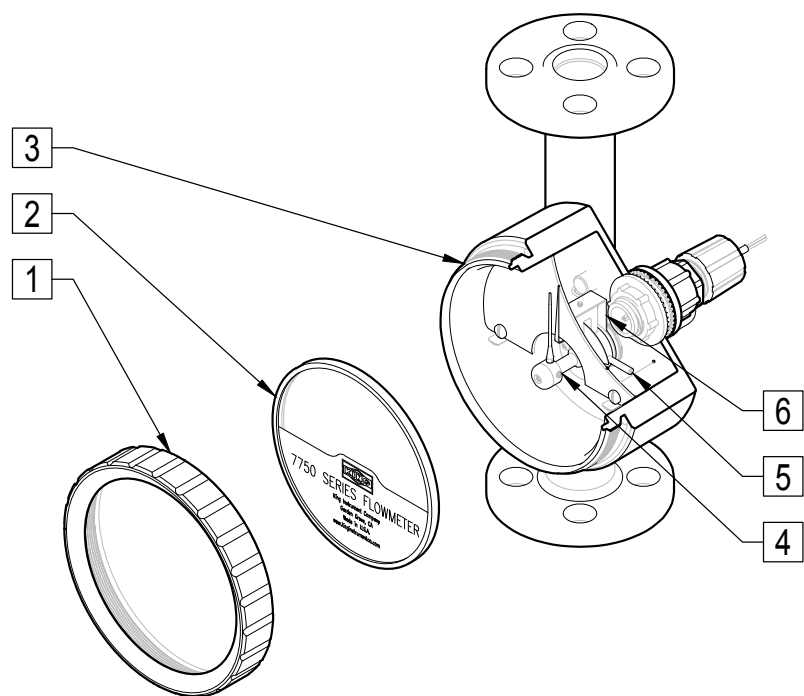

## INDUCTIVE SLOT SENSOR-ELECTRICAL SPECIFICATIONS

<b>TYPE:</b>	Inductive
<b>SUPPLY VOLTAGE:</b>	5-25V DC (Switch Isolator)
<b>OUTPUT:</b>	NAMUR
<b>OUTPUT LOAD CURRENT:</b>	<= 1mA-Float Present >= 3mA (15mA Max.)-Float Absent
<b>SWITCHING FREQUENCY:</b>	2KHZ
<b>HOUSING RATING:</b>	IP67
<b>WIRING:</b>	2 Conductor, NAMUR POS=BROWN / NEG=BLUE TERMINALS: #1=POS / #2=NEG
<b>PEPPERL+FUCHS</b>	UL: General Purpose
<b>SENSOR APPROVALS</b>	CSA: General Purpose

## SETTING ALARM TRIGGER POINTS

- 1) Unscrew the SHIELD RETAINER to remove the SHIELD and GASKET.
- 2) Remove the SHIELD and GASKET.
- 3) Carefully loosen the ALARM NUT. (Loosen just enough to rotate the ALARM SENSOR BRACKET).
- 4) Carefully rotate the ALARM SENSOR BRACKET to the desired alarm set point. If the meter has DUAL ALARMS, set the LOW ALARM set point and then the HIGH ALARM set point.
- 5) Tighten the ALARM NUT.
- 6) Replace the SHIELD and GASKET, secure with the SHIELD RETAINER.

## 7750 SERIES ASSEMBLY INDUCTIVE SLOT SENSOR

## 7750 SERIES 4-20 mA TRANSMITTER

To convert the measured flow into a 4-20 mAdc signal, an angle of rotation transmitter is mounted to the indicator. This device is factory calibrated to ensure accuracy and should only be adjusted by King Instrument Company.

## 4-20 MA TRANSMITTER SPECIFICATIONS

POWER SUPPLY:	12-33V DC
MAXIMUM CURRENT CONSUMPTION:	40 mA
TEMPERATURE LIMITS:	-13°F to 158°F (-25°C to 70° C)
OUTPUT:	4 to 20 mAdc
ACCURACY:	<=0.5%
LINEARITY:	+/- 0.4%
INFLUENCE FROM BEARING:	+/- 0.1%
TEMPERATURE INFLUENCE (AMBIENT):	+/- 0.03% per degree C
POWER SUPPLY INFLUENCE:	+/- 0.1%
LOAD RESISTANCE INFLUENCE:	+/- 0.03% at R max.

## ELECTRICAL CONNECTIONS:

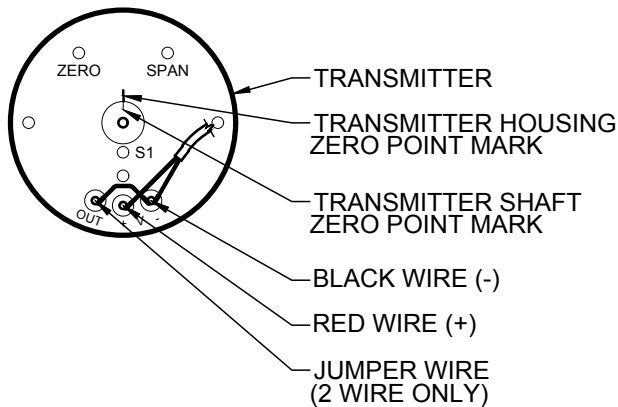

## TRANSMITTER - REAR VIEW

- ZERO: POTENTIOMETER P1 FOR ZERO POINT
- SPAN: POTENTIOMETER P2 FOR MEASURING RANGE AND VALUE
- S 1: SWITCH FOR REVERSING ROTATION (NOT APPLICABLE)

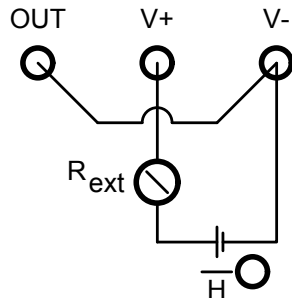

## 2-WIRE CONNECTION

$R_{ext}$ : EXTERNAL RESISTANCE =

$\frac{\text{POWER SUPPLY (V)} - 12\text{V}}{\text{OUTPUT SIGNAL (mA)}}$

H: DC POWER SUPPLY (12V-33V)