

PZ12-LP Low Profile Ultrasonic Sensor

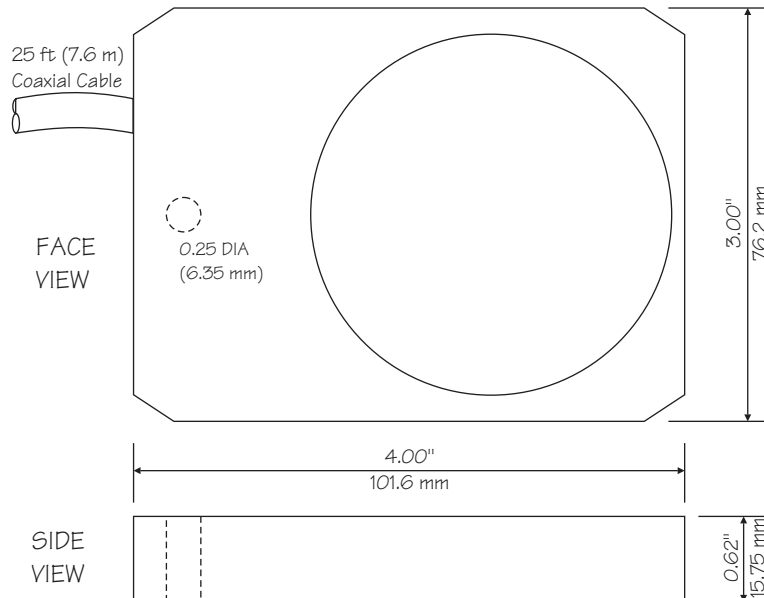

SPECIFICATIONS:

Maximum Range:	12 ft (3.66 m)
Minimum Range (deadband):	8" (203.2 mm)
Operating Frequency:	92 KHz
Beam Angle:	8°
Operating Temperature:	-40° To 150°F (-40° To 65°C)
Temperature Compensation:	Automatic, Continuous
Max. Operating Pressure:	20 Psi (1.35 Bar)
Sensor Face:	PVC
Sensor Body:	PVC
Mounting:	MB12 Stainless Steel Mounting Bracket (included)
Cable Length:	25 Ft. (7.6 M) continuous RG62AU coaxial Optional 50 ft. (15 m) continuous
Max. Cable Length:	500 ft. (152 m) RG62AU coaxial (splice)
Hazardous Rating:	CSA rated Intrinsically Safe Class I, Groups C,D, Class II, Groups E,F,G with optional Intrinsic Safety Barrier.

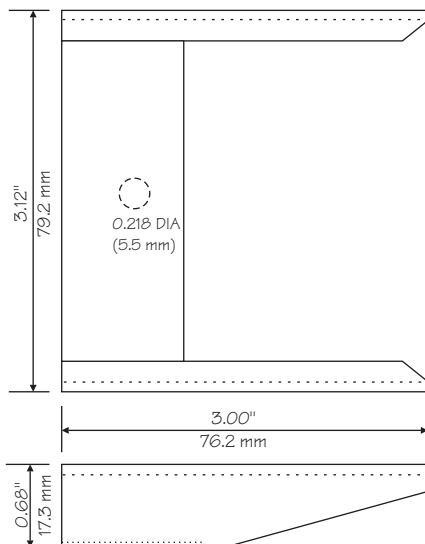

MB12 - MOUNTING BRACKET
(Stainless Steel - included)

NOTES:

1. Shield from direct sunlight (Temp. probe in sensor).
2. Run sensor cable in grounded metal conduit with no other conductors.
3. Extend sensor cable with RG62AU coaxial only. Splice with terminal strip connections in recommended Junction Box.
4. Refer to the instruction manual for complete installation and wiring information.