

Kaye LabWatch® LT

User's Manual



imagination at work

M4580 Rev. C
April 2013

GE
Measurement & Control

Kaye LabWatch® LT

Monitoring System

User's Manual

M4580 Rev. C
April 2013



<http://www.ge-mcs.com/en/validation-and-environmental-monitoring.html>

©2013 General Electric Company. All rights reserved.
Technical content subject to change without notice.

Chapter 1. The GE Kaye LabWatch LT Monitoring System**Chapter 2. Installing Kaye LabWatch LT**

2.1 System Requirements	3
2.1.1 Peripherals	4
2.1.2 Computer Software	4
2.1.3 Application Software	4
2.2 Setting up RF ValProbe Hardware	5
2.2.1 Setting Up the Base Station	5
2.2.1aConfiguring a New Base Station	7
2.2.2 Connecting an External Sensor and Auxiliary Inputs	13
2.2.3 Setting up the Loggers	14
2.2.4 Logger Installation Guidelines	16
2.3 Installing Kaye LabWatch LT Software	17
2.3.1 User Registration	19
2.3.2 Discovering Base Stations and Loggers	20
2.3.3 Associate Sensors with Tags	23
2.3.4 Configure Tags	26
2.3.5 Create Tag Groups	31
2.3.6 Associating Users with Tag Groups	33
2.3.7 Defining and Modifying User Schedules	34
2.3.8 Defining and Modifying User Schedules (cont.)	35
2.3.9 Defining Alarm Notifications	36

Chapter 3. Monitoring Sensors with Kaye LabWatch LT

3.1 The Monitoring Screen	40
3.2 Views on the Monitoring Screen	44
3.2.1 The List View	44
3.2.2 The Graph View	46
3.2.3 The Floor View	47
3.3 Viewing Tag Data in Detail — The Tag Maintenance Screen	49
3.3.1 The Trending Tab	49
3.3.2 Tabular Data for a Tag	50
3.3.3 The Alarm Configuration Tab	51

Chapter 4. Graphing Tag Data

4.1 Configuring the Graph — the Chart Configuration Screen 55

 4.1.1 Entering Content 55

 4.1.2 Determining the Graph Appearance — Chart Configuration 56

 4.1.3 The Y Axis Tab 57

 4.1.4 Marker Properties 58

 4.1.5 Limit Lines 59

 4.1.6 Graph Template 60

 4.1.7 Plotting a Graph for Multiple Y-Axis 60

4.2 Basic Chart Controls 61

Chapter 5. Monitoring Active Alarms

5.1 Acknowledging Alarms 67

5.2 Viewing the Alarm History 69

Chapter 6. Viewing the Audit Trail

Chapter 7. Creating Reports

7.1 Report Types 76

7.2 Reporting Operation and Benefits 77

7.3 Creating a Daily Report 78

7.4 Creating a Historical Report 79

7.5 Creating a MKT Report 81

7.6 Creating an Alarm Report for a Single Tag 82

7.7 Creating an Audit Trail Report 83

7.8 Creating a Calibration Report 84

7.9 The Report Viewer Toolbar 85

7.10 Deleting a Report Template 86

Chapter 8. Configuring Kaye LabWatch LT

Appendix A. Configuring Telephone Notifications

A.1 Prerequisites 101

A.2 Installing Diva Analog 2p Board 102

 A.2.1 Inserting Your Diva Media Board into Your Computer 102

 A.2.2 Connecting Your Dialogic® Diva® Analog Media Board 104

A.2.2aDialogic® Diva® Analog-2 Media Boards	104
A.3 Configuring the Diva Board	106
A.4 Testing Diva Board	107
A.5 Configuring Telephone Settings.	110
A.6 Configuring a User Account for Receiving Alarms.	112
A.7 Telephone Alarm Notification Process	115
A.7.1 Steps in a Call.	115
A.7.2 The Telephone Notification Process.	115
Appendix B. Configuring Email Notifications	
B.1 Requirements	117
B.2 Configuring Email Settings	118
B.3 Configuring the User Account for Receiving Alarms	120
Appendix C. Battery Count Reset	
C.1 Logger Battery Change and Battery Count Reset	123
Appendix D. Glossary	

Chapter 1. The GE Kaye LabWatch LT Monitoring System

The GE Kaye LabWatch LT monitoring software system integrates RF ValProbe sensors, measurement hardware and networked PCs into a comprehensive solution for laboratory, warehouse and stability monitoring. Customers can incorporate wireless sensors for differential pressure, relative humidity, temperature, contact closure, CO₂, and any wireless device that outputs an analog or digital signal. They can also add, replace or delete sensors as a facility expands or changes.

LabWatch LT software combines three functions. The system monitoring software allows users to perform real-time monitoring of groups of sensors, with color coding to indicate alarm levels. Users can click on individual sensors for more detailed information on trending, tabular data and alarm configuration, or to change the sensor tag description. The Alarms screen provides lists of recent alarms, and the Audit screen allows users to record and check the audit trail. For system administration, the Configuration screen enables system administrators to manage alarm contacts (e-mail and telephone) and acknowledgements, user accounts, calibration records, tag and group configurations, and basic system display parameters. All comments are held in a secure database that becomes part of the permanent record, archived to a secure audit trail in compliance with 21 CFR Part 11.

To signal personnel immediately when alarm events occur, LabWatch LT provides alarm notification via telephone and e-mail contacts:

- A flashing area on main screen shows the alarm location and details the alarm condition
- Automatic dialing/emailing from a priority list that calls personnel via telephone or e-mail
- User dial-in from a remote site to inquire about system status.

Automatic dialing for remote personnel allows LabWatch LT to deliver a message using text to speech messaging to notify the recipient of the alarm description and condition. An administrator can arrange the calling list in a cascading fashion to ensure the most efficient response to alarm situations.

Report creation allows you to create reports from a secure database. Users can generate six types of reports: Real-time, History, Single Tag Alarm, Mean Kinetic Temperature (MKT), Audit Trail and Calibration reports. A query function provides access to any type of Audit Trail reporting, from complete reports over any time period to specific reports focused on a particular system point or event.

To control user access, a system administrator grants access privileges and maintains the operator list. Each user receives an individual user ID and password combination that allows entry at the appropriate security level.

Chapter 2. Installing Kaye LabWatch LT

Installing and setting up LabWatch LT is fairly straightforward. However, you must first be sure that your PC meets the necessary requirements.

2.1 System Requirements

- OS compatibility (MS Windows 7 32 bit and 64 bit, MS Windows XP SP3 32 bit, MS Windows Server 2008R2-Standard). English, German, French, Italian, Spanish, Portuguese and Chinese language version of above mentioned operating systems are supported.
- Minimum P4 or equivalent PC/Server design capable of running the required MS Operating System (OS).
- Memory – Minimum 4 GB of RAM
- Hard Drive – Minimum 40 GB free space
- CD or DVD Writable Drive
- Internet access
- IP address (assigned by customer’s IT department) for each Base Station used
- One direct-connect USB (hubs or expansion cards do not work)
- One PCIe (1x or greater) slot for telephony media board
- 101-key standard Keyboard and mouse (can be used with KVM switching)
- Graphics – 1024x768, 256 color resolution
- SVGA flat screen or LCD monitor (17-inch recommended, can be used with KVM switching)
- 10/100/1000 Network Interface

2.1.1 Peripherals

- Networked black and white or color laser printer for all reports and printouts. (Optional, recommended)
- Local color ink jet/laser printer for all reports and printouts. (Optional)

2.1.2 Computer Software

- OS compatibility (MS Windows 7 32 bit and 64 bit, MS Windows XP SP3 32 bit, MS Windows Server 2008R2-Standard)
English, German, French, Italian, Spanish, Portuguese and Chinese language versions of above mentioned operating systems are supported.
Hot Fixes is optional but strongly recommended.

Note: *LabWatch LT software package will be installed based on language OS (Windows 7 German, Windows 7 English, etc.) instead of regional and language option selection in operating system. For any language OS which is not supported, the English version will be installed by default.*

- Anti-Virus and anti-Spyware/Spam software (Optional, highly recommended)
- Word processing, spreadsheet software and Adobe Reader (Optional; export of reports to Word, Excel and PDF format not possible in absence of MS Office, no other impact on the system)

2.1.3 Application Software

- LabWatch LT 1.0 software package

IMPORTANT: *RF ValProbe, LabWatch Pro and LabWatch LT cannot run on the same machine. GE recommends using the LabWatch LT machine only for LabWatch LT.
GE cannot test with all applications that could possibly be installed and cannot guarantee how the system will react with other software on the same machine.*

2.2 Setting up RF ValProbe Hardware

Before you install LabWatch LT, be sure your RF ValProbe Base Station (s) and Loggers are transmitting and receiving in a network linked to the PC in which you have installed LabWatch LT.

Setting up an RF ValProbe hardware system for operation involves three steps.:

1. Setting up the Base Station.
2. Connecting any External Sensors or Auxiliary Inputs.
3. Setting up and positioning the Loggers.

2.2.1 Setting Up the Base Station

Starting the Base Station requires plugging in the power supply and the USB or Ethernet connections. The rear of the Base Station appears similar to Figure 1 below.



Figure 1: Base Station Connections

- To power the Base Station, insert the round barrel connector into the power input jack of the Base Station (the input at the left shown in Figure 1 on the previous page). Attach the power supply to the power cord. Then insert the power cord into a standard 100-240 VAC outlet. A green light next to the power outlet on the Base Station indicates that the station is powered up.
- For USB use, a separate USB-adaptor-cable plugs into a USB socket on the user's PC. The other end of the USB-adaptor-cable fits into the 10bT Ethernet socket on the Base Station. Use only ONE USB-adaptor-cable on a PC.

IMPORTANT: *The external power supply included with your RF ValProbe is fitted with an AC power cord suitable for the country of destination.*

2.2.1 Setting Up the Base Station (cont.)

A new Base Station needs configuring before it is added to the LabWatch LT system. By default, Base Stations are in USB mode but must be switched to Ethernet. Configuration involves four steps:

1. Switch the Base Station from USB to Ethernet mode.
2. Put the Base Station on the Ethernet and make sure it is online and that the LabWatch LT PC is able to ping it.
3. Assign an RF network ID to Base Station, All Loggers intended for the Base Station should also be set with same Network ID manually; all loggers will communicate with the Base Station on that Network ID. However, be sure no two Base Stations have same network ID.
4. Perform the Base Station's Time Synchronization against the PC Time on which Lab watch Lite Software is running.

Note: *While performing this step, make sure the "Windows Time" service is running on the PC.*

Be sure you have installed LabWatch LT and entered users (see page 17). To begin configuration, proceed to the second tab (page 20) and click on **Configure New Base Station**.

2.2.1a Configuring a New Base Station

Setting up a New Base Station for the Configuration on PC

- a. Use CTA5 Crossover cable to connect the USB-Adapter and Base Station. Put one end of the crossover cable into the Base Station's Ethernet port and the other end into the USB-Adapter's Ethernet port.
- b. Plug-in the USB-Adapter into the PC's USB Port.
- c. The USB Adapter will be detected and Network properties will show a new connection as shown in Figure 2 below.

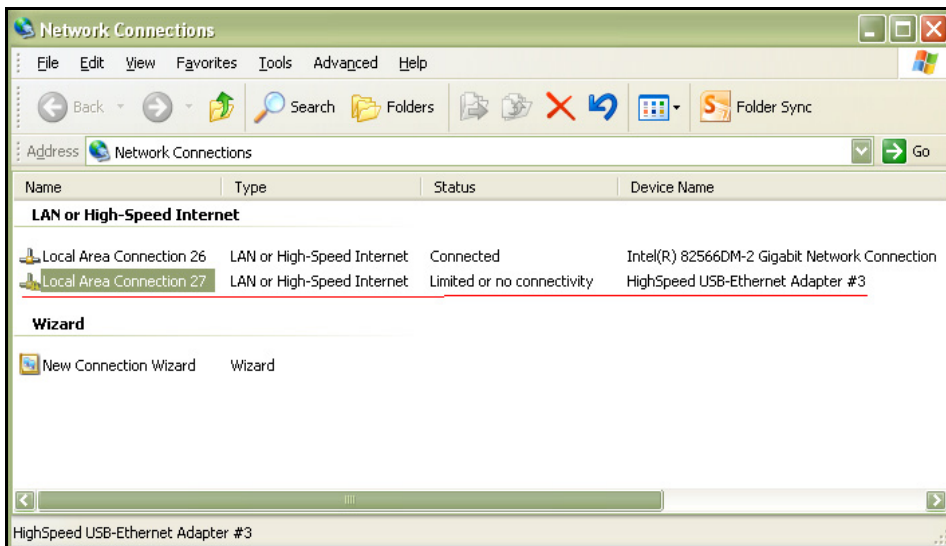

Figure 2: Network Properties with New Base Station

A new Base Station needs configuring before it is added to the LabWatch LT system. By default, Base Stations are in USB mode but must be switched to Ethernet. Configuration involves the following steps on Ethernet and USB:

Note: Please skip Step 1, 2 and 6 for configuring Base Station on USB.

2.2.1a Configuring a New Base Station (cont.)

1. Switch the Base Station from USB to Ethernet mode.
2. Put the Base Station on the Ethernet and make sure it is online and that the LabWatch LT PC is able to ping it.
3. Assign an RF network ID to Base Station. All Loggers intended for the Base Station should also be set with same Network ID manually; all loggers will communicate with the Base Station on that Network ID. However, be sure no two Base Stations have the same network ID.
4. Perform the Base Station's Time Synchronization against the PC Time on which Lab watch Lite Software is running.

Note: *While performing this step, make sure the "Windows Time" service is running on the PC.*

1. Use the link **Click Here to find Base Station on USB** to detect the Base Station on the USB-Ethernet Adapter.

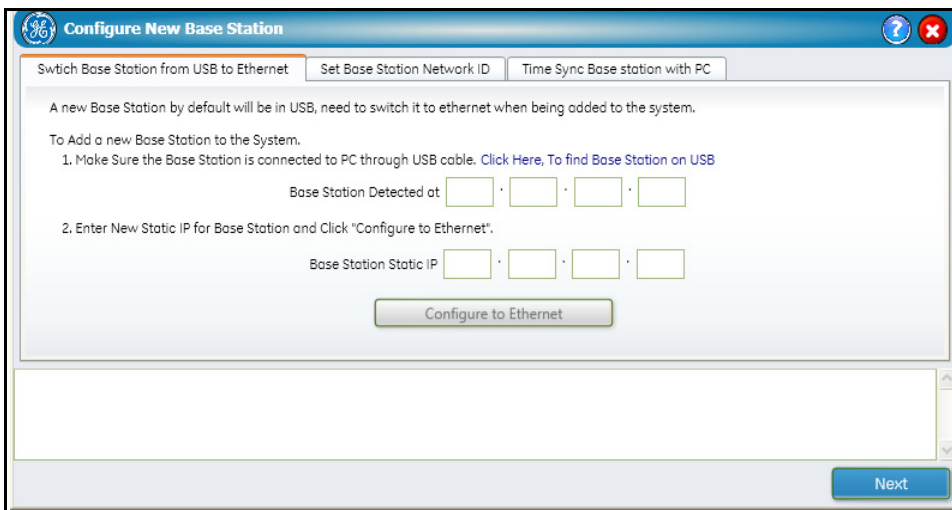

Figure 3: Switch Base Station Tab

2.2.1a Configuring a New Base Station (cont.)

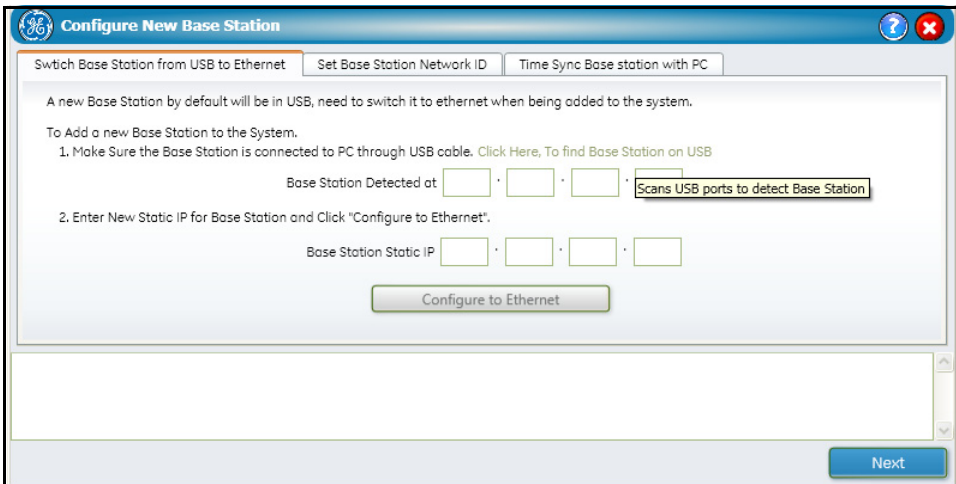

Figure 4: Scanning USB Ports

If a Base Station is connected through the USB port, then the Base Station IP address will appear in the “Detected at” text box after “**Click Here to find Base Station on USB**” is clicked.

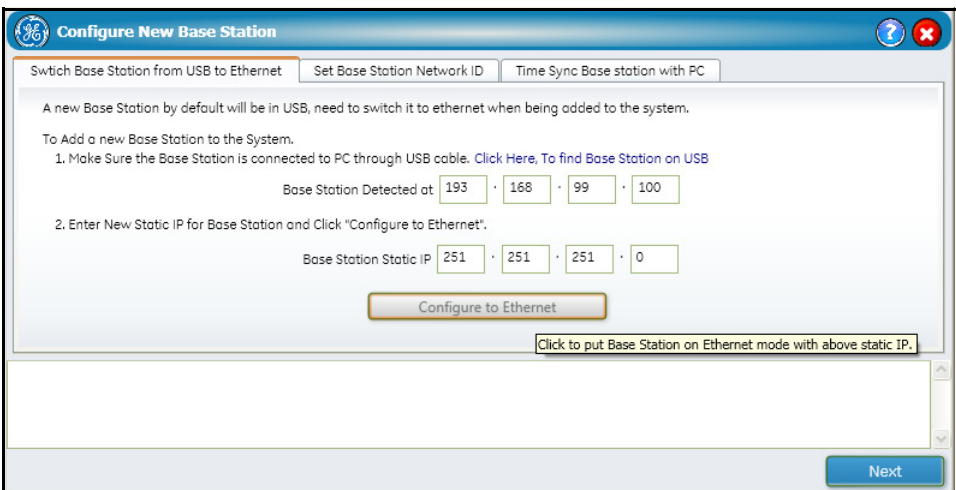

Figure 5: Detected Base Station

2.2.1a Configuring a New Base Station (cont.)

2. Enter the new “Base Station Static IP” which has to be assigned to the Base Station. Your business IT department may need to assign this unique Static/Fixed-address/Reservation IP address using their network configuration tools. Click **Configure to Ethernet**. Once successful, the “IP Address Switched Successfully” message will appear.

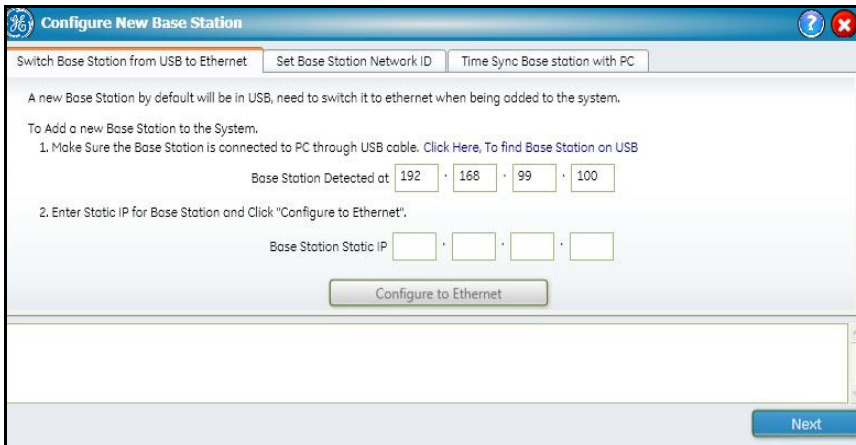

Figure 6: Configure to Internet

3. Click **Next** to configure the Base Station’s RF Network ID.

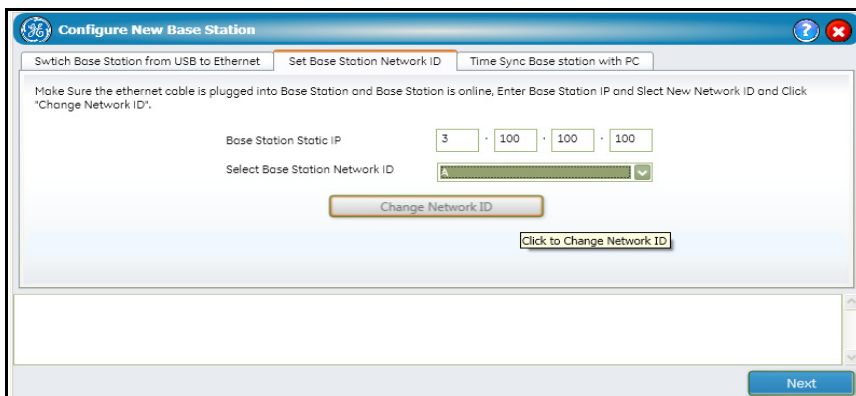

Figure 7: Network ID Configuration

2.2.1a Configuring a New Base Station (cont.)

4. Enter the Base Station's Static IP. Enter the new RF Network ID, and click **Change Network ID**. Current Network ID of the Base station is detected and a confirmation message is prompted. For easy identification and future use, please affix a tag to the Base Station noting the selected Base Station IP address and the RF Network ID.

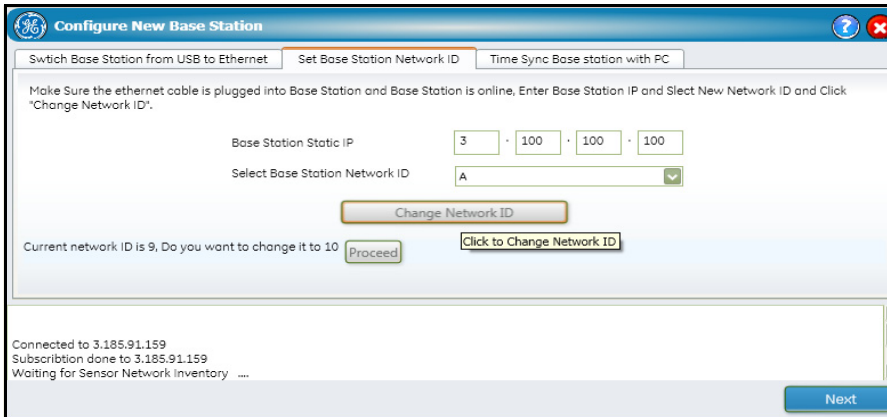

Figure 8: Confirmation Message

5. Click **Proceed** to confirm you want to change the ID. Once done, the “Network ID Changed Successfully” message appears.
6. Click **Next** to proceed to Time Synchronization of the Base Station with the LabWatch LT PC.

2.2.1a Configuring a New Base Station (cont.)

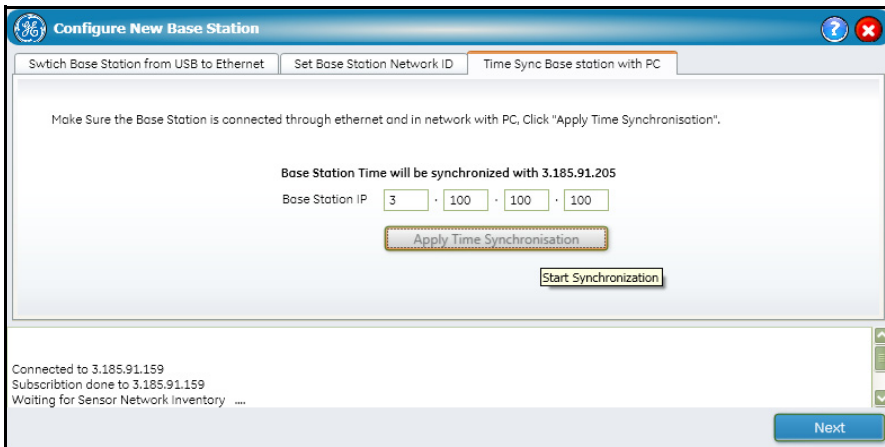

Figure 9: Time Synchronization

Now you must synchronize the Base Station’s time with that of the PC on which LabWatch LT is running. The IP address of the PC is displayed; a user needs to enter the Base Station IP address.

Make sure the “Windows Time” is running on the PC and then click **Apply Time Synchronization**. Once done, the message “Base Station Time Synchronization is Successful” appears.

Loggers on the Base Station also need their times synchronized with that of the Base Station; do this manually by power resetting all the loggers. Please follow the steps below to sync the logger time with Base Station Time:

1. Power OFF the logger, and change the Base Station ID, to anything other than the original ID.
2. Power ON the Logger.
3. Power OFF the logger, and change the Base Station ID back to the original.
4. Power ON the Logger.

Once you have added the Base Station to the network and synchronized the time, continue with setting up the LabWatch LT system as shown on page 20.

2.2.2 Connecting an External Sensor and Auxiliary Inputs

If any of your Loggers are designed for use with an external sensor, that sensor will have been shipped in the same package as your Logger.

- To connect the sensor to the Logger, simply slide the connection end of the sensor into the hole on the right side of the Logger.
- To disconnect the sensor from the Logger, pull back the connection sleeve (the grooved part visible outside the connection) and you can pull out the sensor.

CAUTION! When handling external sensors, avoid bending the sensor near either the tip or connector ends. Repeated bending will damage the sensor.

You connect auxiliary inputs (4-20 mA, 0-10V or contact closure) via the terminal at the top of the Logger shown in Figure 10 below. Figure 11 below illustrates wiring connections for the auxiliary inputs.



Figure 10: Auxiliary Input Terminal

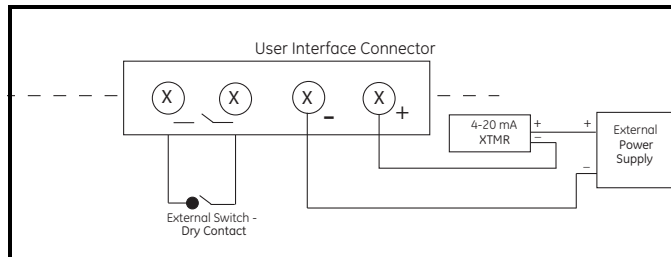

Figure 11: Interface Connector Wiring Diagram

2.2.2 Connecting an External Sensor and Auxiliary Inputs (cont.)

Note: For a 2 or 5-channel Logger, the sensors are prewired to terminal blocks inside the Logger. To replace or reattach a sensor, you must remove the cover and retaining bar, remove the terminal block for the existing sensor, attach the terminal block of the new sensor, and replace the retaining bar and cover.

2.2.3 Setting up the Loggers

When you are setting up the Loggers, you must first be sure that they are switched on, and that they have the same network ID (from 0 to 9 or A to F) as the Base Station. (For instance, all Loggers must have the network ID “5” if the Base Station has the ID “5”.)

IMPORTANT: If you have more than one Base Station, each one must be configured with a unique network ID.

To switch on the Logger, see the back of the Logger above the battery panel, as shown in Figure 12. Slide the switch below the network ID wheel to the right to turn on the logger.

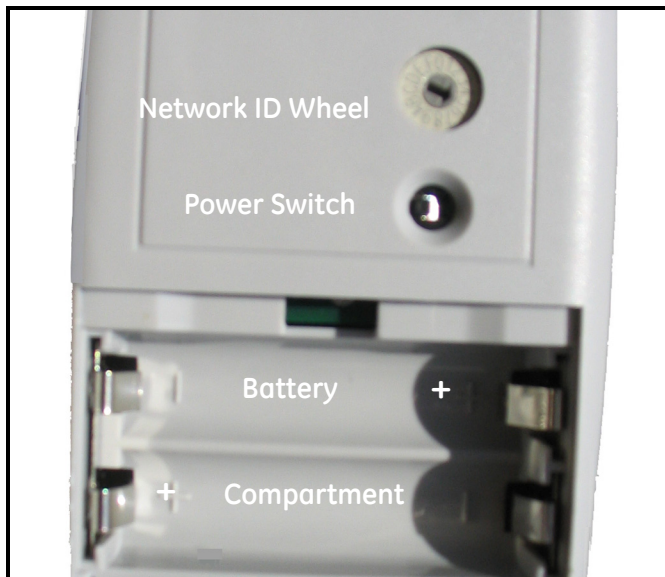

Figure 12: Logger Battery Compartment, Power Switch and Network ID Wheel

2.2.3 Setting Up the Loggers (cont.)

Be sure the network ID for both Base Station and Loggers is set up as shown on page 15.

If you need to adjust the Logger's network ID, use a small screwdriver to turn the arrow in the middle of the network ID wheel in Figure 12 on page 14. Be sure the arrow points to the appropriate ID number. (You can choose from numbers 0 through 9, and letters A through F.)

Note: *You must change the Logger network ID before you switch on the Logger. If you have already switched the Logger on, switch it off and then turn it back on so the Logger can read the correct ID.*

2.2.4 Logger Installation Guidelines

You can now position the Loggers. Each Logger must be no more than 300 ft. distant from the Base Station and the other Loggers. GE offers several recommendations for logger placement:

- Install the Loggers at least one to two feet above the ground or floor. For better RF transmission, place them as high as possible. If possible, raise or lower the Base Station and Loggers above or below walls or any obstruction.
- Point the Logger antenna upwards for best results.
- Do not position the Loggers directly above or below each other. Stagger their positions for better transmission.
- If Loggers are placed at different heights, make sure that they are within antenna range (within 300 ft. from the Base Station or another logger). The RF signal is transmitted in an arc, with maximum signal strength occurring in the area 45° above and below the tip of the antenna.
- Be aware that metal surroundings can interfere with RF transmission; the Logger may transmit, but the signal will be weaker. Shorten the transmission distance accordingly.
- Do not install Loggers next to a cordless phone base or other 2.4 GHz transmission device.
- Do not install Loggers on a vibrating surface.
- Do not place Loggers where the temperature is outside their rated operating range.

IMPORTANT: *If you are using Loggers with internal sensors, be sure the vents on the side remain uncovered. If the vents are covered, the sensors cannot provide correct readings.*

2.3 Installing Kaye LabWatch LT Software

To begin installation, insert the LabWatch LT CD into the CD drive. Follow the steps in the *LabWatch LT Startup Guide* to install the software.

Once you have installed LabWatch LT, click on **Start >Programs>LabWatch LT** to open the program. The Login window opens.



The image shows a login dialog box for Kaye LabWatch LT. The dialog box has a blue title bar with the GE logo on the left and the word "LOGIN" in white text on the right. Below the title bar, there are three input fields: "USER ID" (a single-line text box), "PASSWORD" (a single-line text box), and "COMMENT" (a multi-line text area with vertical scrollbars). At the bottom of the dialog box, there are two buttons: a yellow "OK" button and a blue "CANCEL" button.

Figure 13: Login Window

2.3 Installing Kaye LabWatch LT (cont.)

The Configuration Wizard will open before you launch LabWatch LT if the following conditions are met:

1. No users have been created
2. No tags have been defined

Through the Configuration Wizard you can create user accounts, discover Base Stations/Loggers, associate a sensor with a tag, set tag properties, create tag groups, associate users with tag groups, and associate schedules with users.

The following sections describe configuration steps.

2.3.1 User Registration

In a newly installed system, no user accounts exist for LabWatch LT. So when you start LabWatch LT for the first time, a Registration window appears in which you can create new users. For each user, enter the relevant data in the fields.

Figure 14: User Creation Screen

Users can be one of three types, each with specific permissions:

System Administrator - Creates and maintains user accounts, locks and unlocks the system, sets site options and system preferences, backs up and restores user information, and views, prints, and maintains the audit trail. The System Administrator also performs Logger calibration.

Operator - Can view screens and create reports, Operators can also have particular permissions if the System Administrator has set them up with specific permissions in this window.

Guest - Can view screens, but cannot change any parameters.

IMPORTANT: *Whenever new users are created, they are assigned default passwords that are the same as their User IDs. A user must change the default password at first log in.*

After creating the required number of user accounts, click **Next** to configure the base station and loggers, as explained on the following pages.

2.3.2 Discovering Base Stations and Loggers

In the next window, click on **Discover Base Stations** to determine what Base Stations are on your network, and click on **Get Loggers** to find the Loggers for each of the selected Base Stations. You can also **Enter an IP Address** to locate a particular Base Station.

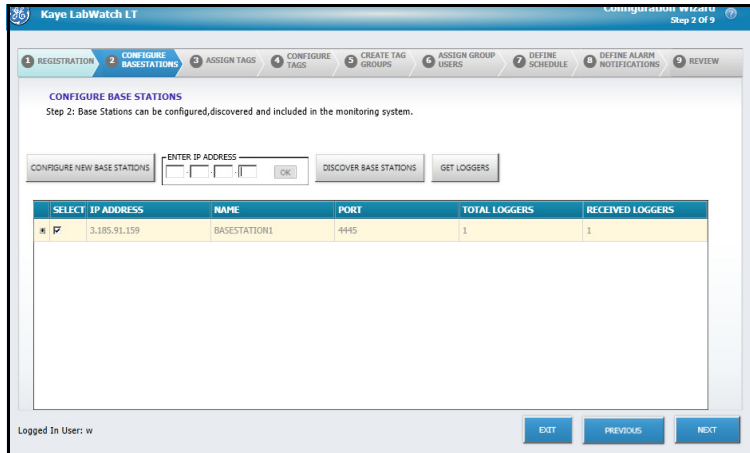

Figure 15: Configure Base Station Window

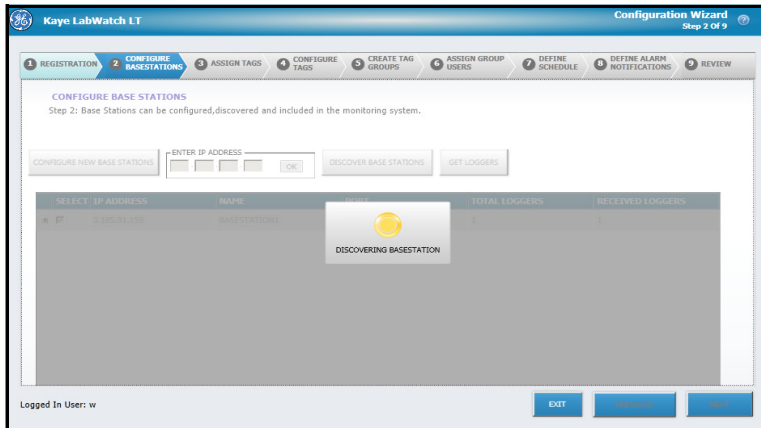

Figure 16: Discovering Base Stations

2.3.2 Discovering Base Stations and Loggers (cont.)

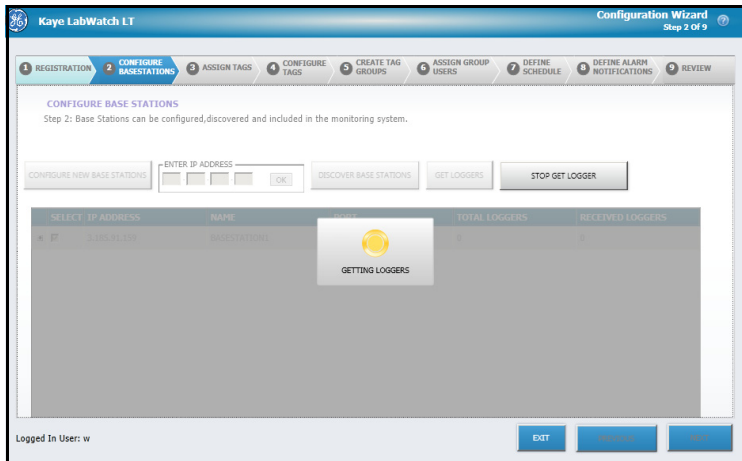

Figure 17: Getting Loggers

When a user clicks on **GET LOGGERS**, it toggles to a **STOP GET LOGGERS** button. Clicking on **STOP GET LOGGERS** will stop LabWatch LT from searching for Loggers from selected Base Stations.

After the Loggers have been received and displayed, a user can select/unselect Base Stations and Loggers by clicking the corresponding check boxes. Click **Next** when you have finished.

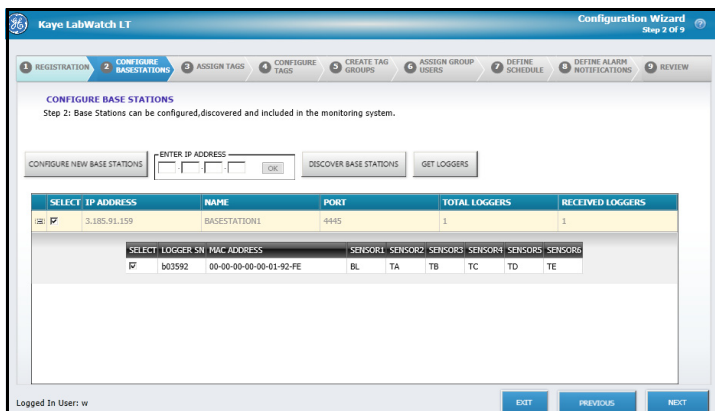

Figure 18: Screen Populated with Base Stations

2.3.2 Discovering Base Stations and Loggers (cont.)

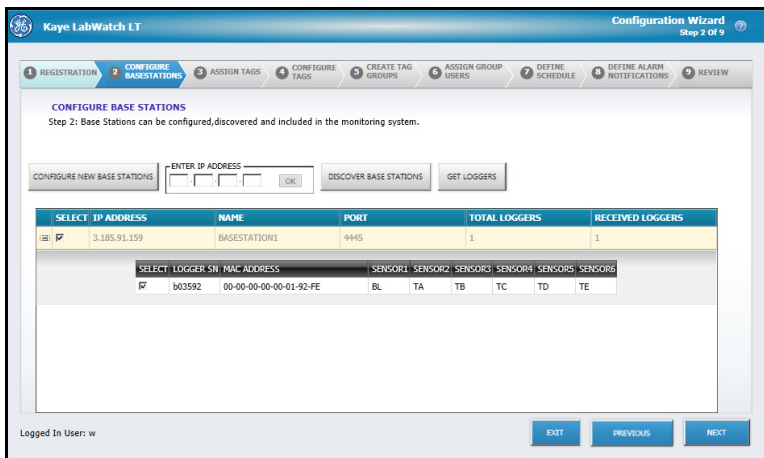

Figure 19: Populated Screen with Selected Loggers

Note 1: You can configure four (4) Base Stations. Two Base Stations can have 40 loggers per Base Station; overall, you can configure no more than 100 loggers. Note that you can have only one (1) Base Station configured for USB.

Note 2: If you want one of the Base Stations configured for USB, then it should be added manually using Enter an IP Address (IP 192.168.99.100), only after you have configured and added other Base Stations on Ethernet.

2.3.3 Associate Sensors with Tags

IMPORTANT: *Tags cannot be generated without license info, so to generate the license key, click on the **License Key** button and enter a valid license key as shown below. Once a valid key is entered, tags can be generated, otherwise a message will pop up if it exceeds the limit. Even if the number of tags exceeds the limit, a user can still generate the tags but can only generate up to the license key provided.*

Once the license key is entered, clicking on the **Evaluate** key will connect to the product key evaluation server to generate the license information. On receiving the license info, the license to number of tags will be listed and a user can proceed further for tag generation; otherwise appropriate messages will be displayed on unsuccessful product key entry.

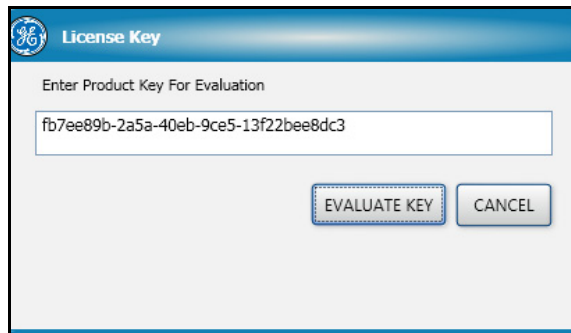

Figure 20: License Key Evaluation

When you have populated the list, click on the **Next** button to proceed to the Assign Tags tab (Figure 21 on the next page). In the Enabled column, clear the checkbox for any tag you do not want to enable. In the Tag and Tag Description columns, you can enter your own tag IDs and descriptions. To create automatic tags, click the **Generate Tag** button. If you need to reassign a tag, click the **REASSIGN Tag** button. By default, “Group By” will list all the base stations. Selecting a particular base station will list sensors related to that selected base station.

2.3.3 Associate Sensors with Tags (cont.)

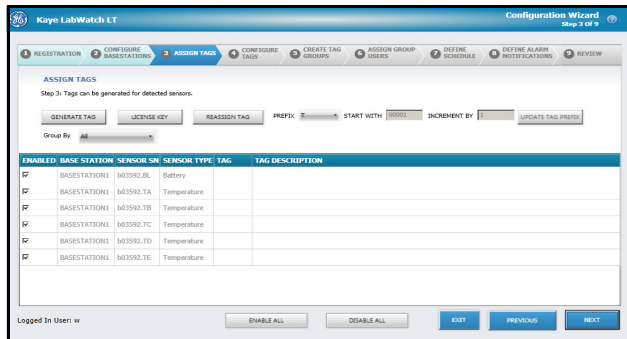

Figure 21: Assign Tags Tab

By default, tags are generated with prefix “T”, but you can change the tag prefix by selecting the required letter from the Prefix drop-down box. Then click on **Update Tag Prefix** to update the tag prefix for all tags. Remember that the option to change tag prefixes is a one-time activity, and that clicking **Next** will save tags into the database. Once a tag is saved into the database, the option to change tag prefix becomes invisible, so users will not be able to change the tag prefix anymore.

Clicking **ENABLE ALL** will enable all sensors.

Clicking **DISABLE ALL** will disable all sensors.

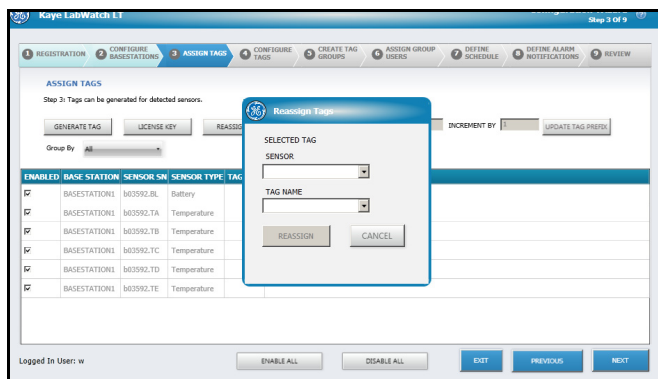

Figure 22: Reassigning Tags

2.3.3 Associate Sensors with Tags (cont.)

When you have completed sensor and tag association, click **Next** to configure tags.

2.3.4 Configure Tags

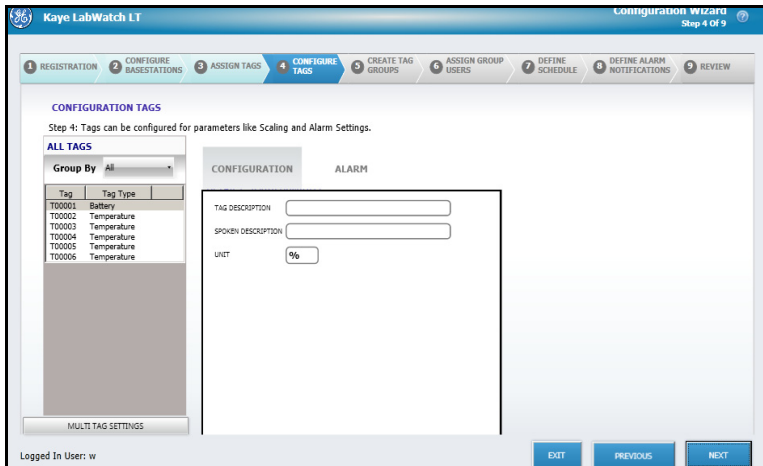

Figure 23: Configure Tags Tab

Click on any single tag, and the window for that tag opens at the **Configuration** tab. It includes text boxes for the **Tag Description**, **Spoken Description** (for telephone contacts) and **Measurement Unit** (C or F for temperature, % for relative humidity)

Click the **Alarm** tab, and you can enter alarm limits and delay times. Click the **Enable** box to apply the values you have entered for alarm limits.

2.3.4 Configure Tags (cont.)

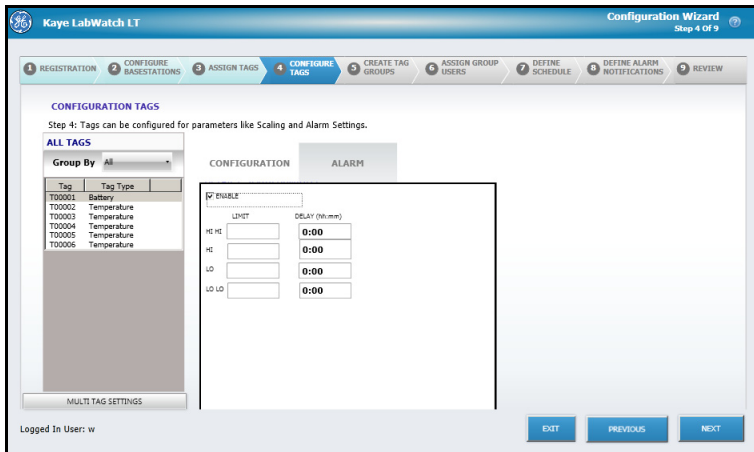

Figure 24: Alarm Tab

The tag window differs slightly for analog and digital auxiliary inputs. For analog inputs, a third tab, **Scaling**, appears.

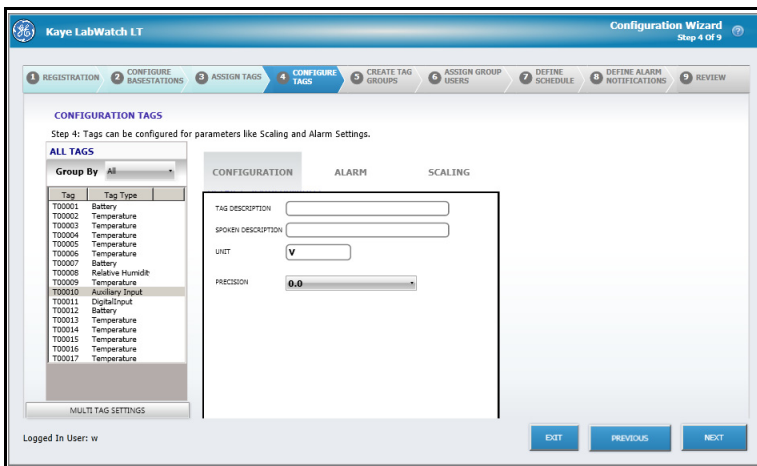

Figure 25: Configure Tags Tab (for Analog Inputs)

2.3.4 Configure Tags (cont.)

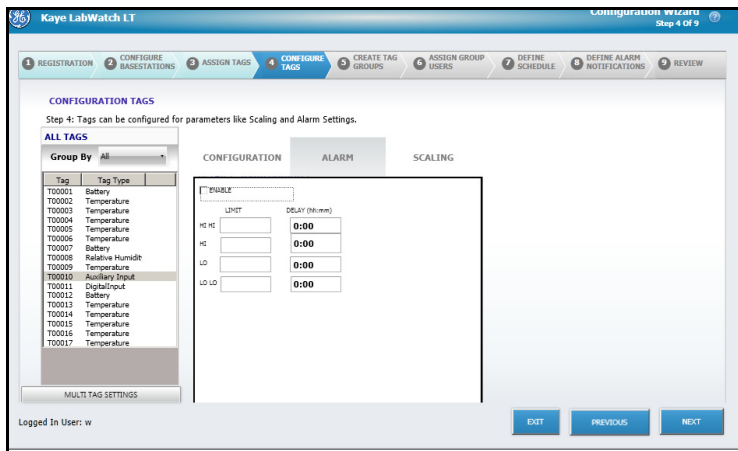

Figure 26: Configure Tags (Analog Inputs)—Alarm Tab

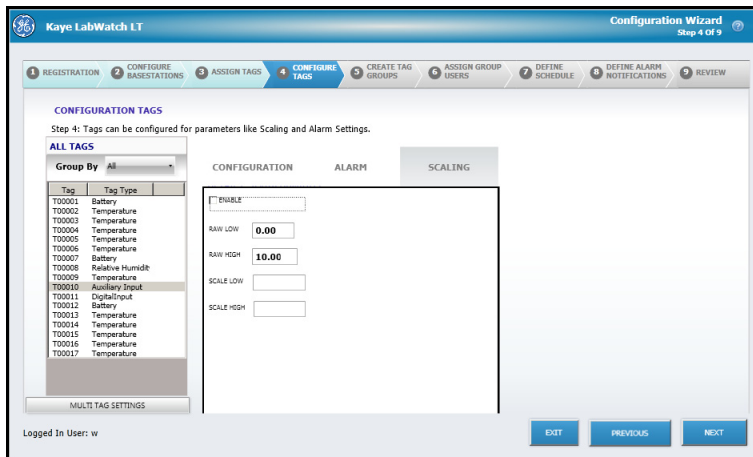

Figure 27: Configure Tags —Scaling Tab

On the Scaling tab, click **Enable** to enable scaling. Two windows display the current raw low and raw high values. Enter the **Scale Low** and **Scale High** values in the text boxes.

The tag window for a digital input has two tabs, but the inputs differ.

2.3.4 Configure Tags (cont.)

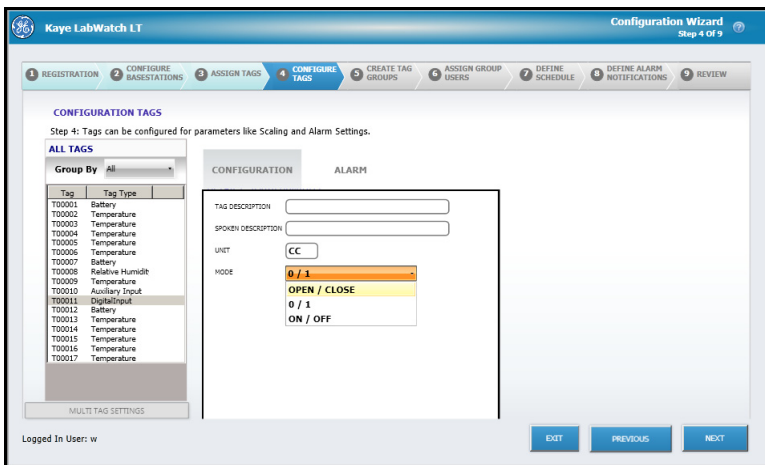

Figure 28: Configure Tags—Digital Inputs

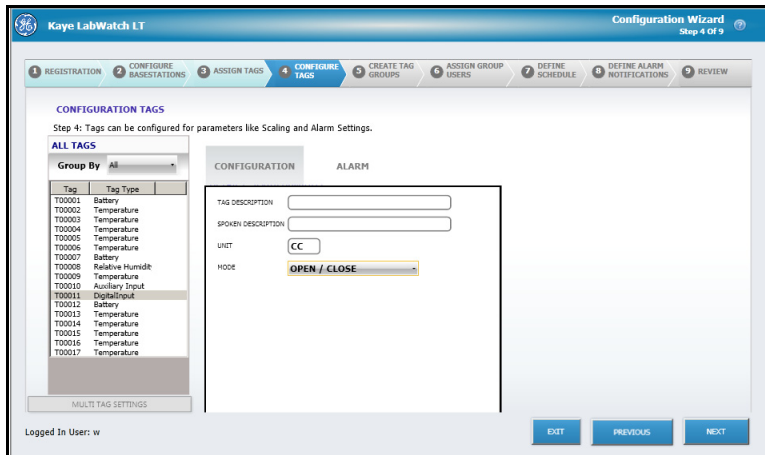

Figure 29: Mode Selection

On the Configuration tab, three modes are available in the drop-down list: **Open/Close**, **I/O** and **On/Off**. Click on the desired mode. On the Alarm tab, besides enabling alarms and setting a delay time, you can select an Alarm Mode of **Open** or **Close** from the drop-down list.

2.3.4 Configure Tags (cont.)

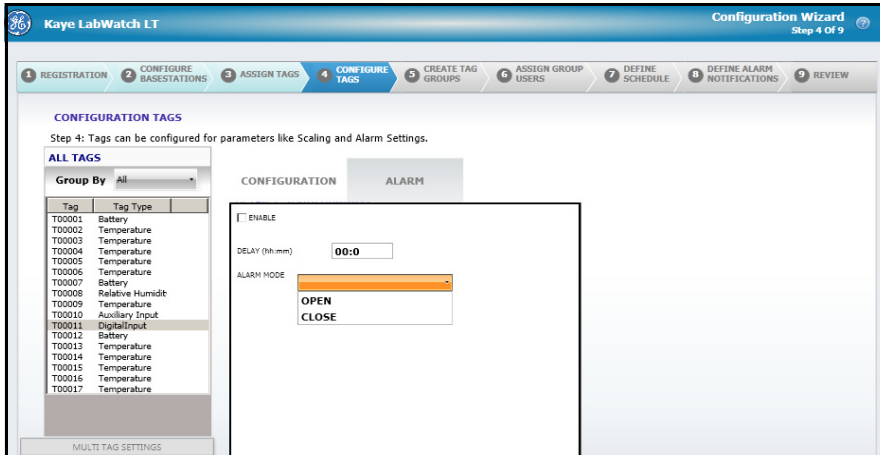

Figure 30: Alarm Mode Selection

If you select one/more tag (of type Temperature, Humidity, Auxiliary), the **Multi Tag Settings** button is enabled. Click this button, and you can apply common Lo, LoLo, Hi, and HiHi alarm limits and delays to the selected tags.

IMPORTANT: For *Multi Tag Settings* to work, a user should uncheck any DI tag within the list.

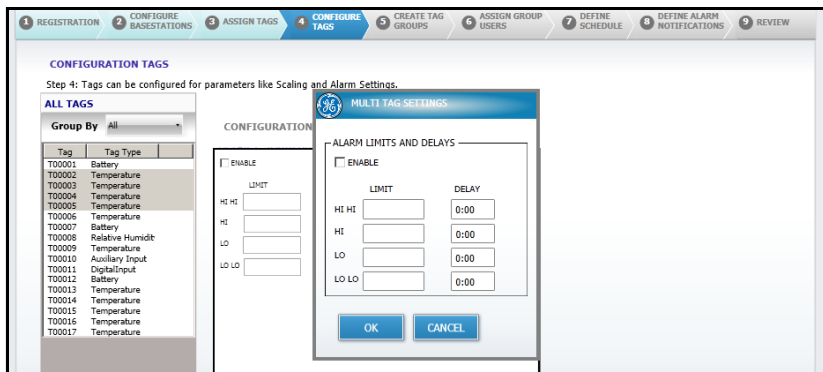

Figure 31: Multi Tag Settings Window

2.3.4 Configure Tags (cont.)

Click **Enable** to enable these limits, and then click **OK** to apply the limits and delays to the selected alarms.

2.3.5 Create Tag Groups

Clicking **Next** opens the **Create Tag Groups** tab in which a user can create/modify tag groups; by default, the battery group opens, as shown below.

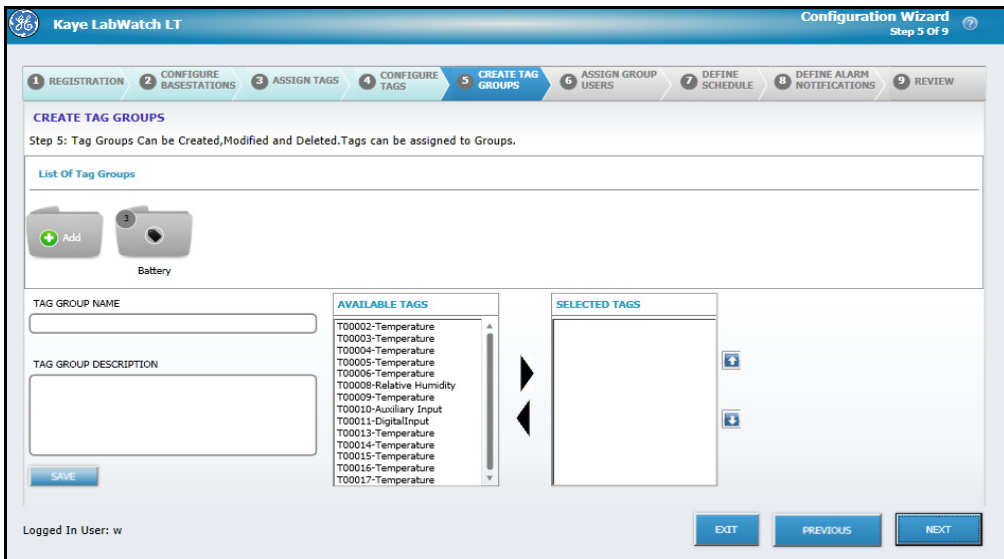

Figure 32: Create Tag Groups

The left pane of this tab lists the currently available groups. Click on the arrow button beside any group, and a list of associated sensors appears below the group name. (The same list appears in the “Selected” pane at the right.) When you select a group, the Available Tags list and Selected Tags list are updated to show the specific group. You can move tags between the Available and Selected lists.

To create a new group, click the **Add Group** folder icon in the upper list of tag groups. You can then create the group by entering the group name and description, and selecting tags. Then click **Save** to save group information. Clicking on the arrow (up/down) buttons allows you to set the order of tags.

2.3.5 Create Tag Groups (cont.)

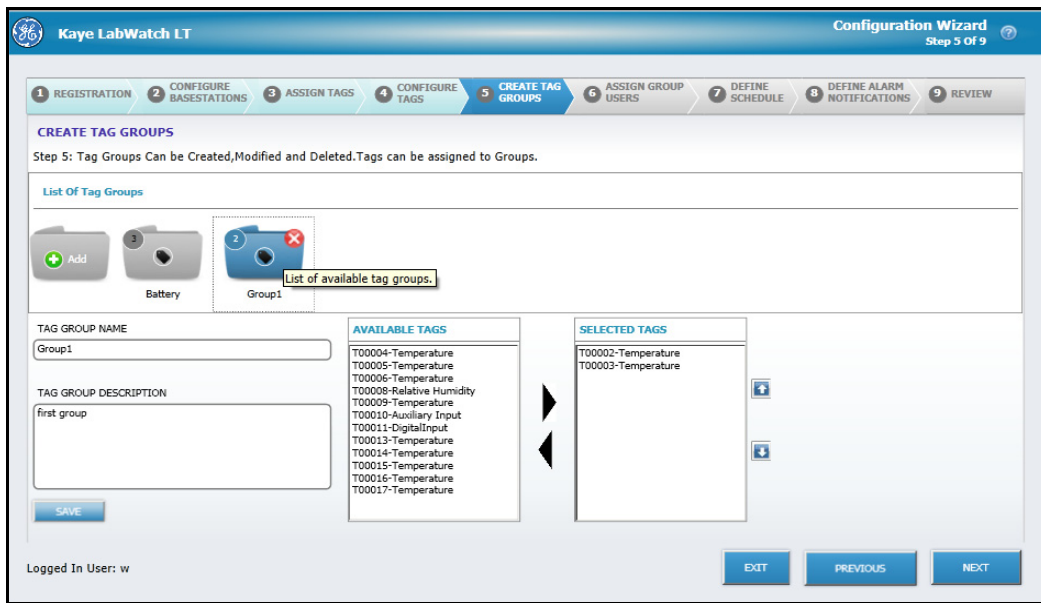

Figure 33: Adding a Group

To delete a group, select the group and click on the cross icon appearing on top right corner of the group folder icon.

Click **Next** to proceed to the **Assign Users** tab, where you can associate users with groups.

2.3.6 Associating Users with Tag Groups

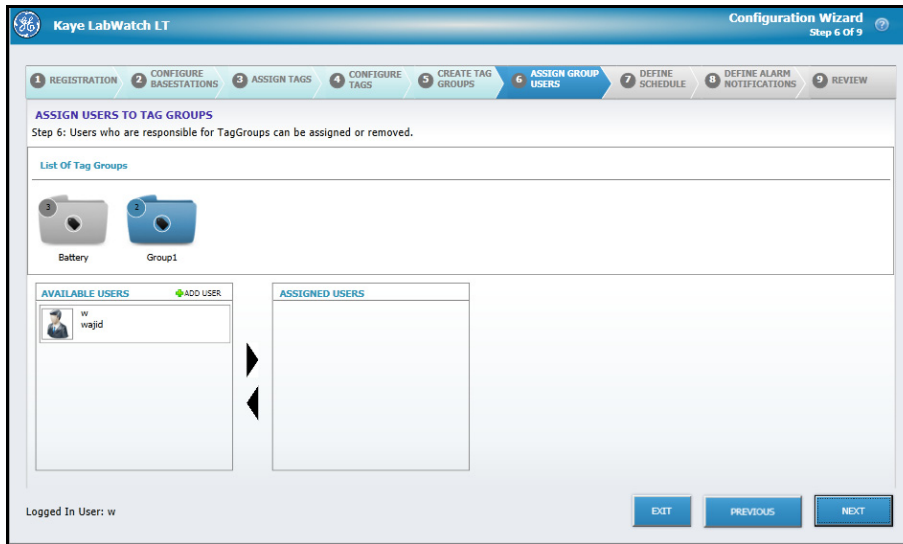

Figure 34: Assign Users Tab

Upon selecting a group, the Assigned User list is updated appropriately. You can also move users between the **Available** and **Assigned Users** lists. Clicking on the arrow (up/down) buttons allows you to set priority of users in a group.

To create a user, click on the **Add User** icon located on top right corner of the Available Users listbox. Clicking **Next** will display the **Define Schedule** tab, where you can associate schedules with a specific user of a group.

2.3.7 Defining and Modifying User Schedules

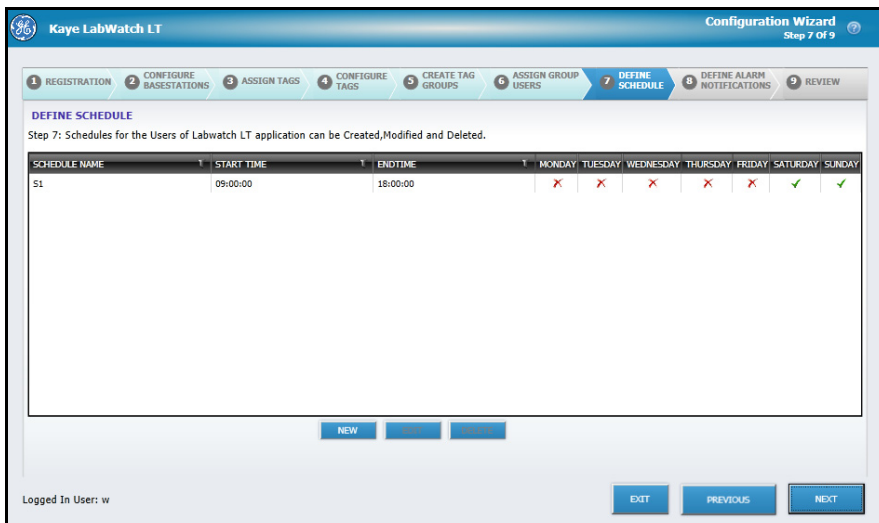

Figure 35: Define Schedules Tab

The Define Schedule tab displays all the available schedules. You can also create a new schedule or modify existing schedules here:

1. To create a schedule, click on the **NEW** button.

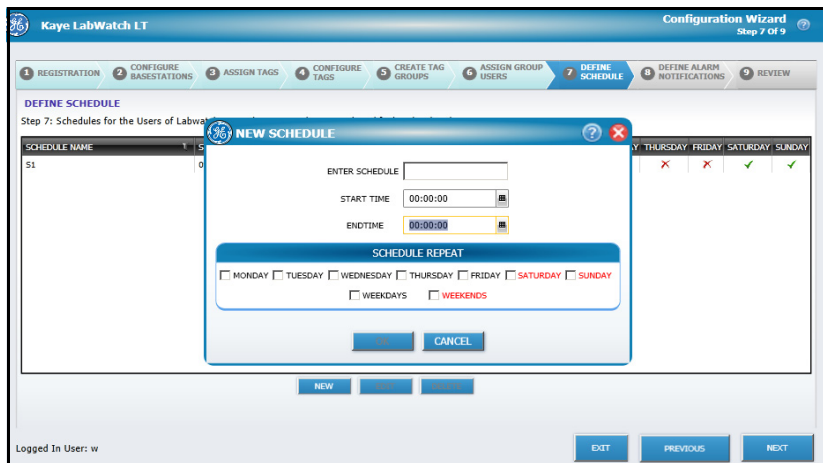

Figure 36: New Schedules Window

2.3.8 Defining and Modifying User Schedules (cont.)

- To edit a schedule, select the required schedule and click on the **EDIT** button.

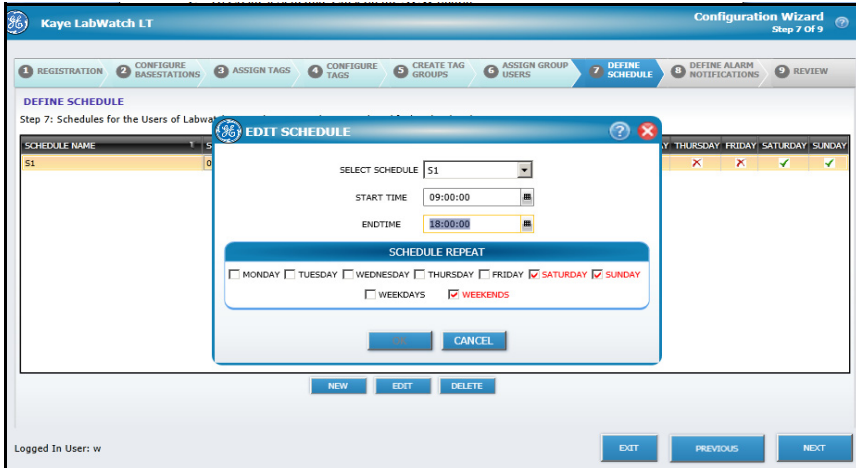

Figure 37: Edit Schedules Window

- To delete a schedule, select the required schedule and click on the **DELETE** button.

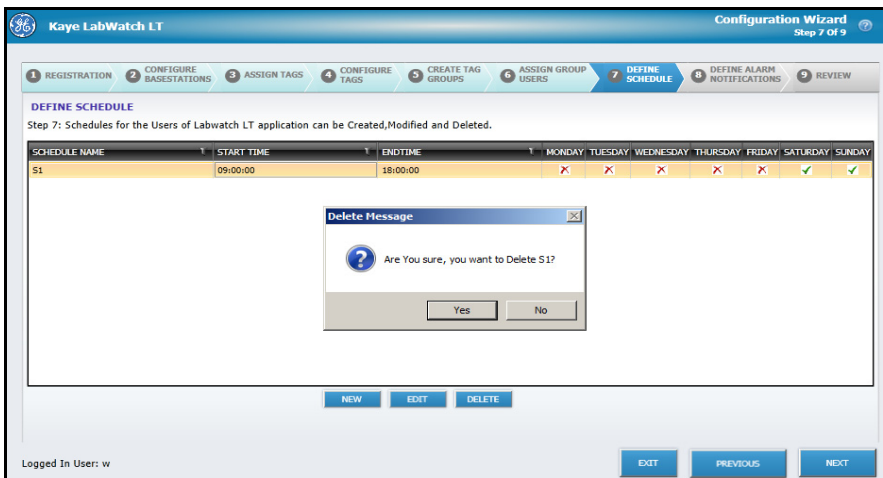

Figure 38: Delete Schedules Window

Clicking on the **Yes** button deletes the selected schedule.

2.3.9 Defining Alarm Notifications

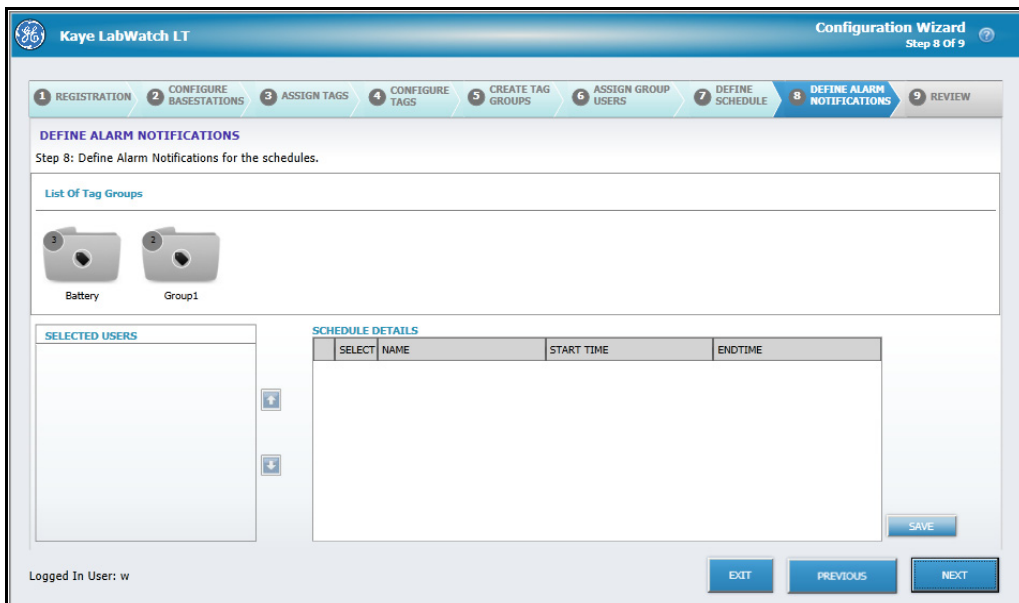

Figure 39: Defining Alarm Notifications

To associate a schedule with a user of a particular group:

1. Select a group.
2. Select a user from the selected users list.
3. Select a schedule. You can also create a new schedule by clicking on the Add icon located at the top left corner of the Schedule Details grid.
4. Select the notification type as needed.

You can also change the priority of users by clicking on the arrow (up/down) buttons. These up/down buttons allow you to set the priority of users in a group.

2.3.9 Defining and Modifying User Schedules (cont.)

Click **Next** to display the **Review** tab, where you can see a detailed report of activities performed in the last seven tabs.

Base Station

IP ADDRESS	NAME	PORT	TOTAL LOGGERS	RECEIVED LOGGERS
3.185.91.159	BASESTATION1	4445	1	1
3.185.91.28	BASESTATION2	4445	2	2

Assign Base Station

Enabled	Base Station	Sensor SN	Sensor Type	Tag	Tag Description
True	BASESTATION1	b03592.BL	Battery	T00001	
True	BASESTATION1	b03592.TA	Temperature	T00002	
True	BASESTATION1	b03592.TB	Temperature	T00003	
True	BASESTATION1	b03592.TC	Temperature	T00004	
True	BASESTATION1	b03592.TD	Temperature	T00005	
True	BASESTATION1	b03592.TE	Temperature	T00006	

Printed By w On 07/Nov/2012 12:00

Logged In User: w

Buttons: EXIT, PREVIOUS, FINISH

Figure 40: Review Tab

Click **Finish** to exit the Configuration Wizard and launch LabWatch LT.

[no content intended for this page - proceed to next page]

Chapter 3. Monitoring Sensors with Kaye LabWatch LT

Once you have installed and set up LabWatch LT, you can begin to monitor your sensors. If this is your first use of LabWatch LT, the Log In screen will ask you for your User ID and password. (For the first use *only*, enter the User ID in both columns.) The system will then ask you to enter and confirm a new password. Enter a new password with a minimum of six characters.

Once you have entered your new password, LabWatch LT opens at the System Monitoring screen. Click on a button for one of the groups you have created in Chapter 2, and the screen will appear similar to Figure 41 below.

The screenshot displays the Kaye LabWatch LT monitoring interface. At the top, the title bar shows 'Kaye Labwatch LT' and 'TOTAL ALARM COUNT: 7'. Below the title bar is a navigation menu with tabs for MONITOR, GRAPHING, ALARMS, AUDIT, REPORTS, CONFIGURATION, and COMMENTS. The MONITOR tab is active. On the right side, there are buttons for 'DISPLAY VIEW' and 'COLUMN LAYOUT'. Below these is a 'VIEW BY' dropdown menu set to 'List View'. The main content area shows a table titled 'Battery- Battery Group' with the following data:

SENSOR NAME	TAG NAME	STATUS	LOLO LIMIT	LO LIMIT	HI LIMIT	HIHI LIMIT	VALUE	IS ALARM ENABLE	DESCRIPTION
A1980.TA	T0001	LOLO	10.00	20.00	50.05	80.33	12 °C	<input checked="" type="checkbox"/>	Freezer 1
A1980.RH	T0002	LOLO	10.00	20.00	50.00	80.00	11 mA	<input checked="" type="checkbox"/>	Freezer 2
A1980.AUX	T0003	LOLO	10.00	20.00	50.00	80.00	11.30 V	<input checked="" type="checkbox"/>	Freezer 3
A1981.TA	T0006	HI	10.00	20.00	50.00	80.00	98 °C	<input checked="" type="checkbox"/>	Freezer 6
A1981.RH	T0007	HI	10.00	20.00	50.00	80.00	91 mA	<input checked="" type="checkbox"/>	Freezer 7
A1981.AUX	T0008	HI	10.00	20.00	50.00	80.00	97 V	<input checked="" type="checkbox"/>	Freezer 8

At the bottom of the interface, there are two folder icons labeled 'Battery' and 'Group A'. The footer contains the text 'GE LabWatch LT, All Copyrights Reserved.' and 'Logged In User: admin Thursday, November 08, 2012 | 3:35:42 PM'.

Figure 41: Monitoring Tab

3.1 The Monitoring Screen

The Monitoring screen, the first screen to appear once you have logged onto LabWatch LT, provides a concise overview of the various groups of sensors that make up a LabWatch LT system. As with the other major screens, the header lists the number of current unacknowledged alarms.

At the bottom of the screen, the Area series of buttons offers a scrolling list of the user-assigned alarm areas (groups). Any group with at least one unacknowledged alarm will flash red, while the others will remain blue. Users can create any number of individual alarm areas with any number of tags. (GE recommends defining areas with up to 30 tags for better and clearer depiction on a full screen view.)

When you click on any of these buttons, you can survey the status of the alarms assigned to this group in the center of the screen. Users can display all areas, or up to four groups on the screen at any one time, in three different views — **List** (tabular data, as shown in Figure 41 on the previous page), **Graph** (a color-coded graph of the individual tags), and **Floor** (displaying tag icons superimposed over a map of the facility floor plan). To determine the number of areas displayed on the monitor at any one time (from one to four), click on the appropriate button in the Display View option.

For example, if you click on the two-pane button, a two-area screen appears, with the right screen empty. Click on the second group, and, with the mouse held down, pull the second group onto the window. The screen now appears similar to Figure 42 below.



Figure 42: Two-View Monitoring Screen

3.1 The Monitoring Screen (cont.)

A three-area screen opens a third window. . .



Figure 43: Three-View Screen

and the four-area screen supports four different groups and/or views.



Figure 44: Four-View Screen

3.1 The System Monitoring Screen (cont.)

For RF ValProbe loggers, if a sensor is OPEN CIRCUIT, OVER range or UNDER range, the value will show up as ?? on the System Monitoring screen and it will have a COMM alarm.

Users can rearrange a List by clicking on the Column Layout drop-down list. They can then click or unclick checkboxes to show or hide particular alarm columns. In addition, they can click on the Status or Description drop-down lists to select particular tags to display, or the tags that are less than, equal to, or greater than a particular value.

To alter the description or status of a given tag, click on the tag to open the Tag Maintenance screen. Here you can review trends and tabular data, and edit the alarm data.

At the top of the screen, six tabs enable navigation among the major areas of LabWatch LT (Figure 45 below).



Figure 45: Navigation Tabs

- The **Graphing** tab allows you to select groups and tags to create graphs, as well as to determine the parameters, limits and appearance of the graph.
- The **Alarms** tab opens the Alarms window, in which you can review and acknowledge alarms. You can also view the alarm history for a particular tag since midnight of the current day (up to a maximum of 24 hours) by expanding the alarm row in the list.
- The **Audit** tab provides a running list of audit trail events.
- The **Reports** tab enables you to create daily, historical and Mean Kinetic Temperature (MKT) reports, along with single tag reports, audit trail reports and calibration reports, from the monitored data.
- The **Configuration** tab equips the Administrator to add and edit users and user passwords, set up telephone and e-mail contact configurations, enable and disable alarms, and access the Tag Configurator.
- From these other screens, the **Monitor** tab enables returning to the Monitoring screen.

3.1 The System Monitoring Screen (cont.)

At the right, the **Comments** button allows you to add comments at any time. When you click on this button, it turns yellow and the Comments window (Figure 46 below) opens.



The image shows a software window titled "Comments" with a blue header bar containing the GE logo. Below the header, there are three input fields: "USER ID", "PASSWORD", and "COMMENTS". The "COMMENTS" field is a large text area with a vertical scrollbar on the right side. At the bottom right of the window, there are two buttons: "OK" (yellow) and "CANCEL" (blue).

Figure 46: Comments Window

When you have finished, click **OK** to save the comments and close the window, or **Cancel** to close the window without saving the comments.

3.2 Views on the Monitoring Screen

3.2.1 The List View

When you first open the Monitoring screen, the default view will be the List View, (Figure 41 on page 39), a list of tags and values in table format. As with other views, you can select up to four groups to display on the screen at one time — or you can display one or more groups in other views (graph or floor). In the List view, the alarm columns include **Tag**, **Status**, **Lo** and **LoLo** Limits, **Hi** and **HiHi** Limits, **Value** (the current value for the alarm), **Is Alarm Enabled** (indicating whether a given alarm is enabled) and the **Description**.

Note: *You cannot enable an alarm in this window. To enable an alarm, go to page 51.*

Users can rearrange a List by clicking on the Column Layout drop-down list. They can then click or unclick checkboxes to show or hide particular alarm columns. Users can navigate to other screens and tabs by click on the List View grid header. For example, if the **Status** column header is clicked, then the user will be taken to the Alarm tab. Clicking on **Limit** columns and **Is Alarm Enabled** column will launch the Alarm Configuration tab of the Tag Management screen. Clicking on the **Tag Name** and **Value** column will launch **Trending** and **Tabular Data** in the Tag Management Screen.

Various alarm statuses are color-coded:

- red for Hi (High)
- burgundy for HiHi (High High)
- aqua for Lo (Low) sensor alarm and low battery alarm
- blue for LoLo (Low Low)
- yellow for loss of communication (COMM).
- green for the normal condition.

Note: *If necessary, you can change the color code for the above alarm conditions. See page 96.*

For RF ValProbe loggers, if a sensor is OPEN CIRCUIT, OVER range or UNDER range, the value will show up as “???” on the Monitoring screen and it will have a COMM alarm.

3.2.1 The List View (cont.)

You can rearrange a List by clicking on the Column Layout drop-down list. Then you can click or unclick checkboxes to show or hide particular alarm columns. You can also rearrange the order of the columns by dragging the column headers, and sort the columns on the list in ascending or descending order by clicking on column headers. If you click on arrows alongside the **Status** or **Description** drop-down lists, you can select particular units to display, or the tags that are less than, equal to, or greater than a particular value. To add or subtract screens with other views or groups, click on the Display View button with the desired number of views. To switch to another view, go to the **View By** drop down list in the upper left corner, and click on another view option.

3.2.2 The Graph View

To access a Graph view of a selected group on the Monitoring screen, go to the **View By** drop down list in the upper left corner, and click on the **Graph View** option. The screen converts to a view of the data in graphical format.

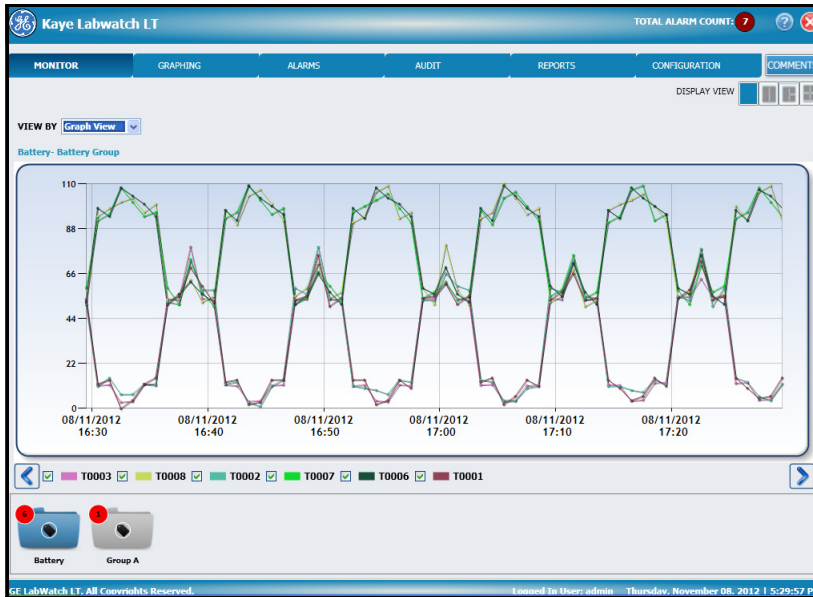

Figure 47: Graph View of Monitoring Screen

Each graphed tag is designated by a particular colored line, with the key in the upper right corner. Clicking on a given line opens a popup box with the sensor name, time/date stamp and current reading.

You can zoom into an area on the graph by selecting the area with the mouse and the scrollbars that appear. To zoom out, click on the - (minus) button on the scrollbars.

Note: *The graph view displays only the readings of the past hour.*

You can view up to four groups by clicking on the number of views in the Display View button in the upper right.

3.2.3 The Floor View



Figure 48: Floor View, Sensors Only

To access a Floor view of a selected group on the Monitoring screen, go to the **View By** drop down list in the upper left corner, and click on the **Floor View** option. The screen (Figure 48 above) converts to a view of the sensor data for the specified group, with tag name and current reading in blinking icons. However, you can add more specific floor information by importing a floor plan onto the screen and superimposing the tag data icons. Click on the **Floor Plan Settings** button. The Floor Plan Settings window (Figure 49 below) opens.



Figure 49: Floor Plan Settings Window

3.2.3 The Floor View (cont.)

To import the floor plan, click on the **Browse** button and locate the desired plan (in bmp or jpeg format). When you have added the plan, click **OK**. The screen now appears similar to Figure 50 below.



Figure 50: Floor Plan with Sensors

Click and drag the tag icons to the desired locations. When you have finished, click **Save Floor Plan**. Now you can view the tag data in its approximate location on the floor.

As with the List and Graph Views, you can view up to four groups by clicking on the number of views in the Display View button in the upper right.

3.3 Viewing Tag Data in Detail – The Tag Maintenance Screen

When you click on the tag line of a particular tag in the System Monitoring window, the Tag Maintenance screen opens. This screen offers three tabs for viewing the most current alarm data:

3.3.1 The Trending Tab

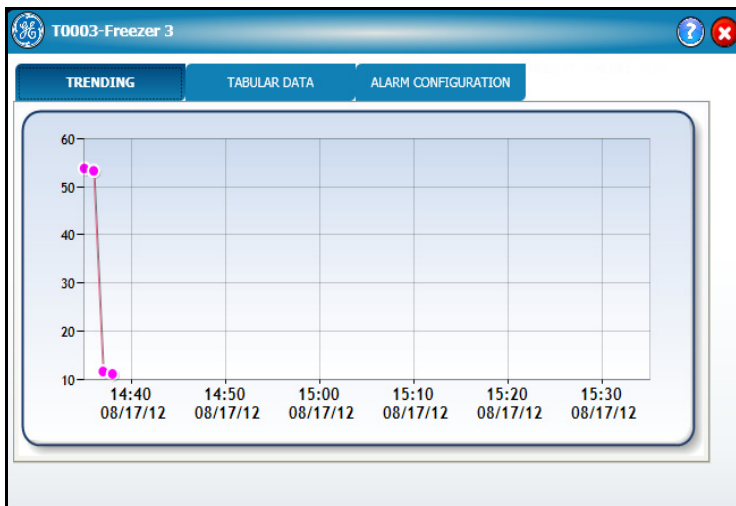

Figure 51: Trending Tab

The tab that initially appears, **Trending**, opens a live trend of the selected point. It appears blank when first opened, but then updates at 10-minute intervals. At the top of the screen, it displays the tag name, description and current value. If the tab remains open, it continues to collect and display data, allowing scrolling in the predetermined minutes. If you move the cursor to a particular point on the graph, a popup displays the date, time and value for a specific point.

Note: *Trending data only covers readings for the past hour.*

3.3.2 Tabular Data for a Tag

TAG ADMINISTRATION : T0008-Freezer 8

TRENDING TABULAR DATA **ALARM CONFIGURATION**

ALARM SETPOINTS

ENABLE

GROUP Battery

	ALARM LIMIT	ALARM DELAY (hh:mm)
LOLO	<input type="text" value="10.00"/>	<input type="text" value="00:00"/>
LO	<input type="text" value="15.00"/>	<input type="text" value="00:00"/>
HI	<input type="text" value="90.00"/>	<input type="text" value="00:00"/>
HIHI	<input type="text" value="100.00"/>	<input type="text" value="00:00"/>

SAVE CHANGES

Figure 52: The Tabular Data Tag

The second tab, **Tabular Data**, presents the real-time data for the tag in a Date/Time and Value table for the tag data. A drop-down list at the bottom of the tab enables you to display data over the following past durations in 1-minute increments (only):

- 5, 10 and 30 minutes
- 1, 2 and 12 hours
- 1 day, 2 days
- 1 week
- 1 month

3.3.3 The Alarm Configuration Tab

The figure displays two screenshots of the 'ALARM CONFIGURATION' tab in the Kaye LabWatch LT software. Both screenshots show the 'ALARM SETPOINTS' section for a specific tag.

Top Screenshot: TAG ADMINISTRATION : T0008-Freezer 8

- ENABLE:**
- GROUP:** Battery
- ALARM LIMIT:**
 - LOLO: 10.00
 - LO: 15.00
 - HI: 90.00
 - HIHI: 100.00
- ALARM DELAY (hh:mm):**
 - LOLO: 00:00
 - LO: 00:00
 - HI: 00:00
 - HIHI: 00:00
- SAVE CHANGES:** Button

Bottom Screenshot: TAG ADMINISTRATION : T0007-Freezer 7

- ENABLE:**
- GROUP:** Battery
- DELAY:** 0:00:00
- ALARM MODE:** [Dropdown menu]
- SAVE CHANGES:** Button

Figure 53: The Alarm Configuration Tab

3.3 The Alarm Configuration Tab (cont.)

The third tab in the Tag Maintenance screen, **Alarm Configuration**, equips you to enable, or specify alarms for a specified tag. Click (or clear) the **Enable** check box at the top to enable (or disable) alarms for a specific tag.

The **Group** line below identifies the group to which the tag belongs.

Eight text boxes below allow you (if you have appropriate permissions) to enter the **Alarm Limits** and **Alarm Delays** (in minutes) for the LOLO, LO, HI and HIHI alarms. However, if the tag type is a digital input, then you will be able to enter only the delay and alarm mode fields. When you have completed entering changes, click the **Save Changes** button.

Chapter 4. Graphing Tag Data

When you click on the Graphing tab from the Main Menu, you can set up a graph with specified groups and tags, and then establish the duration, appearance and limits of the graph. You can display one or two graphs at any one time, as shown in Figure 54 below and Figure 55 on the next page.



Figure 54: Single Graph View

A Graph Tooltip (shown above) allows users to review sensor readings that appear at a given point in time on the graph. To display the Tooltip, click on the graph at a particular point on the X-axis. A red vertical line will appear next to the Tooltip, which lists the tags and their readings for that particular time.



Figure 55: Dual Graph View

4.1 Configuring the Graph – the Chart Configuration Screen

On the Chart Configuration screen, you can enter the criteria and options (tags and groups, multiple Y axes, and limit lines) required for generating a single or double graph.

4.1.1 Entering Content

The first tab, **Tags**, displays the Groups and their tags you can select to generate a single graph or double graph. Click the checkbox for the groups and/or tags you need on the graph, and then select a template from the drop-down list.

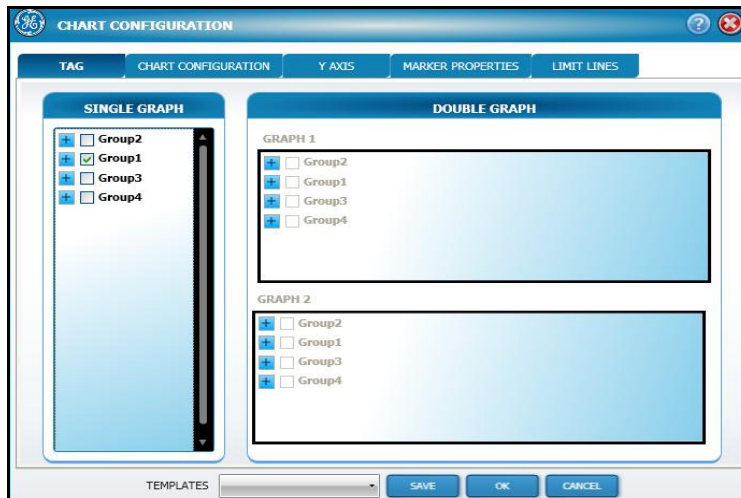

Figure 56: Groups and Tags

Click on the expansion box (+) to open the list of tags associated with each group. Click on the checkboxes for each group or tag you want to plot. Follow the same procedure to select each group and/or tag for comparison. When you have finished, click **OK**.

Note: Only 20 tags can be selected for each type of graph, i.e., Single Graph, Graph1 and Graph2.

4.1.2 Determining the Graph Appearance – Chart Configuration



Figure 57: The Chart Configuration Tab

On the Chart Configuration tab, you can specify the basic parameters of one or two charts that will appear on the Graphing screen.

1. First, select the **Data Retrieval** mode: click on either the Real-time or Historical option button.
2. Next, click on the **Calendar** button to open a calendar and select the **Start Date/Time** for either or both charts. You can click on the date on the calendar or enter the date/time in the text box.
3. In the same manner, select the **End Date/Time** for either or both charts.
4. Click on the **Sampling Mode** drop-down list to enter one of four sampling modes: **Sample/Lab**, **High Value**, **Low Value** or **Average**.
 - d. **Sample/Lab**: The graph will plot the sample value every minute for the selected duration. You can select chart duration for this mode to define the number of hours the chart will cover on the x-axis.
 - e. **High Value**: The graph will display the maximum sample values. The maximum value to be plotted depends on the duration selected. For example, if the duration (determined by Start Date and End Date) is 3 days, then the maximum value out of every 3 samples for 3 days is considered and plotted on the graph. Similarly, if the duration is 7 days, then the maximum value out of every 7 samples for 7 days is considered and plotted on the graph.

4.1.2 Determining the Graph Appearance – Chart Configuration (cont.)

- f. **Low Value:** The graph will display the minimum sample values.
 - g. **Average:** The graph will display the average sample values.
5. Finally, pull down the **Chart Duration** drop-down list and click on the number of hours the chart (s) will cover.

4.1.3 The Y Axis Tab



Figure 58: The Y Axis Tab

Click on the **Y-Axis** tab to set up the parameters for each of three Y axes.

1. For each axis, click the checkbox **Enable** if you want to apply that particular axis.
2. In the **Axis Name** text box, enter the name that will appear on the chart.
3. Click on the **Sensor Type** drop-down list to click on the type of sensor that will be displayed (temperature, humidity or auxiliary).
4. In the **Min** and **Max** text boxes, type in the lower and upper limits for the y axis.

4.1.4 Marker Properties

Use the **Marker Properties** tab to select the appearance of data markers on the chart.

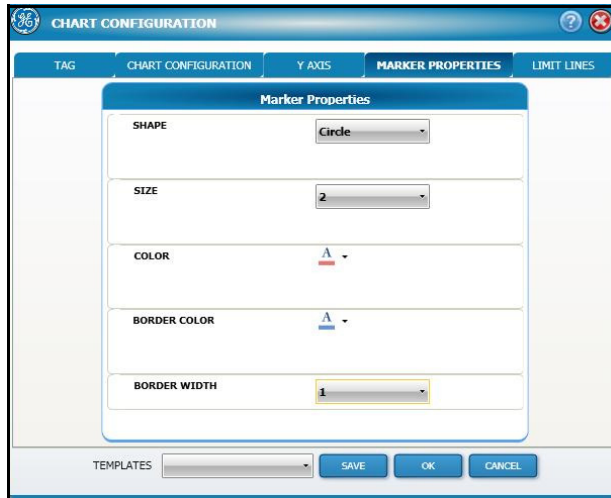

Figure 59: The Marker Properties Tab

5. Pull down the **Shape** drop-down list to select the shape of the marker (circle, square or triangle).
6. Pull down the **Size** drop-down list to click on the size of the marker (from 1 to 10).
7. Open the **Color** drop-down list and select the marker color.
8. Open the **Border Color** drop-down list and select the border color.
9. Pull down the **Border Width** drop-down list to click on the size of the border (from 1 to 10).

4.1.5 Limit Lines



Figure 60: The Limit Lines Tab

The **Limit Lines** tab allows you to set the values and appearance of the alarm limits on the chart. For each of up to three axes, enter the following parameters:

1. Click the checkbox **Enable** to enable any of the Y axis limit lines.
2. For each of the alarm limits (**HI-HI**, **HI**, **LO-LO** and **LO**), type in the desired value.
3. From the **Type** drop-down list, click on the line type required (solid, dash, etc.)
4. From the **Width** drop-down list, click on the desired width (from 1 to 10).
5. From the **Color** drop-down list, click on the desired color.

When you have completed entering parameters on the four tabs, click **OK**.

4.1.6 Graph Template

The chart configuration details can be saved and deleted. However, there is no provision for modifying a template.

To create a new template:

1. Fill all configuration details.
2. Click **ON**.
3. Click **Save**.

After successful saving, LabWatch LT displays a success message and the Chart Configuration window closes. The graph is drawn using these configurations.

To delete a template:

1. Select a template from the **Template** dropdown menu.
2. Click **Delete** from the dropdown menu.

4.1.7 Plotting a Graph for Multiple Y-Axis

In case of multiple Y axes, each axis gets a color based on the sensor type selected on the axis. The trend line has shades of color based on the type of sensor. In this way users can determine which trend line belongs to which axis.





Tag Type	Color Shade
Temperature	Blue
Humidity	Green
Auxiliary	Red
Digital Input	Yellow
Battery	Brown

4.2 Basic Chart Controls



Figure 61: Graph Controls

Below each chart, a series of buttons allows you to further customize the chart appearance.

- The **Zoom** buttons  allow you to zoom in and out of particular locations on the chart.
- The **Refresh** button  allows you to update the chart with the most recent data.
- The **Save** button  allows you to save the graph as a jpeg or bmp image file.
- The **Print** button  allows you to print out the graph on your default printer.

4.2 Basic Chart Controls (cont.)

- The **Color** button  allows you to apply one of a number of basic colors as a gradient background to the chart. For example, if you want a green background, click on the button, and a pull-down palette opens. Click on a shade of green, and the background changes color, as shown below.

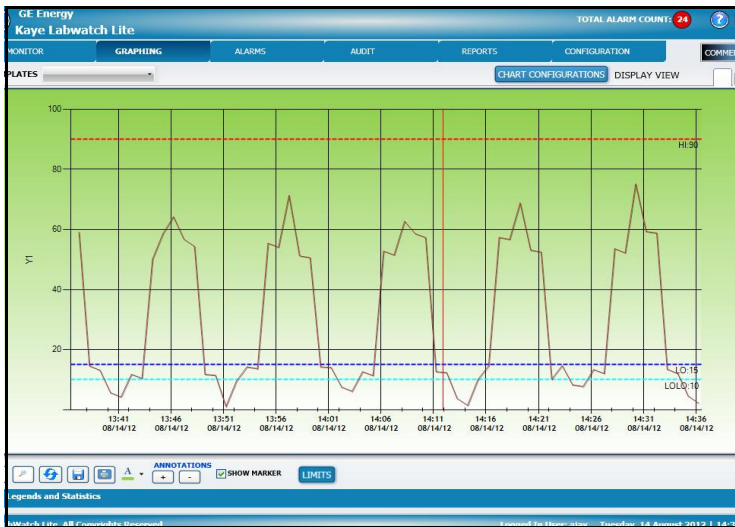



Figure 62: Graphing Screen with Changed Gradient

- The **Annotation** buttons  enable you to add or remove annotations (titles and comments) to the chart or to individual data points. The first annotation is normally the title, and subsequent annotations are comments.
- Click on the Show Marker checkbox  to enable the chart to display the marker. A graph without markers appears similar to Figure 63 on the next page.

4.2 Basic Chart Controls (cont.)

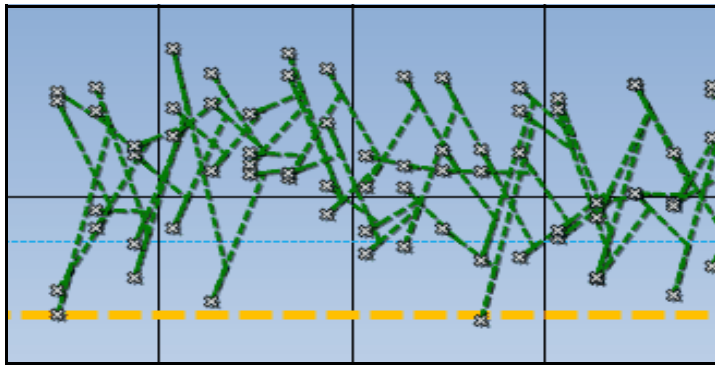

Figure 63: Graph without Markers

When you click **Show Markers**, the markers pinpoint the data readings (Figure 64 below).

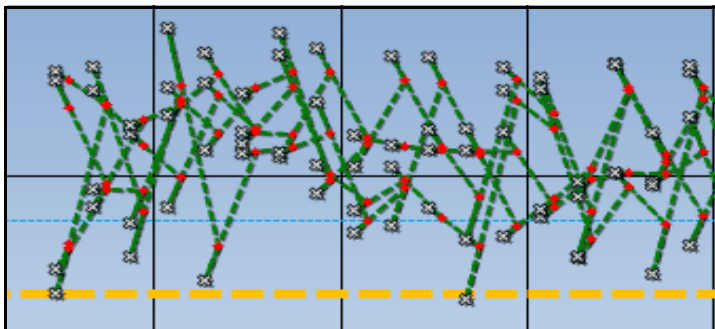



Figure 64: Graph with Markers)

Click on the **Limits** button  to display the LOLO, LO, HI and HIHI limits as lines on the graph for a single tag.

Note: *The Limits button remains disabled if you select two or more tags in the Legends and Statistics list. It is enabled only if a single tag is selected.*

4.2 Basic Chart Controls (cont.)

At the bottom of the screen, click on the **Legends and Statistics** arrow to open a list of tags, along with their time stamps, associated colors, descriptions and most recent readings.

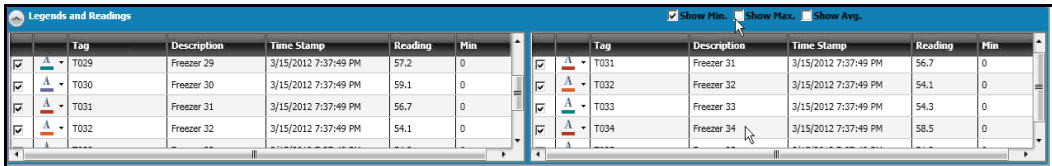

Tag	Description	Time Stamp	Reading	Min
T029	Freezer 29	3/15/2012 7:37:49 PM	57.2	0
T030	Freezer 30	3/15/2012 7:37:49 PM	59.1	0
T031	Freezer 31	3/15/2012 7:37:49 PM	56.7	0
T032	Freezer 32	3/15/2012 7:37:49 PM	54.1	0

Tag	Description	Time Stamp	Reading	Min
T031	Freezer 31	3/15/2012 7:37:49 PM	56.7	0
T032	Freezer 32	3/15/2012 7:37:49 PM	54.1	0
T033	Freezer 33	3/15/2012 7:37:49 PM	54.3	0
T034	Freezer 34	3/15/2012 7:37:49 PM	58.5	0

Figure 65: Legends and Statistics

Click on another tab at the top of the screen to exit the Graphing screen.

Chapter 5. Monitoring Active Alarms

Accessible when you click on the **Alarms** tab, the Alarms screen provides a list view of all currently unacknowledged alarms triggered by the sensors monitored by LabWatch LT.

TIME IN	TAG NAME	STATUS	LOLO LIMIT	LO LIMIT	HI LIMIT	HIHI LIMIT	VALUE	GROUP	DESCRIPTION
25/09/2012 20:45:39	T0001	LOLO	10	15	90	99	11 °C	Battery	Freezer 1
25/09/2012 20:45:39	T0002	LOLO	10	15	90	100	11 mA	Battery	Freezer 2
25/09/2012 20:45:39	T0003	LOLO	-5	20	70	80	13.80 CC	Battery	Freezer 3
25/09/2012 20:45:40	T0006	HI	10	15	90	100	96 °C	Battery	Freezer 6
25/09/2012 20:45:40	T0007	HI	10	15	90	100	99 mA	Battery	Freezer 7
25/09/2012 20:45:40	T0008	HI	10	15	90	100	91 V	Battery	Freezer 8
25/09/2012 20:45:40	T0011	COMM	10	15	90	100	?? °C	Battery	Freezer 11
25/09/2012 20:45:40	T0012	COMM	10	15	90	100	?? mA	Battery	Freezer 12
25/09/2012 20:45:40	T0013	COMM	10	15	90	100	?? V	Battery	Freezer 13
25/09/2012 20:45:40	T0016	HI	10	15	90	100	93 °C	Battery	Freezer 16
25/09/2012 20:45:40	T0017	HI	10	15	90	100	96 mA	Battery	Freezer 17
25/09/2012 20:45:40	T0018	HI	10	15	90	100	92 V	Battery	Freezer 18

Figure 66: The Alarms Tab

For each alarm, the list covers **Time In**, **Tag Name**, **Status**, **Lo** and **LoLo Limits**, **Hi** and **HiHi Limits**, **Current value**, **Description** and the associated **Group**.

If you click on the arrows alongside **Status**, **Description** or **Group**, a window opens in which you can click on the particular tag (status, or description) to display; you can also select particular specifications for values displayed, as shown in Figure 67 below.

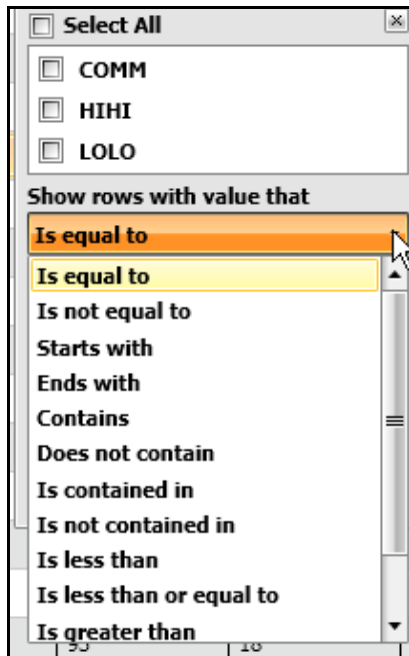

Figure 67: Filter Window

To remove or rearrange columns, click on the **Column Layout** arrow. The Column Layout window opens

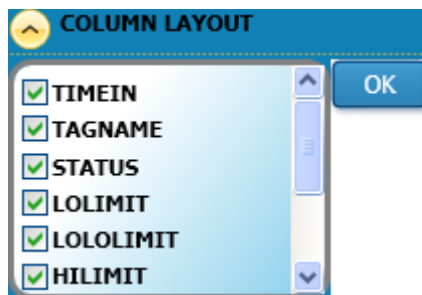

Figure 68: Column Layout Window

Clear the checkbox for any column you do not wish to view. To move a column further to the left or right, highlight the parameter in the list, and then click the **Move Up** or **Move Down** buttons to reposition the column. When you are satisfied, click **OK**. The Alarms screen reopens, with the highest column in the list at the far left, and other columns in descending order from left to right.

To acknowledge the current alarms, click the **Acknowledge** button at the bottom of the screen. Then follow the instructions below.

5.1 Acknowledging Alarms

When you click on the **Acknowledge** button from the Alarms window, the Acknowledge Alarms window opens.

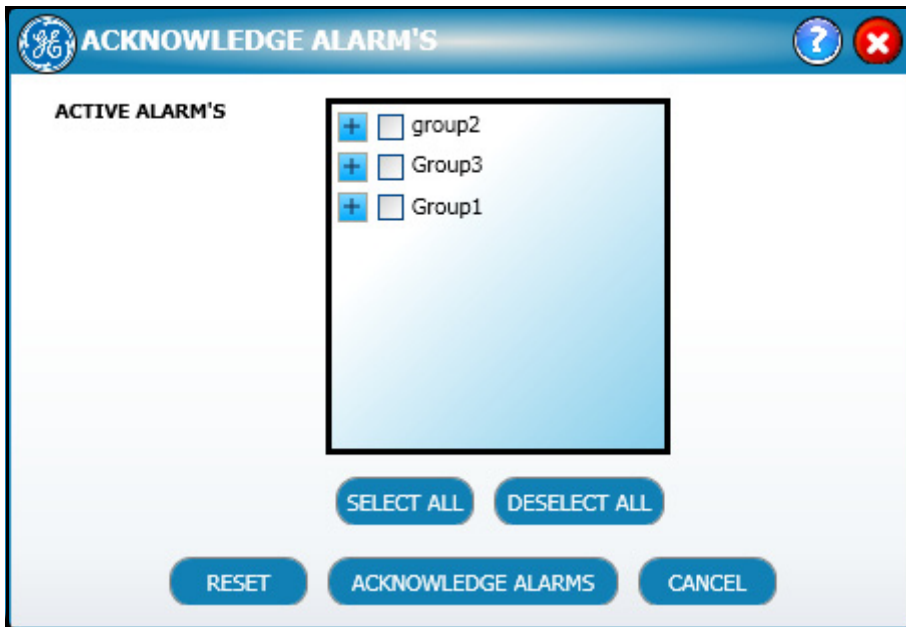

Figure 69: The Acknowledge Alarms Screen

5.1 Acknowledging Alarms (cont.)

Click on the checkbox for the group and/or tags you need to acknowledge. (You can also click on the **Select All** or **Deselect All** buttons.) To reset the alarms, click **Reset**. To acknowledge the alarms, click **Acknowledge Alarms**. A second window opens alongside the first.

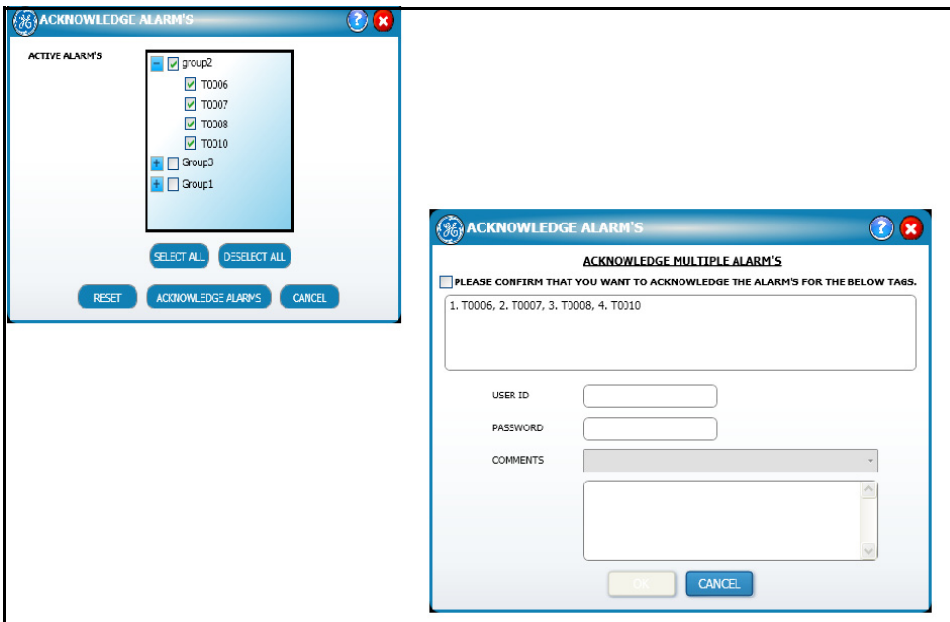

Figure 70: Acknowledge Alarms Windows

1. First, click the check box for the "Please confirm that you want to acknowledge the alarms for the below tag."
2. Next, enter your User ID and Password.
3. Finally, enter your Comments, either from the drop-down list or in the text box below.
4. Click the **OK** button to acknowledge the alarm.

Note: *If you do not have authorization to acknowledge this alarm, a popup window informs you that the entered user does not have authorization to acknowledge the alarm. Click **OK** to close the window, and **Cancel** to close the Acknowledge Alarms window.*

5.2 5.2 Viewing the Alarm History

To view the alarm history of a particular tag, click the + button for that tag in the far left column, as shown in Figure 71 below.

TIME	TAG NAME	ALARM TYPE	VALUE	COMMENTS	STATUS				
2012-08-17 12:50:54	T0011	COMM	10	15	90	100	73.1 C	Group3	Freezer 11
2012-08-17 12:50:54	T0012	COMM	10	15	90	100	62.7 RH	Group3	Freezer 12
	T0012	HI	59.4						Not Acknowledged.
	T0012	HI	57.7						Not Acknowledged.
	T0012	HI	??						Not Acknowledged.
	T0012	HI	??						Not Acknowledged.
	T0012	HI	61.4						Not Acknowledged.
2012-08-17 12:50:54	T0013	COMM	10	15	90	100	73.2 V	Group3	Freezer 13
2012-08-17 12:50:54	T0015	COMM	10	15	90	100	72.8 %	Group3	Freezer 15

Figure 71: Alarm History

Note: The screen displays the alarm history for a particular tag since midnight of the current day (for a maximum of up to 24 hours).

[no content intended for this page - proceed to next page]

Chapter 6. Viewing the Audit Trail

The screenshot shows the Kaye Labwatch LT interface with the 'AUDIT' tab selected. The table displays the following data:

USER ID	USER NAME	DATE	AUDIT EVENT	DESCRIPTION	COMMENTS
admin	administrator	09/20/2012 19:32:45	LOGINOK	SUCCESSFULLY LOGGED IN	
admin	administrator	09/20/2012 19:32:45	UISTARTUP	UI STARTUP AT Thursday, September 20, 2012	
admin	administrator	09/20/2012 19:19:43	UISHUTDOWN	UI SHUTDOWN AT Thursday, September 20, 2012	
admin	administrator	09/20/2012 19:19:27	SUCCESSFULLY LOGGED INTO	SUCCESSFULLY LOGGED INTO USER ACCOUNT SETTINGS	
admin	administrator	09/20/2012 19:19:20	LOGINOK	SUCCESSFULLY LOGGED IN	
admin	administrator	09/20/2012 19:19:19	UISTARTUP	UI STARTUP AT Thursday, September 20, 2012	
admin	administrator	09/20/2012 18:23:05	UISHUTDOWN	UI SHUTDOWN AT Thursday, September 20, 2012	
admin	administrator	09/20/2012 18:21:08	SUCCESSFULLY LOGGED INTO	SUCCESSFULLY LOGGED INTO SCHEDULE DETAILS	
admin	administrator	09/20/2012 18:19:23	LOGINOK	SUCCESSFULLY LOGGED IN	
admin	administrator	09/20/2012 18:19:22	UISTARTUP	UI STARTUP AT Thursday, September 20, 2012	
admin	administrator	09/20/2012 18:04:17	SUCCESSFULLY LOGGED INTO	SUCCESSFULLY LOGGED INTO USER VACATIONS	
admin	administrator	09/20/2012 18:03:51	SUCCESSFULLY LOGGED INTO	SUCCESSFULLY LOGGED INTO SCHEDULE DETAILS	
admin	administrator	09/20/2012 18:03:18	SUCCESSFULLY LOGGED INTO	SUCCESSFULLY LOGGED INTO SCHEDULE DETAILS	
system	systemuser	09/20/2012 18:00:19	Created Deafult User Account Settings	SCHEDULES ALLOWED PER USER is Assigned with 2	USRASET
system	systemuser	09/20/2012 18:00:19	Created Deafult User Account Settings	PASSWORD RESET AFTER DAYS is Assigned with 300	USRASET
system	systemuser	09/20/2012 18:00:19	Created Deafult User Account Settings	DISABLE ACCOUNT AFTER FAILED ATTEMPTS is Assigned with 3	USRASET
system	systemuser	09/20/2012 18:00:19	Created Deafult User Account Settings	REQUIRE STRONG PASSWORD is Assigned with False	USRASET
system	systemuser	09/20/2012 18:00:19	Created Deafult User Account Settings	MINIMUM PASSWORD LENGTH is Assigned with 6	USRASET
admin	administrator	09/20/2012 18:00:09	SUCCESSFULLY LOGGED INTO	SUCCESSFULLY LOGGED INTO USER ACCOUNT SETTINGS	
admin	administrator	09/20/2012 17:59:59	LOGINOK	SUCCESSFULLY LOGGED IN	
admin	administrator	09/20/2012 17:59:59	UISTARTUP	UI STARTUP AT Thursday, September 20, 2012	
admin	administrator	09/20/2012 17:53:42	UISHUTDOWN	UI SHUTDOWN AT Thursday, September 20, 2012	

At the bottom of the screen, it shows: GE LabWatch LT, All Copyrights Reserved. Logged In User: admin Thursday, September 20, 2012 | 07:32:56 PM

Figure 72: The Audit Screen

The Audit screen provides a list view of all audit events entered into the LabWatch LT audit trail. For each event, the list covers User ID, Date, Audit Event, Description, Comments and Tag Name. If you click on the arrows alongside some of the columns, a Filter window opens in which you can click on the particular item(s) you wish to display.

USER ID	DATE	AUDIT EVENT	DESCRIPTION	COMMENTS	TAG NAME
krish	2012-08-17 13:02:33	LOGINOK	SUCCESSFULLY LOGGED IN		
krish	2012-08-17 13:02:33	UISTARTUP	UI STARTUP AT Friday, 17 August		
krish	2012-08-17 12:45:42	MODIFIEDALARMCOLORCOI	UPDATED OK ALARM COLOR COD		
krish	2012-08-17 12:45:42	MODIFIEDALARMCOLORCOI	UPDATED COMM ALARM COLOR		
krish	2012-08-17 12:45:41	MODIFIEDALARMCOLORCOI	UPDATED HIHI ALARM COLOR C		
krish	2012-08-17 12:45:41	MODIFIEDALARMCOLORCOI	UPDATED HI ALARM COLOR COD		
krish	2012-08-17 12:45:41	MODIFIEDALARMCOLORCOI	UPDATED LOLO ALARM COLOR C		
krish	2012-08-17 12:45:41	MODIFIEDALARMCOLORCOI	UPDATED LO ALARM COLOR COD		
krish	2012-08-17 12:45:40	Modified Alarm COLORS	Reseted Alarm Colors.		
krish	2012-08-17 12:43:10	LOGINOK	SUCCESSFULLY LOGGED IN		
krish	2012-08-17 12:43:10	UISTARTUP	UI STARTUP AT Friday, 17 August		
u1	2012-08-17 12:42:59	LOGINFAILURE	INCORRECT LOGIN CREDENTIAL		
krish	2012-08-16 22:13:08	UISHUTDOWN	UI SHUTDOWN AT Thursday, 16		
u1	2012-08-16 22:13:00	LOGINFAILURE	INCORRECT LOGIN CREDENTIAL		
krish	2012-08-16 22:08:10	MODIFIEDUSER	MODIFIED USER ACCOUNT OF kr		
krish	2012-08-16 22:08:10	MODIFIEDUSER	MODIFIED USER ACCOUNT OF kr		
krish	2012-08-16 22:07:30	LOGINOK	SUCCESSFULLY LOGGED IN		

Figure 73: Filtered Events

You can also select particular limits for values displayed, as shown in Figure 74 below.

Figure 74: Audit Trail Events

To remove or rearrange columns, click on the **Column Layout** arrow. The Column Layout window opens.

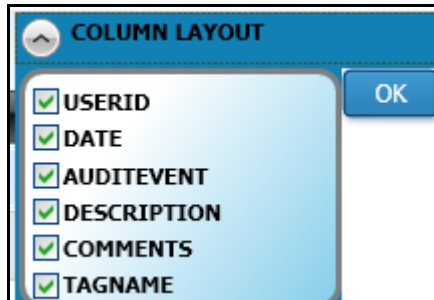

Figure 75: Column Layout Window on Audit Screen

Clear the checkbox for any column you do not wish to view. When you are satisfied, click **OK**. The Audit screen reopens, with the highest column in the list at the far left, and other columns in descending order from left to right.

Note: *The screen displays audit events since midnight of the current day, for a maximum of up to 24 hours. To create a detailed Audit Trail report, go to “Creating an Audit Trail Report” on page 83.*

[no content intended for this page - proceed to next page]

Chapter 7. Creating Reports

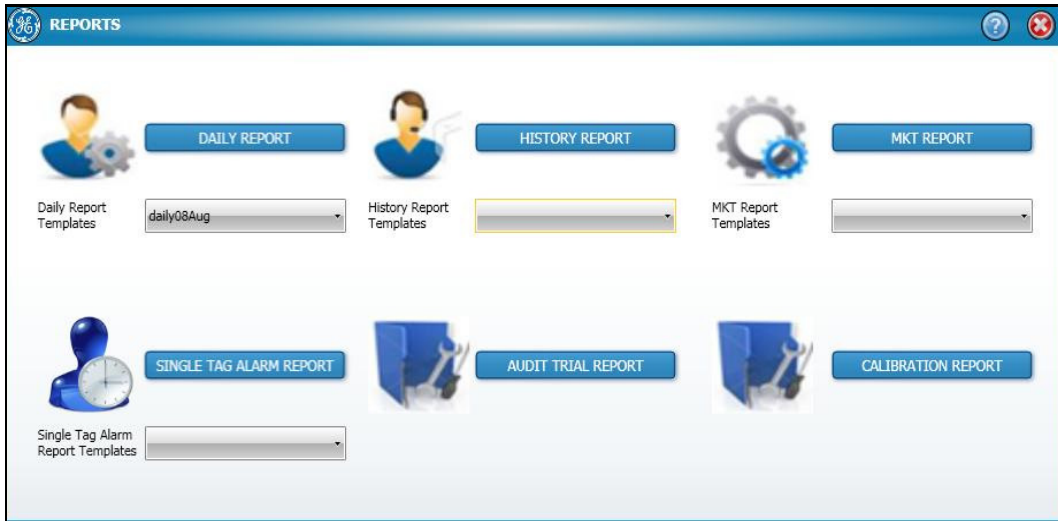

Figure 76: The Reports Tab

The LabWatch™ Lite Reporting System, available from the Reports tab of LabWatch LT, is a reporting and analysis tool that allows you to create reports from a secure database.

Note: *Entering the reporting system requires re-entry of a User ID and password.*

7.1 Report Types

LabWatch LT also lets you create the following reports from secure historical data:

Daily Report — LabWatch LT can be configured to automatically generate a Daily Report covering 24 hours of the day. The Daily Report contains each tag name, description and its hourly minimum, maximum, and average values over a specific 24-hour period.

Historical Data —The software creates an Historical Data Report using information from a secure database. Four types of Historical Data Reports are available: Values, Period Summary, Min/Max/Avg and Alarm. You can request a Values report that includes all values for selected tags at specified intervals over a defined period of time. You can also filter tag values by defining upper and lower limits. Values that exceed the specified upper limit and those values that fall below the specified lower limit are included in the report and marked with High or Low.

With a Min/Max/Avg report, you obtain the minimum, maximum, and average values for selected tags at specified intervals over a defined period of time. These can be used to produce daily or weekly reports.

The Alarm report displays the Alarm and Audit history for the selected tag(s).

Mean Kinetic Temperature (MKT)* — MKT is the isothermal temperature that corresponds to the kinetic effects of a time temperature distribution. The MKT calculation produces a single value that characterizes the effect of fluctuating temperatures on long-term product storage by weighing higher temperatures more heavily than lower ones. This is appropriate because product degradation occurs at an accelerated rate at higher temperatures.

LabWatch LT extracts data from the historical data files, performs an MKT calculation on the selected inputs, and reports the result in an MKT Report.

Single Tag Alarm Report— LabWatch LT can also create an alarm report for a single tag for a specified single day. It contains Alarm and Audit history for a selected tag for the selected day.

Audit Trail Report —You can create an Audit Trail report for specified groups or tags, including all audit trail events or those you specify.

7.1 Report Types (cont.)

Calibration Report — LabWatch LT also enables creation of current or historical calibration reports for specified groups or tags.

7.2 Reporting Operation and Benefits

LabWatch LT provides the following benefits:

- Secure encrypted audit trails, which meet FDA guidelines for electronic records and data (FDA Regulation 21 CFR part 11)
- An alarm log that chronologically records every event and operator action
- Ability to quickly sort or query the alarm data by tags and tag descriptors over a defined time period
- User name and password controlled access
- User can select only 100 tags for a report
- If the criteria for generating report results in a large set of records, the system prompts the user to tweak the criteria (e.g., a large date range).

7.3 Creating a Daily Report

To create a Daily Report, first click on the LabWatch LT Reports tab at the top of the screen, and then on the **Daily Report** button. The **Generate Daily Report** window opens (Figure 77 below).

Figure 77: Generate Daily Report

1. Select a template from the drop-down **List of Saved Templates** (based on previous reports that have been saved as templates).
2. Click on the **Group(s) and Tag(s)** that you need to include. You can include individual tags within a group by clicking on the expansion box, clearing the Group checkbox, and clicking the checkboxes alongside the individual tags. To simplify selection, you can also click the **Select All** or **Deselect All** buttons.
3. Click on the **Start Date** calendar and select the desired date and time. Repeat this procedure for the **End Date**.
4. If you want a graph at the end of the report, click the **Add Graph** checkbox.
5. In the associated text boxes, enter the text that will appear as the **Report Header**, the **Report Page Header** and the **Report Page Footer**.
6. Click on **Generate Report** to create the report, or on **Reset** to clear the entered data and all checkboxes. If you want to save this report as a template (adding it to the List of Saved Templates), click **Save Template**.

7.4 Creating a Historical Report

Generating historical reports is very similar to generating daily reports. Click on the LabWatch LT **Reports** tab at the top of the screen, and then on the **Historical Report** button. The Historical Report window opens.

Figure 78: Historical Reports Window

1. Select a template from the drop-down **List of Saved Templates** (based on previous reports that have been saved as templates).
2. Click on the **Group(s)** and **Tag(s)** that you need to include. You can include individual tags within a group by clicking on the expansion box, clearing the Group checkbox, and clicking the checkboxes alongside the individual tags. To simplify selection, you can also click the **Select All** or **Deselect All** buttons.
3. Click on the **Start Date** calendar and select the desired date and time. Repeat this procedure for the **End Date**.

7.4 Creating a Historical Report (cont.)

4. From the Report drop-down list, click on the desired report type: **Min/Max/Avg**, **Period Summary**, **Values** or **Alarm**.
5. For a Value report, if you want the report to remain within value limits, click the **Upper Limit** and/or **Lower Limit** checkboxes. Then enter the Upper and Lower Limit values in the associated text boxes. The generated Value report will show High or Low next to the value if they are not within given limits.
6. In the associated text boxes, enter the text that will appear as the **Report Header**, the **Report Page Header** and the **Report Page Footer**.
7. Click on **Generate Report** to create the report, or on **Reset** to clear the entered data and all checkboxes. If you want to save this report as a template (adding it to the List of Saved Templates), click **Save Template**.

7.5 Creating a MKT Report

Click on the LabWatch LT **Reports** tab at the top of the screen, and then on the **MKT Report** button. The Mean Kinetic Temperature Report window opens (Figure 79 below).

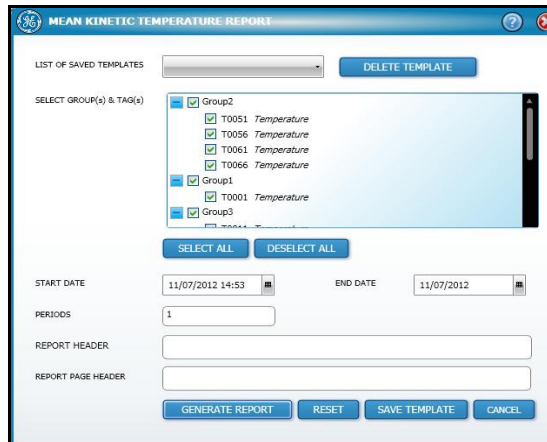

Figure 79: Mean Kinetic Temperature Report Window

1. Select a template from the drop-down **List of Saved Templates** (based on previous reports that have been saved as templates).
2. Click on the **Group(s)** and **Tag(s)** that you need to include. You can include individual tags within a group by clicking on the expansion box, clearing the Group checkbox, and clicking the checkboxes alongside the individual tags. To simplify selection, you can also click the **Select All** or **Deselect All** buttons.
3. Click on the **Start Date** calendar and select the desired date and time. Repeat this procedure for the **End Date**.
4. Enter the number of **Periods** you need the report to cover.
5. In the associated text boxes, enter the text that will appear as the **Report Header**, the **Report Page Header** and the **Report Page Footer**.
6. Click on **Generate Report** to create the report, or on **Reset** to clear the entered data and all checkboxes. If you want to save this report as a template (adding it to the List of Saved Templates), click **Save Template**.

7.6 Creating an Alarm Report for a Single Tag

To create a report for a Single Tag Alarm, click on the **Single Tag Alarm Report** button. The Single Tag Alarm Report window opens (Figure 80 below).

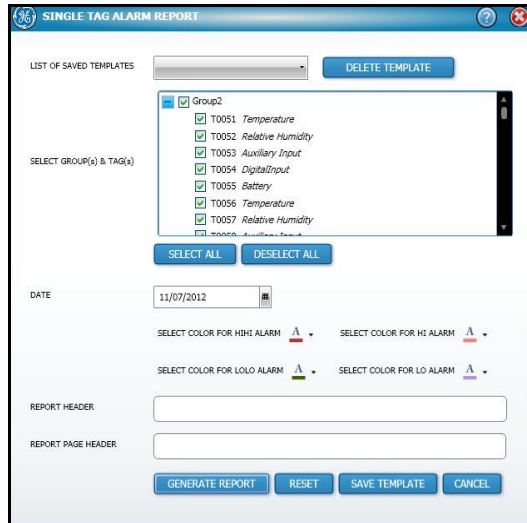

Figure 80: Single Tag Alarm Report

1. Select a template from the drop-down **List of Saved Templates** (based on previous reports that have been saved as templates).
2. Click on the **Group(s)** and **Tag(s)** that you need to include. You can include individual tags within a group by clicking on the expansion box, clearing the Group checkbox, and clicking the checkboxes alongside the individual tags. To simplify selection, you can also click the **Select All** or **Deselect All** buttons.
3. Click on the **Start Date** calendar and select the desired date on which the report begins.
4. To display a graph, click on the **Display Graph** checkbox. You can then select a color for the HIHI, HI, LO and LOLO alarms by opening the drop-down list and clicking the desired color.
5. In the associated text boxes, enter the text that will appear as the **Report Header**, the **Report Page Header** and the **Report Page Footer**.
6. Click on **Generate Report** to create the report, or on **Reset** to clear the entered data and all checkboxes. If you want to save this report as a template (adding it to the List of Saved Templates), click **Save Template**.

7.7 Creating an Audit Trail Report

To create an audit trail report, click on the **Audit Trail Report** button. The Audit Trail Report window opens.

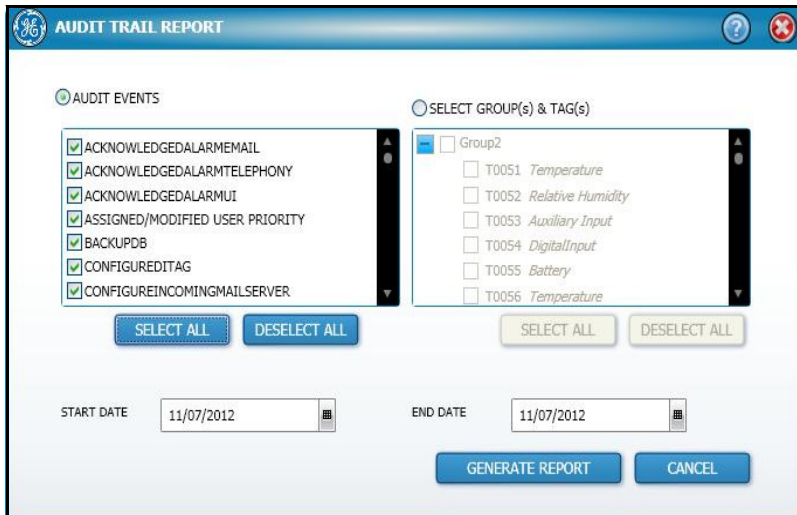

Figure 81: Audit Trail Report Window

1. Select the particular Audit Events that you need to include. First, click on the **Audit Events** option button. Then click on particular event types from the list window.
2. Click on the **Group(s) and Tag(s)** option button, and then on the groups and/or tags that you need to include. You can include individual tags within a group by clicking on the expansion box, clearing the **Group** checkbox, and clicking the checkboxes alongside the individual tags.
3. Click on the **Start Date** calendar and select the desired date. Repeat this procedure for the **End Date**.
4. Click on **Generate Report** to create the report, or on **Cancel** to clear the entered data and all checkboxes.

7.8 Creating a Calibration Report

The Calibration report tells the user when the user calibration was performed on tags and the current calibration settings for the tags. On the Calibration Report screen, you can generate either current or historical calibration reports.

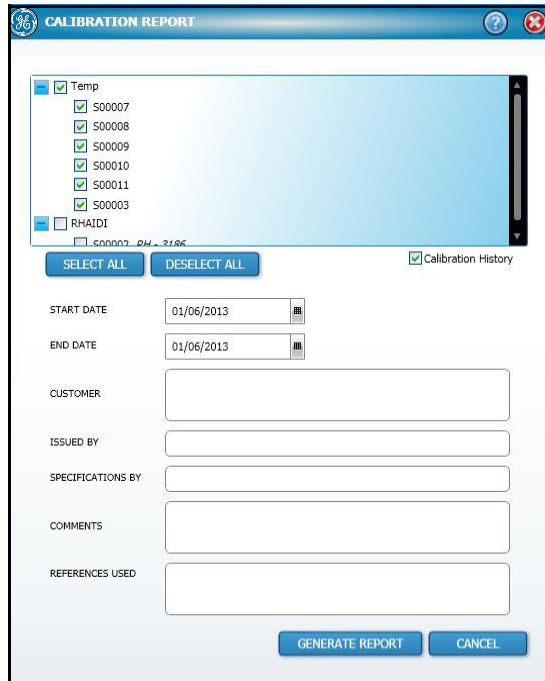

Figure 82: Calibration Report Window

1. First, click on the **Groups and Tags** that you need to include in the report. You can click on individual boxes, or use the **Select All** and **Deselect All** buttons.
2. To display the current calibration of the tags, leave the **Calibration History** box unchecked.
3. To display the calibration history of the tags, check the **Calibration History** box.
4. Click on **Generate Report** to create the report, or on **Cancel** to leave the window without creating a report.

7.9 The Report Viewer Toolbar

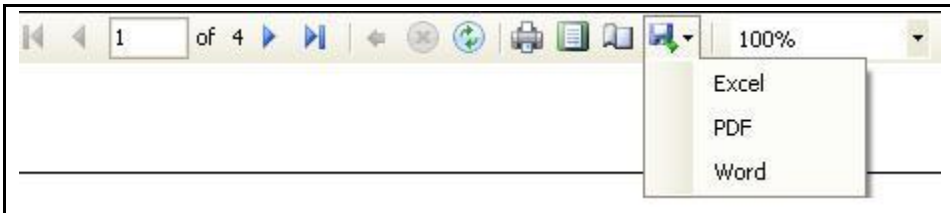
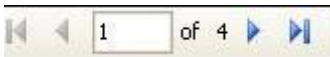



Figure 83: The Report Viewer Toolbar

LabWatch LT displays reports in the Report Viewer window, which has the toolbar shown above. The buttons may be disabled if not required (e.g., if the report is of one page, then the navigation buttons will be disabled).

The buttons are described below.





The navigation buttons enable a user to navigate to a desired page of the report.

The **Stop** button  permits a user to stop rendering the report.

The **Refresh** button  refreshes the report with the newest data.

The **Print** button  enables users to print the report.

The **Print Preview** button  allows users to view the report in a print layout.

The **Page Setup** button  opens the Page Setup window, where users can set the page size and page margin for the current report.

The **Zoom** drop-down menu  enables users to zoom the report as per the selected percentage.

7.9 The Report Viewer Toolbar (cont.)

The Export drop-down menu enables users to export a report to the desired format.

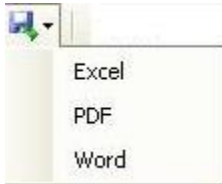

1. **Audit Report** - This report can be exported to Word, Excel and PDF file format.
2. **Other reports** - All the other reports can be exported to Excel and PDF file format.

IMPORTANT: *MS-Office and PDF reader software should be installed, to view the exported file.*

7.10 Deleting a Report Template

To delete a template:

1. Open the Report criteria screen
2. Select a template from the Template list.
3. Click the **Delete Template** button 
4. The appropriate success message is displayed.

IMPORTANT: *All report criteria screens having a Report Template have the Delete feature.*

Chapter 8. Configuring Kaye LabWatch LT

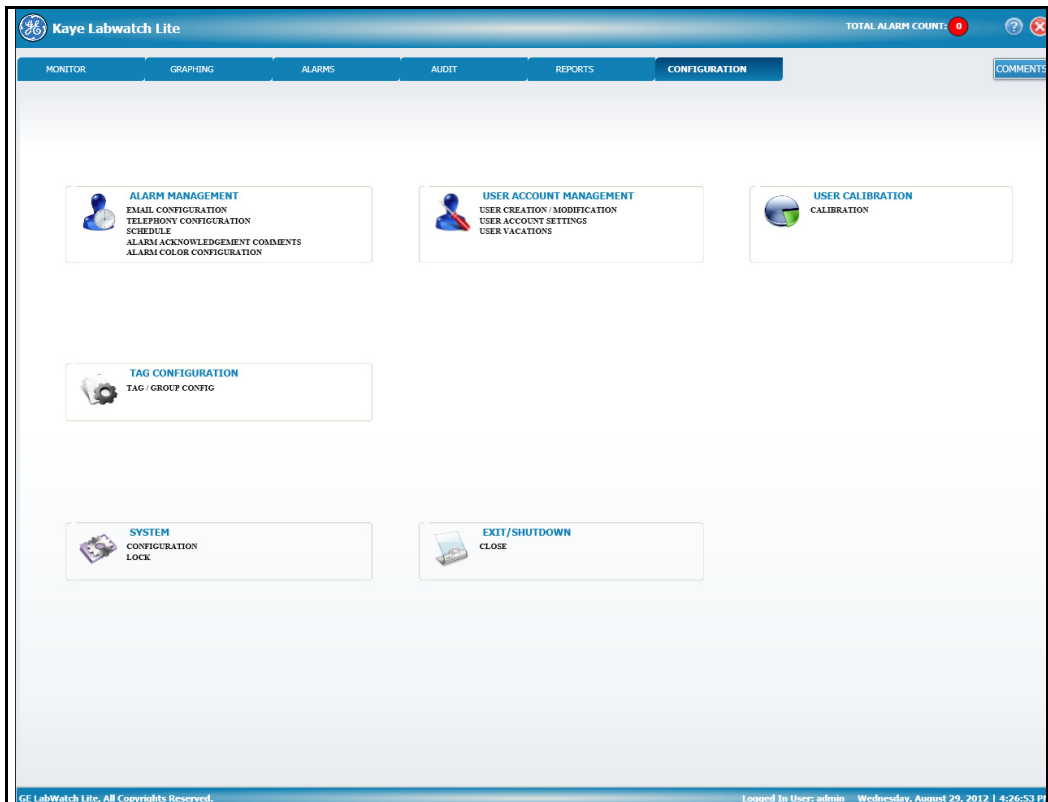

Figure 84: The Configuration Tab

On the Configuration screen (available by clicking on the **Configuration** tab), you can set up and manage alarm contacts (e-mail and telephone) and acknowledgements, user accounts, calibration records, tag and group configurations, and basic system display parameters.

Refer to the sections listed below for specific information on a configuration procedure.

- Email Configuration —page 89
- Telephony Configuration —page 92
- Schedules —page 94
- Alarm Acknowledgement Comments —page 95
- Alarm Color Configuration — page 96
- User Creation/Modification — page 98
- User Account Settings —page 101
- User Vacations —page 103
- User Calibration —page 104
- Tag/Group Configuration — page 106
- System Configuration — page 112
- Locking and Unlocking LabWatch LT —page 113
- Exit/Shutdown -- Click on **Close** and then log in to exit or close your session with LabWatch LT.

8.1 Configuring Email Contacts

8.1.1 Email Server Tab

In the Email Configuration window, the first tab, **Email Server**, equips you to set up the outgoing and incoming mail servers to transmit alarm messages.

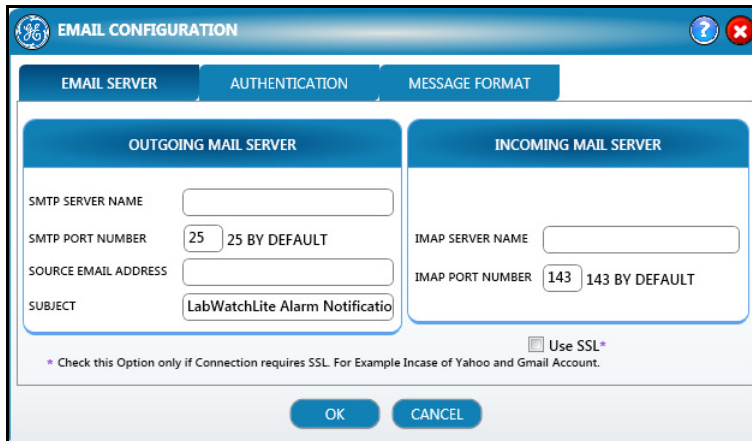

The screenshot shows the 'EMAIL CONFIGURATION' window with the 'EMAIL SERVER' tab selected. The window is divided into two main sections: 'OUTGOING MAIL SERVER' and 'INCOMING MAIL SERVER'. The 'OUTGOING MAIL SERVER' section includes fields for 'SMTP SERVER NAME', 'SMTP PORT NUMBER' (set to 25, with '25 BY DEFAULT' text), 'SOURCE EMAIL ADDRESS', and 'SUBJECT' (set to 'LabWatchLite Alarm Notificatio'). The 'INCOMING MAIL SERVER' section includes fields for 'IMAP SERVER NAME' and 'IMAP PORT NUMBER' (set to 143, with '143 BY DEFAULT' text). At the bottom, there is a checkbox for 'Use SSL*' with a note: '* Check this Option only if Connection requires SSL. For Example Incase of Yahoo and Gmail Account.' Below the form are 'OK' and 'CANCEL' buttons.

Figure 85: Email Server Tab

For the Outgoing Mail Server:

1. Enter the **SMTP Server Name** in the associated text box.
2. Enter the **SMTP Port Number** (25 by default) in the text box.
3. Enter the **Source Email Address** and the **Subject** in the text boxes.
4. Check **Use SSL** option for Gmail and Yahoo mail accounts.

For the Incoming Mail Server, enter the **IMAP Server Name** and the **IMAP Port Number** (143 by default).

8.1.2 The Authentication Tab

The next tab, **Authentication**, sets up the Name and Password by which a user can log into LabWatch LT to acknowledge alarms.

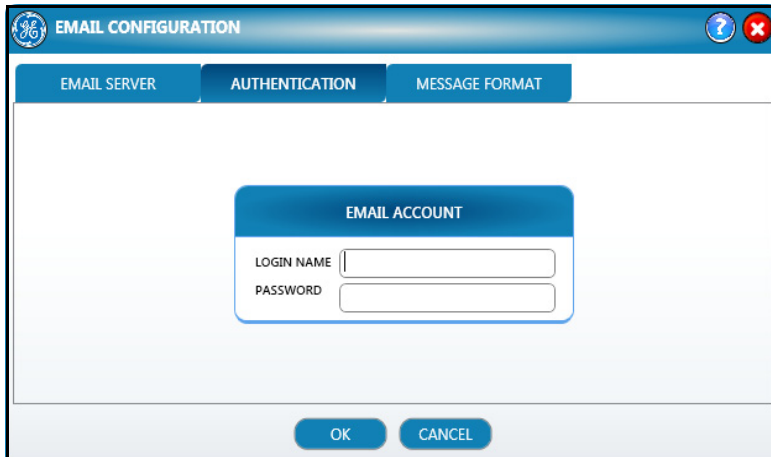

The screenshot shows a software window titled "EMAIL CONFIGURATION" with a GE logo in the top-left corner and help/question mark and close buttons in the top-right. Below the title bar are three tabs: "EMAIL SERVER", "AUTHENTICATION" (which is selected), and "MESSAGE FORMAT". The main content area contains a sub-dialog box titled "EMAIL ACCOUNT" with two input fields: "LOGIN NAME" and "PASSWORD". At the bottom of the main dialog are "OK" and "CANCEL" buttons.

Figure 86: The Authentication Tab

Enter the **Login Name** and **Password** that will access the account.

8.1.3 The Message Format Tab

The final tab establishes the **Message Format** for alarm messages.

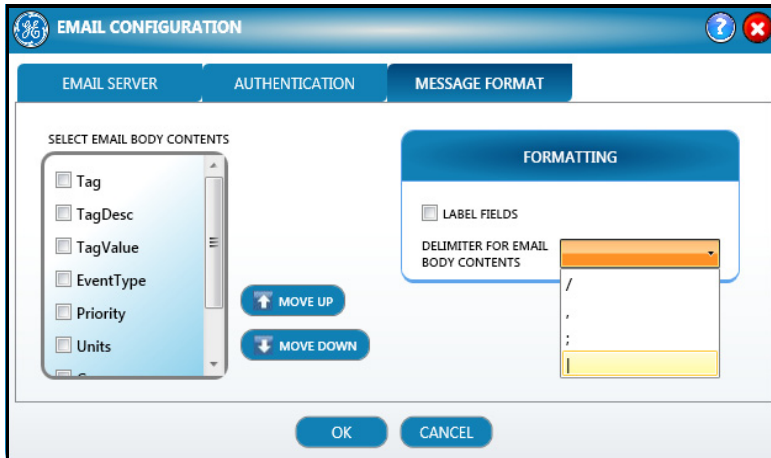

Figure 87: The Message Format Tab

At the left, select the **Email Body Contents** by clicking on the checkbox next to the parameter: **Tag**, **TagDesc**, **Tag Value**, **Event Type**, **Priority**, **Units**, and **Group**. You can also use the **Move Up** and **Move Down** buttons to arrange the order of the contents.

At the right, the **Formatting** pane enables you to **Label Fields** (by clicking the checkbox) and to select a **Delimiter for Email Body Contents** (semicolon, comma or slash) from the pull down menu.

When you have finished, click **OK** to save the entries and close the window, or on **Cancel** to close the window without entering the data.

8.2 8.2 Configuring Telephone Contacts

If you need to configure telephone dialing for LabWatch LT, click on **Telephony Configuration** in the Alarm Management section. The Telephone Dialer Configuration window opens.

8.2.1 The Voice Tab

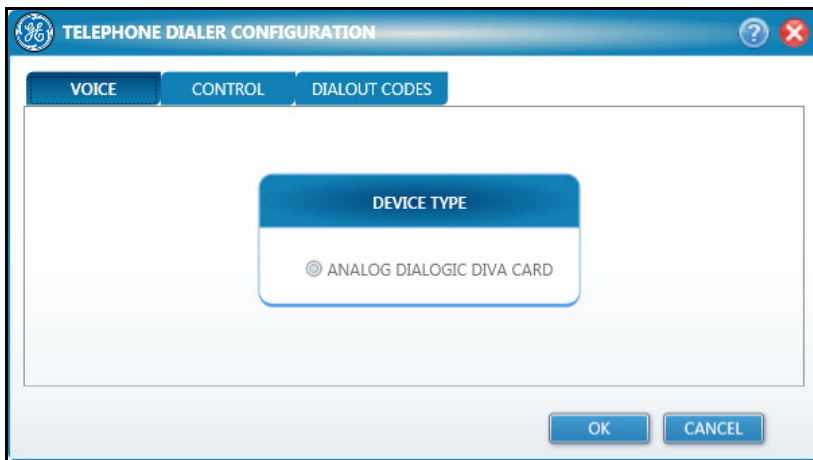

Figure 88: Voice Tab in Telephone Dialer Configuration

8.2.2 The Control Tab

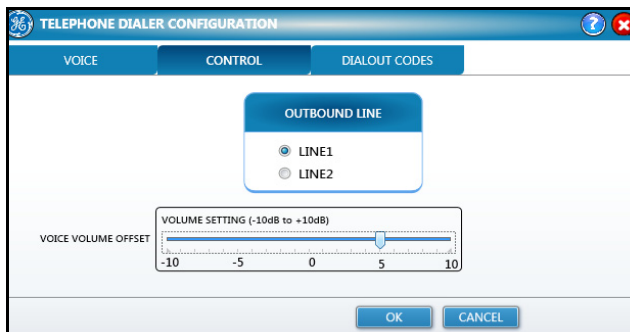

Figure 89: The Control Tab

The Control tab permits selection of the outbound line for sending phone messages, and the volume setting for these messages. In the Outbound Line box, click on the **Line 1** or **Line 2** option button to specify the telephone line. Use the sliding scale to set the appropriate **Volume Setting** (over a range from -10dB to +10dB).

8.2.3 The Dialout Codes Tab

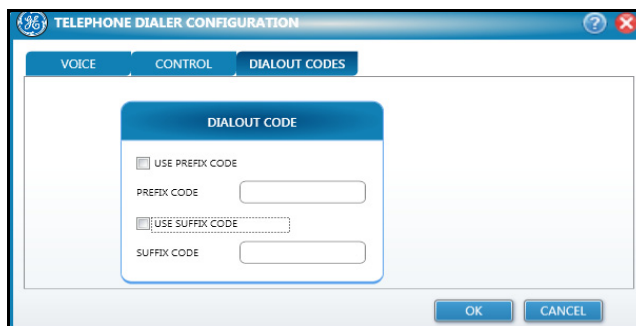

Figure 90: Dialout Codes

If you need dialout prefixes or suffixes to access outside lines, the Dialout Code tab enables you to record them. To add a Prefix Code or Suffix Code, click on the appropriate checkbox and enter the code in the text box.

When you have finished, click **OK** to save the entries and close the window, or on **Cancel** to close the window without entering the data.

8.3 Managing User Schedules

To set up, edit or delete a user schedule (that is, a time period during which LabWatch LT can contact specific users with messages), click on the **Schedule** option under Alarm Management. The Schedule window opens with the list of current schedules.

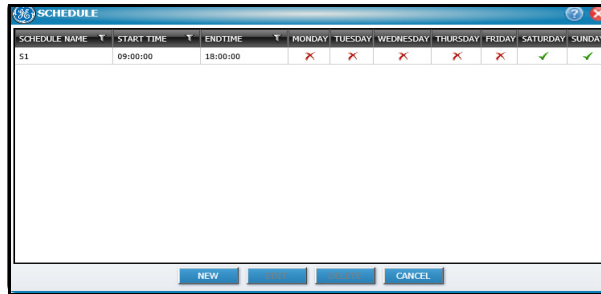

Figure 91: The Schedule Window

- To create a new schedule, click **New**. The New Schedule window opens.

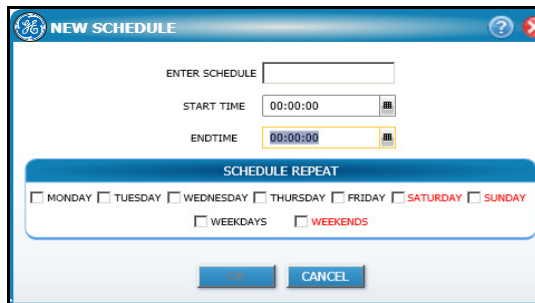

Figure 92: New Schedule Window

In the text box, enter the schedule name. Then use the drop-down hourly lists to specify the **Start** and the **End Time**, and the checkboxes to enter the days. When you have completed editing the schedule, click **OK**.

- To edit an existing schedule, highlight the schedule and click **Edit**.
- To delete an existing schedule, highlight the schedule and click **Delete**.
- To close the window, click **Cancel**.

8.4 Adding Predefined Acknowledgement Comments

You can add a list of up to five predefined comments to aid in easily classifying acknowledged alarms. To define these comments, click on **Alarm Acknowledgement Comments** under Alarm Management. The Alarm Acknowledgement Comments window opens.

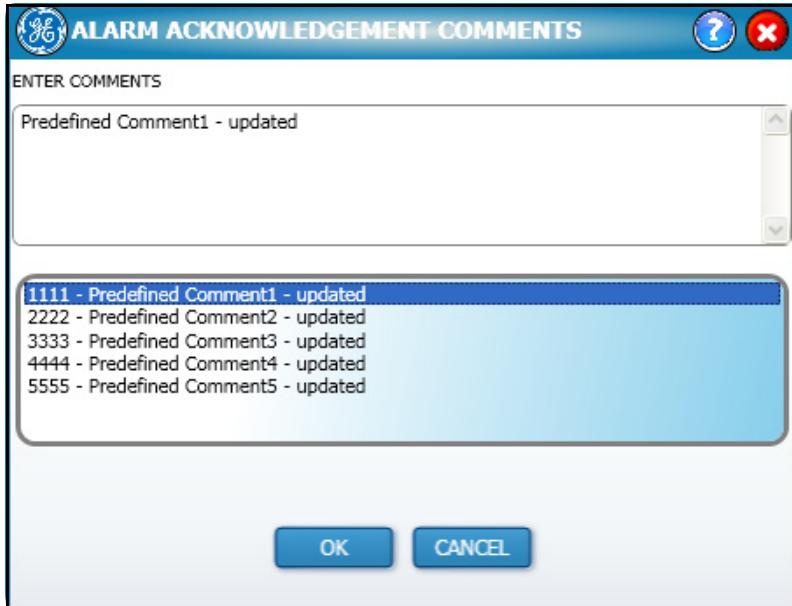

Figure 93: Alarm Acknowledgement Comments

Click on one of the five available comments. In the **Enter Comments** text box above, replace the “Predefined Comment” text with the desired text. When you have finished editing comments, click **OK** to save the new comments and close the window.

8.5 8.5 Configuring Alarm Colors

LabWatch LT has a standard set of colors to designate various types of alarms:

- red for Hi (High)
- burgundy for HiHi (High High)
- aqua for Lo (Low) sensor alarm and low battery alarm
- blue for LoLo (Low Low)
- magenta for an open circuit (disconnected sensor).
- yellow for loss of communication (COMM).
- green for the normal condition.

However, you can also substitute another color for any or all of the above. Under Alarm Management, click on **Alarm Color Configurations**. The Alarm Color Configurations window opens.



Figure 94: Alarm Color Configuration Window

To change any alarm color, click the arrow next to the color. A palette of available colors (Figure 95 on the next page) opens.

8.5 Configuring Alarm Colors (cont.)

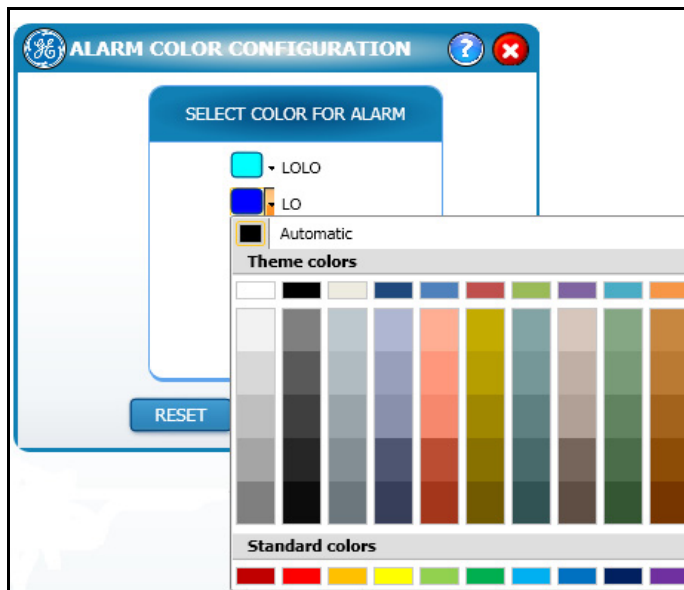

Figure 95: Palette of Alarm Colors

Click on the desired color to change the alarm color. When you have finished:

- Click **Reset** to return to the default colors.
- Click **OK** to save the changes and close the window.
- Click **Cancel** to close the window without saving any changes.

8.6 Adding or Editing Users

If you need to add or edit a user, click on **User Creation/Modification** under the User Account Modification heading. The User Creation/Modification window opens.

PERMISSION	VIEW	MODIFY
EMAILCONFIG	<input checked="" type="checkbox"/>	<input checked="" type="checkbox"/>
TELECONFIG	<input checked="" type="checkbox"/>	<input checked="" type="checkbox"/>
SCHEDULE	<input checked="" type="checkbox"/>	<input checked="" type="checkbox"/>
ALARMACKNOWLEDGMENTS	<input checked="" type="checkbox"/>	<input checked="" type="checkbox"/>

Figure 96: User Creation Window

On this screen, you can enter or change a user ID and user name, determine the user type, and select Permissions for the particular user.

The entire list of available users appears on the left. To edit an existing user, select the user from the list on the left.

To create a user:

- Enter a User Id and User Name in the appropriate text boxes.
- You can add **comments** for the created user.
- You can **reset the password** for a particular user (in cases where a password has been forgotten).
- You can **disable** a particular user. For a disabled user, all the controls except the comments and disable user checkbox are disabled. When a user is enabled, his or her password is also reset.

8.6 Adding or Editing Users (cont.)

- From the drop-down list, enter the **User Type**: Operator, System Administrator or Guest.
- System Administrator - Creates and maintains user accounts, sets site options and system preferences, locks and unlocks the system, backs up and restores user information, and views, prints, and maintains the audit trail. The System Administrator also performs Logger calibration.
- Operator - Can view screens and create reports. Operators can also have particular permissions if the System Administrator has set them up with specific permissions in this window.
- Guest - Can view screens, but cannot change any parameters.

In the lower left, you have a list of particular **Permissions** for a user. If you wish to grant permissions to view or modify parameters in the Configuration option, scroll to the appropriate option and click on the checkboxes for that permission.

The screenshot shows a web interface for user management. The title bar reads "USER CREATION / MODIFICATION". On the left is a "LIST OF USERS" panel. The main form contains the following fields and options:

- USER ID**: Text input field.
- USER NAME**: Text input field.
- COMMENTS**: Text area.
- USER TYPE**: Drop-down menu with "Operator" selected.
- EMAIL ID**: Four text input fields with a green "+" icon and a red "-" icon next to each.
- ACCESS CODE**: Text input field.
- USER PERMISSIONS**: A table with columns for PERMISSION, VIEW, and MODIFY.
- RESET PASSWORD**: Checkable option.
- DISABLE USER**: Checkable option.
- CHANGE PHOTO**: Text input field with a "BROWSE" button.
- TELEPHONY NO**: Four text input fields with a green "+" icon and a red "-" icon next to each.
- ACK CODE**: Text input field.

At the bottom of the form are "SAVE" and "NEW" buttons.

PERMISSION	VIEW	MODIFY
EMAILCONFIG	<input type="checkbox"/>	<input checked="" type="checkbox"/>
TELECONFIG	<input checked="" type="checkbox"/>	<input checked="" type="checkbox"/>
SCHEDULE	<input checked="" type="checkbox"/>	<input checked="" type="checkbox"/>
ALARMACKNOWLEDGMENTS	<input checked="" type="checkbox"/>	<input checked="" type="checkbox"/>

Figure 97: Adding Contact Details

8.6 Adding or Editing Users (cont.)

For alarm communications, you can enter up to five email IDs and telephone numbers in the text boxes, as well as an access code and an acknowledgement code.

Clicking on the plus icon (green) enables you to enter a new email ID or telephone number, and clicking on the minus icon (red) deletes the respective email ID or telephone number.

Click **New** to create a new user, **Save** to save the changes and close the window, or close the window without saving any changes.

To delete a user, a **Close** button appears at the top right corner of the user image if you mouse over a user in the list displayed on the left. Click the **Close** button to delete the user.

If you have selected a disabled user in the Users list, then only the **Disable User** checkbox and the **Comments** textbox are editable; the other controls are disabled. To enable the controls, uncheck the **Disable User** checkbox, enter comments in the **Comments** box and click **Save**. When the user is enabled, the password of the user is also reset to the default password.

IMPORTANT: *Whenever new users are created, they are assigned default passwords that are the same as their User IDs. A user must change the default password at first log in.*

8.7 Establishing User Account Settings

The **User Account Settings** window (available under User Account Management) allows you to adjust basic account parameters applicable to all users.

The screenshot shows the 'USER ACCOUNT SETTINGS' dialog box. It features a blue header with the GE logo and the title 'USER ACCOUNT SETTINGS'. The settings are as follows:

- MINIMUM PASSWORD LENGTH:** A numeric input field containing '6'.
- DISABLE ACCOUNT AFTER FAILED ATTEMPTS:** A numeric input field containing '4'.
- REQUIRE STRONG PASSWORD:** An unchecked checkbox.
- PASSWORD RESET AFTER:** A numeric input field containing '30' followed by the text 'DAYS'.
- SCHEDULE ALLOWED:** A numeric input field containing '2' followed by the text 'PER USER'.

At the bottom of the dialog are three buttons: 'RESET', 'OK', and 'CANCEL'.

Figure 98: User Account Settings

- You can disable an account after it has been unused for a specified number of days. In the **Disable Account After** box, scroll to (or type in) the desired number of days, from 1 up to 366.
- You can also specify the minimum length of the password, from 6 to 16 characters. In the **Minimum Password** box, scroll to (or type in) the desired number of password characters; the default number is 6.
- You can **Disable Accounts** after a specified number of unsuccessful login attempts. (The default number is 3.) This option will disable a user account if there are three consecutive PC login failures for the same user User ID. If a user's account is disabled, the System Administrator must enable the account and assign a new temporary password. Enter the number of Failed Attempts, after which the account will be disabled.

8.7 Establishing User Account Settings (cont.)

- If needed, you can also require a **Strong Password** by clicking the associated checkbox. For a strong password, please enter a valid password with first letter as upper case, at least one lower case letter, one digit and one special character.

Note: *Valid special characters for a strong password are: @#\$\$%^&+=*

- You can require a **Password Reset** -- that is, replace the password with a different one -- after a specified number of days. Enter the desired number of days in the text box. The password will be reset to the default one and user will need to change the default password at first log in.
- Each user account can be associated with a specified number of **Schedules**. (The default is 2.) Enter the number in the text box.

When you have finished entering settings:

- Click **Reset** to return the settings to default,
- **OK** to save the changes and close the window,
- or **Cancel** to close the window without saving any changes.

8.8 Scheduling User Vacations

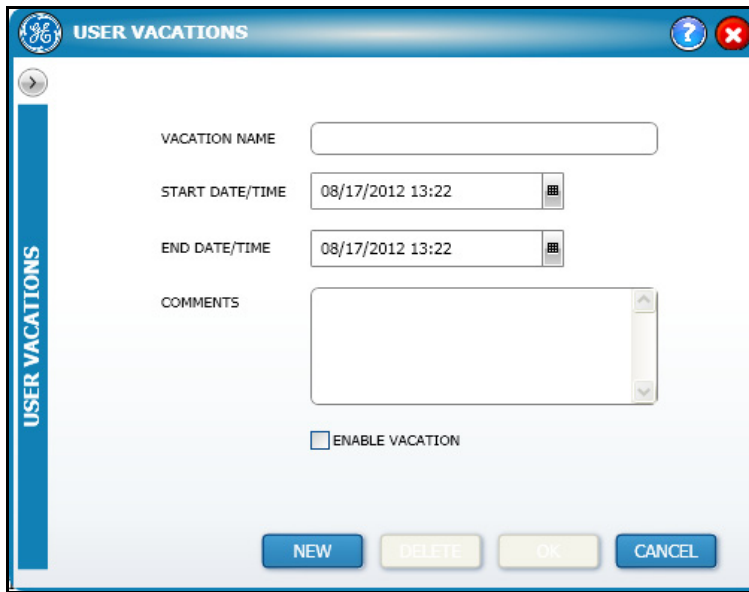

Figure 99: User Vacations

The User Vacations window enables each user to enter dates and times of user vacations into the database, so that LabWatch LT will not send messages to those particular contacts during their vacation periods.

1. Enter the **Vacation Name** in the associated text box.
2. From the drop-down calendars, click on the vacation **Start Time** and **End Time**.
3. In the text box, enter any appropriate **Comments**.
4. Click the **Enable Vacation** checkbox to enter the vacation into the database.

When you have finished, click **New** to enter another vacation, **Delete** to delete an existing vacation, **Cancel** to close the window without saving data, or **OK** to save the vacation and close the window.

8.9 Maintaining Calibration Records

When you click on **Calibration** under the User Calibration heading on the Configuration screen, the User Calibration window is launched.

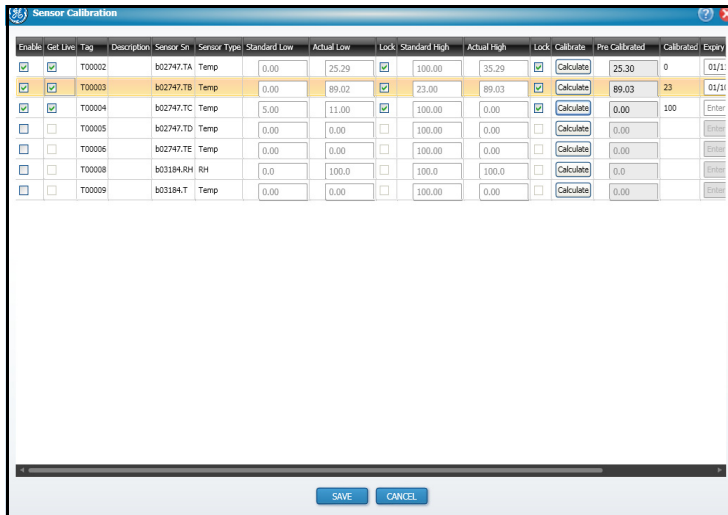

Enable	Get Live	Tag	Description	Sensor Sn	Sensor Type	Standard Low	Actual Low	Lock	Standard High	Actual High	Lock	Calibrate	Pre Calibrated	Calibrated	Expiry
<input checked="" type="checkbox"/>	<input checked="" type="checkbox"/>	T00002	b02747.TA	Temp		0.00	25.29	<input checked="" type="checkbox"/>	100.00	25.29	<input checked="" type="checkbox"/>	Calculate	25.30	0	01/11
<input checked="" type="checkbox"/>	<input checked="" type="checkbox"/>	T00003	b02747.TB	Temp		0.00	89.02	<input checked="" type="checkbox"/>	23.00	89.03	<input checked="" type="checkbox"/>	Calculate	89.03	23	01/11
<input checked="" type="checkbox"/>	<input checked="" type="checkbox"/>	T00004	b02747.TC	Temp		5.00	11.00	<input checked="" type="checkbox"/>	100.00	0.00	<input checked="" type="checkbox"/>	Calculate	0.00	100	Enter
<input type="checkbox"/>	<input type="checkbox"/>	T00005	b02747.TD	Temp		0.00	0.00	<input type="checkbox"/>	100.00	0.00	<input type="checkbox"/>	Calculate	0.00		Enter
<input type="checkbox"/>	<input type="checkbox"/>	T00006	b02747.TE	Temp		0.00	0.00	<input type="checkbox"/>	100.00	0.00	<input type="checkbox"/>	Calculate	0.00		Enter
<input type="checkbox"/>	<input type="checkbox"/>	T00008	b03184.RH	RH		0.0	100.0	<input type="checkbox"/>	100.0	100.0	<input type="checkbox"/>	Calculate	0.0		Enter
<input type="checkbox"/>	<input type="checkbox"/>	T00009	b03184.T	Temp		0.00	0.00	<input type="checkbox"/>	100.00	0.00	<input type="checkbox"/>	Calculate	0.00		Enter

Figure 100: User Calibration Window

This window allows users to calibrate the sensors. It also keeps record of the calibration status and data of the various tags. Columns include:

- **Calibrate** — Click the checkbox to enable calibration of a tag, or clear it to disable calibration.
- **Tag** — displays the tag name.
- **Description** — provides the tag description.
- **Type** — valid values are Temp and RH. The sensor calibration screen displays the temperature and RH sensors, but not AI/DI sensors.
- **Standard Low** — value entered by user.

8.9 Maintaining Calibration Records (cont.)

- **Actual Low** — latest tag value, which fluctuates according to the values being read. (This field is not editable by the user.)
- **Lock** – Clicking this checkbox will freeze the value of “Actual Low”, i.e., the value will not change.
- **Standard High** — value entered by user.
- **Actual High** — latest tag value, which fluctuates according to the values being read. (This field is not editable by the user)
- **Lock** — Clicking this checkbox will freeze value of “Actual High” i.e., value will not change.
- **Pre Calibrate Value** — the tag value before calibration.
- **Calibrated Value** — tag value after calibration, displayed after both “Lock” boxes are checked by the user.
- **Expiration Date** — date on which user calibration will expire. Tag rows will appear in red upon the expiry of calibration date.
- **User Calibration Date** — date on which user calibration was performed.

When you have finished, click **Save** to save the changes, or **Cancel** to exit the window without saving the changes.

8.10 Configuring Tags and Groups

8.10.1 Entering the Tag Configurator

When you click on the **Tag/Group Config** option under Tag Configuration, the Tag Configurator window is launched.

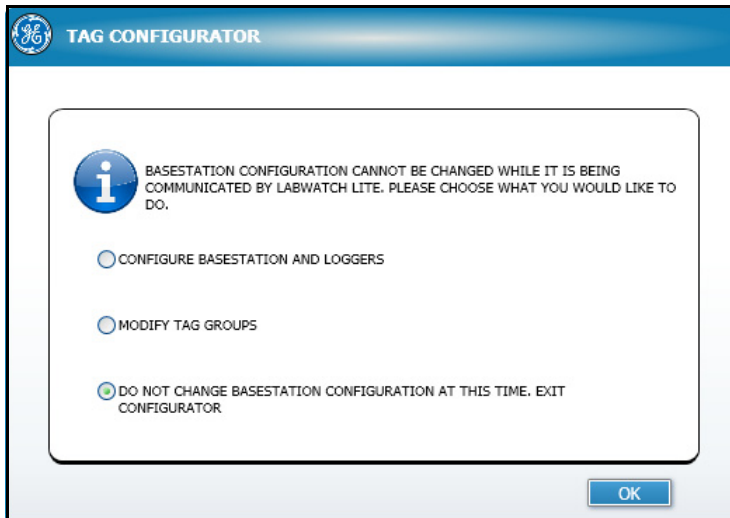

Figure 101: Tag Configurator Window

You have three options:

- To reconfigure Base Stations and Loggers, the communication between a Base Station and LabWatch LT will be stopped. Tag Configurator GUI will be launched. LabWatch LT will not record data until you exit the Tag Configurator.
- You can **Modify Tag Groups**. If you select this option, you will enter the Assign Tags tab of the Configurator, but will not be able to access the Configure Base Stations tab. In this option, LabWatch LT will continue to record data.
- You can exit the Configurator without making any changes.

Click on the desired option button and click **OK**.

8.10.2 Locating Base Stations and Loggers

If you have clicked on the **Configure Base Stations and Loggers** option button, the **Configure Base Stations** tab (Figure 102 below) of the Configurator opens. Click on **Discover Base Stations** to determine what Base Stations are on your network, and click on **Get Loggers** to find the Loggers for each of the selected Base Stations. You can also **Enter an IP Address** to locate a particular Base Station.

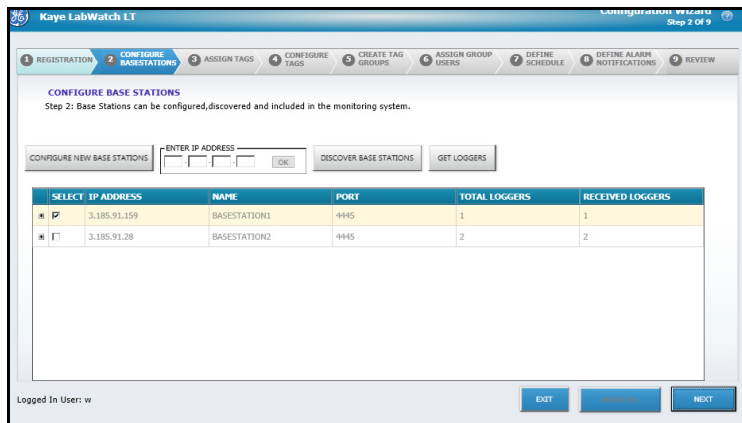

Figure 102: Configure Base Station Window

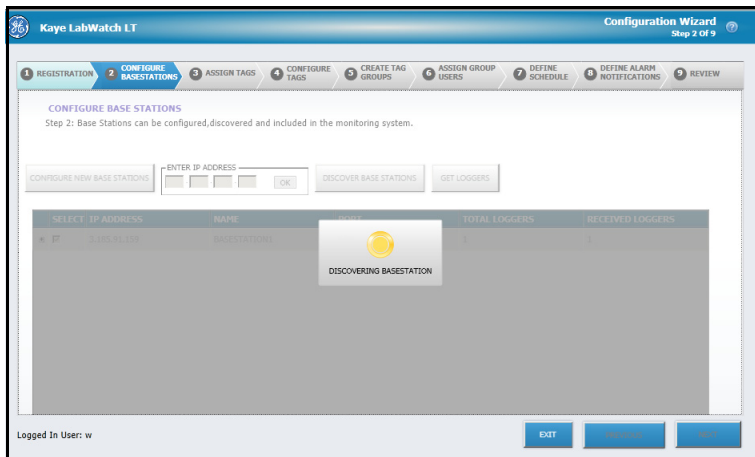

Figure 103: Discovering Base Stations

8.10.2 Locating Base Stations and Loggers (cont.)

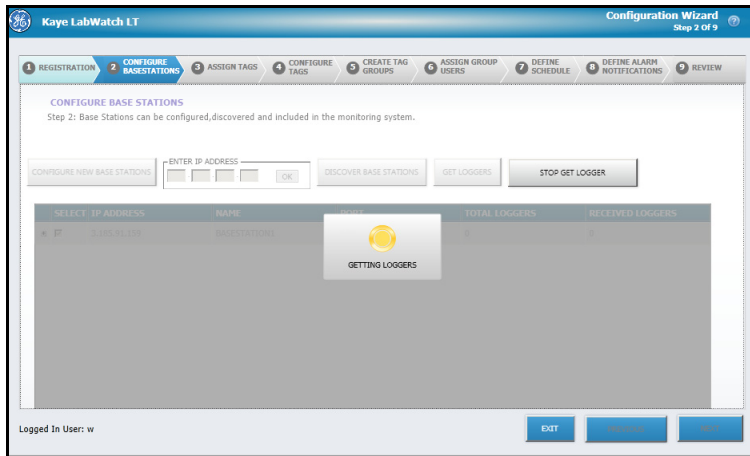

Figure 104: Getting Loggers

When a user clicks on **Get Loggers**, it toggles to a **Stop Get Loggers** button. Clicking on **Stop Get Loggers** will stop LabWatch LT from searching for Loggers from selected Base Stations.

After the Loggers have been received and displayed, a user can select/unselect Base Stations and Loggers by clicking the corresponding check boxes. Click **Next** when you have finished.

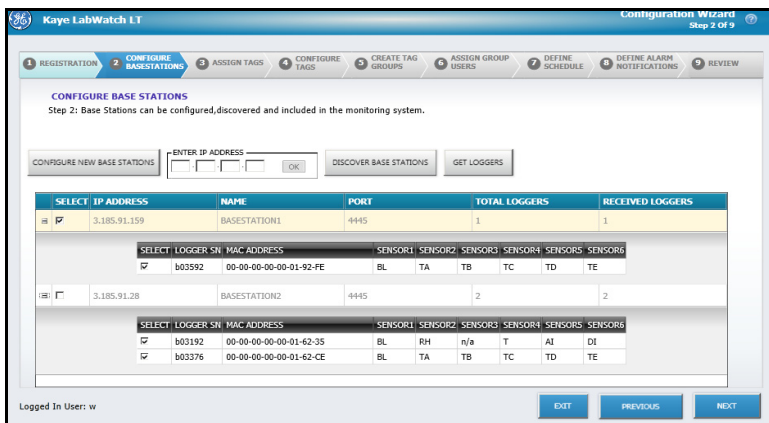

Figure 105: Screen Populated with Base Stations

8.10.3 Modifying Tag Groups

Note: If you selected **Modify Tag Groups** in the Tag Configurator, you will enter the Configurator at this point.

When you have populated the list, you will proceed to the Assign Tags tab (Figure 107 below). In the Enabled column, clear the checkbox for any tag you do not want to enable. In the Tag and Tag Description columns, you can enter your own tag IDs and descriptions. To create automatic tags, click the **Generate Tag** button. If you need to reassign a tag, click the **REASSIGN Tag** button. By default, “Group By” will list all the base stations. Selecting a particular base station will list sensors related to that selected base station.

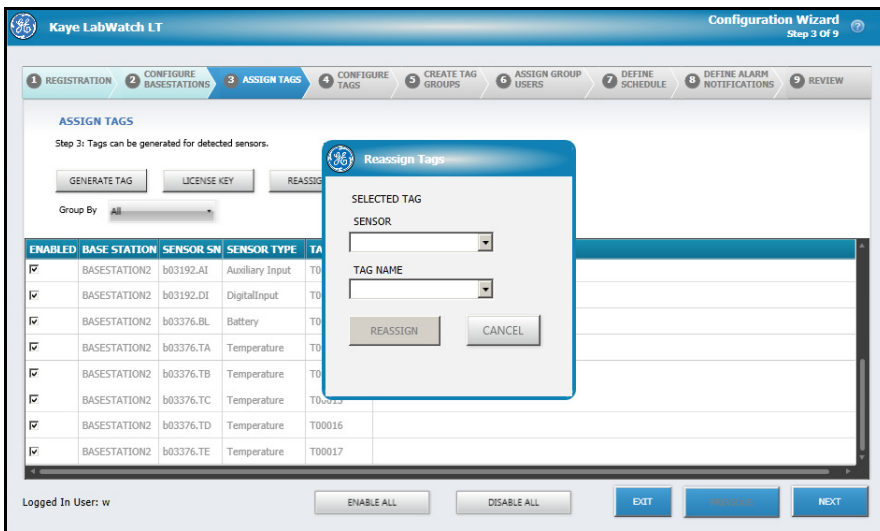

Figure 107: Assign Tags Tab

- Clicking **ENABLE ALL** will enable all sensors.
- Clicking **DISABLE ALL** will disable all sensors.

8.10.3 Modifying Tag Groups (cont.)

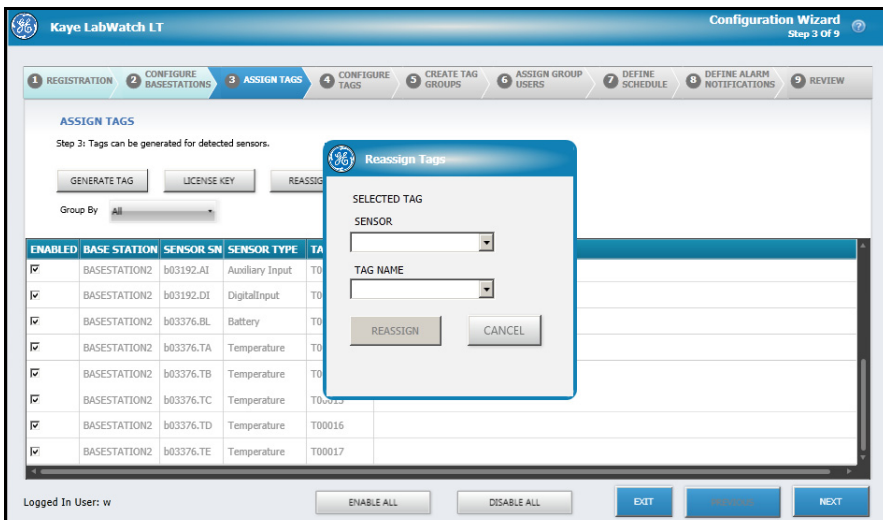

Figure 108: Reassigning Tags

When you have completed sensor and tag association, click **Next** if you need to enter more data, or click the **Review** tab and click **Finish** to close the Tag Configurator and return to LabWatch LT.

8.11 Establishing Basic Display Parameters

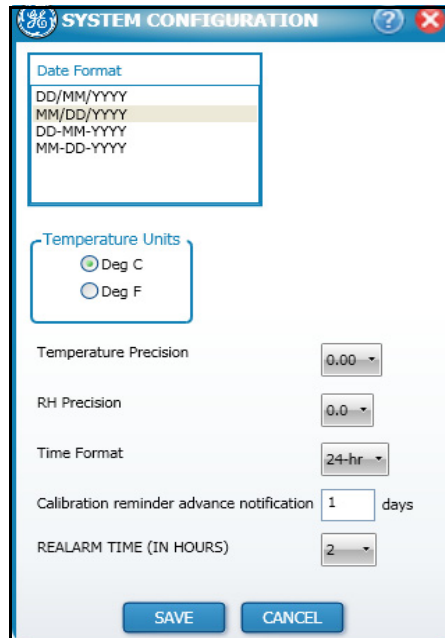

Figure 109: System Configuration Window

The System Configuration window allows you to set up basic display parameters: Date and Time format, temperature units, measurement precision, etc.

- From the boxed list, select the desired **Date Format**: Day-Month-Year or Month-Day-Year, separated either by hyphens or slashes.
- Click on the option button to select the **Temperature Units**: either Celsius or Fahrenheit.
- From the drop-down list, click on the desired level of **Temperature Precision**. You can choose from whole integers, one decimal place or two decimal places.
- Repeat this selection for **RH Precision**. The choice is between whole integers and one decimal place.
- Select 12 hour or 24-hour **Time Format**.

8.11 Establishing Basic Display Parameters (cont.)

- In the **Calibration reminder advance notification**, enter the number of days during which the system reminds you about the calibration due date for a particular tag before expiration of calibration is due date.
- **REALARM TIME** will determine the time to re-alarm if there is no change in the alarm state after acknowledgement until re-alarm time is elapsed. The Valid times for re-alarm are 1 hour, 2 hours, 4 hours, and 24 hours. The default is 2 hours.

When you have finished, click **Save** to save the entries and close the window, or **Cancel** to exit the window without saving any entries.

8.12 Locking and Unlocking Kaye LabWatch LT

To lock or unlock LabWatch LT, click on **Lock** in the System section.

8.12.1 Locking the System

Only Administrator users have permission to lock the system. A locked system will not let users perform the following operations:

- They cannot launch Task Manager.
- They cannot see the Windows Start icon and task bar.
- They cannot access the system by any kind of Windows key combination (Alt + Tab, etc.)

Note: *Clicking **LOCK** will toggle the caption to **UNLOCK**.*

8.12.2 Unlocking the System

Only Administrator users can unlock the system. Clicking **UNLOCK** toggles the caption to **LOCK**, and now users can access the system through any Windows key combination.

IMPORTANT: *LabWatch LT cannot be shut down as long as the system is locked.*

8.13 Sensor Calibration Reminder Screen

The Sensor Calibration Reminder screen indicates that the calibration has reached the expiration date.

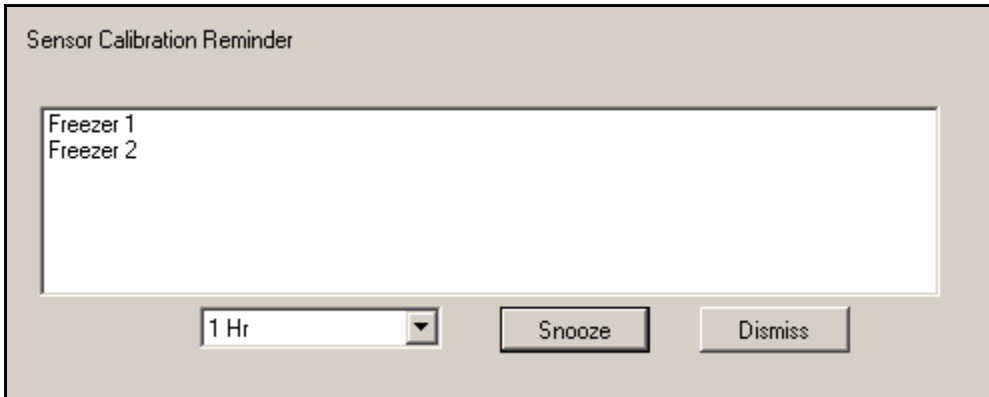

Figure 110: Calibration Reminder Screen

It appears whenever the number of reminder days before the expiration date is set. On the screen you can click either **Snooze** or **Dismiss**.

- **Snooze** will pop up according to the time you set.
- **Dismiss** will dismiss the operation.

If the user clicks on **Snooze**, LabWatch LT requests login information; after the user has logged in, it will store the revised snooze information. If the user clicks on **Dismiss**, LabWatch LT requests login information and then stores the dismissal information to the database.

You can set the number of reminder days in the System Configuration option.

8.14 Back Up and Restore Database



Figure 111: Backup and Restore Database

This screen allows users to back up and restore the database.

- When you click **Back Up**, the program backs up the LabWatch LT database to a specific path that has been selected through the **Browse** button.
- When you click **Restore**, the program will restore the database on the path selected through the **Browse** button.

8.15 Monitoring RF Signal Strength

RF strength depicts the strength of the wireless connection between a Base Station and logger and also between loggers. To view and graph the various RF strengths of signal paths, click **LabWatch LT RF Signal Strength Graph**, a separate utility available from the **Start** menu. The **Logger Network Strength Graph** screen opens. From the File menu, click on **Connect**.



Figure 112: Logger Network Strength Graph

The **Connect to Base Station** window opens. Click **Discover Base Stations** to find a list of Base Stations available on the network.

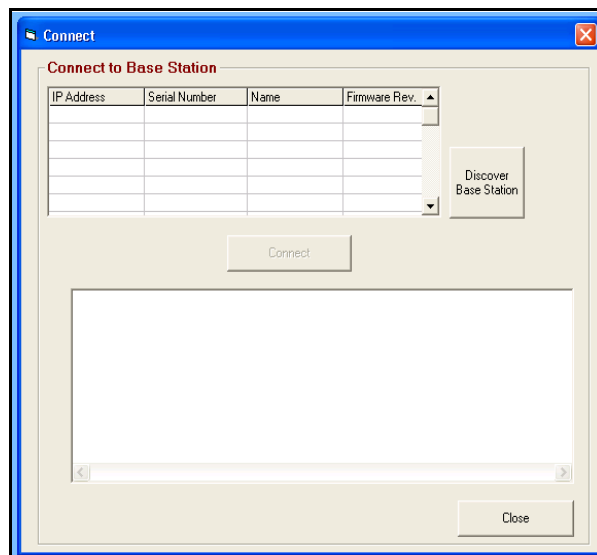

Figure 113: Connect to Base Station Window

8.15 Monitoring RF Signal Strength (cont.)

When the list of Base Stations in the upper pane is populated, highlight the Base Station you need and click **Connect**.

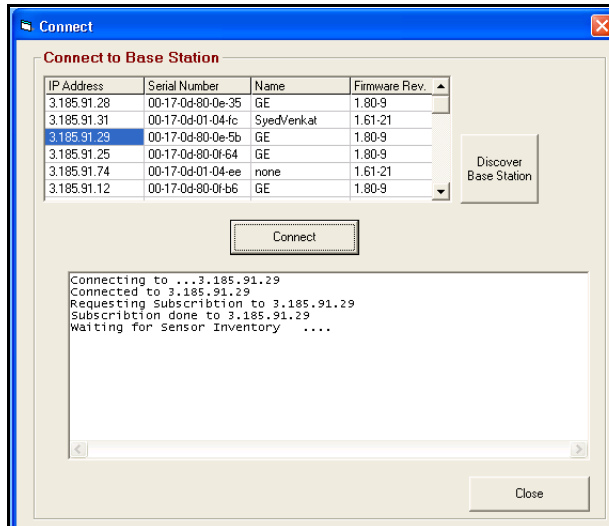

Figure 114: Connecting a Base Station

The main Logger Network Strength Graph window reopens. After up to 15 minutes, the graph of Base Stations, Loggers and signal strength paths appears.

8.15 Monitoring RF Signal Strength (cont.)

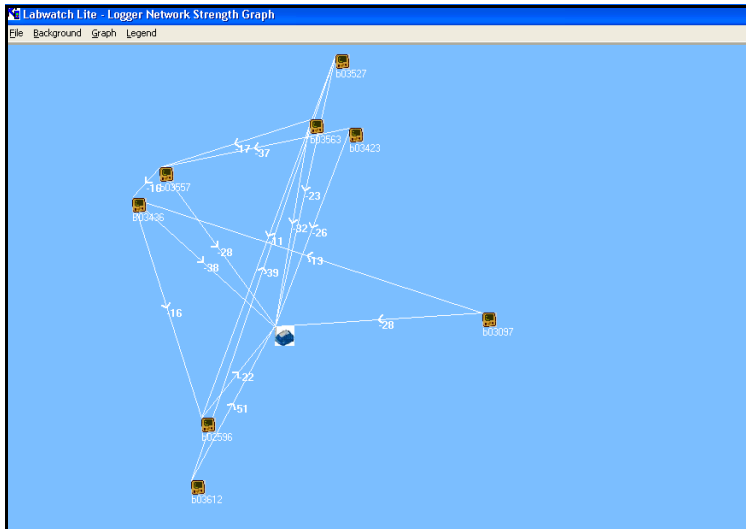

Figure 115: Signal Strength Graph

The **Legend** option in the Main Menu enables users to interpret the graph. It shows the color codes for signal strength, and the symbols for Base Stations and Loggers. Connection strength > -60 is considered good; $-70 <$ and < -60 as OK; and < -70 is Bad.

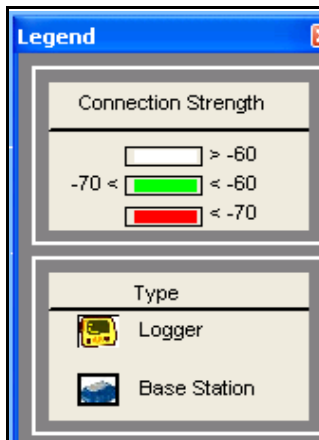

Figure 116: Legend Window

8.15 Monitoring RF Signal Strength (cont.)

In the **Background** option, you can add (or clear) a background diagram or photo on which the software will superimpose the signal path graph. You can also show the signal strength as a number, and display the Logger by ID or by serial number.

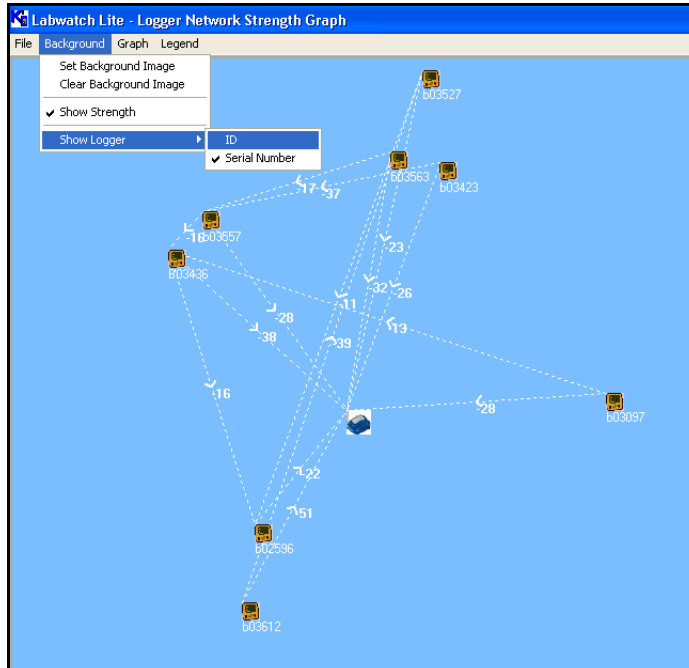

Figure 117: The Background Option Menu

8.15 Monitoring RF Signal Strength (cont.)

The **Graph** option allows you to reconfigure the colors and line appearance of the graph. You can click on a color to open palettes of color for the Background, Signal Strengths, Direction, Logger ID/SN and Strength. You can also select the signal path line format from three dashed line selections.

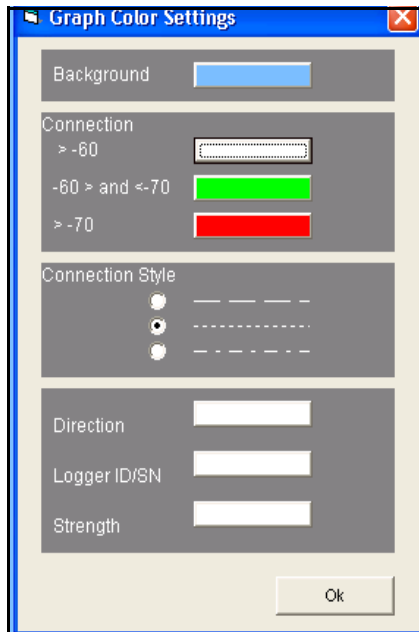

Figure 118: Graph Color Settings

Finally, you can return to the **File** menu to **Print** the graph on a selected printer, or to **Exit** the Logger Network Strength Graph.

Appendix A. Configuring Telephone Notifications

This appendix defines the steps needed for installation of the LabWatch LT Telephony Notification for alarms. It focuses on:

1. Dialogic Diva Analog 2p Hardware installation
2. Configuring and testing the Diva board
3. Configuring and using LabWatch telephone service

A.1 Prerequisites

- LabWatch LT, installed and configured
- Dialogic Diva Analog 2p PCIe Board
- Dialogic Diva 64 bit (for 64 bit OS), 32 bit (for 32 bit OS) drivers.
- OS: Windows XP or Windows 7 (32 bit or 64 bit)
- System with PCIe (1x or greater) slot.

A.2 Installing Diva Analog 2p Board

This section will assist you in installing your Dialogic® Diva® Media Board and connecting it to an analog line.

You need to complete the following three procedures to use your Diva Media Board properly:

1. Insert your Diva Media Board into your computer as described below.
2. Connect your Diva Media Board.
3. Install your Dialogic® Diva® System Release.

Note: *You may need to consult your computer's manual during the installation of your Diva Media Board.*

A.2.1 Inserting Your Diva Media Board into Your Computer

1. For your safety, disconnect all technical and peripheral devices and all energy sources from the computer.
2. Drain static electricity from your body by touching the metal chassis (the unpainted metal at the back of your computer).
3. Remove the cover of the computer as described in your computer's manual.
4. Locate the PCIe slot in your computer.
5. If there is a metal plate at the end of the slot, remove the screw or loosen the clip and remove the metal plate. Keep the screw for fastening your Diva Media Board.
6. If your Diva Media Board comes with a retainer, and space does not permit the use of the retainer, simply remove it before you insert the Diva Media Board. The retainer is only an installation aid, and does not add functionality to the board.

A.2.1 Inserting Your Diva Media Board into Your Computer (cont.)

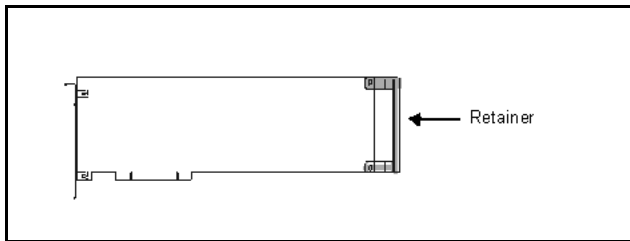

Figure 85: Retainer on PCI Board

7. Before you insert your Diva Media Board, read the following safety instruction:

CAUTION! To avoid damaging your hardware, insert the Diva Media Board only into a PCI or PCIe slot, according to your board type. Inserting the Diva Media Board into any other type of slot can damage your board, your computer, or both.

8. Firmly insert the Diva Media Board into the selected slot. Make sure that the Diva board does not touch the CPU, memory modules, or other parts on the motherboard.

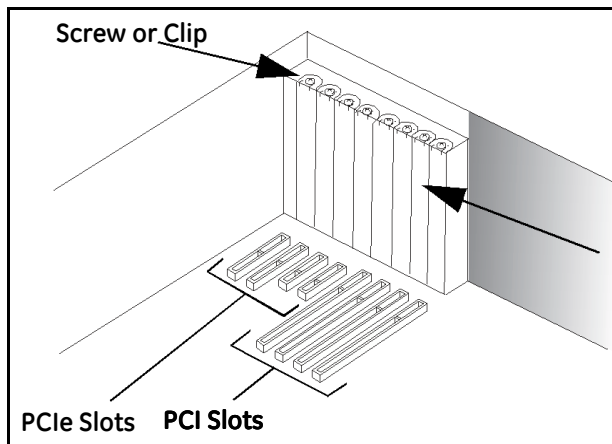

Figure 86: PCI Slots with Screw or Clip

9. Firmly secure the Diva Media Board with the screw or clip.

A.2.1 Inserting Your Diva Media Board into Your Computer (cont.)

WARNING! For your safety, make sure that the Diva Media Board's bracket is properly secured to the PC's chassis by fastening the Diva Media Board with the screw or clip. This will ensure proper grounding and avoid personal injuries and damage to your computer, your Diva board, or both.

10. Replace the cover of the computer as described in your computer's manual.

A.2.2 Connecting Your Dialogic® Diva® Analog Media Board

Use the cables included with the Diva Analog Media Board.

A.2.2a Dialogic® Diva® Analog-2 Media Boards

Diva Analog-2 Media Boards have two RJ10 ports for connecting two separate analog lines. You can use any port; typically, you must specify the port number during software configuration. The port numbers are shown in Figure 87 below. The diagram is oriented with the edge connector pointing downwards.

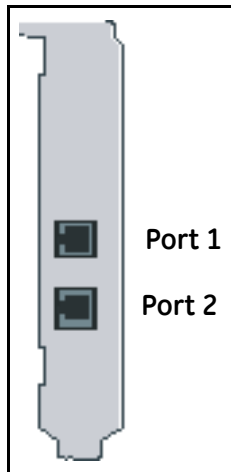

Figure 87: RJ10 Ports

A.2.2 Connecting Your Dialogic® Diva® Analog Media Board (cont.)

Connect your Dialogic® Diva® Analog-2 Media Board as follows:

1. Take the two cables included with the Diva Media Board and plug the RJ10 connectors into the board.

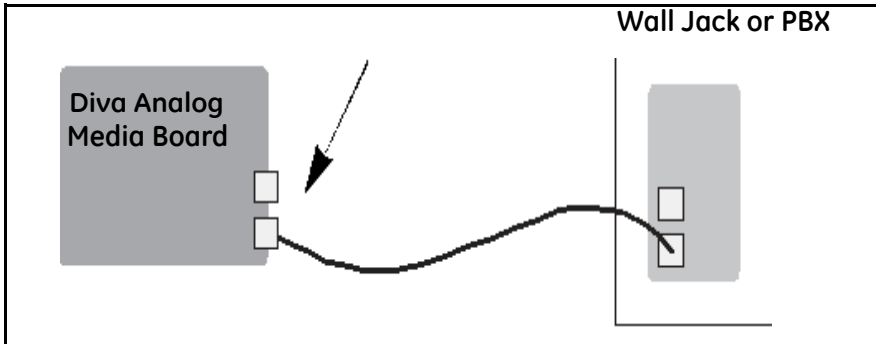

Figure 88: Connecting Media Board

2. Plug the RJ11 connectors into the wall jack or PBX.

Table 1: Contact Assignments (Plugs and Jacks)

RJ10	Signals	RJ11
Pin 2	Ring	Pin 3
Pin 3	Tip	Pin 4

Note: Looking at the RJ10 and RJ11 connector with the exposed connector pins facing you, the pins are numbered from 1 to 4 and 1 to 6 from left to right as shown below.

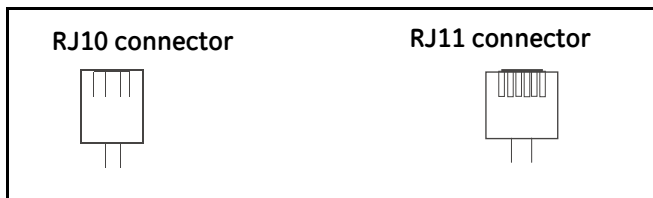

Figure 89: RJ10 and RJ11 Connectors

A.3 Configuring the Diva Board

To configure the Diva board (for caller ID), run Configuration Manager from: **Start->All Programs->Dialogic Diva**

1. Select the lines.

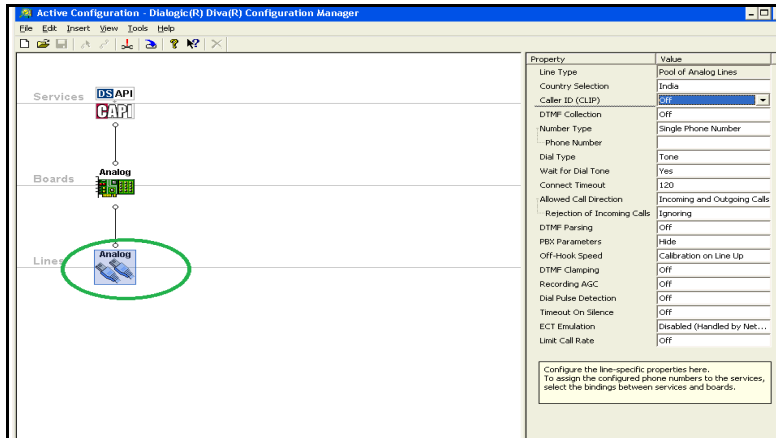

Figure 90: Line Selection

2. Set Caller ID option as **On**.

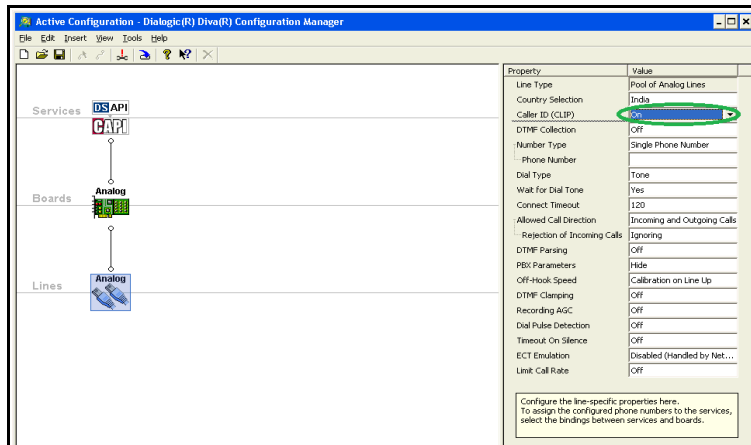

Figure 91: Caller ID Options

A.4 Testing Diva Board

To test the Diva board, run **Line Test** utility from: **Start->All Programs->Dialogic Diva**.

1. (Line connection check) Select the device and click on **Start** to check\test the line.

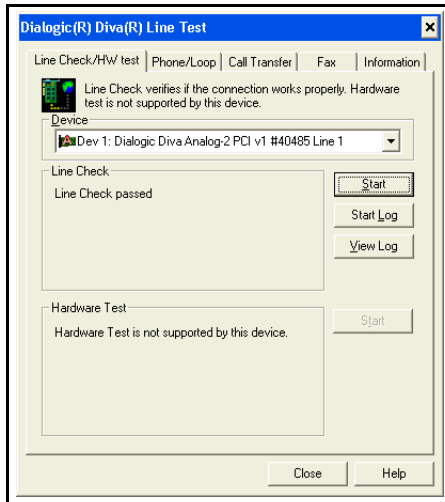

Figure 92: Line Check Tab for Diva Test

If everything is configured properly, the test result will be **Line Check Passed**.

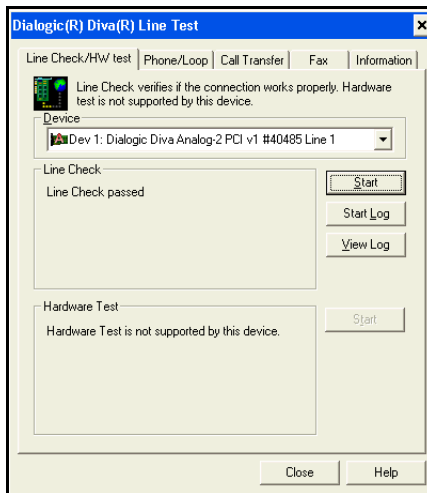

Figure 93: Line Check Passed

A.4 Testing Diva Board (cont.)

- (Out Call Test) Type the number in the **Called Party Number** field (along with Prefix and Suffix code if needed).

Click on the **Call** button. It will show the call progress in the Status box. If the call is connected, it will play a default system prompt.

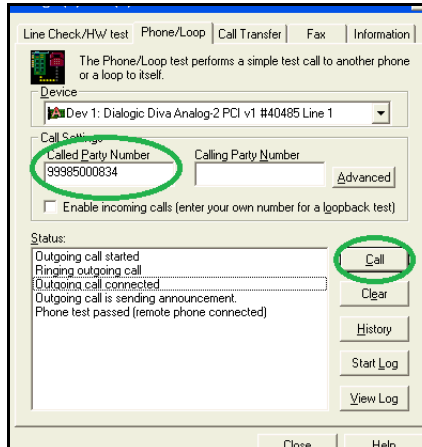

Figure 94: Testing Outbound Calls

- (Incoming Call Test) Select the **Enable incoming calls** option.

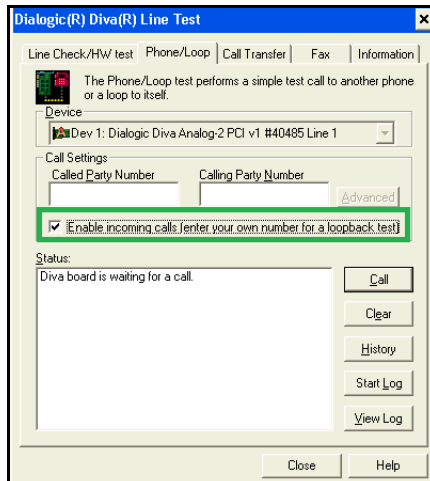

Figure 95: Enable Incoming Calls

A.4 Testing Diva Board (cont.)

4. Then dial the number of the analog line which is physically connected to the board's port. It will show the following text after receiving the call and will play a default prompt.

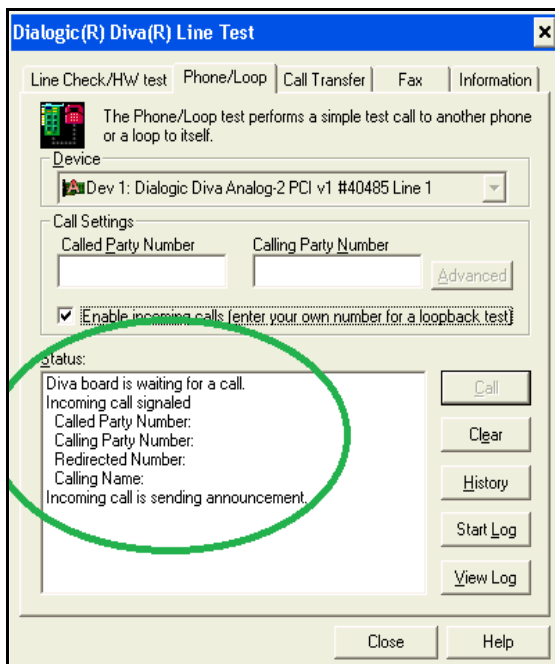

Figure 96: Text After Receiving Call

A.5 Configuring Telephone Settings

Please follow the steps below for configuring telephone settings

1. Open the LabWatch LT application.
2. Click on the **Configurations** tab and then on the **Telephony Configuration** option.

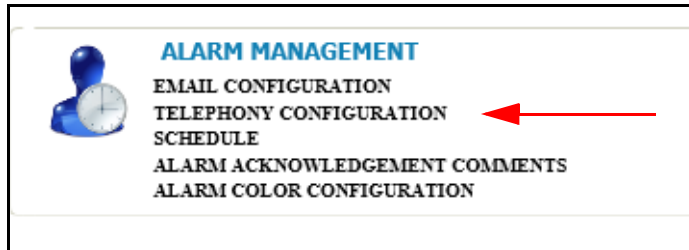

Figure 97: Telephony Configuration Option

3. On the **Voice** tab, the **Analog Dialogic Diva Card** button is selected by default.

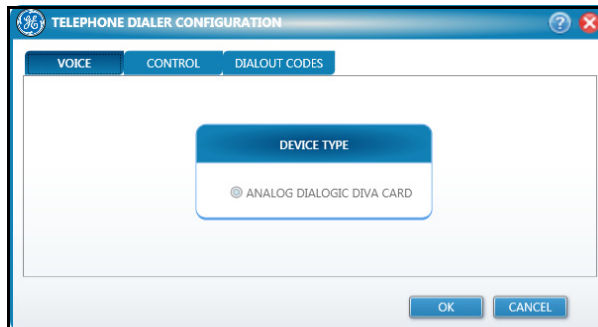

Figure 98: Analog Dialogic Diva Card Option Button

4. Click on the **Dialout Codes** tab. Set the **Prefix** and **Suffix Code**, if needed for making a call.
 - **Prefix code** is the code needed to dial to access an outside line before dialing an actual number.
 - **Suffix code** is the code that can be needed after keying the actual number to make a call.

A.5 Configuring Telephone Settings (cont.)

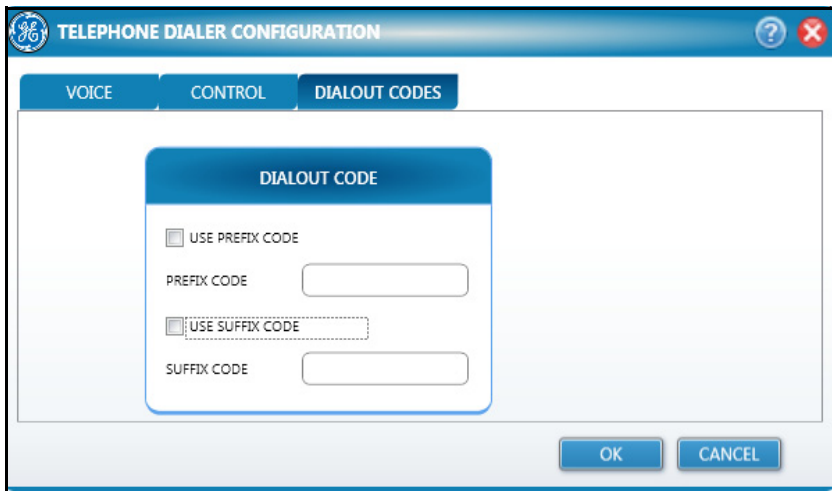

Figure 99: Prefix and Suffix Codes

A.6 Configuring a User Account for Receiving Alarms

Follow the steps below to configure a user account to receive telephone notifications.

1. Open the LabWatch LT application.
2. Click on the **Configurations** tab and then on the **Tag/Group Config** option. The Tag Configurator window (Figure 100 below) opens.

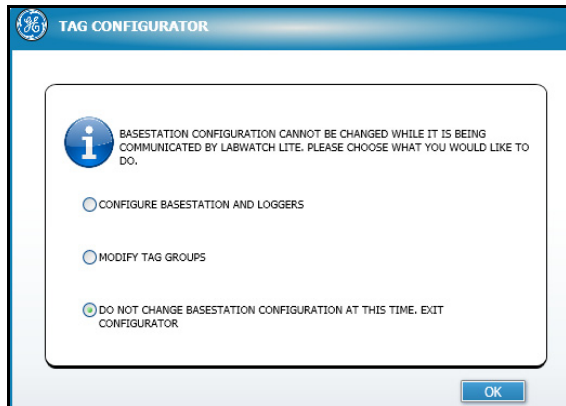

Figure 100: Tag Configurator Window

3. Select **Modify Tag Groups** and click **OK**.

A.6 Configuring a User Account for Receiving Alarms (cont.)

- The **Assign Tags** tab opens. Click on the **Create Tag Groups** tab. Then create a new group and assign the tags from the **Available Tags** list.

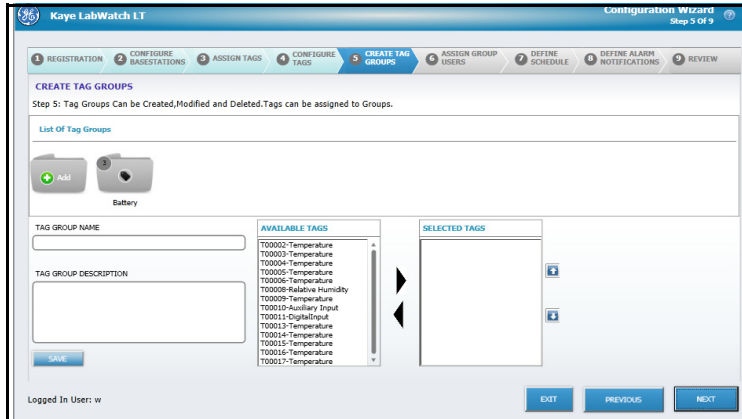

Figure 101: Creating a New Group with User

- Click **Next** to enter the **Assign Users** tab. Then select the user for the group.

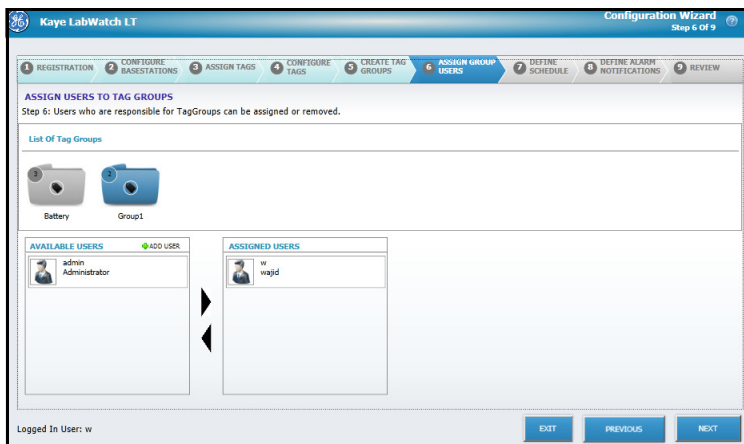

Figure 102: Assign Users Tab

- Click **Next** to proceed to the **Define Schedules** tab. Create the Schedule as needed that will be assigned to the user in the next step.

A.6 Configuring a User Account for Receiving Alarms (cont.)

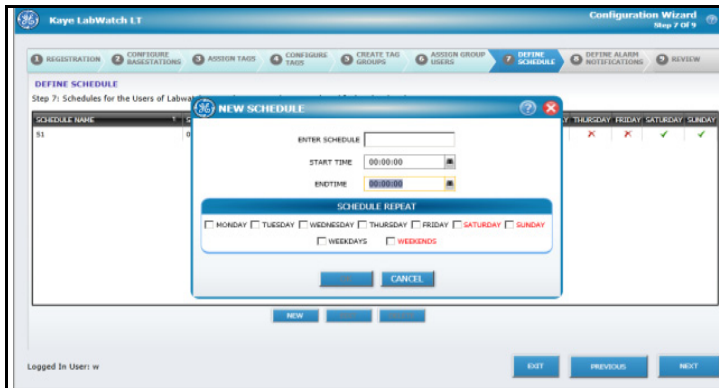

Figure 103: Define Schedules Tab

7. Click **Next** to enter the **Define Alarm Notifications** tab.
 - a. Select **Group**.
 - b. Select **Group User**.
 - c. Select **Schedule** for the User.
 - d. Select the notification type as needed.

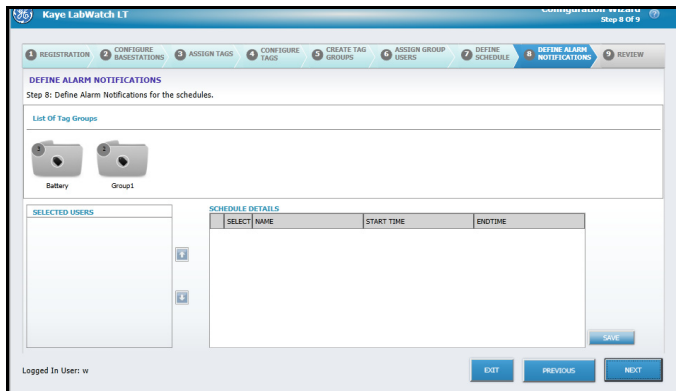

Figure 104: Define Alarm Notifications

8. Click **Next** to enter the Review tab and click **Finish** to close the Tag Configurator and return to LabWatch LT.

A.7 Telephone Alarm Notification Process

A.7.1 Steps in a Call

1. A user receives the call, but must enter the 4-digit access code.
2. The user enters the access code; if the access code is not valid, the telephone system tries three (3) times and then disconnects.
3. If the access code is valid, the message covers alarms for Tags for which the user is responsible. A user can request message replay.
4. The system asks for an acknowledgement code.
5. If the acknowledgement code is invalid, the call is disconnected. If the acknowledgement code is correct, the user acknowledges all alarms, and confirms.
6. The call ends.

A.7.2 The Telephone Notification Process

- Users assigned to a group will have priority and will be notified based on their priority.
- Users will also have schedule defined and, within that schedule, only the user will be notified.
- If user1 is unable to take the call, the system will try three times.
- If the system cannot connect after 3 retries, the call will go to next user in priority list.
- This cycle will repeat until any one of the users acknowledges the alarms.
- Each user will have only one number.
- If any user of the group acknowledges the call, the system will stop calling, and the next user in the priority list will not receive a call.

[no content intended for this page - proceed to next page]

Appendix B. Configuring Email Notifications

This appendix defines the steps needed to configure the LabWatch Email Service. Topics covered include:

- Configuring Email Settings
- Configuring User account for receiving Alarm

B.1 Requirements

- LabWatch LT is installed and configured.
- Email account with IMAP and SMTP support.
- Required IMAP and SMTP port should not be blocked.
- Required IMAP and SMTP server should not be blocked.

B.2 Configuring Email Settings

To configure your email settings, follow the steps below:

1. Click the **Configuration** tab and click the **Email Configuration** option.

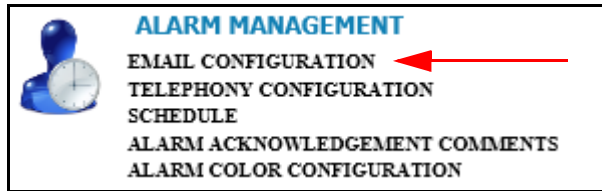

Figure 105: Email Configuration Option

2. On the Email Server tab, set Outgoing and Incoming mail server details for the Mail server.

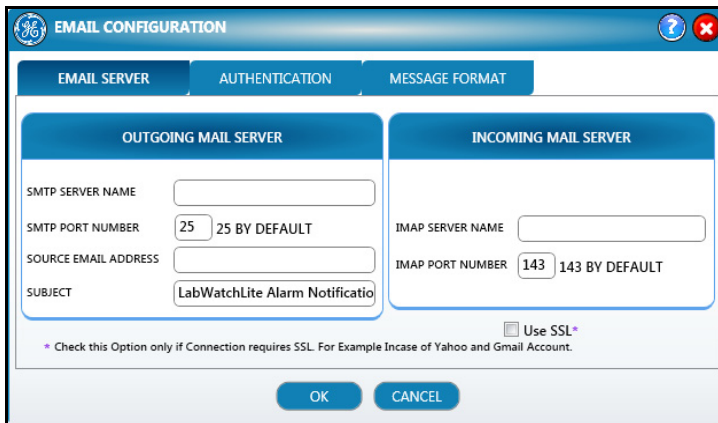
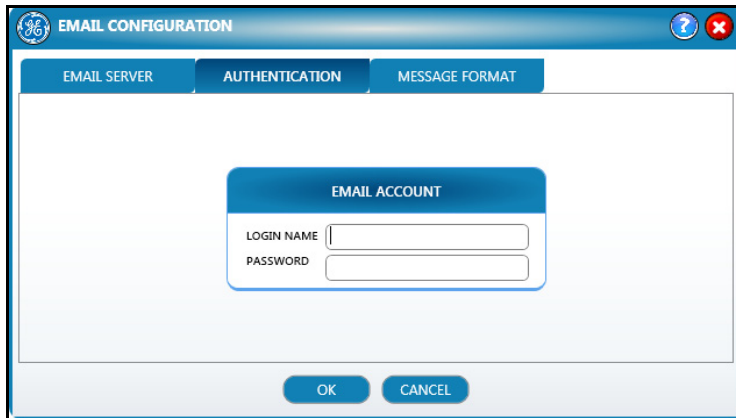

Figure 106: Email Server Tab

B.2 Configuring Email Settings (cont.)

3. Select the **Authentication** tab and provide the email account credentials.



The screenshot shows a dialog box titled "EMAIL CONFIGURATION" with three tabs: "EMAIL SERVER", "AUTHENTICATION", and "MESSAGE FORMAT". The "AUTHENTICATION" tab is selected. Inside the dialog, there is a section titled "EMAIL ACCOUNT" containing two input fields: "LOGIN NAME" and "PASSWORD". At the bottom of the dialog are "OK" and "CANCEL" buttons.

Figure 107: Authentication Tab

B.3 Configuring the User Account for Receiving Alarms

Follow the steps below to configure a user account for receiving an email notification.

1. Open the LabWatch LT application.
2. Click on the **Configurations** tab and then on the **Tag/Group Config** option. The Tag Configurator window (Figure 108 below) opens.

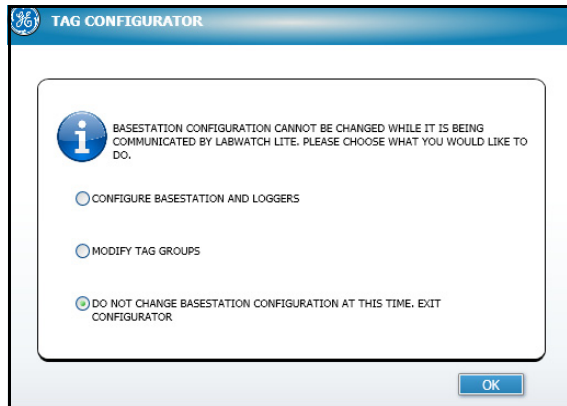

Figure 108: Tag Configurator Window

3. Select **Modify Tag Groups** and click **OK**.

B.3 Configuring a User Account for Receiving Alarms (cont.)

- The **Assign Tags** tab opens. Click on the **Create Tag Groups** tab. Then create a new group and assign the tags from the **Available Tags** list.

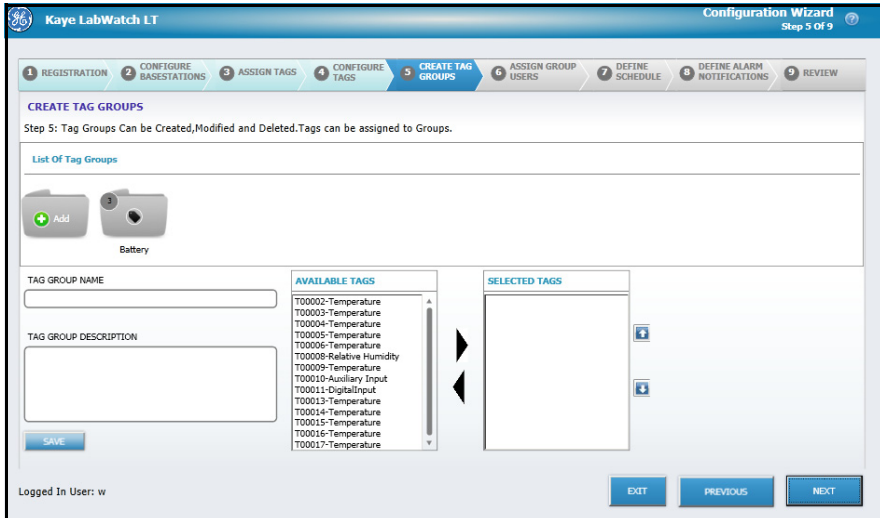

Figure 109: Creating a New Group with User

- Click **Next** to enter the **Assign Users** tab. Then select the user for the group.

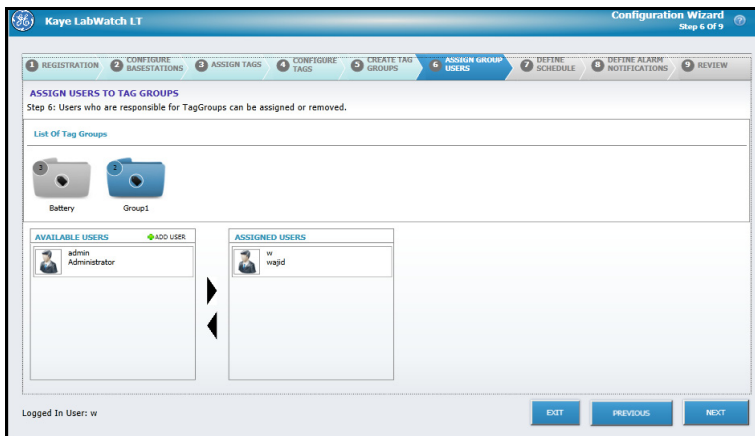

Figure 110: Assign Users Tab

B.3 Configuring a User Account for Receiving Alarms (cont.)

6. Click **Next** to proceed to the **Define Schedules** tab. Create the Schedule as needed that will be assigned to the user in the next step.

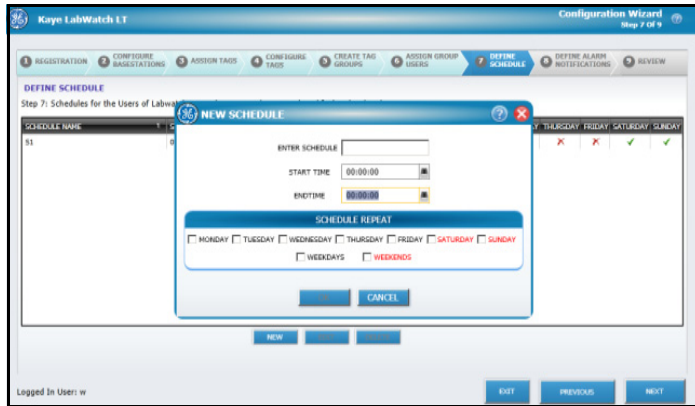

Figure 111: Define Schedules Tab

7. Click **Next** to enter the **Define Alarm Notifications** tab.
 - a. Select **Group**.
 - b. Select **Group User**.
 - c. Select **Schedule** for the User.
 - d. Select the notification type as needed.

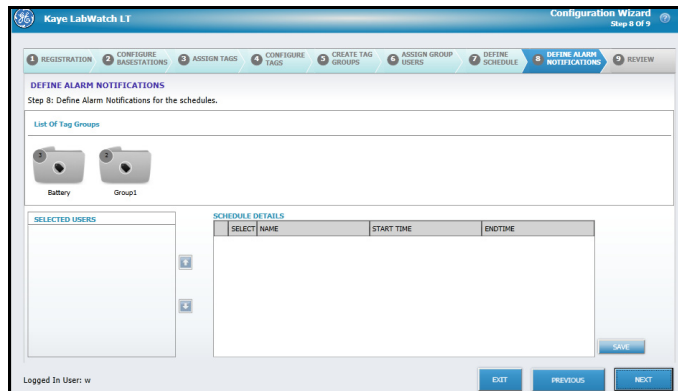

Figure 112: Define Alarm Notifications

8. Click **Next** to enter the Review tab and click **Finish** to close the Tag Configurator and return to LabWatch LT.

Appendix C. Battery Count Reset

C.1 Logger Battery Change and Battery Count Reset

Please follow the steps below to reset the battery count of a logger after batteries are changed:

1. Power off the logger and change the battery.
2. While holding the **Status** button, power on the logger.
3. While holding the **Status** button, wait 15 seconds.
4. Five (5) blinks on the Power light will confirm the battery reset.
5. Release the **Status** button.

[no content intended for this page - proceed to next page]

Appendix D. Glossary

Alarm Acknowledgement: If a user acknowledges an alarm, there are two possible changes in the system.

1. If the alarm is acknowledged, the value stabilizes to an OK state, then the alarm is cleared from the Alarm Tab. Also, the flashing of the alarm for the tag stops at the monitoring screen.
2. If the alarm is acknowledged, the value does not reach an OK state (still retains in an alarm condition), then the flashing of the alarm is stopped, but the alarm state is still retained. Usually the alarm state at Alarm tab and at the monitoring screen refreshes every minute.

Alarm Delay: Along with values, users can set a delay period for an alarm (in hours, minutes and seconds, up to 23 hours, 59 minutes and 59 seconds), before triggering an alarm on the screen

Comm Alarms: Comm alarm indicates loss of communication with a particular tag. It may be because of several reasons; for example, the RF logger is out of range and not able to communicate with the system, or there is a loose sensor in the logger.

IMPORTANT: *Open Circuit, Over Range and Under Range alarms are all reported under Comm alarms in LabWatch LT.*

Hi and HiHi Alarms: Two high alarms, HI and HIHI, create an alarm on the screen that appears in the audit trail, if a value rises above the preset value. Since they are independent limits, a user has two different thresholds for alarming. (Typically, the HIHI value is set higher than the HI value to indicate that a condition has become worse.) User can apply any one condition or combination of alarm limits.

Lo and LoLo Alarms: Two low alarms, LO and LOLO, create an alarm on the screen that appears in the audit trail if a value drops below the preset value. Since they are independent limits, a user has two different thresholds for alarming. (Typically, the LOLO value is set lower than the LO value to indicate that a condition has become worse. For certain input types, (i.e., 4-20 mA), the limit may also indicate an open circuit alarm.

Example: If the Hi alarm limit is set at 20.1°C for a tag, the alarm triggers as soon as value of the tag crosses 20.1°C.

IMPORTANT: *LabWatch LT requires the tag alarm state to clear before it institutes a new alarm delay. If the alarm delay has been set, changing the delay will not go into effect until that alarm clears.*

Open Circuit: Open Circuit means there is no sensor present or the sensor is broken.

Open/Close, On/Off and 1/0: For Digital tags (Contact switches), an open condition can be represented by Open, On or 1 and close condition can be represented by Close, Off or 0.

RSSI: RSSI is an abbreviation of Received Signal Strength Indicator. It's a measurement of the power present in a received radio signal. It tells the user how good or bad the RF signal is.

RSSI >-60 Connection Strength is considered good; -70 < and <-60 as OK; and <-70 is considered Bad

Under Range and Over Range: For 0-10v auxiliary input, any value less than 0 is Under Range and any value greater than 10 is Over Range. Similarly for 4-20mA auxiliary input, any value less than 4 is Under Range and any value greater than 20 is Over Range.

IMPORTANT: *Open Circuit, Over Range and Under Range alarms are all reported under Comm alarms in LabWatch LT.*

A

Add Graph	
for Daily Report	78
Alarm Configuration in Tag Maintenance	51
Annotation buttons	62
Area buttons	40
Audit Events button	83
Audit Trail Report, Creating An	83

B

Base Station	
Powering	5
Setting Up	5

C

Calibration History	84
Calibration Report, Creating a	84
Chart Configuration Tab	56
Color button for charts	62
Column Layout option	42
Comments button	43

D

Display Graph	
for Single Tag Report	82
Diva Analog 2p Board	
Installing	102
Diva Board	
Configuring	106
Testing	107
Diva® Analog Media Board	
Connecting	104

E

Email Service
 Requirements. 117
 Email Service, Installing 117
 Email Settings
 Configuring 118
 End Date
 for Audit Trail Report 83
 for Historical Report 79

F

Floor Plan Settings window 47
 Floor View. 47

G

Graph View 46
 Graphing Screen 53
 Group(s) and Tag(s)
 for Audit Trail Report 83
 for Historical Report 79
 for MKT Report 81
 for Single Tag Report 82
 Groups and Tags
 for Calibration Report 84

H

Historical Report, Creating a. 79

I

Installation. 3

L

LabWatch Lite	
Installation	3
LabWatch Lite Monitoring System	1
Legends and Readings	64
Limits button	63
List of Saved Templates	
for Historical Report	79
for MKT Report	81
for Single Tag Report	82
List View	40, 144, 145
Loggers	
Setting Network ID	14
Setting Up	14
Switching On or Off	14

M

Marker Properties	
in Graphing Screen	58
MKT Report, Creating a	81
Monitoring Screen	39
Monitoring Sensors	39

O

Open Circuit	42
Over Range	42

P

PCI Slot	103
PCIe Slot	103
Periods	
for MKT Report	81

R

Refresh button	61
Report Header	
for Daily Report	78
for Historical Report	80
for MKT Report	81
for Single Tag Report	82
Report Page Footer	
for Daily Report	78
for Historical Report	80
for MKT Report	81
for Single Tag Report	82
Report Page Header	
for Daily Report	78
for Historical Report	80
for MKT Report	81
for Single Tag Report	82
RF ValProbe	1
RF ValProbe, Operating	5
RJ10 Connector	105
RJ10 Ports	104
RJ11 Connector	105

S

Single Tag Alarm Report	82
Start Date	79
for Audit Trail Report	83
for MKT Report	81
for Single Tag Report	82
System Monitoring	39
System Monitoring Screen	40
System Requirements	3

T

Tabular Data Tab	50
Tag Maintenance option	42
Tag Maintenance Screen	49
Telephone Alarm Notification Process	115
Telephone Service	
Installing	101
Telephone Settings	
Configuring	110
Trending Tab	49

U

Under Range	42
User Account	
Configuring for Alarms	112
Configuring for Receiving Alarms	120

Y

Y-Axis tab	57
------------------	----

Z

Zoom buttons	61
--------------------	----

Customer Support Centers

U.S.A.

For Sales and Services (Repair/Calibration):

GE Measurement & Control
St Marys Center
967 Windfall Road
St Marys, Pennsylvania 15857
U.S.A.
T: 814-834-9140
F: 814-781-7969
stmaryscc@ge.com

U.S.A.

For Technical Support:

The Boston Center
1100 Technology Park Drive
Billerica, MA 01821
U.S.A.
T: 800-833-9438 (toll-free)
T: 978-437-1242
E-mail: validation.support@ge.com

Europe, Asia and Middle East Sales and Service:

GE Sensing & Inspection Technologies
GmbH
Sinsheimer Strasse 6
D-75179 Pforzheim
Germany
T: +49(0)7231-14335 0
F: +49(0)7212 391 035
E-mail: CCOPforzheim@ge.com

China:

GE Sensing & Inspection Technologies
Building 10, Jintong International
Industrial Park
No. 8 Xihu Road, Wujin High-Tech
Industrial Zone
Changzhou, China 213164
T:+86 519 8831 8080 ext. 50087
F:+86 519 8831 2601

www.ge-mcs.com/en/about-us/quality.html

www.ge-mcs.com

©2013 General Electric Company. All rights reserved.
Technical content subject to change without notice.

M4580 Rev. C

