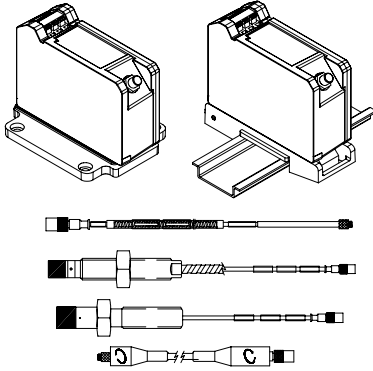


## 3300 XL NSv Proximity Transducer System

Patents: 5,016,343; 5,126,664; 5,351,388; 5,685,884



### Description

#### Transducer System

The 3300 XL NSv™ Proximity Transducer system is intended for use with centrifugal air compressors, refrigeration compressors, process gas compressors and other machines with tight installation requirements. The 3300 XL NSv™ Proximity Transducer System consists of:

- a 3300 NSv™ probe
- a 3300 NSv™ extension cable
- a 3300 XL NSv™ Proximator® Sensor.<sup>1</sup>

The primary uses for the 3300 XL NSv™ Transducer System are for areas where counter bore, sideview or rearview restrictions limit the use of standard Bently Nevada 3300 and 3300 XL 5 and 8 mm Transducer Systems. It is also ideal for small target applications, such as measuring radial vibration on shafts smaller than 51 mm (2 in) or axial position on flat targets smaller than 15 mm (0.6 in). It is primarily used in the following applications on fluid-filmed bearing machines where a small shaft or reduced side-view is present:

- Radial vibration and radial position measurements
- Axial (thrust) position measurements
- Tachometer and zero speed measurements
- Phase reference (Keyphasor®) signals

The 3300 XL NSv™ Transducer System design allows it to replace both the 3300 RAM Transducer Systems and the 3000-series or 7000-series 190 Transducer System. Upgrades from the 3300 RAM system to the 3300 XL NSv™ system may use the existing probe, extension cable, and monitoring system with 3300 XL NSv™ Proximator® Sensor. Upgrades from the 3000-series or 7000-series Transducer System must replace the probe, extension cable and Proximator® Sensor with NSv™ components.

The 3300 XL NSv™ Transducer System has an Average Scale Factor of 7.87 V/mm (200 mV/mil), which is the most common output for eddy current transducers. Its enhanced side-view and small target characteristics give it a shorter linear range than the Bently Nevada 3300 XL-series 5 and 8 mm Transducer System. With The 1.5 mm (60 mils) of linear range exceeds the linear range of the 3000-series 190 Transducer System.

**Application Alert:** Although the terminals and connector on the Proximator® Sensor have protection against electrostatic discharge, take reasonable precautions to avoid electrostatic discharge during handling.

---

## Proximito<sup>®</sup> Sensor

The 3300 XL NSv™ Proximito<sup>®</sup> Sensor has similar features to those found in the 3300 XL 8 mm Proximito<sup>®</sup> Sensor. Its thin design allows the user to mount it in either a high-density DIN-rail installation or a more traditional panel mount configuration. Improved RFI/EMI immunity allows the 3300 XL NSv™ Proximito<sup>®</sup> Sensor to achieve European CE mark approvals without any special mounting considerations. This RFI immunity also prevents nearby high frequency radio signals from adversely affecting the transducer system. SpringLoc terminal strips on the Proximito<sup>®</sup> Sensor require no special installation tools and facilitate faster, highly robust field wiring connections.

---

## Proximity Probe and Extension Cable

The 3300 NSv™ probe and extension cable are mechanically and electrically compatible and interchangeable with Bently Nevada's previous 3300 RAM proximity probe and extension cable. The NSv™ probe has increased chemical resistance compared to the 3300 RAM probe, which allows its use in many process compressor applications. The side-view characteristics of the 3300 NSv™ probe are also superior to those of the 3000-series 190 probe when gapping the 3300 NSv™ probe at the same distance from the probe target.

The 3300 NSv™ probe comes in varying probe case configurations, including armored and unarmored ¼ -28, ⅜ -24, M8 X 1 and M10 X 1 probe threads. The reverse mount 3300 NSv™ probe comes standard with either ⅜ -24 or M10 X 1 threads. All components of the transducer system have gold-plated brass ClickLoc™ connectors. ClickLoc™ connectors lock into place and prevent the connection from loosening. The patented TipLoc™ molding method provides a robust bond between the probe tip and the probe body. Bently Nevada's patented CableLoc™ design provides 220 N (50 lb) of pull strength and securely attaches the probe cable to the probe tip. Connector protectors are recommended for use on the probe-to-extension cable connection, as well as on the cable-to-Proximito<sup>®</sup> Sensor connection. Connector protectors prevent most liquids from entering into the ClickLoc™ connectors and adversely affecting the electrical signal<sup>2</sup>.

### Notes:

1. Proximito<sup>®</sup> Sensors are supplied by default from the factory calibrated to AISI 4140 steel. Calibration to other target materials is available upon request.
  2. Silicone tape is also provided with each 3300 NSv™ extension cable and can be used instead of connector protectors. Silicone tape is not recommended in applications where the probe-to-extension cable connection will be exposed to turbine oil.
- 

---

## Specifications

Unless otherwise noted, the following specifications are for a 3300 XL NSv™ Proximito<sup>®</sup> Sensor, extension cable and probe between 0°C and +45°C (+32°F to +113°F), with a -24 Vdc power supply, a 10 kΩ load, a Bently Nevada supplied AISI 4140 steel target that is 31 mm (1.2 in) diameter or larger, and a probe gap of 1.0 mm (40 mils). The system accuracy and interchangeability specifications do not apply when using a transducer system calibrated to any target other than a Bently Nevada AISI 4140 steel target.

---

## Electrical

### Proximito<sup>®</sup> Sensor Input

Accepts one non-contacting 3300 RAM or 3300 NSv™ Proximity Probe and Extension Cable.

### Power

Requires -17.5 Vdc to -26 Vdc without barriers at 12 mA maximum consumption, -23 Vdc to -26 Vdc with barriers. Operation at a more positive voltage than -23.5 Vdc can result in reduced linear range.

### Supply Sensitivity

Less than 2 mV change in output voltage per volt change in input voltage.

### Output resistance

50 Ω

### Probe dc resistance:

Probe Length (m)	Resistance from the Center Conductor to the Outer Conductor (R <sub>PROBE</sub> ) (ohms)
0.5	4.0 ± 0.5
1.0	4.2 ± 0.5
5.0	5.3 ± 0.7
7.0	5.9 ± 0.9

**Extension cable  
dc resistance:**

Center conductor: 0.220Ω/m (0.067 Ω/ft)

Shield: 0.066 Ω/m (0.020 Ω/ft)

**Extension cable  
capacitance:**

69.9 pF/m (21.3 pF/ft) typical

**Field wiring:**

0.2 to 1.5 mm<sup>2</sup> (16 to 24 AWG) [0.25 to 0.75 mm<sup>2</sup> (18 to 23 AWG) with ferrules]. Recommend using three-conductor shielded triad cable. Maximum length of 305 metres (1,000 feet) between the 3300 XL NSv™ Proximito® Sensor and the monitor. See the frequency response graphs Figure 16 and Figure 17 for signal rolloff at high frequencies when using longer field wiring lengths.

**Linear Range:**

1.5 mm (60 mils). Linear range begins at approximately 0.25 mm (10 mils) from target and is from 0.25 to 1.75 mm (10 to 70 mils) (approximately -1 to -13 Vdc).

**Recommended  
Gap Setting:**

1.0 mm (40 mils)

**System performance over ambient temperature  
range (0°C to 45°C):**

*Incremental Scale  
Factor (ISF)*

7.87 V/mm (200 mV/mil) +12.5%/-20% including interchangeability error when measured in increments of 0.25 mm (10 mils) over the 1.5 mm (60 mil) linear range.

*Deviation from best  
fit straight line  
(DSL)*

Less than ±0.06 mm (±2.3 mils).

**Frequency  
Response:**

0 to 10 kHz: +0, -3 dB typical, with up to 305 metres (1000 feet) of field wiring.

**Target Size (flat  
target):**

Minimum: 8.9 mm (0.35 in) diameter

Recommended minimum: 13 mm (0.5 in) diameter

Axial position measurements on shaft diameters smaller than 13mm (0.5 in) will generally result in a change in scale factor. Reducing the gap between the probe and target will help limit the change in scale factor. See Figure 12 for additional information.

**Shaft Diameter**

Minimum (standard X-Y probe configuration): 30 mm (1.2 in)

Minimum (X-Y proximity probes offset axially by 23 mm (0.9 in)): 20 mm (0.8 in)

Measurements on shaft diameters smaller than 30 mm (1.2 in) usually require close spacing of radial vibration or axial position transducers. This creates the potential for their electromagnetic emitted fields to interact with one another (cross-talk), resulting in erroneous readings. To prevent cross-talk, maintain minimum separation of transducer tips of at least 25 mm (1.0 in) for axial position measurements or 23 mm (0.9 in) for radial vibration measurements (see Figure 14 and Figure 15 for additional information.) Radial vibration or radial position measurements on shaft diameters smaller than 20 mm (0.8 in) will generally result in greater than a 10% change in Average Scale Factor (ASF). See Figure 13 for additional information.

**Counterbore**

Minimum: 9.5 mm (0.375 in)

Recommended minimum: 13 mm (0.5 in)

Counterbores smaller than 13 mm (0.5 in) generally result in a change in scale factor at far gaps. Reducing the gap between the probe and the target will allow the transducer system to maintain its Average Scale Factor (ASF) over a reduced linear range. See Figure 9 for additional information.

## Effects of 60 Hz Magnetic Fields Up to 300 Gauss (5 metre system):

Output voltage in mil pp/gauss:

Gap	Proximito <sup>®</sup> Sensor	Probe	Ext. Cable
0.25 mm (10 mils)	0.006	0.001	0.001
1.0 mm (40 mils)	0.007	0.002	0.001
1.75 mm (70 mils)	0.008	0.002	0.003

### Electrical Classification:

Complies with the European CE mark.

### Hazardous Area Approvals

Multiple approvals for hazardous areas certified by Canadian Standards Association (CSA/NRTL/C) in North America and by BASEEFA/CENELEC in Europe.

#### North America:

Ex ia IIC T5; Class I Zone 0 or Exia IIC T5 for Class 1 Division 1; Groups A, B, C, and D, when installed with intrinsically safe zener barriers per drawing 141092 or when installed with galvanic isolators.

ExnA IIC T5 Class I Zone 2 or ExnA IIC T5 for Class I, Division 2, Groups A, B, C, and D when installed without barriers per drawing 140979.

T<sub>5</sub> @ T<sub>a</sub> = -35°C to +85°C.

#### Europe:

EExia IIC T5 for Zones 0, 1 and 2, Group IIC, BASEEFA certificate number BAS99ATEX1101, when installed with intrinsically safe zener barriers or galvanic isolators,

T<sub>5</sub> @ T<sub>a</sub> = -35°C to +85°C.

EEx nA for Zone 2, Group IIC, BASEEFA certificate number BAS99ATEX3100U.

### Mechanical

#### Probe Tip Material:

Polyphenylene sulfide (PPS).

#### Probe Case Material:

AISI 304 stainless steel (SST).

#### Probe Cable Specifications:

75 Ω coaxial, fluoroethylene propylene (FEP) insulated probe cable in the following total probe lengths: 0.5, 1, 5, or 7 metres.

#### Extension Cable Material:

75 Ω coaxial, fluoroethylene propylene (FEP) insulated.

#### Proximito<sup>®</sup> Sensor Material:

A380 aluminum

#### System Length:

5 or 7 metres including extension cable

#### Extension Cable Armor (optional):

Flexible AISI 302 SST with/without FEP outer jacket.

#### Tensile Strength (maximum rated):

220 N (50 lb) probe case to probe lead.  
220 N (50 lb) at probe lead to extension cable connectors.  
220 N (50 lb) probe case to stainless steel armor.

#### Connector material:

Gold-plated brass

## Connector-to-connector torque

Probe case torque:	Maximum Rated	Recommended
¼ -28 or M8x1 probe cases	7.3 N•m (65 in•lb)	5.1 N•m (45 in•lb)
3/8-24 or M10x1 probe cases	33.9 N•m (300 in•lb)	11.3 N•m (100 in•lb)
3/8-24 or M10x1 probe cases – first three threads	22.6 N•m (200 in•lb)	7.5 N•m (66 in•lb)
Reverse mount probes	22.6 N•m (200 in•lb)	7.5 N•m (66 in•lb)

### Recommended

torque: *Finger tight*

Maximum torque: *0.56 N•m (5 in•lb)*

### Minimum Bend

#### Radius (with or without

sst armor): 25.4 mm (1.0 in)

### System Weight (typical):

Probe: *Approximately 14 to 150 g (0.5 to 5.3 oz)*

Extension Cable: *45 g/m (0.5 oz/ft)*

#### Armored Extension

Cable: *64 g/m (0.7 oz/ft)*

#### Proximator®

Sensor: *255 g (9 oz)*

## Environmental Limits

### Probe Temperature Range

#### Operating

Temperature: *-34°C to +177°C (-30°F to +351°F)*

#### Storage

Temperature: *-51°C to +177°C (-60°F to +351°F)*

**Note:** Exposing the probe to temperatures below -34°C (-30°F) for a sustained period of time may cause premature failure of the pressure seal.

## Extension Cable Temperature Range

### Operating and Storage

Temperature: *-51°C to +177°C (-60°F to +351°F)*

## Proximator® Sensor Temperature Range

### Operating

Temperature: *-35°C to +85°C (-31°F to +185°F)*

### Storage

Temperature: *-51°C to +105°C (-60°F to +221°F)*

## Relative Humidity:

100% condensing, non-submersible when connectors are protected. Tested to IEC 68-2-3 damp heat.

## Probe Pressure:

3300 NSv™ probes are designed to seal differential pressure between the probe tip and case. The probe sealing material consists of a Viton® O-ring. Probes are not pressure tested prior to shipment. Contact our custom design department if you require a test of the pressure seal for your application

**Note:** It is the responsibility of the customer or user to ensure that all liquids and gases are contained and safely controlled should leakage occur from a proximity probe. In addition, solutions with high or low pH values may erode the tip assembly of the probe causing media leakage into surrounding areas. Bently Nevada LLC will not be held responsible for any damages resulting from leaking 3300 NSv™ Proximity Probes. In addition, 3300 NSv™ Proximity Probes will not be replaced under the service plan due to probe leakage.

## Patents:

5,016,343

5,126,664

5,351,388

5,685,884

Components or procedures described in these patents apply to this product.

---

## Ordering Information

---

### 3300 NSv™ Proximity Probes

330901 3300 NSv™ Probe, 1/4-28 UNF thread, without armor

330902 3300 NSv™ Probe, 1/4-28 UNF thread, with armor

330908 3300 NSv™ Probe, 3/8-24 UNF thread, without armor

330909 3300 NSv™ Probe, 3/8-24 UNF thread, with armor

#### Part Number-AXX-BXX-CXX-DXX-EXX

#### Option Descriptions

##### A: Unthreaded Length Option

**Note:** Unthreaded length must be at least 0.7 inch less than the case length.

Order in increments of 0.1 in

Length configurations:

**Maximum unthreaded length:** 9.2 in

**Minimum unthreaded length:** 0.0 in

**Example:** 0 4 = 0.4 in

##### B: Overall Case Length Option

Order in increments of 0.1 in

Threaded length configurations:

**Maximum case length:** 9.9 in

**Minimum case length:** 0.8 in

**Example:** 2 4 = 2.4 in

##### C: Total Length Option

**0 5** 0.5 metre (20 in)

**1 0** 1.0 metre (39 in)

**5 0** 5.0 metres (16.4 feet)

**7 0** 7.0 metres (23.0 feet)

##### D: Connector and Cable-Type Option

**0 1** Miniature coaxial ClickLoc™ connector with connector protector, standard cable

**0 2** Miniature coaxial ClickLoc™ connector, standard cable

**1 1** Miniature coaxial ClickLoc™ connector with connector protector, FluidLoc® cable

**1 2** Miniature coaxial ClickLoc™ connector, FluidLoc® cable

##### E: Agency Approval Option

**0 0** Not required

**0 5** Multiple Approvals

---

### 3300 NSv™ Proximity Probes, Metric

330903 3300 NSv™ Probe, M8 x 1 thread, without armor

330904 3300 NSv™ Probe, M8 x 1 thread, with armor

330905 3300 NSv™ Probe, M10 x 1 thread, without armor

330910 3300 NSv™ Probe, M10 x 1 thread, with armor

#### Part Number-AXX-BXX-CXX-DXX-EXX

#### Option Descriptions

##### A: Unthreaded Length Option

**Note:** Unthreaded length must be at least 20 mm less than the case length.

Order in increments of 10 mm.

**Length configuration:**

**Maximum unthreaded length:** 230 mm

**Minimum unthreaded length:** 0 mm

**Example:** 0 6 = 60 mm

##### B: Overall Case Length Option

Order in increments of 10 mm.

**Metric thread configurations:**

**Maximum length:** 250 mm

**Minimum length:** 20 mm

**Example:** 0 6 = 60 mm

##### C: Total Length Option

**0 5** 0.5 metre (20 in)

**1 0** 1.0 metre (39 in)

**5 0** 5.0 metres (16.4 feet)

**7 0** 7.0 metres (23.0 feet)

##### D: Connector and Cable-Type Option

- 0 1 Miniature coaxial ClickLoc™ connector with connector protector, standard cable
- 0 2 Miniature coaxial ClickLoc™ connector, standard cable
- 1 1 Miniature coaxial ClickLoc™ connector with connector protector, FluidLoc® cable
- 1 2 Miniature coaxial ClickLoc™ connector, FluidLoc® cable

- 5 0 5.0 metre (16.4 feet) system length, panel mount
- 5 1 5.0 metre (16.4 feet) system length, DIN mount
- 5 2 5.0 metre (16.4 feet) system length, no mounting hardware<sup>1</sup>
- 7 0 7.0 metres (23.0 feet) system length, panel mount
- 7 1 7.0 metres (23.0 feet) system length, DIN mount
- 7 2 7.0 metres (23.0 feet) system length, no mounting hardware<sup>1</sup>

E: Agency Approval Option

- 0 0 Not required
- 0 5 Multiple Approvals

**3300 NSv™ Reverse Mount Probe**

330906-02-12- CXX-DXX-EXX, 3/8-24 UNF threads

330907-05-30- CXX-DXX-EXX, M10 x 1 threads

**Option Descriptions**

C: Total Length Option

- 0 5 0.5 metre (20 in)
- 1 0 1.0 metre (39 in)
- 5 0 5.0 metres (16.4 feet)
- 7 0 7.0 metres (23.0 feet)

D: Connector Option

- 0 2 Miniature coaxial ClickLoc™ connector, standard cable
- 1 2 Miniature coaxial ClickLoc™ connector, FluidLoc® cable

E: Agency Approval Option

- 0 0 Not required
- 0 5 Multiple Approvals

**Note:** For a shorter delivery time, order commonly stocked probes. Currently, stocked probes consist of the following part numbers: 330901-00-24-05-02-00, 330901-00-90-05-02-00, 330902-00-50-05-02-00, 330902-00-95-05-02-00, 330903-00-02-10-02-00, 330903-00-03-10-02-00, 330906-02-12-05-02-00.

**3300 XL NSv™ Proximito® Sensor**

330980-AXX-BXX

**Option Descriptions**

A: Total Length and Mounting Option

B: Agency Approval Option

- 0 0 Not required
- 0 5 Multiple approvals

**3300 NSv™ Extension Cable**

330930-AXXX-BXX-CXX

**Note:** Make sure that the extension cable length and the probe length, when added together, equal the Proximito® Sensor total length.

**Option Descriptions**

A: Cable Length Option

- 0 4 0 4.0 metres (13.1 feet)
- 0 4 5 4.5 metres (14.8 feet)
- 0 6 0 6.0 metres (19.7 feet)
- 0 6 5 6.5 metres (21.3 feet)

B: Connector and Cable Option

- 0 0 Without stainless steel armor
- 0 1 With stainless steel armor, with FEP jacket
- 0 2 With stainless steel armor, without FEP jacket
- 0 3 Without stainless steel armor, with connector protectors
- 0 4 With stainless steel armor, with FEP jacket, with connector protectors
- 0 5 With stainless steel armor, without FEP jacket, with connector protectors

C: Agency Approval Option

- 0 0 Not required
- 0 5 Multiple Approvals

136536-01

**Connector Protector Adapter.** Connector Protector Adapter. Allows connector protector installation tools manufactured prior to 1998 to be used with 75 Ω ClickLoc™ connectors.

40180-03

**Connector Protectors.** Package contains 10 pairs of connector protectors.

03800000

**Male Connector Protector.** Placed on the extension cable to connect to the female connector protector on the probe and provide environmental protection of connectors.

03800001

**Female Connector Protector.** Placed on the probe lead to connect to the male connector protector on the extension cable and provide environmental protection of connectors. Also placed on the extension cable to slide over the Proximator® Sensor connection and protect it from the environment.

330153-05

**3300 NSv™ Connector Kit.** Used on 3300 NSv™ probes and extension cables. Contains one set of male and female ClickLoc™ connectors, sleeves and one strip of silicone tape.

163356

**Connector Crimp Tool Kit.** Includes one set of 75 Ω ClickLoc™ inserts and connector installation instructions. Supplied with carrying case.

**Notes:**

1. 330980 Proximator® Sensor A: options 52 and 72 come without a mounting pad and should be ordered only as spares. Each Proximator® Sensor needs a mounting pad to ensure that it is properly isolated from the housing ground.

**Accessories**

147357-01

**Manual**

02120015

**Bulk field wire.** 1.0 mm<sup>2</sup> (18 AWG), 3 conductor, twisted, shielded cable with drain wire. Specify length in feet.

138492-01

**Replacement panel-mount mounting pad**

138493-01

**Replacement DIN-mount mounting pad**

01609137

**BNC (F) to banana plugs**

01609138

**Proximator® Connector Test Pin wiring** (two test pins to a BNC (F) connector)

40971-04

**50 Ω cable with two BNC (M) connectors.** Use this cable in combination with adapter 01609137 and adapter 01609138 when checking performance of the transducer system from the Proximator® Sensor test pin holes.

04310310

**3300 XL Proximator® Sensor Panel-mount Screws.** Package includes one 6-32 UNC thread forming mounting screw (Supplied standard with 3300 XL Proximator® Housings [3300 XL option] ).

03200006

**Silicone self-fusing tape.** A 9.1 metre (10 yard) roll of silicone tape to protect connectors. It is easy to install and provides excellent electrical isolation and protection from the environment. It is not recommended for use inside the casing of the machine.

40113-03

**Connector Protector Kit.** Connector Protector Kit for 3300 NSv™ probes and extension cables, including connector protectors and installation tools.

© 2001 Bently Nevada, LLC.  
 CableLoc™, ClickLoc™, FluidLoc®, Keyphasor®, NSv™, Proximator®, and TipLoc™ are trademarks of Bently Nevada, LLC.  
 Viton® is a trademark of DuPont.

# Graphs and Dimensional Drawings

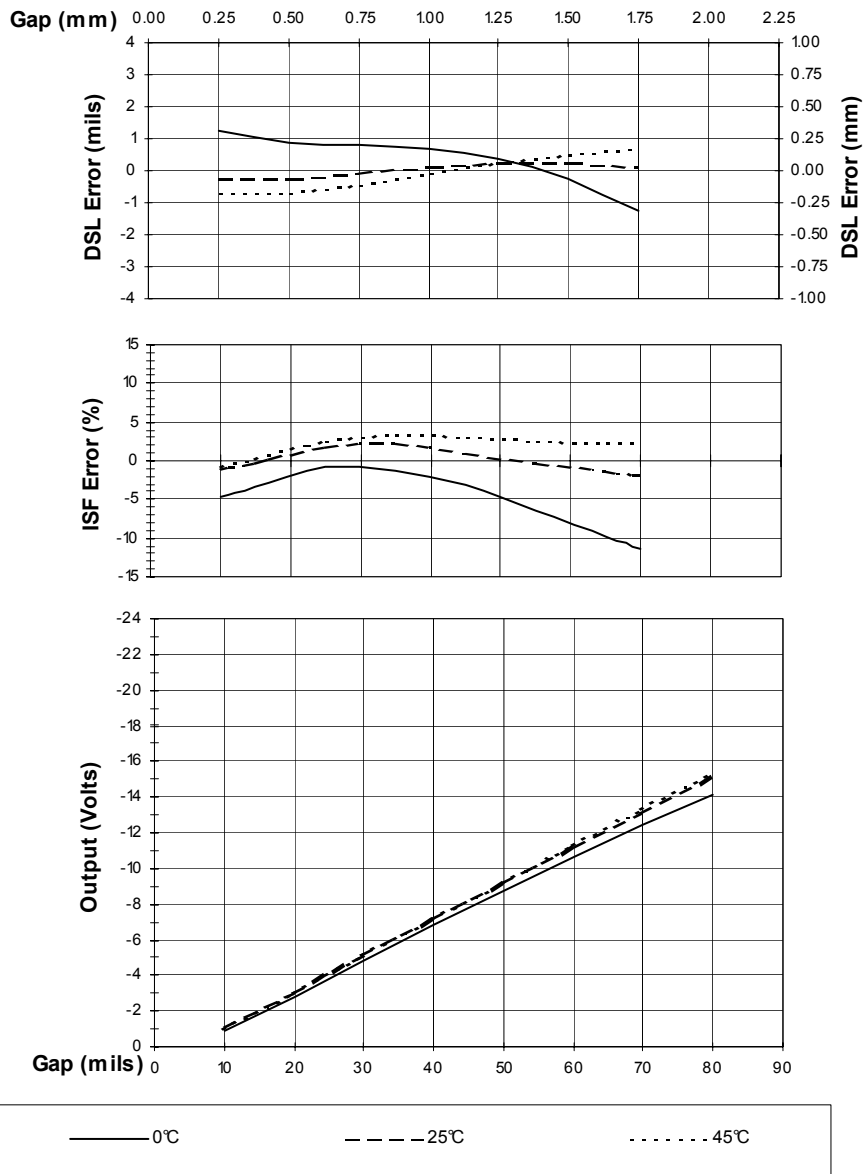
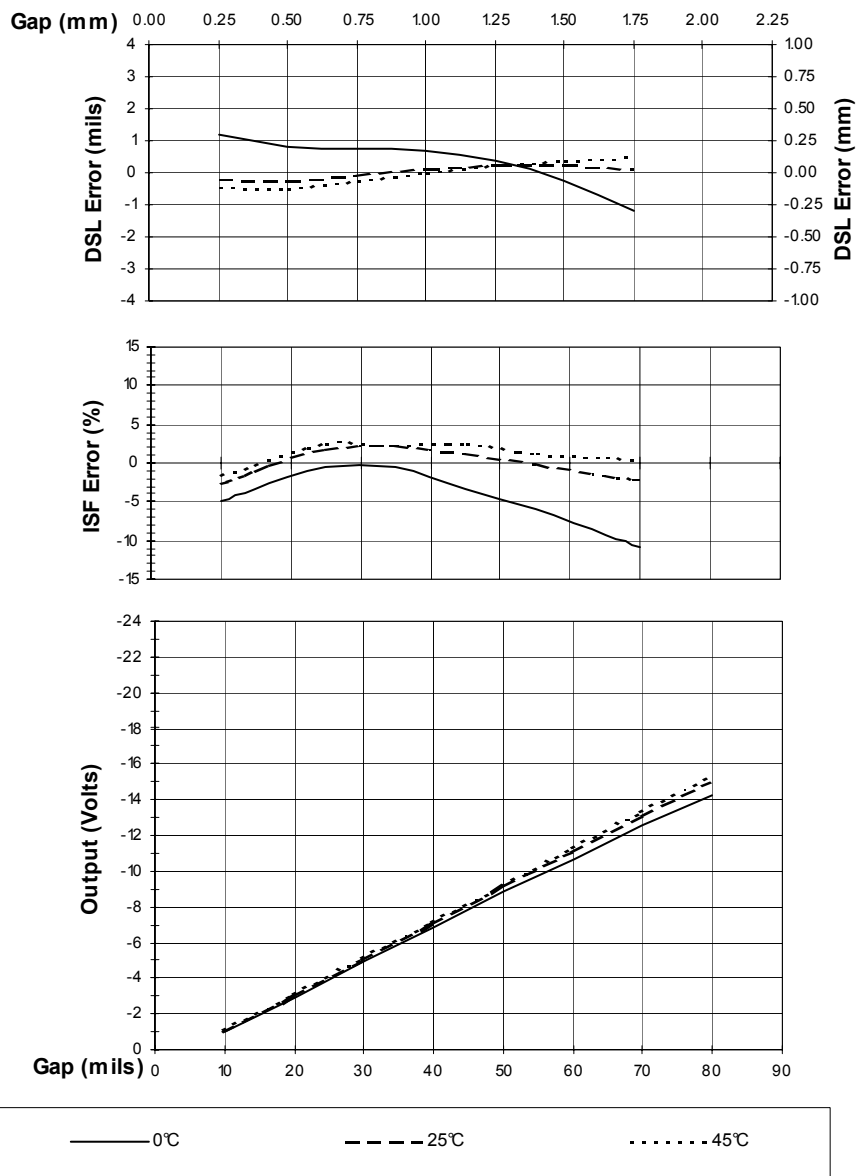
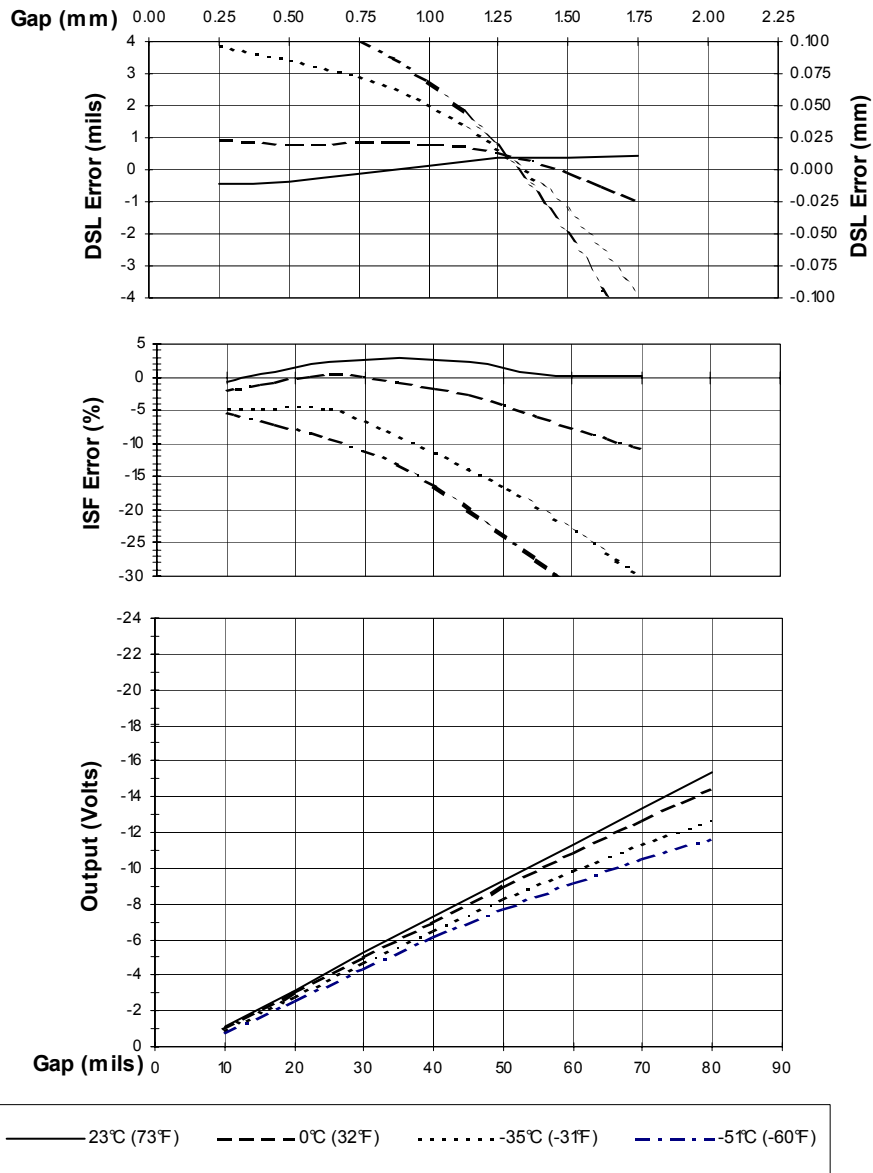


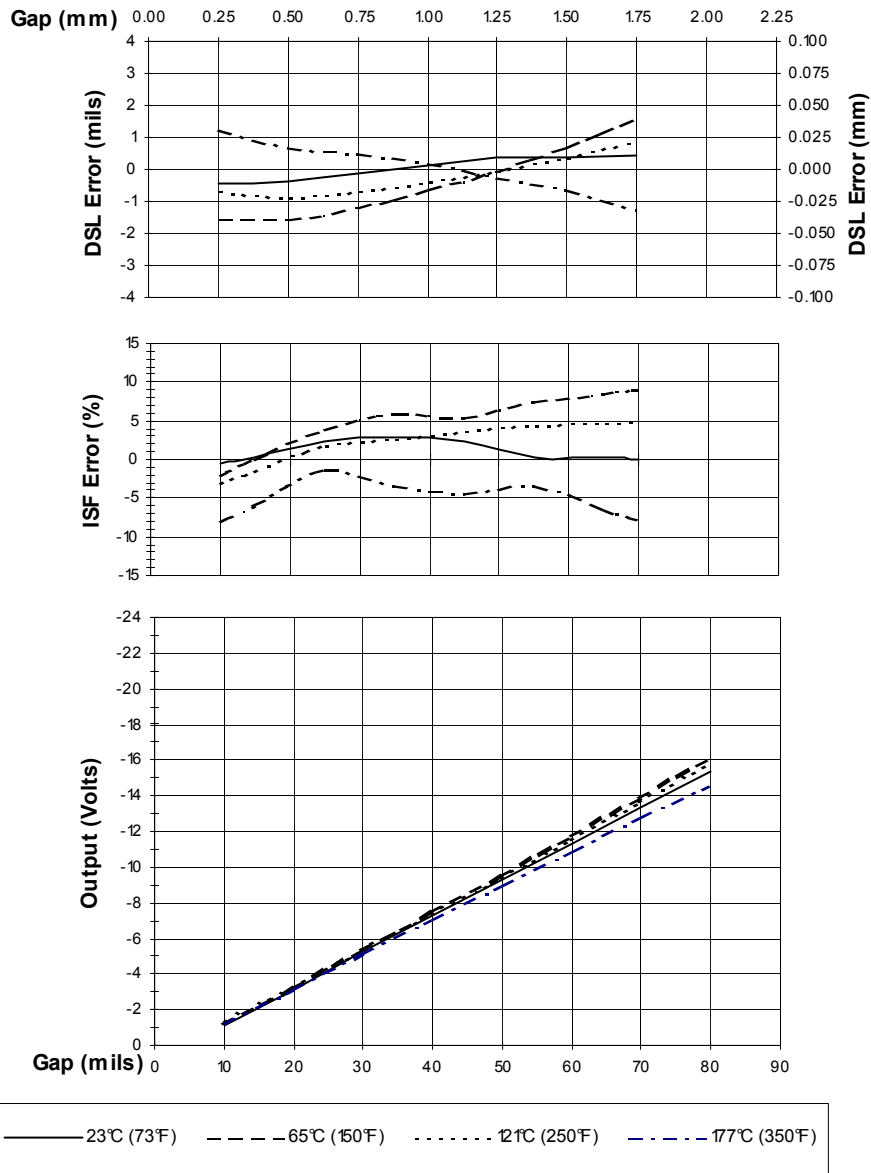
Figure 1 Typical 3300 XL NSv™ 5 m System Over Ambient Temperature Range



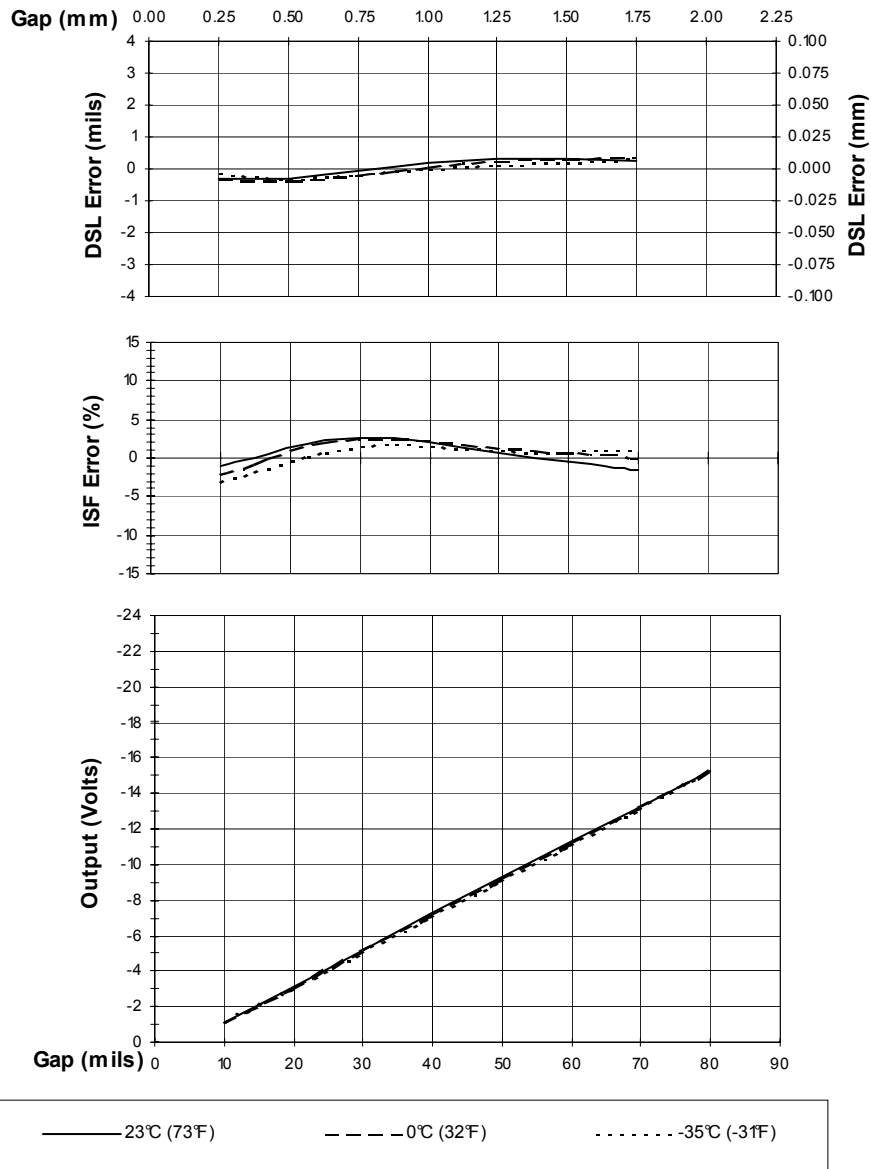
**Figure 2 Typical 3300 XL NSv™ 7 m System Over Ambient Temperature Range**



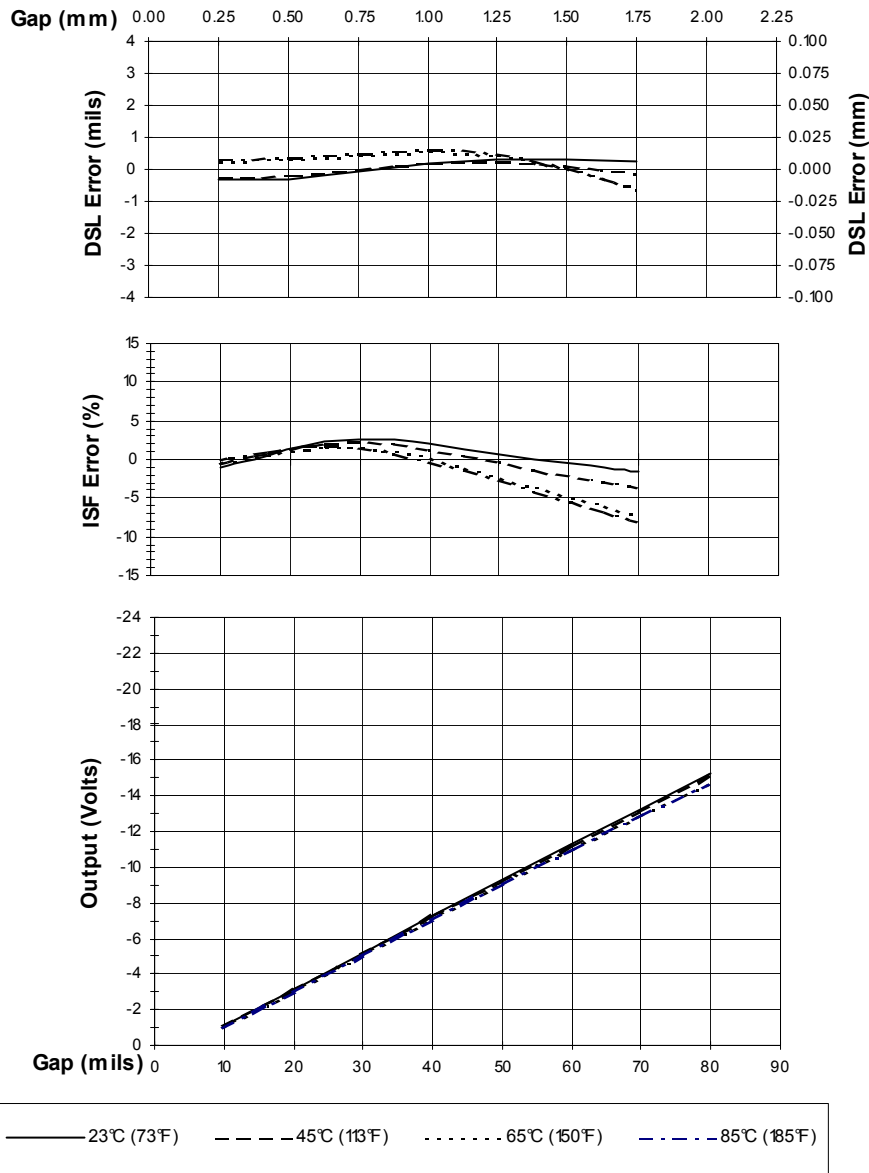
**Figure 3 Typical 3300 NSv™ Probe + 1m Cable @ Low Temperature (Proximator® Sensor + 4m of Extension Cable @ 25 °C)**



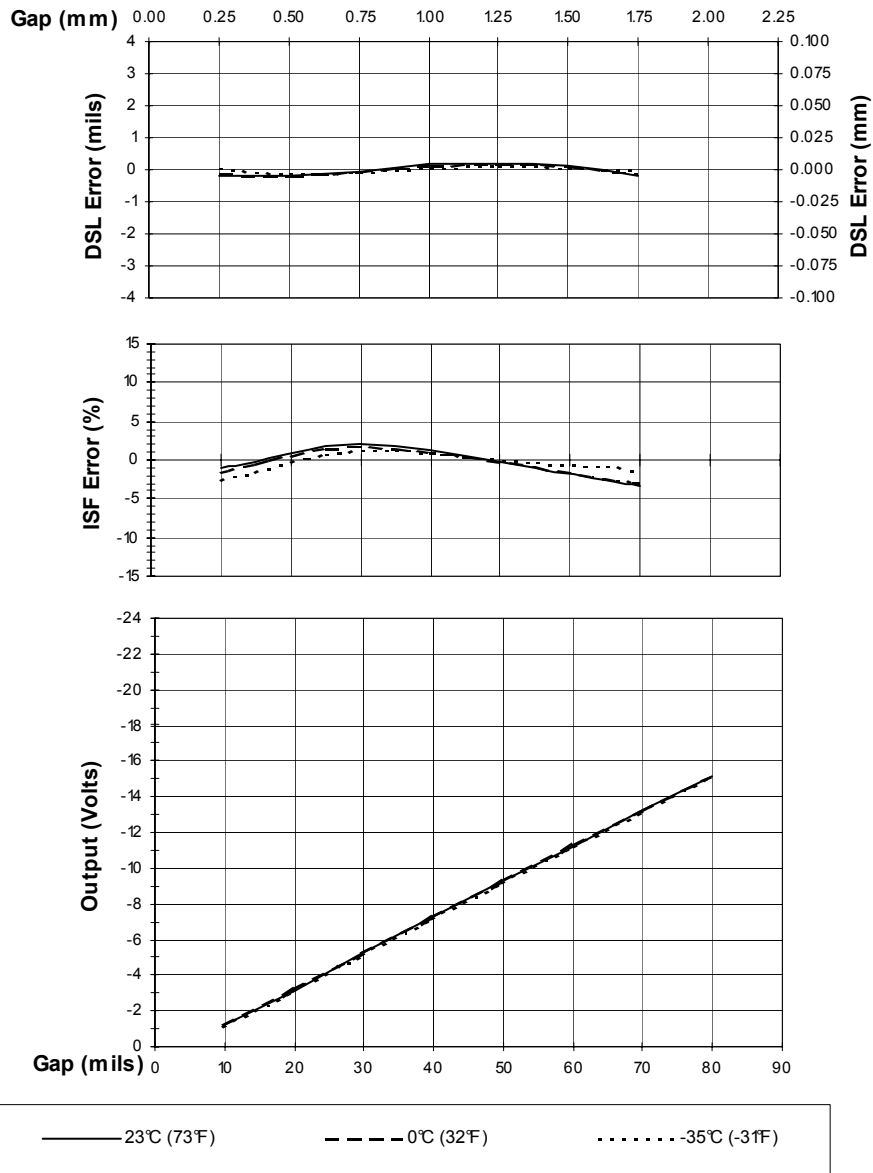
**Figure 4 Typical 3300 NSv™ Probe + 1m Cable @ High Temperature (Proximitytor® Sensor + 4m of Extension Cable @ 25 °C)**



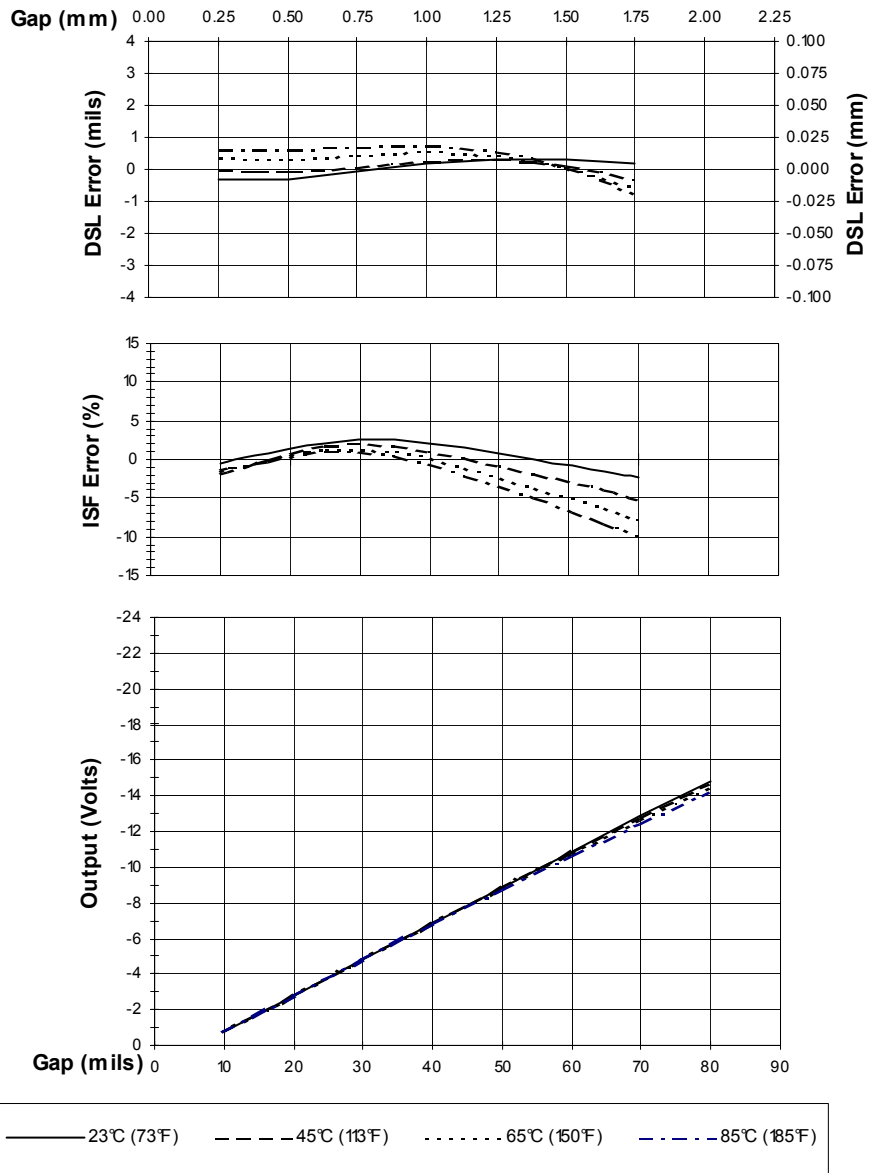
**Figure 5 Typical 3300 XL NSv™ 5 m Proximity® Sensor with 4 m of Extension Cable @ Low Temperature (Probe is at 25°C)**



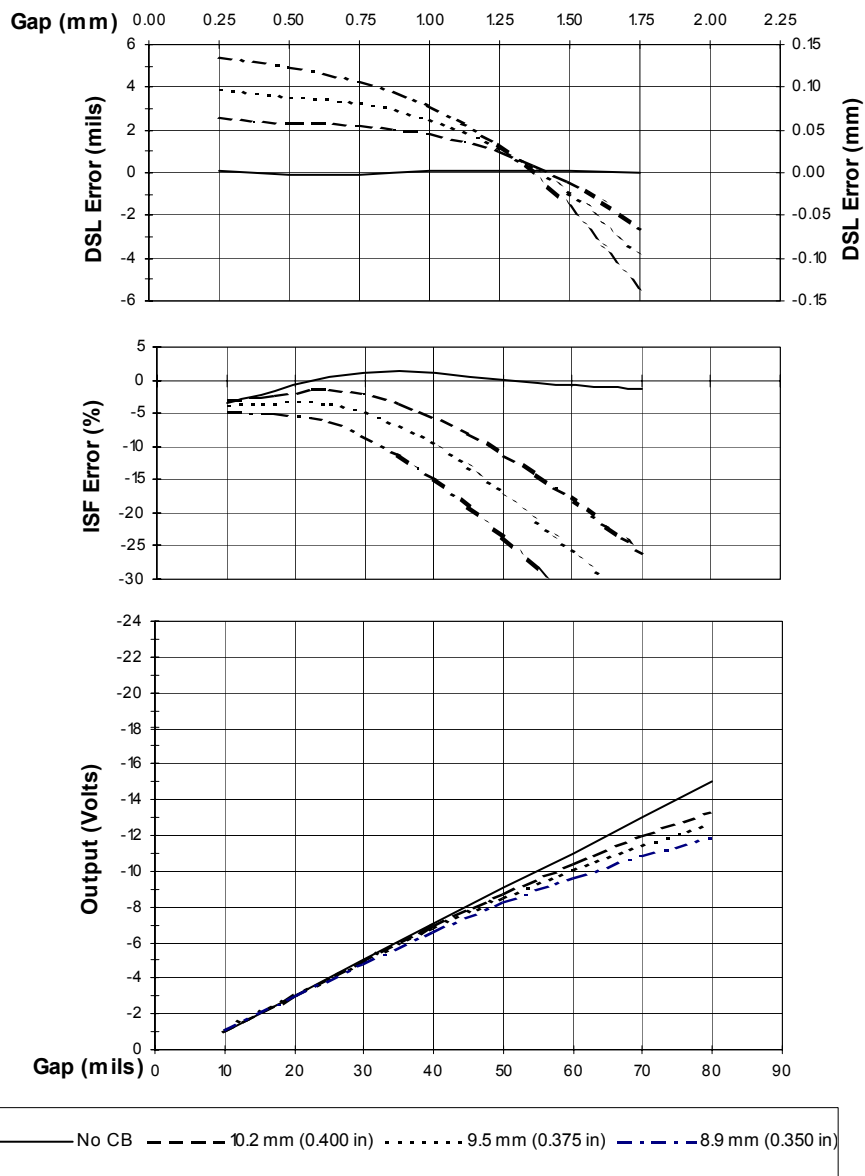
**Figure 6 Typical 3300 XL NSv™ 5 m Proximity® Sensor with 4 m Extension Cable @ High Temperature (Probe is at 25°C)**



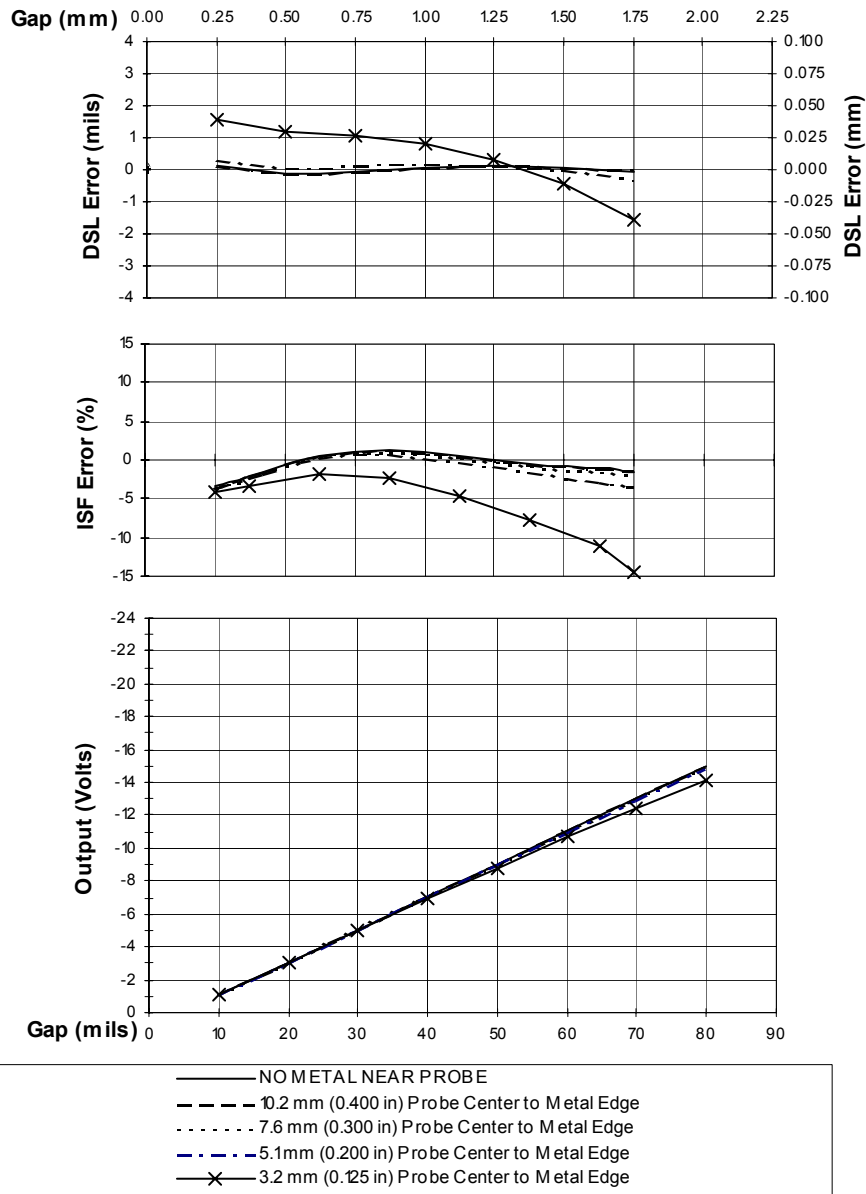
**Figure 7 Typical 3300 XL NSv™ 7 m Proximator® Sensor with 6 m of Extension Cable @ Low Temperature (Probe is at 25°C)**



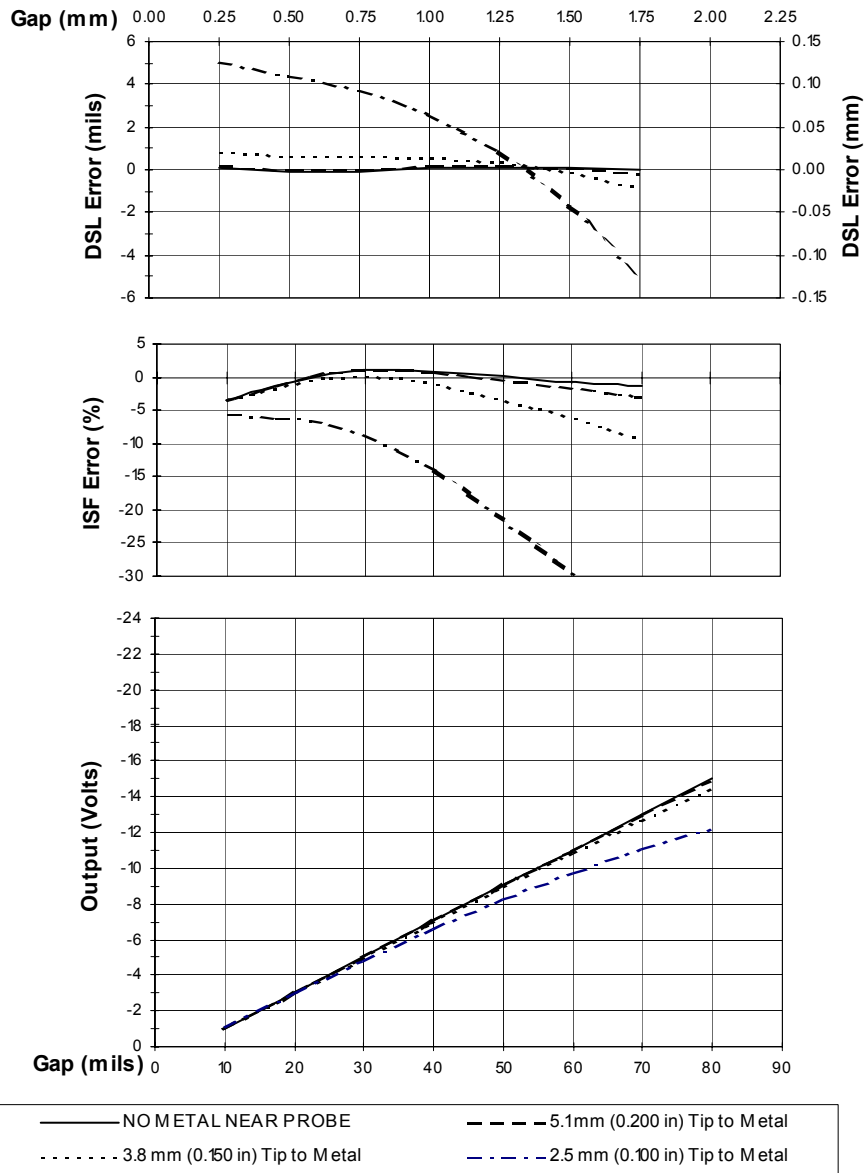
**Figure 8 Typical 3300 XL NSv™ 7 m Proximator® Sensor with 6 m of Extension Cable @ High Temperature (Probe is at 25°C)**



**Figure 9 Effect of Counterbore Side Clearance (4140 Material)**



**Figure 10 Effect of Flat Surface Side Clearance (4140 Material)**



**Figure 11 Effect of Rear Surface Clearance (4140 Material)**

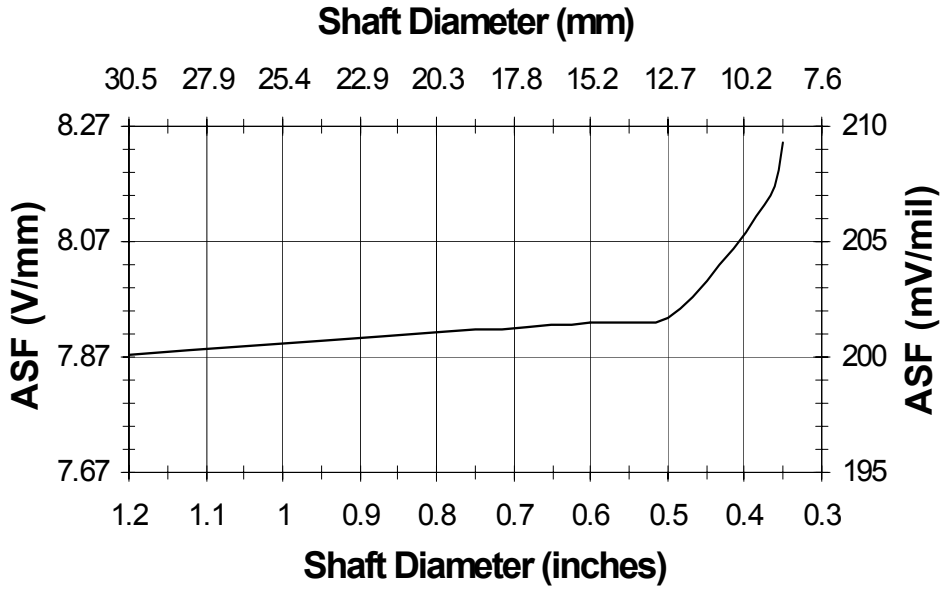


Figure 12 Axial Sensitivity to Shaft Size

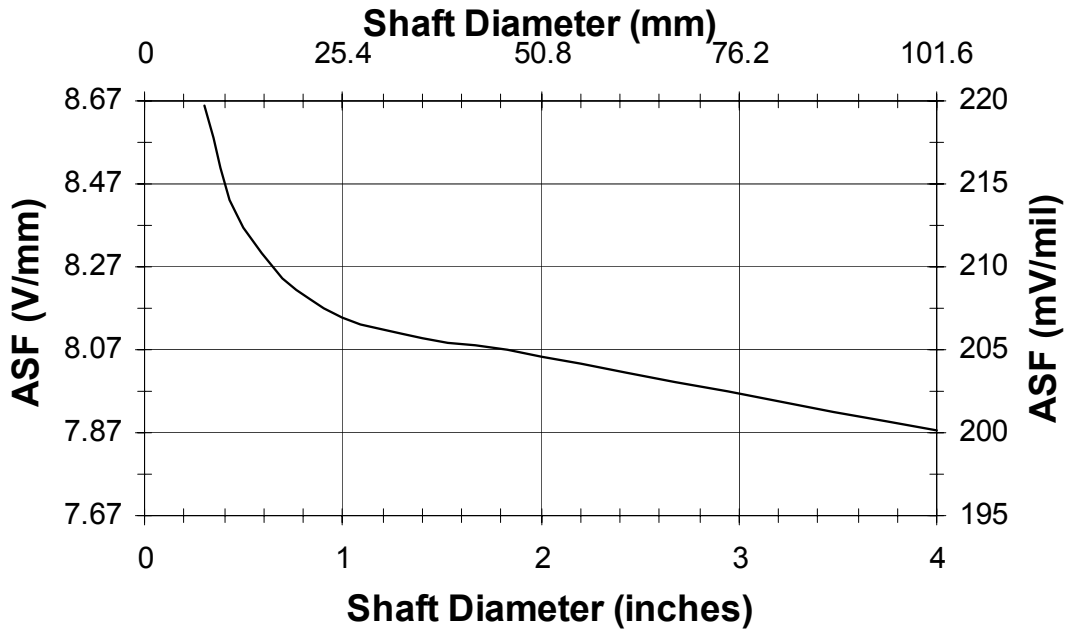
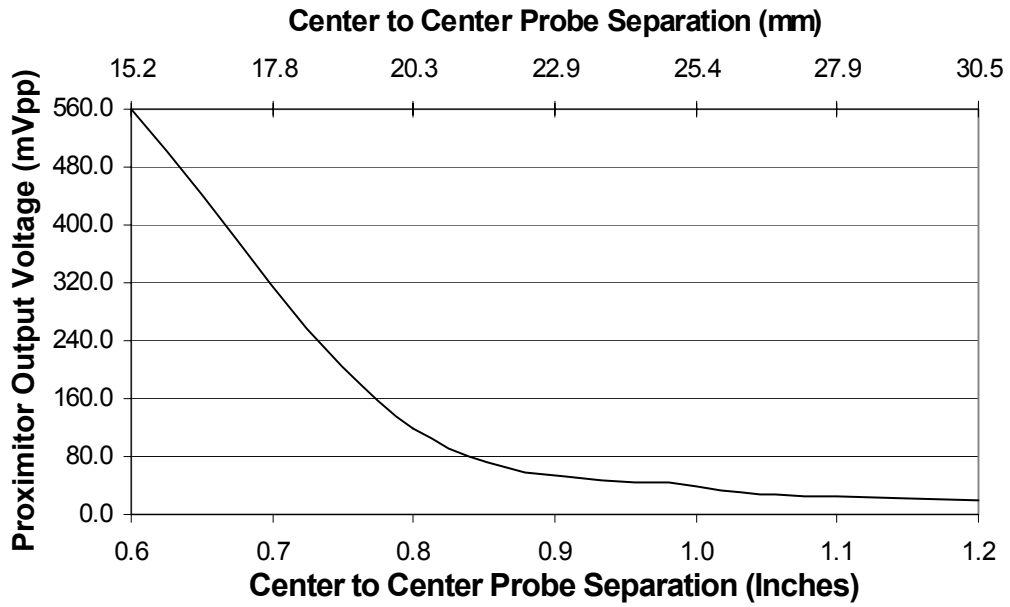
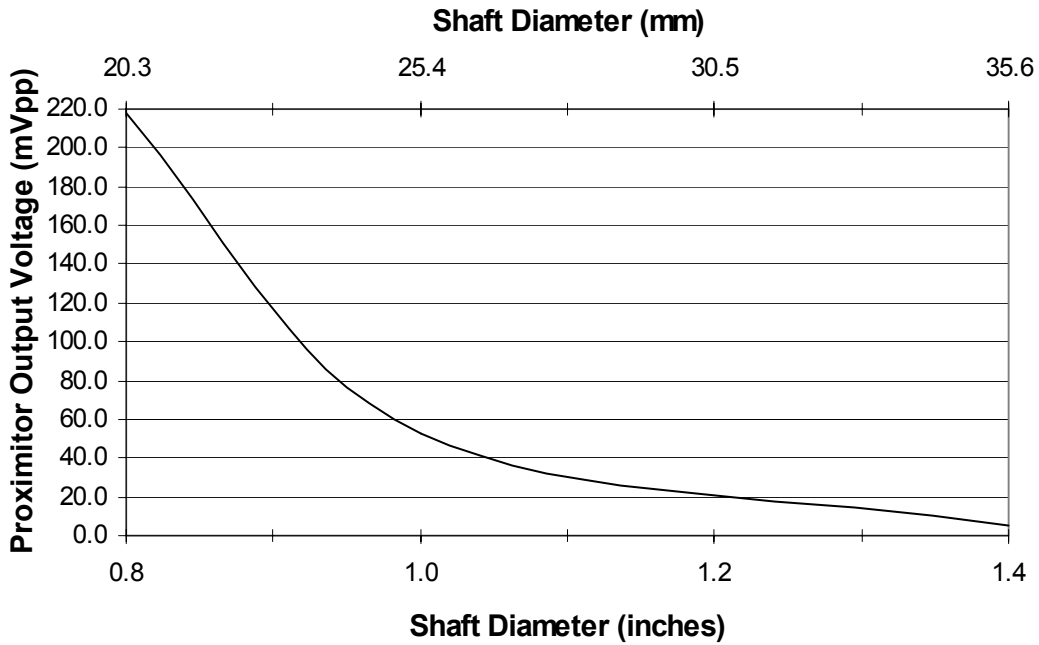


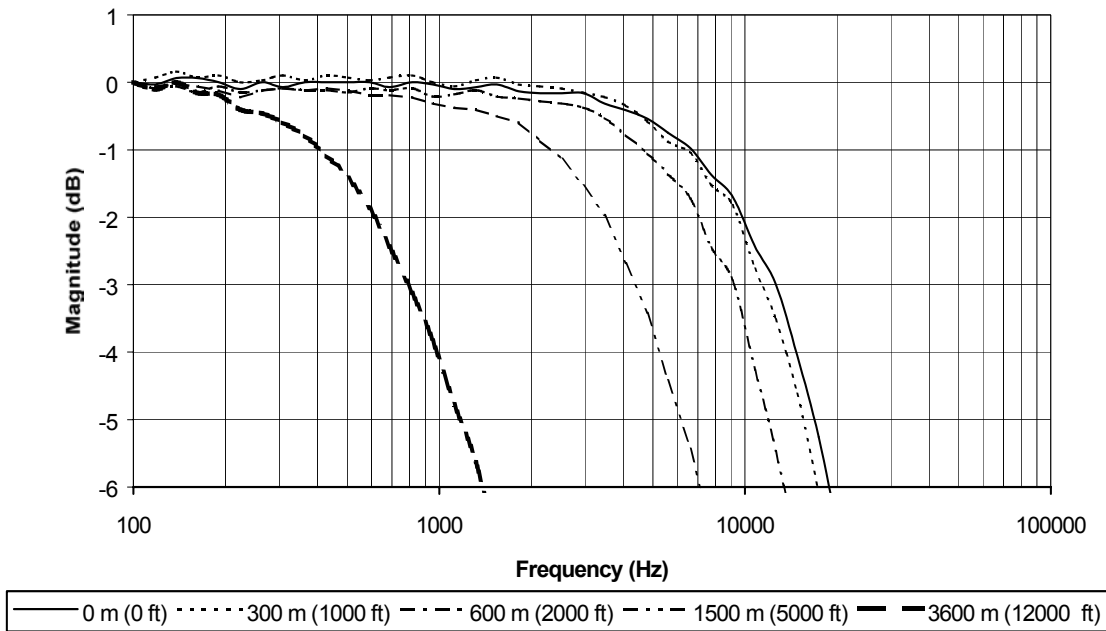
Figure 13 Radial Sensitivity to Shaft Size



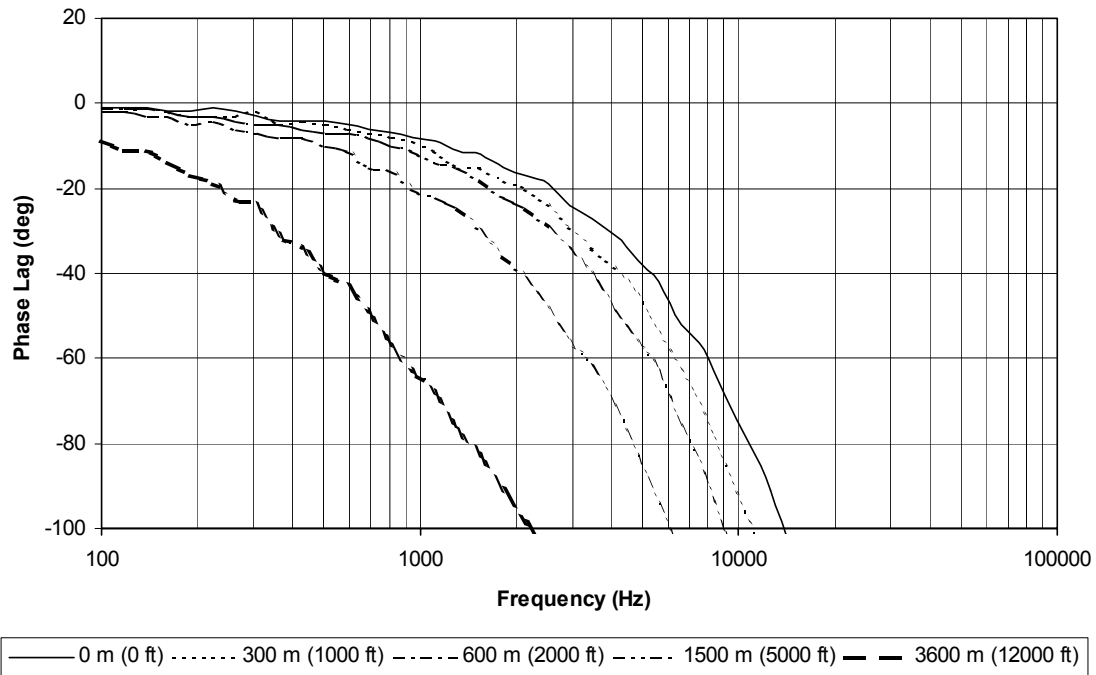
**Figure 14 Probe Cross-talk with Probes Mounted in Parallel**



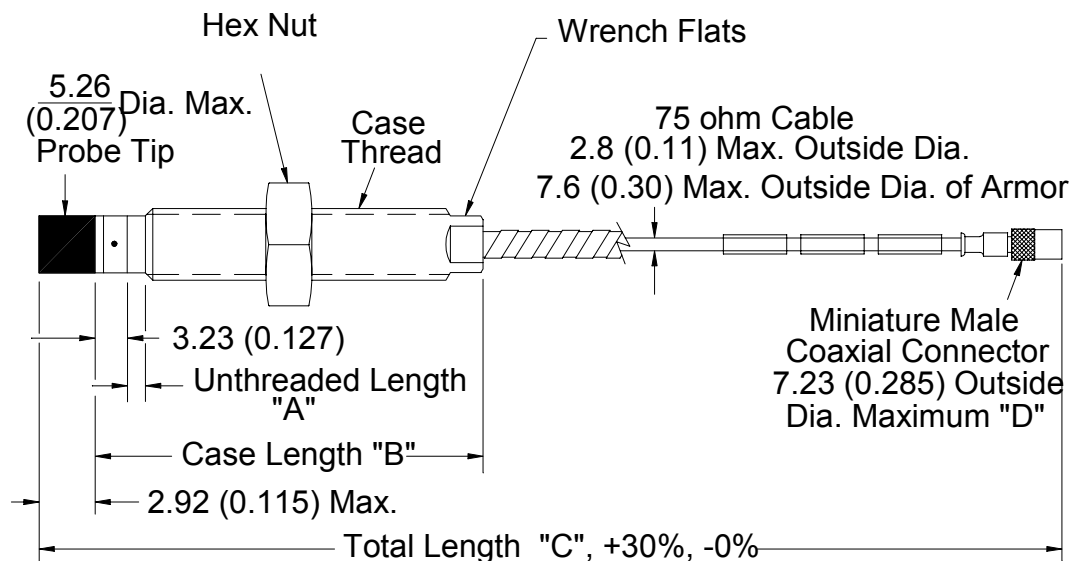
**Figure 15 Probe Cross-talk with Probes Mounted in X-Y Configuration**



**Figure 16 Frequency Response, magnitude of typical 3300 XL NSv™ System with various lengths of field wiring, no barriers**

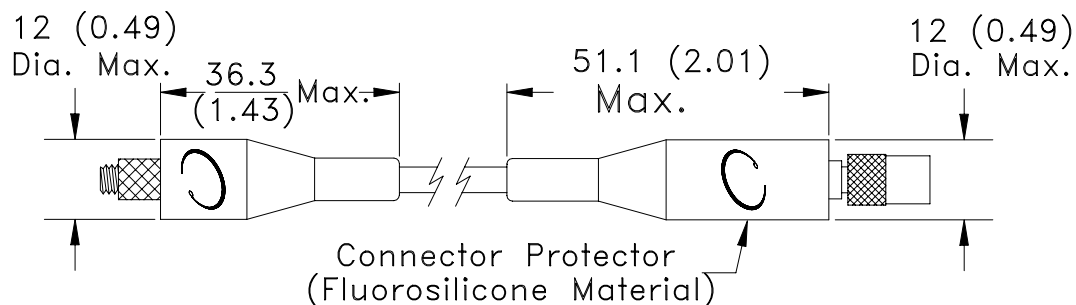


**Figure 17 Frequency Response, phase change of typical 3300 XL NSv™ System with various lengths of field wiring, no barriers**

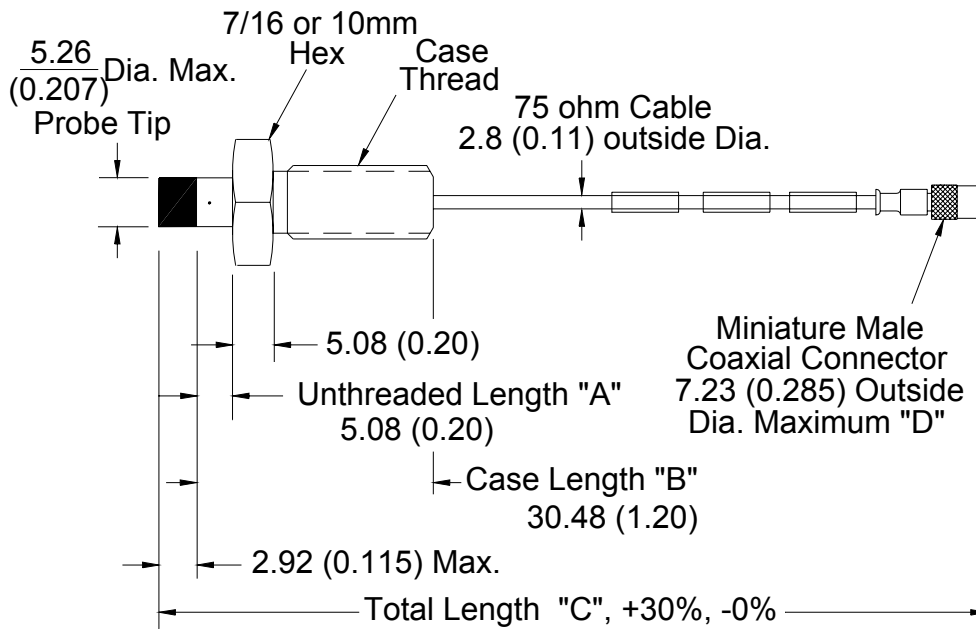


**Figure 18 3300 NSv™ Proximity probes, Standard Mount**

- 330901, ¼ -28 UNF-2A, without armor
- 330902, ¼ -28 UNF-2A, with armor
- 330903, M8x1 thread, without armor
- 330904, M8x1 thread, with armor
- 330905, M10x1 thread, without armor
- 330908, 3/8-24 UNF-2A, without armor
- 330909, 3/8-24 UNF 2A, with armor
- 330910, M10x1 thread, with armor



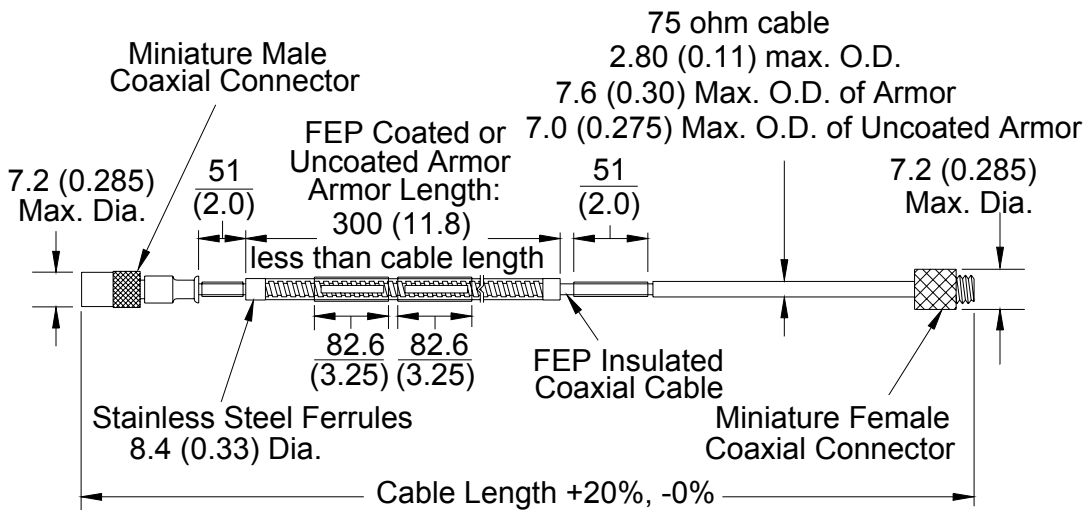
**Figure 19 Installed Connector Protectors**



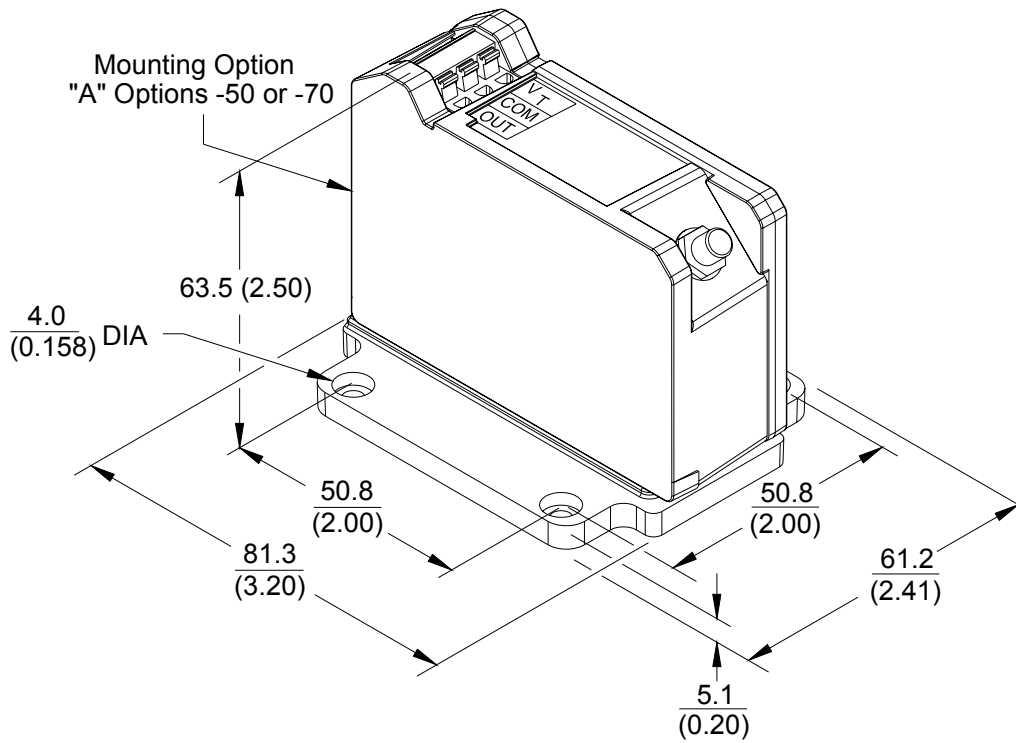
**Figure 20 3300 NSv™ Proximity Probes, Reverse Mount**

330906, 3/8-24 UNF-2A threads

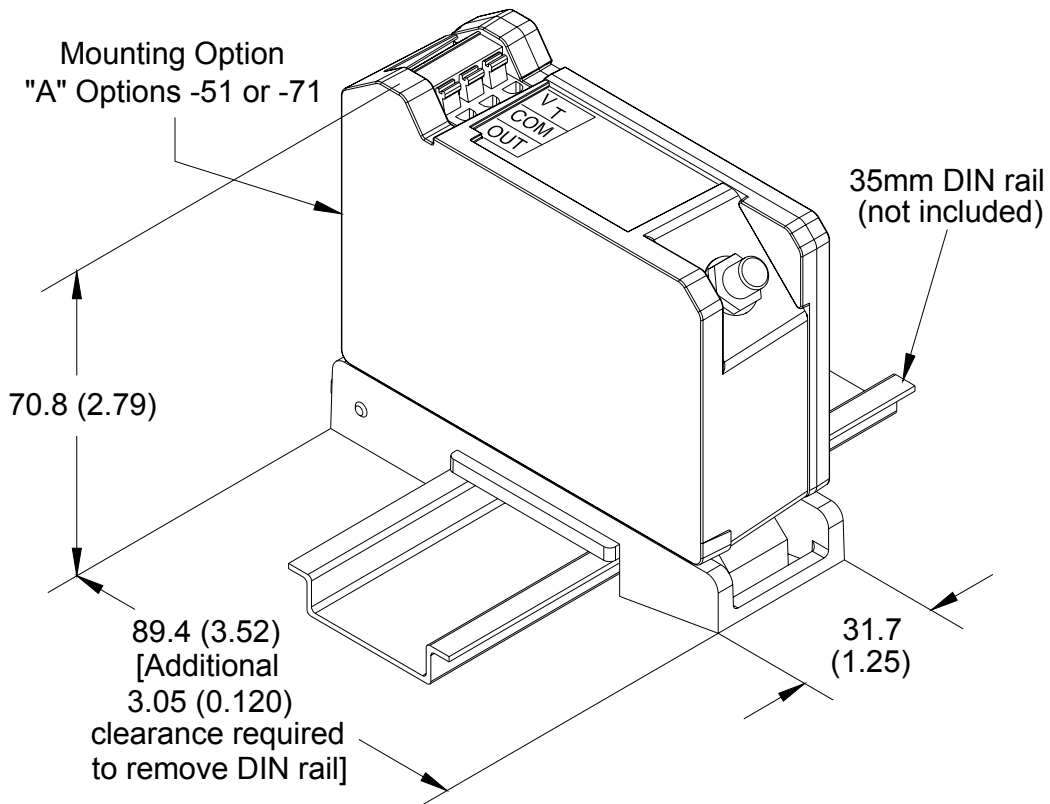
330907, M10x1 threads



**Figure 21 330930, 3300 NSv™ Extension Cable**



**Figure 22 Panel Mount 3300 XL NSv™ Proximito® Sensor**



**Figure 23 DIN Mount 3300 XL NSv™ Proximito® Sensor**

**Notes:**

All dimensions on figures are in millimetres (inches) unless otherwise noted.

Standard mount  $\frac{1}{4}$ -28 UNF thread probes are supplied with  $\frac{7}{16}$  inch lock nut and  $\frac{7}{32}$  wrench flats.

Standard mount M8x1 thread probes are supplied with 13 mm lock nut and 7 mm wrench flats.

Standard mount  $\frac{3}{8}$ -24 UNF thread probes are supplied with  $\frac{9}{16}$  inch lock nut and  $\frac{5}{16}$  wrench flats.

Standard mount M10x1 thread probes are supplied with 17 mm lock nut and 8 mm wrench flats.

Reverse mount probes are not available with armor or connector protector options.

Letters inside quotation marks on figures refer to probe ordering options.

Stainless steel armor is supplied with or without FEP outer jacket.

FEP jacket is standard on all non-armored probes.

© 2001 Bently Nevada LLC