

FLUKE®

Calibration

molbox™ RFM™
**Reference
Flow Monitor**
(Ver 1.20 and Higher)
Operation and Maintenance Manual

⚠ Warning

High pressure liquids and gases are potentially hazardous. Energy stored in these liquids and gases can be released unexpectedly and with extreme force. High pressure systems should be assembled and operated only by personnel who have been instructed in proper safety practices.

© 2010 **Fluke Calibration** All rights reserved.

Information in this document is subject to change without notice. No part of this document may be reproduced or transmitted in any form or by any means, electronic or mechanical, for any purpose, without the express written permission of **Fluke Calibration**, 4765 East Beautiful Lane, Phoenix, Arizona 85044-5318 USA.

Fluke Calibration makes sincere efforts to ensure the accuracy and quality of its published materials; however, no warranty, expressed or implied, is provided. **Fluke Calibration** disclaims any responsibility or liability for any direct or indirect damages resulting from the use of the information in this manual or products described in it. Mention of any product or brand does not constitute an endorsement by **Fluke Calibration** of that product or brand. This manual was originally composed in English and was subsequently translated into other languages. The fidelity of the translation cannot be guaranteed. In case of conflict between the English version and other language versions, the English version predominates.

Products described in this manual are manufactured under international patents and one or more of the following U.S. patents: 5,142,483, 5,257,640, 5,331,838, 5,445,035. Other U.S. and international patents pending.

Fluke Calibration, **FCAL**, **DH**, **DHI**, molbox, molbox RFM , molbox1, molbox1+, molbloc, molbloc-L, molbloc-S, molstic, COMPASS, CalTool are trademarks, registered and otherwise, of **Fluke Corporation**.

LabVIEW is registered trademark of National Instruments Corporation.
Swagelok is a registered trademark of the Swagelok Company.

Document No. 3152156
101115
Printed in the USA.

Table Of Contents

Table Of Contents	III
Tables	VII
Figures	IX
About This Manual.....	XI
1. Introduction	1
1.1 Product Overview	1
1.1.1 molbloc Flow Elements	1
1.1.1.1 molbloc-L Flow Element	1
1.1.1.2 molbloc-S Flow Element	2
1.2 Specifications	2
1.2.1 General Specifications	2
1.2.2 Reference Pressure Transducer (RPT) Specifications	3
1.2.2.1 Upstream and Downstream RPTs.....	3
1.2.2.2 Differential RPT (Microrange Option)	3
1.2.3 Temperature Measurement Specifications.....	4
1.2.4 Flow Measurement Specifications.....	4
1.2.4.1 molbloc-L Flow Measurement Specifications, Model Ranges 1E1-L thru 3E4-L.....	4
1.2.4.1.1 molbloc-L FLOW MEASUREMENT SPECIFICATIONS, MICRORANGE OPTION	5
1.2.4.1.2 molbloc-L Pressure Dependent Calibration Types.....	6
1.2.4.1.3 molbloc-L Ranges with Low Pressure Calibrations.....	7
1.2.4.1.4 molbloc-L Ranges with High Pressure Calibrations.....	8
1.2.4.1.5 molbloc-L DIMENSIONS	9
1.2.4.2 molbloc-S.....	10
1.2.4.2.1 molbloc-S Pressure Dependent Calibration Types	10
1.2.4.2.2 molbloc-S Ranges.....	11
1.2.4.2.3 molbloc-S Dimensions	22
1.2.5 Front and Rear Panels	24
1.2.5.1 Front Panel	24
1.2.5.2 Rear Panel.....	24
2. Installation.....	25
2.1 UNPACKING AND INSPECTION	25
2.1.1 Removing From Packaging	25
2.1.2 Inspecting Contents.....	25
2.2 Site Requirements.....	25
2.3 Initial setup	26
2.3.1 Preparing for Operation.....	26
2.3.2 Power Connection	26
2.3.3 molbox RFM to molbloc Connection	27
2.3.4 GAS Supply And Flowpath Connections.....	27
2.3.5 Vacuum Supply (molbloc-S only).....	28
2.3.6 Communications Connections.....	28
2.4 Power UP and Verification.....	29
2.4.1 Power UP	29
2.4.2 Check Proper Pressure Measurement Operation	29
2.4.3 Check Proper Temperature Measurement Operation.....	29
2.4.4 Leak Check.....	30
2.4.5 Check/Set Security Level.....	30
2.5 Additional Precautions to Take Before Making Flow Measurements.....	30
2.6 Short Term Storage.....	31

3.	Operation	33
3.1	General Operating Principles	33
3.1.1	molbloc-L and molbloc-S operation	33
3.1.2	molbloc-S BPR Limits.....	33
3.1.3	Flow Ready/Not Ready Indication	34
3.1.3.1	molbloc-L Operation.....	35
3.1.3.2	molbloc-S Operation	35
3.1.4	Soft [On/Off] Key.....	35
3.1.5	Microrange option (Optional).....	36
3.1.6	Reference pressure transducer (RPT) overpressure.....	37
3.1.6.1	Upstream and Downstream Absolute RPTS	37
3.1.6.2	Differential RPT, Microrange Option.....	37
3.2	Main Run Screen	37
3.2.1	molbloc-L Operation	38
3.2.2	molbloc-S Operation.....	39
3.3	Manual Operation	40
3.3.1	Keypad Layout and Protocol	40
3.3.2	Sounds.....	41
3.3.3	Soft [On/Off] Key.....	41
3.3.4	Direct Function Keys Summary	41
3.4	Direct Function Keys.....	42
3.4.1	[K].....	42
3.4.2	[GAS].....	44
3.4.2.1	molbloc-L Operation.....	45
3.4.2.2	molbloc-S Operation	46
3.4.3	[UNIT].....	48
3.4.3.1	Mass Flow vs. Volume Flow.....	49
3.4.3.2	Volumetrically Based Mass Flow Units.....	50
3.4.3.3	Volumetrically Based Mass Flow Units at Various Reference Temperatures (UXXX)	51
3.4.3.4	Volume Flow Units (vfm)	51
3.4.3.5	Customizing FLOW Units Available Under The UNIT Function	52
3.4.4	[TARE].....	53
3.4.4.1	<1Tare>	54
3.4.4.1.1	molbloc-L OPERATION	54
3.4.4.1.2	molbloc-S Operation	57
3.4.4.2	<2Purge>	58
3.4.4.3	<3Leak Check>	60
3.4.4.3.1	Leak Check molbox.....	61
3.4.4.3.2	Leak Check System	63
3.4.4.4	<4AutoZ>	67
3.4.4.4.1	Edit AutoZ.....	69
3.4.4.4.2	Run AutoZ.....	70
3.4.4.5	<5BPR> (molbloc-S Operation only)	72
3.4.5	[P&T] (Pressure and Temperature)	73
3.4.6	[DISPLAY]	75
3.4.6.1	<1Rate>	76
3.4.6.2	<2AVG> (AVERAGE).....	77
3.4.6.3	<3 Hi/Lo>	78
3.4.6.4	<4TOTAL> (TOTALIZER)	78
3.4.6.5	<5UNIT>	80
3.4.6.6	<6DEV>	81
3.4.6.7	<7FREEZE>.....	82
3.4.6.8	<8CLEAN>.....	82
3.4.7	[MICRO] (Optional).....	83
3.4.8	[molbloc].....	84
3.4.8.1	molbloc-L and molbloc-S size and Range Designations	85
3.4.9	[RES].....	86
3.5	[SETUP].....	86
3.5.1	<1FLOWU>	87
3.5.2	<2PRESU>	87
3.5.3	<3TEMPU>.....	88
3.5.4	<4molbloc>.....	88
3.5.5	<5stab>	89
3.5.6	<6ADJ>.....	90

3.6	[SPECIAL]	91
3.6.1	<1reset>	92
3.6.1.1	<1sets>	92
3.6.1.2	<2units>	93
3.6.1.3	<3com>	93
3.6.1.4	<4cal>	93
3.6.1.5	<5all>	94
3.6.2	<2level>	94
3.6.2.1	Security Levels	95
3.6.3	<3UL>	98
3.6.3.1	Upper Limit Alarm and Sequence	99
3.6.4	<4cal>	99
3.6.5	<5prefs>	99
3.6.5.1	<1ScrSVR>	100
3.6.5.2	<2Sound>	100
3.6.5.3	<3Time>	100
3.6.5.4	<4ID>	101
3.6.5.5	<5log>	102
3.6.6	<6remote>	102
3.6.6.1	COM1 and COM2	103
3.6.6.2	IEEE-488	103
3.6.6.3	RS232 Self-Test	103
3.6.7	<7Micro>	104
3.6.8	<8Head>	105
3.6.9	<9BPR>	106
4.	Remote Operation	111
4.1	Overview	111
4.2	Interfacing	111
4.2.1	RS232 Interface	111
4.2.1.1	COM1	112
4.2.1.2	COM2	112
4.2.2	IEEE-488 (GPIB)	113
4.3	Commands	113
4.3.1	Command Syntax	113
4.3.2	COMMAND summary	114
4.3.3	Error Messages	116
4.3.4	Command Descriptions	117
4.3.4.1	IEEE Std. 488.2 Common and Status Commands	117
4.3.4.2	MOLBOX rfm commands	121
4.4	Status System	147
4.4.1	Status Reporting System	147
4.4.1.1	Status Byte Register	147
4.4.1.2	Standard Event Register	149
5.	Maintenance, Adjustments And Calibration	151
5.1	Product Overview	151
5.2	Calibration of Reference Pressure Transducers (RPTs)	152
5.2.1	Principle	152
5.2.1.1	PA and PM Coefficients	153
5.2.2	Equipment Required	153
5.2.2.1	upstream and downstream ABSolute RPTs	153
5.2.2.2	Differential (microrange) RPT	154
5.2.3	Set-Up and Preparation	154
5.2.3.1	UPSTREAM AND DOWNSTREAM Absolute RPTS	154
5.2.3.2	MICRORANGE Differential RPT	155
5.2.4	Viewing and editing RPT READINGS AND Calibration Information	155
5.2.4.1	Viewing RPT outputs	156
5.2.4.2	Viewing and Editing rpt PA, PM and Calibration date	158
5.2.5	RPT Calibration/Adjustment Procedure Without Using CALTOOL for RPTs Software	159
5.3	OHMIC Measurement System Verification	160
5.3.1	OHMIC Measurement System Calibration/Adjustment Procedure	162

5.4	Reloading Embedded Software Into molbox RFM Flash Memory	163
5.5	RELOADING MOLBLOC EEPROM FILE.....	163
5.6	Overhaul.....	163
5.6.1	Internal View.....	164
5.6.1.1	Upstream absolute RPT.....	165
5.6.1.2	Downstream absolute RPT	165
5.6.1.3	Differential microrange RPT (optional)	165
5.6.1.4	Display	165
5.6.1.5	Power Supply	165
5.6.1.6	Micro Board.....	165
5.6.1.7	Valving Module.....	165
5.6.1.8	Main Board.....	166
5.6.1.9	Cooling fan.....	166
6.	Troubleshooting	167
6.1	OVERVIEW	167
7.	Appendix	173
7.1	CONVERSION OF NUMERICAL VALUES.....	173
7.1.1	PRESSURE	173
7.1.2	Temperature	173
7.1.3	Flow	174
7.2	Limited Warranty and Limitation of Liability.....	177
8.	Glossary	179

Tables

Table 1. molbloc-L Pressure Dependent Calibration Types.....	6
Table 2. molbloc-L Ranges with Low Pressure and Downstream Calibrations.....	7
Table 3. molbloc-L Ranges with High Pressure Calibrations	8
Table 4: molbloc-S Calibration Types	11
Table 5: N ₂ . molbloc-S Flow in Nitrogen at Various molbloc Upstream Pressures	12
Table 6: Ar. molbloc-S Flow in Argon at Various molbloc Upstream Pressures	12
Table 7: He. molbloc-S Flow in Helium at Various molbloc Upstream Pressures	13
Table 8: SF ₆ . molbloc-S Flow in Sulfur Hexafluoride at Various molbloc Upstream Pressures	13
Table 9: Xe. molbloc-S Flow in Xenon at Various molbloc Upstream Pressures	14
Table 10: C ₄ H ₁₀ . molbloc-S Flow in Butane at Various molbloc Upstream Pressures.....	14
Table 11: C ₂ H ₆ . molbloc-S Flow in Ethane at Various molbloc Upstream Pressures.....	15
Table 12: C ₂ H ₄ . molbloc-S Flow in Ethylene at Various molbloc Upstream Pressures	15
Table 13: H ₂ . molbloc-S Flow in Hydrogen at Various molbloc Upstream Pressures	16
Table 14: CH ₄ . molbloc-S Flow in Methane at Various molbloc Upstream Pressures	16
Table 15: C ₃ H ₈ . molbloc-S Flow in Propane at Various molbloc Upstream Pressures	17
Table 16: CF ₄ . molbloc-S Flow in Carbon Tetrafluoride at Various molbloc Upstream Pressures	17
Table 17: C ₂ F ₆ . molbloc-S Flow in Hexafluoroethene at Various molbloc Upstream Pressures	18
Table 18: CHF ₃ . molbloc-S Flow in Trifluoromethane at Various molbloc Upstream Pressures	18
Table 19: Air. molbloc-S Flow in Air at Various molbloc Upstream Pressures	19
Table 20: CO ₂ . molbloc-S Flow in Carbon Dioxide at Various molbloc Upstream Pressures	19
Table 21: CO. molbloc-S Flow in Carbon Monoxide at Various molbloc Upstream Pressures	20
Table 22: N ₂ O. molbloc-S Flow in Nitrous Oxide at Various molbloc Upstream Pressures	20
Table 23: C ₄ F ₈ . molbloc-S Flow in Octafluorocyclobutane ₁ at Various molbloc Upstream Pressures.....	21
Table 24: O ₂ . molbloc-S Flow in Oxygen at Various molbloc Upstream Pressures	21
Table 25. molbox RFM Parts List.....	25
Table 26: Minimum molbloc-S Critical Flow (slm) in Nitrogen at Various molbloc-S Downstream Pressures	34
Table 27. Summary of molbox RFM Direct Function Key Operations	42
Table 28. Available molbloc-L Gases.....	45
Table 29. Available Flow Units	52
Table 30. Flow Units and Corresponding Total Mass or Volume Units.....	80
Table 31. molbloc-L Size and Nominal Range Designations	85
Table 32. molbloc-S Size Designation and Pressure to Flow Conversion Ratio (K _F).....	86
Table 33. Pressure Units of Measure Available	88
Table 34. Security Levels - Functions NOT Executed Per Function/Level	96
Table 35. Security Levels - Functions NOT Executed Per Function/Level (Continued).....	97
Table 36. COM1 and COM2 Available Settings	103
Table 37. COM1 DB-9F Pin Designation	112
Table 38. COM2 DB-9M Pin Designation.....	113
Table 39. Command Summary	114
Table 40. Error Messages	116
Table 41. Status Byte Register.....	147
Table 42. Standard Event Register	149
Table 43. Troubleshooting Checklist.....	167

Table 44. Pressure Unit Conversions	173
Table 45. Temperature Unit Conversion	173
Table 46. Conversions From kg/s To sccm At 0 °C For Various Gases.....	174
Table 47. Conversions From sccm At 0 °C To Other Volumetrically Based Flow Units	174
Table 48. Conversions From Volumetrically Based Flow Units At 0 °C To Corresponding Units At Another Temperature (uxxx)	175
Table 49. Conversions From kg/s To mole/s For Various Gases	175
Table 50. Conversion From mole/s To pccm	176
Table 51. Conversion From sccm At 0 °C to Volume Flow Units At Another Pressure And Temperature.....	176
Table 52. Fluke Calibration Authorized Service Providers	178

Figures

Figure 1. molbloc-L Upstream End Flange with Integrated Filter	2
Figure 2. molbox RFM Front Panel	24
Figure 3. molbox RFM Rear Panel.....	24
Figure 4. molbox RFM Internal Pneumatic Schematic –	36
Figure 5. Keypad Layout	40
Figure 6. molbox RFM Internal Pneumatic Schematic – TARING, UPSTREAM molbloc-L OPERATION	55
Figure 7. molbox RFM Internal Pneumatic Schematic – TARING molbloc-S OPERATION.....	58
Figure 8. molbox RFM Internal Pneumatic Schematic – PURGING	59
Figure 9. molbox RFM Internal Pneumatic Schematic – LEAK CHECK molbox	62
Figure 10. molbox RFM Internal Pneumatic Schematic – SYSTEM LEAK CHECK – CHECKING OFFSET AND STABILITY molbloc-L operation	64
Figure 11. molbox RFM Internal Pneumatic Schematic – SYSTEM LEAK CHECK – CHECKING OFFSET AND STABILITY molbloc-S operation.....	66
Figure 12. molbox RFM Internal Pneumatic Schematic – molbloc-S OPERATION, BPR ON	107
Figure 13. molbox RFM Internal Pneumatic Schematic – molbloc-S OPERATION, BPR OFF.....	107
Figure 14. Status Byte Register	148
Figure 15. molbox RFM Internal Pneumatic Schematic – RUN UPSTREAM OR DOWNSTREAM ABSOLUTE RPT CALIBRATION	157
Figure 16. molbox RFM Internal Pneumatic Schematic – RUN MICRORANGE DIFFERENTIAL RPT CALIBRATION.....	158
Figure 17. molbox RFM Internal View.....	164
Figure 18. molbox RFM Valving Assembly Schematic	166

Notes

About This Manual

This manual provides the user with the information necessary to operate a molbox RFM, Reference Flow Monitor. It also includes a great deal of additional information provided to help you optimize molbox RFM use and take full advantage of its many features and functions.

Before using the manual, take a moment to familiarize yourself with the Table of Contents structure: All first time molbox RFM users should read Section 2. Section 3 provides a comprehensive description of general molbox RFM operating principles. Section 4 is for remote operation from an external computer. Section 5 provides maintenance and calibration information. Section 6 is a quick troubleshooting guide. Use it to troubleshoot unexpected molbox RFM behavior based on the symptoms of that behavior.

Certain words and expressions have specific meaning as they pertain to molbox RFM. Section 8 is useful as a quick reference for exact definition of specific words and expressions as they are used in this manual.

Note

For those of you who “don’t read manuals”, go directly to section 2.3, initial setup, to set up your molbox RFM. Then go to section 2.4, power up and verification. This will get you running quickly with minimal risk of causing damage to yourself or your molbox RFM. THEN... when you have questions or start to wonder about all the great features you might be missing, get into the manual!

Manual Conventions

Caution

“Caution” is used in throughout the manual to identify conditions or actions that could cause harm to the molbox RFM or to the devices that are connected to the molbox RFM.

Warning

“Warning” is used in throughout the manual to identify actions that could pose a hazard to the user of the molbox RFM.

Note

“Note” is used throughout the manual to identify operating and applications advice and additional explanations.

[] Indicates direct function keys (e.g., [RANGE]).

<> Indicates molbox1+ screen displays (e.g., <1yes>).

Notes

1. Introduction

1.1 Product Overview

molbox RFM is a support unit for making low mass flow measurements using molbloc mass flow elements. molbox RFM reads calibration data off the molbloc EEPROM and measures molbloc upstream and downstream pressure using built-in high accuracy Reference Pressure Transducers (RPTs). An ohmic measurement system reads the resistance of the molbloc platinum resistance thermometers from which molbloc temperature is calculated. Using the molbloc calibration data, pressures, temperature and gas properties stored in memory, the flow rate of the gas flowing through the molbloc is calculated. For molbloc-L laminar flow element model ranges 1E1-L to 3E4-L a microrange option is available to increase resolution and accuracy below 10 % FS of the flow range. For the molbloc-L model range 1E5-L the microrange option is required to achieve the stated uncertainty due to the very low differential pressure of this range. The microrange option has no function in relation to the molbloc-S sonic flow elements.

Internal molbox RFM valving supports on-board PRESSURE TRANSDUCER TARING, LEAK TESTING and SELF PROTECTION functions as well as a gas purge routine.

molbox RFM provides a local user interface via a front panel key pad and display and includes advanced on-board functions. Remote communication capability is supported with RS232 and IEEE-488 interfaces.

molbox RFM is intended for applications in which a highly compact presentation, high range ability and lower cost are the primary considerations. A second model, molbox1+, is available for applications where higher accuracy is the most important requirement.

1.1.1 molbloc Flow Elements

Two different types of molblocs may be used with molbox RFM; molbloc-L (laminar) and molbloc-S (sonic). The molbox RFM version 1.20 or later maintains support for older molblocs but also supports operation with new or upgraded molblocs that have the updated data structure to take advantage of molbox1+ features.

1.1.1.1 molbloc-L Flow Element

molbloc-L is the original molbloc laminar flow element. molbloc-L covers the lower portion of the molbloc/molbox system flow range. The key molbloc-L measurement is the differential pressure across the element, which is roughly proportional to the mass flow rate through it. molbloc-L elements are calibrated to be used at an absolute pressure that remains nearly constant, while the differential pressure varies with flow rate. Different operating pressure options and their effect on molbloc flow range are described in Section 1.2.4.1.2.

In addition to the new data structure and modelization methods that became available for molblocs with the introduction of molbox1+, all molbloc-L elements of range 1E1-L to 3E4-L produced or upgraded after the release of molbox1+ are equipped standard with an upstream ¼" VCR flange, or flowpath connection, that has an integrated sintered metal filter. This filter is intended to be a last defense against particulate contamination of the molbloc-L internal flowpath which can affect molbloc-L measurements. Every effort should still be made to supply clean dry gas to the molbloc to ensure its measurement performance and long-term stability. molblocs that have the integrated upstream filter are recognizable by the visible filter element as shown below.



Figure 1. molbloc-L Upstream End Flange with Integrated Filter

New molbloc-L elements produced with molbox1+ calibration data structure, premium calibration options, and integrated filter hardware can be identified by having a serial number of 6000 or higher. Most older molbloc-L elements are eligible for upgrade to this hardware/version by Fluke Calibration.

1.1.1.2 molbloc-S Flow Element

molbloc-S elements use critical (sonic) flow venturi nozzle technology to measure flows, which overlap with the higher molbloc-L ranges and extend the high end of the molbloc/molbox RFM system flow range. The mass flow rate through a molbloc-S element is roughly proportional to the upstream absolute pressure when the flow is “choked”, so the molbloc-S operating pressure can vary widely as the mass flow rate is changed throughout the flow range. The limits of molbloc-S operating pressure and flow ranges are defined by the molbloc-S calibration type, described in Section 1.2.4.2.2.

New calibration data structure and premium calibration options for molbloc-S were also introduced along with molbox1+. molbloc-S elements produced with this support will have serial number of 4000 or higher. Older molbloc-S elements are eligible for upgrade to this version format by Fluke Calibration.

1.2 Specifications

1.2.1 General Specifications

Power Requirements	85 to 264 VAC, 47 to 440 Hz, 18 VA max. consumption
Fuse	1A/250V, slow blow, 5x20mm, NSN: 5920008930491
Operating Temperature Range	15 to 35 °C
Storage Temperature Range	-20 to 70 °C
Vibration	Meets MIL-T-28800D
Weight	2.55 kg (5.6 lb) max.
Dimensions	8 cm H x 22.5 cm W x 20 cm D (3.1 in. x 8.9 in. x 7.9 in.) approx.

Microprocessor	Motorola 68302, 16 MHz
Communication Ports	RS232 (COM1), RS232 (COM2), IEEE-488
Reference Pressure Transducers (RPTs)	Standard: 2 x 600 kPa (87 psia) calibrated range piezoresistive silicon Microrange option: 12.5 kPa (1.8 psid) piezoresistive silicon
Ohmic Measurement System	Resolution: 0.004 Ω Accuracy: $\pm 0.04 \Omega$ Accuracy of 100 and 110 Ω reference resistors: $\pm 0.01 \%$ Stability of 100 and 110 Ω reference resistors: $\pm 0.005 \%$ per three years
Gases Supported	molbloc-L and molbloc-S Nitrogen (N ₂), dry Air, humid Air (molbloc-S only), Argon (Ar), Butane (Butn), Carbon Monoxide (CO), Helium (He), Oxygen (O ₂), Carbon Dioxide (CO ₂), Carbon Tetrafluoride (CF ₄), Octofluorocyclobutane (C ₄ F ₈), Ethane (C ₂ H ₆), Ethylene (C ₂ H ₄), Fluoroform (CHF ₃), Hexafluoroethane (C ₂ F ₆), Hydrogen (H ₂), Methane (CH ₄), Nitrous Oxide (N ₂ O), Propane (C ₃ H ₈), Sulfur Hexafluoride (SF ₆), Xenon (Xe)
Pressure Connections	Quick connectors equivalent to Swagelok QM Series (-QM2-B200)
Pressure Limits	Maximum working pressure 600 kPa absolute (87 psia) Maximum pressure without damage 800 kPa absolute (115 psia) NOTE: The microrange option includes a 12.5 kPa (1.8 psi) differential RPT which may be damaged by differential pressure greater than 100 kPa (15 psi).
Flow Ranges	See Sections 1.2.4.1.3, 1.2.4.1.4 and 1.2.4.2.1
CE Conformance	Available. Must be specified.

1.2.2 Reference Pressure Transducer (RPT) Specifications

1.2.2.1 Upstream and Downstream RPTs

Type	Piezoresistive silicon
Range	0 to 600 kPa absolute (0 to 87 psia)
Resolution	6.0 Pa (0.0009 psi)
Repeatability	$\pm 0.01 \%$ FS
Accuracy	Absolute measurements: $\pm 0.06 \%$ FS for one year Differential measurements: $\pm (20 \text{ Pa} + 0.05 \% \Delta P)$. Taring sequence eliminates zero error on measurement of difference between the two RPTs.

1.2.2.2 Differential RPT (Microrange Option)

Type	Piezoresistive silicon
Range	0 to 12.5 kPa differential (0 to 1.8 psid)
Resolution	0.14 Pa (0.00002 psi)
Repeatability	$\pm 0.01 \%$ FS
Accuracy	$\pm (0.14\% \text{ of reading} + 0.01\% \text{ F.S.})$ for one year. Taring sequence eliminates zero error.

1.2.3 Temperature Measurement Specifications

Specifications are for molbloc mounted Platinum Resistance Thermometers (PRT) combined with molbox RFM resistance measurement system and temperature calculation.

Range	0 to 40 °C
Accuracy	± 0.05 °C
Resolution	0.01 °C

The molbox RFM internal resistance measurement system is automatically calibrated using reference 100 and 110 Ω (± 0.01 %) resistors (see Section 5.3).

1.2.4 Flow Measurement Specifications

molbox RFM measures the flow through molbloc flow elements. There are two different types of molblobs, molbloc-L (laminar) (see Section 1.1.1.1) and molbloc-S (sonic) (see Section 1.1.1.2). Flow measurement specifications, calibration types, ranges and dimensions are detailed separately for each molbloc type in Section 1.2.4.1 and 1.2.4.2.

All flow measurement uncertainties are valid only for measurements in a gas for which the molbloc is calibrated, and within the range of pressures for which the calibration is specified.

1.2.4.1 molbloc-L Flow Measurement Specifications, Model Ranges 1E1-L thru 3E4-L

The flow range, useable operating pressure and absolute and differential pressure associated with molbloc-L operation depend on the molbloc used and its pressure-dependent calibration options (see Section 1.2.4.1.2). Use of molbloc-L model range 1E5-L is only recommended for use with the microrange option (see Section 1.2.4.1.1).

Measurement Update Rate	1 second
Range	0 to molbloc full scale depending on gas and molbloc pressure dependent calibration type (see Section 1.2.4.1.2).
Resolution	0.01 % FS
Linearity	± 0.23 % of reading from 10 to 100 % FS, ± 0.023 % FS under 10 % FS
Repeatability	± 0.1 of reading from 10 to 100 % FS, ± 0.01 % FS under 10 % FS
Precision¹	± 0.25 % of reading from 10 to 100 % FS, ± 0.025 % FS under 10 % FS
Stability² (1 year)	± 0.15 % of reading from 10 to 100 % FS, ± 0.015 % FS under 10 % FS
Measurement Uncertainty³ (1 year, N ₂ and any molbox RFM supported gas for which the molbloc in use is calibrated)	± 0.5 % of reading from 10 to 100 % FS, ± 0.05 % FS under 10 % FS

1 Precision: Combined linearity, hysteresis, repeatability.

2 Stability: Maximum change in zero and span over specified time period for typical molbox RFM and molbloc used under typical conditions. As stability can only be predicted, stability for a specific molbox RFM should be established from experience.

3 Measurement Uncertainty: Maximum deviation of the molbox RFM flow indication from the true value of the flow through the molbloc including precision, stability and **Fluke** calibration standard uncertainty. Measurement uncertainty specifications for molblobs are valid only for gases with which the molbloc has been calibrated. All molblobs are calibrated for N₂. Calibrations with other gases are optional. **Fluke** calibration capability is not maintained at all times for all gases on all molbloc designations. Check for availability before ordering.

1.2.4.1.1 molbloc-L FLOW MEASUREMENT SPECIFICATIONS, MICRORANGE OPTION

The microrange option (see Section 1.2.2.2) improves molbloc-L flow measurement specifications below 10 % FS of the molbloc model ranges 1E1-L thru 3E4-L, and is required to achieve the measurement specification of molbloc model range 1E5-L. With the microrange option, the affected measurement specifications become:

Molbloc-L (Ranges 1E1-L Thru 3E4-L)

Update Rate	1 second
Range	0 to molbloc full scale depending on gas and molbloc pressure dependent calibration type (see molbloc-L tables)
Resolution	0.01% FS, 0.001% FS under 10% FS
Linearity	±0.23% of reading from 1 to 100% FS, ±0.0023% FS under 1% FS
Repeatability	±0.1% of reading from 1 to 100% FS, ±0.001% FS under 1% FS
Precision¹	±0.25% of reading from 1 to 100% FS, ±0.0025% FS under 1% FS
Stability² (1 year)	±0.15% of reading from 1 to 100% FS, ±0.0015% FS under 1% FS
Measurement Uncertainty³	±0.5% of reading from 1 to 100% FS, ±0.005% FS under 1% FS

molbloc-L (Ranges 1E5-L Only)

Update Rate	1 second
Range	0 to molbloc full scale depending on gas and molbloc pressure dependent calibration type (see molbloc-L tables)
Resolution	0.01% FS
Linearity	± 0.25% of reading from 5 to 100% FS, ± 0.0125% FS under 5% FS
Repeatability	± 0.2% of reading from 5 to 100% FS, ± 0.01% FS under 5% FS
Precision¹	± 0.32% of reading from 5 to 100% FS, ± 0.016% FS under 5% FS
Stability² (1 year)	± 0.2% of reading from 5 to 100% FS, ± 0.01% FS under 5% FS
Measurement Uncertainty³	± 0.5% of reading from 5 to 100% FS, ± 0.025% FS under 5% FS

1 Precision: Combined linearity, hysteresis, repeatability.

2 Stability: Maximum change in zero and span over specified time period for typical molbox RFM and molbloc used under typical conditions. As stability can only be predicted, stability for a specific molbox RFM should be established from experience.

3 **Measurement Uncertainty:** Maximum deviation of the molbox RFM flow indication from the true value of the flow through the molbloc including precision, stability and **Fluke** calibration standard uncertainty. Measurement uncertainty specifications for molblocs are valid only for gases with which the molbloc has been calibrated. All molblocs are calibrated for N₂. Calibrations with other gases are optional. **Fluke** calibration capability is not maintained at all times for all gases on all molbloc designations. Check for availability before ordering.

1.2.4.1.2 molbloc-L Pressure Dependent Calibration Types

Note

See your molbloc's Calibration Report to determine the calibration type of the molbloc you are using.

Different pressure dependent calibration options for molbloc-L elements determine the range of operating pressures over which a molbloc can be used within its mass flow measurement specifications. The calibration option also affects the molbloc flow range and the differential pressure associated with the flow range.

Measurement uncertainty (accuracy) specifications for molbloc-L are valid only for gases with which the molbloc has been calibrated. All molbloc-L elements are calibrated for N₂. Calibrations with other gases are optional. **Fluke** calibration capability is not maintained at all times for all gases on all molbloc designations. Check for availability before ordering calibrations.

The molbloc-L pressure dependent calibration types are summarized in Table 1.

Table 1. molbloc-L Pressure Dependent Calibration Types

CALIBRATION TYPE (CALIBRATION NAME)	OPERATING PRESSURE	NOMINAL DIFFERENTIAL PRESSURE AT MAX. FLOW	
		1E5 MOLBLOC	ALL OTHER MOLBLOCS
Low pressure (LOP)	200 to 325 kPa absolute (29 to 48 psia) upstream of molbloc	5 kPa (.725 psi)	50 kPa (7.5 psi)
High pressure (HIP)	325 to 525 kPa absolute (48 to 76 psia) upstream of molbloc	Not available	50 kPa (7.5 psi)
Downstream (DOWN)	Atmospheric pressure downstream of molbloc. 85 to 105 kPa (12 to15 psia).	12.5 kPa (1.8 psi)	80 kPa (12 psi)

Note

Differential pressure values are nominal and may vary by up to 15 % with the actual molbloc used.

1.2.4.1.3 molbloc-L Ranges with Low Pressure Calibrations

Table 2. molbloc-L Ranges with Low Pressure and Downstream Calibrations

GASES			molbloc-L SIZE AND FULL SCALE FLOW (sccm @ 0 °C)									
			SIZE 1E1	SIZE 5E1	SIZE 1E2	SIZE 2E2	SIZE 5E2	SIZE 1E3	SIZE 5E3	SIZE 1E4	SIZE 3E4	SIZE 1E5
INERT	Nitrogen	N ₂	10	50	100	200	500	1,000	5,000	10,000	30,000	100,000
	Argon	Ar	10	50	100	200	500	1,000	5,000	10,000	30,000	80,000
	Helium	He	10	50	100	200	500	1,000	5,000	10,000	30,000	100,000
	Sulfur Hexafluoride	SF ₆	10	50	100	200	500	1,000	2,000 500	6,000 1,000	6,000 4,000	---
	Xenon	XE	10	40	80	150	400	800	3,500 500	8,000	11,000 3,000	30,000 20,000
FLAMMABLE	Butane	C ₄ H ₁₀	20	100	130 30	270 50	670 140	2,300	2,200 1,400	7,000 3,000	---	---
	Ethane	C ₂ H ₆	20	100	200	400	1,000	2,000	6,000 1,000	18,000 2,000	18,000 6,000	60,000 50,000
	Ethylene	C ₂ H ₄	16	80	160	320	800	1 600	7,000 1,000	16,000	20,000 5,000	70,000 40,000
	Hydrogen	H ₂	20	100	200	400	1,000	2,000	10,000	20,000	60,000	200,000
	Methane	CH ₄	16	80	160	320	800	1 600	8,000	16,000	40,000 5,000	120,000 40,000
	Propane	C ₃ H ₈	20	100	200	400	1,000	2,000	3,000 1,000	10,000 2,000	10,000 7,000	---
FLUORO-CARBONS	Carbon Tetrafluoride	CF ₄	10	50	100	200	500	1,000	4,000 600	10,000	12,000 3,000	36,000 25,000
	Hexafluorethene	C ₂ F ₆	10	50	100	200	500	1,000	2,000 600	6,000 1,200	6,000 4,000	---
	Trifluoromethane	CHF ₃	10	50	100	200	500	1,000	4,000 600	10,000	12,000 4,000	38,000 30,000
OTHER	Air	Air	10	50	100	200	500	1,000	5,000	10,000	30,000	100,000
	Carbon Dioxide	CO ₂	10	50	100	200	500	1,000	5,000	10,000	20,000 4,000	60,000 30,000
	Carbon Monoxide	CO	10	50	100	200	500	1,000	5,000	10,000	30,000	100,000
	Nitrous Oxide	N ₂ O	10	50	100	200	500	1,000	5,000	10,000	20,000 4,000	60,000 30,000
	Octafluorocyclobutane ¹	C ₄ F ₈	15	60 9	65 17	130 34	330 85	1,100 175	1,050 840	3,400 1,700	---	---
	Oxygen	O ₂	10	50	100	200	500	1,000	5,000	10,000	30,000	80,000

See Table 3 for footnotes.

1.2.4.1.4 molbloc-L Ranges with High Pressure Calibrations

Table 3. molbloc-L Ranges with High Pressure Calibrations

GASES			molbloc-L SIZE AND FULL SCALE FLOW (sccm @ 0 °C)									
			SIZE 1E1	SIZE 5E1	SIZE 1E2	SIZE 2E2	SIZE 5E2	SIZE 1E3	SIZE 5E3	SIZE 1E4	SIZE 3E4	SIZE 1E5
INERT	Nitrogen	N ₂	20	100	200	400	1,000	2,000	10,000	20,000	40,000 7,500	N/A
	Argon	Ar	20	100	200	400	1,000	2,000	10,000	17,000	35,000 6,000	N/A
	Helium	He	20	100	200	400	1,000	2,000	10,000	20,000	65,000	N/A
	Sulfur Hexafluoride	SF ₆	25	100 15	120 30	250 50	600 150	2,000 300	2,000 1,400	6,200 2,800	--	N/A
	Xenon	XE	20	100	150	350	650	1,700	3,350 950	11,000 1,900	11,000 5,700	N/A
FLAMMABLE	Butane	C ₄ H ₁₀	N/A	N/A	N/A	N/A	N/A	N/A	N/A	N/A	N/A	N/A
	Ethane	C ₂ H ₆	40	200	350 50	700 100	1,800 200	4,000	6,000 2,300	20,000 4,500	20,000 13,000	N/A
	Ethylene	C ₂ H ₄	40	200	350	700	2,000	4,000	7,000 2,000	22,000 4,000	22,000 12,700	N/A
	Hydrogen	H ₂	40	200	400	900	2,000	4,500	22,000	45,000	130,000	N/A
	Methane	CH ₄	35	175	350	700	1,700	3,500	13,000 2,000	33,000	42,000 12,000	N/A
	Propane	C ₃ H ₈	50	200 25	200 50	400 100	1,000 250	3,500 500	3,500 2,600	11,000 5,400	--	N/A
FLUORO-CARBONS	Carbon Tetrafluoride	CF ₄	20	100	200	400	1,000	2,000	3,700 1,200	12,000 2,400	12,000 7,300	N/A
	Hexafluoroethene	C ₂ F ₆	25	100 15	120 30	250 50	600 150	2,000 300	1,800 1,500	6,000 3,000	--	N/A
	Trifluoromethane	CHF ₃	25	125	240 30	450 60	1,200 150	2,500	4,000 1,500	12,000 3,000	12,000 8,800	N/A
OTHER	Air	Air	20	100	200	400	1,000	2,000	10,000	20,000	40,000 7,200	N/A
	Carbon Dioxide	CO ₂	25	125	250	500	1,250	2,500	6,600 1,400	20,000 2,500	20,000 8,800	N/A
	Carbon Monoxide	CO	20	100	200	400	1,000	2,000	10,000	20,000	40,000 7,500	N/A
	Nitrous Oxide	N ₂ O	25	125	250	500	1,250	2,500	11,000 1,500	20,000 3,000	20,000 9,000	N/A
	Octafluorocyclobutane ²	C ₄ F ₈	N/A	N/A	N/A	N/A	N/A	N/A	N/A	N/A	N/A	N/A
	Oxygen	O ₂	20	100	200	400	1,000	2,000	10,000	20,000	40,000 6,500	N/A

A bold value indicates that the maximum flow is limited by the maximum Reynolds number value of 1 200 which is reached before the normal differential pressure range is reached. In that case, the second value gives the minimum flow for which measurement uncertainty (accuracy) is equal to the nominal uncertainty specification. Divide the second value by 10 when using molbox RFM microrange option.

Where there is no value in the field (--), this indicates that the maximum Reynolds number is reached before the differential pressure reaches 5 kPa (1 kPa in the case of the 1E5 molbloc), therefore calibration with that gas is not useful.

¹ Due to low vapor pressure, only downstream calibration type is available.

² The operating pressure range is greater than the vapor pressure value for this gas.

1.2.4.1.5 molbloc-L DIMENSIONS

molbloc-L SIZES [mm(in.)]			
	5E3 AND LOWER	1E4, 3E4	1E5
A	58.50 (2.303)	74.50 (2.933)	74.50 (2.933)
B	16.00 (0.630)	24.00 (0.945)	24.00 (0.945)
C	32.00 (1.260) SQ	48.00 (1.890) SQ	48.00 (1.890) SQ
D	68.84 (2.750)	80.00 (3.150)	80.00 (3.150)
E	19.06 (0.750)	28.00 (1.102)	28.00 (1.102)
F	124.00 (4.881)	157.00 (6.181)	164.00 (6.458)
G	1/4 in. VCR M	1/4 in. VCR M	1/2 in. VCR M

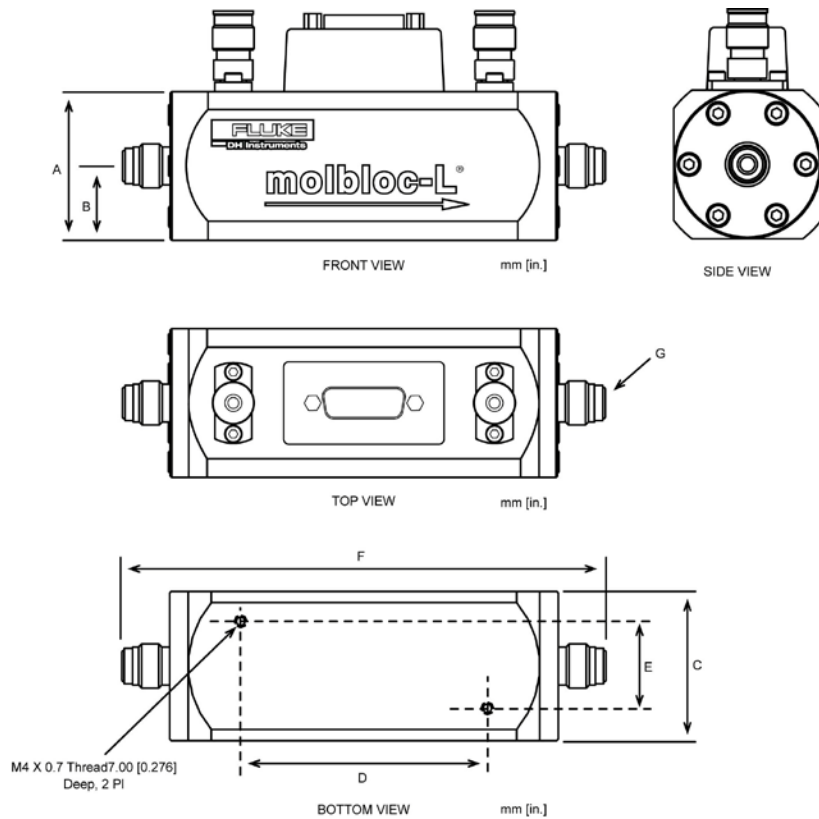

1.2.4.2 molbloc-S

The flow range and operating pressure associated with molbloc-S operation depend on the molbloc used and its calibration options (see Section 1.2.4.2.2)

Measurement Update Rate	1 second
Range	Depends on molbloc-S pressure dependent calibration type (see Section 1.2.4.2.2)
Resolution	0.01 % of FS
Linearity	± 0.25 % of reading
Repeatability	± 0.10 % of reading
Precision¹	± 0.30 % of reading
Predicted Stability² (1 year)	± 0.2 % of reading
Measurement Uncertainty³	± 0.5 % of reading from 50 to 500 kPa
With SP molbloc-S calibration	
Measurement Uncertainty³	± 0.5 % of reading from 50 to 200 kPa ± 0.5 % of 50 kPa flow from 20 to 50 kPa
With LP molbloc-S calibration	
Measurement Uncertainty³	± 0.5 % of reading from 200 to 600 kPa
With HP molbloc-S calibration	

- 1 Precision: Combined linearity, hysteresis, repeatability.
- 2 Stability: Maximum change in zero and span over specified time period for typical molbox RFM and molbloc used under typical conditions. As stability can only be predicted, stability for a specific molbloc and molbox RFM should be established from experience.
- 3 Measurement uncertainty (accuracy): Maximum deviation of the molbox RFM flow indication from the true value of the flow through the molbloc including precision, stability and Fluke calibration standard measurement uncertainty.

1.2.4.2.1 molbloc-S Pressure Dependent Calibration Types

Note

See your molbloc's Calibration Report to determine the calibration type of the molbloc you are using.

Measurement uncertainty (accuracy) specifications for molblocs are valid only for gases with which the molbloc has been calibrated. All molbloc-S elements are calibrated in one standard gas, either air or N₂, and may be calibrated in other gases. Calibrations with other gases are optional. The list of gases which can be measured by molbloc-S is the same as molbloc-L. **FLUKE** calibration capability is not maintained at all times for all gases on all molbloc designations. Check for availability before ordering calibrations.

molbloc-S calibrations are performed over flow ranges corresponding to one of three pressure ranges, summarized in Table 4.

Table 4: molbloc-S Calibration Types

CALIBRATION TYPE (CALIBRATION NAME)	OPERATING PRESSURE
Low pressure (LP)	20 to 200 kPa absolute (3 to 30 psia) upstream of molbloc
Standard pressure (SP)	50 to 500 kPa absolute (7 to 70 psia) upstream of molbloc
High pressure (HP)	200 to 2000 kPa absolute (29 to 290 psia) upstream of molbloc

Note

molbloc-S flow measurements are valid only when the ratio of pressure downstream to the pressure upstream of the nozzle is low enough to assure a critical (choked) flow (see Section 3.1.5).

1.2.4.2.2 molbloc-S Ranges

molbloc-S flow ranges are defined by the molbloc's Pressure to Flow Conversion Ratio, K_F , the gas used, the absolute pressure that can be delivered upstream of molbloc-S, the downstream pressure and the acceptable back pressure ratio (see Section 3.1.5). K_F is expressed in units of sccm/kPa and defines the relationship between mass flow in nitrogen and the absolute upstream pressure delivered to the molbloc-S. molbloc-S sizes are defined by the nominal K_F of the molbloc-S nozzle, using scientific notation, for example a 1E3 molbloc-S has a K_F of 1,000 sccm/kPa. To differentiate from molbloc-L size designations, this molbloc size is designated 1E3-S.

The molbox RFM pressure range, the molbloc-S calibration type (see Section 1.2.5.2.2) and the back pressure ratio (BPR) requirements limit the pressures, and flows, over which a molbloc-S can be used within known measurement uncertainty limits. In practice, the usable range of a molbloc-S in a given application also may depend on the available gas supply pressure, the presence and flow capacity of a vacuum pump downstream or the allowable back pressure on an upstream DUT.

The mass flow range of a molbloc-S element is dependent on the properties of the gas used, so the range of a molbloc-S is different for each supported gas. The flow ranges for each molbloc-S size at various typical operating pressures are summarized separately for each molbloc-S supported gas in the Tables below. For the common application of using a molbloc-S with its downstream pressure at or near atmospheric pressure, it is helpful to know what minimum flow can be measured before violating back pressure ratio requirements (see Section 3.1.5). In the tables below, this minimum flow value is given in the "Minimum without vacuum" column.

FLUKE calibration capability may not be available for some of the gases listed, or may be limited to less than the maximum flow rate listed. Check for availability before ordering calibrations.

The following notes apply to the range tables below:

Ratio = Inverse square root density ratio of the current gas to Nitrogen

K_F = Pressure to Flow Conversion Ratio, sccm/kPa

To estimate a flow in a given gas at a given pressure: $\text{Flow}(slm) = K_F * \text{Pressure in kPa absolute} / 1000 * \text{Gas Ratio}$

Table 5: N2. molbloc-S Flow in Nitrogen at Various molbloc Upstream Pressures

Nitrogen Ratio = 1		N2	molbloc-S MASS FLOW RATE (slm @ 0 °C) WHEN molbloc-S UPSTREAM PRESSURE IS:[1][2]								
DESIGNATOR	K _F [sccm/ kPa]	20 kPa (3 psia)	50 kPa (7 psia)	100 kPa (15 psia)	Minimum without vacuum ⁽³⁾	200 kPa (30 psia)	500 kPa (70 psia)	700 kPa (100 psia)	1.2 MPa (174 psia)	2 MPa (290 psia)	
1E1-S	10	0.2	0.5	1	2.0	2	5	7	12	20	
2E1-S	20	0.4	1	2	3.5	4	10	14	24	40	
5E1-S	50	1	2.5	5	7.7	10	25	35	60	100	
1E2-S	100	2	5	10	15	20	50	70	120	200	
2E2-S	200	4	10	20	28	40	100	140	240	400	
5E2-S	500	10	25	50	67	100	250	350	600	1,000	
1E3-S	1,000	20	50	100	129	200	500	700	1,200	2,000	
2E3-S	2,000	40	100	200	248	400	1,000	1,400	2,400	4,000	
5E3-S	5,000	100	250	500	596	1,000	2500	3,500	6,000	10,000	
1E4-S	10,000	200	500	1,000	1,173	2,000	5,000	7,000	12,000	20,000	

[1] Flow values in table are valid only when critical flow is established.

[2] When volumetrically based mass flow units with reference temperatures other than 0°C are used, flow values will generally be higher; the flow values for a given molbloc and upstream pressure are approximately 7% higher when expressed in slm at 20°C. Flow values at a given pressure may vary by up to ± 2% due to flowpath machining tolerances.

[3] Minimum upstream pressure to achieve critical flow with atmospheric pressure (approximately 100 kPa) downstream of molbloc-S (no vacuum).

Table 6: Ar. molbloc-S Flow in Argon at Various molbloc Upstream Pressures

Argon Ratio = 0.837		Ar	molbloc-S MASS FLOW RATE (slm @ 0 °C) WHEN molbloc-S UPSTREAM PRESSURE IS:[1][2]								
DESIGNATOR	K _F [sccm/ kPa]	20 kPa (3 psia)	50 kPa (7 psia)	100 kPa (15 psia)	Minimum without vacuum ⁽³⁾	200 kPa (30 psia)	500 kPa (70 psia)	700 kPa (100 psia)	1.2 MPa (174 psia)	2 MPa (290 psia)	
1E1-S	10	0.2	0.4	0.8	1.7	1.7	4.2	5.9	10.0	16.7	
2E1-S	20	0.3	0.8	1.7	3.0	3.3	8.4	11.7	20.1	33.5	
5E1-S	50	0.8	2.1	4.2	6.5	8.4	20.9	29.3	50.2	83.7	
1E2-S	100	1.7	4.2	8.4	12.9	16.7	41.9	58.6	100.5	167.4	
2E2-S	200	3.3	8.4	16.7	23.3	33.5	83.7	117.2	200.9	334.9	
5E2-S	500	8.4	20.9	41.9	57.1	83.7	209.3	293.0	502.3	837.2	
1E3-S	1,000	16.7	41.9	83.7	107.8	167.4	418.6	586.0	1,004.6	1,674.4	
2E3-S	2,000	33.5	83.7	167.4	207.6	334.9	837.2	1,172.1	2,009.3	3,348.8	
5E3-S	5,000	83.7	209.3	418.6	498.2	837.2	2,093.0	2,930.2	5,023.2	8,372.0	
1E4-S	10,000	167.4	418.6	837.2	996.2	1,674.4	4,186.0	5,860.4	10,046.4	16,744.0	

[1] Flow values in table are valid only when critical flow is established.

[2] When volumetrically based mass flow units with reference temperatures other than 0°C are used, flow values will generally be higher; the flow values for a given molbloc and upstream pressure are approximately 7% higher when expressed in slm at 20°C. Flow values at a given pressure may vary by up to ± 2% due to flowpath machining tolerances.

[3] Minimum upstream pressure to achieve critical flow with atmospheric pressure (approximately 100 kPa) downstream of molbloc-S (no vacuum).

Table 7: He. molbloc-S Flow in Helium at Various molbloc Upstream Pressures

Helium Ratio = 2.647		molbloc-S MASS FLOW RATE (slm @ 0 °C) WHEN molbloc-S UPSTREAM PRESSURE IS:[1][2]								
DESIGNATOR	K _F [sccm/ kPa]	He								
		20 kPa (3 psia)	50 kPa (7 psia)	100 kPa (15 psia)	Minimum without vacuum ⁽³⁾	200 kPa (30 psia)	500 kPa (70 psia)	700 kPa (100 psia)	1.2 MPa (174 psia)	2 MPa (290 psia)
1E1-S	10	0.5	1.3	2.6	9.4	5.3	13.2	18.5	31.8	52.9
2E1-S	20	1.1	2.6	5.3	13.1	10.6	26.5	37.1	63.5	105.9
5E1-S	50	2.6	6.6	13.2	25.7	26.5	66.2	92.6	158.8	264.7
1E2-S	100	5.3	13.2	26.5	51.4	52.9	132.3	185.3	317.6	529.4
2E2-S	200	10.6	26.5	52.9	91.5	105.9	264.7	370.6	635.2	1,058.7
5E2-S	500	26.5	66.2	132.3	199.4	264.7	661.7	926.4	1,588.1	2,646.8
1E3-S	1000	52.9	132.3	264.7	398.7	529.4	1,323.4	1,852.8	3,176.2	5,293.6
2E3-S	2000	105.9	264.7	529.4	695.1	1,058.7	2,646.8	3,705.5	6,352.3	10,587.2
5E3-S	5000	264.7	661.7	1,323.4	1,737.8	2,646.8	6,617.0	9,263.8	15,880.9	26,468.1
1E4-S	10,000	529.4	1,323.4	2,646.8	3,281.0	5,293.6	13,234.0	18,527.7	31,761.7	52,936.2

[1] Flow values in table are valid only when critical flow is established.

[2] When volumetrically based mass flow units with reference temperatures other than 0°C are used, flow values will generally be higher; the flow values for a given molbloc and upstream pressure are approximately 7% higher when expressed in slm at 20°C. Flow values at a given pressure may vary by up to ± 2% due to flowpath machining tolerances.

[3] Minimum upstream pressure to achieve critical flow with atmospheric pressure (approximately 100 kPa) downstream of molbloc-S (no vacuum).

Table 8: SF6. molbloc-S Flow in Sulfur Hexafluoride at Various molbloc Upstream Pressures

Sulfur Hexafluoride Ratio = 0.435		molbloc-S MASS FLOW RATE (slm @ 0 °C) WHEN molbloc-S UPSTREAM PRESSURE IS:[1][2]								
DESIGNATOR	K _F [sccm/ kPa]	SF6								
		20 kPa (3 psia)	50 kPa (7 psia)	100 kPa (15 psia)	Minimum without vacuum ⁽³⁾	200 kPa (30 psia)	500 kPa (70 psia)	700 kPa (100 psia)	1.2 MPa (174 psia)	2 MPa (290 psia)
1E1-S	10	0.1	0.2	0.4	0.8	0.9	2.2	3.0	n/a ^[4]	n/a ^[4]
2E1-S	20	0.2	0.4	0.9	1.4	1.7	4.3	6.1	n/a ^[4]	n/a ^[4]
5E1-S	50	0.4	1.1	2.2	3.1	4.3	10.9	15.2	n/a ^[4]	n/a ^[4]
1E2-S	100	0.9	2.2	4.3	5.9	8.7	21.7	30.4	n/a ^[4]	n/a ^[4]
2E2-S	200	1.7	4.3	8.7	11.4	17.4	43.5	60.9	n/a ^[4]	n/a ^[4]
5E2-S	500	4.3	10.9	21.7	26.9	43.5	108.7	152.2	n/a ^[4]	n/a ^[4]
1E3-S	1,000	8.7	21.7	43.5	53.8	87.0	217.4	304.3	n/a ^[4]	n/a ^[4]
2E3-S	2,000	17.4	43.5	87.0	100.0	173.9	434.8	608.7	n/a ^[4]	n/a ^[4]
5E3-S	5,000	43.5	108.7	217.4	249.9	434.8	1,086.9	1,521.7	n/a ^[4]	n/a ^[4]
1E4-S	10,000	87.0	217.4	434.8	499.7	869.5	2,173.8	3,043.4	n/a ^[4]	n/a ^[4]

[1] Flow values in table are valid only when critical flow is established.

[2] When volumetrically based mass flow units with reference temperatures other than 0°C are used, flow values will generally be higher; the flow values for a given molbloc and upstream pressure are approximately 7% higher when expressed in slm at 20°C. Flow values at a given pressure may vary by up to ± 2% due to flowpath machining tolerances.

[3] Minimum upstream pressure to achieve critical flow with atmospheric pressure (approximately 100 kPa) downstream of molbloc-S (no vacuum).

[4] Operation in this gas is limited to lower pressures due to the gas vapor pressure.

Table 9: Xe. molbloc-S Flow in Xenon at Various molbloc Upstream Pressures

Xenon Ratio = 0.460	Xe	molbloc-S MASS FLOW RATE (slm @ 0 °C) WHEN molbloc-S UPSTREAM PRESSURE IS:[1][2]								
DESIGNATOR	K _F [sccm/ kPa]	20 kPa (3 psia)	50 kPa (7 psia)	100 kPa (15 psia)	Minimum without vacuum ⁽³⁾	200 kPa (30 psia)	500 kPa (70 psia)	700 kPa (100 psia)	1.2 MPa (174 psia)	2 MPa (290 psia)
1E1-S	10	0.1	0.2	0.4	0.8	0.7	1.8	3.2	n/a ^[4]	n/a ^[4]
2E1-S	20	0.1	0.4	0.7	1.4	1.5	3.6	6.4	n/a ^[4]	n/a ^[4]
5E1-S	50	0.4	0.9	1.8	3.6	3.6	9.1	16.1	n/a ^[4]	n/a ^[4]
1E2-S	100	0.7	1.8	3.6	6.5	7.3	18.2	32.2	n/a ^[4]	n/a ^[4]
2E2-S	200	1.5	3.6	7.3	12.9	14.6	36.4	64.5	n/a ^[4]	n/a ^[4]
5E2-S	500	3.6	9.1	18.2	29.7	36.4	91.0	161.2	n/a ^[4]	n/a ^[4]
1E3-S	1,000	7.3	18.2	36.4	59.3	72.8	182.0	322.3	n/a ^[4]	n/a ^[4]
2E3-S	2,000	14.6	36.4	72.8	109.6	145.6	364.0	644.6	n/a ^[4]	n/a ^[4]
5E3-S	5,000	36.4	91.0	182.0	267.2	364.0	910.0	1,611.5	n/a ^[4]	n/a ^[4]
1E4-S	10,000	72.8	182.0	364.0	529.2	728.0	1,819.9	3,223.1	n/a ^[4]	n/a ^[4]

- [1] Flow values in table are valid only when critical flow is established.
- [2] When volumetrically based mass flow units with reference temperatures other than 0°C are used, flow values will generally be higher; the flow values for a given molbloc and upstream pressure are approximately 7% higher when expressed in slm at 20°C. Flow values at a given pressure may vary by up to ± 2% due to flowpath machining tolerances.
- [3] Minimum upstream pressure to achieve critical flow with atmospheric pressure (approximately 100 kPa) downstream of molbloc-S (no vacuum).
- [4] Operation in this gas is limited to lower pressures due to the gas vapor pressure.

Table 10: C4H10. molbloc-S Flow in Butane at Various molbloc Upstream Pressures

Butane Ratio = 0.680	C4H10	molbloc-S MASS FLOW RATE (slm @ 0 °C) WHEN molbloc-S UPSTREAM PRESSURE IS:[1][2]								
DESIGNATOR	K _F [sccm/ kPa]	20 kPa (3 psia)	50 kPa (7 psia)	100 kPa (15 psia)	Minimum without vacuum ⁽³⁾	200 kPa (30 psia)	500 kPa (70 psia)	700 kPa (100 psia)	1.2 MPa (174 psia)	2 MPa (290 psia)
1E1-S	10	0.1	0.3	0.7	1.0	1.4	n/a ^[4]	n/a ^[4]	n/a ^[4]	n/a ^[4]
2E1-S	20	0.3	0.7	1.4	1.9	2.7	n/a ^[4]	n/a ^[4]	n/a ^[4]	n/a ^[4]
5E1-S	50	0.7	1.7	3.4	4.8	6.8	n/a ^[4]	n/a ^[4]	n/a ^[4]	n/a ^[4]
1E2-S	100	1.4	3.4	6.8	9.0	13.6	n/a ^[4]	n/a ^[4]	n/a ^[4]	n/a ^[4]
2E2-S	200	2.7	6.8	13.6	18.0	27.2	n/a ^[4]	n/a ^[4]	n/a ^[4]	n/a ^[4]
5E2-S	500	6.8	17.0	34.0	42.2	68.0	n/a ^[4]	n/a ^[4]	n/a ^[4]	n/a ^[4]
1E3-S	1,000	13.6	34.0	68.0	84.4	136.0	n/a ^[4]	n/a ^[4]	n/a ^[4]	n/a ^[4]
2E3-S	2,000	27.2	68.0	136.0	157.0	272.0	n/a ^[4]	n/a ^[4]	n/a ^[4]	n/a ^[4]
5E3-S	5,000	68.0	170.0	340.0	392.4	679.9	n/a ^[4]	n/a ^[4]	n/a ^[4]	n/a ^[4]
1E4-S	10,000	136.0	340.0	679.9	784.9	1,359.8	n/a ^[4]	n/a ^[4]	n/a ^[4]	n/a ^[4]

- [1] Flow values in table are valid only when critical flow is established.
- [2] When volumetrically based mass flow units with reference temperatures other than 0°C are used, flow values will generally be higher; the flow values for a given molbloc and upstream pressure are approximately 7% higher when expressed in slm at 20°C. Flow values at a given pressure may vary by up to ± 2% due to flowpath machining tolerances.
- [3] Minimum upstream pressure to achieve critical flow with atmospheric pressure (approximately 100 kPa) downstream of molbloc-S (no vacuum).
- [4] Operation in this gas is limited to lower pressures due to the gas vapor pressure.

Table 11: C2H6. molbloc-S Flow in Ethane at Various molbloc Upstream Pressures

Ethane Ratio = 0.960	C2H6	molbloc-S MASS FLOW RATE (slm @ 0 °C) WHEN molbloc-S UPSTREAM PRESSURE IS:[1][2]									
		DESIGNATOR	K _F [sccm/ kPa]	20 kPa (3 psia)	50 kPa (7 psia)	100 kPa (15 psia)	Minimum without vacuum ⁽³⁾	200 kPa (30 psia)	500 kPa (70 psia)	700 kPa (100 psia)	1.2 MPa (174 psia)
1E1-S	10		0.2	0.5	1.0	1.5	1.9	4.8	6.7	n/a ^[4]	n/a ^[4]
2E1-S	20		0.4	1.0	1.9	3.0	3.8	9.6	13.4	n/a ^[4]	n/a ^[4]
5E1-S	50		1.0	2.4	4.8	6.7	9.6	24.0	33.6	n/a ^[4]	n/a ^[4]
1E2-S	100		1.9	4.8	9.6	13.4	19.2	48.0	67.2	n/a ^[4]	n/a ^[4]
2E2-S	200		3.8	9.6	19.2	25.2	38.4	96.0	134.5	n/a ^[4]	n/a ^[4]
5E2-S	500		9.6	24.0	48.0	61.9	96.0	240.1	336.1	n/a ^[4]	n/a ^[4]
1E3-S	1,000		19.2	48.0	96.0	118.7	192.1	480.2	672.3	n/a ^[4]	n/a ^[4]
2E3-S	2,000		38.4	96.0	192.1	228.6	384.2	960.4	1,344.6	n/a ^[4]	n/a ^[4]
5E3-S	5,000		96.0	240.1	480.2	551.9	960.4	2,401.0	3,361.4	n/a ^[4]	n/a ^[4]
1E4-S	10,000		192.1	480.2	960.4	1,103.8	1,920.8	4,802.0	6,722.8	n/a ^[4]	n/a ^[4]

[1] Flow values in table are valid only when critical flow is established.

[2] When volumetrically based mass flow units with reference temperatures other than 0°C are used, flow values will generally be higher; the flow values for a given molbloc and upstream pressure are approximately 7% higher when expressed in slm at 20°C. Flow values at a given pressure may vary by up to ± 2% due to flowpath machining tolerances.

[3] Minimum upstream pressure to achieve critical flow with atmospheric pressure (approximately 100 kPa) downstream of molbloc-S (no vacuum).

[4] Operation in this gas is limited to lower pressures due to the gas vapor pressure.

Table 12: C2H4. molbloc-S Flow in Ethylene at Various molbloc Upstream Pressures

Ethylene Ratio = 0.996	C2H4	molbloc-S MASS FLOW RATE (slm @ 0 °C) WHEN molbloc-S UPSTREAM PRESSURE IS:[1][2]									
		DESIGNATOR	K _F [sccm/ kPa]	20 kPa (3 psia)	50 kPa (7 psia)	100 kPa (15 psia)	Minimum without vacuum ⁽³⁾	200 kPa (30 psia)	500 kPa (70 psia)	700 kPa (100 psia)	1.2 MPa (174 psia)
1E1-S	10		0.2	0.5	1.0	1.7	2.0	5.0	7.0	n/a ^[4]	n/a ^[4]
2E1-S	20		0.4	1.0	2.0	3.1	4.0	10.0	13.9	n/a ^[4]	n/a ^[4]
5E1-S	50		1.0	2.5	5.0	7.5	10.0	24.9	34.9	n/a ^[4]	n/a ^[4]
1E2-S	100		2.0	5.0	10.0	13.9	19.9	49.8	69.7	n/a ^[4]	n/a ^[4]
2E2-S	200		4.0	10.0	19.9	27.7	39.8	99.6	139.4	n/a ^[4]	n/a ^[4]
5E2-S	500		10.0	24.9	49.8	64.2	99.6	248.9	348.5	n/a ^[4]	n/a ^[4]
1E3-S	1,000		19.9	49.8	99.6	128.2	199.2	497.9	697.0	n/a ^[4]	n/a ^[4]
2E3-S	2,000		39.8	99.6	199.2	237.0	398.3	995.8	1394.1	n/a ^[4]	n/a ^[4]
5E3-S	5,000		99.6	248.9	497.9	572.2	995.8	2,489.5	3485.2	n/a ^[4]	n/a ^[4]
1E4-S	10,000		199.2	497.9	995.8	1,144.4	1,991.6	4,978.9	6970.5	n/a ^[4]	n/a ^[4]

[1] Flow values in table are valid only when critical flow is established.

[2] When volumetrically based mass flow units with reference temperatures other than 0°C are used, flow values will generally be higher; the flow values for a given molbloc and upstream pressure are approximately 7% higher when expressed in slm at 20°C. Flow values at a given pressure may vary by up to ± 2% due to flowpath machining tolerances.

[3] Minimum upstream pressure to achieve critical flow with atmospheric pressure (approximately 100 kPa) downstream of molbloc-S (no vacuum).

[4] Operation in this gas is limited to lower pressures due to the gas vapor pressure.

Table 13: H2. molbloc-S Flow in Hydrogen at Various molbloc Upstream Pressures

Hydrogen Ratio = 3.730		H2								
		molbloc-S MASS FLOW RATE (slm @ 0 °C) WHEN molbloc-S UPSTREAM PRESSURE IS:[1][2]								
DESIGNATOR	K _F [sccm/ kPa]	20 kPa (3 psia)	50 kPa (7 psia)	100 kPa (15 psia)	Minimum without vacuum ⁽³⁾	200 kPa (30 psia)	500 kPa (70 psia)	700 kPa (100 psia)	1.2 MPa (174 psia)	2 MPa (290 psia)
1E1-S	10	0.7	1.9	3.7	8.3	7.5	18.6	26.1	44.8	74.6
2E1-S	20	1.5	3.7	7.5	14.5	14.9	37.3	52.2	89.5	149.2
5E1-S	50	3.7	9.3	18.6	36.2	37.3	93.2	130.5	223.8	373.0
1E2-S	100	7.5	18.6	37.3	62.5	74.6	186.5	261.1	447.6	746.0
2E2-S	200	14.9	37.3	74.6	114.5	149.2	373.0	522.2	895.2	1,491.9
5E2-S	500	37.3	93.2	186.5	280.9	373.0	932.4	1,305.4	2,237.9	3,729.8
1E3-S	1,000	74.6	186.5	373.0	508.7	746.0	1,864.9	2,610.9	4,475.8	7,459.6
2E3-S	2,000	149.2	373.0	746.0	979.6	1,491.9	3,729.8	5,221.7	8,951.5	14,919.2
5E3-S	5,000	373.0	932.4	1,864.9	2,311.7	3,729.8	9,324.5	13,054.3	22,378.8	37,297.9
1E4-S	10,000	746.0	1,864.9	3,729.8	4,623.4	7,459.6	18,649.0	26,108.6	44,757.5	74,595.9

[1] Flow values in table are valid only when critical flow is established.

[2] When volumetrically based mass flow units with reference temperatures other than 0°C are used, flow values will generally be higher; the flow values for a given molbloc and upstream pressure are approximately 7% higher when expressed in slm at 20°C. Flow values at a given pressure may vary by up to ± 2% due to flowpath machining tolerances.

[3] Minimum upstream pressure to achieve critical flow with atmospheric pressure (approximately 100 kPa) downstream of molbloc-S (no vacuum).

Table 14: CH4. molbloc-S Flow in Methane at Various molbloc Upstream Pressures

Methane Ratio = 1.320		CH4								
		molbloc-S MASS FLOW RATE (slm @ 0 °C) WHEN molbloc-S UPSTREAM PRESSURE IS:[1][2]								
DESIGNATOR	K _F [sccm/ kPa]	20 kPa (3 psia)	50 kPa (7 psia)	100 kPa (15 psia)	Minimum without vacuum ⁽³⁾	200 kPa (30 psia)	500 kPa (70 psia)	700 kPa (100 psia)	1.2 MPa (174 psia)	2 MPa (290 psia)
1E1-S	10	0.3	0.7	1.3	2.6	2.6	6.6	9.2	15.8	26.4
2E1-S	20	0.5	1.3	2.6	4.4	5.3	13.2	18.5	31.7	52.8
5E1-S	50	1.3	3.3	6.6	10.2	13.2	33.0	46.2	79.2	132.0
1E2-S	100	2.6	6.6	13.2	20.1	26.4	66.0	92.4	158.4	264.0
2E2-S	200	5.3	13.2	26.4	36.7	52.8	132.0	184.8	316.8	528.1
5E2-S	500	13.2	33.0	66.0	88.2	132.0	330.0	462.1	792.1	1,320.2
1E3-S	1,000	26.4	66.0	132.0	170.0	264.0	660.1	924.1	1,584.2	2,640.3
2E3-S	2,000	52.8	132.0	264.0	327.3	528.1	1,320.2	1,848.2	3,168.4	5,280.6
5E3-S	5,000	132.0	330.0	660.1	785.5	1,320.2	3,300.4	4,620.5	7,920.9	13,201.5
1E4-S	10,000	264.0	660.1	1,320.2	1,517.2	2,640.3	6,600.8	9,241.1	15,841.8	26,403.0

[1] Flow values in table are valid only when critical flow is established.

[2] When volumetrically based mass flow units with reference temperatures other than 0°C are used, flow values will generally be higher; the flow values for a given molbloc and upstream pressure are approximately 7% higher when expressed in slm at 20°C. Flow values at a given pressure may vary by up to ± 2% due to flowpath machining tolerances.

[3] Minimum upstream pressure to achieve critical flow with atmospheric pressure (approximately 100 kPa) downstream of molbloc-S (no vacuum).

Table 15: C3H8. molbloc-S Flow in Propane at Various molbloc Upstream Pressures

Propane Ratio = 0.789	C3H8	molbloc-S MASS FLOW RATE (slm @ 0 °C) WHEN molbloc-S UPSTREAM PRESSURE IS:[1][2]										
		DESIGNATOR	K _F [sccm/ kPa]	20 kPa (3 psia)	50 kPa (7 psia)	100 kPa (15 psia)	Minimum without vacuum ⁽³⁾	200 kPa (30 psia)	500 kPa (70 psia)	700 kPa (100 psia)	1.2 MPa (174 psia)	2 MPa (290 psia)
	10	1E1-S	10	0.2	0.4	0.8	1.3	1.6	3.9	5.5	n/a ^[4]	n/a ^[4]
	20	2E1-S	20	0.3	0.8	1.6	2.3	3.2	7.9	11.0	n/a ^[4]	n/a ^[4]
	50	5E1-S	50	0.8	2.0	3.9	5.5	7.9	19.7	27.6	n/a ^[4]	n/a ^[4]
	100	1E2-S	100	1.6	3.9	7.9	10.5	15.8	39.4	55.2	n/a ^[4]	n/a ^[4]
	200	2E2-S	200	3.2	7.9	15.8	20.8	31.5	78.9	110.4	n/a ^[4]	n/a ^[4]
	500	5E2-S	500	7.9	19.7	39.4	48.8	78.9	197.2	276.1	n/a ^[4]	n/a ^[4]
	1,000	1E3-S	1,000	15.8	39.4	78.9	97.5	157.7	394.4	552.1	n/a ^[4]	n/a ^[4]
	2,000	2E3-S	2,000	31.5	78.9	157.7	181.4	315.5	788.7	1,104.2	n/a ^[4]	n/a ^[4]
	5,000	5E3-S	5,000	78.9	197.2	394.4	453.2	788.7	1,971.8	2,760.5	n/a ^[4]	n/a ^[4]
	10,000	1E4-S	10,000	157.7	394.4	788.7	906.5	1,577.4	3,943.6	5,521.0	n/a ^[4]	n/a ^[4]

[1] Flow values in table are valid only when critical flow is established.

[2] When volumetrically based mass flow units with reference temperatures other than 0°C are used, flow values will generally be higher; the flow values for a given molbloc and upstream pressure are approximately 7% higher when expressed in slm at 20°C. Flow values at a given pressure may vary by up to ± 2% due to flowpath machining tolerances.

[3] Minimum upstream pressure to achieve critical flow with atmospheric pressure (approximately 100 kPa) downstream of molbloc-S (no vacuum).

[4] Operation in this gas is limited to lower pressures due to the gas vapor pressure.

Table 16: CF4. molbloc-S Flow in Carbon Tetrafluoride at Various molbloc Upstream Pressures

Carbon Tetrafluoride Ratio = 0.563	CF4	molbloc-S MASS FLOW RATE (slm @ 0 °C) WHEN molbloc-S UPSTREAM PRESSURE IS:[1][2]										
		DESIGNATOR	K _F [sccm/ kPa]	20 kPa (3 psia)	50 kPa (7 psia)	100 kPa (15 psia)	Minimum without vacuum ⁽³⁾	200 kPa (30 psia)	500 kPa (70 psia)	700 kPa (100 psia)	1.2 MPa (174 psia)	2 MPa (290 psia)
	10	1E1-S	10	0.1	0.3	0.6	0.9	1.1	2.8	3.9	n/a ^[4]	n/a ^[4]
	20	2E1-S	20	0.2	0.6	1.1	1.8	2.3	5.6	7.9	n/a ^[4]	n/a ^[4]
	50	5E1-S	50	0.6	1.4	2.8	4.1	5.6	14.1	19.7	n/a ^[4]	n/a ^[4]
	100	1E2-S	100	1.1	2.8	5.6	7.9	11.3	28.1	39.4	n/a ^[4]	n/a ^[4]
	200	2E2-S	200	2.3	5.6	11.3	15.7	22.5	56.3	78.8	n/a ^[4]	n/a ^[4]
	500	5E2-S	500	5.6	14.1	28.1	36.3	56.3	140.7	197.0	n/a ^[4]	n/a ^[4]
	1,000	1E3-S	1,000	11.3	28.1	56.3	69.9	112.6	281.4	394.0	n/a ^[4]	n/a ^[4]
	2,000	2E3-S	2,000	22.5	56.3	112.6	134.1	225.1	562.9	788.0	n/a ^[4]	n/a ^[4]
	5,000	5E3-S	5,000	56.3	140.7	281.4	323.4	562.9	1,407.2	1,970.0	n/a ^[4]	n/a ^[4]
	10,000	1E4-S	10,000	112.6	281.4	562.9	646.9	1,125.7	2,814.3	3,940.1	n/a ^[4]	n/a ^[4]

[1] Flow values in table are valid only when critical flow is established.

[2] When volumetrically based mass flow units with reference temperatures other than 0°C are used, flow values will generally be higher; the flow values for a given molbloc and upstream pressure are approximately 7% higher when expressed in slm at 20°C. Flow values at a given pressure may vary by up to ± 2% due to flowpath machining tolerances.

[3] Minimum upstream pressure to achieve critical flow with atmospheric pressure (approximately 100 kPa) downstream of molbloc-S (no vacuum).

[4] Operation in this gas is limited to lower pressures due to the gas vapor pressure.

Table 17: C2F6. molbloc-S Flow in Hexafluoroethene at Various molbloc Upstream Pressures

Hexafluoroethene Ratio = 0.447 C2F6		molbloc-S MASS FLOW RATE (slm @ 0 °C) WHEN molbloc-S UPSTREAM PRESSURE IS:[1][2]								
DESIGNATOR	K _F [sccm/ kPa]	20 kPa (3 psia)	50 kPa (7 psia)	100 kPa (15 psia)	Minimum without vacuum ⁽³⁾	200 kPa (30 psia)	500 kPa (70 psia)	700 kPa (100 psia)	1.2 MPa (174 psia)	2 MPa (290 psia)
1E1-S	10	0.1	0.2	0.4	0.8	0.9	2.2	3.1	n/a ^[4]	n/a ^[4]
2E1-S	20	0.2	0.4	0.9	1.3	1.8	4.5	6.3	n/a ^[4]	n/a ^[4]
5E1-S	50	0.4	1.1	2.2	3.2	4.5	11.2	15.7	n/a ^[4]	n/a ^[4]
1E2-S	100	0.9	2.2	4.5	5.9	8.9	22.4	31.3	n/a ^[4]	n/a ^[4]
2E2-S	200	1.8	4.5	8.9	11.8	17.9	44.7	62.6	n/a ^[4]	n/a ^[4]
5E2-S	500	4.5	11.2	22.4	27.6	44.7	111.8	156.6	n/a ^[4]	n/a ^[4]
1E3-S	1,000	8.9	22.4	44.7	55.3	89.5	223.7	313.1	n/a ^[4]	n/a ^[4]
2E3-S	2,000	17.9	44.7	89.5	102.9	178.9	447.3	626.3	n/a ^[4]	n/a ^[4]
5E3-S	5,000	44.7	111.8	223.7	257.1	447.3	1,118.3	1,565.7	n/a ^[4]	n/a ^[4]
1E4-S	10,000	89.5	223.7	447.3	514.1	894.7	2,236.7	3,131.3	n/a ^[4]	n/a ^[4]

- [1] Flow values in table are valid only when critical flow is established.
- [2] When volumetrically based mass flow units with reference temperatures other than 0°C are used, flow values will generally be higher; the flow values for a given molbloc and upstream pressure are approximately 7% higher when expressed in slm at 20°C. Flow values at a given pressure may vary by up to ± 2% due to flowpath machining tolerances.
- [3] Minimum upstream pressure to achieve critical flow with atmospheric pressure (approximately 100 kPa) downstream of molbloc-S (no vacuum).
- [4] Operation in this gas is limited to lower pressures due to the gas vapor pressure.

Table 18: CHF3. molbloc-S Flow in Trifluoromethane at Various molbloc Upstream Pressures

Trifluoromethane Ratio = 0.629 CHF3		molbloc-S MASS FLOW RATE (slm @ 0 °C) WHEN molbloc-S UPSTREAM PRESSURE IS:[1][2]								
DESIGNATOR	K _F [sccm/ kPa]	20 kPa (3 psia)	50 kPa (7 psia)	100 kPa (15 psia)	Minimum without vacuum ⁽³⁾	200 kPa (30 psia)	500 kPa (70 psia)	700 kPa (100 psia)	1.2 MPa (174 psia)	2 MPa (290 psia)
1E1-S	10	0.1	0.3	0.6	1.0	1.3	3.1	4.4	n/a ^[4]	n/a ^[4]
2E1-S	20	0.3	0.6	1.3	2.0	2.5	6.3	8.8	n/a ^[4]	n/a ^[4]
5E1-S	50	0.6	1.6	3.1	4.4	6.3	15.7	22.0	n/a ^[4]	n/a ^[4]
1E2-S	100	1.3	3.1	6.3	8.8	12.6	31.5	44.1	n/a ^[4]	n/a ^[4]
2E2-S	200	2.5	6.3	12.6	17.2	25.2	62.9	88.1	n/a ^[4]	n/a ^[4]
5E2-S	500	6.3	15.7	31.5	40.6	62.9	157.3	220.3	n/a ^[4]	n/a ^[4]
1E3-S	1,000	12.6	31.5	62.9	77.9	125.9	314.7	440.6	n/a ^[4]	n/a ^[4]
2E3-S	2,000	25.2	62.9	125.9	149.9	251.8	629.4	881.1	n/a ^[4]	n/a ^[4]
5E3-S	5,000	62.9	157.3	314.7	361.7	629.4	1,573.4	2202.8	n/a ^[4]	n/a ^[4]
1E4-S	10,000	125.9	314.7	629.4	723.3	1,258.8	3,146.9	4405.6	n/a ^[4]	n/a ^[4]

- [1] Flow values in table are valid only when critical flow is established.
- [2] When volumetrically based mass flow units with reference temperatures other than 0°C are used, flow values will generally be higher; the flow values for a given molbloc and upstream pressure are approximately 7% higher when expressed in slm at 20°C. Flow values at a given pressure may vary by up to ± 2% due to flowpath machining tolerances.
- [3] Minimum upstream pressure to achieve critical flow with atmospheric pressure (approximately 100 kPa) downstream of molbloc-S (no vacuum).
- [4] Operation in this gas is limited to lower pressures due to the gas vapor pressure.

Table 19: Air. molbloc-S Flow in Air at Various molbloc Upstream Pressures

Air Ratio = 0.983		molbloc-S MASS FLOW RATE (slm @ 0 °C) WHEN molbloc-S UPSTREAM PRESSURE IS:[1][2]								
DESIGNATOR	K _F [sccm/ kPa]	20 kPa (3 psia)	50 kPa (7 psia)	100 kPa (15 psia)	Minimum without vacuum ⁽³⁾	200 kPa (30 psia)	500 kPa (70 psia)	700 kPa (100 psia)	1.2 MPa (174 psia)	2 MPa (290 psia)
	1E1-S	10	0.2	0.5	1.0	2.0	2.0	4.9	6.9	11.8
2E1-S	20	0.4	1.0	2.0	3.4	3.9	9.8	13.8	23.6	39.3
5E1-S	50	1.0	2.5	4.9	7.6	9.8	24.6	34.4	59.0	98.3
1E2-S	100	2.0	4.9	9.8	15.2	19.7	49.2	68.8	118.0	196.7
2E2-S	200	3.9	9.8	19.7	27.4	39.3	98.3	137.7	236.0	393.4
5E2-S	500	9.8	24.6	49.2	67.1	98.3	245.9	344.2	590.1	983.5
1E3-S	1,000	19.7	49.2	98.3	126.7	196.7	491.7	688.4	1,180.2	1,967.0
2E3-S	2,000	39.3	98.3	196.7	243.9	393.4	983.5	1,376.9	2,360.4	3,933.9
5E3-S	5,000	98.3	245.9	491.7	585.2	983.5	2,458.7	3,442.2	5,900.9	9,834.8
1E4-S	10,000	196.7	491.7	983.5	1,170.3	1,967.0	4,917.4	6,884.4	11,801.8	19,669.7

[1] Flow values in table are valid only when critical flow is established.

[2] When volumetrically based mass flow units with reference temperatures other than 0°C are used, flow values will generally be higher; the flow values for a given molbloc and upstream pressure are approximately 7% higher when expressed in slm at 20°C. Flow values at a given pressure may vary by up to ± 2% due to flowpath machining tolerances.

[3] Minimum upstream pressure to achieve critical flow with atmospheric pressure (approximately 100 kPa) downstream of molbloc-S (no vacuum).

Table 20: CO₂. molbloc-S Flow in Carbon Dioxide at Various molbloc Upstream Pressures

Carbon Dioxide Ratio = 0.795		molbloc-S MASS FLOW RATE (slm @ 0 °C) WHEN molbloc-S UPSTREAM PRESSURE IS:[1][2]								
DESIGNATOR	K _F [sccm/ kPa]	20 kPa (3 psia)	50 kPa (7 psia)	100 kPa (15 psia)	Minimum without vacuum ⁽³⁾	200 kPa (30 psia)	500 kPa (70 psia)	700 kPa (100 psia)	1.2 MPa (174 psia)	2 MPa (290 psia)
	1E1-S	10	0.2	0.4	0.8	1.4	1.6	4.0	5.6	n/a ^[4]
2E1-S	20	0.3	0.8	1.6	2.5	3.2	8.0	11.1	n/a ^[4]	n/a ^[4]
5E1-S	50	0.8	2.0	4.0	6.2	8.0	19.9	27.8	n/a ^[4]	n/a ^[4]
1E2-S	100	1.6	4.0	8.0	11.1	15.9	39.8	55.7	n/a ^[4]	n/a ^[4]
2E2-S	200	3.2	8.0	15.9	22.1	31.8	79.5	111.3	n/a ^[4]	n/a ^[4]
5E2-S	500	8.0	19.9	39.8	51.2	79.5	198.8	278.4	n/a ^[4]	n/a ^[4]
1E3-S	1,000	15.9	39.8	79.5	102.4	159.1	397.7	556.7	n/a ^[4]	n/a ^[4]
2E3-S	2,000	31.8	79.5	159.1	189.3	318.1	795.3	1,113.4	n/a ^[4]	n/a ^[4]
5E3-S	5,000	79.5	198.8	397.7	473.2	795.3	1,988.3	2,783.6	n/a ^[4]	n/a ^[4]
1E4-S	10,000	159.1	397.7	795.3	914.1	1,590.6	3,976.6	5,567.2	n/a ^[4]	n/a ^[4]

[1] Flow values in table are valid only when critical flow is established.

[2] When volumetrically based mass flow units with reference temperatures other than 0°C are used, flow values will generally be higher; the flow values for a given molbloc and upstream pressure are approximately 7% higher when expressed in slm at 20°C. Flow values at a given pressure may vary by up to ± 2% due to flowpath machining tolerances.

[3] Minimum upstream pressure to achieve critical flow with atmospheric pressure (approximately 100 kPa) downstream of molbloc-S (no vacuum).

[4] Operation in this gas is limited to lower pressures due to the gas vapor pressure.

Table 21: CO. molbloc-S Flow in Carbon Monoxide at Various molbloc Upstream Pressures

Carbon Monoxide Ratio = 1.000		molbloc-S MASS FLOW RATE (slm @ 0 °C) WHEN molbloc-S UPSTREAM PRESSURE IS:[1][2]								
DESIGNATOR	K _F [sccm/ kPa]	20 kPa (3 psia)	50 kPa (7 psia)	100 kPa (15 psia)	Minimum without vacuum ⁽³⁾	200 kPa (30 psia)	500 kPa (70 psia)	700 kPa (100 psia)	1.2 MPa (174 psia)	2 MPa (290 psia)
	1E1-S	10	0.2	0.5	1.0	2.0	2.0	5.0	7.0	12.0
2E1-S	20	0.4	1.0	2.0	3.5	4.0	10.0	14.0	24.0	40.0
5E1-S	50	1.0	2.5	5.0	7.7	10.0	25.0	35.0	60.0	100.0
1E2-S	100	2.0	5.0	10.0	15.4	20.0	50.0	70.0	120.0	200.0
2E2-S	200	4.0	10.0	20.0	27.8	40.0	100.0	140.0	240.0	400.0
5E2-S	500	10.0	25.0	50.0	68.3	100.0	250.0	350.0	600.0	1,000.0
1E3-S	1,000	20.0	50.0	100.0	128.7	200.0	500.0	700.0	1,200.0	1,999.9
2E3-S	2,000	40.0	100.0	200.0	247.9	400.0	1,000.0	1,399.9	2,399.9	3,999.9
5E3-S	5,000	100.0	250.0	500.0	595.0	1,000.0	2,499.9	3,499.9	5,999.8	9,999.6
1E4-S	10,000	200.0	500.0	1,000.0	1,190.0	1,999.9	4,999.8	6,999.7	11,999.6	19,999.3

[1] Flow values in table are valid only when critical flow is established.

[2] When volumetrically based mass flow units with reference temperatures other than 0°C are used, flow values will generally be higher; the flow values for a given molbloc and upstream pressure are approximately 7% higher when expressed in slm at 20°C. Flow values at a given pressure may vary by up to ± 2% due to flowpath machining tolerances.

[3] Minimum upstream pressure to achieve critical flow with atmospheric pressure (approximately 100 kPa) downstream of molbloc-S (no vacuum).

Table 22: N2O. molbloc-S Flow in Nitrous Oxide at Various molbloc Upstream Pressures

Nitrous Oxide Ratio = 0.795		molbloc-S MASS FLOW RATE (slm @ 0 °C) WHEN molbloc-S UPSTREAM PRESSURE IS:[1][2]								
DESIGNATOR	K _F [sccm/ kPa]	20 kPa (3 psia)	50 kPa (7 psia)	100 kPa (15 psia)	Minimum without vacuum ⁽³⁾	200 kPa (30 psia)	500 kPa (70 psia)	700 kPa (100 psia)	1.2 MPa (174 psia)	2 MPa (290 psia)
	1E1-S	10	0.2	0.4	0.8	1.4	1.6	4.0	5.6	n/a ^[4]
2E1-S	20	0.3	0.8	1.6	2.5	3.2	8.0	11.1	n/a ^[4]	n/a ^[4]
5E1-S	50	0.8	2.0	4.0	6.2	8.0	19.9	27.8	n/a ^[4]	n/a ^[4]
1E2-S	100	1.6	4.0	8.0	11.1	15.9	39.8	55.7	n/a ^[4]	n/a ^[4]
2E2-S	200	3.2	8.0	15.9	22.1	31.8	79.5	111.3	n/a ^[4]	n/a ^[4]
5E2-S	500	8.0	19.9	39.8	51.2	79.5	198.8	278.3	n/a ^[4]	n/a ^[4]
1E3-S	1,000	15.9	39.8	79.5	102.4	159.0	397.6	556.6	n/a ^[4]	n/a ^[4]
2E3-S	2,000	31.8	79.5	159.0	189.3	318.0	795.1	1,113.2	n/a ^[4]	n/a ^[4]
5E3-S	5,000	79.5	198.8	397.6	473.1	795.1	1,987.8	2,782.9	n/a ^[4]	n/a ^[4]
1E4-S	10,000	159.0	397.6	795.1	913.7	1,590.2	3,975.6	5,565.8	n/a ^[4]	n/a ^[4]

[1] Flow values in table are valid only when critical flow is established.

[2] When volumetrically based mass flow units with reference temperatures other than 0°C are used, flow values will generally be higher; the flow values for a given molbloc and upstream pressure are approximately 7% higher when expressed in slm at 20°C. Flow values at a given pressure may vary by up to ± 2% due to flowpath machining tolerances.

[3] Minimum upstream pressure to achieve critical flow with atmospheric pressure (approximately 100 kPa) downstream of molbloc-S (no vacuum).

[4] Operation in this gas is limited to lower pressures due to the gas vapor pressure.

Table 23: C4F8. molbloc-S Flow in Octafluorocyclobutane1 at Various molbloc Upstream Pressures

Octafluorocyclobutane1 Ratio = 0.367 C4F8		molbloc-S MASS FLOW RATE (slm @ 0 °C) WHEN molbloc-S UPSTREAM PRESSURE IS:[1][2]								
DESIGNATOR	K _F [sccm/ kPa]	20 kPa (3 psia)	50 kPa (7 psia)	100 kPa (15 psia)	Minimum without vacuum ⁽³⁾	200 kPa (30 psia)	500 kPa (70 psia)	700 kPa (100 psia)	1.2 MPa (174 psia)	2 MPa (290 psia)
1E1-S	10	0.1	0.2	0.4	0.6	0.7	n/a ^[4]	n/a ^[4]	n/a ^[4]	n/a ^[4]
2E1-S	20	0.1	0.4	0.7	1.1	1.5	n/a ^[4]	n/a ^[4]	n/a ^[4]	n/a ^[4]
5E1-S	50	0.4	0.9	1.8	2.4	3.7	n/a ^[4]	n/a ^[4]	n/a ^[4]	n/a ^[4]
1E2-S	100	0.7	1.8	3.7	4.8	7.3	n/a ^[4]	n/a ^[4]	n/a ^[4]	n/a ^[4]
2E2-S	200	1.5	3.7	7.3	9.2	14.7	n/a ^[4]	n/a ^[4]	n/a ^[4]	n/a ^[4]
5E2-S	500	3.7	9.2	18.3	22.7	36.7	n/a ^[4]	n/a ^[4]	n/a ^[4]	n/a ^[4]
1E3-S	1,000	7.3	18.3	36.7	43.8	73.3	n/a ^[4]	n/a ^[4]	n/a ^[4]	n/a ^[4]
2E3-S	2,000	14.7	36.7	73.3	84.3	146.7	n/a ^[4]	n/a ^[4]	n/a ^[4]	n/a ^[4]
5E3-S	5,000	36.7	91.7	183.3	210.7	366.7	n/a ^[4]	n/a ^[4]	n/a ^[4]	n/a ^[4]
1E4-S	10,000	73.3	183.3	366.7	421.4	733.3	n/a ^[4]	n/a ^[4]	n/a ^[4]	n/a ^[4]

[1] Flow values in table are valid only when critical flow is established.

[2] When volumetrically based mass flow units with reference temperatures other than 0°C are used, flow values will generally be higher; the flow values for a given molbloc and upstream pressure are approximately 7% higher when expressed in slm at 20°C. Flow values at a given pressure may vary by up to ± 2% due to flowpath machining tolerances.

[3] Minimum upstream pressure to achieve critical flow with atmospheric pressure (approximately 100 kPa) downstream of molbloc-S (no vacuum).

[4] Operation in this gas is limited to lower pressures due to the gas vapor pressure.

Table 24: O2. molbloc-S Flow in Oxygen at Various molbloc Upstream Pressures

Oxygen Ratio = 0.935 O2		molbloc-S MASS FLOW RATE (slm @ 0 °C) WHEN molbloc-S UPSTREAM PRESSURE IS:[1][2]								
DESIGNATOR	K _F [sccm/ kPa]	20 kPa (3 psia)	50 kPa (7 psia)	100 kPa (15 psia)	Minimum without vacuum ⁽³⁾	200 kPa (30 psia)	500 kPa (70 psia)	700 kPa (100 psia)	1.2 MPa (174 psia)	2 MPa (290 psia)
1E1-S	10	0.2	0.5	0.9	1.9	1.9	4.7	6.5	11.2	18.7
2E1-S	20	0.4	0.9	1.9	3.4	3.7	9.4	13.1	22.5	37.4
5E1-S	50	0.9	2.3	4.7	7.3	9.4	23.4	32.7	56.1	93.5
1E2-S	100	1.9	4.7	9.4	14.4	18.7	46.8	65.5	112.3	187.1
2E2-S	200	3.7	9.4	18.7	26.4	37.4	93.5	131.0	224.5	374.2
5E2-S	500	9.4	23.4	46.8	63.8	93.5	233.9	327.4	561.3	935.4
1E3-S	1,000	18.7	46.8	93.5	120.4	187.1	467.7	654.8	1,122.5	1,870.8
2E3-S	2,000	37.4	93.5	187.1	231.9	374.2	935.4	1,309.6	2,245.0	3,741.7
5E3-S	5,000	93.5	233.9	467.7	556.6	935.4	2,338.5	3,274.0	5,612.5	9,354.2
1E4-S	10,000	187.1	467.7	935.4	1,113.1	1,870.8	4,677.1	6,547.9	11,225.0	18,708.3

[1] Flow values in table are valid only when critical flow is established.

[2] When volumetrically based mass flow units with reference temperatures other than 0°C are used, flow values will generally be higher; the flow values for a given molbloc and upstream pressure are approximately 7% higher when expressed in slm at 20°C. Flow values at a given pressure may vary by up to ± 2% due to flowpath machining tolerances.

[3] Minimum upstream pressure to achieve critical flow with atmospheric pressure (approximately 100 kPa) downstream of molbloc-S (no vacuum).

1.2.4.2.3 molbloc-S Dimensions

	molbloc-S SIZE [mm(in.)]				
	1E2-S AND LOWER	2E2-S THRU 1E3-S	2E3-S	5E3-S	1E4-S
A	48.0 (1.89) SQ	48.0 (1.89) SQ	48.0 (1.89) SQ	80.0 (3.15) SQ	80.0 (3.15) SQ
B	24.0 (0.94)	24.0 (0.94)	24.0 (0.94)	40.0 (1.57)	40.0 (1.57)
C	48.0 (1.89) SQ	48.0 (1.89) SQ	48.0 (1.89) SQ	80.0 (3.15) SQ	80.0 (3.15) SQ
D	80.0 (3.15)	80.0 (3.15)	80.0 (3.15)	176.0 (6.93)	176.0 (6.93)
E	28.0 (1.10)	28.0 (1.10)	28.0 (1.10)	44.0 (1.73)	44.0 (1.73)
F	167.5 (6.59)	171.0 (6.73)	175.0 (6.89) [1]	299.7 (11.80) [1]	331.0 (13.03) [1]
G	KF16 FLANGE	KF16 FLANGE	KF16 FLANGE	KF40 FLANGE	KF40 FLANGE
H	100.0 (3.94)	84.0 (3.31)	84.0 (3.31)	154.0 (6.06)	154.0 (6.06)
I	128.0 (5.04)	128.0 (5.35)	128.0 (5.35)	236.0 (9.29)	236.0 (9.29)
J	73.0 (2.87)	73.0 (2.87)	73.0 (2.87)	106.0 (4.17)	106.0 (4.17)
K	167.5 (6.59)	171.0 (6.73)	171.0 (6.73)	290.0 (11.42)	290.0 (11.42)
L	¼" VCR Male[2]	½" VCR M[2]	½" VCR M[2]	KF25 FLANGE[2]	KF25 FLANGE[2]

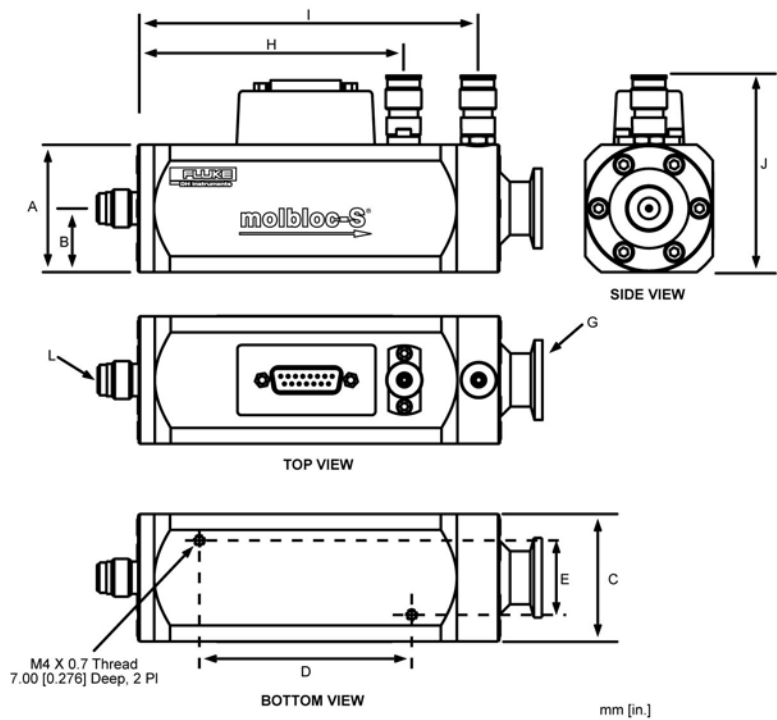

[1] On some molbloc-S elements, the venturi nozzle extends beyond the molbloc downstream flange, making the overall length dimension, F, longer than the fitting length dimension, K. The nozzle overhang may interfere with some molbloc-S downstream connections or the connection of a blank off cap for leak testing, so a 40 mm diameter ISO-KF nipple is supplied with 5E3-S and 1E4-S molblobs.

[2] Default connector type is listed. Additional upstream connector options may be available. Contact your FLUKE Sales Representative for details.

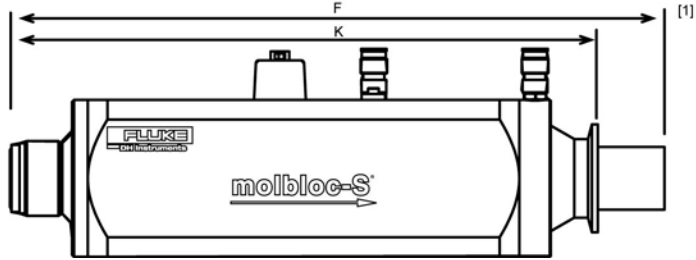

1.2.5 Front and Rear Panels

1.2.5.1 Front Panel

The front panel assembly provides a 2 x 20 vacuum fluorescent display, a membrane keypad for local user interface and a SOFT ON/OFF key.

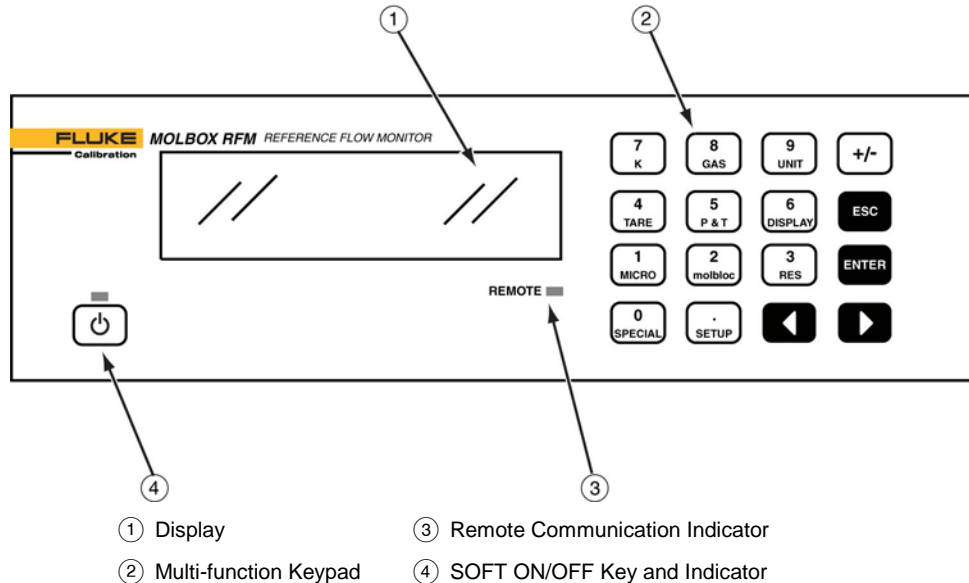

Figure 2. molbox RFM Front Panel

1.2.5.2 Rear Panel

The rear panel assembly provides pressure and electrical connections to a molbloc mass flow element, communications interfaces and the power connection module.

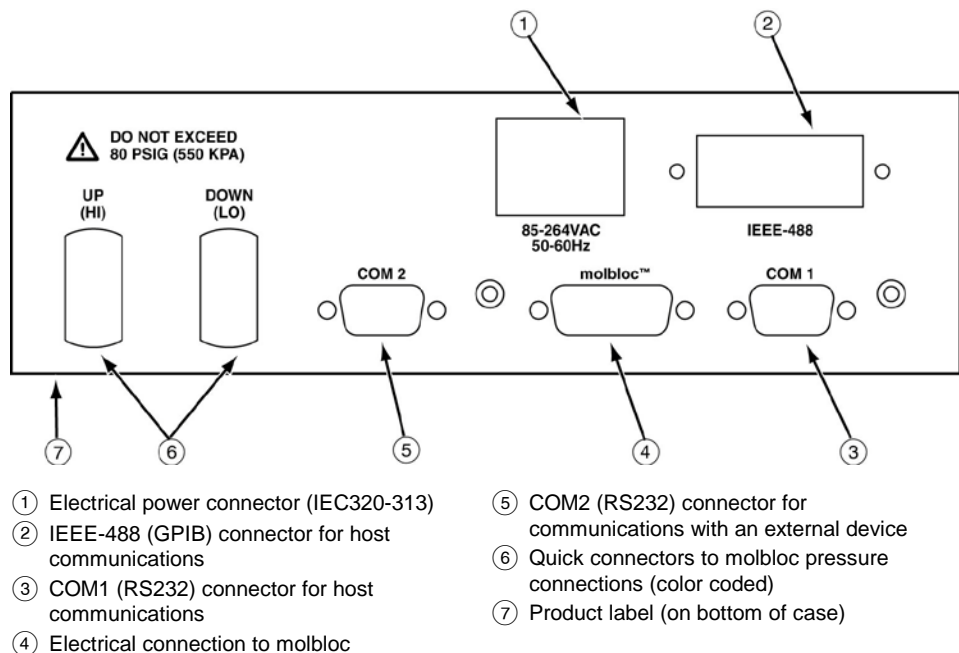

Figure 3. molbox RFM Rear Panel

2. Installation

2.1 UNPACKING AND INSPECTION

2.1.1 Removing From Packaging

molbox RFM is delivered, along with its standard accessories, in a corrugated container with polyurethane inserts to hold it in place.

Remove the molbox RFM and its accessories from the shipping container and remove each element from its protective plastic bag.

2.1.2 Inspecting Contents

Check that all items are present and have NO visible damage.

A molbox RFM includes:

Table 25. molbox RFM Parts List

DESCRIPTION		PART #
molbox RFM Reference Flow Monitor		3078349
Report of Calibration		3152121
ACCESSORIES, INCLUDING:		
1	Operation and Maintenance Manual	3152156
1	Power Cord, 2.3m (7.5 ft.)	3133781
1	Set of (2) molbox to molbloc pressure connecting tubes, 1 m (3.3 ft.)	3069560*
1	molbox to molbloc electrical/data connection cable, 1.8 m (6 ft.)	3068683
2	straight through quick connector stem	3068652**
1	General Accessories CD (white) (Important: Includes system support software and documentation.)	3139043

* 1.8m. (6 ft.) molbox to molbloc pressure connecting tubes are available as P/N 3070259

** Equivalent to Swagelok P/N SS-QM2-S-200

2.2 Site Requirements

Install molbox RFM on any stable surface at a convenient height. The front feet are extendible so that the unit can be inclined for easier viewing.

The molbox RFM can also be mounted in a standard 19-in. rack mount using the optional rack mount kit (P/N 3069903). For additional information, contact your **Fluke Calibration** Sales Representative.

When installing molbox RFM, consideration should be given to where the molbloc flow measuring element and associated hardware will be located. molbox RFM may be placed on a shelf or cart at a different height than the molbloc, but the distance between the molbloc and

molbox is limited by the length of the cable and pneumatic lines connecting them. If you will locate the molbox at a different height than the molbloc, the small errors that would be associated with the difference in pressure can be removed using the molbox RFM head correction (see Section 3.6.8).

If the molbloc/molbox system is being used to calibrate other devices (DUTs), the molbloc may need to be connected upstream or downstream of the DUT to operate within the pressure limits of the molbloc's calibration type (see Sections 1.2.4.1.2, 2.2.4.2.2) and to accommodate the pressure requirements of the DUT. See the molbloc's Calibration Report to determine the calibration type of the molbloc you are using.

If the molbloc is connected upstream of the DUT, it is important to supply the molbloc with a stable regulated gas source. The volume present between the molbloc and the device to be calibrated should be minimized for low flows.

In some cases, molbloc-S is used with a vacuum source downstream to reduce the pressure at which critical flow is reached. Consider the placement of the vacuum pump and connections. Generally, a large vacuum pump is needed that should be isolated from the work area due to noise and oil vapor considerations. If the vacuum pump and/or vacuum kit was purchased from **Fluke Calibration**, see the instruction sheets and/or manuals that are included with the hardware.

Optional molstics are offered for mounting molbloccs. They provide a convenient means of addressing supply regulation, filtering and interconnection issues with high quality, configured hardware. For additional information, contact your **Fluke Calibration** Representative.

⚠ Caution

If a DUT is located upstream of the molbloc and is contaminated, contaminants may flow from the DUT to the molbloc and alter the molbloc calibration. If the DUT must be connected upstream of the molbloc, be sure it is clean before flowing and consider installing a filter between the DUT and the molbloc.

2.3 Initial setup

2.3.1 Preparing for Operation

To prepare molbox RFM for check out and operation:

- ❶ Remove the plastic caps from the molbox RFM rear panel pressure connections.
- ❷ Remove the protective plastic sheet from the front panel display.
- ❸ Familiarize yourself briefly with the front and rear panels (see Section 1.2.5).
- ❹ Follow the steps described in Sections 2.3.2 to 2.3.6

2.3.2 Power Connection

Connect the power cable supplied to molbox RFM and to a power source. Power requirements are 85 to 264 VAC, 50 to 60 Hz, 22 VA max. consumption.

Note

molbox RFM is always powered and active when power is supplied through the rear panel power connector. The front panel ON/OFF key controls a SOFT ON/OFF (see Section 3.3.3).

2.3.3 molbox RFM to molbloc Connection

There are two pressure connections (upstream and downstream) and one electrical/data connection between molbox RFM and a molbloc.

For the pressure connections, use the molbox RFM to molbloc pressure tubes (P/N 3069560) supplied with the molbox RFM. Following the color coding on the pressure lines, connect the upstream (HI) molbox RFM rear panel quick connector to the upstream port of the molbloc and the downstream (LO) quick connector to the downstream port. Push firmly on the quick connectors until they click into place to assure that the connection is properly completed.

For the electrical/data connection, use the molbox to molbloc electrical/data connection cable (P/N 3068683). Connect the cable to the molbloc and then to molbox RFM rear panel connector labeled "molbloc".

Caution

Avoid making molbloc electrical connections to molblocs while molbox RFM is plugged in. Damage to the molbloc EEPROM may result (see Section 5.5.5)

2.3.4 GAS Supply And Flowpath Connections

Connect a gas supply to the molbloc. Gas supply requirements are:

- The gas supply must be clean and dry (especially free from oil and particulates) to avoid contaminating the molbloc.
- For correct measurements, the gas must be of the same species as that selected by the molbox RFM GAS function (see Section 3.4.2). Gas purity affects the measurement uncertainty of flow measurements as molbox RFM uses the thermodynamic properties of the flowing gas in its flow calculations. Generally, gases with purity of 99.9 % or better are used for molbloc measurements. Except when using ambient air with molbloc-S, the test gas should be free of any humidity (dew point less than – 40 °C).
- If the molbloc is connected upstream of the DUT, the supply pressure must be regulated and stable within the limits of the molbloc-L pressure dependent calibration type (see Section 1.2.4.1.2) or molbloc-S calibration type (see section 1.2.4.2.2). If the molbloc is connected downstream of the DUT, use regulators and valves to make sure that the pressure that is delivered to the molbloc will be within the limits of the molbloc calibration type.
- Care should also be taken to make sure that the pressure and flow supplied to the molbloc are always low enough to avoid over pressuring the molbox RFM RPTs (see Sections 1.2.2, 3.1.6). If a DUT upstream of the molbloc is operated at high pressure, a pressure reducing regulator should be connected between the DUT and the molbloc to ensure that even momentary high pressure spikes do not reach the molbox RPTs.

Caution

- **The gas supplied to the molbloc should be clean and dry. Contamination of the molbloc flow passage with liquids, particulates or any other matter will alter the molbloc calibration and can lead to out of tolerance flow measurements.**
- **NEVER connect a pressure source to the molbloc that is greater than the overpressure limit of your molbox RFM. molbox RFM overpressure limit is 660 kPa absolute/560 kPa gauge (95 psia/80 psig). Overpressure can damage the molbox RFM internal RPTs (see Section 1.2.2, 3.1.6).**

If you are using a Fluke Calibration molstic: Install the molbloc into the molstic and connect a gas supply following the molstic instruction sheet or manual. The flow through the molbloc must be in the direction of the arrow engraved on the molbloc.

If you are NOT using a Fluke Calibration molstic: Connect a gas supply to the molbloc according to the *Recommendations for molbloc Installation* instruction sheet, Fluke document #3152446, and the pressure limits of the molbloc calibration type. A valve should be installed between the pressure supply and the molbloc to allow flow to the molbloc to be interrupted. The flow through the molbloc must be in the direction of the arrow engraved on the molbloc.

Adaptor kits are available from **Fluke Calibration** to make connections from the molbloc or molstic fittings to other common connector types. Ask your **Fluke Calibration** Sales Representative about your specific adaptor requirements.

Caution

Operating at pressures other than those of the molbloc-L pressure dependent calibration type (see Section 1.2.4.1.2) or molbloc-S calibration type (see Section 1.2.4.2.2) may result in out of tolerance flow measurements. Refer to the molbloc Calibration Report to determine its calibration type.

2.3.5 Vacuum Supply (molbloc-S only)

In some cases molbloc-S is operated with a vacuum downstream of the molbloc to reduce the back pressure so that critical flow can be reached at a lower upstream pressure (see Section 3.1.2).

There is no lower limit to the pressure that may safely be applied to molbox RFM RPTs.

If you are using Fluke Calibration supplied downstream vacuum connect kit and vacuum pump: Install the kit and pump following the supplied instruction sheet or manual. Carefully follow the pump manufacturer's recommendations for pump operation.

If you are NOT using Fluke Calibration supplied downstream vacuum connect kit and vacuum pump: Carefully evaluate vacuum pump specifications to be sure that the vacuum source available has the pumping speed necessary to safely handle the planned flows and to maintain low enough pressure at planned flow rates.

Be sure to provide facilities to avoid flowing into the pump when the pump is not ON as this will cause pressure to build up on the pump and may damage it. Normally, a shut-off valve should be included between the pump and the molbloc-S.

It is preferable to install a check valve with very low cracking pressure between the molbloc and the vacuum shut-off valve.

Adaptor kits are available from **Fluke Calibration** to make connections from the molbloc or molstic fittings to other common connector types. Ask you Fluke Calibration Sales Representative about your specific adaptor requirements.

Caution

Operating at pressures other than those of the molbloc-S calibration type may result in out of tolerance flow measurements (see Section 1.2.4.2.2). Refer to the molbloc Calibration Report to determine its calibration type.

2.3.6 Communications Connections

If molbox RFM is being interfaced to a computer, connect an RS232 cable to molbox RFM COM1 or an IEEE-488 cable (cables not supplied) to the molbox RFM IEEE-488 interface. Configure the interface (see Section 3.6.6).

2.4 Power UP and Verification

2.4.1 Power UP

Connect the molbox RFM power cable to an electric supply of 85 to 264 VAC (47 to 440 Hz). Observe the front panel display as molbox RFM initializes, error checks, calibrates its internal ohmic measurement system and goes to the main run screen (see Section 3.2). The top left side of the main run screen should display a flow value near zero or **<BPR HI>**. If **<NO BLOC>** is displayed, molbox RFM has not been able to identify a molbloc connection and load molbloc information. Verify that a valid molbloc is properly connected (see Section 2.3.3) and press **[SETUP]**, **<4molbloc>** to load the molbloc data. If molbox RFM is still unable to identify a molbloc, the molbloc may require reloading of EEPROM information or molbox RFM may require repair.

If the molbox RFM fails to reach the main run screen: Service may be required. Record the sequence of operations and displays observed and contact a **Fluke Calibration** Authorized Service Provider (see Section 7.2).

Note

molbox RFM is always powered and active when power is supplied through the rear panel power connector. The front panel ON/OFF key controls a SOFT ON/OFF only (see Section 3.1.4).

2.4.2 Check Proper Pressure Measurement Operation

Check that the molbox RFM pressure measurements are operating properly. Proceed as follows:

- ❶ Connect the molbloc to the molbox RFM (see Section 2.3.3).
- ❷ Shut off the gas supply to the molbloc and open one or both molbloc ends to atmospheric (ambient) pressure.
- ❸ Press **[P&T]** and observe the display of the pressure measured by the upstream and downstream absolute RPTs. Observe the upstream and downstream pressures (see Section 3.4.5). These should indicate current atmospheric pressure and be in agreement within ± 0.5 kPa (0.1 psi). If the two readings disagree by more than ± 0.5 kPa (0.1 psi), one or both RPTs may be out of calibration and service may be required. A difference in the RPT readings could also indicate that there is some flow through the molbloc. Check the flowpath valve or disconnect the molbloc to ensure that there is actually no flow.
- ❹ If the molbox RFM is equipped with the microrange option, and the option is currently active, the bottom line left side of the display is **<mDP>**. Observe the differential pressure value following this indication (see Section 3.4.5). It should be $0, \pm 50$ Pa (0.004 psi). If the indication is different from zero by more than ± 50 Pa (0.004 psi), the microrange differential RPT may be out of calibration and service may be required. Again, a non-zero differential pressure could indicate an unexpected flow through the molbloc.
- ❺ Press **[ESCAPE]** to return to the main run screen.

2.4.3 Check Proper Temperature Measurement Operation

Check that the molbox RFM temperature measurement is operating properly. Proceed as follows:

- ❶ Connect a molbloc to the molbox RFM (see Section 2.3.3).
- ❷ From the molbox RFM main run screen, press **[P&T]** twice to arrive at the temperature display screen. Observe the temperature readings of the two molbloc PRTs

(see Section 3.4.5). If the molbloc has been in a stable temperature environment for 30 to 60 minutes, the temperature indications should be roughly ambient temperature and the two indications should agree within ± 0.2 °C. If the two readings disagree more than ± 0.2 °C, there may be a problem with the molbloc or the molbox RFM TEMPERATURE MEASUREMENT function and service may be required.

2.4.4 Leak Check

It is recommended that a new molbox RFM be leak checked at start-up to assure that no internal leaks developed during shipping and handling. Run the molbox RFM on-board INTERNAL LEAK CHECKING function (see Section 3.4.5).

2.4.5 Check/Set Security Level

molbox RFM has a security system based on user levels. By default, the security system is set to “low”, which includes certain access restrictions, and there is no password required to change the security level (see Sections 3.6.2). As part of the molbox RFM startup, set your desired security level and a password.

Caution

molbox RFM is delivered with the security level set at low to avoid inadvertent altering of critical internal settings but with access to changing security levels unrestricted. It is recommended that the low security level be maintained at all times and password protection be implemented if control over setting of security levels is desired.

2.5 Additional Precautions to Take Before Making Flow Measurements

Before using molbox RFM to make meaningful flow measurements, consider the following:

- Be sure that the gas pressure connected to the molbloc is not great enough to overpressure the molbox RFM internal RPTs.
- For molbloc-L operation, the pressure measuring RPTs should be *tared* at the operating line pressure (see Section 3.4.4.1).
- Operating pressure should be within the limits of the molbloc calibration type (see Sections 1.2.4.1.2. and 1.2.4.2.2).
- The gas type selected should be the gas flowing through the molbloc (see Section 3.4.2).
- For best accuracy, the gas type should be a gas with which molbloc has been calibrated. See the molbloc Calibration Report or press **[SETUP]**, **<4molbloc>**, **[ENTER]** to see if the gas is included in the molbloc calibration gas list (see Section 3.5.4).
- Do not supply a gas or connect a device under test upstream of the molbloc that may contaminate the molbloc.
- Be sure the flow unit of measure you are using is correct. Many different types of flow units of measure are commonly used. Before selecting a unit of measure, familiarize yourself with Section 3.4.3 thoroughly.
- Troubleshooting: For information on typically encountered start-up and operational issues, see Section 6.

2.6 Short Term Storage

The following is recommended for short term storage of molbox RFM:

- Vent the molbox RFM pressure ports.
- Disconnect the power supply.

When molbox RFM will NOT be used for some time, it may be left powered. Use the SOFT ON/OFF key to turn OFF the display.

Notes

3. Operation

3.1 General Operating Principles

3.1.1 molbloc-L and molbloc-S operation

molbox RFM operates somewhat differently depending on whether a molbloc-L or molbloc-S is connected to it. molbloc-L and molbloc-S operation use different displays and flow calculations and some menu items are present for only one type of molbloc.

Most molbox RFM settings, such as gas, units, K factor, etc., are common to both molbloc-L and molbloc-S operation. Changes made to these settings while operating one type of molbloc will still be in effect when the other type of molbloc is connected. The only setting that is used for both molbloc types but is stored independently for each type is tare. See section 3.4.4.1 for details on the tare function.

Several of the molbox RFM screen displays and functions described in this section are different for molbloc-L and molbloc-S operation. Where the differences are major, the description of these functions is divided into two parts.

3.1.2 molbloc-S BPR Limits

To make flow measurements within predictable measurement uncertainty limits with a molbloc-S flow element, critical (sonic) flow conditions must be present. Critical flow exists when the gas velocity reaches the local speed of sound at the throat of the molbloc-S venturi nozzle.

molbox RFM uses the back pressure ratio, or BPR (the ratio of the molbloc-S downstream absolute pressure to the upstream absolute pressure) to determine whether the flow is critical. For venturi nozzles in general, the BPR must remain below a certain value for critical flow to exist. Commonly accepted practice for typical venturi nozzle use suggests that this limiting BPR value, or “choking ratio”, is approximately 0.5. That is, the absolute pressure downstream of the nozzle must be less than one half of the absolute pressure upstream of the nozzle. Empirical study of the venturi nozzles used in molbloc-S shows that the actual choking ratio, or maximum BPR for critical flow, varies between about 0.4 and 0.9 as a function of the Reynolds number (Re) over which the molblocs are used. molbox RFM continually calculates Re during flow measurement and can monitor the BPR to ensure that it does not exceed the choking ratio at the current Re conditions. molbox RFM uses a conservative BPR limit to indicate to the user when the BPR approaches the choking ratio, to ensure that flow measurements are only made under “safe” critical flow conditions. molbox RFM includes features to measure BPR, automatically alert the operator when the BPR is too high and prevent measurements when flow is not critical (see Sections 3.1.3.2, 3.4.4.5, 3.6.9).

Maintaining a sufficiently low BPR must be considered by molbloc-S users when selecting molbloc-S sizes and hardware setups to use for flow measurements. For example, if a molbloc-S will be used with atmospheric pressure downstream, then the molbloc can only be used over a range of upstream pressures starting at the maximum pressure for its calibration type down to a minimum pressure value at which the BPR becomes equal to the BPR limit calculated by molbox RFM. Since mass flow through molbloc-S is proportional to the upstream absolute pressure, the flow range for the molbloc in this application is defined by this BPR limit. To maximize the range of a molbloc-S element, a vacuum pump can be connected downstream to reduce the downstream pressure while flowing. When the downstream pressure is kept sufficiently low, the upstream pressure, and thus the mass flow

rate, can be adjusted all the way down to the minimum value for the molbloc's pressure dependent calibration type without being limited by the BPR value.

Depending on the placement of the molbloc-S in relation to the DUT and other hardware, and the availability and capacity of a vacuum pump that may be used, the molbloc-S downstream pressure will vary in different applications. Calculating Re for different molbloc-S sizes and flow rates, and estimating the choking ratio (maximum BPR limit) as a function of Re is somewhat complex, so Table 26 is offered to give the minimum flow that can be achieved with each molbloc-S size, without exceeding molbox BPR limits, when the molbloc-S downstream pressure is known: In actual operation, molbox RFM calculates the Re and BPR ratio and provides an indication of whether the BPR is adequate for measurements to be made.

Table 26: Minimum molbloc-S Critical Flow (slm) in Nitrogen at Various molbloc-S Downstream Pressures

molbloc-S DESIGNATOR	N2 MINIMUM molbloc-S CRITICAL FLOW [SLM @ 0°C] WITH MOLBLOC DOWNSTREAM PRESSURE OF: ^[1]										
	≤5 kPa (0.7 psia)	10 kPa (1.5 psia)	25 kPa (3.5 psia)	50 kPa (7 psia)	100 kPa (15 psia)	110 kPa (16 psia)	125 kPa (18 psia)	150 kPa (22 psia)	200 kPa (30 psia)	250 kPa (36 psia)	300 kPa (44 psia)
1E1-S	0.2 ^[2]	0.4	0.9	1.1	1.8	2.0	2.2	2.4	2.8	3.5	4.2
2E1-S	0.4 ^[2]	0.7	1.6	1.8	3.2	3.5	3.7	4.2	5.6	7.0	7.6
5E1-S	1 ^[2]	1.7	3.4	4.7	7.7	8.4	9.4	11	14	17	20
1E2-S	2 ^[2]	3.4	5.9	8.4	15	16	18	21	27	33	38
2E2-S	4 ^[2]	5.9	9.8	16	28	31	34	40	51	63	74
5E2-S	10 ^[2]	12	20	37	67	72	80	95	122	149	179
1E3-S	20 ^[2]	20 ^[2]	39	69	129	139	154	184	239	294	349
2E3-S	40 ^[2]	40 ^[2]	73	131	248	268	298	358	468	578	687
5E3-S	100 ^[2]	100 ^[2]	173	317	596	646	746	871	1 145	1 420	1 694
1E4-S	200 ^[2]	200 ^[2]	347	615	1 173	1 273	1 442	1 741	2 240	2 789	3 338

[1] When volumetrically based mass flow units with reference temperatures other than 0 °C are used, flow values will generally be higher; for example, the flow values for a given molbloc and upstream pressure are approximately 7 % higher when expressed in slm @ 20 °C. Flow values at a given pressure may vary by up to 2 % due to flowpath machining tolerances.

[2] Limited by 20 kPa minimum calibration pressure rather than back pressure ratio

3.1.3 Flow Ready/Not Ready Indication

The character to the left of the measured flow on the MAIN run screen provides a flow *Ready/Not Ready* indication. This indication is intended to provide the user with a clear and objective indication of when a stable flow has been achieved.

Ready <>* is indicated when the current stability (rate of change) of flow is less than the stability limit. The user can set the stability limit (see Section 3.5.5). The *Ready/Not Ready* indication is often used when comparing molbox RFM and a test device to help determine when steady state flow conditions are present so that a valid comparison reading can be made.

In addition to the conditions listed in sections 3.1.3.1 and 3.1.3.2 molblobs that have named calibration support will flash the flow display and indicate a Not Ready condition when the measured flow exceeds the calibrated flow range by 5% or the measured upstream pressure exceeds the calibrated pressure range by 10 kPa above the maximum pressure or 10 kPa below the minimum pressure. The downstream pressure is used when a molbloc-L downstream calibration is active.

3.1.3.1 molbloc-L Operation

In molbloc-L operation, the *Ready/Not Ready* indication also helps guard against using molblocs above their valid range by monitoring the Reynolds number of the flow. If the Reynolds number of the current flow exceeds 1 300, the *Ready* (<*>) indicator flashes. The current Reynolds number value can be viewed using **[P&T]** (see Section 3.4.5). If molblocs are used within the pressure and flow range limits for the flowing gas and the pressure dependent calibration type (see Section 1.2.4.1.2), a Reynolds number of 1 200 will never be exceeded (1 300 is used as the warning limit to allow for individual molbloc differences).

Ready/Not Ready character indications are:

- <*> Flow *Ready* (stable).
- <*> (Flashing): Reynolds number > 1 300.
- <↓> Flow *Not Ready* (unstable and decreasing).
- <↑> Flow *Not Ready* (unstable increasing).
- <P> [Alternate] Flow *Not Ready*, *flow flashes* (pressure exceeds calibrated pressure range by 10kPa)
- <F> Flow *Not Ready*, *flow flashes* (flow exceeds calibrated max flow by 5%)

3.1.3.2 molbloc-S Operation

In molbloc-S operation, the *Ready/Not Ready* indication is also used to warn the user when the BPR (back pressure ratio) is too high to ensure critical flow (see Sections 3.1.2). When the BPR is beyond the choking limit, molbloc-S flow measurements may not be valid and the *Ready* indicator becomes <P>. The *Ready/Not Ready* indicators based on flow stability are also used in molbloc-S operation, but the <P> indicator takes priority over other indicators.

Ready/Not Ready character indications are:

- <*> Flow *Ready* (stable).
- <↓> Flow *Not Ready* (unstable and decreasing).
- <↑> Flow *Not Ready* (unstable increasing).
- <P> Flow *Not Ready* (BPR high / sub-critical flow)
- <P> [Alternate] Flow *Not Ready*, *flow flashes* (pressure exceeds calibrated pressure range by 10kPa)
- <F> Flow *Not Ready*, *flow flashes* (flow exceeds calibrated max flow by 5%)

3.1.4 Soft [On/Off] Key

molbox RFM is equipped with a SOFT **[ON/OFF]** key and indicator LED on the bottom left hand corner of the front panel. The purpose of the SOFT ON/OFF key is to put molbox RFM into a dormant mode in which the display is turned OFF but power is still supplied and OVERPRESSURE functions are still active. When molbox RFM is ON, the ON/OFF indicator is ON continuously.

When molbox RFM is SOFT OFF, the ON/OFF indicator blinks every 5 seconds.

When molbox RFM is SOFT OFF, receiving a remote command turns it ON.

When molbox RFM is SOFT OFF, an overpressure conditions turns it ON.

3.1.5 Microrange option (Optional)

The molbox RFM offers a microrange option to improve molbloc-L flow measurement specifications below 10 % of full scale of the molbloc being used (see Section 1.2.4.1.1) for any range from 1E1-L thru 3E4-L. Due to the low differential pressure of a 1E5-L, the microrange option is required to use this range of molbloc within the standard flow measurement specification. The microrange option is only active during molbloc-L operation and has no effect on molbloc-S operation or specifications.

The microrange option includes a low differential pressure RPT to improve the measurement of differential pressure across the molbloc below 12.5 kPa (1.8 psi). A three-way valve and on-board logic automatically put the low differential RPT into and out of service. This allows it to be used as the source of differential pressure values whenever differential pressure is under 12.5 kPa (1.8 psi) and bypassed for protection from overpressure when differential pressure exceeds 13.5 kPa (2 psi) (see Figure 3).

With automatic microrange operation ON, the microrange option (if present) is used transparently to the operator to optimize flow measurement resolution and accuracy (see Section 3.4.7). With automatic microrange operation OFF, the microrange option is not used and all measurements are made using the upstream and downstream absolute RPTs only.

When the type of molbloc connected to molbox RFM is changed from molbloc-L to molbloc-S, or molbox RFM power is cycled, the last state of the microrange option (ON or OFF) is retained for molbloc-L operation.

The microrange option can also be controlled manually by pressing **[SPECIAL]** and selecting **<7micro>** (see Section 3.6.7).

The microrange indicator on the main run screen (see Section 3.4.7) indicates the status of the microrange option.

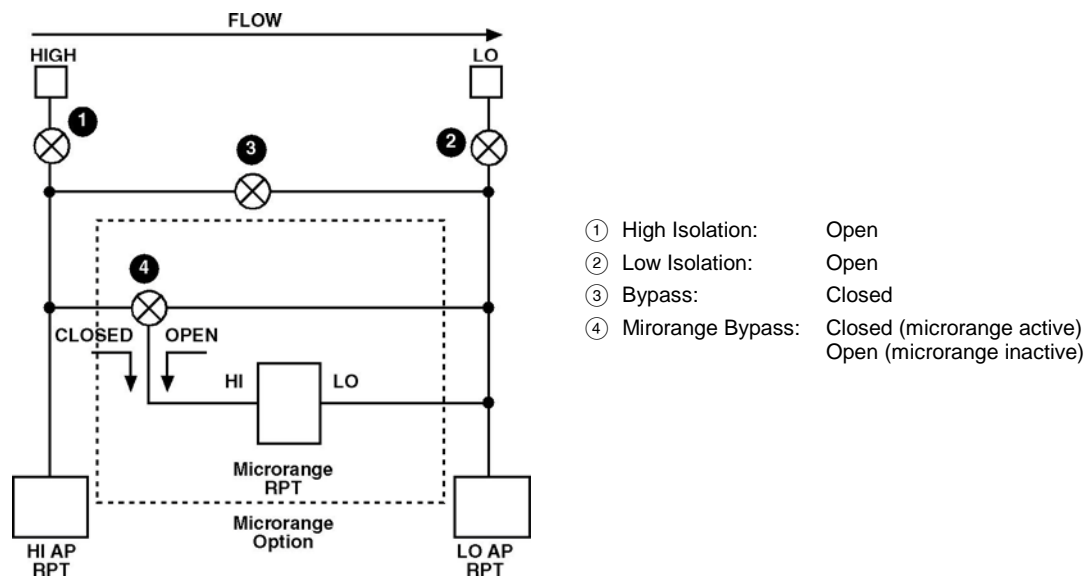

Figure 4. molbox RFM Internal Pneumatic Schematic – MICRORANGE OPTION RPT ACTIVE/INACTIVE

Note

- To determine if a molbox RFM is equipped with the microrange option, check the model number on the product label on the bottom of the molbox RFM case. If the model number includes a “-M”, the microrange option is installed.
- The microrange option is only active during molbloc-L operation. Mirorange has no effect on molbloc-S operation or measurement specifications.

3.1.6 Reference pressure transducer (RPT) overpressure

3.1.6.1 Upstream and Downstream Absolute RPTS

Every molbox RFM has two absolute RPTs, one measures molbloc upstream pressure, the other usually measures molbloc downstream pressure and may provide a second measurement of molbloc upstream pressure in molbloc-S operation. In normal operation, they are not used at pressures greater than **600 kPa absolute (87 psia)**.

Exposing the molbox RFM RPTs to pressures greater than the maximum operating pressure may damage them. molbox RFM has a system of warnings and alarms to protect itself from overpressure (see Section 3.6.3.1).

3.1.6.2 Differential RPT, Microrange Option

The microrange option low differential RPT has no overpressure warnings or alarms in normal operation. It is, to the extent possible, protected from overpressure automatically and transparently as it is put into and out of service using the molbox RFM on-board valving.

In *run calibration* operation (see Section 5.2.4.1), the microrange RPT has an OVERPRESSURE function whose operation is similar to the absolute RPT overpressure function (see Section 3.6.3). Overpressure occurs at about **13.7 kPa (2 psi)** differential.

When an overpressure condition occurs during *run calibration* of the microrange transducer, the display of microrange pressure indicates:

<p>Microrange RPT: OVERP! kPa [ENTER]</p>

Be sure the pressure conditions that caused the overpressure to occur have been cleared. Then press [ENTER] to reactivate the microrange RPT.

⚠ Caution

When using molbox RFM equipped with the microrange option, avoid very rapid pressurization of one molbloc port. Attempt to open flow isolation valves slowly. The microrange option low differential RPT is protected from overpressure automatically by internal valving. However, dumping pressure very rapidly on one port of the molbloc while the differential RPT is active could cause a very sudden surge in differential pressure that can overpressure it.

3.2 Main Run Screen

The molbox RFM MAIN run screen is its home display that is reached upon power up and from which other functions and menus are accessed. It is the top level of all menu structures. It indicates the current measured flow as well as a variety of additional information, if desired.

The appearance of the MAIN run screen differs depending on whether the active molbloc is a molbloc-L or a molbloc-S.

3.2.1 molbloc-L Operation

Some items in the molbloc-L MAIN run screen may change or flash at times, to indicate that certain limits are exceeded, as described in the text accompanying the following screen display:

1. **<*>** Ready/Not Ready indication: **<*>** when Ready (flashes if Reynolds number of the flow exceeds 1 300 or if flow was not ready for a full averaging period in AVERAGE display), **<↑>** (increasing) or **<↓>** (decreasing) indicating direction of flow rate evolution when Not Ready (see Section 3.1.3). May also display **<P>** or **<F>** if the calibrated pressure or flow range of the attached molbloc is out of range.
2. **<FLOWWW>**: Numerical value and sign of the flow measured by molbox RFM. Result of last flow averaging cycle if in AVERAGE display (see Section 3.4.6.2). Flashes if Reynolds number of the flow exceeds 1 300. Flashing also occurs when a named calibration is active and the flow exceeds the calibrated range by 5%, or the measured upstream pressure exceeds the calibrated pressure range by 10 kPa above the maximum pressure or 10 kPa below the minimum pressure. The downstream pressure is used when a molbloc-L downstream calibration is active. The field displays "PMODEL" when the pressure exceeds the molbox internal pressure model for the active calibration gas.

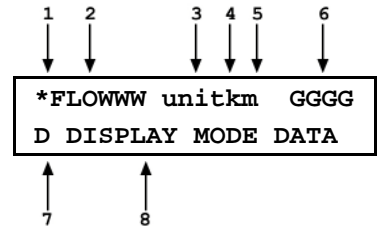

3. **<UNIT>**: Current flow unit of measure (see Section 3.4.3).
4. **<K>**: Indicates whether a gas correction factor (*K factor*) is currently being applied to the measured flow (see Section 3.4.1). **<K>** if a factor is being applied, blank if no factor is being applied. **<A>**: Indicates that a flow adjustment adder and/or multiplier is currently being applied to the measured flow using the ADJ function (see Section 3.5.3). **<A>** if ADJ is being applied, blank if no ADJ is being applied. **Alternating** When both ADJ and a K factor are applied, the indication alternates between **<K>** and **<A>** at each screen update.
5. **<m>**: Microrange option indicator (see Sections 3.4.7 and 3.6.7). Possible indications include:
 - Blank, NO character**: The microrange option is currently OFF or the molbox RFM is not equipped with the microrange option.
 - <m>**: **Automatic** microrange is ON (see Section 3.4.7).
 - <d>**: **Manual** microrange is ON and the differential pressure reading being used to calculate flow is coming from the microrange differential RPT (see Section 3.6.7).
 - <a> (flashing)**: **Manual** microrange is ON and the differential pressure reading being used to calculate flow is NOT coming from the microrange low differential RPT. It is the difference between the upstream and downstream absolute RPTs (see Section 3.6.7).
6. **<GGGG>**: Indicates the current molbox gas selection (see Section 3.4.2). This should be the gas that is flowing through the molbloc.
7. **<D>**: Indication of what is being displayed on the bottom line of the display as set by the DEVIATION function (see Section 3.4.6.6). Possible indications include:
 - <R>**: Current DISPLAY mode is RATE (see Section 3.4.6.1); or if **<n avg>** is in the bottom right hand corner of the display, current DISPLAY mode is "average" and this is the instantaneous reading AVERAGE screen (see Section 3.4.6.2).
 - <σ>** Current DISPLAY mode is AVERAGE (see Section 3.4.6.2).
 - <H>** Current DISPLAY mode is HI/LO (see Section 3.4.6.3).
 - <Σ>** Current DISPLAY mode is TOTAL (see Section 3.4.6.4).
 - <=>** Current DISPLAY mode is UNIT (see Section 3.4.6.5).
 - <D>** Current DISPLAY mode is DEVIATION (see Section 3.4.6.6).
 - <F>** Current DISPLAY mode is FREEZE (see Section 3.4.6.7).
 - Blank, No character** Current DISPLAY mode is CLEAN (see Section 3.4.6.8).
8. **<DISPLAY MODE DATA>**: Information displayed depends on current display mode (see Section 3.4.6).

Note

- When a number is too large to show in the allocated display space, molbox RFM displays <*****>.
- molbox RFM has a SCREEN SAVER function that causes the display to dim if NO key is pressed for 10 minutes. Pressing a key restores full power to the display. The screen saver activation time can be changed or screen saving can be completely suppressed (see Section 3.6.5.1).

3.2.2 molbloc-S Operation

As with molbloc-L there are limits on some of the conditions that may exist if the user expects to make accurate flow measurements with molbloc-S. The key condition that can be monitored is the back pressure ratio, or BPR, which determines whether critical flow through the molbloc is achieved (see Section 3.1.2).

When the BPR is in a “safe” region for critical flow measurements, the appearance of the MAIN run screen is identical to the MAIN run screen for molbloc-L operation (see Section 3.2.1). When the molbox RFM BPR limit is exceeded, there are two possible MAIN run screen indicators. A flashing flow value and unit indicate that the BPR limit has been exceeded. In this condition, the flow may not be critical and flow measurements should not be relied on to meet specifications. When the BPR limit is exceeded by a large margin, the flow is almost certainly not critical and the calculated value may be nonsensical, so the flow value is not shown and is replaced by <BPR HI>.

Note

When molbloc-S is in the BPR OFF mode (see Section 3.6.9), BPR is not monitored and invalid flow values may be displayed in the molbloc-S MAIN run screen with no indication that a the BPR value is high.

1. <*> Ready/Not Ready indication; <*> when Ready <↑> (increasing) or <↓> (decreasing) indicating direction of flow rate evolution when *Not Ready*; <P> when BPR is higher than choking limit. (see Section 3.1.2). May also display <P> or <F> if the calibrated pressure or flow range of the attached molbloc is out of range.
2. <FLOWWW>: Numerical value and sign of the flow measured by molbox RFM. Result of last flow averaging cycle if in AVERAGE display (see Section 3.4.6.2). Flashes if BPR is higher than the choking limit. If BPR exceeds the choking limit by a large margin, <BPR HI> replaces the flow value. The flow will flash when a named calibration is active and the flow exceeds the calibrated range by 5% or the measured upstream pressure exceeds the calibrated pressure range by 10 kPa above the maximum pressure or 10 kPa below the minimum pressure. The field displays “PMODEL” when the pressure exceeds the molbox internal pressure model for the active calibration gas.
3. <UNIT> Current flow unit of measure (see Section 3.4.3). Flashes if BPR is higher than the choking limit.
4. <K>: Same as molbloc-L (see Section 3.4.1).
5. <GGGG>: Indicates the current molbox gas selection (see Section 3.4.2). This should be the gas that is flowing through the molbloc. <AirW> indicates that air is selected and a humidity correction is being applied (see Section 3.4.2.2).
6. <D>: Same as molbloc-L (see Section 3.4.6).
7. <DISPLAY MODE DATA>: Information displayed depends on current display mode (see Section 3.4.6).

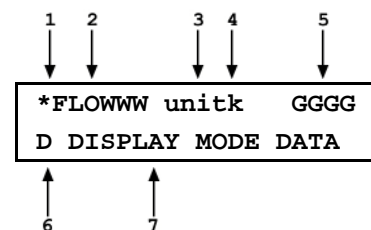

Note

- When a number is too large to show in the allocated display space, molbox RFM displays <*****>.
- molbox RFM has a SCREEN SAVER function that causes the display to dim if NO key is pressed for 10 minutes. Pressing a key restores full power to the display. The screen saver activation time can be changed or screen saving can be completely suppressed (see Section 3.6.5.1).

3.3 Manual Operation

molbox RFM is designed to offer the optimum balance between simple, intuitive operation and the availability of a wide variety of functions with a high level of operator discretion. The local operator interface is through the front panel's 2 x 20 character alpha-numeric display and a 4 x 4 multi-function keypad. Remote operation by RS232 or IEEE-488 interface is also available (see Section 4).

3.3.1 Keypad Layout and Protocol

Molbox RFM has a 4 x 4 keypad for local operator access to direct functions, function menus and for data entry.

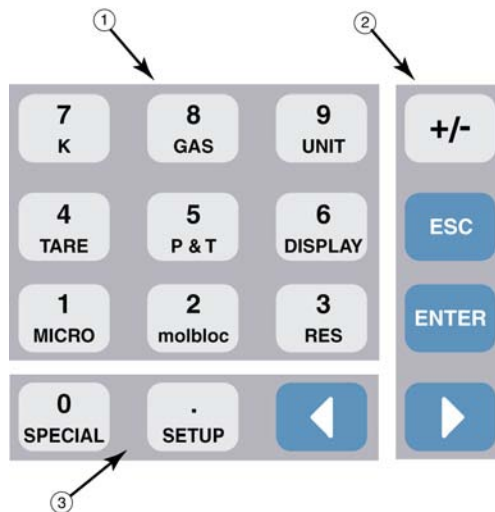

- ① **The Function/Data keys** allow very commonly used functions to be accessed directly from the MAIN run screen by a single keystroke. The name of the function is on the bottom half of the key (see Sections 3.3.4 and 3.4.) These keys enter numerical values when editing.
- ② **The Editing and Execution keys** are for execution, suspending execution, backing up in menus and editing entries
- ③ **The Menu/Data keys** provide access to function menus from the MAIN run screen. The menu name is on the bottom half of the key. The SETUP menu is for more frequently used functions. The SPECIAL menu is for less frequently used and internal functions. These keys enter numerical values when editing.

Figure 5. Keypad Layout

Pressing the **[ENTER]** key generally causes execution or forward movement in the menu tree.

Pressing the **[ESCAPE]** key generally allows movement back in the menu tree and/or causes execution to cease or suspend without changes being implemented. Pressing **[ESCAPE]** repeatedly eventually returns to the MAIN run screen. From the MAIN run screen, pressing **[ESCAPE]** allows momentary viewing of the molbox RFM identification screen.

Pressing the **[+/-]** key changes a numerical sign when editing. It also toggles through multiple screens when available.

Pressing the **[←]** and **[→]** keys allows reverse and forward cursor movement when editing data entry. These keys are also used to scroll through menu choices.

Menu selections can be made by pressing the number of the selection directly or by pressing **[←]** and **[→]** to place the cursor on the number of the desired selection and pressing **[ENTER]**.

Note

Some screens go beyond the two lines provided by the display. This is indicated by a flashing arrow in the second line of the display. Press **[←] and **[→]** to move the cursor to access the lines that are NOT visible or directly enter the number of the hidden menu choice if you know it.**

3.3.2 Sounds

molbox RFM is equipped with a variable frequency tone device to provide audible feedback and alarms. Sounds are used for the following indications:

Valid key press	Brief beep. Choice between three frequencies or NO sound is available (see Section 3.6.5.2).
Invalid key press	Descending two tone “blorp”. Choice of NO sound is available (see Section 3.6.5.2).
Totalizing time complete	Three, 2 second beeps (see Section 3.4.6.4).
Purge time complete	Three, 2 second beeps (see Section 3.4.4.2).
Near overpressure limit exceeded	Intermittent 1 second beeps (see Section 3.6.3).
Overpressure limit exceeded	5 second high frequency beep (see Section 3.6.3).

3.3.3 Soft [On/Off] Key

molbox RFM is equipped with a SOFT **[ON/OFF]** key and indicator LED on the bottom left hand corner of the front panel. The purpose of the SOFT ON/OFF key is to put molbox RFM into a dormant mode in which the display is turned OFF but power is still supplied and OVERPRESSURE functions are still active. When molbox RFM is ON, the ON/OFF indicator is ON continuously.

When molbox RFM is SOFT OFF, the ON/OFF indicator blinks every 5 seconds.

When molbox RFM is SOFT OFF, receiving a remote command turns it ON.

When molbox RFM is SOFT OFF, an overpressure conditions turns it ON.











3.3.4 Direct Function Keys Summary

Local operation of molbox RFM is through the front panel 4 x 4 pressure sensitive keypad. To minimize the use of multi-layered menu structures, the keypad numerical keys also provide direct access to the most commonly used functions. The function accessed is labeled on the bottom half of the each key. Direct function keys are active whenever molbox RFM is in its MAIN run screen. Table 27 summarizes the operation of the direct function keys. See corresponding manual sections for full detail on each direct function.

Note

It may be useful to keep a copy of Table 27, Summary of molbox RFM Direct Function Key Operations, near the molbox RFM, especially when first becoming acquainted with its operation.

Table 27. Summary of molbox RFM Direct Function Key Operations

DIRECT FUNCTION KEYS ARE ACTIVE FROM THE MAIN RUN SCREEN SEE CORRESPONDING MANUAL SECTIONS FOR FULL DETAIL	
	Menu of commonly used setup features including unit changes and stability setting.
	Menu of less frequently used internal functions and settings including preferences, resets, molbox calibration, remote interfaces, BPR (back pressure ratio) when using molbloc-S.
	Turn automatic microrange ON/OFF.
	Load the molbloc that is currently connected to molbox RFM. Use this to activate a new molbloc after a molbloc change or to view details on the molbloc that is currently in use.
	Set the resolution with which the measured flow and other values are displayed.
	Run the TARE, LEAK CHECK, PURGE, AutoZ and BPR functions.
	Display the current pressure measurements (first press). Display the current molbloc temperature measurements (second press). Display returns to the normal run screen (third press).
	Define the DISPLAY function for the second line of the molbox RFM display. Choices include rate, average, hi/lo, totalize, 2nd unit, deviation, freeze, clean.
	Set/change a DUT gas correction factor (K factor).
	Set flow measurement gas. This is also the key used to access and select named gas calibrations on a molbloc.
	Set flow measurement unit. Choice of units can be customized.

3.4 Direct Function Keys

3.4.1 [K]

○ PURPOSE

To cause the flow value calculated by molbox RFM to be multiplied by a factor, K. Generally used to apply a test device's gas correction factor used when a test device is calibrated with a gas other than its normal process gas.

○ PRINCIPLE

Frequently, when testing or calibrating a flow-measuring device, it is not possible to flow the gas with which that device will normally be operated (the **process gas**). This may be because the

process gas is toxic or corrosive or simply because it is not available or convenient to use. When the **process gas** cannot be used for calibration, it is common to use a different gas for testing or calibrating (the **calibration gas**). In this case, a factor representing the relationship between the **calibration gas** and the **process gas** for the test device may be applied so that the **calibration gas** simulates the **process gas**. The **calibration gas** that simulates the **process gas** is often called a **surrogate gas** for the **process gas**.

The relationship between a test device's **process gas** and **calibration gas** is frequently called a *K factor* or *gas conversion factor*. The factor's value depends on specific properties of the test device and determining the value is the responsibility of the device manufacturer.

For example, Silane (SiH₄) is a frequently used gas in semiconductor processing. SiH₄ is highly toxic and requires extensive handling precautions so it is not practical for use in calibration and testing. A major manufacturer of Mass Flow Controllers (MFCs) recommends that MFCs that are to be used with Silane be tested with Sulfur Hexafluoride (SF₆), a non-toxic, non-flammable gas, using a conversion factor of 0.970. In other words:

$$\text{SF}_6 \text{ flow} \times 0.970 = \text{equivalent SiH}_4 \text{ flow for the MFC}$$

The K function in molbox RFM allows a gas conversion factor to be entered by which flow values measured by molbox RFM will be multiplied. In this example, **0.970** would be entered as K so that the values indicated by molbox RFM when SF₆ is flowing through the molbloc simulate the flow of SiH₄ for that manufacturer's MFC.

When the K function is active, molbox RFM performs all of its flow calculations normally but multiplies the current flow value by the value of the K factor prior to displaying it.

The gas selected on molbox RFM which is displayed in the upper right corner of the molbox RFM display should always be the gas that is actually flowing through the molbloc.

Note

- *K factors* or *gas conversion factors* are based on the properties of the device being tested. Their availability and validity are the responsibility of that device's manufacturer. molbloc/molbox does not use factors or conversion coefficients between gases. Flow is calculated from molbloc characteristics and specific gas properties for each gas supported by molbox. The gas selected on molbox RFM (see Section 3.4.2) which is displayed in the upper right corner of the molbox RFM display should always be the gas that is actually flowing through the molbloc.
- If the K function and the ADJ function are both active, the ADJ adder and multiplier are first applied to the measured molbloc flow, then the result is multiplied by the K factor. This order of operations reflects the fact that the ADJ values are intended to represent an adjustment to be applied to the molbloc flow while measuring the *calibration gas* that is flowing, and the K factor is a correction related to gas effects on the device under test measurement (See Section 3.4.6).

○ OPERATION

To enable a *gas conversion factor* press **[K]** from any run screen. The display is:

K Factor?
1on 2off

If **<2off>** is selected, no conversion factor will be applied. If **<1on>** is selected, the next screen is:

K Factor:
1.00000

The value of the *gas conversion factor* can be edited as desired. Pressing **[ENTER]** returns to the MAIN run screen with the entered *K factor* active. **The letter <K> is always appended to the flow unit indication in the run screens when the K function is ON (e.g., sccmK).** A *K factor* value of 1 is handled as if the K function were OFF.

⚠ Caution

When the K function is ON, as indicated by a <K> following the current flow unit in the first line of the MAIN run screen, the current molbox RFM flow indication equals:

(flow as calculated by molbox RFM for the selected gas) x (the current K factor)

So the indicated flow is actually in error (biased) relative to the true flow through the molbloc by the value of the K factor. Care should be taken to ensure that the correct molbloc range is selected for tests when a K factor is used, since the actual flow rate through the molbloc is different from the device under test range in the process gas.

3.4.2 [GAS]

○ PURPOSE

To specify the gas that is currently flowing through the molbloc so that molbox RFM uses the correct gas property values in its flow calculations.

○ PRINCIPLE

molbox RFM calculates the flow through a molbloc from:

- molbloc geometric characteristics
- gas pressures
- gas temperature
- specific characteristics of the flowing gas

The gas characteristics include:

- gas density under standard conditions
- change in gas density with pressure and temperature
- gas viscosity under standard conditions (when needed)
- changes in gas viscosity with pressure and temperature

Proprietary algorithms are used to calculate gas density and viscosity (when needed) under the actual flowing pressure and temperature conditions from density and viscosity under standard conditions.

The characteristics of molbox RFM supported gases and corresponding algorithms are stored in molbox RFM memory. To correctly calculate the flow of a gas, the correct information for that gas must be used. The molbox RFM GAS function allows the user to specify the flowing gas so that molbox RFM will use the correct gas information in calculating the flow through the molbloc.

The set of available calibration gases that can be used is not the same with molbloc-L and molbloc-S, and the operation of the GAS function is different. They are described separately below.

3.4.2.1 molbloc-L Operation

The molbox RFM gases available for use with molbloc-L at the time of this manual printing are listed in Table 27.

Table 28. Available molbloc-L Gases

<1inert>	<2flammable>	<3toxic>	<4other>
<1N2> Nitrogen	<1H2> Hydrogen	<1CO> Carbon Monoxide	<1Air> Air
<2He> Helium	<2O2> Oxygen		<2C2F6> Hexafluoroethane
<3Ar> Argon	<3CH4> Methane		<3N2O> Nitrous Oxide
	<4C2H4> Ethylene		<4CF4> Carbon Tetrafluoride
	<5C3H8> Propane		<5SF6>Sulfur Hexafluoride
	<6C2H6> Ethane		<6CHF3> Fluoroform
	<7Butn> Butane		<7CO2>Carbon Dioxide
			<8Xe> Xenon
			<9C4F8> Octafluorocyclobutane

Note

- **<Butn>** is used to identify Butane in molbox RFM because the chemical symbol for Butane (C_4H_{10}) has more than the 4 characters used by molbox RFM to abbreviate gas identifications.
- **Mixtures of known gases in known concentrations can be measured by calculation and use of the ADJ function (see Section 3.5.6).**

○ OPERATION (molbloc-L OPERATION)

To specify the gas flowing through molbloc-L, press **[GAS]**. The display is:

```
1inert 2flammable
3toxic 4other
```

The gases available are grouped in categories to facilitate finding a specific gas and as a reminder to the user when selecting a gas that may require special precautions in use. There is a list of gases under each category. For example, the **<1inert>** selection displays:

```
1N2 2He 3Ar
```

A secondary menu displays when a specifically calibrated gas is selected. The menu includes: the name of the gas, calibration name, the calibrated flow range, the calibration type (PREM for premium or STD for standard) and the supported pressure range. If multiple calibrations are available for the selected gas arrow keys "<>" display after the pressure. Use the left right arrow keys to select the other calibrations.

```
He, HI 5.0 slm
STD 50-550 kPa <>
```

If the selected gas is not specifically calibrated on the molbloc a secondary menu displays indicating that the default calibration for the molbloc will be used to derive the flow of the selected gas. Press enter to proceed.

```
No Air cal, N2 coef
used [ENTER]
```

Select the desired gas. Pressing **[ENTER]** returns to the last run screen with the newly selected gas active. The selected gas is always displayed in the upper right hand corner of the MAIN run screen.

Note

The gas selected on molbox RFM should always be the gas that is flowing through the molbloc. molbloc/molbox does not use *K factors* or *gas conversion factors* between gases. When calibrating or testing a device with a *surrogate gas*, molbox RFM should be set to the *surrogate gas*. The *K factor* or *gas conversion factor*, if used, defines the relationship between the *surrogate gas* and the *process gas* for the device being tested, not for molbloc/molbox (see Section 3.4.1, PRINCIPLE). The *K factor* is supplied by the manufacturer of the device being tested.

3.4.2.2 molbloc-S Operation

The molbox RFM gases available for use with molbloc-S at the time of this manual printing are the same as molbloc-L, as listed in Table 27.

In addition to dry air, molbox RFM supports measurement of ambient (humid) air flow with molbloc-S. When Air is selected as the molbloc-S test gas, the user is prompted to enter a value of the humidity ratio (also known as the absolute humidity or water ratio) of the ambient air. The humidity ratio, W , is defined as the ratio of water mass to gas mass in the flowing air. It is different from the relative humidity value, which is usually expressed as a percentage. Typical values of W are between zero and 0.06. molbox RFM does not accept an entry for W greater than 0.1.

Typically, humidity measuring instruments report relative humidity, which is dependent on the ambient pressure and temperature. Users who do not have the W value available can use Fluke Calibration's free *Unit of Measure Converter* software utility or *COMPASS for molbox* calibration software to calculate W from measured pressure, temperature, and relative humidity. Visit www.flukecal.com, or see your Fluke Calibration sales representative for a copy of the *Unit of Measure Converter* software utility. Air relative humidity, pressure and temperature are converted to the humidity ratio, W , following Dalton's Rule and thermodynamic principals using water saturation properties:

$$W = .62188 \cdot \frac{P_g \cdot \left(\frac{RH}{100}\right)}{P_{amb} - P_g \cdot \left(\frac{RH}{100}\right)}$$

P_g is the water saturation pressure, which can be calculated as:

$$P_g = C_0 T_{amb}^3 + C_1 T_{amb}^2 + C_2 T_{amb} + C_3$$

where :

$$C_0 = 0.0649289$$

$$C_1 = -53.0528$$

$$C_2 = 14509.9$$

$$C_3 = -1327760$$

If dry air will be measured, then the user should enter a W value of zero when prompted. Zero is the default W value.

When a non-zero W value is entered, molbox applies a correction to its air flow measurement for the change in air density due to humidity. If a correction for W is

being applied to air flow measurements, a **<W>** is placed to the right of the **<Air>** gas indication in the MAIN run screen.

The humid air correction applied to the molbloc measured flow is (from ASME FEDSM98-5309):

$$q_m(\text{ratio}) = a + bW + cW^2 + dW^3$$

where:

$$a = 1.0000$$

$$b = -0.336872$$

$$c = 0.158514$$

$$d = 0.131924$$

Note

If an incorrect value of **W** is entered (for example, using any non-zero **W** value while flowing dry air), an error will be introduced into the air flow measurement. **W**, humidity ratio, is different from relative humidity.

○ OPERATION (molbloc-S operation)

To specify the gas flowing through molbloc-S, press **[GAS]**. The display is:

```
1inert 2flammable
3toxic 4other
```

The gases available are grouped in categories to facilitate finding a specific gas and as a reminder to the user when selecting a gas that may require special precautions in use. There is a list of gases under each category. For example, the **<4other>** selection displays:

```
1Air 2N2O 3SF6
4CO2
```

A secondary menu displays when a specifically calibrated gas is selected. The menu includes: the name of the gas, calibration name, the calibrated flow range, the calibration type (PREM for premium or STD for standard) and the supported pressure range. If multiple calibrations are available for the selected gas arrow keys "**<>**" display after the pressure. Use the left right arrow keys to select the other calibrations.

```
N2 , HI 5.0 slm
STD 50-550 kPa <>
```

If the selected gas is not specifically calibrated on the molbloc a secondary menu displays indicating that the default calibration for the molbloc will be used to derive the flow of the selected gas. Press enter to proceed.

```
No N2 cal, Air
coef used [ENTER]
```

Select the desired gas. If **<1Air>** is selected, the display is:

```
Humidity ratio:
0:1
```

Leave the value at zero when dry air is being flowed. Enter the appropriate non-zero value (see section immediately above) if humid air is being flowed.

Pressing **[ENTER]** returns to the last run screen with the selected gas active. The selected gas is always displayed in the upper right hand corner of the MAIN run screen.

Note

The gas selected on molbox RFM should always be the gas that is flowing through the molbloc. molbloc/molbox does not use *K factors* or *gas conversion factors* between gases. When calibrating or testing a device with a *surrogate gas*, molbox RFM should be set to the *surrogate gas*. The *K factor* or *gas conversion factor*, if used, defines the relationship between the *surrogate gas* and the *process gas* for the device being tested, not for molbloc/molbox (see Section 3.4.1 and 3.4.2 PRINCIPLE). The *K factor* is supplied by the manufacturer of the device being tested.

3.4.3 [UNIT]

○ PURPOSE

To specify the flow unit of measure in which molbox RFM displays measured flow values.

○ PRINCIPLE

molbox RFM calculates the mass flow of various gases in kilograms/second [kg/s]. molbox RFM also supports conversions to a variety of other flow units of measure. The UNIT function allows the user to select the flow unit of measure in which molbox RFM displays measured flow. These include units of mass flow, including volumetrically based mass flow units (i.e., sccm) as well as units of volume flow (i.e., ccm). See Table 29 for a complete listing of the unit conversions available. molbox RFM can also display the measured flow in two different units of measure simultaneously (see Section 3.4.6.5).

○ OPERATION

The UNIT function is used to set the unit of measure of the molbox RFM flow display. To change the flow unit of measure press [UNIT].

The display is:

1sccm 2slm 3uccm
4pccm 5mg/s 6vlm

Select the desired unit. For all units except <uxxx> or <vlm>, operation then returns to the run screen with the flow unit of measure changed to the selected unit. When user units (i.e., uxxx) are selected, the reference temperature must be specified before the unit is activated (see Section 3.4.3.3). When “vlm” (*volume*) units are selected, a menu of *volume* units is accessed. The desired volume unit must be selected and then the temperature and pressure of the flowing gas must be specified (see Section 3.4.3.4).

Note

- See Section 7.1.3 for specific molbox RFM flow unit conversion calculations.
- molbox RFM supports many more flow units of measure than the six default units of the UNIT function. The six units available under the UNIT function can be customized to include any molbox RFM supported units in any order (see Section 3.4.3.5).

⚠ Caution

Many different types of flow units are commonly used including a wide variety of mass flow units as well as volume flow units. Please read Sections 3.4.3.1 through 3.4.3.5 for additional information on the various unit definitions and how they are handled by molbox RFM before making unit of measure selections.

3.4.3.1 Mass Flow vs. Volume Flow

Note

COMPASS for molbox software users: conversions to volume (sometimes called actual) flow units are handled in COMPASS. When using COMPASS, the molbox always operates in mass flow units.

molbox RFM measures **mass flow** (quantity of material per quantity of time). molbox RFM always calculates flow in terms of kg/second [kg/s]. It also supports conversions of kg/second to a variety of other flow units. These include other mass flow units such as g/s and mole/s as well as volumetrically based mass flow units (i.e., sccm and slm) (see Section 3.4.3). **In steady state flow, mass flow is the same at different points in the flow system independent of gas pressure and temperature.** Therefore, the measurement of mass flow made by the molbloc/molbox represents the mass flow at the same time at other points in a steady state flow system.

molbox RFM can also make conversions to **volume flow** under specific pressure and temperature conditions by dividing the mass flow by the density of the gas under the specific pressure and temperature conditions (see Section 3.4.3.4).

Note

Volume flow is sometimes referred to as *actual* flow.

Volume flow is dependent on the actual temperature and pressure of the flowing gas at the point where volume flow is to be measured. Generally, this point is not at the molbloc, it is at another point in the flow system (e.g., at the device under test). At another point in the flow system, it is quite likely that the gas pressure and temperature are different from the gas pressure and temperature at the molbloc. Then, even in steady state flow conditions, the volume flow at the molbloc and the volume flow at another point in the system are likely to be different. Therefore, ***to accurately predict volume flow at another point in the system, molbox RFM must calculate volume flow based on the mass flow through the molbloc and the gas pressure and temperature at that other point, not at the molbloc.*** For this reason, molbox RFM requires that gas pressure and temperature conditions at the DUT be specified for volume flow measurements.

Estimating the flowing gas pressure and temperature at the point at which volume flow is to be measured may be difficult.

The relevant gas pressure when measuring volume flow is the gas's absolute pressure. In cases in which the volume flow measurement is open to atmospheric (ambient) pressure, the volume flow pressure is atmospheric pressure. In other cases, there may be ways to estimate the pressure at the volume flow measurement point but it probably should be measured.

For temperature, if the volume flow measurement point is very near the molbloc, one possibility is to use the molbloc temperature measurement. By design, the molbloc causes the temperature of the gas that flows through the molbloc to take on the molbloc temperature. Therefore, the temperature of the gas as it exits the molbloc is the same as the molbloc temperature. If the volume flow measurement point is not immediately downstream of the molbloc, the best estimate of gas temperature may be ambient temperature or the temperature of the device or bath used to stabilize gas temperature if one is present.

⚠ Caution

Because volume flow (sometimes called *actual* flow) is dependent on gas pressure and temperature at the flow measurement point, gas pressure and temperature must be specified by the user when selecting volume flow units on molbox RFM. The measurement uncertainty (accuracy) in the volume flow measurement is highly dependent on the measurement uncertainty in the pressure and temperature specified. Typically, temperature errors have an effect on flow of about 0.35 %/°C and pressure errors have an effect on flow of about 1%/kPa (6.8%/psi) if the DUT is used near atmospheric pressure.

3.4.3.2 Volumetrically Based Mass Flow Units

molbox RFM supports a number of volumetrically based mass flow units of measure. Volumetrically based **mass flow units** should not be confused with **volume or actual flow units** (see Section 3.4.3.4). Volumetrically based mass flow units define mass in terms of the quantity of gas that occupies a volume under *standard* conditions of pressure and temperature. Since there is no universally accepted definition of standard conditions, molbox RFM supports the three most common variances.

- **Standard units (sxxx):** The “s” prefix indicates *standard*. Volumetrically based mass flow units preceded with the letter “s” (i.e., sccm, slm, scfh) define standard conditions as pressure of 101.325 kPa absolute (14.6959 psia) and temperature of 0 °C (32 °F) and take into account the true compressibility of the flowed gas.
- **User units (uxxx):** The u prefix indicates *user*. This option is designed to provide support for volumetrically based mass flow units with a reference temperature other than 0 °C (see Section 3.4.3.3). Volumetrically based mass flow units preceded with the letter “u” (i.e., uccm, ulm) define standard conditions as pressure of 101.325 kPa (14.6959 psia) with the user specifying the reference temperature. User units take into account the true compressibility of the flowed gas.
- **Perfect units (pxxx):** The “p” prefix indicates *perfect*. This option is designed to provide support for volumetrically based mass flow units that assume ideal gas compressibility for all gases. Volumetrically based mass flow units preceded with the letter “p” (i.e., pccm, plm) assume a gas compressibility factor of 1 for all gases and define standard conditions as pressure of 101.325 kPa (14.6959 psia) and temperature of 0 °C (32 °F).

Note

- **Volumetrically based mass flow units at reference temperatures other than 0 °C (32 °F) can be defined using user units (see Section 3.4.3.3).**
- **In early 1996, SEMI (a semiconductor industry interest group) adopted standard E12-96, which specifies that perfect units be used for volumetrically based mass flow units. To comply with the SEMI standard, pccm should be used rather than sccm. To purchase a copy of the relevant SEMI standard, contact SEMI by visiting the Contacts page at www.semi.org or email semihq@semi.org.**

3.4.3.3 Volumetrically Based Mass Flow Units at Various Reference Temperatures (UXXX)

Units starting with the letter “u” (*user* units) are volumetrically based mass flow units (see Section 3.4.3.3) for which a reference temperature other than 0 °C is desired.

When a *user* unit is selected, the reference temperature desired must be specified. After a user unit is selected, the display is:

```
Temperature ref?
      0°C
```

Enter the reference temperature desired for the volumetrically based mass flow unit selected. The temperature unit can be changed between °C and °F by pressing [SETUP] and selecting <3tempU> (see Section 3.5.3). The temperature selected applies to all the user units.

Note

Volumetrically based mass flow units, including *user* units (uxxx) and *perfect* units (pxxx), are discussed further in Section 3.4.3.2.

3.4.3.4 Volume Flow Units (vlm)

Note

See Section 3.4.3.1 before using volume flow units. Volume flow is sometimes referred to as *actual* flow.

To measure flow in volume flow units (sometimes referred to as *actual* flow units), press [UNIT], <vlm> under the UNIT function. If <vlm> is not available, see Section 3.4.3.5. This selection accesses the menu of volume units available. Select the desired volume flow unit:

1. Current volume flow pressure.
2. Current volume flow temperature. Indicates <bloc> if the current setting is to use the molbloc temperature.

```

      1           2
      ↓           ↓
P101.325kPa T21.1°C
Edit P&T? 1no 2yes
```

To retain the current volume flow pressure and temperature, select <1no> and operation returns to the MAIN run screen with the selected volume flow unit active. To change the volume flow pressure and/or temperature select <2yes>.

The next screen gives the choice of having the volume flow gas temperature be either the molbloc temperature or a user specified temperature. If <2user> is selected, a screen to enter the temperature is presented before continuing. If <1molbloc> is selected, the volume flow temperature will automatically be taken as the molbloc temperature.

```
Gas temperature:
  1molbloc  2user
```

The next screen is to edit the volume flow pressure in the current pressure unit of measure. Pressing [ENTER] accepts the edited value as the volume flow pressure and returns to the MAIN run screen with the selected volume flow unit and gas temperature and pressure active.

```
Volume unit gas pres
101.325 kPa
```

Note

The temperature and pressure units of measure used to specify volume flow conditions can be changed using [SETUP], <2presU> for pressure (see Section 3.5.2) and [SETUP], <3tempU> for temperature (see Section 3.5.3).

⚠ Caution

Because volume flow is dependent on gas pressure and temperature at the flow measurement point, gas pressure and temperature must be specified by the user when selecting volume flow units. The measurement uncertainty in the volume flow measurement is highly dependent on the measurement uncertainty in the pressure and temperature specified (see Section 3.4.3.1).

3.4.3.5 Customizing FLOW Units Available Under The UNIT Function

The UNIT function provides a choice of six different flow units of measure. The units that are available by default are the six indicated in Section 3.4.3. However, molbox RFM supports many other units. These other units can be made available for selection by customizing the UNIT function.

To customize the UNIT function, press [SETUP] and select <1flowU>. The display is:

```
Set up user unit #1
```

<#1> corresponds to the first of the six available selections under the UNIT function. Enter the number of the selection that you would like to change. The display becomes:

```
Flow unit type: 1std
                2user 3perfect 4vlm
```

Select the flow unit type of the desired flow unit (see Table 29). Then select the desired unit.

Table 29. Available Flow Units

<1std>	<2user>	<3perfect>	<4vlm>
<1mol/s>	<1ulm>	<1plm>	<1ccm>
<2kg/s>	<2uccm>	<2pccm>	<2lm>
<3mg/s>	<3ucfm>	<3pcfm>	<3lh>
<4slm>	<4ucfh>	<4pcfh>	<4m3h>
<5sccm>	<5um3h>	<5plh>	<6cfm>
<6scfm>		<6pm3h>	<7cfh>
<7scfh>			
<8slh>			
<9sm3h>			

Note

The <4vlm> unit selection embeds the selection “vlm” into the UNIT function rather than a specific volume unit. The “vlm”

selection provides access to all of the volume flow units. In summary the unit types are:

<1std> (standard): mass flow units for which “standard” conditions are temperature of 0 °C, standard atmosphere and using the true compressibility factor of the gas.

<2user>: mass flow units for which “standard” conditions are a user settable temperature, standard atmosphere and using the true compressibility factor of the gas.

<3perfect>: mass flow units for which “standard” conditions are temperature of 0 °C, standard atmosphere and assuming a compressibility factor of 1 for all gases.

<4vlm>: volume flow units.

See Sections 3.4.3.1 to 3.4.3.4 for additional information on flow unit types.

3.4.4 [TARE]

○ PURPOSE

[TARE] accesses five functions.

- **TARE function:** To zero the molbox RFM differential pressure readings during molbloc-L operation or verify the two RPTs by comparing them against each other during molbloc-S operation (see Section 3.4.4.1).
- **PURGE function:** To purge the molbloc connecting lines and molbox RFM internal volume of a first gas with a second gas by flowing the second gas through the molbox RFM (see Section 3.4.4.2).
- **LEAK CHECK function:** To check the molbox RFM internal pneumatic circuit and/or the external test circuit to which molbox RFM is connected, for leaks (see Section 3.4.4.3).
- **AUTOZ function:** To periodically offset the molbox RFM RPTs relative to a reference pressure value in order to compensate for possible changes in the RPT zero between full recalibrations (see Section 3.4.4.4).
- **BPR function (present only in molbloc-S operation):** To measure and display the molbloc-S back pressure ratio (BPR) while operating in a BPR mode, which does not continuously read and display BPR (see Section 3.4.4.5).

○ OPERATION

Pressing [TARE] accesses a display with the choice of four functions (five functions with molbloc-S). Select the desired function. See the following for principles and operation:

1tare	2purge	
3leak check	4AutoZ	↓
5BPR		

Note

Some screens (e.g., the Tare menu) may go beyond the two lines provided by the display. This is indicated by a flashing arrow in the second line of the display. Press the [←] and [→] keys to move the cursor to access the lines that are NOT visible or directly enter the number of the hidden menu choice if you know it.

3.4.4.1 <1Tare>

The purpose and operation of the tare function is different for molbloc-L and molbloc-S operation. Tare values are generated and stored independently for the two molbloc types. For example, a tare value generated during molbloc-L operation is not used during molbloc-S operation, but is saved and used again when a molbloc-L is connected to the molbox.

Tare is described separately for the two molbloc types below.

3.4.4.1.1 molbloc-L OPERATION

○ PURPOSE

To zero the molbox RFM differential pressure reading at the molbloc operating pressure. Zeros the differential between the two high pressure absolute transducers as well as the microrange transducer if present.

○ PRINCIPLE

The molbox RFM TARE function can be considered the equivalent of the ZEROING function performed on many instruments prior to making measurements. molbox RFM calculates the flow through the molbloc from the differential pressure across the molbloc. The differential pressure across the molbloc is measured by taking the difference in the absolute pressure measured by the molbox RFM's two internal RPTs. One RPT is connected to the upstream molbloc pressure port and the other to the downstream molbloc pressure port. If the molbox RFM has the microrange option (see Section 3.1.5), when the differential pressure is under 12.5 kPa (1.8 psi), the microrange option's low differential RPT is used as the source of the differential pressure measurement.

If a common pressure is applied to both absolute transducers (and both legs of the microrange option differential RPT if present) the differential pressure indicated should be zero. If a differential pressure is observed, the value indicated represents an offset in the differential measurement, which will appear as an offset or "zero error" on the flow through the molbloc calculated by the molbox RFM. The TARE function allows the differential indication between the two RPTs to be zeroed at the molbloc operating pressure to eliminate the zero error in differential pressure measurement.

When the TARE function is activated, molbox RFM's internal valves operate to pneumatically connect together the two absolute transducers, and both legs of the microrange option differential transducer if present, at the molbloc operating pressure. The user can select whether this pressure is the upstream or downstream molbloc pressure so that the *tare* can be made at the pressure that will be held stable during operation (generally by a regulator or because it is open to atmosphere). Activating the *tare* causes molbox RFM to record the current differential as the *tare value*. The *tare value* will be used to correct all subsequent RPT readings. For the absolute transducers the *tare value* is the difference between the two transducer readings ($hi - lo$). The upstream RPT will be corrected by $(- \text{tare value}/2)$ and the downstream RPT will be corrected by $(+ \text{tare value}/2)$. For the microrange differential RPT, the *tare value* is the differential value read. The differential transducer will be corrected by subtracting the *tare value* from the current reading.

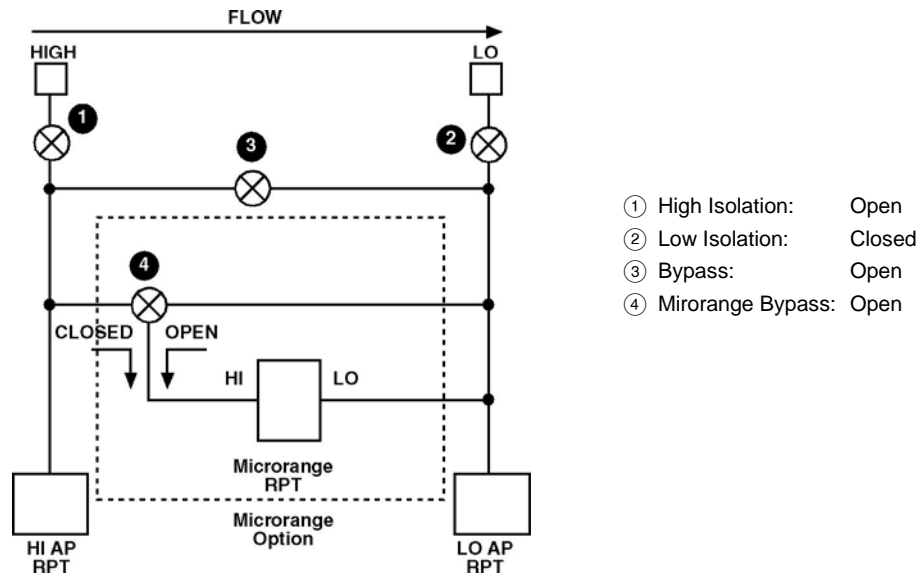

Figure 6. molbox RFM
Internal Pneumatic Schematic – TARING, UPSTREAM molbloc-L OPERATION

○ OPERATION

Note

At a minimum, the TARE function should be executed whenever the operating pressure of the molbloc is changed significantly, at the beginning of each test or any time a significant zero error is observed. For best results, it is possible to *tare* before every reading since taring can be executed while flowing. Best results will be obtained if the TARE function is executed with a stable flow through the molbloc.

To access the TARE function press [TARE], <1tare>.

The display is:

```
Select tare pressure:
1upstream 2dnstream
```

Selecting <1upstream> will *tare* the molbox RFM RPTs at the molbloc's upstream pressure (see Figure 5). Selecting <2dnstream> will *tare* the RPTs at the molbloc's downstream pressure (Low isolation valve open, High isolation valve closed). Select the position where the pressure will remain the most stable during molbloc operation.

The next display is:

1. The current pressure read by the upstream (left) and downstream (right) RPTs without taking into account the current *tare value*. These are *untared* readings in the current pressure units.
2. <T>, flashing, to indicate that this is a TARE display showing the *tare* between the two absolute RPTs.
3. The difference between the *untared* upstream and downstream absolute pressure readings (upstream – downstream). This differential value is always in Pascal [Pa].
4. The flow corresponding to the current *untared* differential pressure in the current flow units.

```

      1
      ↓
202.347 kPaa 202.311
T  36 Pa  0.06 sccm
↑    ↑    ↑
  2   3   4

```

This display allows the current *untared* absolute pressures and the resulting *untared* differential pressure from the difference of the two absolute RPTs to be observed. The flow value represents the current *untared* zero error in terms of flow. It does not necessarily represent the current zero error on flow measurements as a *tare value* other than zero is probably already active.

Press [ENTER] when ready. molbox RFM makes measurements to determine a new tare value. The next display is:

1. The *tare value* currently in use [Pa].
2. The new tare value, resulting from this execution of the TARE function [Pa].
3. Microrange *tare value* currently in use [Pa]
4. New microrange *tare value* [Pa].

	1		2
	↓		↓
OldT:	44Pa	m	20
NewT:	36Pa	m	20
	↑		↑
	3		4

Press [ENTER] to activate the new *tare* and return to the MAIN run screen.

Press [ESCAPE] to return to the [TARE] display without activating the new *tare*, leaving the old *tare* active.

Note

The tare screen shows the upstream and downstream RPT readings WITHOUT the current tare applied. The [P&T] screen shows the RPT readings WITH the tare applied (see Section 3.4.5).

Limits and Errors

Excessively large *tare* values can diagnose molbox RFM transducer malfunction, the need to recalibrate or possible poor execution of the TARE function. To protect against improper *taring* and to alert to possible RPT malfunction, molbox RFM checks the *tare values* before they are activated and displays warnings when appropriate. In the most extreme case, molbox RFM will not allow the *tare value* to be activated. The limits checked and their consequences are as follows:

Upstream and downstream absolute pressure RPTs coherence test: When attempting to activate a new *tare*, molbox RFM checks the coherence between the two transducers and alerts the operator to excessive disagreements. The test has two levels.

If the new *tare* is 700 Pa < *tare* > 10 000 Pa, a caution message is displayed. Pressing [ENTER] overrides the caution and activates the new *tare*. Pressing [ESCAPE] returns to the TARE screen.

If the new *tare* is > 10 000 Pa, the new *tare* cannot be activated. Pressing [ENTER] or [ESCAPE] returns to the *tare* screen. It is likely that molbox RFM needs service or a grossly incorrect adjustment has been made to one or both of the RPTs.

Microrange differential pressure RPT zero drift test (if microrange option present): When attempting to activate a new *tare*, molbox RFM checks the zero offset value of the microrange RPT. If the new *tare* is > 999 Pa, the new *tare* cannot be activated. Press [ENTER] or [ESCAPE] to go back to the *tare* screen. It is likely that molbox RFM needs service or a grossly incorrect adjustment has been made to the differential RPT.

Note

If a caution message appears or a tare cannot be activated during the taring process, repeat the taring process. If the caution persists, the calibration of the RPT(s) should be verified. If the tare still cannot be activated, the RPT(s) should be recalibrated and molbox RFM may require other service.

3.4.4.1.2 molbloc-S Operation

○ PURPOSE

To check the molbox RFM RPT absolute pressure readings by comparing them at a common molbloc-S upstream absolute pressure.

○ PRINCIPAL

When measuring the flow through molbloc-S, the critical pressure measured by molbox RFM is the molbloc upstream pressure. The downstream pressure is only monitored to be sure that critical flow conditions exist (see Section 3.1.2). To reduce the uncertainty on the upstream pressure measurement, molbox RFM employs internal valving to direct the upstream pressure to both RPTs, and the average of the two readings is used as the measured molbloc upstream pressure. To take advantage of this RPT averaging, the molbox RFM must be in either BPR OFF or Auto BPR mode (see Section 3.6.9).

molbox RFM dynamically tares the two RPT readings when they are connected together, so the user can view the “live” average pressure that is calculated and to allow smooth pressure and flow measurements during valve transitions in the Auto BPR mode (see Section 3.6.9). RPT taring in molbloc-S operation occurs automatically when needed and does not need to be initiated or performed by the user.

The molbloc-S TARE function is available to allow the user to conveniently verify that the two RPT measurements agree within an acceptable tolerance when a common pressure is applied to them. When the TARE function is selected, the molbox RFM internal valves operate to connect both Q-RPTs the active channel UPSTREAM pressure port (see Figure 6). The RPT readings and the difference between the two RPT readings (*tare* value) is displayed for evaluation by the user. A message is also displayed to indicate to the user whether the tare value is acceptable, or indicates a need for pressure verification or calibration of the RPTs. There is no need for the customer to save a new tare value during molbloc-S operation.

As during molbloc-L operation, the molbloc-S *tare* value is the difference between the two transducer readings ($hi - lo$). In BPR modes where the tare value is dynamically calculated and applied, the upstream RPT is corrected by $(- \textit{tare value}/2)$ and the downstream RPT is corrected by $(+ \textit{tare value}/2)$.

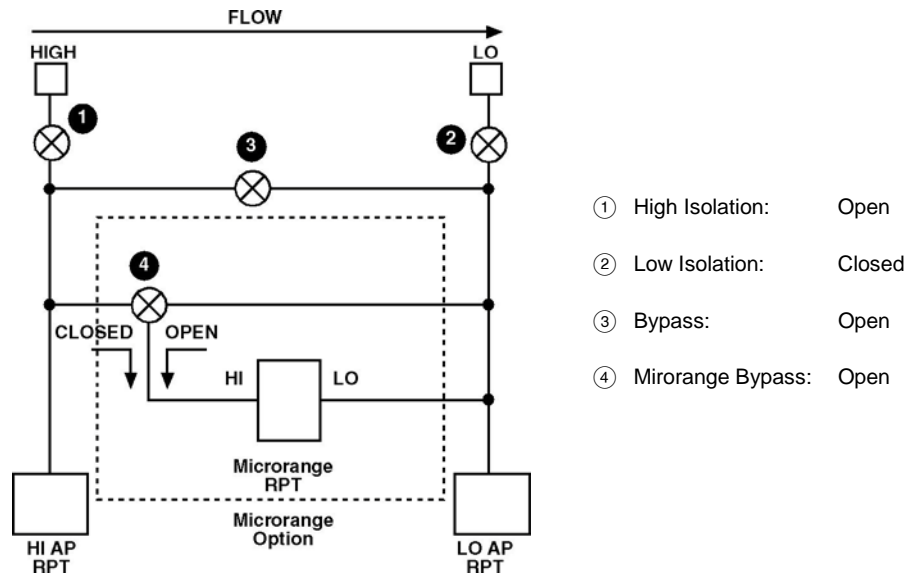
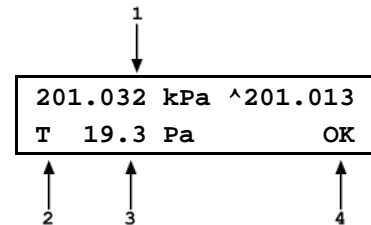

Figure 7. molbox RFM
Internal Pneumatic Schematic – TARING molbloc-S OPERATION

○ OPERATION

To access the TARE function press **[TARE]**, **<1tare>**. The display is:

1. The current pressure read by the upstream (left) and downstream (right) RPTs without taking into account the current tare value. These are *untared* readings in the current pressure units.
2. **<T>**, to indicate that this is a TARE display showing the tare between the two absolute RPTs.
3. The difference between the *untared* upstream and downstream absolute pressure readings (upstream – downstream). This differential value is always in Pascal [Pa].
4. Tare message
<OK> If tare is less than 300 Pa,
<CHECK> if tare is between 300 and 1250 Pa
<NEED CAL> if tare is greater than 1250 kPa



Note

The tare screen shows the upstream and downstream RPT readings **WITHOUT** the current tare applied. The [P&T] screen shows the RPT readings **WITH** the tare applied (see Section 3.4.5).

3.4.4.2 <2Purge>

○ PURPOSE

To purge the lines between the molbloc and the molbox RFM and the internal molbox RFM volumes of one gas with another gas by setting up an internal valving configuration in which gas flows through the molbox RFM.

○ PRINCIPAL

molbox RFM supports the measurement of flow of a variety of gases. To calculate the flow, the thermodynamic characteristics of the gas must be known. These are stored in molbox RFM memory. For the flow to be calculated correctly,

the gas flowing through the molbloc must be the gas that is selected on the molbox RFM (see Section 3.4.2). When switching from the measurement of one gas to another, the old gas remaining in the circuit and the new gas being flowed may mix for some time so that the gas flowing through the molbloc is not purely the new gas. Erroneous measurements may result. For this reason, it is important to purge the lines upstream and downstream of the molbloc when changing gases. It is also important to purge the molbox RFM itself which, since there is normally no flow through it, may trap and hold the old gas.

The PURGE function is designed to facilitate purging the molbox RFM. It sets up the molbox internal valving so that flow can pass through the molbox RFM (see Figure 7). In this configuration, the lines between the molbloc and molbox RFM and the molbox RFM internal volume can be purged by simply flowing the new gas in the normal flowing configuration. The flow resistance through the molbloc creates a differential pressure, which causes flow through the molbox RFM to occur, purging it with the new gas.

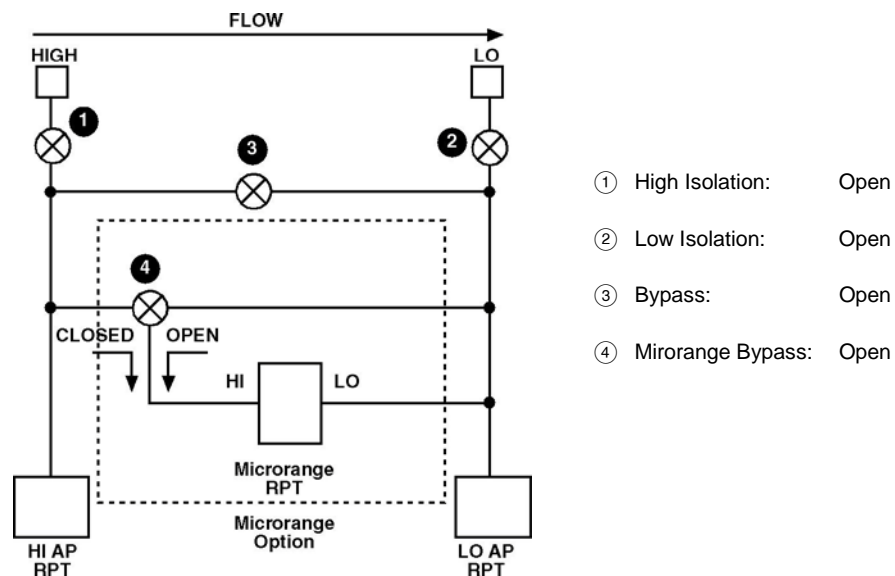

Figure 8. molbox RFM
Internal Pneumatic Schematic – PURGING

○ OPERATION

Note

For best results, the PURGE function should be executed whenever the species of the gas flowing through the molbloc is changed. Prior to activating the PURGE function, set flow through the molbloc to the highest rate that is practical. Then, with the gas flowing, activate the PURGE function. Very small volumes of gas remain trapped (dead ended) in the molbox RFM in the PURGE configuration. Therefore, it may be desirable to execute the PURGE function more than once to clear these volumes by the pressure changes caused by PURGE execution.

To access the PURGE function press [TARE], <2purge>. The display is:

Set purge time: 15 sec

The purge time can be edited. Pressing [ENTER] causes molbox RFM to set its internal valving to the purge configuration (see Figure 14) and go to the PURGE display:

1. The current pressure read by the upstream (left) and downstream (right) RPTs in the current pressure unit of measure.
2. <PURGING> to indicate that this is a PURGE display.
3. Countdown of purge time remaining in seconds.

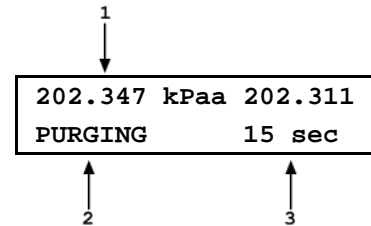

molbox RFM remains in the purge condition until the purge time countdown elapses. It then automatically returns to normal operation. When the countdown elapses operation returns to the run screen from which PURGE was accessed.

To interrupt the PURGE function, press [ESCAPE].

Note

The appropriate purge time setting is dependent on the flow rate and the volumes upstream and downstream of the molbloc. Typically, 15 to 30 seconds is adequate. The time needed increases as flow rates go down and volumes go up.

⚠ Caution

When using the PURGE function, remember that the molbox RFM absolute RPTs are exposed to the pressure. Do not apply pressure greater than 600 kPa absolute (87 psia).

3.4.4.3 <3Leak Check>

○ PURPOSE

To access the molbox LEAK CHECK and SYSTEM LEAK CHECK functions which use molbox RFM's pressure and flow measurement capabilities to check molbox RFM and/or the system to which it is connected for leaks.

○ PRINCIPAL

molbox RFM is used both as a tool to accurately measure unknown flow values and as a calibration standard to calibrate other devices by comparison. Leaks within the molbox RFM pneumatic circuit can cause erroneous flow measurements. Leaks in the external flow circuit can cause the flow through the molbloc to be different from the flow at another point in the system so that, even with an accurate measurement and steady state flow, the molbox RFM indication is not an accurate indication of flow at the other point in the system.

To obtain valid measurement results, it is important that leaks in molbox RFM and/or the external flow system be identified and eliminated to the extent possible. molbox RFM uses its precision on-board pressure and flow measurement capabilities to help identify leaks with INTERNAL and EXTERNAL LEAK TESTING functions.

○ OPERATION

Press [TARE] and select <3leak check> to access the LEAK CHECK functions. Then select <1molbox> or <2system>.

<1molbox> is designed to leak check the internal molbox RFM pneumatic circuit.

<2system> is designed to leak check the system to which the molbloc/molbox is connected.

3.4.4.3.1 Leak Check molbox

○ PURPOSE

To check the internal molbox RFM pneumatic circuit for leaks.

○ PRINCIPAL

It is normally not necessary to run the MOLBOX LEAK CHECK procedure frequently. It is intended for troubleshooting purposes when there appears to be a leak or other molbox RFM measurement problem whose source cannot be identified by the SYSTEM LEAK CHECK or other troubleshooting means. It is recommended to run the MOLBOX LEAK CHECK after it has been shipped or if it is suspected that the molbox has been exposed to a large shock or liquid or particulate contamination.

○ OPERATION

Press **[TARE]** and select **<3leak check>**, **<1molbox>**. If the molbox RFM has a microrange option, microrange RPT **<1active>** or **<2bypassed>** must be selected to proceed (see Section 3.1.5). The next display is:

1. The pressure read by the upstream transducer (left), the downstream transducer (right) and the pressure unit of measure (middle).
2. Indicator that the figure that follows is differential pressure.
3. Differential pressure across the molbloc in current pressure unit of measure.
4. Prompt for the action to take when ready.

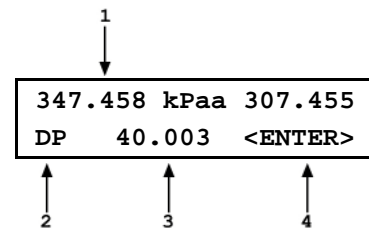

The molbox RFM internal valving is in its normal measuring configuration (see Figure 3). This display is intended to assist the operator in setting the leak check pressure.

Apply the maximum differential pressure across the molbloc that is normally encountered during flow measurement while working at your typical absolute working pressure. Neither pressure should be less than atmosphere. Use the **<DP>** indication on the molbox RFM display to set the absolute and differential pressure.

Once the pressure setting is correct, press **[ENTER]**. The molbox RFM actuates its internal valves to isolate itself from the molbloc and trap the upstream and downstream pressures on its RPTs (see Figure 8). The display is:

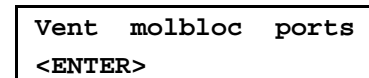

Assure that both molbox RFM rear panel pressure connections are vented. Since the pressure quick connections on the molbox RFM and the quick-connectors on the molbloc pressure connection tubes seal when disconnected, they cannot be vented by simply disconnecting them. The easiest way to assure that the connections are vented is to maintain the normal connections to the molbloc, shut off the molbloc gas source and open one or both ends of the molbloc so it can vent to atmospheric pressure. Another alternative is to install the non-sealing quick connectors (Fluke P/N 3068652) provided in the molbox accessories (see Section 2.1.2) into the molbox quick connectors.

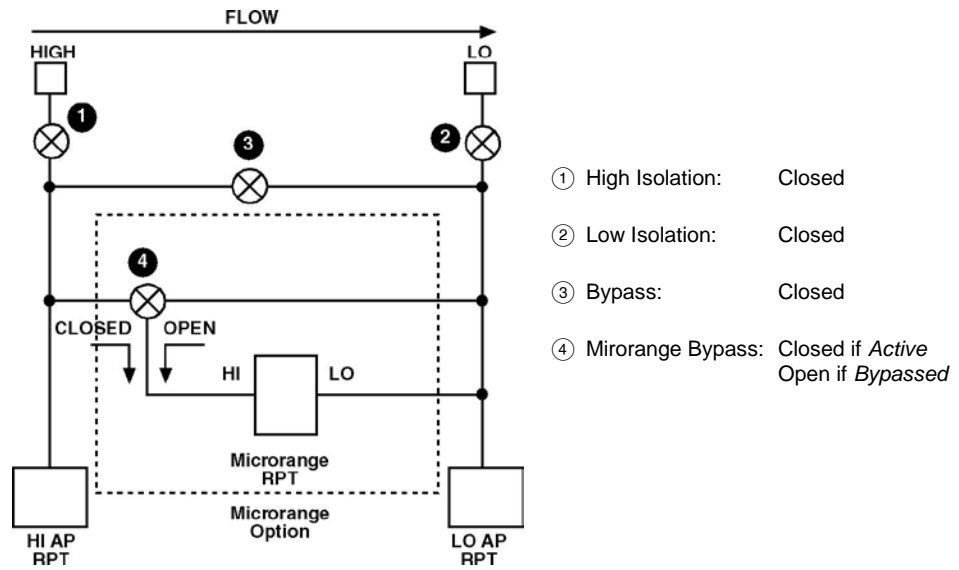
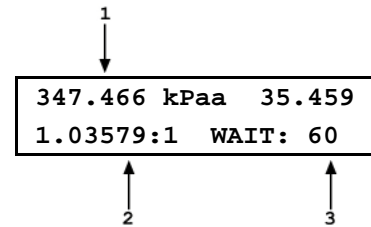

Figure 9. molbox RFM
 Internal Pneumatic Schematic – LEAK CHECK molbox

Once the molbox RFM pressure connections are vented, press **[ENTER]**.

1. The pressure read by the upstream RPT (left), the downstream RPT (right) and the pressure unit of measure (middle).
2. The ratio of the upstream RPT reading to the downstream RPT reading.
3. Leak check count down in seconds.



molbox RFM counts down for 60 seconds while monitoring the ratio of the two pressures and then determines whether an internal leak was present. A significant leak in a pressure isolation valve or a bypass valve between the two channels will cause the ratio between the two pressures to vary.

The molbox RFM LEAK CHECK function should end with the prompt:

```
molbox passed the
leak check
```

If any other prompt is present, repeat the process. If the molbox RFM is equipped with the microrange option, run the leak test with the microrange in the opposite condition (active or bypassed). If the leak check fails consistently, note the failure message and contact a Fluke Calibration Authorized Service Provider.

3.4.4.3.2 Leak Check System

○ PURPOSE

To leak check the external system that is connected to the molbox RFM.

○ PRINCIPAL

It is recommended to run the SYSTEM LEAK CHECK whenever critical physical connections in the system attached to the molbloc are broken and reconnected. Critical connections are ones that are between the molbloc and the DUT, which, if they were to leak, would cause the flow through the molbloc and the DUT to differ. Whenever a new DUT is connected to the system, it is a good idea to run the SYSTEM LEAK CHECK.

The SYSTEM LEAK CHECK monitors changes in pressure in a closed system defined by the user to help determine whether a leak exists in the system. One of the ways a leak is detected is by monitoring pressure decay in the pressurized closed system. When the test volume is large, significant leaks may exist without being detected because the pressure decay caused by the leak is reduced. Therefore, the SYSTEM LEAK CHECK is most effective when the volume of the closed system is minimized.

For molbloc-L operation, the SYSTEM LEAK CHECK also measures flow through the molbloc to help determine whether a leak is present upstream or downstream of the molbloc. Since molbloc-S is not capable of calculating meaningful flow values with the very small differential pressure present during this test, the SYSTEM LEAK CHECK operates differently for molbloc-L and molbloc-S operation, as described in the OPERATION sections immediately below.

Note

The SYSTEM LEAK CHECK function uses molbox RFM's high precision pressure and flow measurement capabilities to help determine whether a leak exists in the system to which the molbloc is connected. This feature is to assist the operator in flow measurement and calibration. The system to which the molbloc is connected is the responsibility of the user. Failures in the system leak check do not normally indicate defects in the molbox RFM or molbloc itself. The molbox leak check is used to identify molbox RFM failures.

○ OPERATION – molbloc-L Operation

To access the system leak check press [TARE] and select <3leak check>, <2system>. The display is:

1. The pressure read by the upstream RPT (left), the downstream RPT (right) and the pressure unit of measure (middle).

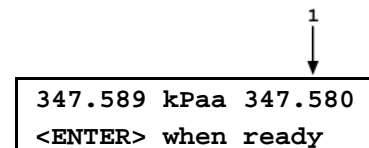

347.589 kPaa 347.580
<ENTER> when ready

This display is intended to assist the operator in setting the leak check pressure. molbox RFM has actuated internal valves to connect the upstream and downstream RPTs together, so they are both measuring an equal system pressure. (see Figure 9).

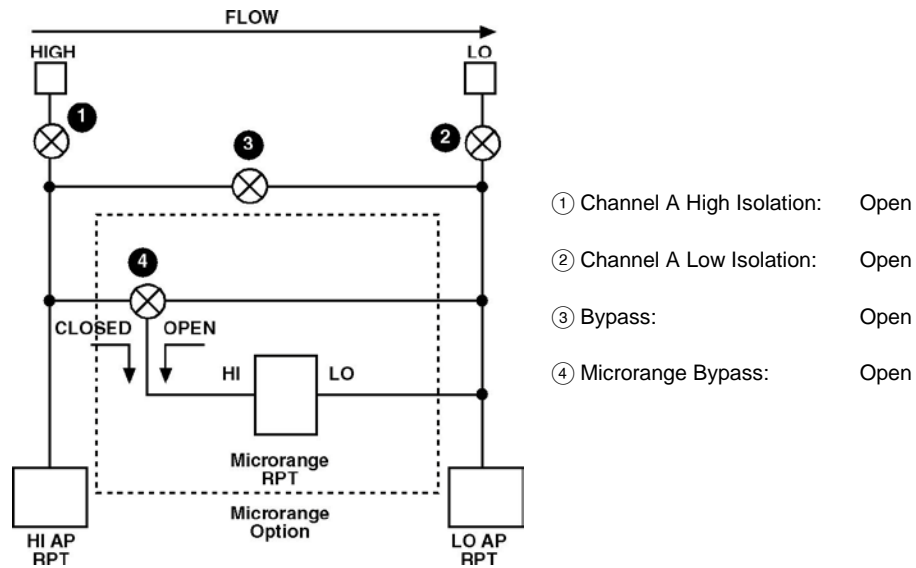

Figure 10. molbox RFM
Internal Pneumatic Schematic
– SYSTEM LEAK CHECK – CHECKING OFFSET AND STABILITY
molbloc-L operation

Close an isolation valve downstream or plug the exhaust of the flow system that is being tested (downstream of the molbloc and the DUT if the molbloc/molbox is being used to test another device).

Using the molbox RFM display to read the pressure set the pressure to the normal operating pressure.

Note

For systems with mass flow controllers (MFCs):

Keep in mind that the valves in most MFCs are not intended to provide a complete gas shutoff and so they may not be suitable to close off the test system. If an MFC is downstream of the molbloc and its downstream port is open to atmosphere, it is best to close the system by connecting a cap to the MFC outlet fitting or by connecting a shutoff valve downstream. If the MFC valve is closed (most MFCs have normally closed valves) when the operating pressure is applied from the upstream side, most of the gas will be stopped by the MFC valve and will not immediately fill the volume between the MFC valve and the downstream cap or valve. If this happens, the gas may leak by the MFC valve to fill this volume during the test and cause a pressure decay and an apparent system leak. The solution is to send a setpoint signal to the MFC to open the MFC valve while pressurizing the system. Then close the MFC valve (remove the setpoint signal) after the system is pressurized to avoid heating of the test gas by the energized valve.

Next, close an isolation valve upstream of the molbloc so the gas supply is no longer open to the system being checked. Once the pressure has stabilized, press [ENTER]. The display is:

347.587 kPaa	347.583
WAIT: 30	

The molbox RFM is checking:

- For pressure and temperature stability before running the system leak test
- That the disagreement between the two RPTs is not excessive

After 30 seconds, if the stability check is not passed, molbox RFM displays:

- If the pressure was not stable:

Leak is too large to continue

- If the molbloc temperature change was too great:

Temp change was too great to find leaks

- If the offset between the RPTs was too great:

Offset excessive check tare

If any of the above three prompts occurs, check the external system for leaks and/or run the molbox RFM leak check before proceeding. If the *tare* was excessive, *tare* the molbox RPTs before running the leak check again (see Section 3.4.4.1).

Once the 30 second pressure stability/offset check has been successfully completed, molbox RFM displays:

347.592 kPaa 347.583
0.101 sccm [ENT]

When [ENTER] is pressed, molbox RFM's valves actuate to set up the system leak check configuration which is identical to the normal operating configuration (see Figure 3). The display becomes:

1. Pressure read by the upstream RPT (left), the downstream RPT (right) and the pressure unit of measure (middle).
2. Current measured flow.
3. Time remaining in the leak check in seconds.

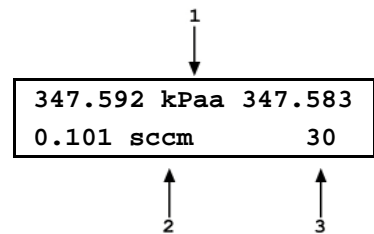

molbox RFM measures pressure and flow for a 40 second countdown. After the countdown has elapsed, molbox RFM displays its conclusion from the measurements. The display will be either:

possible system upstream leak or possible system downstream leak or System passed system leak check

Upstream and downstream refer to the possible location of the leak relative to the position of the molbloc and the normal flow direction in the system. If you are unable to locate a leak in the flow path components, check or replace the upstream and downstream molbloc to molbox pressure tubes and their connectors and retry the test. They are a critical part of the pneumatic system and if a significant leak is present in these tubes, it will cause an error in flow measurement.

○ OPERATION – molbloc-S Operation

In molbloc-S operation, SYSTEM LEAK CHECK is a one-part test which tests for pressure decay in the closed system.

To access the system leak check press [TARE] and select <3leak check>, <2system>.

The display is:

Leak check:
1run 2view

If <2view> is selected the test results screen (see below) is displayed with the results from the most recent leak test.

To run the leak test, select <1run>.

molbox RFM actuates internal valves to connect the upstream and downstream RPTs together, so they are both measuring an equal system pressure. (see Figure 10).

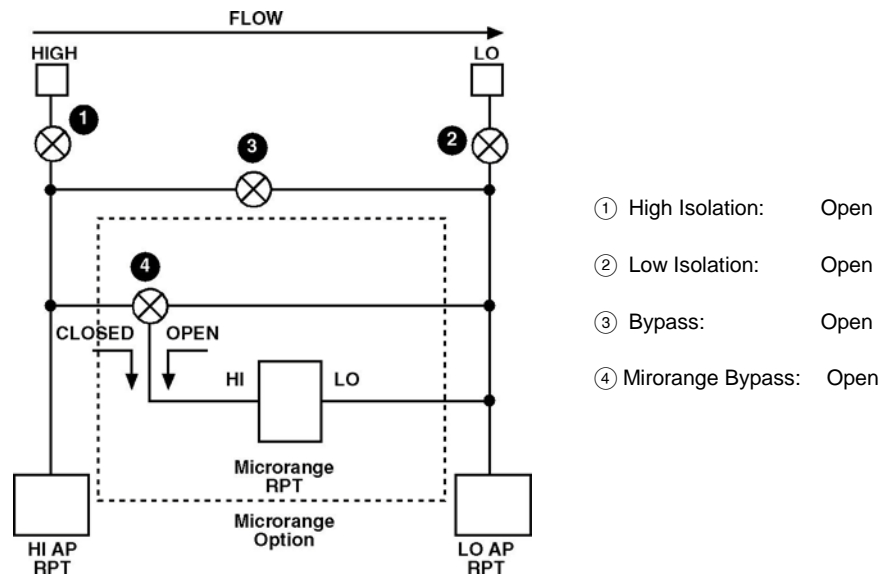

Figure 11. molbox RFM
Internal Pneumatic Schematic
– SYSTEM LEAK CHECK – CHECKING OFFSET AND STABILITY
molbloc-S operation

Close an isolation valve downstream or plug the exhaust of the flow system that is being tested (downstream of the molbloc and the DUT if the molbloc/molbox is being used to test another device).

Open an isolation valve upstream of the molbloc to allow the working pressure to pressurize the system.

Note

For systems with mass flow controllers (MFCs)

Keep in mind that the valves in most MFCs are not intended to provide a complete gas shutoff and so they may not be suitable to close off the test system. If an MFC is downstream of the molbloc and its downstream port is open to atmosphere, it is best to close the system by connecting a cap to the MFC outlet fitting or by connecting a shutoff valve downstream. If the MFC valve is closed (most MFCs have normally closed valves) when the operating pressure is applied from the upstream side, most of the gas will be stopped by the MFC valve and will not immediately fill the volume between the MFC valve and the downstream cap or valve. If this happens, the gas may leak by the MFC valve to fill this volume during the test and cause a pressure decay and an apparent system leak. The solution is to send a setpoint signal to the MFC to open the MFC valve while pressurizing the system. Then close the MFC valve (remove the setpoint signal) after the system is pressurized to avoid heating of the test gas by the energized valve.

Next, close the isolation valve upstream of the molbloc so the gas supply is no longer open to the system being checked. Once the pressure has had time to stabilize, press **[ENTER]**.

The next display is:

```
ENTER to start
60 s leak check
```

Press **[ENTER]** to begin the test

The next display is:

1. The average pressure from the two molbox RFM absolute RPTs.
2. Current absolute pressure measurement in active pressure unit of measure.
3. SYSTEM LEAK CHECK count down in seconds.

```
1
↓
199.16 kPa a
leak testing 60s
↑      ↑
2      3
```

Press **[ESCAPE]** to abort the leak test.

Pressing **[ENTER]** while the test is in progress restarts the test and reset the leak test timer.

When the test is complete, a test results screen is displayed:

1. The total change in average pressure over the test interval.
2. The currently selected pressure unit of measure.
3. Average rate of pressure change, per second, during the test.

```
1      2
↓      ↓
ΔP -0.0720 kPa
Rate -0.0012 kPa/s
      ↑
      3
```

Since flow systems using molbloc-S will may use widely varying flow rates and tubing sizes, and test volumes may be quite large, it is difficult to predict what size pressure rate of change is acceptable to avoid significant flow errors. Your best guide may be to run the SYSTEM LEAK CHECK often with your hardware, find a typical rate of change which represents a sound setup, and attempt to match that rate each time. In any case, you should be able to achieve a rate of change smaller than 0.01 % / second of the absolute line pressure.

If you observe a relatively large leak rate and are unable to locate a leak in the flowpath components, check or replace the upstream and downstream molbloc to molbox pressure tubes and their connectors and retry the test. They are a critical part of the pneumatic system and if a significant leak is present in these tubes, it will cause an error in flow measurement.

3.4.4.4 <4AutoZ>

○ PURPOSE

To offset the molbox RFM absolute reference pressure transducers (RPTs) relative to a reference value in order to compensate for possible changes in RPT zero between full recalibrations.

⚠ Caution

Improper use of the AutoZ function can cause out of tolerance pressure measurements. AutoZ should be used only by qualified personnel for the purpose of rezeroing the molbox RFM reference pressure transducer absolute pressure measurement function.

Note

The AutoZ function has no effect on the microrange (differential) RPT measurement (if present).

○ PRINCIPAL

AutoZ Purpose and Principle

The main component of the change over time of the molbox RFM RPTs is change in zero or offset, independent of span. Offsetting or “rezeroing” molbox RFM RPTs relative to a reference between recalibrations allows measurement uncertainty specifications to be maintained with less frequent full calibrations. The molbox RFM AutoZero function (AutoZ) provides full on-board support for the rezeroing process to simplify its application by the user.

The AutoZero function uses three values:

1. $P_{std,0}$: The absolute pressure value indicated by the AutoZ reference, the device that is acting as the reference relative to which to offset the RPT.

The pressure at which AutoZ is performed is normally atmospheric pressure and the $P_{std,0}$ value can be supplied a) by manual entry, or b) automatically from a **FLUKE CALIBRATION** RPMx Reference Pressure Monitor.

2. $P_{u,0}$: The absolute pressure reading of the RPT, with no AutoZ offset, at the time AutoZ is performed.
3. P_{offset} : The difference between the absolute pressure reading of the RPT with no AutoZ offset ($P_{u,0}$) and the indication of the AutoZ reference ($P_{std,0}$):

$$P_{offset} = P_{u,0} - P_{std,0}$$

P_{offset} represents the change in zero of the RPT relative to the AutoZ standard ($P_{std,0}$).

The AutoZ function manages the determination, storage and application of P_{offset} for both molbox RFM RPTs in absolute mode. The AutoZ handles both molbox RFM RPTs simultaneously as they are of the same range and always used together.

The source of $P_{std,0}$ must be an absolute pressure, nominally atmospheric pressure, with uncertainty significantly better than that of the RPT that is being AutoZeroed (see Section 1.2.2). This can be accomplished with a variety of digital barometers or with a piston gauge able to set absolute pressure.

When the RPTs are used with AutoZ ON, absolute pressure is calculated as:

$$P_{abs} = P_{u,0} - P_{offset}$$

When RPTs are used with AutoZ OFF, P_{offset} is ignored.

When the RPT is calibrated, P_{offset} is set to zero. P_{offset} is then redetermined at regular intervals using the AutoZ function. The most recent value of P_{offset} is applied to the RPT reading to correct for change in zero over time.

Recommendations for the Use of the AutoZ Function

The AutoZ function provides a powerful and easy to use tool for improving the stability over time of molbox RFM RPTs and maximizing the recalibration interval by compensating for change in zero between full recalibrations. The following simple recommendations will help assure that you use this feature to best advantage.

- Always leave AutoZ ON when operating **if** the AutoZ routine has been run regularly using a valid atmospheric reference.
- Run AutoZ to update P_{offset} only when a reference whose measurement uncertainty is known to be significantly better than that of the molbox RFM RPTs is available. Though it may not be practical and generally is

not necessary, the best possible reference with which to run AutoZ in absolute measurement mode is a gas operated piston gauge (such as a Fluke Calibration PG7601) applying an absolute pressure near atmospheric pressure to the molbox RFM test port. The best day to day reference is a properly calibrated Fluke Calibration RPM4 with a BA100K RPT interfaced directly as an external device to the molbox RFM COM2 port.

- Allow the molbox RFM to stabilize at atmospheric pressure and ambient temperature for 10 to 15 minutes before running AutoZ.

Note

If AutoZ is on, the AutoZ value will be applied while running the calibration of molbox RPTs and an AutoZ indication is included in the run calibration screen (See Section 5.2.4.1).

○ OPERATION

To access the molbox RFM AutoZ function press [TARE], <4AutoZ>. The display is:

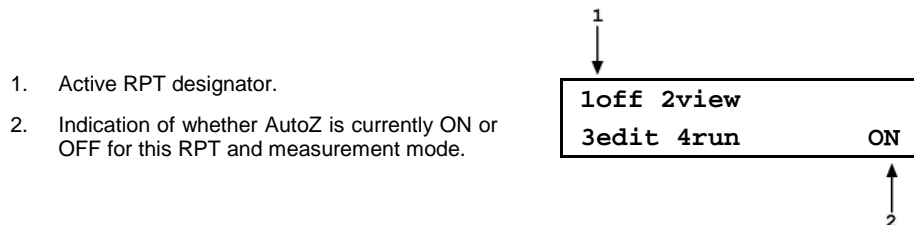

- Select <1off> (or <1on>) to change the AutoZ status.
- Select <2view> to view the current values of P_{offset} for the two RPTs.

Note

P_{offset} should be zero when the molbox RFM is new or has just been calibrated.

- Select <3edit> to edit the values of P_{offset} .

Note

The value of P_{offset} is always displayed and entered in Pascal (Pa).

- Select <4run> to run the AutoZ routine which determines and activates P_{offset} values by measurement of $P_{\text{std},0}$ (see Section 3.4.4.4.2).

3.4.4.4.1 Edit AutoZ

⚠ Caution

The edit AutoZ function should be used with great caution as entering inappropriate values and turning ON AutoZ may result in out of tolerance measurements. In normal operation, the value of the AutoZ offset, P_{offset} , should be changed using the run AutoZ function (see Section 3.4.4.4.2). Before editing P_{offset} , (see Section 3.4.4.4, PRINCIPLE).

To edit the current P_{offset} values, press [TARE], <4AutoZ>, <3edit>. The display is:

1. Edit field for the value of P_{offset} of the upstream (1, Hi) RPT.
2. Edit field for the value of P_{offset} of the upstream (1, Hi) RPT.

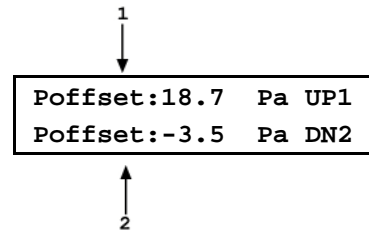

Edit the P_{offset} value(s) as desired and press [ENT] to activate the new value(s). Press [ESC] to abandon changes.

Note

The value of P_{offset} is always displayed and entered in Pascal (Pa).

3.4.4.4.2 Run AutoZ

Run AutoZ is the function by which the current RPT reading is compared to a reference, $P_{std,0}$, at atmospheric pressure to determine a new value of P_{offset} . The value of P_{offset} is then used by AutoZ to automatically correct the RPT for possible change in zero over time (see Section 3.4.4.4, PRINCIPLE).

There are 3 program limits on the entry of $P_{std,0}$ in place to reduce the possibility of erroneous entries from either method, limits given in kPa absolute but directly convertible to the current unit of measure:

- 1) The entry must be within the limits of 70-110kPa absolute.
- 2) If the entry is => 0.025% of nominal full scale from the current reading of either RPT, the molbox RFM will warn that the value is high for the specific transducer(s) but accept the entry.
- 3) If the entry is => 0.05% of nominal full scale from the current reading of either RPT, the molbox RFM will warn that the value is too high for the specific transducer(s) and reject the entry.

In the case of 3), the pressure calibration of the molbox RFM RPT's or the accuracy or calibration of the pressure reference used to obtain $P_{std,0}$ should be double-checked.

While an entry within the limits of 1) or 2) is acceptable, if running AutoZ results in a value of Poffset that is greater than ± 0.02 % FS of the span of the RPT that is being AutoZeroed, the RPT and/or the reference used as the source of $P_{std,0}$ may be out of tolerance or the AutoZ process may have been faulty. Before activating a new Poffset greater than ± 0.02 % FS of the active RPT, check to be sure that both the RPT and the reference were in good working order, properly vented to stable atmospheric pressure, at the same height, and reading in the same pressure units when AutoZ was run. A good laboratory practice would be to keep a log of the resulting AutoZ P_{offset} values for the two transducers over time to look for trends.

To access run AutoZ, press [TARE], <4AutoZ>, <4run>. The display is:

1. Selection of source of $P_{std,0}$ reference to which to AutoZ.

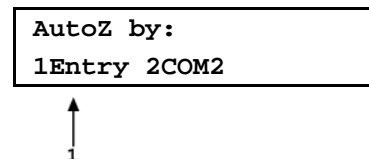

Selecting <1Entry> allows the value of $P_{std,0}$ to be entered from the front panel keypad.

Selecting <2COM> allows the value of $P_{std,0}$ to be read automatically from a Fluke Calibration RPMx connected to molbox RFM's COM2 communications port.

When AutoZ is run, the molbox RFM internal valves are actuated to connect both molbox RPTs to the Hi port on the molbox RFM rear panel (see Figure 21 in Section 5.2.4.1). Be sure the Hi port is fully open to atmosphere when running AutoZ. Note that the molbox RFM quick connectors and molbox to molbloc pressure lines are self sealing and therefore DO NOT open to atmosphere unless a quick connector stem is inserted. Use a quick connector stem (Fluke P/N 3068652), equivalent to Swagelok SS-QM2-S-200) supplied with the molbox RFM accessories to open the port to atmosphere.

Note

- **Allow the molbox RFM to stabilize at atmospheric pressure and ambient temperature for 10 to 15 minutes before running AutoZ.**
- **If running AutoZ results in a value of P_{offset} that is greater than ± 0.025 % FS of the span of the RPT that is being AutoZeroed, the RPT and/or the reference used as the source of $P_{\text{std},0}$ may be out of tolerance or the AutoZ process may have been faulty. Before activating a new P_{offset} greater than ± 0.025 % FS of the active RPT, check to be sure that both the RPT and the reference were in good working order, properly vented to stable atmospheric pressure, at the same height, and reading in the same pressure units when AutoZ was run.**
- **When the run AutoZ selection is made, if a HEAD correction is currently active (see Section 3.6.8) the head correction is momentarily disabled while running AutoZ to avoid “zeroing out” the head value.**
- **The value of P_{offset} is always displayed and entered in Pascal (Pa).**

Run AutoZ by Entry

AutoZ by entry allows the value of $P_{\text{std},0}$ (see Section 3.4.4.4, PRINCIPLE) to be entered directly from the molbox RFM front panel. This provides a simple way of AutoZeroing relative to an independent reference device such as a house barometer that does not interface directly with molbox RFM.

To access run AutoZ by entry press [TARE], <4AutoZ>, <4run>, <1Entry>. The display is:

1. Real time reading (without head correction) of upstream (1, Hi) RPT in unit of measure on line 2.
2. Real time reading (without head correction) of downstream (2, Lo) RPT in unit of measure on line 2.
3. Entry field for the value of $P_{\text{std},0}$ in the current pressure unit of measure.

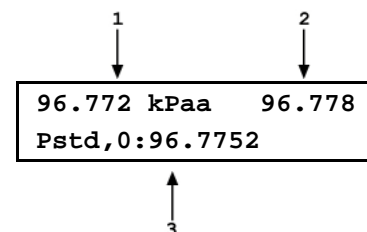

Enter the value of the AutoZ reference ($P_{\text{std},0}$) in the same unit of measure as the display and press [ENT]. molbox RFM logs the readings and calculates a new AutoZ offset value. The next display is:

1. Current/previous value of P_{offset} for the upstream (1, Hi) RPT.
2. Current/previous value of P_{offset} for the downstream (2, Lo) RPT.
3. New value of P_{offset} for the upstream (1, Hi) RPT for the AutoZ that was just run.
4. New value of P_{offset} for the downstream (2, Lo) RPT for the AutoZ that was just run.

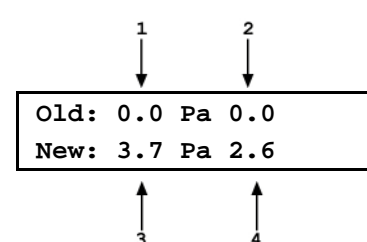

Press **[ENT]** to activate the new values of P_{offset} or **[ESC]** to start over with entry of a new AutoZ reference ($P_{std,0}$) value.

Note

The value of P_{offset} is always in Pascal (Pa). The value of $P_{std,0}$ is entered in the current pressure unit of measure.

Run AutoZ by COM2

AutoZ by COM2 allows a Fluke Calibration RPMx Reference Pressure monitor connected to the molbox RFM COM2 to act as the AutoZ reference (source of $P_{std,0}$) (see Section 3.4.4.4, PRINCIPLE). The RPMx is read and the new P_{offset} is calculated automatically.

To access run AutoZ by COM2 press **[TARE]**, **<4AutoZ>**, **<4run>**, **<2COM2>**.

Note

For molbox RFM to communicate with an RPMx connected to its COM2 port, the molbox RFM and the RPMx RS-232 interfaces must be set up properly (see Section 3.6.6.1). If, the molbox RFM is unable to locate an RPM ON COM2 when running AutoZ by COM2, it times out after 6 seconds and displays an error message.

If molbox RFM is able to communicate with an RPMx on its COM2 port, the display is:

1. Real time reading (without head correction) of upstream (1, Hi) RPT in unit of measure on line 2.
2. Real time reading (without head correction) of downstream (2, Lo) RPT in unit of measure on line 2.
3. Real time reading of the RPMx connected to molbox RFM COM2 to provide the value of AutoZ P_{offset} .

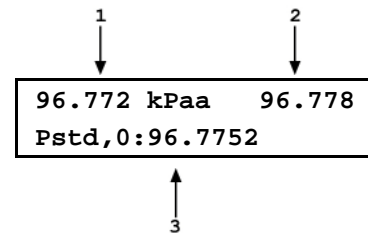

Observe the pressure outputs verify that they are stable. A 10 to 15 minute wait, after venting, is recommended before running AutoZ. When ready, press **[ENT]** to cause AutoZ to run. molbox RFM logs both RPT readings and calculates a new AutoZ offset value. The display is:

1. Current/previous value of P_{offset} for the upstream (1, Hi) RPT.
2. Current/previous value of P_{offset} for the downstream (2, Lo) RPT.
3. New value of P_{offset} for the upstream (1, Hi) RPT for the AutoZ that was just run.
4. New value of P_{offset} for the downstream (2, Lo) RPT for the AutoZ that was just run.

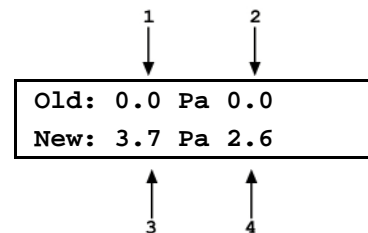

Press **[ENT]** to activate the new values of P_{offset} or **[ESC]** to start over.

Note

The value of P_{offset} is always displayed and entered in Pascal (Pa).

3.4.4.5 <5BPR> (molbloc-S Operation only)

○ PURPOSE

To quickly measure the molbloc-S upstream and downstream pressure and calculate and display the BPR (back pressure ratio) when molbox RFM is in a molbloc-S BPR mode which would not otherwise measure the BPR.

Note

The <5BPR> menu selection is only present during molbloc-S operation.

○ PRINCIPAL

molbox RFM uses the back pressure ratio, or BPR (the ratio of the molbloc-S downstream absolute pressure to the upstream absolute pressure) to determine whether the flow through the throat of the molbloc-S venturi nozzle is critical and flow measurements within predictable uncertainty limits can be made with molbloc-S (see Section 3.1.2). When operating molbox RFM with molbloc-S, the user may select different BPR monitoring modes (see Section 3.6.9). The BPR function allows the user to measure and display BPR directly at any time regardless of the current BPR mode.

○ OPERATION

Select [TARE], <5BPR>. The display is:

1. The current pressure read by the upstream (left) and downstream (right) RPTs without taking into account the current tare value. These are untared readings in the current pressure unit of measure.
2. The current BPR (ratio of downstream to upstream absolute pressure).

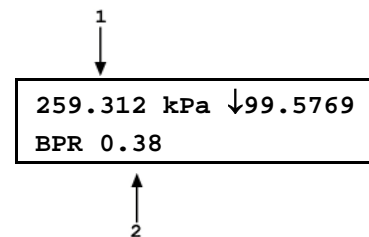

Press [ENTER] or [ESCAPE] to exit the BPR function and return to the previous RUN screen and BPR mode.

3.4.5 [P&T] (Pressure and Temperature)**○ PURPOSE**

To provide continuous display of the pressures measured by molbox RFM, the Reynolds number of the flow through the molbloc, the temperature of the molbloc and other pressure measurement information depending on whether a molbloc-L or molbloc-S is connected to molbox RFM.

○ PRINCIPLE

molbox RFM continuously measures pressures and molbloc temperature and uses these measurements to calculate flow.

The pressure at the molbloc upstream and downstream ports is read by two absolute Reference Pressure Transducers (RPTs). In molbloc-L operation, the flow is calculated from the differential pressure across the molbloc. The differential pressure is calculated as the difference between the two absolute RPT measurements (upstream - downstream) and is displayed in the pressure screen. If the molbox RFM is equipped with the microrange option, differential pressure below 12.5 kPa (1.8 psi) is measured by the microrange option's low differential pressure RPT.

In molbloc-S operation, the flow is calculated from the molbloc-S upstream pressure. The upstream pressure may be read by either one or both of the RPTs, depending on which BPR mode is used (see Section 3.6.9). When molbox RFM is in a valve state called BPR OFF, the molbloc-S downstream pressure is not measured and both RPTs are used to measure the molbloc-S upstream pressure. Their readings are averaged to reduce the uncertainty of the molbloc-S upstream pressure measurement. An indicator is used next to the "downstream" RPT value to show whether the RPT is currently measuring the molbloc downstream or upstream pressure. Whenever the molbloc-S downstream pressure is measured, the BPR is calculated and shown in the P&T pressure screen. When both RPTs measure the upstream pressure (BPR OFF mode), the indicated pressure for both RPTs is adjusted to equal the average of the two using the dynamic tare and BPR is no longer displayed.

Since the displays and operation of the P&T pressure screen are different for molbloc-L and molbloc-S operation, they are described separately in the ○ OPERATION sections below.

For temperature measurement, two Platinum Resistance Thermometers (PRTs) are embedded in each molbloc. These are connected to the molbox RFM by the molbox to molbloc cable. The molbox RFM ohmic measurement system reads the resistance of the PRTs and calculates molbloc temperature.

molbox RFM continuously calculates the Reynolds number of the flow through the molbloc. molbox RFM's current pressure and temperature readings as well as the Reynolds number of the current flow can be displayed using the P&T function.

○ OPERATION – molbloc-L Operation

Press [P&T] from any run screen. The display is:

1. Pressure read by the upstream RPT (left), the downstream RPT (right) and the pressure unit of measure (middle).
2. The current differential pressure in the current pressure unit of measure. <DP> indicates the value is differential pressure. <mDP> indicates the measurement is from the microrange differential RPT (if present).
3. Current Reynolds number of the flow through the molbloc.

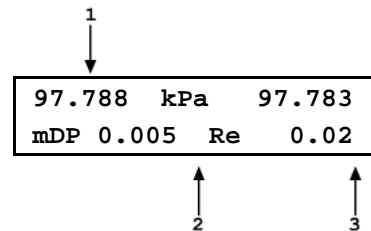

Pressing [P&T] again or the [+/-] key toggles between the pressure screen and the temperature screen:

1. The average molbloc temperature in the current unit of measure (upstream + downstream/2).
2. The temperature measured by the upstream molbloc platinum resistance thermometer in the current unit of measure.
3. The temperature measured by the downstream molbloc platinum resistance thermometer in the current unit of measure.

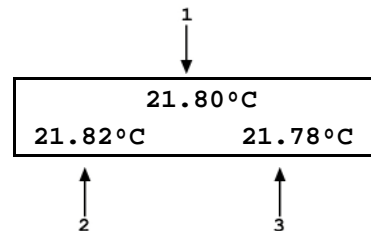

To leave the P&T function and return to the MAIN run screen, press [ESCAPE].

Note

To change the pressure and/or temperature unit of measure, see Sections 3.5.2 and 3.5.3.

○ OPERATION – molbloc-S operation

1. The current pressure read by the upstream (left) and downstream (right) RPTs and the current pressure unit of measure (middle). In BPR OFF or Auto modes, tare is automatically applied to these readings. In BPR ON mode, tare is never applied.
2. Arrow to indicate which pressure is being read by the “downstream” RPT. Down arrow indicates downstream pressure, Up arrow indicates upstream pressure.
3. The current BPR (ratio of downstream to upstream absolute pressure).
4. Current Reynolds number.

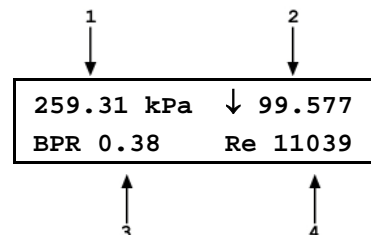

Pressing **[P&T]** again or the **[+/-]** key toggles between the pressure screen and the temperature screen:

1. The average molbloc temperature in the current unit of measure (upstream + downstream/2).
2. The temperature measured by the upstream molbloc platinum resistance thermometer in the current unit of measure.
3. The temperature measured by the downstream molbloc platinum resistance thermometer in the current unit of measure.

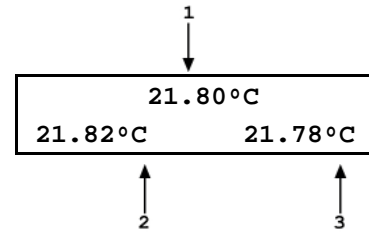

To leave the P&T function and return to the MAIN run screen, press **[ESCAPE]**.

Note

To change the pressure and/or temperature unit of measure, see Sections 3.5.2 and 3.5.3.

3.4.6 [DISPLAY]

○ PURPOSE

To select, from a variety of choices, the information that is displayed in the molbox RFM main run display.

○ PRINCIPLE

molbox RFM supports a variety of ADVANCED FLOW MEASUREMENT functions that are generally displayed on the second (bottom) line of the molbox RFM display. In summary, the available DISPLAY functions included are:

- RATE:** Calculates and displays the current rate of change of flow in current flow units/second (see Section 3.4.6.1). This function is a useful indication of the stability of the flow being measured. It is often used as a “go/no go” criterion for when to take data when comparing molbox RFM and a DUT (e.g., in a calibration).
- AVERAGE:** Calculates the average flow measurement over a user specified period of time and displays the average, the standard deviation about the mean and a countdown in seconds to the next average (see Section 3.4.6.2). This function is often used to filter out flow noise in an unstable system or to gather a corresponding sample when comparing molbloc/molbox measurements to another device with a long integration time (e.g., a volumetric flow standard). The magnitude of the noise is quantified by the standard deviation about the mean. A second screen allows the instantaneous flow values to be viewed during an averaging cycle.
- HI/LO:** Records and displays the maximum and minimum flows measured since HI/LO reset (see Section 3.4.6.3). This function is used to keep track of the minimum and maximum flow observed over a period of time or to monitor whether a flow min/max limit has been exceeded.
- TOTAL:** Totalizes the mass or volume flowed over a period of time (see Section 3.4.6.4). Used to measure total mass or volume over a period of time. Can be useful in calibrating or verifying a totalizing flow device, when comparing molbloc/molbox to a gravimetric standard or to add or remove a specific quantity of mass or volume to/from a system.
- UNIT:** Displays the measurement of flow through the molbloc simultaneously in a second flow unit (see Section 3.4.6.5). This function is convenient when working with an unfamiliar flow unit of measure to simultaneously display a familiar unit or any time a real time flow unit conversion is desired.

DEVIATION: Continuously calculates and displays the deviation, in % of reading, between the current flow measured by molbox RFM and a target flow defined by the user (see Section 3.4.6.6). This function is useful in quickly calculating the error of a DUT's measurement or control, or the evolution of flow around and/or away from a desired set point.

FREEZE: Captures and displays the instantaneous flow value measured by molbox RFM when the **[ENTER]** key is pressed (see Section 3.4.6.7). This function is useful to record the flow present at the time of an operator observed trigger event.

CLEAN: Blanks out the second line of the display (see Section 3.4.6.8). This function is used when a simple display of flow measured by the molbox RFM, without additional information, is desired.

○ OPERATION

To select a DISPLAY function, press **[DISPLAY]** from the MAIN run screen.

The display is:

1avg	2rate	3hi/lo	
4total	5unit	6dev	↓
7freeze	8clean		

The cursor is on the active DISPLAY function. Selecting a DISPLAY function returns to the MAIN run screen with the selected function active.

See Section 3.4.6, PRINCIPLE for a summary of DISPLAY functions and Sections 3.4.6.1 through 3.4.6.8 for detailed information on each DISPLAY function.

Note

- In molbloc-S operation, at times, the back pressure ratio, BPR, will be too high for molbox RFM to calculate a meaningful flow value. When this occurs, the top line of the run screen display always reads <BPR HI> and the bottom line shows the label <BPR> and the current measured BPR value. This display has priority over the appearance of the display functions described in this section, but the display will return to normal when the BPR returns to a usable level for molbloc-S measurements (see Section 3.1.2).
- The default DISPLAY function is RATE which causes the second line of the display to show <R> followed by the current rate of change of flow in current flow unit of measure per second (see Section 3.4.6.1).

3.4.6.1 <1Rate>

○ PURPOSE

To activate the RATE DISPLAY.

Note

See Section 3.4.6, PRINCIPLE.

○ OPERATION

To activate the RATE DISPLAY press **[DISPLAY]** and select **<1rate>**. Selecting **<1rate>** returns to the MAIN run screen with the RATE DISPLAY active.

With the RATE DISPLAY active, the MAIN run screen is:

1. Standard MAIN run screen top line.
2. Current rate of change of flow in current flow unit of measure per second.

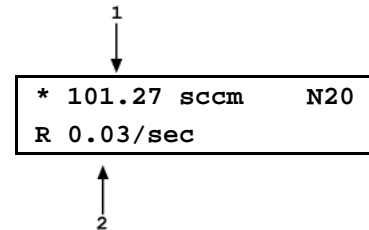

Note

- The RATE DISPLAY is different and separate from the stability setting that is used to set the stability criterion on which the *Ready/Not Ready* indication is based (see Sections 3.1.3). The RATE DISPLAY only causes the current rate of change to be displayed and has NO effect on the stability setting or the *Ready/Not Ready* condition.
- To go to a DISPLAY other than RATE, press **[DISPLAY]** and make a new DISPLAY choice.

3.4.6.2 <2AVG> (AVERAGE)

○ PURPOSE

To activate the AVERAGE DISPLAY and/or adjust the period of time over which averaging occurs.

Note

See Section 3.4.6, PRINCIPLE.

○ OPERATION

To access the AVERAGE DISPLAY, press **[DISPLAY]** and select **<2avg>**. The display is:

1. Edit field for averaging period in seconds. Default is 20. Minimum 3, maximum 999.

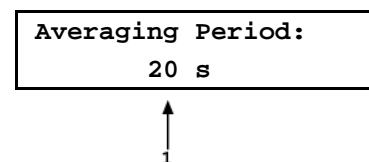

Edit the averaging time period if desired. Pressing **[ENTER]** returns to the MAIN run screen with the AVERAGE DISPLAY active.

With the AVERAGE DISPLAY active the MAIN run screen is:

1. Average flow measured over last completed averaging period.
2. Standard deviation of last completed averaging period.
3. Countdown in seconds until completion of on-going averaging period.

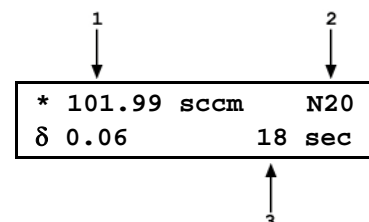

The AVERAGE DISPLAY has a second screen that allows the instantaneous flow readings to be viewed while an averaging cycle is running. Pressing [+/-] toggles between the MAIN run AVERAGE screen and the instantaneous values AVERAGE screen. The instantaneous AVERAGE screen is:

1. Instantaneous flow value at molbox RFM's normal integration rate.
2. Countdown in seconds until completion of on-going averaging period.
3. Current rate of change of flow in flow unit of measure/second..

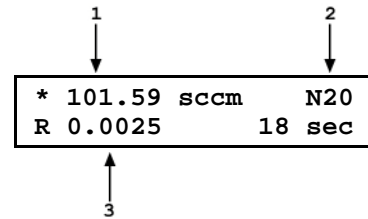

3.4.6.3 <3 Hi/Lo>

○ PURPOSE

To activate the HI/LO DISPLAY.

Note

See Section 3.4.6, PRINCIPLE.

○ OPERATION

To activate the HI/LO DISPLAY press [DISPLAY] and select <3hi/lo>. Selecting <3hi/lo> resets the HI/LO values and returns to the MAIN run screen with the HI/LO DISPLAY active. With the HI/LO DISPLAY active, the MAIN run screen is:

1. Standard MAIN run screen top line.
2. Highest flow observed since HI/LO reset.
3. Lowest flow observed since HI/LO reset.

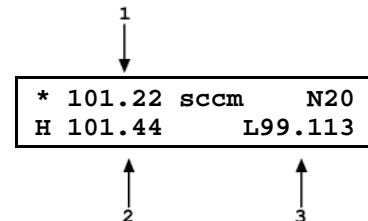

The HI/LO values change each time a new HI or LO flow value occurs. The HI/LO record can be reset at any time by pressing [ENTER] allowing a HI/LO reset without going back through the DISPLAY menu.

Note

- Changing the flow unit of measure, the gas, the K factor or running a TARE function while in HI/LO resets the HI/LO record.
- To go to a DISPLAY other than HI/LO, press [DISPLAY] and make a new DISPLAY choice.

3.4.6.4 <4TOTAL> (TOTALIZER)

○ PURPOSE

To activate the TOTALIZER DISPLAY.

Note

See Section 3.4.6, PRINCIPLE.

○ OPERATION

To activate the TOTALIZER DISPLAY, press **[DISPLAY]** and select **<4total>**. The display is:

1. Edit field for time over which to totalize (hh:mm:ss). Default period is 00:10:00; maximum 99:59:59.

```

Totalizing period:
      00:10:00
  
```



Edit the totalizing period as desired. Pressing **[ENTER]** returns to the MAIN run screen with the TOTALIZER DISPLAY active. With the TOTALIZER DISPLAY active the MAIN run screen is:

1. Standard MAIN run screen top line.
2. Total mass or volume accumulated over elapsed totalizing run time.
3. Units of measure of mass or volume (derived from the current flow unit) of the totalized value (see Table 12). The units of measure are not shown if the screen space is needed to show a large totalized value.
4. Elapsed totalizing time (hh:mm:ss). Always starts from zero and counts up until totalizing period elapses.

```

      1
      ↓
* 101.45 sccm   N20
Σ0.00 scc   00:00:00
      ↑   ↑   ↑
      2   3   4
  
```

Press **[ENTER]** to start totalizing. The elapsed time counter starts and the total mass or volume begins to accumulate. Totalizing continues until the set totalize period is complete. When the totalizing period is complete, molbox RFM sounds three beeps and displays the totalizing complete screen in which the total flow or volume and elapsed totalizing time are frozen with totalizing time NOT flashing.

To start a new totalizing run from the totalizing complete screen, press **[ENTER]**. This clears the previous total, resets to the totalizing timer and starts totalizing.

Note

- **Certain functions cannot be executed while totalizing. These functions include change K, change gas, change flow unit of measure, tare. If <Access restricted while totalizing> is displayed when a function key is pressed during totalizing, the function is one that cannot be executed while totalizing. To execute the function, abort the totalizing run or wait until after the run has completed. This feature is to avoid accidentally aborting or corrupting a totalizing run.**
- **To set a new totalizing time without going back through the [DISPLAY] menu, press [ENTER] and select <2new> from the TOTALIZER screen. To freeze a split total without stopping the totalizing run, press [ENTER] or [ESCAPE] while totalizing.**

Table 30. Flow Units and Corresponding Total Mass or Volume Units

FLOW UNIT	TOTAL MASS OR VOLUME UNIT
mol/s	mol
kg/s	kg
mg/s	mg
slh or slm	sl
sccm	scc
scfh or scfm	scf
Ulm	ul
Uccm	ucc
ucfm or ucfh	ucf
plm or plh	pl
pccm	pcc
pcfm or pcfh	pcf
lm or lh	l
ccm	cc
m3m or m3h	m3
cfm or cfh	cf

3.4.6.5 <5UNIT>

○ PURPOSE

To activate the UNIT DISPLAY.

Note

See Section 3.4.6, PRINCIPLE.

○ OPERATION

To activate the UNIT DISPLAY, press **[DISPLAY]** and select **<5unit>**. The unit of measure that will be used for the second line of the MAIN run screen display must then be selected. The unit selection process is identical to that of the **[UNIT]** function key (see Section 3.4.3). Once the unit has been selected operation returns to the MAIN run screen with the UNIT DISPLAY active.

With the UNIT DISPLAY active the MAIN run screen is:

1. Standard MAIN run screen top line.
2. Flow equivalent of the current measured flow in the alternate flow unit of measure.
3. Alternate flow unit of measure selected in UNIT DISPLAY.

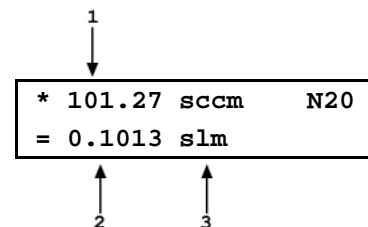

⚠ Caution

- The reference temperature setting for the user units (i.e., uccm and ulm) (see Section 3.4.3.3) and the temperature and pressure settings for volume units (see Section 3.4.3.4) apply to the units in the main UNIT selections as well as the UNIT DISPLAY selection. Therefore, it is not possible to simultaneously display user units or volume units with different reference temperatures and/or pressures. When you change the temperature or pressure setting for one type of unit, you change it for that type of unit wherever it is used. It is possible to show the difference between volumetrically based mass flow units at 0 °C and another temperature by choosing the “s” version (e.g., sccm) for 0 °C as the main unit and a user unit with a different reference temperature as the UNIT DISPLAY, or vice-versa.
- To go to a DISPLAY other than UNIT, press [DISPLAY] and make a new DISPLAY choice.

3.4.6.6 <6DEV>**○ PURPOSE**

To activate the DEVIATION DISPLAY and/or edit the deviation target.

Note

See Section 3.4.6, PRINCIPLE.

○ OPERATION

To activate the DEVIATION DISPLAY, press [DISPLAY] and select <6dev>. The display is:

1. Edit field to edit the target value from which the deviations is to be measured.

Target: 100.00 sccm

↑
1

Edit the desired target value. Pressing [ENTER] returns to the MAIN run screen with DEVIATION DISPLAY active using the entered target value.

With the DEVIATION DISPLAY active the MAIN run screen is:

1. Standard MAIN run screen top line.
2. Target value in current flow unit of measure.
3. Deviation of current flow from target value in % of reading.

* 100.53 sccm	N20
D 0.53 %	T 100.00

↓
1

↑
2

↑
3

Note

- Pressing [ENTER] from the MAIN run screen when the DEVIATION DISPLAY is active goes directly to the target editing screen. This allows the target value to be changed without going through the DISPLAY menu.
- The DEVIATION DISPLAY target value is the value from which % deviations (D) are measured by the DEVIATION DISPLAY following:

$$D = \frac{(\text{current flow} - \text{target})}{\text{target}} \times 100$$

- To go to a DISPLAY other than DEVIATION, press [DISPLAY] and make a new DISPLAY choice.

3.4.6.7 <7FREEZE>**○ PURPOSE**

To activate the FREEZE DISPLAY.

Note

See Section 3.4.6, PRINCIPLE.

○ OPERATION

To activate the FREEZE DISPLAY press [DISPLAY] and select <7freeze>. Selecting <7freeze> returns to the MAIN run screen with the FREEZE DISPLAY active.

With the FREEZE DISPLAY active, the MAIN run screen is:

1. Standard MAIN run screen top line.
2. Flow measured in the current flow units when [ENTER] was pressed (displays 0.00 by default when FREEZE DISPLAY is first activated).

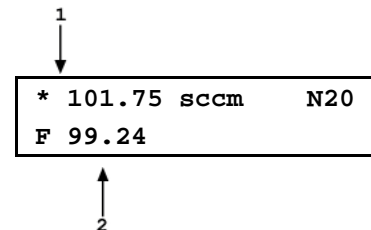

Pressing [ENTER] causes the current flow measured by molbox RFM to be captured and displayed.

Note

- If the flow measurement unit is changed while the FREEZE DISPLAY is active, the FREEZE value defaults back to zero.
- To go to a DISPLAY other than FREEZE, press [DISPLAY] and make a new DISPLAY choice.

3.4.6.8 <8CLEAN>**○ PURPOSE**

To activate the CLEAN DISPLAY.

Note

See Section 3.4.6, PRINCIPLE.

○ OPERATION

To activate the CLEAN DISPLAY press **[DISPLAY]** and select **<8clean>**. Selecting **<8clean>** returns to the MAIN run screen with the CLEAN DISPLAY active.

With the CLEAN DISPLAY active, the MAIN run screen is:

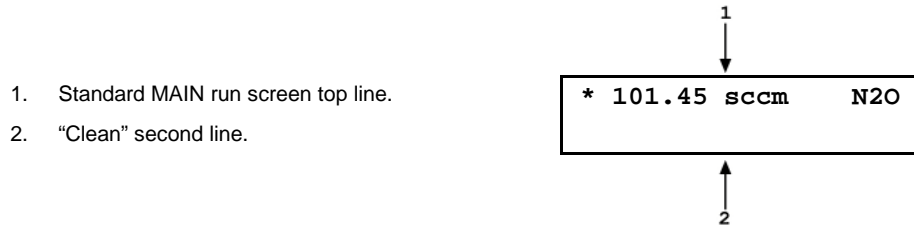

Note

To go to a DISPLAY other than CLEAN, press **[DISPLAY]** and make a new DISPLAY choice.

3.4.7 [MICRO] (Optional)

○ PURPOSE

To turn ON and OFF automatic operation of the optional MICRORANGE FLOW MEASUREMENT function.

○ PRINCIPLE

Note

Use of the microrange feature improves molbox RFM flow measurements while using molbloc-L only. Microrange has no effect and is disabled during molbloc-S operation.

The molbox RFM microrange option (if present) improves molbox RFM flow measurements when using a molbloc-L element below 10 % FS of its measurement range for models 1E1-L thru 3E4-L, and is required to achieve published specs for a 1E5-L. Flow measurement resolution and accuracy are enhanced by implementing a low differential pressure RPT which improves the resolution and accuracy of differential pressure measurement when differential pressure is below 12.5 kPa (1.8 psi). See Section 3.1.5 for microrange operational principles and Section 1.2.4.1.1 for microrange specifications.

In automatic microrange mode, use of the microrange option to improve flow measurement is optimized in a manner that is transparent to the user. In particular, the transition between the two different types of differential pressure measurement is smoothed out by weighted averaging of the differential values in a transition zone between 10 and 12.5 kPa differentials (1.5 to 1.8 psi).

The MICRO function turns ON and OFF the microrange option's automatic mode. With automatic microrange OFF, the microrange option differential pressure RPT measurements are not used at all (unless manual microrange is ON, see Section 3.6.7). With automatic microrange option ON, the differential pressure value used to calculate mass flow can come from the difference between the upstream and downstream RPTs, the microrange differential RPT or a combination of the two during the transition from one method to the other.

The microrange option can also be operated in a manual mode (see Section 3.6.7).

○ OPERATION

The MICRO function can be operated at any time from the main run screen. Pressing **[MICRO]** causes automatic microrange to turn ON if it is OFF and to turn OFF if it is ON. When **[MICRO]** is pressed, the molbox RFM displays a 3 second message indicating whether it is turning automatic microrange ON or OFF and then returns to the main run screen in the new condition. Automatic microrange ON is indicated by an **<m>** in the microrange status character of the main run screen. If molbox RFM is not equipped with the

microrange option, a 5 second message indicates that the microrange option is not installed. Don't confuse this message with <Access denied> which displays when the security level setting restricts [MICRO] key access (see Section 3.6.2).

⚠ Caution

Turning microrange OFF may reduce the accuracy of flow measurements below 10 % of the molbloc flow measurement range and lead to unexpected results.

Note

- **Automatic microrange option ON is indicated by an “m” in the microrange option designator character of the main run screen (top line, 6th character from the right). Microrange option OFF is indicated by a blank designator (see Section 3.2).**
- **Use of the MICRO function overrides the current setting of manual microrange option made by pressing [SPECIAL] and selecting <7micro> (see Section 3.6.7). If manual microrange is ON, pressing [MICRO] turns OFF manual microrange and turns ON automatic microrange.**

3.4.8 [molbloc]

○ PURPOSE

To initialize and/or rapidly identify a molbloc that is connected to molbox RFM.

○ PRINCIPLE

molblobs carry an EEPROM on which are stored the molbloc identification header, molbloc specific flow calibration coefficients and the zero offset of the molbloc platinum resistance thermometers. molbox RFM must have this information to accurately identify the molbloc to which it is connected and to correctly calculate flow through the molbloc. molbox RFM does not continuously read the information off the molbloc EEPROM. It reads and loads the information on the molbloc EEPROM each time it powers up. However, if the molbloc connected to the molbox is changed without turning the molbox RFM OFF and back ON, the new molbloc and the previous molbloc's calibration information will continue to be used.

The **[molbloc]** function key provides a rapid and simple way of causing the molbox RFM to load the molbloc to which it is connected and display a summary of its characteristics. This is useful when changing molblobs or to identify the molbloc that is currently in service.

Note

More complete molbloc information, including a list of gases for which the molbloc has specific calibration coefficients, can be accessed by pressing [SETUP] and selecting <4molbloc> (see Section 3.5.4).

○ OPERATION

Press the **[molbloc]** function key at any time from the main run screen. molbox RFM will take a moment to read the molbox EEPROM and then display a summary of the molbloc identification header including range designation, serial number and calibration date. This screen is displayed for 5 seconds before operation returns to the main run screen.

If molbox RFM is unable to establish communications with a molbloc, the display is:

molbloc not detected ENTER searches again
--

Pressing [ESCAPE] returns to the run screen. Pressing [ENTER] repeats the molbloc search just as if [molbloc] had been pressed again.

⚠ Caution

There is a risk of corrupting the molbloc EEPROM information when molbloc to molbox RFM electrical connections are made with the molbox RFM power ON. The recommended procedure is to power OFF the molbox RFM when making and breaking molbloc electrical connections. The SOFT POWER OFF does not remove power from the molbloc cable, so the power cord must be disconnected to power OFF the molbox RFM.

3.4.8.1 molbloc-L and molbloc-S size and Range Designations

Until mid-1999, molbloc-L elements (molbloc-S was not available at the time) were always identified by "Range". The molbloc-L "Range" is the molbloc's nominal full scale flow in Nitrogen (N₂) at an operating pressure of 250 kPa absolute. Actual molbloc ranges change with the molbloc pressure dependent calibration type and gas (see Section 1.2.4.1.2). Since mid-1999, in addition to nominal range, molbloc-L elements have been designated by size with a sizing code (see Table 31).

On molbloc-L EEPROMs, the molbloc is still identified by its nominal range rather than by its size. The identification of the molbloc displayed by **[SETUP]**, **<4molbloc>** identifies molbloc-L by both its nominal range and sizing code. molbloc-L size and range designation correspondence are given in Table 31.

Table 31. molbloc-L Size and Nominal Range Designations

molbloc "NOMINAL RANGE" DESIGNATION	molbloc-L SIZE DESIGNATION
10 sccm	1E1
50 sccm	5E1
100 sccm	1E2
200 sccm	2E2
500 sccm	5E2
1 slm	1E3
5 slm	5E3
10 slm	1E4
30 slm	3E4
100 slm	1E5

molbloc-S elements are also identified by size designations, each of which relate to a specific molbloc-S K_F value. molbloc-S flow ranges depend on calibration type and the pressure limitations of the application and molbox used. For information on the possible molbloc-S flow ranges with various operating pressures, see Section 1.2.4.2.2). molbloc-S size and K_F value correspondence are given in Table 32.

Table 32. molbloc-S Size Designation and Pressure to Flow Conversion Ratio (K_F)

K_F (sccm/kPa)	molbloc-S SIZE DESIGNATION
50	5E1-S
100	1E2-S
200	2E2-S
500	5E2-S
1 000	1E3-S
2 000	2E3-S
5 000	5E3-S
10 000	1E4-S

3.4.9 [RES]

○ PURPOSE

To set the resolution of molbox RFM's display of the flow through the molbloc and other flow display and entry values.

○ PRINCIPLE

The resolution with which the flow measured by molbox RFM is displayed can be adjusted. This feature can be used to reduce the resolution when lower precision measurements are being made and additional digits might confuse or distract the operator.

The resolution setting determines the number of digits with which flow is displayed. The desired resolution is calculated based on the nominal nitrogen gas full scale of the molbloc range in the current flow unit of measure and then rounded to the furthest digit to the right (i.e., resolution of 0.01 % on a 100 sccm molbloc is 0.01 sccm).

Note

The default (and maximum) resolution setting is 0.01 % of the molbloc full scale. The RES setting does not affect the resolution of flow information transmitted remotely. Remote information is always sent using flow resolution of 0.001% of molbloc full scale (0.0001% when microrange is active).

○ OPERATION

To access the resolution function press [RES].

Press the [←] to decrease the resolution and [→] to increase the resolution. Each press changes the resolution by a factor of 10. Once the desired resolution is displayed, press [ENTER] to set the selected resolution and return to the main run screen.

Note

The resolution setting affects the display of the measured flow as well as other indications and settings (e.g., quantities shown by the [DISPLAY] functions).

3.5 [SETUP]

○ PURPOSE

The [SETUP] key accesses a menu of commonly used molbox RFM functions and features that do NOT have direct function keys. These functions include:

- <1flowU>** To customize the flow unit choices available under **[UNIT]** (see Sections 3.5.1 and 3.4.3).
- <2presU>** To select/change the unit of measure in which molbox RFM displays pressure values (see Section 3.5.2).
- <3tempU>** To select/change the unit of measure in which molbox RFM displays temperature values (see Section 3.5.3).
- <4molbloc>** To initialize a molbloc when it is connected to molbox RFM and/or to identify the molbloc currently connected to molbox RFM (see Section 3.5.14).
- <5stab>** To change the stability limit that serves as the criterion for the flow *Ready/Not Ready* indication (see Sections 3.5.5 and 3.1.3).
- <6adj>** To set an *adder* and *multiplier* to adjust molbox RFM flow readings (see Section 3.5.6).

○ OPERATION

To access the SETUP menu, press **[SETUP]** from the MAIN run screen. The display is:

1flowU	2presU	3tempU
4molbloc	5stab	6adj

See Sections 3.5.1 to 3.5.6 for detailed information on each SETUP function.

3.5.1 <1FLOWU>

○ PURPOSE

To customize the selection of flow units of measure that are available for selection from the **[UNIT]** function key (see Section 3.4.3).

○ PRINCIPLE/OPERATION

See Section 3.4.3.5.

3.5.2 <2PRESU>

○ PURPOSE

To select/change the unit of measure in which molbox RFM displays pressure values.

○ OPERATION

To set the unit of measure in which molbox RFM displays pressure values, press **[SETUP]** and select **<2presU>**.

The display is:

Pressure unit type:
1SI 2other 3user

Select the unit type desired, then select the unit desired. After the unit selection, operation returns to the previous run screen with the selected pressure unit of measure active.

The pressure units of measure available are listed in Table 33.

Table 33. Pressure Units of Measure Available

<1SI>	<2Other>	<3User>*
<1Pa>	<1psi>	<1user>
<2kPa>	<2psf>	
<3mPa>	<3inHg>	
<4mbar>	<4inWa>	
<5bar>	<5kcm2>	
<6mmHg>		
<7mmWa>		

*3User: User defined unit.

Note

- The “user” unit is defined in terms of user units/Pa when the user unit is selected.
- See Section 7.1.1 for definition of the pressure unit conversions used by molbox RFM.

3.5.3 <3TEMPU>

○ **PURPOSE**

To select the unit of measure in which molbox RFM displays temperature values.

○ **OPERATION**

To set the unit of measure in which molbox RFM displays temperature values, press [SETUP] and select <3tempU>.

The display is:

Temperature unit: 1celcius 2fahrenheit

Select the desired unit. After the unit selection, operation returns to the run screen with the selected temperature unit active.

Note

See Section 7.1.2 for definition of the temperature unit conversions used by molbox RFM.

3.5.4 <4molbloc>

○ **PURPOSE**

To initialize a molbloc when it is connected to molbox RFM and/or to identify the molbloc currently connected to molbox RFM. To determine the gases with which the molbloc has been calibrated.

○ **PRINCIPLE**

molbox uses molbloc specific calibration information contained in the molbloc's EEPROM to determine whether it should operate in molbloc-L or molbloc-S mode and in its calculation of flow through the molbloc. For the molbox RFM to correctly calculate the flow through the molbloc, it must use the specific information for the molbloc that is currently connected. molbloc EEPROM information is read and stored by molbox RFM in the molbox power up sequence when it is turned on, or by selecting [SETUP], <4molbloc>.

The <4molbloc> function may be used any time there is a change in the molbloc connected to a channel to assure that molbox RFM uses the correct molbloc information on subsequent

measurements. The <4molbloc> function can also be used to display identifying information on the molbloc currently connected to the molbox RFM and to determine the gases with which the molbloc has been calibrated.

○ OPERATION

To access the molbloc function, press [SETUP], and <4molbloc>.

Operation is similar to operation of the [molbloc] direct function key (see Section 3.4.8). However, when in the molbloc identification screen, pressing [ENTER] causes a list of the gases for which the molbloc has specific calibration coefficients to be displayed. The gases are listed using their chemical abbreviations. **Error! Reference source not found.** After viewing, press [ESCAPE] to return to the current run screen.

3.5.5 <5stab>

○ PURPOSE

To change the stability limit that serves as the criterion for the flow *Ready/Not Ready* indication (see Section 3.1.3).

○ PRINCIPLE

molbox RFM continuously monitors the rate of change of flow through the molbloc to which it is connected and compares this rate to the stability limit to make a *Ready/Not Ready* determination (see Section 3.1.3). The STABILITY function allows the stability limit to be adjusted by the user to increase or decrease the stability required for a *Ready* (<*>) condition to occur.

Note

- The default stability limit is ± 0.5 sccm/second (or its equivalent in another flow unit). The stability limit value is automatically converted when the flow unit of measure is changed.
- The stability limit is separate and different from the RATE DISPLAY function (see Section 3.4.6.1) which allows the current rate of change of pressure to be displayed.

○ OPERATION

To adjust the stability limit press [SETUP] and select <5stab>. The display is:

1. Entry field for setting the desired stability limit in the current flow unit of measure. Recalls the default stability limit or the last stability limit set.

Flow stability test: 0.5 sccm/s



Edit the stability limit setting as desired. Pressing [ENTER] activates the new stability limit and returns to the current run screen.

Note

- The stability limit value is automatically converted when flow units of measure are changed.
- The [RES] setting affects the resolution of the stability limit value. If the stability limit display does not have enough resolution to set the desired value, use [RES] to adjust the resolution (see Section 3.4.9).

3.5.6 <6ADJ>

○ PURPOSE

To apply *adder* (FA) and *multiplier* (FM) coefficients to the flow measured by molbox RFM.

PRINCIPLE

The ADJ function gives the user the capability to adjust mass flow readings made by molbox RFM. This is accomplished by setting an *adder* and a *multiplier*.

The *adder* (FA) and *multiplier* (FM) adjust the displayed value of the flow through the molbloc as calculated by the molbox RFM following:

$$\text{corrected flow} = (\text{calculated flow} * FM) + FA$$

If a K factor is active (see Section 3.4.1), the *adder* and *multiplier* are applied to the calculated flow **before** the K factor is applied.

Using the Flow ADJ Function with molbloc-L to Handle a Gas Mixture

⚠ Caution

Use of ADJ to handle gas mixtures as described below is NOT valid with molbloc-S.

The flow ADJ function can be used to adjust flow readings to measure a gas mixture if the molecular weight and relative content of each component gas is known. Note that this method does not take into account the actual viscosity or compressibility factor of the gas mixture. The thermodynamic properties of the highest concentration gas are used. Therefore, the uncertainty in the measured flow is increased and the method is best when the highest concentration gas is greater than 90% of the mixture.

To use this feature, set the molbox RFM **[GAS]** (see Section 3.4.2) to the highest concentration gas, then adjust the flow *multiplier* by:

$$\frac{\text{molecular weight of the mix}}{\text{molecular weight of the gas selected on the molbox}}$$

For example, to adjust a gas mix that is 95 % Nitrogen (N₂) and 5 % Oxygen (O₂):

- ① Calculate the molecular weight of the mix.

$$N_2 \text{ molecular weight} = 28.016$$

$$O_2 \text{ molecular weight} = 31.999$$

$$\text{Mix molecular weight} = (28.016 \times 0.95) + (31.999 \times 0.05) = 28.215$$

- ② Select N₂, the highest concentration gas, as the molbox RFM gas.

- ③ Calculate: $\frac{\text{molecular weight of the mix}}{\text{molecular weight of the gas selected on the molbox}} = \frac{28.215}{28.016} = 1.0071$

- ④ Set flow *multiplier* in ADJ function to 1.0071.

○ OPERATION

To access the ADJ function press **[SETUP]** and select **<6adj>**. The display is:

Adder:	0	scm
Mult:	1.00000	

Edit the values as desired. Pressing **[ENTER]** returns you to the MAIN run screen with the edited *adder* and *multiplier* values applied.

When the <6adj> function is active (an adder or multiplier other than 0 and 1 is entered), there is an indicator on the top line of the main run screen. The indicator is an "A" in the character to the right of the molbox flow units. The indicator uses the same position as the "K" indicator (see section 3.2). If there is an ADJ and K active at the same time, the indicators will alternate, appearing every other update of the flow value (about once each second).

⚠ Caution

The flow *adder* and *multiplier* of the ADJ function, if different from 0 and 1, alter the flow readings made by the molbox. The ADJ function is always "ON". When using *adders* and *multipliers*, great caution should be taken to ensure that they are entered and changed correctly and that they are 0 and 1 if no *adder* or *multiplier* effect is desired. The ADJ function is restricted in all User Security Levels except "none" to protect against unintentional flow adjustment (See section 3.6.2).

3.6 [SPECIAL]**○ PURPOSE**

The **[SPECIAL]** key accesses a menu of molbox RFM functions and settings that are less commonly or not normally used in regular operation. These functions include:

- <1reset>** Access and execute various reset options (see Section 3.6.1).
- <2level>** Set user protection levels that restrict access to certain functions and to edit the user password (see Section 3.6.2).
- <3ul>** Set upper pressure limit alarm (see Section 3.6.3).
- <4cal>** View and adjust the molbox RFM pressure transducers and reference resistors (see Section 3.6.4).
- <5prefs>** Set display screen saver time, unit ID number and date and time (see Section 3.6.5).
- <6remote>** View and edit molbox RFM COM port (RS232) and IEEE-488 interface settings (see Section 3.6.6).
- <7log>** View and/or clear the molbox RFM event log (see Section 3.6.7).
- <8head>** Set the height for the pressure fluid head correction (see Section 3.6.8).
- <9BPR>** Set the back pressure ratio (BPR) mode (for molbloc-S operation only) (see Section 3.6.9).

○ OPERATION

To access the SPECIAL menu, press **[SPECIAL]** from the MAIN run screen.

The display is:

```
1reset 2level 3ul
4cal 5prefs 6remote ↓
7log 8head 9BPR
```

Select the desired function.

See Sections 3.6.1 to 3.6.9 for detailed SPECIAL function descriptions.

Note

Some screens (e.g., the SPECIAL menu) go beyond the two lines provided by the display. This is indicated by a flashing down arrow in the second line of the display. Press the [←] and [→] keys to move the cursor to access the lines that are NOT visible or directly enter the number of the hidden menu choice if you know it.

3.6.1 <1reset>

○ PURPOSE

To reset various molbox RFM settings to default or factory values.

○ PRINCIPLE

molbox RFM stores its user definable settings in non-volatile memory. The reset menu allows the user to selectively or completely reset these settings to factory defaults. Reset clears settings that the user may have made, and should be used only to restore the molbox RFM to a known state. molbox RFM will go through its reboot routine after any type of reset is executed.

○ OPERATION

To access the reset choices press [**SPECIAL**] and select <1reset>. The display is:

1sets 2units 3com 4cal 5all

Select the desired reset. After confirmation, the reset occurs. A reset always puts the molbox RFM through its start up routine as if power had been turned OFF and back ON.

See Sections 3.6.1.1 through 3.6.1.5 for detailed information on the specific reset choices.

⚠ Caution

RESET functions change user settings that affect flow measurement. If not used properly, resetting can cause out of tolerance measurements. RESET functions should only be used by qualified personnel with reference to this manual for information on the RESET functions.

3.6.1.1 <1sets>

○ PURPOSE/OPERATION

To access Reset - Sets, press [**SPECIAL**] and select <1reset>, <1sets>.

Reset - Sets clears and sets to default the user settings for various measurements. These include:

- Flow unit of measure to sccm (see Section 3.4.3).
- Pressure unit of measure to kPa (see Section 3.5.2).
- Temperature unit of measure to °C (see Section 3.5.3).
- Gas type to N2 (see Section 3.4.2).
- Stability criterion to 0.5 sccm (see Section 3.5.5).
- K factor to 1 (see Section 3.4.1).
- DISPLAY function to Rate (see Section 3.4.6.1).
- RPT *Tare* value to 0 (see Section 3.4.4.1).
- *Tare* preference to upstream pressure (see Section 3.4.4.1.1).
- Flow *adder* to 0 and flow *multiplier* to 1 (see Section 3.5.6).
- Resolution to 0.01 % (see Section 3.4.9).
- BPR mode to Auto (see Section 3.6.9)

3.6.1.2 <2units>**○ PURPOSE/OPERATION**

To access Reset - Units, press **[SPECIAL]** and select **<1reset>**, **<2units>**.

Reset - Units clears and sets to default all UNIT OF MEASURE functions. These include:

- Six flow units of measure selectable from **[UNIT]** to defaults (see Section 3.4.3).
- Flow unit of measure to sccm (see Section 3.4.3).
- Reference temperature for uxxx units of measure to 0 °C (see Section 3.4.3.3).
- Volume flow unit of measure conditions to molbloc for temperature and standard atmospheric pressure for pressure (see Section 3.4.3.4).
- Pressure unit of measure to kPa (see Section 3.5.2).
- User pressure unit coefficient to 1.00/Pa (see Section 3.5.2).
- Temperature unit of measure to °C (see Section 3.5.3).

3.6.1.3 <3com>**○ OPERATION/PURPOSE**

To access Reset - Com, press **[SPECIAL]** and select **<1reset>**, **<3com>**.

Reset - Com clears and sets to default the molbox RFM communications ports (see Section 3.6.6). This includes:

- COM1 and COM2
 Baud rate: 2 400
 Parity: Even
 Data bits: 7
 Stop bits: 1
 Terminating characters: **<CR>**, **<LF>**
- IEEE-488 (GPIB)
 Address: 10
 Terminating characters: **<CR>**, **<LF>**

3.6.1.4 <4cal>**○ PURPOSE/OPERATION****⚠ Caution**

Use special caution with this reset as critical calibration data may be altered.

To access Reset - Cal, press [**SPECIAL**] and select <1reset>, <4cal>.

Reset - Cal clears and sets to default the user calibration coefficients for molbox RFM Reference Pressure Transducers (RPTs) (see Section 5.2). If the molbox RFM has been recalibrated at any time since its original factory calibration, the recalibration adjustment was done using these user calibration coefficients. The RPT cal coefficient defaults are:

- Upstream and downstream absolute RPTs:
Adder 0
Multiplier: 1
Calibration Date: 19980101
- Microrange differential RPT:
Adder: 0
Multiplier: 1
Calibration Date: 19980101

Note

Reset - Cal has NO effect on the reference resistance values used to calibrate the molbox RFM internal ohmic measurement system (see Section 5.3).

3.6.1.5 <5all>

○ PURPOSE/OPERATION

To return molbox RFM to the original, as delivered factory condition. Performs the RESET - SETS, UNITS, COM and CAL functions and resets all other settable values to defaults.

To access Reset - All, press [**SPECIAL**] and select <1reset>, <5all>.

⚠ Caution

Use special caution with this reset as critical calibration data may be altered.

3.6.2 <2level>

○ PURPOSE

To set user protection levels that restrict access to certain functions and to edit the password required for changing user levels.

○ PRINCIPLE

molbox RFM's front panel user interface provides the means to access all molbox RFM user defined data, settings and functions including calibration data. Inadvertent, uninformed or unauthorized altering or deleting of data, settings and functions could require extensive reconfiguration by the user and might cause invalid readings. For these reasons, depending upon the application in which molbox RFM is being used, it may be desirable to restrict access to certain functions. The USER LEVEL function makes this possible. Four different levels of security are available: **none**, **low**, **medium** and **high**.

Access to changing security levels can be left open, or be protected by a password so that security levels can be used as a convenient way to avoid accidental changing of data or as a secured means of preventing tampering with molbox RFM settings.

3.6.2.1 Security Levels

The security levels are structured to support typical operating environments as follows:

- None** This level is intended for use only by the system manager and/or calibration facility. It allows access and editing in all areas including critical metrological information and other settings that affect measurement integrity.
- Low** Low security is designed to protect the specific metrological information and SYSTEM DIAGNOSTIC AND MAINTENANCE functions of the system against accidental alteration. It is intended for an advanced operator performing many different tasks. Low security is the default user level setting.
- Medium** Medium security is designed to protect specific metrological information in the system and to assure that the molbox RFM is operated using consistent operational parameters.
- High** High security protects all operating parameters. It is intended to minimize operator choices (e.g., to perform repeated identical tests under consistent conditions).

Caution

- **molbox RFM is delivered with the security level set to low to avoid inadvertent altering of critical internal settings but with unrestricted access to changing security level setting. It is recommended that the low security level be maintained at all times and password protection be implemented if control over setting of security levels is desired.**
- **If there is a risk of unauthorized changing of the security level, changing authority should be password protected (see OPERATION of this section).**
- **The High security level disables remote communications and returns an error message (“ERROR”) to all remote commands. All other security levels have NO effect on remote communications.**

The security levels are structured to support typical levels of operation. Specifically, the security levels prevent execution of the functions accessed by the key strokes marked by “•”.

Table 34. Security Levels - Functions NOT Executed Per Function/Level

KEYS	LOW	MEDIUM	HIGH
[K]			•
[GAS]			•
[UNIT]			•
[UNIT] (change temperature/pressure conditions)		•	•
[TARE] (access menu)			•
[TARE], <1tare>, <select tare pressure>		•	•
[TARE], <2purge>, (change purge time)		•	•
[TARE], <4AutoZ>, <1on/off>	•	•	•
[TARE], <4AutoZ>, <3edit>	•	•	•
[TARE], <4AutoZ>, <4run>		•	•
[P&T]			•
[DISPLAY]			•
[DISPLAY], (change times/target)		•	•
[MICRO]	•	•	•
[molbloc]			•
[RES]		•	•
[SETUP], <1flowU>		•	•
[SETUP], <2presU>		•	•
[SETUP], <3tempU>		•	•
[SETUP], <4molbloc>			•
[SETUP], <5stab>		•	•
[SETUP], <6adj>	•	•	•
[SPECIAL], <1reset>		•	•
[SPECIAL], <1reset>, <3com>	•	•	•
[SPECIAL], <1reset>, <4cal>	•	•	•
[SPECIAL], <1reset>, <5all>	•	•	•
[SPECIAL], <4cal>		•	•
[SPECIAL], <4cal>, <any 3edit>	•	•	•
[SPECIAL], <5prefs>			•
[SPECIAL], <5prefs>, <1ScrSvr>		•	•
[SPECIAL], <5prefs>, <2sound>		•	•

Table 35. Security Levels - Functions NOT Executed Per Function/Level
(Continued)

KEYS	LOW	MEDIUM	HIGH
[SPECIAL], <5prefs>, <3time> (make changes)	•	•	•
[SPECIAL], <5prefs>, <4ID>, <2edit>	•	•	•
[SPECIAL], <5prefs>, <5log> (clear log)	•	•	•
[SPECIAL], <6remote>			•
[SPECIAL], <6remote> (changes settings)		•	•
[SPECIAL], <7micro>		•	•
[SPECIAL], <8head>		•	•
[SPECIAL], <9BPR> (change mode)		•	•
Remote communications disabled			•

○ OPERATION

Note

molbox RFM is delivered with **NO** active password so access to the User Level menu is open. The user level is set to <1Low>. User levels can be changed freely until a password has been created. **RESET** functions (see Section 3.6.1) do not affect the password setting.

To access the USER LEVEL function, press [SPECIAL], <2level>.

If **NO** password yet exists or if the correct password has been entered, the display is:

```
1change user level
3edit password
```

Selecting <1change user level> brings up the restriction menu:

```
Restriction: 1none
2low 3medium 4high
```

Select the desired restriction level, or press [ESCAPE] to return to the current run screen.

Selecting <2edit password> displays the user password and allows it to be edited. Passwords can be up to six numbers in length and cannot start with a zero.

```
Password: pppppp
0 disables password
```

If **0** is entered as the password value, then the password is made inactive and a password will NOT be required to access the user level menu. This is the factory default with a security level of <2low>.

⚠ Caution

Once a password has been entered, the user level cannot be changed without reentering the password.

If there is an active password, the molbox RFM password entry screen appears.

The user must enter the user defined password or the factory **secondary** password to proceed. When a password is entered correctly, operation proceeds to the **<1change user level 2edit password>** screen.

RFM SN	nnn-xx
Password:	pppppp

The first field, **<nnnn>**, is the serial number of the molbox RFM, followed by a second field, **<xx>**, that counts the number of times that a **secondary** password has been used. The second field increments each time a **secondary** password is used. The third field, **<pppppp>**, is for normal password entry.

The factory **secondary** password is available in case the user password has been misplaced or forgotten. A factory **secondary** password can be obtained by contacting a Fluke Calibration Authorized Service Provider (see Table 34). The factory **secondary** password is different for each molbox RFM and changes each time it is used.

3.6.3 <3UL>

○ PURPOSE

To set an upper pressure limit above which molbox RFM will produce a warning, interrupt operation and isolate its internal pressure transducers.

○ PRINCIPLE

molbox RFM contains two, high precision reference pressure transducers (RPTs). These can be fatally damaged by large overpressures. The UL function uses molbox RFM's internal capabilities to attempt to protect the RPTs against overpressure. molbox RFM continuously monitors the pressure read by the RPTs. When the pressure passes the level set by the UL function, molbox RFM warns the operator by sounding an audible alarm. Beyond the UL limit there is an overpressure limit, which is not user selectable. If the pressure reaches the overpressure limit, molbox RFM uses its internal valves to isolate the RPTs.

○ OPERATION

To access the Upper Limit (UL) function, press **[SPECIAL]**, **<3ul>**. The display is:

The indication is of the current upper limit setting in the current pressure unit of measure. To specify a different pressure unit of measure, use **[SETUP]**, **<2presU>** (see Section 3.5.2).

Transducer Max Pres:
630.000 kPaa

To change the upper limit, enter the value desired (see max UL limits below) and press **[ENTER]**. The display returns to the MAIN run screen with the new upper limit in effect.

The maximum upper limit settings, which are also the default values, are 5 % above the molbox maximum operating pressure ranges. For molbox RFM, the max UL value is 630 kPa absolute (91 psia). The overpressure limit, which cannot be edited, is 660 kPa absolute (96 psia).

If the overpressure limit is exceeded, all molbox RFM isolation valves close and normal operation is interrupted. Normal operation can be reestablished by turning molbox RFM's power OFF and back ON or pressing **[ENTER]**. Be sure to correct the situation that led to the overpressure condition prior to rebooting molbox RFM or pressing **[ENTER]**. See Sections 3.6.3.1, 3.1.6 for additional details.

3.6.3.1 Upper Limit Alarm and Sequence

When the pressure reaches the upper limit, molbox RFM continues normal operation but sounds an audible alarm. The alarm ceases if the pressure is decreased below the upper limit.

When pressure reaches the overpressure limit, molbox RFM valves close, normal operation ceases and the display indicates:

670.250 kPa	651.780
OVERP! CHK & PWR DWN	

The top line indicates the current pressure measurement of the upstream (left) and downstream (right) RPTs. The bottom line is the over pressure warning. Pressure indications that are grossly out of scale generally indicate that the RPT(s) have been fatally overpressured.

Other menus can be observed but the MAIN run screen can not be accessed and no molbox RFM internal valves can be operated. To return the molbox RFM to normal operation, it must be turned OFF and back ON or press **[ENTER]** from the overpressure screen. When molbox normal operation is reestablished, its isolation valves will open. Be sure the situation that led to the overpressure condition is corrected before attempting to reestablish normal operation.

Note

- **The upper limit and overpressure functions are intended to use molbox RFM's features to the extent possible to protect the molbox RFM reference pressure transducers (RPTs) against overpressure. The system is not failsafe and an overpressure causing fatal damage to the RPTs can still occur. Ultimately, protection of the RPTs is the responsibility of the user. RPTs damaged by overpressure are not covered under the product warranty.**
- **molbox RFM continuously monitors for maximum pressure. Whenever the overpressure limit is exceeded, the pressure value reached, time and date are logged to a privileged location. This information can be of use in determining the events that led to an overpressure situation.**

3.6.4 <4cal>

To calibrate and adjust the molbox RFM reference pressure transducers and ohmic measurement system.

The CALIBRATION functions are considered part of molbox RFM maintenance and are therefore covered in the maintenance section of this manual (see Section 5).

3.6.5 <5prefs>

○ PURPOSE

To access a menu of molbox RFM internal operational preferences and functions. These include:

- **<scrSvr>**: View and change the SCREEN SAVER function (see Section 3.6.5.1).
- **<sounds>**: View and change valid and invalid keypad entry sound settings (see Section 3.6.5.2).
- **<time>**: View and edit the internal time and date settings (see Section 3.6.5.3).

- **<ID>**: View and edit the molbox RFM user ID (see Section 3.6.5.4).

○ OPERATION

To access the PREFS menu press **[SPECIAL]**, and select **<5prefs>**. The display is:

1ScrSvr 2sound 3time
4ID

See Sections 3.6.5.1 to 3.6.5.4 for detailed information on each PREFS function.

3.6.5.1 <1ScrSVR>

○ PURPOSE

To adjust the time setting of molbox RFM's SCREEN SAVER function.

○ PRINCIPLE

molbox RFM has a SCREEN SAVER function which causes the display to dim after a front panel key is NOT pressed for a certain amount of time. The default time activates the screen saver after 10 minutes. The time can be adjusted by the user or screen saving can be completely eliminated.

○ OPERATION

To access the SCREEN SAVER function, press **[SPECIAL]** and select **<5prefs>**, **<1ScrSav>**. Edit the time, in minutes, after which the screen saver will activate to dim the screen. Set zero to eliminate the SCREEN SAVER function.

Note

Setting screen saver time to zero eliminates the SCREEN SAVER function so that the display remains permanently at full brightness. The display may also be completely suppressed using the SOFT [ON/OFF] key (see Section 3.3.3).

3.6.5.2 <2Sound>

○ PURPOSE

To adjust or suppress the molbox RFM keypad valid and invalid key press sounds.

○ PRINCIPLE

molbox RFM provides audible feedback by a brief "beep" when a valid key press is made. Invalid key presses are indicated by a descending two tone "blorp". The frequency of this valid key press beep may be selected from three choices or all keypress sounds may be suppressed.

○ OPERATION

To access the key press SOUND function, press **[SPECIAL]** and select **<5prefs>**, **<2sound>**.

Select **<1none>** to suppress the valid and invalid key press sounds completely.

Select between **<2lo>**, **<3mid>** or **<4hi>** to adjust the valid key press tone frequency.

Note

The SOUND function only affects the valid key press tone.

3.6.5.3 <3Time>

○ PURPOSE

To view and edit the molbox RFM internal time and date settings.

○ OPERATION

To access the TIME function press **[SPECIAL]** and select **<5prefs>**, **<3time>**. The display is:

Edit: 1time 2 date
08:32:11 am 19980101

Select **<1time>** to edit the time. Edit hours, then minutes, then am/pm by pressing **[ENTER]** at each entry. Seconds go to zero when minutes are entered.

Select **<2date>** to edit the date. The date must be specified in YYYYMMDD format.

Note

The molbox RFM date and time are set to United States Mountain Standard Time in the final test and inspection process at the factory. If desired, use the DATE function to set your local time and date.

3.6.5.4 <4ID>

○ PURPOSE

To view or edit the molbox RFM user ID and to view the molbox RFM serial number.

○ PRINCIPLE

molbox RFM has a factory programmed serial number that is included on the product label on the bottom of the case and can be viewed in the introductory screen.

molbox RFM also allows the user to store a unique, twelve character, alpha numeric ID number. This feature is frequently used to assign an organizational control ID (e.g., an asset number, tool number, standard number, etc.). The ID function allows the ID number to be viewed and edited. It also displays the molbox RFM factory serial number.

○ OPERATION

To access the ID function press **[SPECIAL]** and select **<5prefs>**, **<4ID>**. Select **<1view>**, to view the current ID.

Select **<2edit>**, to edit the ID.

The ID has twelve characters. When the edit screen is opened, the cursor is on the first character. Numerical values can be entered directly from the keypad. In addition, the **[←]** and **[→]** keys can be used to toggle through a list of available alpha numeric characters. Holding the key slews through the characters. Character order going up (**[→]**) is: blank space, symbols, lower case letters, upper case letters, numbers. Press **[ENTER]** to select a character and move to the next character.

When a character is selected the cursor moves to the next character. To leave a blank character, press **[ENTER]** with the field for that character blank. Use this for the trailing characters if the ID being entered is less than twelve characters.

After the last of the twelve characters has been entered, the **<Save ID?>** option is offered. Select **<1no>** to return to the ID edit screen. Select **<2yes>** to save the edited ID.

Note

The ID can also be set remotely from a computer which is quite a bit more convenient than entering characters from the keyboard (see Section 4.3.4). The ID cannot be cleared or reset by any RESET functions (see Section 3.6.1).

3.6.5.5 <5log>

○ PURPOSE

To view and/or clear the molbox RFM event log.

○ PRINCIPLE

molbox RFM records to a log each time one of the following events occurs:

- An over-pressure occurs (see Sections 3.1.6, 3.6.3)
- A memory fault occurs

○ OPERATION

To view the event log press [SPECIAL] and select <5prefs>, and then <5log>. The oldest logged event appears. Pressing [ENTER] steps through the logged events from the oldest to the most recent and ending with the option to clear the log <Yes> or <No>.

If NO events have been logged: <End of log> displays.

3.6.6 <6remote>

○ PURPOSE

To configure the molbox RFM COM1, COM2 and IEEE-488 communication ports. To test COM1 and COM2 communications.

○ PRINCIPLE

The molbox RFM has two RS232 communications ports referred to as COM1 and COM2 and a single IEEE-488 port. COM1 and the IEEE-488 port are for communicating with a host computer (see Section 4.1). COM2 is reserved for communicating with an external device (e.g., a multimeter, second molbox, MFC controller, etc.). These ports can be set up from the molbox RFM front panel.

molbox RFM provides a self-test for its RS232 communication ports. The self-test allows verification that the molbox RFM RS232 ports (COM1 and COM2) are operating properly and that a valid interface cable is being used.

The RS232 test has two steps:

- ① COM1 sends a message to COM2.
- ② COM2 sends a message to COM1.

In each step, molbox RFM checks the message received at the receiving COM port. If the receiving COM port times out or receives an incorrect message, that step of the test fails.

○ OPERATION

To access the port configurations, press [SPECIAL] and select <6remote>.

Select <1COM1>, <2COM2>, or <3IEEE-488> to view and/or edit that port's settings.

Press [SPECIAL] and select <6remote>, <4RS232test> to access the RS232 self-test.

3.6.6.1 COM1 and COM2

The COMx ports can be set for the specific settings required by the user. The settings are baud rate, parity, data bits and stop bits. The available options are:

Table 36. COM1 and COM2 Available Settings

BAUD RATE	300, 600, 1 200, 2 400, 4 800, 9 600, 19 200
PARITY	NONE, ODD or EVEN
DATA BITS	7 or 8
STOP BITS	1 or 2

The default COMx settings are **2400, E, 7,1** for both COM ports.

The molbox RFM appends a carriage return (<CR>) and a line feed (<LF>) to all messages that are sent out of the COM1 port to the host. It looks for a carriage return to terminate incoming messages and ignores line feeds. The user **MUST** wait for a reply to each message sent to the molbox RFM before sending another message to it (see Section 4.2.1).

3.6.6.2 IEEE-488

The IEEE-488 port address can be defined from 1 to 31. The default address is 10.

The molbox RFM sends a line feed (<LF>) and asserts the EOI line at the end of all transmitted messages. It looks for a line feed and/or assertion of the EOI line to terminate incoming messages (see Section 4.2.2).

3.6.6.3 RS232 Self-Test

The RS232 self-test is provided to check the molbox RFM COM ports and the interface cable independently of an external device or computer.

If you are having difficulty communicating with molbox RFM from a host computer using RS232, the RS232 self test can help establish that the molbox RFM COM1 port you are trying to communicate with and the interface cable you are using are good.

To run a self test of the RS232 ports (COM1 and COM2), press **[SPECIAL]** and select **<6remote>**, **<4RS232test>**.

The display prompts you to connect COM1 to COM2 using a standard pin-to-pin DB-9F to DB-9M RS232 cable (see Section 4.2.1.1).

Once the cable has been installed, press **[ENTER]** to run the self-test. The test is first executed in the COM1→COM2 direction and then in the COM2→COM1 direction.

If the COM1→COM2 test passes: **<PASSED>** displays briefly and the test proceeds to COM2→COM1.

If COM2→COM1 passes: **<PASSED>** is displayed briefly followed by the conclusion, **<molbox RFM RS232 test has PASSED>**.

If a test fails: Execution is suspended until **[ENTER]** is pressed.

Note

The molbox RFM RS232 test can fail for three reasons:

1. The RS232 cable being used is incorrect (see Section 4.2.1.1 for information on the correct cable).
2. COM1 and COM2 do NOT have the same serial communications settings and therefore cannot communicate together (see Section 3.6.6.1 to set the COM ports).
3. COM1 or COM2 is defective.

The reason for failed communications is almost always a cable or incorrect RS232 interface settings. Be sure that these are correct before concluding that a COM port is defective.

3.6.7 <7Micro>

○ PURPOSE

To turn ON and OFF manual operation of the OPTIONAL MICRORANGE FLOW MEASUREMENT function.

Note

See also Sections 3.1.5 and 3.4.7 for additional information on the optional microrange measurement option.

⚠ Caution

Manual microrange is intended for special uses of the microrange option as explained in PRINCIPLE of this section. Normal use of the microrange is in automatic operation using the MICRO function (see Section 3.4.7).

○ PRINCIPLE

The molbox RFM microrange option (if present) improves molbox RFM flow measurements below 10 % FS of the measurement range. See Section 1.2.4.1.1 for a complete description of microrange principles. The differences between automatic microrange and manual microrange are that in manual microrange:

The differential pressure value used to calculate flow is either 100 % difference between the upstream and downstream absolute RPTs (P1 - P2) or 100 % readings from the microrange differential RPT. No special transitioning from one method to the other is applied.

The current source of the differential pressure measurement used to calculate flow is indicated by the microrange option designator character in the main run screen (<d> when the source is the microrange differential RPT; <a> flashing when the source is the difference between the upstream and downstream absolute RPTs).

Pressing [SPECIAL] and selecting <7micro> allows manual microrange to be turned ON and OFF. With manual microrange OFF, the microrange option differential pressure RPT measurements are not used at all (unless automatic microrange is ON, see Section 3.4.7). With manual microrange option ON, the differential pressure value used to calculate mass flow is either the difference between the upstream and downstream RPTs if differential pressure is > 12.5 kPa (1.8 psi) or the microrange differential RPT if differential pressure is < 12.5 kPa (1.8 psi).

The microrange option can also be operated in **automatic** mode (see Section 3.4.7).

○ OPERATION

To access the MANUAL MICRORANGE function, press [SPECIAL] and select <7micro>.

The display is:

Manual microrange: 1off 2on

If the manual microrange option is not installed, this menu will not appear. An <Option not installed> message appears in its place.

Select <1off> or <2on>. Operation returns to the run screen with the manual microrange in the condition specified.

⚠ Caution

Turning the microrange option OFF may reduce the accuracy of flow measurements under 10 % of the flow measurement range and may lead to unexpected results.

Note

- Manual microrange option ON is indicated by <d> (option ON, using microrange differential RPT) or <a> flashing (option ON, not currently using microrange differential RPT) in the microrange option designator character of the main run screen (top line, 6th character from the right). Manual microrange option OFF is indicated by a blank designator or the <m> that indicates automatic microrange ON.
- Turning ON or OFF manual microrange by pressing [SPECIAL] and selecting <7micro> overrides the current setting of automatic microrange (see Section 3.4.7).

3.6.8 <8Head>

○ PURPOSE

To cause a pressure fluid head correction to be added or subtracted to the pressure measured by the molbox RFM reference pressure transducers in order to predict the pressure at height the height of the molbloc when the molbloc is at a level other than the molbox RFM's reference level.

○ PRINCIPLE

molbox RFM measures absolute and differential pressure in molbloc flow elements. The molbox RFM reference pressure transducers (RPTs) are calibrated with the height of the rear panel pressure quick connectors as the pressure reference level. Sometimes, when performing a calibration or test, the molbloc is at a different height than the molbox RFM's pressure reference level. This difference in height, frequently called **head**, can cause a significant difference between the pressure measured by the molbox RFM at its reference level and the pressure actually present at the molbloc at a different height. In this case, it is useful to make a head correction to the pressure measured by the molbox RFM in order to predict the pressure actually applied at a different height.

molbox RFM can calculate **head** pressures for all the gases it supports (see Section 3.4.2), over its working pressure range. The HEAD function allows the difference in height between the molbox RFM and the molbloc to be specified and causes the resulting head pressure to be added to the pressure measured at the molbox RFM rear panel quick connectors.

[SPECIAL], <8head>, is used to specify the height difference between the molbox RFM rear panel quick connectors and another height. Entering a height of zero turns the function off.

Note

Use of the HEAD function to assure in tolerance measurements is most important when using molbloc-S at high pressures. Specifying the head height within ± 3 in. (7.5 cm) is adequate to assure that, even in the worst case, the uncertainty on the head correction will be insignificant relative to the tolerance of the measurement.

○ OPERATION

To access the HEAD function, press the [SPECIAL], <8head>. The display is:

1. Entry field for head height.
2. Current molbox RFM gas selection.

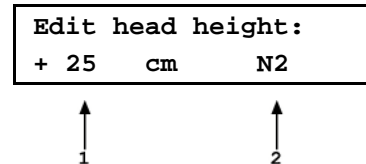

Edit the head height to the desired value. Press [ENT] to return to the run screen with the new head correction active. Press [ESC] to return with no changes.

Note

- The reference height of the molbox RFM pressure measurement is the middle of the molbox RFM rear panel pressure quick connectors. The head height should be entered as a positive value if the molbloc is higher than the molbox RFM and negative if it is lower.
- The head function is automatically disabled when running AutoZ (see Section 3.4.4.4.2) and in the calibration run screen (see Section 5.2.4.1)

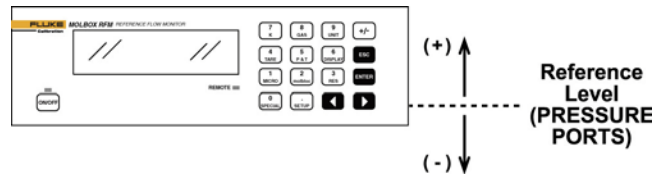

3.6.9 <9BPR>

○ PURPOSE

In molbloc-S operation, to select the molbox RFM BPR (back pressure ratio) measurement mode.

○ PRINCIPLE

When molbloc-S elements are used with molbox RFM, the RPT which is normally used to read molbloc downstream pressure, may be pneumatically connected to either the molbloc-S nozzle's upstream or downstream pressure, by molbox RFM internal valving. The two RPTs are used to simultaneously measure upstream pressure when possible to minimize the uncertainty on molbloc-S upstream pressure measurement by averaging the two RPT readings. The upstream absolute pressure is the most critical measurement for calculation of the flow through molbloc-S.

Measurement of molbloc-S downstream pressure is only necessary to monitor the BPR (molbloc back pressure ratio). The value of BPR indicates whether the flow through the molbloc-S has achieved the necessary critical flow condition (see Section 3.1.2).

When the molbox RFM internal valves are positioned to connect one RPT upstream and the other downstream of the nozzle to determine BPR, the valve state is referred to as BPR ON (see Figure 11).

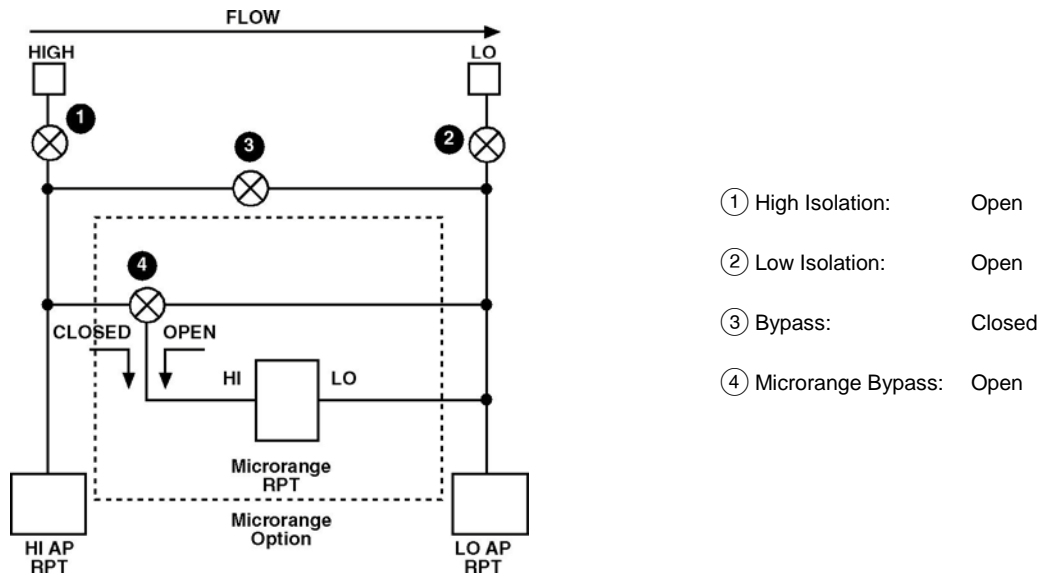

Figure 12. molbox RFM
Internal Pneumatic Schematic –
molbloc-S OPERATION, BPR ON

When the molbox RFM internal valves are positioned to allow both RPTs to measure the molbloc-S upstream pressure, the valve state is referred to as BPR OFF (see Figure 12).

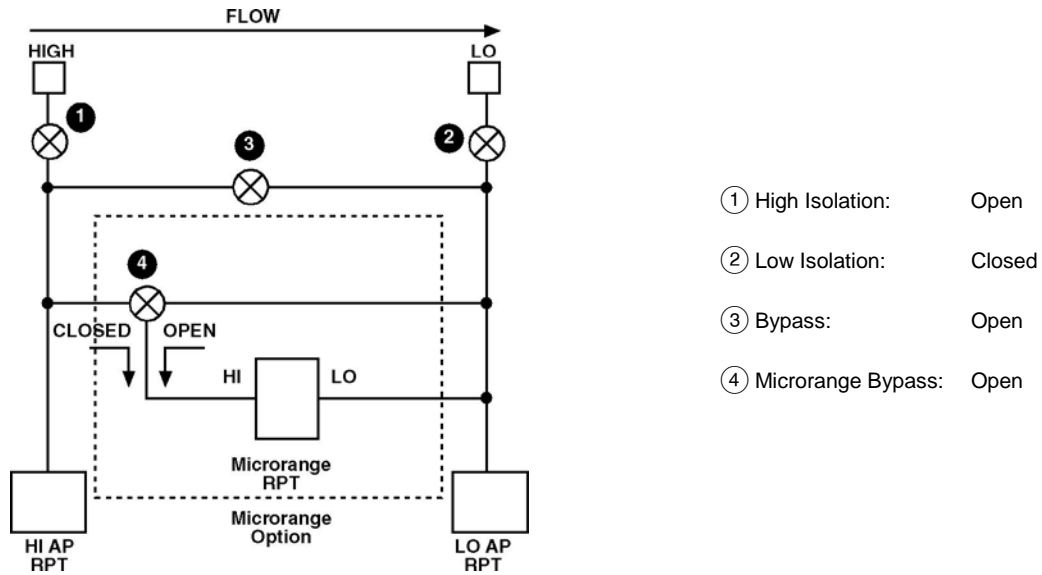

Figure 13. molbox RFM
Internal Pneumatic Schematic – molbloc-S OPERATION, BPR OFF

Ideally, the user is able to monitor the BPR with BPR ON while setting flows and pressures, and once the flow is established, uncertainties can be minimized by turning BPR OFF, gaining the benefit of using both RPTs upstream. As an alternate to operator switching between BPR ON and BPR OFF, molbox RFM has a BPR mode called AUTO that uses on-board logic to determine when to turn BPR ON and OFF. In BPR AUTO mode, the molbox uses cues based on flow and pressure changes, stability, and proximity to the Reynolds number-based BPR limits to determine when to switch between the BPR ON and BPR OFF valve states. AUTO is the default BPR mode and is considered the normal mode for manual molbloc-S/molbox RFM use.

For users who prefer to avoid automatic valving, there are two other BPR modes. BPR OFF mode keeps the molbox in the BPR OFF valve state at all times. BPR ON keeps the molbox in the BPR ON valve state at all times. BPR OFF mode should be used with caution, as it provides no monitoring of BPR to ensure that molbloc-S measurements are valid.

Note

When molbox RFM is used in BPR OFF mode, molbox cannot measure the molbloc-S downstream pressure and provides no monitoring or indication of the BPR. molbox RFM cannot warn the user when the flow through molbloc-S is not critical and flow measurements are not valid. For example, when the molbloc is at rest in BPR OFF mode, and atmospheric pressure is applied to both the upstream and downstream side of molbloc-S, the molbox will indicate a false flow rate approximately equal to the molbloc-S K_F value times the value of atmospheric pressure in kPa. If BPR OFF mode is used, the user must make sure that a sufficiently low BPR is maintained while making molbloc-S flow measurements (see Section 3.1.2). The [TARE], <5BPR> function can be used for quick BPR checks during BPR OFF (see Section 3.4.4.5).

○ OPERATION

To access the BPR mode menu, press [SPECIAL], <9BPR>.

The display is:

```
BPR mode:
1BPRoff 2BPRon 3Auto
```

Making a BPR mode selection, activates the selected BPR mode and returns to the previous RUN screen. [ESCAPE] returns to the previous RUN screen without changing the BPR mode.

Selecting <1BPRoff> causes, the molbox RFM internal valves to immediately switch to the BPR OFF valve state (see Figure 12), and remain there until the user changes the BPR mode or activates a function which causes a valve change (such as the [TARE], <5BPR> function, see Section 3.4.4.5). In BPR OFF mode, the flow is calculated from the average of the two RPT pressure readings and the RPT pressures displayed in the P&T pressure screen are adjusted using the dynamic tare feature, so both pressures are displayed equal to the average value (see Section 3.1.2 and 3.4.5)

Selecting <2BPRon> causes, the molbox RFM internal valves to immediately switch to the BPR ON valve state (see Figure 11), and remain there until the user changes the BPR mode or activates a function which causes a valve change. In BPR ON mode, flow is calculated from the upstream RPT measurement only. In BPR ON mode, there is no tare applied to the RPT readings at any time.

Selecting <3Auto> does not necessarily immediately change the BPR valve state. Depending on the current BPR mode, BPR mode changes occur as follows:

In Auto mode, in the BPR ON valve state:

molbox RFM monitors the BPR value directly. If the BPR is safely below the BPR limit (calculated from empirical testing of molbloc-S choking ratios, see Section 3.1.2), then, once the flow is stable within 0.5 % of reading for 3 seconds, molbox RFM switches to BPR OFF valve state and begins live averaging of the two RPT pressure values.

In Auto mode, in the BPR OFF valve state:

molbox RFM cannot monitor BPR, but based on the proximity of the most recently measured BPR to the calculated BPR limit, if the current flow value changes enough that it is likely that the BPR is approaching the limit, molbox RFM switches to BPR ON valve state to check BPR directly. It is highly unlikely that valve switching will occur during critical flow measurements because, typically, high precision flow measurements are not made when flow is changing.

In Auto mode, when the valves are in BPR OFF state, flow is calculated from the average of the two RPT pressure readings as in BPR OFF mode. When the molbox RFM valves switch to the BPR ON valve state in Auto mode, the tare can no longer be dynamically calculated because the two RPTs are not measuring the same pressure. The most recent tare that was automatically calculated during the BPR OFF valve state is used to correct the pressures used and displayed in Auto mode until the valves return to the BPR OFF state again. This assures that flow measurements remain as consistent as possible during Auto mode valve switching and that the tare value that is most likely to be correct is used at all times.

Note

It is possible to change the BPR mode by remote communication with molbox RFM and also to disable molbox RFM valve control and switching while in any BPR mode (see Section 4.3.4.2).

Notes

4. Remote Operation

4.1 Overview

Most of the molbox RFM's front panel functions can also be executed by commands from a remote computer. The host computer can communicate with the molbox RFM using the molbox RFM COM1 RS232 port or the IEEE-488 port. The command syntax is the same for either port except when using the IEEE STD. 488.2 Common Commands.

4.2 Interfacing

Sending a command to the molbox RFM will place it into remote mode. The remote indicator in the lower right hand corner of the molbox RFM front panel will light when the molbox RFM is in remote mode. It will also flicker when a command is received. The menus usually accessed from the front panel are locked-out while in remote. The **[P&T]** key will still respond to allow the user to change the data being viewed while the molbox RFM is in remote mode. Pressing the **[ESCAPE]** key will return the molbox RFM to local operation unless the "REMOTE" command was sent to the unit, which locks out keypad operation until the "LOCAL" command is sent.

Most remote commands will return a reply within 500 ms. You **must** wait for this reply before issuing another command to the molbox. This ensures that the molbox RFM has completed the command. An exception to this is the use of any of the IEEE STD. 488.2 Common Commands (see Section 4.3.4.1) via the IEEE-488 interface (common commands all start with an asterisk, "*"). The common commands only generate a reply if using the COM1 port or if the query form of the common command is used (command followed by a "?").

The following commands take more than 500 ms to reply:

ALLR, DP, FR, PR, RATE, SR, TARE	Up to 2 seconds to allow a new measurement.
GAS	Up to 5 seconds to complete a change.
TARESET, DEVICE=EXT, RESET	Up to 10 seconds to complete.

Note

LabVIEW drivers are available for the molbox RFM. These drivers allow users of the National Instruments' LabVIEW environment to create systems that include one or more molbox RFMs using LabVIEW virtual instruments instead of using the remote commands directly. The molbox RFM LabVIEW drivers are an abstraction of the remote commands into a consistent set of common and specific instrument functions. The drivers can be obtained at NO charge from the Fluke Calibration worldwide web site, www.flukecal.com.

4.2.1 RS232 Interface

To establish RS232 communications a standard "pin to pin" DB-9F to DB-9M RS232 cable must be used to connect the host COM port to molbox RFM COM1. The interface settings of both ports must be the same.

Note

molbox RFM supports an independent RS232 self-test to verify that the molbox RFM RS232 ports are operating correctly and the interface cable being used is valid. Use this self-test to troubleshoot if you are having difficulty establishing communications with molbox RFM COM1 (see Section 3.6.6.3).

4.2.1.1 COM1

The molbox RFM COM1 RS232 interface is located on the rear panel. It is a 9-pin female DB-9F connector configured as a DCE device. Data is transmitted out of molbox RFM using pin 2, and is received on pin 3. This allows a standard pin-to-pin DB-9M to DB-9F RS232 cable to be used to connect to a DTE host. Handshaking is NOT required or supported.

COM1 RS232 commands must be terminated with at least a single carriage return character, while line feed characters are ignored. All RS232 responses from the molbox RFM are terminated with a carriage return character and a line feed character.

Table 37. COM1 DB-9F Pin Designation

PIN #	FUNCTION	DESCRIPTION
2	TxD	This pin transmits serial data from the molbox RFM to the host.
3	RxD	This pin accepts serial data from the host computer.
5	Grn	This pin is the common return for the TxD and RxD signals.

IBM PC/XT DB-9F CONNECTIONS		IBM PC/XT DB-9M TO MOLBOX RFM DB9F CONNECTION	
DB-25M	DB-9F	DB-9M	DB-9F
2	3	3	3
3	2	2	2
7	5	5	5

4.2.1.2 COM2

The molbox RFM COM2 RS232 interface is located on the rear panel. It is a 9-pin male DB-9M connector configured as a DTE device. Data is transmitted out of the molbox RFM using pin 3 and is received on pin 2. This allows a standard pin-to-pin DB-9F to DB-9M RS232 cable to be used to connect to a DCE slave. Handshaking is NOT required or supported.

COM2 can be used to allow the host computer to communicate with another device (e.g., another molbox or multimeter) through the molbox RFM. This allows the user to use one host COM port or IEEE-488 port to communicate with the molbox RFM and an additional RS232 device. Refer to the “#” remote command for details (see Section 4.3.4.2).

Table 38. COM2 DB-9M Pin Designation

PIN #	FUNCTION	DESCRIPTION
2	RxD	This pin accepts serial data from another molbox RFM or another device.
3	TxD	This pin transmits serial data from the molbox RFM to another molbox RFM or another device.
4	DTR	Data Terminal Ready. Held at +5 Volts.
5	Gnd	This pin is the common return for the TxD and RxD signals.

IBM PC/XT DB-25F TO DB-9M CONNECTIONS		IBM PC/XT DB-9F TO MOLBOX RFM DB9M CONNECTION	
DB-25F	DB-9M	DB-9F	DB-9M
2	3	3	3
3	2	2	2
7	5	5	5

4.2.2 IEEE-488 (GPIB)

The molbox RFM IEEE-488 interface is located on the rear panel. The physical and electrical interface conforms to IEEE Std 488.1-1987 Subset E2 and IEEE Std. 488.2-1992. You should NOT attempt to communicate with the IEEE-488 interface while using the COM1 interface. The IEEE-488 receive buffer is 250 bytes deep. The molbox RFM will hold OFF release of the NRFD handshake line until it can service and empty the receive buffer. This keeps the buffer from overflowing.

IEEE-488 commands must be terminated with a single line feed character along with the assertion of the EOI line. All IEEE-488 responses from the molbox RFM are terminated with a line feed character along with the assertion of the EOI line. Replies are held in a buffer until the host computer gets them, so it is possible to have old replies in this buffer, while you are expecting new replies from a just issued command.

4.3 Commands

4.3.1 Command Syntax

All molbox RFM commands are ASCII strings. The user **must** wait for the molbox RFM to reply before sending another command. An exception to this is the use of any of the IEEE STD. 488.2 Common Commands via the IEEE-488 interface (these common commands are shown first, and always start with an asterisk, "*"). The common commands only generate a reply if using the COM1 port or the query form of the common command is used (command followed by a "?").

4.3.2 COMMAND summary

Table 39. Command Summary

SYNTAX	PURPOSE
*CLS	Clears the status registers and all queues.
*ESE(?)	Read or set the Event Status Enable register.
*ESR?	Read the Event Status Register.
*IDN?	Identify the product and software version.
*OPC(?)	Read or set the Operation Complete register (not applicable to the RFM).
*OPT?	Read the molbox RFM options installed.
*RST	Reset user settings to factory defaults.
*SRE(?)	Read or set the Service Request Register.
*STB?	Read the Status Byte.
*TST?	Read the system self-test results.
#	Send a command string out of the molbox RFM COM2 port.
ABORT	Stop an active averaging, tare, leak check or purge cycle.
AIRW(=)	Read or set the humidity ratio of the gas, AIR.
ALLR	Read the next measurement of molbloc flow, the RFM up and downstream RPT pressure values, the molbloc temperature, and the optional microrange RPT pressure.
BEEPER(=)	To actuate the internal beeper for half of a second.
BPR(=)	Read or set the back pressure ratio mode when using molbloc-S.
COMn(=)	Read or set the configuration of the COM1 or COM2 port.
DATE(=)	Read or set the internal time and date.
DEVICE=EXT	Loads information on molbloc connected to molbox RFM into molbox RFM.
DP	Read the differential pressure value being used to calculate flow.
ERR	Read the last error message.
FA=	Start a single flow averaging cycle.
FCOEF	Read the coefficient to convert kg/s to the current flow units.
FR	Read the next flow measurement.
FRA	Read the results of a completed flow averaging cycle.
FUNIT(=)	Read or set the flow display unit.
GAS(=)	Read or set the gas type being used.
GASCAL(=)	Read or set the active molbloc calibration to use.
GASCALS	List all calibrations available in the active molbloc.
ID (=)	Read or set the molbox RFM ID.
KFACT(=)	Read or set the "K" factor.
LEAKCK(=)	Start a molbox RFM or system leak check cycle or check if a cycle is complete.
LOCAL	Enable the front panel controls if in remote and go to local.
MEM	Read the memory test status.
MICRORNG(=)	Read or set the optional microrange operation mode.
MOLBLOC	Read the active molbloc header data. Does not load molbloc information.
OHMS	Read the resistance measurement of the molbloc's PRTs.
PCAL	Read or set the user RPT calibrations.
PCALDATE(=)	Read or set the user RPT calibration dates.
PCOEF	Read the coefficient to convert Pascal to the current pressure units.

Table 39. Command Summary (Continued)

SYNTAX	PURPOSE
PR	Read the next molbloc average pressure.
PRDP	Read the last measured microrange RPT pressure measurement (<i>tare</i> corrected).
PRHI	Read the last measured upstream pressure (<i>tare</i> corrected).
PRLO	Read the last measured downstream pressure (<i>tare</i> corrected).
PURGE(=)	Read the progress of or start the purge cycle.
PUNIT(=)	Read or set the pressure display unit.
RANGE	Read the range of the active molbloc.
RATE	Read the next available rate of change of flow.
RE	Read the current Reynolds number.
READYCK(=)	Read or set a flag that is cleared by a <i>Not Ready</i> condition.
REMOTE	Enable remote local lockout operation.
RES(=)	Read or set the flow resolution displayed on the front panel.
RESET	Reset the molbox RFM settings to the default operating parameters.
SN	Read the serial number of the molbox RFM.
SR	Read the next available ready status.
SS(=)	Read or set the stability required for a <i>Ready</i> <*> condition (flow unit/s).
STDRES(=)	Read or set the molbox RFM standard resistor values.
TARE	Read the current <i>tare</i> conditions and the current <i>tare</i> .
TARESETUP(=)	Prepares the unit to <i>tare</i> .
TARESET(=)	<i>Tare</i> the upstream and downstream RPTs (and microrange RPT, if present) or set <i>tare</i> to a given value.
TCAL (=)	Read or set the molbloc temperature calibration (channel dependent).
TEMP	Read the current molbloc temperature in the current units.
TIME(=)	Read or set the internal clock time.
TOTAL(=)	Read the progress of or start a new totalize cycle.
TUNIT(=)	Read or set the molbloc temperature unit.
UDU(=)	Read or set the user definable pressure unit.
USERCAL(=)	Read or set the user flow measurement adjustment.
UL(=)	Read or set the pressure upper limit for the internal RPTs.
UTEMP(=)	Read or set the temperature reference used for the user flow units.
VER	Read the molbox RFM version.
VLM(=)	Read or set the volume units pressure & temperature conditions.
ZOFFSET:HI	Read or set the AutoZ pressure offset, (Poffset), for the high RPT .
ZOFFSET:LO	Read or set the AutoZ pressure offset, (Poffset), for the low RPT .

4.3.3 Error Messages

The molbox RFM will always reply to a command. If the command is incorrect or contains invalid data, an error number will be returned in the form "ERR# *n*" where *n* is an integer number that represents a specific error. This allows for easy error trapping by the host computer. **Table 40** is a list of the possible error numbers and the error description for each.

Table 40. Error Messages

REPLY	DESCRIPTION
ERROR	"The molbox RFM is in high security level and cannot accept remote commands"
ERR# 0	"OK"
ERR# 1	"molbloc flow is too great"
ERR# 2	"Text argument is too long"
ERR# 3	"User defined coefficient cannot be 0"
ERR# 4	"External device not detected"
ERR# 5	"External device improperly configured"
ERR# 6	"Numeric argument missing or out of range"
ERR# 7	"Missing or improper command argument(s)"
ERR# 8	"External device timeout error"
ERR# 9	"Unknown command"
ERR# 11	"Command missing argument"
ERR# 12	"System overpressured"
ERR# 13	"Text detected in numeric field"
ERR# 14	"User unit not defined"
ERR# 15	"Averaging cycle not started"
ERR# 17	"Selected gas not available"
ERR# 18	"Command not yet available"
ERR# 19	"Not supported"
ERR# 20	"Not supported"
ERR# 21	"User device not defined"
ERR# 22	"Pressure is not stable"
ERR# 23	"Option not available or installed"
ERR# 24	"molbloc not detected"
ERR# 25	"Transducer out of calibration"
ERR# 26	"COM port failed to initialize"
ERR# 27	"Internal device #1, 2 or 3 timeout error"
ERR# 29	"Busy averaging"
ERR# 30	"Fatal mass flow calculation error"
ERR# 31	"molbloc EEPROM is full"
ERR# 32	"molbloc gas not found"
ERR# 34	"molbloc is write protected"
ERR# 35	"molbloc write error"
ERR# 37	"Gas table is full"

ERR# 38	"Selected range not available"
ERR# 39	"molbloc verify error"
ERR# 40	"molbloc read error"
ERR# 41	"molbloc invalid"
ERR# 42	"PRT measurement error"
ERR# 44	"Entry already exists"
ERR# 45	"Argument not allowed"
ERR# 46	"The leak is too large"
ERR# 47	"Temperature change was too great"
ERR# 48	"Offset was excessive. Check tare"
ERR# 49	"Possible upstream leak"
ERR# 50	"Possible downstream leak"

4.3.4 Command Descriptions

Each command description gives the full syntax showing usage. Ranges of parameters or parameter types are indicated. There are 2 types of commands. The Common and Status Commands support IEEE Std. 488.2, while the molbloc RFM commands access all other functions.

4.3.4.1 IEEE Std. 488.2 Common and Status Commands

The molbox RFM supports a set of commands that are common to all instruments conforming to IEEE Std. 488.2 protocol. Though defined by the IEEE-488.2 standard, they also apply to molbox RFM RS232 (COM1) communications. These commands make it easy to perform basic functions for any device that supports them. These command also cover the status reporting commands. Refer to Section 4.4 for details on the status registers mentioned in these commands. Query forms of these commands must be followed by a question mark and IEEE-488.2 Common Commands always start with an asterisk ("*"). Unlike the other molbox RFM commands, they must have a space instead of an equals sign ("=") between the command and any arguments. Also unlike the other molbox RFM commands, if you are using the IEEE-488 port, the query form (command is immediately followed by a "?") must be used to get a reply. If using the COM1 port and the command is not a query, "OK" will be replied.

*CLS	
Purpose	Clear all of the status and event structures.
Syntax	"*CLS"
Remarks	This program message clears the following evens and status registers: Standard Byte Register (STB) Standard Event Status Register (ESR) Error Queue Pending OPC operations
Example	Command: "*CLS" Reply: "OK" (using COM1, no reply if IEEE-488 port)

*ESE(?)	
Purpose	Read or set the standard event status enable register.
Syntax	"*ESE <i>n</i> " "*ESE?"
Parameters	<i>n</i> : '0 to 255'. This is the decimal representation of the bit(s) to enable. To enable the PON and QYE bits, the argument would be 128 + 4 = 132.
Query Reply	<i>n</i> (0 to 255)
Remarks	The standard event status enable register determines which bits in the standard event status register are enabled and included in the status byte register (ESB bit), and can assert the SRQ line. The reply is in decimal numeric form.
Example	Command: "*ESE 132" Reply: "OK" (using COM1, no reply if IEEE-488 port) Command: "*ESE?" Reply: "132"

*ESR?	
Purpose	Read the standard event register.
Syntax	"*ESR?"
Query Reply	<i>n</i> (0 to 255)
Remark	The standard event register contents are cleared after reading. The reply is in decimal numeric form.
Example	Command: "*ESR?" Reply: "4"

*IDN?	
Purpose	Identify the molbox RFM version, range, and serial number.
Syntax	"*IDN?"
Remarks	The identification reply is made up of the manufacturer, the model, the serial number and the software version. Each is separated by a comma.
Query Reply	The version string
Example	Command: "*IDN?" Reply: "FLUKE, molbox RFM, 1001, Ver1.20-ngml"

*OPC(?)	
Purpose	Sets the operation complete bit when all operations have completed.
Syntax	"*OPC" "*OPC?"
Remarks	This command enables the molbox RFM to set the OPC bit in the standard event status register when it has completed all pending functions. The query replies with a "1" when all functions are complete. Since the molbox RFM does not support overlapping commands, this command has no practical use.
Query Reply	"0" or "1"
Example	Command: "*OPC" Reply: "OK" (using COM1, no reply if IEEE-488 port) Command: "*OPC?" Reply: "1"

*OPT?	
Purpose	Reads the list of installed molbloc RFM options.
Syntax	"*OPT?"
Remarks	This query returns any registered option(s) installed in the molbox RFM. Each option is separated by a comma.
Query Reply	A comma delimited text field of the installed options
Example	Command: "*OPT?" Reply: "NONE" (no options installed) Reply: "microrange" (microrange option installed)

*RST	
Purpose	Resets the molbox RFM settings to factory settings.
Syntax	"*RST"
Remarks	This command sets the molbox RFM settings to factory settings which is equivalent to pressing [SPECIAL] on the front panel and selecting <5Reset> , 1sets . This does not affect the communications settings.
Example	Command: "*RST" Reply: "OK" (using COM1, no reply if IEEE-488 port)

*SRE(?)	
Purpose	Read or set the service request enable register.
Syntax	"*SRE <i>n</i> "
	"*SRE?"
Parameters	<i>n</i> : '0 to 255'. This is the decimal representation of the bit(s) to enable. To allow the MAV and ESB bits to assert the SRQ line, the argument would be 32 + 16 = 48. Bit 6 (64) is reserved and cannot be set.
Remarks	The service request enable register determines which bits of the status byte can set the MSS bit of the status byte and request service by asserting the SRQ line of the IEEE-488 interface.
Query Reply	<i>n</i> (0 to 255)
Example	Command: "*SRE 48" Reply: "OK" using COM1, no reply if IEEE-488 port) Command: "*SRE?" Reply: "48"

*STB?	
Purpose	Read the status byte register.
Syntax	"*STB?"
Remarks	The status byte register reflects the general status of the molbox RFM. The 'MSS' bit state is represented by bit 6.
Query Reply	<i>n</i> (0 to 255)
Example	Command: "*STB?" Reply: "4"

*TST?	
Purpose	Read the power on self test status.
Syntax	"*TST?"
Remarks	The molbox RFM system memory stores the user settings (units, mode, resolution) and retains them when the unit is shutoff. On power up, this memory is checked. If this memory is corrupted, all user settings are reset to default (as if the "*RST" program message was executed), and the *TST query returns a '1'. If the molbox RFM passed the test on power up OR if the *TST query was used at least once since the unit was powered up the reply is '0'.
Query Reply	"0" or "1"
Example	Command: "*TST?" Reply: "1"

4.3.4.2 molbox RFM commands

#	
Purpose	To allow the Host computer to communicate with a device connected to the molbox RFM COM2 port.
Syntax	"#XX"
Arguments	xx: The string to send out of the COM2 port. It must be less than 40 characters long.
Remarks	<p>The molbox RFM COM2 port can be used to communicate to another RS232 device (e.g., another molbox RFM or a multimeter). This allows the user to use one COM port or IEEE-488 port on the host computer to communicate with the molbox RFM and another device. A carriage return and a line feed (<CR><LF>) are added to the string.</p> <p>After this command is issued, the molbox RFM will reply back the first string received by the molbox RFM COM2 port that is terminated with a carriage return. Line feeds are discarded. This will discontinue when any command is sent to the molbox RFM.</p> <p>There is no other reply from this command. Prior to using this command, you must ensure that the molbox RFM COM2 port is correctly set up to communicate with the device. Refer to the "COM2=" command.</p>
Example	Command: "#VER" Reply: "DH INSTRUMENTS, INC molbox RFM Ver1.10"
ABORT	
Purpose	To stop an active averaging, <i>tare</i> , purge or leak check cycle, or reset the GASCALS list of available gas calibrations.
Syntax	"ABORT"
Remarks	This command should be used to ensure that molbox RFM is in a known state. The <i>tare</i> , purge, and leak check cycles put the RFM into a condition where it is not usable for normal flow measurement, so the "ABORT" command should be used before general operation of the unit begins if the previous state of the unit is not known. The "ABORT" command also clears out any previous leak or <i>tare</i> cycle errors. Also used to reset the listing of gas calibrations to the first calibration in the list prior to using the GASCALS command.
Example	Command: "ABORT" Reply: "ABORT"
See Also	"FA", "TARESETUP", "LEAKCK", "PURGE", "GASCALS"

AIRW(=)	
Purpose	Read or set the humidity ratio for the gas, AIR.
Syntax	"AIRW= <i>HumidityRatio</i> " "AIRW"
Default	"AIRW=0.00 00"
Arguments	<i>HumidityRatio</i> : The humidity ratio (0-0.1)
Remarks	The humidity ratio is only used if the gas is set to specify AIR. For all other gas types, the ratio is ignored.
Example	Command: "AIRW=.01" Reply: "0.0100"
Errors	ERR# 6: The humidity ratio is invalid.
See Also	3.2.2, 3.4.2.2 "GAS"

ALLR	
Purpose	Read the next measurement of molbloc flow, the RFM upstream and downstream RPT pressure values, the molbloc temperature, and the optional microrange RPT pressure.
Syntax	"ALLR"
Remarks	The next available measurements are replied. This can take up to 1 second, since the molbox RFM waits for the next flow measurement before replying. The reply starts with the flow ready information. Then the flow value is given in the current flow units. Commas are then used to separate the other measurements in this order: "RDY flow, avgpres, uppres, dnpres, temp, micropres" "RDY" is the flow ready field. The ready status is covered in the "SR" command. "flow" is the current measured flow and flow units. "avgpres" is the average of the upstream and downstream RPTs and units. "uppres" is the upstream RPT pressure measurement and units. "dnpres" is the downstream RPT pressure measurement and units. "temp" is the molbloc temperature and units. "micropres" is the optional microrange RPT pressure measurement and units.
Example	Command: "ALLR" Reply: "R 1.2 sccm,97.697 kPa a,97.685 kPa a,97.708 kPa a,17.97C,0.0261 kPa"
Errors	ERR# 27: One of the RPTs (transducer) is not functioning.
See Also	"SR", "READYCK", "DP", "HIP", "LOP", "FR"

BEEPER(=)	
Purpose	To actuate the internal beeper for half of a second.
Syntax	"BEEPER" "BEEPER=freq"
Arguments	freq: The desired frequency from 250 to 10 000 Hz. If a frequency is not indicated, the current default frequency will be used.
Remarks	The internal beeper is also used to indicate overpressure conditions, which will over-ride this command.
Example	Command: "BEEPER=5000" Reply: "5000"
Errors	ERR# 7: The frequency is invalid.

BPR(=)	
Purpose	Read or set the back pressure ratio (BPR) mode. This is only available when using a molbloc-S.
Command:	"BPR = <i>mode</i> " "BPR= <i>mode, suspend</i> "
Query:	"BPR"
Defaults	"BPR=2,0"
Arguments	<i>mode</i> : '0' BPR is kept "OFF" '1' BPR is kept "ON" '2' BPR is in "auto" mode. <i>suspend</i> : '0' BPR normal operation '1' BPR function is suspended, left in the current condition until set back to normal operation.
Remarks	The BPR mode determines the operation when the back pressure ratio is measured when using molbloc-S to measure flow. The optional " <i>suspend</i> " argument can be used to leave the BPR valve state in it's current condition, allowing manual manipulation of the molbox valves without the BPR function intervening. If the " <i>suspend</i> " argument is not given, it is presumed to be '0' for normal BPR operation.
Example	Sent: "BPR=2" Reply: "2, 0" Sent: "BPR=1,1" Reply: "1, 1"
Errors	ERR# 6: One of the arguments is out of range.
See Also	3.6.9

COMn(=)	
Purpose	To set or read the configuration of the COM1 or COM2 ports.
Syntax	"COMn=baud,parity,data,stop" "COMn"
Arguments	n: The COM port: '1' or '2'. baud: The baud rate. This may be '300', '600', '1200', '2400', '4800', or '9600'. parity: The data parity. This may be 'O' for odd, 'E' for even or 'N' for none. data: The data word length. This may be '7' or '8'. stop: The number of stop bits. This may be '1' or '2'.
Defaults	"COM1=2400,E,7,1" "COM2=2400,E,7,1"
Remarks	The COM1 port is used to communicate to the molbox RFM. When the COM1 port configuration of the molbox RFM is changed, the command reply will be sent at the old COM1 settings, but all subsequent communications will be accomplished at the new COM1 settings. The COM2 port is used to allow commands to be passed through the molbox RFM to a device connected to the COM2 port (refer to the '#' command).
Example	Command: "COM1=9600,N,8,1" Reply: "9600,N,8,1"
Error	ERR# 7: Missing or improper command argument(s).
See Also	3.4.6

DATE(=)	
Purpose	Read or set the internal clock date.
Syntax	"DATE" "DATE=yyyymmdd"
Arguments	yyy: The year from 1980 to 2079. mm: The month from 1 to 12. dd: The day from 1 to the last valid day of the given month.
Example	Command: "DATE=19981005" Reply: "19981005"
Errors	ERR# 7: The time date is invalid.

DEVICE=EXT	
Purpose	To load the molbloc data into the molbox RFM.
Syntax	"DEVICE=EXT"
Remarks	The molbloc calibration data is stored in the external molbloc. This data is normally loaded on power up, but can be reloaded using this command if the molbloc has been changed since power up. Loading the data normally takes less than a second, but can take up to 10 seconds if the molbox has problems communicating with the molbloc.
Example	Command: "DEVICE=EXT" Reply: "EXT"
Errors	ERR# 24: A molbloc is not connected to the molbox RFM. ERR# 35: The molbloc experienced a communications timeout. ERR# 40: timeout. ERR# 41: The molbloc experienced a read checksum failure. The molbloc data header is corrupted.
See Also	3.2.8 and 3.3.4

DP	
Purpose	Read the differential pressure value used by molbox RFM to calculate flow.
Syntax	"DP"
Remarks	The molbox RFM has upstream and downstream absolute RPTs and may have an optional microrange differential RPT. The pressure returned by this command is the differential pressure value that is being used by molbox RFM to calculate flow. Depending on the microrange setting, this can be the <i>tare</i> adjusted difference between the 2 absolute RPTs, the <i>tare</i> adjusted microrange RPT, or a combination of the two. The first 3 characters of the reply from molbox RFM make up the <i>Ready/Not Ready</i> condition (see the "SR" command). The differential pressure string follows it.
Example	Command: "DP" Reply: "R 0.07 kPa"
See Also	3.2.5, 3.1.2.6, 3.1.2.4, "SR", "MICRORNG"

ERR	
Purpose	Read the last error message.
Syntax	"ERR"
Remarks	The "ERR" command provides more details about an error that has occurred. If the user receives an "ERR# nn" reply, the "ERR" command returns a brief description about the last error number that was replied.
Example	Command: "ERR" Reply: "Missing or improper command argument(s)"
See Also	4.3.3

FA=	
Purpose	Start a single flow averaging cycle.
Syntax	"FA=period"
Arguments	period: The averaging period in seconds (from 4 to 999 seconds).
Remarks	This command is used to start an averaging period that results in the average molbloc flow and standard deviation of the molbloc flow over this period. After sending this command you can monitor the averaging cycle by using the "FR" or "SR" command to determine when the averaging cycle is complete. Once the cycle is done, you must use the "FRA" command to collect the results.
Example	Command: "FA=20" Reply: "20 s"
Errors	ERR# 6: The period argument is not within the specified limits.
See Also	3.2.6.2, "FR", "SR", "FRA", "ABORT"

FCOEF	
Purpose	Read the coefficient that converts kg/s to the current flow units.
Syntax	"FCOEF"
Remarks	The flow coefficient is a value that is used to convert kg/s to the current flow units. It is dependent on the current flow unit and the gas selected. To use this coefficient, multiply it by kg/s to get flow in the current flow units.
Example	Command: "FCOEF" Reply: "4.798073e+004"
See Also	3.2.2. and 7.1.3

FR	
Purpose	Read the next measurement of flow through the molbloc as calculated by the molbox RFM.
Syntax	"FR"
Remarks	The next available flow value is read in the current flow units. This can take up to 1 second, since the molbox RFM waits for the next flow measurement before replying. The reply also contains ready information. The first 3 characters are reserved for the <i>ReadyNot Ready</i> status. The <i>Ready/Not Ready</i> status is covered in the "SR" command. The flow measurement number starts at the fifth character, and is followed by the flow units.
Example	Command: "FR" Reply: "R 0.00001 sccm"
Errors	ERR# 27: One of the RPTs (transducer) is not functioning.
See Also	3.1.2.4, "SR", "READYCK"

FRA	
Purpose	Read the results of a completed flow averaging cycle.
Syntax	"FRA"
Remarks	<p>This command is used to check on the status of or collect the results of an averaging cycle that was started earlier using the "FA=" command. During the averaging cycle, this command will reply "BUSY" until the averaging cycle is complete. Then the reply will be the result of the averaging cycle. If the cycle is aborted before it is complete (see "FA="), then the data will be lost.</p> <p>The data that is returned from the command consists of multiple numeric fields delimited by commas. The flow numbers are in the current flow unit of measure. The actual data fields returned are as follows:</p> <p>An "H" will appear as the first character of the reply string. An "S" will appear as the second character of the string if the flow stability stayed within the stability setting during the sequence. From the fourth position on, the numeric data fields are:</p> <p>Average flow over the averaging period.</p> <p>Standard deviation of flow over the averaging period.</p> <p>The minimum flow reached during the period.</p> <p>The maximum flow reached during the period.</p> <p>"NA" always.</p> <p>"NA" always.</p>
Example	<p>Command: "FRA"</p> <p>Reply: "HS 0.00002 sccm,0.00000,0.00002,0.00002,NA,"</p> <p>Reply: NA"</p> <p>"BUSY" if still averaging.</p>
Errors	ERR# 15: The "FR" command was not sent previous to this command.
See Also	3.2.6.2, "FR", "SR", "FA"

FUNIT(=)	
Purpose	Read or set the unit of measurement for the flow through the molbloc as calculated by the molbox RFM.
Syntax	"FUNIT= <i>unit</i> " "FUNIT"
Arguments	"FUNIT=sccm"
Defaults	unit: The flow unit used to display the measured flow.
Remarks	The flow unit displayed can be changed using this command. The flow unit must be supported by the molbox RFM. The flow unit protocol is the same as the front panel flow unit definitions.
Example	<p>Command: "FUNIT=SLM"</p> <p>Reply: "SLM"</p>
Errors	ERR# 7: The flow unit is invalid or not supported by the molbox RFM.
See Also	3.2.6.5, "UTEMP", "VLM"

GAS(=)	
Purpose	Read or set the gas type being flowed through the molbloc.
Syntax	"GAS= <i>gas</i> " "GAS"
Arguments	gas: The gas to use.
Remarks	The gas type being flowed through the molbloc is specified using this command. The gas must be supported by the molbox RFM. The gas type protocol is the same as the front panel gas definitions. A valid molbloc must be connected to the molbox RFM before changing the gas type.
Example	Command: "GAS=AR" Reply: "Ar"
Errors	ERR# 7: The gas is invalid for the molbox RFM. ERR# 24: A molbloc is not connected to the molbox RFM. ERR# 32: This gas is not supported by the molbox RFM. ERR# 35: The molbloc experienced a communications time out. ERR# 39: The molbloc experienced a data verification failure. ERR# 40: The molbloc experienced a read checksum failure. ERR# 41: The molbloc data header is corrupted.
See Also	3.2.2

GASCAL (=)	
Purpose	Read or set the active molbloc calibration to use.
Query	"GASCAL= <i>gas</i> (<i>, calname</i>)" "GASCAL"
Default	"GASCAL=N2"
Arguments	Gas:
Calname	Calibration Calibration name (optional. Same as <i>gas</i> Gas assumed if blank or ignored if molbloc does not have named calibrations)
Remarks	A molbloc can contain multiple calibrations, possibly for each gas. The calibration should be selected before use. This command selects the desired calibration by referring to the calibration gas, and optionally by the unique name given to the calibration for that gas if the molbloc supports multiple calibrations. The "GASCALS" command should be used prior to the "GASCAL" command to determine what calibrations are available in the molbloc..
Example	Sent: "GASCAL=HE, LOP" Query reply: "HE, LOP" Sent: "GASCAL=HE" (<i>calname</i> not given so "HE" is assumed) Query reply: "HE, HE"
Errors	ERR# 2: The gas or calibration name given is too long. ERR# 24: A molbloc is not connected to the molbox. ERR# 32: The calibration was not found. ERR# 35: The molbloc experienced a communications time out. ERR# 40: The molbloc experienced a read checksum failure.
See Also	"GASCALS" command "GAS" command

GASCALS	
Purpose	List out the calibrations in an active mobloc..
Query	"GASCALS"
Remarks	<p>All of the calibrations in an active molbloc created with molbox version 6.00 or greater can be listed one at a time using the GASCALS command. You MUST first send the ABORT command to "reset" the listing of the calibrations, then send the "GASCALS" command to get each calibration until there are no more calibrations. Here are the 4 fields that are returned for each calibration found:</p> <p>Calibration gas: The name of the gas for this calibration. This is one of the know gas types supported by the molbox</p> <p>Calibration name: The unique name for this calibration. (Only present on molblobs with named calibrations)</p> <p>Calibration range: The range and range unit for this calibration. (Only present on molblobs with named calibrations)</p> <p>Attributes: Each calibration has several attributes. These attributes are reported as a sum of the possible attribute values (Only present on molblobs with named calibrations):</p> <p>'1' NOT a default calibration. Default calibrations are used when the "GAS=" command is used to specify which calibration to use using just the gas name. This attribute when set indicates that this is NOT a default calibration.</p> <p>'4' Calibration is a "premium" calibration.</p> <p>'8' Calibration is a "downstream" calibration.</p>
Example	<p>Sent: "GASCALS"</p> <p>Reply: "He, LOP ,1 slm, 0" Named default calibration "He, LOP ,1 slm, 4" Default premium calibration "He, LOP ,1 slm, 6" Default premium calibration. Other He calibration exist on this molbloc "He" molbloc does not supports named calibration</p>
Errors	ERR# 32: No more calibrations exist in the molbloc.
See Also	"ABORT" command "GAS" command "GASCAL" command

ID(=)	
Purpose	Read or set the user defined identification label.
Syntax	"ID=string" "ID"
Default	"ID=NONE" (no microrange option)
Arguments	string: An alphanumeric string up to 12 characters wide.
Remarks	The user defined ID label can be used to allow the user to "tag" the molbox RFM with a unique identifier. This ID is stored in non-volatile memory and cannot be erased by a power failure, system fault or reset.
Example	Command: "ID=RFM-001" Reply: "RFM-001"
See Also	3.4.5.4

KFACT(=)	
Purpose	Read or set the molbox RFM K factor.
Syntax	"KFACT= <i>kfactor</i> " "KFACT"
Arguments	kfactor: The new "K" factor.
Defaults	"FACT=1.0" (Disabled)
Remarks	The "K" factor is set to 1 for normal operation.
Example	Command: "KFACT" Reply: "1.000000"
See Also	3.2.1

LEAKCK(=)	
Purpose	Starts a molbox RFM or system leak check cycle or checks if a cycle is complete.
Syntax	"LEAKCK=type(,microrange)" "LEAKCK"
Arguments	<p>type: "BOX" starts a leak check cycle on the molbox RFM internal circuit. The molbox must be prepared for the leak check by setting pressures and venting ports before the leak check is executed.</p> <p>"SYS" starts a leak check cycle on the system connected to the molbox RFM. The system must be prepared for the leak check by setting pressures and operating valves before the leak check is executed.</p> <p>microrange: '0' If the 'type' specified is "BOX", then the microrange RPT will be bypassed (inactive) during the leak check cycle.</p> <p>'1' If the 'type' specified is "BOX", then the microrange RPT will NOT be bypassed (active) during the leak check cycle.</p>
Remarks	<p>This command is used to start and monitor the progress of the leak check. Both "BOX" and the "SYS" leak checks take 60 seconds to complete. At the end of the leak check, the molbox RFM is returned to its normal operating state. For the "BOX" leak check, the microrange RPT is normally bypassed (inactive) unless the optional second argument is given. For the "SYS" leak check, the microrange RPT is always bypassed.</p> <p>The "ABORT" command can be used to stop a leak check cycle, clear out any previous error messages, and return the molbox RFM to its normal operating state. While the leak check cycle is executing, a 'b' ("busy") will appear in the third character position of the "FR" and the "SR" command replies.</p> <p>If the leak check failed, an error will be replied to the "LEAKCK" query until the "ABORT" command is used to abort the leak check. When the leak check has completed without an error, the "LEAKCK" query will reply "OK".</p> <p>The "LEAKCK" command must be completed or aborted using the "ABORT" command before performing other operations.</p>
Example	<p>Command: "LEAKCK=BOX,1"</p> <p>Reply: "BOX" (starting new RFM leak check cycle including the microrange RPT)</p>
	<p>Command: "LEAKCK=SYS"</p> <p>Reply: "SYS" (starting new system leak check cycle)</p> <p>Command: "LEAKCK"</p> <p>Reply: "23 sec" A leak check cycle is currently running. This is the number of seconds remaining in the test.</p> <p>Reply: "OK" (The leak check cycle has completed.)</p>

Errors	ERR# 6: One of the arguments is not invalid. ERR# 15: A leak check cycle has not been started. ERR# 23: The microrange option is not installed in this RFM. ERR# 46: A large leak exists. ERR# 47: The temperature changed too much to test for a leak. ERR# 48: A leak exists. ERR# 49: The absolute RPT disagreement too great to test for a leak. ERR# 50: Possible upstream leak. ERR# 51: Possible downstream leak. Possible bypass leak.
See Also	3.2.4.3, "ABORT"

LOCAL	
Purpose	Enable the front panel controls if in remote and go to local mode.
Syntax	"LOCAL"
Remarks	In LOCAL mode, all front panel operations are available. The LOCAL command deactivates REMOTE mode.
Example	Command: "LOCAL" Reply: "LOCAL"
See Also	"REMOTE"

MEM	
Purpose	Read the memory test status.
Syntax	"MEM"
Remarks	On power up, a memory test is run to check the integrity of the internal data NVRAM. If the memory has been corrupted, "FATAL MEMORY FAULT" will be displayed on power up to alert the user, and the memory test status command will return a '0'. The command will return a '1' if the memory is OK.
Example	Command: "MEM" Reply: "0"

MICRORNG(=)	
Purpose	Read or set the optional microrange operation mode.
Syntax	"MICRORNG=mode" "MICRORNG"
Defaults	"MICRORNG=AUTO"
Arguments	mode: "OFF": AUTO and MANUAL MICRORANGE functions are turned OFF. "AUTO": AUTO MICRORANGE function is turned ON. "ON": MANUAL MICRORANGE function is turned ON.
Remarks	The AUTOMATIC and MANUAL MICRORANGE functions control the way that the microrange option is used in the molbox RFM. The command in it's query form can also be used to tell if the microrange option is installed in a molbox RFM.
Example	Command: "MICRORNG=AUTO" Reply: "AUTO" Command: "MICRORNG" Reply: "OFF" (AUTO and MANUAL functions are disabled) Reply: "AUTO" (AUTO function is enabled) Reply: "ON" (MANUAL function is enabled)
Errors	ERR# 7: The argument is invalid. ERR# 23: The microrange option is not installed in this molbox RFM.
See Also	3.1.2.6, 3.2.7, and 3.4.3

MOLBLOC	
Purpose	Read the active molbloc header data. This command does NOT load molbloc information.
Syntax	"MOLBLOC"
Remarks	The external molbloc header data includes the serial number, range, calibration date, and PRT calibration data. This data is stored in the molbloc, and is downloaded to the molbox RFM on power up. The data for the active molbloc is returned in a single, comma delimited string in the following order: Serial Number Range Designator Range Flow Units Gas Calibration Date (yyyymmdd) Total PRT Resistance (upstream + downstream) at 0 °C [Ω] PRT Slope [dimensionless] Upstream PRT Resistance at 0 °C [Ω] Downstream PRT Resistance at 0 °C [Ω]
Example	Command: "MOLBLOC" Reply: "100,1.00,sccm,N2,01/01/94,200.0050,0.7792,100.0010,100.0040"

Errors	ERR# 7: The gas is invalid with the molbox RFM. ERR# 24: A molbloc is not connected to the molbox RFM. ERR# 35: The molbloc experienced a communications timeout. ERR# 40: timeout. ERR# 41: The molbloc experienced a read checksum failure. The molbloc data header is corrupted.
See Also	3.2.8, "DEVICE=EXT"

OHMS	
Purpose	Read the resistance of the active molbloc's PRTs in ohms.
Syntax	"OHMS"
Remarks	The most recent molbloc upstream and downstream PRT resistance measurement is returned in ohms. An error will be returned if there is a problem reading the molbloc PRTs.
Example	Command: "OHMS" Reply: "107.075 Ohms, 107.079 Ohms"
Errors	ERR# 42: There is an error in the molbox RFM PRT measurement.
See Also	3.2.5, "TEMP", "STDRES"

PCAL(=)	
Purpose	Read or set the user RPT calibration adjustments (<i>PA</i> , <i>PM</i>).
Syntax	"PCAL=upadder, upmult, dnadder, dnmult, (mrradder, mrmult)" "PCAL"
Defaults	"PCAL=0, 1.00000, 0, 1.00000" (no microrange option) "PCAL=0, 1.00000, 0, 1.00000, 0.0, 1.00000" (microrange option)
Arguments	upadder: The upstream RPT calibration <i>adder</i> (<i>PA</i>) from – 10 000 to 10 000 Pa. upmult: The upstream RPT calibration <i>multiplier</i> (<i>PM</i>) from 0.9 to 1.1. dnadder: The downstream RPT calibration <i>adder</i> from –10 000 to 10 000 Pa. dnmult: The downstream RPT calibration <i>multiplier</i> from 0.9 to 1.1 mrradder: The optional microrange RPT calibration <i>adder</i> from -10 000 to 10 000 Pa. mrmult: The optional microrange RPT calibration <i>multiplier</i> from 0.9 to 1.1.
Remarks	The user defined pressure calibration for the upstream and downstream RPTs can be access with this single command. The <i>adder</i> is always in Pascal.
Example	Command: "PCAL=38, 1.0021, 14, .9942" (no microrange option) Reply: "38 Paa, 1.00210, 14 Paa, 0.99420" Command: "PCAL=38, 1.0021, 14, .9942, 6, 1.0001" (microrange option) Reply: "38 Paa, 1.00210, 14 Paa, 0.99420, 6.0 Paa, 1.0001"
Errors	ERR# 6: Invalid argument.
See Also	5.2

PCALDATE(=)	
Purpose	Read or set the user RPT calibration dates.
Syntax	"PCALDATE=yyyymmdd, yyyymmdd (,yyyymmdd)" "PCALDATE"
Defaults	"PCALDATE=19980101,19980101 (no microrange option)" "PCALDATE=19980101,1998010119980101" (microrange option)
Arguments	yyyy: The year from 1980 to 2079 mm: The month from 1 to 12 dd: The day from 1 to the last valid day of the given month
Remarks	The user defined pressure calibration dates for the upstream and downstream RPTs (and optional microrange RPT) can be access with this single command in this order.
Example	Command: "PCALDATE=19981005, 19981005" (no microrange option) Reply: "19981005, 19981005" Command: "PCALDATE=19981005,19981005,19981005" (microrange option) Reply: "19981005,19981005,19981005"
Errors	ERR# 7: One or more of the date(s) are invalid.
See Also	5.2, "PCAL(=)"

PCOEF	
Purpose	Read the coefficient to convert Pascal [Pa] to the current pressure units.
Syntax	"PR"
Remarks	The pressure coefficient (PCOEF) is a value that is used to convert Pascal units to the current pressure units. To use this coefficient, multiply it by pressure in Pascal to get pressure in the current units.
Example	Command: "PCOEF" Reply: "1.000000e-003"
See Also	7.1.1, "UNIT"

PR	
Purpose	Read the next molbloc average pressure.
Syntax	"PR"
Remarks	The next available average pressure value is read in the current pressure units. It is the average of the tare corrected upstream and the downstream transducers. The data string also contains flow ready information and the pressure units. The first 3 characters of the reply are reserved for the flow Ready/Not Ready status. The Ready/Not Ready status is covered in the "SR" command. The pressure measurement number starts at the fifth character, and is followed by the pressure unit of measure.
Example	Command: "PR" Reply: "R 247.598 kPaa"
See Also	3.1.2.4, "READYCK", "SR", "PRDP", "PRHI", "PRLO"

PRDP	
Purpose	Read the last molbloc microrange transducer pressure.
Syntax	"PR"
Remarks	The last measured pressure from the optional microrange differential pressure transducer is read in the current pressure unit of measure. It is <i>tare</i> corrected. Depending on the molbloc pressure, the microrange transducer may be bypassed. If it is bypassed (both RPT inputs connected together to the upstream pressure), then a '>' will appear in the reply to indicate that the measurement does not represent the differential pressure across the molbloc.
Example	Command: "PRDP" Reply: "10.5 kPa" (RPT is not bypassed - it is active) Reply: ">10.5 kPa" (RPT is bypassed - it is inactive)
Errors	ERR# 23: The microrange option is not installed.
See Also	3.1.2.6, "DP", "PR", "PRHI", "PRLO"

PRHI	
Purpose	Read the last measured upstream absolute pressure (<i>tare</i> corrected).
Syntax	"PRHI"
Remarks	The current upstream pressure value (corrected for <i>tare</i>) is returned in the current pressure unit of measure.
Example	Command: "PRHI" Reply: "247.56 kPaa"
See Also	"DP", "PRDP", "PR", "PRLO"

PRLO	
Purpose	Read the last measured downstream absolute pressure (<i>tare</i> corrected).
Syntax	"PRLO"
Remarks	The current downstream pressure value (corrected for <i>tare</i>) is returned in the current pressure unit of measure.
Example	Command: "PRLO" Reply: "224.67 kPaa"
See Also	"DP", "PRDP", "PR", "PRHI"

PUNIT(=)	
Purpose	Read or set the pressure display unit of measure.
Syntax	"PUNIT=unit"
Defaults	"PUNIT"
Arguments	unit: The text corresponding to the pressure unit of measure. The pressure unit protocol is the same as the protocol used for front panel entries and displays.
Remarks	This command determines what unit of measure is used to display pressure.
Example	Command: "PUNIT=MPA" Reply: "MPa"
Errors	ERR# 7: The unit is invalid.
See Also	3.3.2

PURGE(=)	
Purpose	Read the progress of or start the purge cycle.
Syntax	"PURGE=period" "PURGE"
Arguments	period: The period of time over which to purge (1 .. 999 seconds). "0" aborts the purge cycle and returns to normal operation.
Remarks	The purge cycle takes the specified time period to complete. The PURGE command is used to first start the purge cycle, and then to query how many seconds are left or if the cycle is complete. While the purge cycle is executing, a 'b' ("busy") will appear in the third character position of the "FR" and the "SR" command replies. The "PURGE" command must be completed or aborted using the "ABORT" command before performing another operation.
Example	Command: "PURGE=30" Reply: "30 sec" Command: "PURGE" Reply: "12 sec" (purge cycle has 12 sec left) Reply: "OK" (purge cycle is complete)
Errors	ERR# 6: The argument is invalid.
See Also	3.2.4.2

RANGE	
Purpose	Read the range designation of the active molbloc.
Syntax	"RANGE"
Remarks	The range designation of the active molbloc is returned in the flow units used to define the range. Note that the effective molbloc range is dependent on the gas being flowed and the molbloc pressure dependent calibration type. Do not assume the usable range is equal to the range designation.
Example	Command: "RANGE" Reply: "10.00 sccm"
See Also	1.2.4.3 and 1.2.4.4, "MOLBLOC", "DEVICE=EXT"
RATE	
Purpose	Read the next available rate of change of flow.
Syntax	'RATE"
Remarks	The next available rate change of flow in the current flow unit of measure per second is returned.
Example	Command: "RATE" Reply: "-0.01 sccm/s"
See Also	3.2.6.1, 3.1.2.4, and 3.3.5
RE	
Purpose	Read the value of Reynolds number representing the current flow through the molbloc as calculated by the molbox RFM.
Syntax	"RE"
Remarks	The Reynolds number varies with the molbloc flow.
Example	Command: "RE" Reply: "82.34"
See Also	3.1.2.4 and 3.2.5
READYCK(=)	
Purpose	Read or set a flag that is cleared by a <i>Not Ready</i> condition.
Syntax	"READYCK=1" "READYCK"
Defaults	"READYCK=1"
Remarks	The internal ready check flag is cleared whenever the molbox RFM reaches a <i>Not Ready</i> (NR) condition. The "READYCK" command will return the status of this flag. This flag can be set only by sending the "READYCK=1" command while the molbox RFM is in a <i>Ready</i> (<*>) condition. If you send the "READYCK=1" command when the molbox RFM is in a <i>Not Ready</i> (NR) condition, the reply will be "READYCK=0". If you set READYCK=1 when the molbox RFM achieves a <i>Ready</i> (R) condition, you can use READYCK later to determine if a <i>Not Ready</i> (NR) condition has occurred. If NR has occurred, READYCK will return "0". If NR has not occurred, READYCK will return "1".
Example	Command: "READYCK=1" (set the flag) Reply: "READYCK=1" Command: "READYCK" (query for flag status) Reply: "READYCK=1" (has been ready since setting flag)
Errors	ERR# 6: The argument is not a 1.
See Also	3.1.2.4, "SR"

REMOTE	
Purpose	Enable remote local lockout operation.
Syntax	"REMOTE"
Remarks	A REMOTE command deactivates the front panel. All front panel controls will be disabled. The REMOTE command can only be canceled by a LOCAL command or by turning OFF the molbox RFM power then re-applying it.
Example	Command: "REMOTE" Reply: "REMOTE"
See Also	"LOCAL"

RES(=)	
Purpose	Read or set the local flow display resolution.
Command	"RES= <i>n</i> "
Query	"RES"
Default	"RES=0.01%"
Arguments	<i>n</i> : Resolution in %FS (1% - 0.01%)
Remarks	The molbox's front panel resolution can be specified with this command. Displayed resolution becomes 10 times smaller than the current RES setting (ie. default = 0.001% FS) when the microrange option is active. The resolution of remote flow measurement replies are always 0.001% FS (0.0001% FS with microrange).
Example	Sent: "RES=.01" Query reply: "0.010%"
Errors	ERR# 6: The argument was out of bounds.
See Also	3.4.9

RESET	
Purpose	Reset the molbox RFM to the default operating parameters.
Syntax	"RESET"
Remarks	The RESET command can be given to return certain molbox RFM settings to a default state. This reset corresponds to the RESET - SETS function from the front panel. The reset process can take up to 10 seconds to complete, so the user must wait this time interval before attempting to communicate to the molbox RFM again.
Example	Command: "RESET" Reply: "RESET"
See Also	3.4.1.7

SN	
Purpose	Read the serial number of the molbox RFM.
Syntax	"SN"
Remarks	Each molbox RFM is serialized. This serial number is also imprinted on the product label on the bottom of the molbox RFM and is displayed in the power up introductory screen.
Example	Command: "SN" Reply: "SN"
See Also	3.4.5.4

SR	
Purpose	Read the next available ready status.
Syntax	"SR"
Remarks	<p>The current <i>Ready/Not Ready</i> status can be read directly using this command. If the reply is "NR" then the flow is <i>Not Ready</i> within the limits set by the stability settings. If the reply is "R" then the flow is <i>Ready</i> within the limits. The status is replied when the next flow measurement is finished.</p> <p>The third character indicates optional additional molbox status information:</p> <p>"r" molbloc flow is over the maximum Reynolds number of 1 200 allowed for a valid measurement.</p> <p>"b" molbox1+ is busy with a <i>tare</i>, leak check or purge cycle which does not allow normal operation.</p> <p>"a" molbox1+ is currently executing an averaging cycle.</p> <p>"P" molbloc-S BPR is too high or molbloc pressure exceeds molbloc calibration pressure limits by 10kPa or more (always causes a <i>Not Ready</i> condition).</p> <p>"F" Measured flow exceeds molbloc calibration flow limit by 5% or more (always causes a <i>Not Ready</i> condition).</p>
Example	<p>Command: "SR"</p> <p>Reply: "R " (Flow measurement is ready)</p> <p>Reply: "NR " (Flow measurement is not ready)</p> <p>Reply: "R a" (average cycle is executing)</p> <p>Reply: "R b" (tare, leak check or purge cycle is executing)</p> <p>"NRP" (BPR is too high for a valid measurement)</p>
See Also	3.1.2.4, "FA", "FR", "READYCK", "SS", "TARESET", "PURGE", "LEAKCK"

SS	
Purpose	Read or set the flow stability required for a <i>Ready</i> condition to occur (flow unit/s).
Syntax	"SS=stab" "SS"
Defaults	"SS=0.1 sccm"
Arguments	stab: The flow stability in flow unit/sec.
Remarks	The stability setting determines whether the flow is <i>ready</i> or <i>not ready</i> . Stability is set in terms of flow. If the rate of change of flow is greater than the current setting, then the status is <i>Not Ready</i> .
Example	<p>Command: "SS=.2"</p> <p>Reply: "0.20 sccm"</p>
Errors	ERR# 6: The stability argument is invalid.
See Also	3.1.2.4 and 3.3.5, "READYCK", "SR"

STDRES(=)	
Purpose	Read or set the molbox's two internal standard resistor values.
Syntax	"STDRES" "STDRES=R0 ₁₀₀ , R0 ₁₁₀ "
Arguments	R0 ₁₀₀ : The 100 ohm standard resistor value (ohms). R0 ₁₁₀ : The 110 ohm standard resistor value (ohms).
Remarks	The standard resistor values are used to periodically calibrate the PRT measurement system. These values are stored in the molbox's factory data area, and should be modified with care. You should not routinely modify these values, as you risk data corruption in doing so. After modifying these values, a calibration of the PRT measurement system will occur and an updated measurement of the PRTs will not be available until this is complete (about 20 seconds)
Example	Command: "STDRES=100.0022,110.0132" Reply: "100.0022 Ohms, 110.0132 Ohms"
Errors	ERR# 6: Values are invalid (must be between 1 and 199).
See Also	"OHMS", "TEMP"

TARE	
Purpose	Read the current <i>tare</i> conditions and the current <i>tare</i> .
Syntax	"TARE"
Remarks	<p>The user should set the molbox RFM valves to the <i>tare</i> condition (see "TARESETUP") and check the <i>tare</i> conditions before taring the internal transducers (see "TARESET"). The returned data will allow the user to determine if the current conditions will allow a valid <i>tare</i>. The reply contains three or five fields which are separated by commas.</p> <p>The first field starts with an "R" if the system is ready to <i>tare</i> or else an "NR". The "R" must be present to <i>tare</i> the transducers. The system is ready to <i>tare</i> only if the current difference in pressure [Pa] between the up and down stream RPTs without <i>tare</i> is below 9999 Pa. If the microrange option is present, then the microrange RPT pressure without <i>tare</i> must be below 999 Pa. The actual pressure rate of change in Pa/sec follows this text.</p> <p>The second field displays the current difference in pressure [Pa] between the up and down stream RPTs without <i>tare</i>. The third field shows the last <i>tare</i> value.</p> <p>If the optional microrange option is present, then the microrange RPT pressure [Pa] without <i>tare</i> will appear in a fourth field, and the fifth field shows the last microrange <i>tare</i> value. All returned values are in Pascal [Pa].</p>
Example	Command: "TARE" Reply: "R 0 Pa/s, 115 Pa, 108 Pa" (no microrange) Command: "TARE" Reply: "R 0 Pa/s, 115 Pa, 108 Pa, 6 Pa, 3 Pa (with microrange)"
See Also	3.2.4.1, "TARESET", "TARESETUP"

TARESETUP(=)	
Purpose	To prepare the molbox RFM to be <i>tared</i> and to return the unit to normal operation after a <i>tare</i> has been completed.
Syntax	"TARESETUP=mode "TARESETUP"
Defaults	"TARESETUP=OFF"
Arguments	mode: "OFF" Allows normal operation of the molbox RFM. "UP" Connects both of the absolute RPTs to the upstream pressure. Also connects both '+' and '-' sides of the microrange RPT, if present, to the upstream pressure (microrange RPT bypassed - inactive). "DN" Connects both of the absolute RPTs to the downstream pressure. Also connects both '+' and '-' sides of the microrange RPT, if present, to the downstream pressure (microrange bypassed - inactive).
Remarks	Before the molbox RFM can be <i>tared</i> , the "TARESETUP" command must be used to configure the internal RPT connections properly. After the <i>tare</i> operation is complete, the "TARESETUP" command must again be used to restore the RFM to normal operation. The "ABORT" command can also return operation to normal. The normal order of remote commands for a <i>tare</i> operation: "TARESETUP=UP" or "TARESETUP=DN" configures the molbox RFM for a <i>tare</i> . "TARE" queries the molbox RFM for current conditions until it is ready for <i>tare</i> . "TARESET" <i>tares</i> the molbox RFM when the "TARE" query has shown it is ready. "TARESETUP=OFF" returns the molbox RFM to normal measurement mode. NOTE: The "TARESET" command takes 5 to 7 seconds to reply due to the amount of time required to acquire a valid <i>tare</i> value.
Example	Command: "TARESETUP=UP" Reply: "UP"
Errors	ERR# 6: An argument is invalid.
See Also	3.2.4.1, "TARE", "TARESET"; "ABORT"

TARESET(=)	
Purpose	To automatically <i>tare</i> the upstream and downstream RPT (and microrange RPT if present) or set the <i>tare</i> to a user defined value.
Syntax	"TARESET=tare(,microrange tare) "TARESET"
Defaults	"TARESET=0(,0)"
Arguments	tare: The <i>tare value</i> (-9999 to 9999 Pa). microrange The optional microrange transducer <i>tare value</i> (-999 to 999 Pa). tare:
Remarks	"TARESET" will automatically <i>tare</i> the molbox RFM only if the <i>tare</i> results are within the limits given (see the "TARE" command). Use the "TARESETUP" command to prepare the unit to be <i>tared</i> , and the "TARE" command to check if conditions are valid. After you have completed taring the unit, use the "TARESETUP" command or the "ABORT" command to return the unit to normal operating conditions. If the microrange option is installed, it is also <i>tared</i> . You can also manually set the <i>tare value(s)</i> using the "TARESET=tare" command. All pressure values are always in Pascal [Pa]. While the <i>tare</i> cycle is executing, a 'b' ("busy") will appear in the third character position of the "FR" and the "SR" command replies. NOTE: This command typically takes 5 to 7 seconds to complete if performing a <i>tare</i> (no arguments given).
Example	Command: "TARESET" Reply: "66 Pa" Reply: "66 Pa, 7 Pa" (microrange option installed)
Errors	ERR# 6: An argument is invalid. ERR# 25: One of the <i>tare values</i> exceed <i>tare</i> limits.
See Also	3.2.4.1, "TARE", "TARESETUP", "ABORT"

TCAL(=)	
Purpose	Read or set the molbox RFM temperature calibration
Syntax	"TCAL= <i>adder, mult, date</i> " "TCAL"
Arguments	<i>adder</i> : Temperature adder in the current temperature units. <i>mult</i> : Temperature multiplier. <i>date</i> : Date (YYYYMMDD)
Remarks	The temperature calibration for active channel is applied to the displayed molbloc temperature.
Example	Command: "TCAL=0.25, 1.003,20090226" Reply: "0.250, 1.0030,20090226"
Errors	ERR# 2: The <i>date</i> argument is invalid
See Also	3.2.2, "TUNIT", "STDRES"

TEMP	
Purpose	Read the temperature of the active molbloc in the current unit of measure.
Syntax	"TEMP"
Remarks	The upstream and downstream temperatures as well as average molbloc temperature are returned in the current temperature units. They are replied in the order of: <i>Average, upstream, downstream</i> An error will be returned if there is a problem reading the molbloc PRTs.
Example	Command: "TEMP" Reply: "17.85 C, 17.84 C, 17.86 C"
Errors	ERR# 37: There is an error in the molbox RFM PRT measurement.
See Also	3.2.5, "TUNIT"

TIME(=)	
Purpose	Read or set the internal clock time.
Syntax	"TIME" "TIME=hh:mm:m"
Arguments	hh:mmxs: The time to set in the format where hh is the hours from 1 to 12, mm is the minutes from 1 to 59 followed by "am" or "pm".
Example	Command: "TIME=1:22am" Reply: "01:22am"
Errors	ERR# 7: The time given is invalid.
See Also	3.4.5.3

TOTAL(=)	
Purpose	Read the progress of or start a new totalize cycle.
Syntax	"TOTAL=period" "TOTAL"
Arguments	period: The period to totalize 00:00:01 to 99:59:59 (HH:MM:SS). "0" stops the totalize cycle before it is complete.
Remarks	The totalizing cycle accumulates the total mass or volume flowed over a set period, or the user can stop the cycle early if desired to use a shorter period than specified. The reply to a "TOTAL" query provides the current total, and the elapsed time period in the HH:MM:SS format. The cycle is complete when the total flow is preceded by 'R' (<i>Ready</i>). If the unit is actively totalizing, an "NR" (<i>Not Ready</i>) precedes the total flow.
Example	Command: "TOTAL=00:10:00" Reply: "NR 0.0000 ucc, 00:00:00" (new cycle has started) Command: "TOTAL" Reply: "NR 5.2347 ucc, 00:08:21" (cycle has run 8 min, 21 sec) Reply: "R 6.2634 ucc, 00:10:00" (cycle is complete) Command: "TOTAL=0" Reply: "R 5.2347 ucc, 00:08:21" (cycle has completed early)
Errors	ERR# 6: The argument is invalid.
See Also	3.2.6.4

TUNIT	
Purpose	Read or set the molbloc temperature unit of measure.
Syntax	"TUNIT=unit" "TUNIT"
Arguments	unit: 'C' for Celsius or 'F' for Fahrenheit.
Remarks	The temperature unit is used for reporting the molbloc temperature, and for setting various other temperature settings.
Example	Command: "TUNIT" Reply: "C"
Errors	ERR# 6: The unit argument is invalid.
See Also	3.3.3, "TEMP"

UDU(=)	
Purpose	Read or set the user definable pressure unit.
Syntax	"UDU" "UDU=text, coef"
Arguments	text: The text to use to identify the unit. It can be up to 4 characters wide. This will be the text used to specify the unit if selecting it remotely, and that appears on the molbox RFM. coef: The coefficient to convert Pascal [Pa] to the user unit. The pressure (in Pa) will be multiplied by this coefficient before being displayed.
Defaults	"UDU=UNIT, 1"
Example	Command: "UDU=Bar2, .00001" Reply: "Bar2, 0.000010"
Errors	ERR# 2: The text argument is longer than 4 characters. ERR# 6: The coef argument is invalid.
See Also	3.3.2, "PUNIT"

USERCAL(=)	
Purpose	Read or set the user flow measurement adjustment.
Syntax	"USERCAL= <i>adder</i> , <i>mult</i> " "USERCAL"
Defaults	"USERCAL=0, 1"
Arguments	<i>adder</i> : The flow <i>adder</i> in the current flow unit and gas type (0 to FS). <i>Mult</i> : The flow <i>multiplier</i> (0.1 to 2).
Remarks	The user definable adjustment lets the user modify the measured flow. The <i>adder</i> and <i>multiplier</i> are separated by a comma. The <i>adder</i> is in the current flow unit.
Example	Command: "USERCAL=.58,.995" Reply: "0.58 sccm, 0.995000"
Errors	ERR# 6: The <i>adder</i> or <i>multiplier</i> argument is invalid.
See Also	3.3.6, "PCAL(=)"

UTEMP	
Purpose	Read or set the temperature reference used for the volumetrically based mass flow unit with user defined reference temperature.
Syntax	"UTEMP=temp" "UTEMP"
Defaults	"UTEMP=0" (°C)
Arguments	temp: The reference temperature in the current temperature unit of measure.
Remarks	This temperature reference is used by the user defined units.
Example	Command: "UTEMP=20" Reply: "20.00 C"
See Also	3.2.3, 3.2.3.2, and 3.2.3.3, "FUNIT", "TUNIT"

VER	
Purpose	Read the molbox RFM version.
Syntax	"VER"
Remarks	The software version of the molbox RFM can be read. This is useful for checking for the presence of the molbox RFM and for reference purposes.
Example	Command: "VER" Reply: "FLUKE RFM Ver1.20"

VLM(=)	
Purpose	Read or set the volume flow unit of measure pressure temperature conditions.
Syntax	"VLM=pres(,temp)" "VLM"
Defaults	"VLM=101.325 kPaa, 20°C"
Arguments	pres: The user defined pressure in the current pressure unit. Temp: The user defined temperature in the current temperature unit. If this field is omitted, and just the pressure is given, then the molbloc temperature will be used as temperature.
Remarks	The flow volume units "ccm", "lm", "lh", "m3m", "m3h", "cfm" and "cfh" require pressure and a temperature conditions to be specified by the user.
Example	Command: "VLM=200" Reply: "200.00 kPaa" (molbloc temp will be used) Command: "VLM=200, 15" Reply: "200.00 kPaa, 15°C" (user defined temp will be used)
Errors	ERR# 6: One of the arguments is invalid.
See Also	3.2.3, 3.2.3.1, and 3.2.3.4, "FUNIT"

ZOFFSET:HI(=) and ZOFFSET:LO(=)	
Purpose	Read or set the AutoZ pressure offset (P_{offset}) for the high ("HI") or low ("LO") absolute RPT .
Command:	"ZOFFSET:HI = <i>offset</i> "
Query:	"ZOFFSET:LO = <i>offset</i> " "ZOFFSET:HI" "ZOFFSET:LO"
Defaults	"ZOFFSET:HI = 0.0" "ZOFFSET:LO = 0.0"
Arguments	<i>offset</i> : The RPT pressure offset ("Poffset") in Pa.
Remarks	The pressure offset (P_{offset}) for the specified RPT (HI or Lo) can be accessed with this command. Using this program message overwrites the current offset, so caution must be used. Changes made using this program message take effect immediately.
Example	Sent: "ZOFFSET:LO=2.1" Reply: " 2.10 Pa"
Errors	ERR# 6: One of the arguments is out of range.
See Also	3.4.4.4, "AUTOZERO" command

4.4 Status System

The status system includes the status reporting system which reports general molbox RFM events. The user can select which molbox RFM events will cause a status change event. These events are then reported to the status system (bit7 and bit3 of the status byte register), which also must be configured for the STATus subsystem to generate the service requests described in Section 4.4.1.

There are two 16 bit event registers that make up the top layer of the status subsystem. The OPERation status register handles conditions that are normal for the molbox RFM. The QUEStionable status register handles events that could cause measurements to be made under questionable conditions.

Other registers layered below these two registers provide the structure necessary to handle the two RPT channels and to enable the events and event transitions. Bit15 of all of these registers is not used because Bit15 represents a sign bit on some computer systems.

4.4.1 Status Reporting System

The molbox RFM status reporting system is used to track and report system status and errors. The status subsystem is layered under and reports to the status reporting system. It follows the model of the IEEE Std 488.2 and works for the COM1 and the IEEE-488 port with slight differences. The molbox RFM can be programmed to respond to various status conditions by asserting the SRQ of the IEEE-488 interface. The COM1 port cannot be supported in this manner, so polling must be used.

4.4.1.1 Status Byte Register

The molbox RFM contains an 8 bit status byte register that reflects the general status of the molbox RFM.

Table 41. Status Byte Register

OPER	RQS/MSS	ESB	MAV	N/A	ERROR	N/A	RSR
(128)	(64)	(32)	(16)	(8)	(4)	(2)	(1)

This register is affected by the molbox RFM reply output queue, the error queue, the Standard Event Status register the Ready Event Status register, and the STATus subsystem.

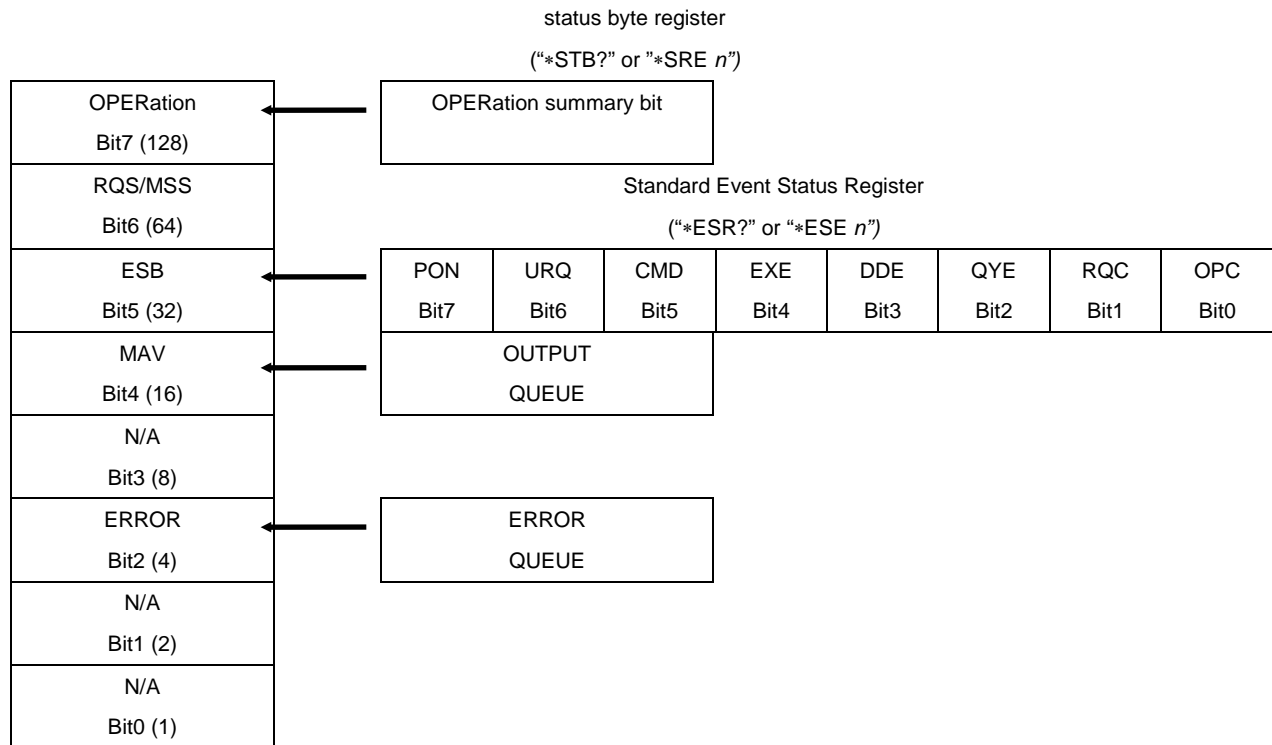

Figure 14. Status Byte Register

The status byte register can be read using the “*STB?” query, or by performing a serial poll on the IEEE-488 bus. If you read this using a serial poll then Bit 6 is the RQS. If the “*STB?” query is used, then Bit 6 is the MSS bit. All of the other bits are common to both types of query.

Each of these status bits can cause a SRQ to occur. The Service Request Enable Register (“*SRE” program message) determines which of these flags are able to assert the SRQ line. This enable register has a matching set of bits that each will enable the designated bit to cause a SRQ, except for the RQS/MSS bit(s) which cannot cause a SRQ. If you set this register to 20 (\$14 hex), an SRQ will occur if the MAV or the ERROR bit are set. The description of these bits are given as:

- OPER: OPERational event register summary bit (Bit 7)
- This bit is not supported by the molbox RFM.
- RQS: Requested Service (Bit 6)
- Indicates that the SRQ line of the IEEE-488 interface has been asserted by the molbox RFM. This bit is cleared when a serial poll is performed on the molbox RFM, and is a part of the status byte register when read using a serial poll. This bit does not apply if the COM1 port is being used.
- MSS: Master Summary Status (Bit 6)
- Indicates that an event or events occurred that caused the molbox RFM to request service from the Host, much like the RQS bit. Unlike the RQS bit, it is READ ONLY and can be only cleared when the event(s) that caused the service request are cleared.
- ESB: Event Summary Bit (Bit 5)
- Indicates if an enabled bit in the Standard Event Status Register became set. (See Section 4.4.1.2.)
- MAV: Message Available Bit (Bit 4)

- Indicates that at least one reply message is waiting in the molbox RFM IEEE-488 output queue.
- ERR: Error Queue not empty (Bit 2)
- Indicates that at least one command error message is waiting in the molbox RFM IEEE-488 error message queue. Use the “SYSTem:ERRor?” query to get this message.

4.4.1.2 Standard Event Register

The molbox RFM contains an 8 bit Standard event register that reflects specific molbox RFM events that are not RPT dependent. Enabled events in this register will set or clear the ESB bit of the status byte register.

Table 42. Standard Event Register

PON	URQ	CMD	EXE	DDE	QYE	RQC	OPC
(128)	(64)	(32)	(16)	(8)	(4)	(2)	(1)

This register can be read using the “*ESR?” query. Each of these status bits can set the ESB bit of the status byte register, causing a SRQ to occur IF the ESB bit is enabled to do so. The Standard Event Status Enable Register (“*ESE” program message) determines which of these flags are able to assert the ESB bit. The description of these bits are given as:

- PON: Power On (Bit 7)
 - Indicates that the molbox RFM power has been cycled since the last time this bit was read or cleared.
- URQ: User Request (Bit 6)
 - Indicates that the molbox RFM was set to local operation manually from the front panel by the user (pressing the ESC key).
- Command Error (Bit 5)
 - Indicates that a remote command error has occurred. A command error is typically a syntax error in the use of a correct program message.
- EXE: Execution Error (Bit 4)
 - Indicates if a remote program message cannot be processed due to device related condition.
- DDE: Device Dependent Error (Bit 3)
 - Indicates that an internal error has occurred in the molbox RFM (e.g., a transducer time-out).
- QYE: Query Error (Bit 2)
 - Indicates that an error has occurred in the protocol for program message communications. This is typically caused by a program message being sent to the molbox RFM without reading a waiting reply.
- RQC: Request Control (Bit 1)
 - This bit is not supported as the molbox RFM cannot become the active controller in charge.
- OPC: Operation Complete (Bit 0)
 - Indicates that the molbox RFM has completed all requested functions.

Notes

5. Maintenance, Adjustments And Calibration

5.1 Product Overview

molbox RFM was designed for maintenance free operation. No maintenance is required other than:

- **Taring (zeroing) of Reference Pressure Transducers (RPTs).** This function is not a separate MAINTENANCE function, it is part of regular operation (see Section 3.4.4.1).
- **AutoZero of Reference Pressure Transducers (RPTs):** Regular rezeroing of the RPTs absolute measurement mode to a barometric reference standard using the AutoZ function is recommended (see Section 3.4.4.4).
- **Reference Pressures Transducer (RPT) Calibration.** An annual recalibration cycle is recommended. See Section 5.2 for instructions on RPT calibration.
- **Ohmic Measurement System Verification.** A five year verification interval is recommended. See Section 5.3 for instructions.
- **molbloc Calibration.** molblobs can be calibrated separately from molbox RFM. A one year recalibration cycle is recommended. Due to the costs associated with maintaining the flow standards needed to calibrate molblobs, most users return their molblobs to Fluke Calibration in Phoenix, Arizona, USA rather than supporting the calibrations themselves. molbloc calibration is not covered in this manual. **CalTool for molblobs** software is available for facilities desiring to perform molbloc calibrations. Contact your Fluke Calibration representative for additional information if needed.

This section provides information on maintenance, adjustment and calibration procedures and recommended overhaul procedures.

Note

Calibration, maintenance and repair services for molbox RFM are offered by a Fluke Calibration Authorized Service Provider (See Table 34).

⚠ Caution

- molbox RFM is a sophisticated measuring instrument with advanced on-board features and functions. Before assuming that unexpected behavior is caused by a system defect or breakdown, use this manual and other training facilities to become thoroughly familiar with molbox RFM operation. For rapid assistance in specific situations and other troubleshooting information, see Section 6.
- molbox RFM is covered by a limited one year warranty. Unauthorized service or repair during the warranty period is undertaken at the owner's risk and may cause damage that is NOT covered under product warranty and/or may void the product warranty.

5.2 Calibration of Reference Pressure Transducers (RPTs)

5.2.1 Principle

molbox RFM has two absolute Reference Pressure Transducers (RPTs):

- One to measure molbloc upstream pressure
- One to measure molbloc downstream pressure

If molbox RFM is equipped with the microrange option (see Section 3.1.5), it also has a third low differential RPT.

To calibrate an RPT, pressures from a pressure standard are applied to the RPT at ascending and descending pressure points over the RPT range. The pressure defined by the standard and the corresponding RPT readings are recorded at each point. After all of the pressures have been applied and recorded, adjustments are made to fit the RPT pressure readings to the standard. Fitting the readings means performing a least squares linear regression to arrive at the lowest value of the residual of errors of the transducer relative to the standard. The transducer readings are adjusted by user settable coefficients: *PA* (a pressure *adder* or offset) and *PM* (a pressure *multiplier* or span set) (see Section 5.2.1.1).

molbox RFM provides complete local and remote access and control of RPT calibration parameters. Section 5.2 of this manual provides complete information on equipment needed and recommended procedures for calibration of the molbox RFM RPTs.

Caution

CalTool for RPTs software provided with the molbox RFM supports the calibration process of molbox RFM RPTs. CalTool and its documentation are provided on a General Accessories CD (white) with each new system. Most users should use CalTool software to assist in the calibration of the molbox RFM. The latest version of this software is always available for download, free of charge, from www.flukecal.com.

CalTool for RPTs steps the operator through the complete reference transducer calibration procedure. It is capable of applying the necessary test pressures, gathering the data, calculating the optimum calibration coefficients, evaluating the calibration results, writing the new coefficients to the molbox RFM and generating the calibration reports. (See the CalTool for RPTs manual also found on the General Accessories CD and www.flukecal.com.) molbox RFM also provides complete front panel and remote access to RPT calibration parameters so that the RPT calibrations can be performed without using CalTool software (see the following sections).

molbox RFM also provides complete local and remote access to RPT calibration coefficients so that RPT calibrations can be performed without using CalTool software if desired (see Section 5.2.5).

Caution

CalTool for RPTs software provided with the molbox RFM supports the calibration process of molbox RFM RPTs. The CalTool program and its manual are provided on the General Accessories Disk with the new molbox RFM. Most users should use CalTool software to assist in the calibration of molbox RFM RPTs.

5.2.1.1 PA and PM Coefficients

The coefficients used to adjust RPT readings are designated *PA* (a pressure *adder* or offset) and *PM* (a pressure *multiplier* or span set). The coefficients affect the RPT reading following:

$$\text{Corrected reading} = (\text{uncorrected reading} \cdot PM) + PA$$

PA is expressed in pressure (always the SI unit, Pascal [Pa]).

PM is dimensionless.

There are individual *PA* and *PM* values for each of molbox RFM's two absolute pressure RPTs (and for the differential pressure RPT if the microrange option is present) (see Section 3.1.5). The *PA* and *PM* values currently in use for each RPT can be viewed in the CALIBRATION function. If adjustments are necessary when calibrating an RPT, the adjustments are made by adjusting the *PA* and *PM* values (see Section 5.2.4).

Caution

As editing *PA* and *PM* values will change RPT calibration, they should only be edited by qualified personnel as part of the calibration process. Caution should be taken to avoid accidental editing. For information on preventing access to calibration information, see Section 3.6.2.

Note

A new molbox RFM is delivered with user *PA* and *PM* values set to zero (0) and one (1) respectively for all RPTs. This does NOT mean that the molbox RFM has NOT been calibrated. For the original factory calibration, privileged factory coefficients are used for calibration adjustment. This allows a new molbox RFM to be delivered with “virgin” calibration coefficients of *PA* = 0 and *PM* = 1.

5.2.2 Equipment Required

5.2.2.1 upstream and downstream ABSolute RPTs

Gas operated pressure standard with the following characteristics:

- **Able to apply absolute pressure in 20 % increments between atmosphere and 525 kPa (77 psi).** It is NOT necessary that the calibration pressure standard used apply precisely the nominal pressure value of a calibration point as long as the exact value of the applied pressure is known. A lower range may be used if the molbox RFM will only be used at lower pressures. The low point does not have to be zero absolute. Preferably, a value under atmosphere will be used, but atmospheric pressure can be used as the low point if necessary.
- **Accuracy of ± 0.015 % of reading or better,** if molbox RFM flow measurement accuracy specifications are to be obtained. A lower accuracy standard may be used but molbox RFM flow measurement accuracy may be degraded from published specifications proportionally.

⚠ Caution

Use only clean dry gas sources when calibrating molbox RFM RPTs. Contaminating molbox RFM with liquids can cause out of tolerance measurements and may require special factory cleaning procedures.

Note

Fluke Calibration manufactures a variety of pressure standards suitable for calibration of molbox RFM RPTs. Contact Fluke Calibration for additional information.

5.2.2.2 Differential (microrange) RPT

Gas operated pressure standard with the following characteristics:

- **Able to apply gauge pressure in 20 % increments between zero and 12.5 kPa (2 psi).** It is NOT necessary that the calibration pressure standard apply precisely the nominal pressure value of each calibration point as long as the exact value of the applied pressure is known.
- **Accuracy of ± 2 Pa (0.0003 psi) or better,** if best molbox RFM accuracy is to be obtained. A lower accuracy standard may be used but molbox RFM accuracy may be degraded from published specifications proportionally.

⚠ Caution

Use only clean dry gas sources when calibrating molbox RFM RPTs. Contaminating molbox RFM with liquids can cause out of tolerance measurements and may require special factory cleaning procedures.

Note

Fluke Calibration manufactures a variety of pressure standards suitable for calibration of molbox RFM RPTs. Contact Fluke Calibration for additional information.

5.2.3 Set-Up and Preparation**5.2.3.1 UPSTREAM AND DOWNSTREAM Absolute RPTS**

To set-up and prepare the molbox RFM for calibration of its upstream and downstream absolute RPTs:

- ① Set the molbox RFM on a stable surface near the calibration standard at a height as close as possible to the calibration standard's reference height. Consider the connections that need to be made to the molbox RFM rear panel pressure quick connectors and access to the front panel display and keypad.
- ② Connect the calibration standard output to the molbox RFM rear panel UP (HI) port. In the run calibration mode (see Section 5.2.4.1), both absolute RPTs are connected to the UP (HI) port and isolated from the DOWN (LO) port (see **Figure 15**). Use one of the quick connector stems (Fluke P/N 3068652), equivalent to Swagelok SS-QM2-S-200) supplied with the molbox RFM accessories to make the connection. The fitting on the quick connector stem that must be mated to is a compression type for 1/8 in. tube.

5.2.3.2 MICRORANGE Differential RPT

To set-up and prepare the molbox RFM for calibration of its microrange differential RPT:

- ❶ Set the molbox RFM on a stable surface near the calibration standard. Consider the connections that need to be made to the molbox RFM rear panel pressure quick connectors and access to the front panel display and keypad.
- ❷ Connect the calibration standard output to the molbox RFM rear panel UP (HI) port. In the run calibration mode (see Section 5.2.4.1), the microrange differential RPT high side is connected to the UP (HI) port and the low side is connected to the DOWN (LO) port (see **Figure 16**). Open the DOWN (LO) port to atmosphere by installing the accessory quick connector. If the calibration standard has a “low”, “minus” or “reference” port, consider connecting it to the molbox RFM DOWN (LO) port to assure that the calibration standard and molbox RFM are at the same ambient pressure. Use a quick connector stem (Fluke P/N 3068652), equivalent to Swagelok SS-QM2-S-200) supplied in the molbox RFM accessories to make the connection. The fitting on the quick connector stem that must be mated to is a compression type for 1/8 in. tube.

⚠ Caution

To properly calibrate the microrange RPT, its low side must be open to atmosphere or connected to the low side of the calibration reference. The molbox RFM DOWN (LO) quick connector contains a shut-off valve so leaving the quick connector “open” actually isolates the low side of the microrange RPT. Therefore, one of the two quick connector stems (Fluke P/N 3068652), equivalent to Swagelok SS-QM2-S-200) supplied in the molbox RFM accessories must be connected to be sure that the low side of the RPT is vented. The accessory stems do not have shut-off valves. The quick connector stems on the molbox to molbloc tubes also have shut-off valves so they are closed when not connected.

5.2.4 Viewing and editing RPT READINGS AND Calibration Information

⚠ Caution

Editing RPT calibration information will affect molbox RFM pressure measurements and can cause out of tolerance flow measurements. RPT calibration information should only be edited by qualified personnel as part of the calibration process. Caution should be taken to avoid accidental editing. For information on preventing access to calibration information see Section 3.6.2.

○ PURPOSE

To read the output of molbox RFM RPTs in calibration mode; view and edit the calibration coefficients and calibration date.

○ PRINCIPLE

The molbox RFM CAL function contains all of the functions needed to perform RPT calibrations in one menu area.

This includes:

- Viewing molbox RFM RPT outputs (pressure readings) directly without the *tare* applied and configured for application of calibration pressures to run the calibration (see Section 5.2.4.1).
- Viewing *PA* and *PM* calibration coefficients and the calibration date (see Section 5.2.4.2).
- Editing *PA* and *PM* calibration coefficients and the calibration date (see Section 5.2.4.2).

Note

See Section 5.2.1 for information on molbox RFM calibration coefficients (*PA* and *PM*) and their proper use.

5.2.4.1 Viewing RPT outputs

○ OPERATION

To view the molbox RFM RPT outputs press [SPECIAL] and select <4cal>, <1pressure>.

The display is:

```
Select RPT: 1upstrm
            2dnstrm 3micro
```

The <3micro> option is not present if the molbox RFM does not have the microrange option (see Section 3.1.5). Select the desired RPT and then select <1run>.

Selecting <3micro> causes a warning message to appear concerning possible overpressure of the microrange RPT. To view the microrange RPT differential reading, the microrange bypass valve will be operated to connect the microrange RPT to the differential pressure (see **Figure 16**). If the differential pressure is too high, the microrange RPT may be overpressured and damaged (see Section 3.1.6). Be sure the differential pressure between the molbox RFM UP (HI) and DOWN (LO) ports does not exceed 13 kPa (2 psi), then press [ENTER] to proceed.

If the selection was <1upstrm> or <2dnstrm>, molbox RFM's internal valves operate to connect both absolute RPTs to the upstream pressure port (see **Figure 15**).

The display is:

```
Upstrm zRPTz dwnstrm
97.830 kPaa 97.825
```

The upstream absolute RPT reading is on the left and the downstream absolute reading is on the right.

If the AutoZ function is turned on, the AutoZ correction is applied to these pressure values and the “z” indicators are present as shown above (see Section 3.4.4.4). If AutoZ is off, the correction is not applied and the indicators are not present.

The values displayed are the readings for the RPTs with the current *PA* and *PM* calibration coefficients applied but without the *tare* applied (see Sections 5.2.1.1 and). Both the upstream and downstream absolute RPTs are shown together because they are usually calibrated simultaneously.

Pressing [ESCAPE] or [ENTER] returns to the previous screen.

⚠ Caution

Selecting <3micro> will put the microrange RPT into service by operating the microrange bypass valve. If the differential pressure present is > 13 kPa (2 psi), damage to the microrange RPT may result. Be sure differential pressure is < 13 kPa (2 psi) before pressing [ENTER] to proceed (see Section 3.1.6). Do not apply > 13 kPa (2 psi) to the microrange RPT or damage may result.

Note

The RPT readings viewed by pressing [SPECIAL] and selecting <4cal> DO NOT have the *tare* applied and are valid for RPT calibrations. The RPT readings viewed by pressing [P&T] DO have *tare values* applied and therefore should not be used for taking RPT calibration data (see Section 3.4.4.1 for information on *tare values*)

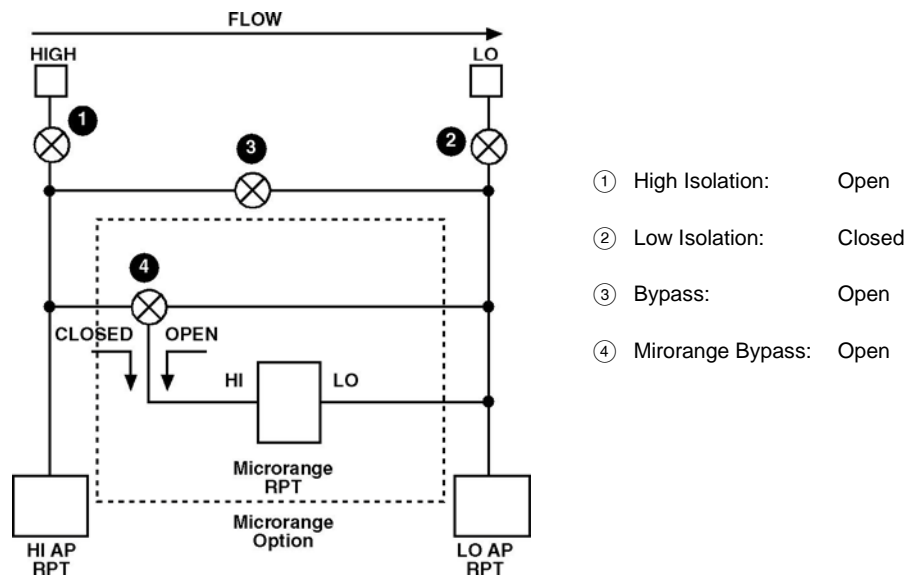

Figure 15. molbox RFM
Internal Pneumatic Schematic – RUN UPSTREAM OR DOWNSTREAM
ABSOLUTE RPT CALIBRATION

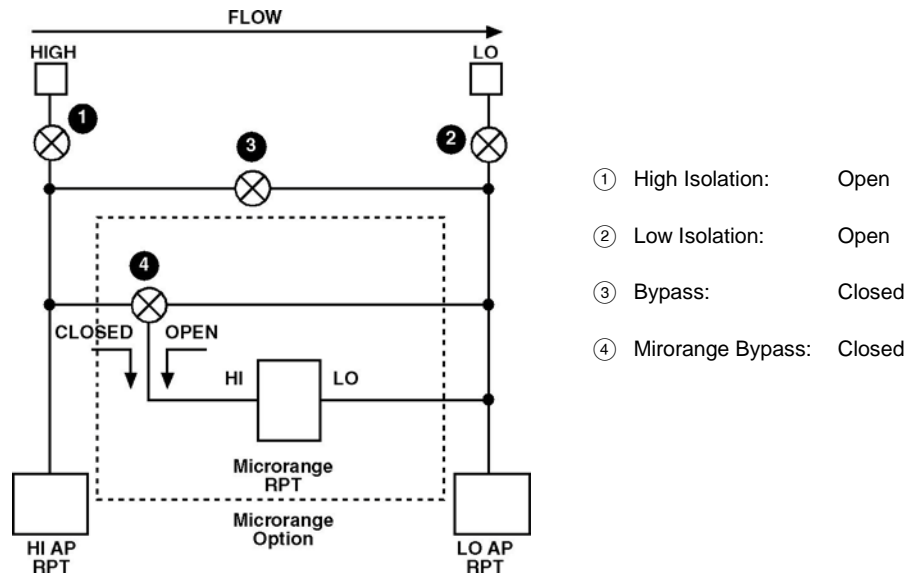

Figure 16. molbox RFM
Internal Pneumatic Schematic – RUN MICRORANGE DIFFERENTIAL RPT CALIBRATION

5.2.4.2 Viewing and Editing rpt PA, PM and Calibration date

○ PURPOSE

To view or edit PA and PM calibration coefficients (see Section 5.2.1.1) and the calibration date for each Reference Pressure Transducer (RPT). Capability to view and edit the values of the reference resistors used by molbox RFM’s ohmic measurement system (see Section 5.3) is also provided here. This capability is normally used only by a Fluke Calibration Authorized Service Provider.

⚠ Caution

Editing RPT and/or reference resistor calibration information will affect molbox RFM pressure and/or temperature measurements and can cause out-of-tolerance flow measurements. RPT calibration information should only be edited by qualified personnel as part of the calibration process. Caution should be taken to avoid accidental editing. For information on preventing access to calibration information see Section 3.6.2).

○ OPERATION

Press [SPECIAL] and select <4cal>, <1pressure>. Select the desired RPT: <1upstrm> or <2dnstrm> or <3micro>. Then select <2view> to view information only or <3edit> to make changes to calibration information.

The display is:

1. Current adder (always in Pascal [Pa]. This is an edit field if <3edit> was selected.
2. Indication of which RPT calibration information is being viewed/edited.
3. Current multiplier (dimensionless). This is an edit field if <3edit> was selected.

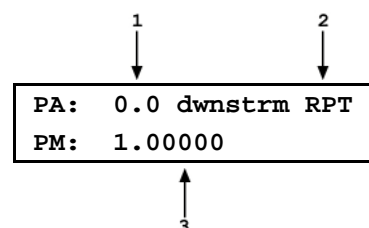

If **<3edit>** was selected, edit the values of *PA* and *PM* as desired. Pressing **[ESCAPE]** returns to the **<1run 2view 3edit>** screen without making changes. Press **[ENTER]** to continue.

The display is:

1. Current calibration date in YYYYMMDD format for the selected RPT. This is an edit field if **<3edit>** was selected. The default date is 19980101.

Dnstrm RPT cal date: 20030214

↑
1

If **<3edit>** was selected, edit the calibration date as desired using a YYYYMMDD format. Pressing **[ESCAPE]** returns to the **<1run 2view 3edit>** screen without making changes. Press **[ENTER]** to continue. If **<3edit>** was selected and changes have been made to *PA*, *PM* or the calibration date, a confirmation screen is presented to **<Activate changes>**. Pressing **[ESCAPE]** or selecting **<1no>** returns to the **<1run 2view 3edit>** screen without making changes. Selecting **<2yes>** activates changes and returns to the **<1run 2view 3edit>** screen.

Note

- There is a specific calibration date for each RPT. Changing the calibration date of one RPT does not change the others.
- The value of *PA* is always in Pascal [Pa]. The value of *PM* is dimensionless.

5.2.5 RPT Calibration/Adjustment Procedure Without Using CALTOOL for RPTs Software

⚠ Caution

Most users should use CalTool for RPTs software to assist in the calibration of molbox RFM reference pressure transducers. CalTool for RPTs and its documentation are provided on the General Accessories Disk delivered with molbox RFM. Whether using CalTool or not, before proceeding to calibrate molbox RFM RPTs, Sections 5.2.1 through 5.2.5 of this manual should be reviewed thoroughly.

The standard molbox RFM RPT calibration procedure is:

- 1 Determine the RPT(s) to be calibrated (upstream and downstream, or microrange if present). The upstream and downstream absolute RPTs are calibrated simultaneously.
- 2 Set-up and prepare the molbox RFM for calibration of the selected RPT(s) (see Sections 5.2.2 and 0).
- 3 Press **[SPECIAL]** and select **<4cal>**, **<1pressure>**, **<1upstrm, 2dnstrm or 3micro>**, **<2view>** to read and record the current values of *PA* and *PM* for the RPT(s) to be calibrated (see Section 5.2.4.2).
- 4 Press **[SPECIAL]** and select **<4cal>**, **<1pressure>**, **<1upstrm, 2dnstrm or 3micro>**, **<1run>** to display the real time pressure readings of the RPT(s) to be calibrated (see Section 5.2.4.1).
- 5 Apply the calibration pressures (generally 20 % increments ascending and descending) for the RPT(s) recording the pressure applied by the standard and the molbox RFM RPT(s) reading(s) at each calibration point.

The standard calibration range for the upstream and downstream absolute RPTs is 70 to 550 kPa absolute (10 to 80 psia). The standard calibration range for the microrange

differential RPT is 0 to 12.5 kPa (0 to 1.8 psi). Dwell at least 30 seconds after setting the reference pressure at each point to allow full stabilization. The data recorded is the "as received" data for this calibration.

- ⑥ Enter the calibration pressure and RPT reading for each point into a spreadsheet. Calculate the "non-corrected" RPT readings by backing out the as received *PA* and *PM* recorded in Step ⑤ above, following:

$$\text{non-corrected reading} = (\text{corrected reading} - PA) / PM + Poffset$$

- ⑦ Perform a best fit linear regression to find the offset and slope that best fit the non-corrected RPT readings to the calibration standard pressures. Most commercial spreadsheet products have a standard function to perform a linear regression. The offset, in Pascal [Pa], is the new value of *PA*, the slope is the new value of *PM*.
- ⑧ Press [**SPECIAL**] and select <4cal>, <1pressure>, <1upstrm, 2dnstrm or 3micro>, <3edit> to write the new values of *PA* (always in Pascal) and *PM* and the new calibration date (YYYYMMDD) for the RPT(s) that is (are) being calibrated (see Section 5.2.4.2).
- ⑨ Calculate "as left data" for the calibration:

$$\text{as left reading} = (\text{non-corrected reading} \cdot \text{new } PM) + \text{new } PA$$

- ⑩ If desired, verify the **as left** data by rerunning the calibration with the new *PA*(s) and *PM*(s) applied and checking that the disagreements between the calibration standard and the RPT readings are in tolerance.

⚠ Caution

- The value of *PA* must be entered in the pressure unit Pascal [Pa]. If your calibration data is in a unit other than Pascal, the calculated value of *PA* will be in the other unit and must be converted to Pascal before it is entered.
- If you are not familiar or comfortable with the mathematics for *PA* and *PM* manipulation, it is recommended you verify the as left readings as suggested in Step ⑩ above. This will provide practical confirmation of the integrity of the calculations. Note also that the CalTool for RPTs software delivered with the molbox RFM performs the necessary calculations automatically.

5.3 OHMIC Measurement System Verification

○ PURPOSE

To verify the measurements made by molbloc RFM's ohmic measurement system.

○ PRINCIPLE

molbox RFM includes an ohmic measurement system used to measure the resistance of the two Platinum Resistance Thermometers (PRTs) mounted in molbloccs. The temperature of the PRTs is calculated from the resistance. The molbloc PRTs have nominal resistance at 0 °C of 100 Ω and a slope of 0.3896 following DIN Norm 43760. The measured resistance at 0 °C for each PRT is stored on the molbloc EEPROM and read by the molbox RFM.

The ohmic measurement system self-calibrates using on-board 100 and 110 Ω reference resistors. On molbox RFM power up, an automated routine adjusts the ohmic measurement system relative to on-board, reference resistor readings. During this routine, "System autocal" is displayed on the molbox RFM display. The on-board reference resistors used to calibrate the molbox RFM measurement system have accuracy of ± 0.01 % and stability of ± 0.0025 % for one year, ± 0.005 % for three years.

The self-calibration feature and the very high accuracy and stability of the reference resistors relative to the accuracy tolerance on the molbox RFM temperature measurements make it unnecessary to calibrate

the ohmic measurement system independently. It is a good practice, however, to verify the ohmic measurement system. This is most easily accomplished globally by connecting a known resistance value to the measurement circuit where the molbloc PRTs are normally connected and verifying that the molbox RFM reads the correct corresponding temperature when that resistance is connected. Reference resistors mounted in a molbloc simulator for easy connection to molbox RFM using the normal molbloc connection cable can be purchased from your Fluke Calibration Sales Representative [molbloc simulators: 100 Ω (0°C nominal) P/N 3069694, 107 Ω (18°C nominal) P/N 3069682, 110 Ω (25°C nominal) P/N 3069701]. These are nominal resistors whose values are reported and can be measured independently if desired. The measured resistance of the reference resistors and a value for resistance at 0 °C of 100 Ω are programmed on the simulator EEPROM. Using these values,, if the molbox RFM ohmic measurement system and associated connections are working properly, when the simulator is connected the molbloc temperature indicated by molbox RFM should equal the reference temperature corresponding to the molbloc simulator reference resistor following:

$$\text{Reference temperature [}^{\circ}\text{C]} = \frac{\text{Reference resistor value } [\Omega] - 100}{0.3896}$$

The Reference temperature [°C] calculated from the actual reference resistor value is written on the molbloc simulator. The temperature value read by the molbox RFM when the molbloc simulator is connected can be observed by pressing [P&T] (see Section 3.4.5). The disagreement between the reference temperature and the molbloc indication should not exceed 0.05 °C.

Note

Because the ohmic measurement system is set up to measure two PRTs, there are two reference resistors in the molbloc simulator. Their resistance is not identical so there are actually two reference temperatures printed on the molbloc simulator and an average temperature which correspond to the three temperatures on the molbox RFM [P&T] temperature display (see Section 3.4.5).

○ OPERATION

To verify the molbox RFM ohmic measurement system proceed as follows:

- ❶ Connect a molbloc simulator to the molbox RFM and initialize it as if connecting a molbloc (see Section 2.3.3).
- ❷ Press [P&T] button twice to display the molbox RFM temperature measurement.
- ❸ Compare the three molbox RFM temperature measurements (upstream, downstream and average) to the calculated reference temperature values written on the molbloc simulator.
- ❹ If all disagreements between molbox RFM indications and corresponding calculated reference temperatures are less than 0.05 °C, the ohmic measurement system verification passed.

If any disagreement between a molbox RFM indication and the corresponding calculated reference temperature is greater than 0.05 °C, the ohmic measurement system verification failed.

Possible reasons for failure include:

- Faulty molbox RFM internal reference resistor(s)
- Faulty molbox RFM internal relays
- Faulty connections between molbox RFM and the molbloc simulator
- Faulty molbloc simulator

Check the molbox RFM to molbloc simulator connections and repeat the verification. If the out-of-tolerance condition persists, the molbox RFM and/or the molbloc simulator need service.

⚠ Caution

Pressing [SPECIAL] and selecting <4Cal>, <2temp> provides access to view and edit the value of molbox RFM's temperature adders and multipliers. Altering these values can cause out of tolerance flow readings. In normal circumstances, these values are only altered by the factory when a reference resistor is replaced and they should not be altered by the user.

5.3.1 OHMIC Measurement System Calibration/Adjustment Procedure

The standard calibration procedure requires at least two simulators and is performed as follows:

- ❶ Press [SPECIAL], <4cal>, <2temp> to read and record the current values of TA and TM, then exit to the main run screen.
- ❷ Press the [P&T] button twice to display the real time temperature readings.
- ❸ Connect a molbloc simulator to the molbox RFM and initialize it as if connecting a molbloc see Section 3.5.4).
- ❹ Record the average molbloc simulator calibrated temperature and the molbox RFM top row centered calibration temperature reading (the averaged temperature) for each temperature point into a spreadsheet. Repeat steps ❸ and ❹ for each simulator.

Calculate the "non-corrected" temperature readings by backing out the as received TA and TM recorded in Step ❶ above, following:

$$\text{non-corrected reading} = (\text{corrected reading} - \text{TA})/\text{TM}$$

- ❺ Perform a best fit linear regression to find the offset and slope that best fit the uncorrected temperature readings to the calibrated molbloc simulator temperatures. Most commercial spreadsheet products have a standard function to perform a linear regression. The offset, in the current temperature unit, is the new value of TA, the slope is the new value of TM.
- ❻ Press [SPECIAL], <4cal>, <2temp> to write the new values of TA (in the current unit of measure) and TM and the new calibration date (YYYYMMDD).
- ❼ Calculate "as left data" for the calibration:
$$\text{as left reading} = (\text{non-corrected reading} \cdot \text{new TM}) + \text{new TA}$$
- ❽ If desired, verify the as left data by rerunning the calibration with the new TA and TM applied and checking that the disagreements between the molbloc simulators and the molbox RFM temperature readings are in tolerance.

⚠ Caution

- **The value of TA must be entered in the current unit of measure, either °C or °F, that is displayed by the molbox RFM.**
- **If you are not familiar or comfortable with the mathematics used for TA and TM manipulation, it is recommended you verify the as left readings as suggested in Step 8) above to provide practical confirmation of the integrity of the calculations.**
- **If an out-of-tolerance condition persists, the molbox RFM and/or the molbloc simulator(s) may need service.**

5.4 Reloading Embedded Software Into molbox RFM Flash Memory

molbox RFM uses FLASH memory. This allows the embedded software that controls molbox RFM operations and functions to be loaded into molbox RFM over its COM1 port from a personal computer with a simple FLASH loading utility.

To replace corrupted software or upgrade to a new version, your Fluke Calibration Authorized Service Provider can provide a FLASH memory loading utility along with a file containing the molbox RFM embedded software. These are also available for download from Fluke Calibration's worldwide web site, www.flukecal.com.

If the embedded software you are using is suspected of a problem, record all symptoms and contact your Fluke Calibration Authorized Service Provider.

Note

The Fluke Calibration flash software loading utility and molbox RFM embedded software are available for download from the "SOFTWARE" section of Fluke Calibration's worldwide web site at www.flukecal.com.

5.5 RELOADING MOLBLOC EEPROM FILE

molbloc EEPROMs are programmed with:

- A molbloc identifying header with range identifier, S/N and calibration date.
- molbloc specific flow calibration coefficients for N₂, and other gases if entered.
- The resistance at 0 °C of the molbloc PRTs.

If the molbloc EEPROM information becomes corrupted, molbox RFM will be unable to read the molbloc EEPROM and will display **<NO BLOC>** when attempting to initialize the molbloc. Note that **<NO BLOC>** error may also be displayed if a new molbloc element produced with molbox1+ calibration data structure is connected to a molbox RFM that does not have embedded firmware version 1.20 or higher. Contact your Fluke Calibration Authorized Service Provider for more information.

Fluke Calibration maintains files of the "as shipped" EEPROM contents of every molbloc delivered. A molbloc EEPROM loading tool may be downloaded from the Fluke Calibration worldwide web site (www.flukecal.com) and specific molbloc files can be obtained by email. If you believe you have a molbloc with a corrupted EEPROM, contact your Fluke Calibration Authorized Service Provider for additional information on the molbloc EEPROM loading tool and obtaining molbloc data files.

5.6 Overhaul

Caution

If calibration of the Reference Pressure Transducers (RPTs) is included as part of the overhaul procedure, the calibration procedure should be performed last as other overhaul procedures may affect RPT calibration.

Any or all of the following items may be included as part of a system maintenance overhaul:

- Clean front panel.
- Check that top cover mounted cooling fan operates when molbox RFM is powered.

Note

To open the molbox RFM case, remove the pop-off screw covers on the top of the case. Then remove the four case screws. Lift OFF the cover taking care NOT to damage the electrical leads that connect the molbox RFM main board to the cover mounted cooling fan. Disconnect the cooling fan at the main board terminal to completely remove the cover. Reconnect when reassembling.

- Disassemble valving assembly and clean valve components.
- Check that internal screws, bolts and nuts are tight.
- Perform molbox leak check (see Section 3.4.4.3.1) and verify operation by connecting a molbloc (see Section 2.3.3).
- Perform calibration of RPTs, if necessary (see Section 5.2).
- Verify ohmic measurement circuit, if necessary (see Section 5.3).

5.6.1 Internal View

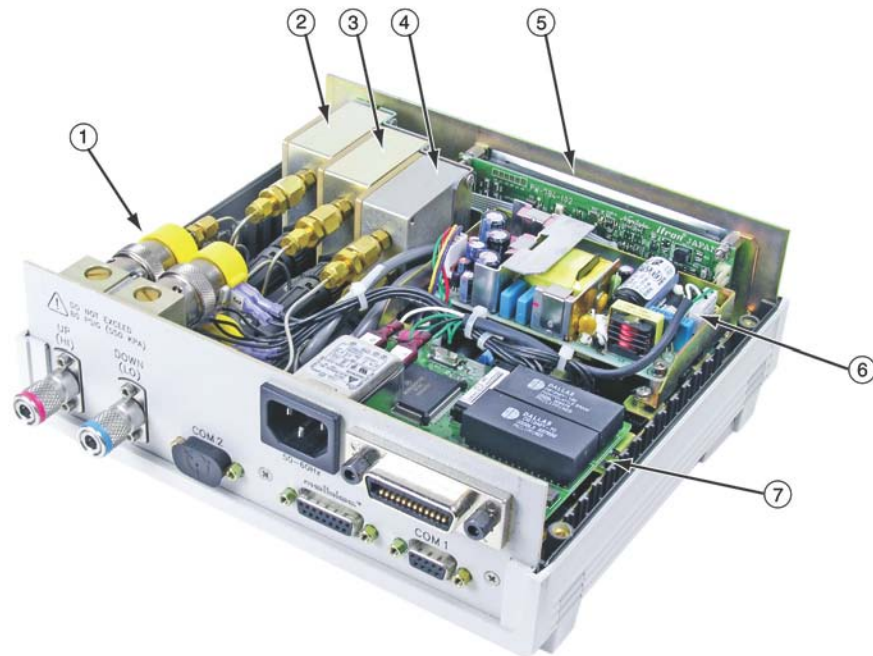

- ① Valving assembly
- ② Upstream (HI) absolute reference pressure transducer (RPT)
- ③ Downstream (LO) absolute reference pressure transducer (RPT)
- ④ Optional microrange differential reference pressure transducer (RPT), not present if microrange option not included (see Section 3.1.5)
- ⑤ Display
- ⑥ Power supply
- ⑦ Micro board
- ⑧ Main board (not visible, under micro board and power supply)
- ⑨ Cooling fan (not visible, mounted on top cover)

Figure 17. molbox RFM Internal View

5.6.1.1 Upstream absolute RPT

Measures absolute pressure on the UP (HI) molbloc pressure connection port. Connected pneumatically to the valving assembly and electrically to the main board (COM4) (see Section 5.6.1.8).

5.6.1.2 Downstream absolute RPT

Measures absolute pressure on the DOWN (LO) molbloc pressure connection port. Connected pneumatically to the valving assembly and electrically to the main board (COM5) (see Section 5.6.1.8)

5.6.1.3 Differential microrange RPT (optional)

Measures differential pressure between the UP (HI) and DOWN (LO) molbloc pressure connection ports (upstream (+), downstream (-)). Connected pneumatically (x2) to the valving assembly and electrically to the main board (COM6) (see Section 5.6.1.8).

5.6.1.4 Display

2 x 20 vacuum fluorescent, alpha-numeric display mounted to front panel.

5.6.1.5 Power Supply

molbox RFM has one power supply with two voltage outputs:

- V DC ($\pm 5\%$) @ 0.9 Amps: for valve excitation, RPT supply and analog circuit.
- V DC ($\pm 5\%$) @ 2.5 Amps: for micro board, main board, display and fan.

5.6.1.6 Micro Board

The micro board supports a Motorola 68302 micro-controller, EPROM, EEPROM, 128k x 16 bit NVRAM, 8 Mbit flash memory; RS232 and IEEE-488.2 communications; keypad and display control. An I/O port controls other ports and devices within molbox RFM.

5.6.1.7 Valving Module

The valving module (see Figure 17) consists of a manifold equipped with three 12 V, 2-way, solenoid valves. The valves connect and disconnect the RPTs to the UP (HI) and DOWN (LO) rear panel ports and bypass the two ports together. If molbox RFM is equipped with the microrange option, a fourth (3-way) solenoid valve puts the microrange differential RPT into and out of service (bypassed or not bypassed).

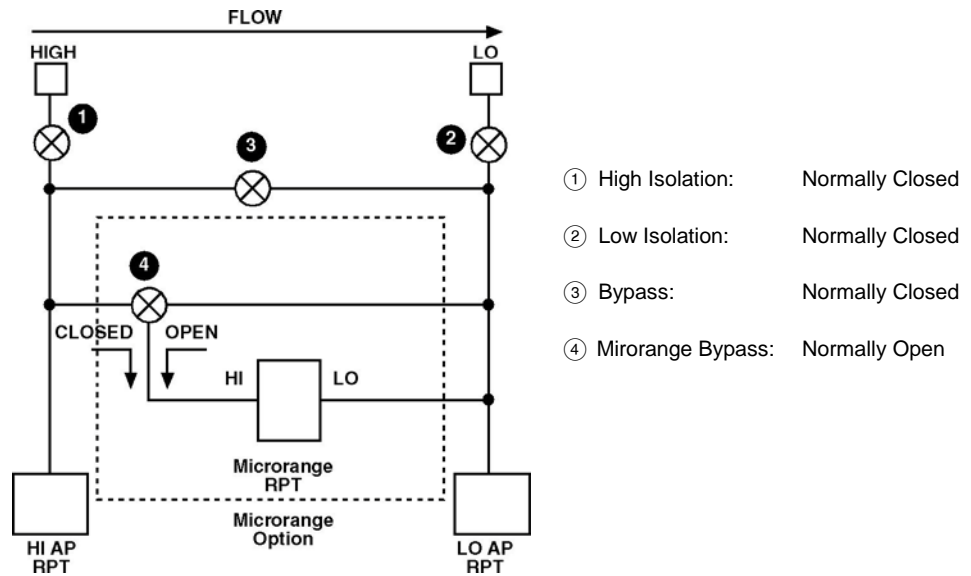

Figure 18. molbox RFM Valving Assembly Schematic

5.6.1.8 Main Board

The main board is controlled by the micro board (see Section 5.6.1.6). The main board supports the 12 V drivers for the valving assembly solenoid excitation, the ohmic measurement system and the beeper. The main board also includes COM ports for reading RPTs.

5.6.1.9 Cooling fan

The cooling fan is mounted to the molbox RFM top cover and connected to the main board. It is a 5 V brushless DC fan, max. air flow 0.13 m³m (4.6 cfm).

6. Troubleshooting

6.1 OVERVIEW

molbox RFM is a sophisticated flow measuring instrument with advanced on-board features and functions. Before assuming that unexpected behavior is caused by a system defect or breakdown, the operator should use this manual and other training facilities to become thoroughly familiar with molbox RFM operation. This troubleshooting guide is intended as an aid in identifying the cause of unexpected molbox RFM behavior and determining whether the behavior is due to normal operation or an internal or external problem.

Identify the symptom or unexpected behavior you are observing from the **SYMPTOM** list below. A **PROBABLE CAUSE** is provided and a **SOLUTION** is proposed including references to manual sections that provide information that may be of assistance.

Table 43. Troubleshooting Checklist

SYMPTOM	PROBABLE CAUSE	SOLUTION
Will NOT power up.	Blown fuse.	Replace fuse.
Front panel keys seem to be disabled.	"Remote" command has been sent from a host computer.	Send "local" command from host computer or cycle molbox RFM power. (4.2)
Front panel display is dim.	Screen saver option has activated.	Press any key to resume full screen power, adjust activation time if desired. (3.4.5.1)
Keypad presses make undesired sounds or no sounds.	Keypad sound settings are incorrect.	Use SOUNDS function to set keypad sounds as desired. (3.4.5.2)
Cannot access certain functions. Display shows: <ACCESS RESTRICTED>.	User level setting restricts access to that function.	Change user level or consult system manager. (3.6.2)
Cannot establish communication over remote interface.	Computer and/or molbox RFM interface not correctly configured; incorrect or bad interface cable.	Check and correct interface configurations and cables if necessary. Run COM port test. (3.6.6.3.)
molbox RFM unable to read molbloc.	Cable not connected, molbloc data corrupted.	Check cable connections, try another molbloc, reload molbloc EEPROM. (3.3.8 and 5.5)
Displays <FATAL ERROR> or <FATAL FAULT>.	Encountered unresolved internal software conflict.	Cycle power to clear. Please record conditions leading up to event including the numbers displayed when [ENTER] is pressed and report to Fluke Calibration Authorized Service Provider.
Displays <PRT ERROR>.	molbox RFM has identified an unusually large disagreement between the temperature readings of the two molbloc PRTs which may be due to faulty molbloc PRTs or the molbox RFM ohmic measurement system.	Connect a different molbloc. If the PRT error is no longer present, the PRT system of the original molbloc is probably damaged and requires service. If the PRT error is present with different molblobs, the molbloc/molbox cable or RFM ohmic measurement system is probably defective and requires services.
Display <TOUT> or <TIME-OUT>.	molbox RFM is having an internal communications problem with one or several of its RPTs.	Turn power off and back on and or execute Reset - Sets being careful to reenter desired settings afterwards. If problem persists, molbox RFM needs service. (3.6.1.1)

Table 43. Troubleshooting Checklist (Continued)

SYMPTOM	PROBABLE CAUSE	SOLUTION
Displays <NO BLOC>.	No molbloc is connected to molbox RFM or molbox RFM is unable to read the molbloc that is connected.	Verify proper electrical connection between the molbox RFM and a valid molbloc. If <NO BLOC> is observed with one molbloc and not others, molbloc is damaged and/or EEPROM is corrupted. (5.5)
Displays <*****> where a numerical value should go.	Number to be displayed is too large for allocated space. Usually due to an erroneous setting or measurement causing an out of limit value to be calculated.	Check settings that may be causing an out of limit measurement and adjust if necessary. (3.4.5, 3.4.1, 3.5.6)
Bottom line of display has changed and you want to change it back.	The DISPLAY function has been used to change the display.	Use [DISPLAY] to set bottom line to desired display. (3.4.6)
Bottom line of display is blank.	DISPLAY mode is "clean".	Operation is normal. Use [DISPLAY] to change bottom line display if desired. (3.4.6.6 and 3.4.6)
Display is showing pressure values and flashing, beeper is sounding two second beeps.	Pressure applied to one or both of the absolute RPTs is near overpressure.	Reduce pressure applied to upstream (HI) and downstream (LO) molbloc pressure connection ports. (3.6.3)
Display is showing <OVERP!>.	One or both of the molbox absolute RPTs has been overpressured.	Remove the source of overpressure and press [ENTER] to clear. Check molbox RPTs for damage. (3.6.3)
Display is showing <BPR HI> where the flow value should go.	molbox RFM is connected to a molbloc-S and the ratio of downstream pressure to upstream pressure (B\PR) is too high to make a valid flow measurement.	Operation is normal. Increase flow to increase upstream pressure and/or decrease downstream pressure. 3.1.2, 3.6.9
Flow indicated by molbox RFM never becomes stable.	The flow through the molbloc is not stable.	molbox RFM passively measures the flow through the molbloc. It does not control flow. Correct conditions that are causing unstable flow.
A Ready (<*>) indication is never achieved during molbloc-L operation.	Flow stability criterion is never being met.	Adjust stability criterion or stabilize flow. (3.5.5, 3.1.3)
Ready (<*>) indication does not seem to be based on current stability setting.	The flow is within the stability limit but the Reynolds number of the flow exceeds the maximum acceptable limit of 1 200.	Operation is normal. (3.5.5, 3.1.3)
Flow indication is flashing during molbloc-L operation	Reynolds number is greater than 1300	Operation is normal. Indicates that flow is beyond the molbloc-L range (1.2.4.1.3, 1.2.4.1.4, 3.2.1, 3.1.3)
Flow indication is flashing in molbloc-L mode	Flow is 5% or more beyond the maximum flow for a named cal molbloc gas calibration.	Operation is normal. Indicates that flow is beyond the molbloc-L calibrated range 1.2.5.1.2, 1.2.5.1.3, 3.2
Flow indication is flashing in molbloc-L mode	Pressure is 10kPa above the maximum pressure or 10kPa below the minimum pressure for a named cal molbloc gas calibration.	Operation is normal. Indicates that flow is beyond the molbloc-L calibrated range 1.2.5.1.2, 1.2.5.1.3, 3.2
Flow indication is flashing in molbloc-S mode	Flow is 5% or more beyond the maximum flow for a named cal molbloc gas calibration.	Operation is normal. Indicates that flow is beyond the molbloc-S calibrated range 1.2.5.1.2, 1.2.5.1.3, 3.2
Flow indication is flashing in molbloc-S mode	Pressure is 10kPa above the maximum pressure or 10kPa below the minimum pressure for a named cal molbloc gas calibration.	Operation is normal. Indicates that flow is beyond the molbloc-S calibrated range 1.2.5.1.2, 1.2.5.1.3, 3.2

Table 43. Troubleshooting Checklist (Continued)

SYMPTOM	PROBABLE CAUSE	SOLUTION
Flow indication is flashing during molbloc-S operation	Back pressure ratio is too high to establish critical flow through the molbloc-S.	Operation is normal. Increase molbloc-S upstream pressure or reduce downstream pressure to reduce BPR below the BPR limit at the current Reynolds numbers. 3.1.2, 1.2.4.2.1.
Pressure indicated by molbox RFM never becomes stable.	There is a leak in the molbox RFM and/or in the system to which it and the molbloc are connected.	Find and correct leak. Consider using molbox RFM LEAK CHECK functions. (3.4.4.3)
Flow indication appears to be grossly incorrect.	Your assumption of flow in the system is grossly incorrect.	Check and adjust flow in the system.
Flow indication appears to be grossly incorrect.	The molbloc connected to molbox RFM has been swapped without reinitialization so molbox RFM is still using characteristics from a previous molbloc.	Reinitialize molbloc using [molbloc] . (3.4.8)
During molbloc-S operation, there is no flow through the molbloc but molbox RFM is indicating a large flow value.	molbox RFM is in BPR OFF mode and flow is being calculated from upstream absolute pressure without knowledge of downstream pressure.	Behavior is normal. Consider BPR when evaluating flow measurements when using molbloc-S. Also consider changing BPR mode to Auto or ON. 3.1.2, 3.6.9, 3.4.4.5
Flow indication appears to be incorrect.	molbox/molbloc and/or the device you are comparing it to are in tolerance but you have not properly evaluated the tolerance limits.	Determine flow measurement tolerance of molbloc/molbox and device you are comparing with. Evaluate "correctness" relative to the combined tolerance of the two. (1.2.4)
Flow indication appears to be incorrect.	Reference pressure transducer(s) (RPT) are inoperable or out of calibration.	Use [P&T] to view pressure indications. Recalibrate RPTs if necessary. (3.4.5 and 5.2)
Flow indication appears to be incorrect.	The gas selected is not the gas flowing through the molbloc.	Select the correct gas. (3.4.2)
Flow indication appears to be incorrect while using molbloc-S to measure air flow	Incorrect humidity ratio is being used.	Reselect Air as the test gas and make sure the humidity ratio W is entered properly. W should be zero for dry air and should be calculated from ambient conditions when measuring ambient air. 3.4.2.2.
Flow indication appears to be incorrect.	The gas selected is the gas flowing through the molbloc but the molbloc has not been calibrated for that gas.	Verify that the molbloc has calibration coefficients for the flowing gas, have the molbloc calibrated for the flowing gas if necessary or accept lower accuracy flow measurements. (1.2.4)
Flow indication appears to be incorrect.	Gas flowing through molbloc is not pure.	Check purity rating of gas used; purge molbox/molbloc if flowing gas was just changed. If gas is a known mix, use the flow <i>adder</i> and <i>multiplier</i> to correct for the mix. (3.4.4.2, 3.5.6)
Flow indication appears to be incorrect.	The molbloc is not being used at the correct pressure for its pressure dependent calibration type.	Check molbloc calibration certificate for pressure dependent calibration type and check operating pressure. (1.2.4 and 3.4.5)
Flow indication appears to be incorrect.	molbox RFM pressure and/or Reynolds numbers are outside of limits.	Observe pressure and Reynolds numbers and adjust pressure/flow to be inside of limits. (1.2.4 and 3.4.5)
Flow indication appears to be incorrect.	Flow through molbloc is in wrong direction.	Check that flow through molbloc is in direction of arrow on molbloc. Switch if necessary.

Table 43. Troubleshooting Checklist (Continued)

SYMPTOM	PROBABLE CAUSE	SOLUTION
Flow indication appears to be incorrect.	Leak in pressure lines from molbloc to molbox RFM.	Check lines for leaks and correct if necessary. (3.4.4.3)
Flow indication appears to be incorrect.	A flow <i>adder/multiplier</i> has been incorrectly or inadvertently applied.	Check and correct if necessary. (3.5.6)
Flow indication appears to be incorrect.	molbloc calibration has changed due to contamination.	Check molbloc for contamination. Contact your Fluke Calibration Authorized Service Provider if liquid or particulate contamination is detected.
Flow indication appears to be incorrect in the low end of the range.	molbox RFM is equipped with microrange but the option is not on.	Turn on microrange option. (3.4.7)
Flow indication appears to be incorrect by a constant offset amount.	molbox RFM needs to be correctly "zeroed" (<i>tared</i>) at the current operating pressure.	<i>Tare</i> molbox RFM. Be sure to <i>tare</i> "upstream" if the upstream pressure is constant and downstream if the downstream pressure is constant. (3.4.4.1)
Flow indication appears to be incorrect and molbloc is upstream and reading high.	Leak downstream of molbloc.	Check for and correct leak if present. Consider using molbox RFM SYSTEM LEAK CHECK function. (3.4.4.3.2, Leak Check System)
Flow indication appears to be incorrect and flow rate is less than 50 sccm.	Flow in system is not in steady state; too much volume between molbloc and test; unstable pressure on molbloc.	Be sure flow is stable before reading, reduce dead volumes, install precision regulator.
Unable to make molbloc-S flow measurements over full expected flow range.	MFC or flow control valve is connected downstream of molbloc-S.	Valve or regulator used to control flow through molbloc-S must always be upstream of the molbloc-S. When operating an MFC with molbloc-S, the MFC must always be upstream (3.1.2)
unable to make molbloc-s flow measurements over full expected flow range.	molbloc-S back pressure too high	The downstream pressure on molbloc-S must always be significantly lower than the upstream pressure to maintain critical flow. When upstream pressure is reduced, the back pressure ratio may become too high to make valid flow measurements. (3.1.2)
Unable to make molbloc-S flow measurements over full expected flow ranges.	Flow units use reference temperature other than 0° C.	The molbloc-S flow range table displays flow ranges expressed in slm @ 0° C. If you use volumetrically based flow units with another reference temperature, the minimum usable flow value may be increased by up to 9% for a given molbloc-S upstream pressure. (1.2.4.2.1, 3.4.3.3)
Unable to reach molbloc-S maximum flow	Pressure regulator supplying molbloc-S set too low.	If you are controlling flow with a control valve downstream of a fixed pressure regulator, you must have sufficient supply pressure to reach the maximum desired molbloc-S flow. Be sure not to exceed molbox RFM maximum operating pressure. (2.3.4, 3.6.3)
Flow indication appears to be incorrect and flow unit is a volumetrically based mass flow unit (sccm, scfh, etc.).	Reference temperature or compressibility consideration in volumetrically based units is inconsistent.	Set units correctly for consistency between values being compared. Be sure to select a unit starting in "u" for volumetrically based mass flow units if reference temperature is not 0 °C. (3.4.3)
Flow indication appears to be incorrect and there is a K following the flow unit on the display.	A K factor is being applied incorrectly or inadvertently.	Turn off or correct K factor. (3.4.1)

Table 43. Troubleshooting Checklist (Continued)

SYMPTOM	PROBABLE CAUSE	SOLUTION
Flow indication appears to be incorrect and you are using AVERAGING function.	Averaging period is wrong and does not correspond to reading period of the device you are comparing with.	Adjust averaging period and/or be sure to synchronize averaging period of the molbox RFM and the device you are comparing to. (3.4.6.2)
Flow indication is negative.	Flow in your system is reverse from what you expect; molbloc upstream and downstream pressure lines are switched.	Check system and correct flow; check pressure lines and switch if necessary.
Pressure transducer (RPT) indications are out of range.	Incorrect RPT calibration coefficients; RPT(s) has (have) been overpressured.	Correct calibration coefficients; have transducers replaced if damaged. (5.2)
molbloc-S Tare does not execute as expected	Expectation of tare function operation is incorrect for molbloc-S.	Normal molbox RFM operation. The molbloc-S tare function has a different purpose and method of operation from molbloc-L tare and does not require saving a fixed tare value. 3.4.4.1.2
Cannot tare molbox due to excessive tare value.	One or several RPTs are defective; RPT calibration is bad; there is a leak inside molbox RFM causing a differential pressure.	Check performance of RPTs; check calibration of RPTs; leak check molbox RFM. (5.2 and 3.2.4.3.1)
Leak check does not indicate pass/fail in molbloc-S operation.	Improper expectation for molbloc-S leak check.	Normal molbox RFM operation. molbloc-S system leak check function in molbox RFM does not have pass/fail criteria assigned as molbloc-L leak check does. (3.4.4.3.2)
Measured pressure display has too much/not enough resolution.	Resolution setting needs to be changed.	Use [RES] to change resolution setting. (3.4.9)
Resolution is greater than the resolution set by [RES] and/or resolution is changing in the lower part of the molbloc range.	molbox RFM has the microrange option and the option is ON which causes resolution to increase by a factor of 10 when the differential pressure across the molbloc is < 12.5 kPa (1.8 psi).	Operation is normal if microrange is on. Change resolution setting and/or turn microrange off if desired. (3.4.9 and 3.4.7)
Flow rate is changing but display of flow is not and the bottom right hand corner of the display is a numerical countdown followed by <avg>.	AVERAGE DISPLAY function is ON and pressure display is updating only with the average value at the end of each averaging cycle.	Go to a DISPLAY function other than AVERAGE or press [+/-] to get the instantaneous value AVERAGE DISPLAY. (3.4.6.2)
Current flow through molbloc-L is zero but reading is not zero.	Need to run TARE function to zero molbox RFM RPTs.	Run TARE. (3.4.4.1)
Poor flow measurement characterized by instability and sudden small jumps in flow rate.	The molbox RFM pneumatic circuit is contaminated with liquids.	Purge and clean molbox RFM and associated pneumatic systems. Contact your Fluke Calibration Authorized Service Provider.
Grossly inaccurate flow measurements and little or no response to pressure or flow changes.	RPT(s) destroyed by overpressure.	View pressure readings using [P&T]. If readings are grossly inaccurate and don't respond to pressure changes, contact your Fluke Calibration Authorized Service Provider. (3.4.5, 3.1.6.2, 3.6.7)
Apparent inaccurate pressure measurement.	Incorrect pressure units.	Set desired pressure units. Consider reference temperature if unit is inW/a. (3.5.2)
Apparent inaccurate pressure or flow measurement.	Reference pressure transducer (RPT) calibration coefficients have been altered or lost and pressure measurements are incorrect.	Check and correct calibration coefficients if needed. (5.2)

Notes

7. Appendix

7.1 CONVERSION OF NUMERICAL VALUES

molbox RFM performs all internal calculations in SI units. Numerical values input or output in other units are converted to SI immediately after entry and back to other units just before output as needed.

The tables below provide the conversion coefficients used by molbox RFM to convert numerical values expressed in SI units to corresponding values expressed in other units.

7.1.1 PRESSURE

Table 44. Pressure Unit Conversions

TO CONVERT FROM PA TO		MULTIPLY BY
Pa	Pascal	1.0
mbar	millibar	1.0 E-02
kPa	kilo Pascal	1.0 E-03
bar	bar	1.0 E-05
mmWa @ 4 °C	millimeter of water	1.019716 E-01
mmHg @ 0 °C	millimeter of mercury	7.50063 E-03
psi	pound per square inch	1.450377 E-04
psf	pound per square foot	1.007206 E-06
inWa @ 4 °C	inch of water	4.014649 E-03
inWa @ 20 °C	inch of water	4.021732 E-03
inWa @ 60 °F	inch of water	4.018429 E-03
inHg @ 0 °C	inch of mercury	2.953 E-04
kcm ²	kilogram force per centimeter square	1.019716 E-05
user	user	User defined coefficient

7.1.2 Temperature

Table 45. Temperature Unit Conversion

TO CONVERT FROM °C TO	MULTIPLY BY
°F	9/5 and add 32

7.1.3 Flow

Table 46. Conversions From kg/s To sccm At 0 °C For Various Gases

TO CONVERT FROM KG/S TO SCCM AT 0 °C	MULTIPLY BY
Air (Air)	4.64109 E+07
Argon (Ar)	3.36398 E+07
Butane (C ₄ H ₁₀)	2.22112 E+07
Carbon Dioxide (CO ₂)	3.03490 E+07
Carbon Monoxide (CO)	4.79862 E+07
Carbon Tetrafluoride (CF ₄)	1.52386 E+07
Ethane (C ₂ H ₆)	4.42602 E+07
Ethylene (C ₂ H ₄)	4.75813 E+07
Fluoroform (CHF ₃)	1.90128 E+07
Helium (He)	3.36210 E+08
Hexafluoroethane (C ₂ F ₆)	9.60432 E+06
Hydrogen (H ₂)	6.67483 E+08
Methane (CH ₄)	8.36354 E+07
Nitrogen (N ₂)	4.79808 E+07
Nitrous Oxide (N ₂ O)	3.03321 E+07
Oxygen (O ₂)	4.19903 E+07
Propane (C ₃ H ₈)	2.98516 E+07
Sulfur Hexafluoride (SF ₆)	9.06602 E+06
Xenon (Xe)	1.01710 E+07

Table 47. Conversions From sccm At 0 °C To Other Volumetrically Based Flow Units

TO CONVERT FROM SCCM AT 0 °C TO OTHER VOLUMETRICALLY BASED UNITS	MULTIPLY BY
slm	1.0 E-03
slh	6.0 E-02
scfm	3.53147 E-05
scfh	2.11888 E-03
sm ³ m	1.0 E-04
sm ³ h	6.0 E-05

Table 48. Conversions From Volumetrically Based Flow Units At 0 °C To Corresponding Units At Another Temperature (uxxx)

TO CONVERT VOLUMETRICALLY BASED UNITS AT 0 °C TO CORRESPONDING UNITS AT ANOTHER TEMPERATURE, θ , (UXXX)	MULTIPLY BY
sccm slm slh scfm scfh sm3m sm3h	$\frac{(T_N + \theta) Z_{(P_N, (T_N + \theta))}}{T_N \cdot Z_N}$

Where: θ = Alternate reference flow temperature [°C].

$Z_{(P_N, (T_N + \theta))}; Z_N$ gas dependent compressibility factors

Table 49. Conversions From kg/s To mole/s For Various Gases

TO CONVERT KG/SEC TO MOLE/S	MULTIPLY BY
Air (Air)	3.45316 E+01
Argon (Ar)	2.50325 E+01
Butane (C ₄ H ₁₀)	1.72049 E+01
Carbon Dioxide (CO ₂)	2.27221 E+01
Carbon Monoxide (CO)	3.57015 E+01
Carbon Tetrafluoride (CF ₄)	1.13624 E+01
Ethane (C ₂ H ₆)	3.32568 E+01
Ethylene (C ₂ H ₄)	3.56455 E+01
Fluoroform (CHF ₃)	1.42837 E+01
Helium (He)	2.49838 E+02
Hexafluoroethane (C ₂ F ₆)	7.24533 E+00
Hydrogen (H ₂)	4.96032 E+02
Methane (CH ₄)	6.23325 E+01
Nitrogen (N ₂)	3.56939 E+01
Nitrus Oxide (N ₂ O)	2.27206 E+01
Oxygen (O ₂)	3.12512 E+01
Propane (C ₃ H ₈)	2.26778 E+01
Sulfur Hexafluoride (SF ₆)	6.84697 E+00
Xenon (Xe)	7.61615 E+00

Table 50. Conversion From mole/s To pccm

TO CONVERT MOLE/SEC TO PCCM	MULTIPLY BY
ANY GAS	1.34483 E+06

Note

The “p” in pccm indicates “perfect” in which a gas compressibility factor of 1 is assumed for all gases. In early 1996, SEMI, a semiconductor industry group, adopted standard E12-96 which specified that this definition be used for volumetrically base mass flow units.

Table 51. Conversion From sccm At 0 °C to Volume Flow Units At Another Pressure And Temperature

TO CONVERT FROM A VOLUMETRIC MASS FLOW UNIT TO THE EQUIVALENT VOLUME FLOW UNIT AT TEMPERATURE θ AND P_{USER}	MULTIPLY BY
sccm to ccm slm to lm slh to lh scfm to cfm scfh to cfh sm3m to m3m sm3h to m3h	<input style="width: 150px; height: 30px;" type="text"/>

Where:

P_{user} = user pressure [kPa]

θ = user temperature [°C]

= gas dependent compressibility factors

7.2 Limited Warranty and Limitation of Liability

Each Fluke product is warranted to be free from defects in material and workmanship under normal use and service. The warranty period is one year and begins on the date of shipment. Parts, product repairs and services are warranted for 90 days. This warranty extends only to the original buyer or end-user customer of a Fluke authorized reseller, and does not apply to fuses, disposable batteries or to any product which, in Fluke's opinion, has been misused, altered, neglected, contaminated, or damaged by accident or abnormal conditions of operation or handling. Fluke warrants that software will operate substantially in accordance with its functional specifications for 90 days and that it has been properly recorded on non-defective media. Fluke does not warrant that software will be error free or operate without interruption.

Fluke authorized resellers shall extend this warranty on new and unused products to end-user customers only but have no authority to extend a greater or different warranty on behalf of Fluke. Warranty support is available only if product is purchased through a Fluke authorized sales outlet or Buyer has paid the applicable international price. Fluke reserves the right to invoice Buyer for importation costs of repair/replacement parts when product purchased in one country is submitted for repair in another country.

Fluke's warranty obligation is limited, at Fluke's option, to refund of the purchase price, free of charge repair, or replacement of a defective product which is returned to a Fluke authorized service center within the warranty period.

To obtain warranty service, contact your nearest Fluke authorized service center to obtain return authorization information, then send the product to that service center, with a description of the difficulty, postage and insurance prepaid (FOB Destination). Fluke assumes no risk for damage in transit. Following warranty repair, the product will be returned to Buyer, transportation prepaid (FOB Destination). If Fluke determines that failure was caused by neglect, misuse, contamination, alteration, accident or abnormal condition of operation or handling, including overvoltage failures caused by use outside the product's specified rating, or normal wear and tear of mechanical components, Fluke will provide an estimate of repair costs and obtain authorization before commencing the work. Following repair, the product will be returned to the Buyer transportation prepaid and the Buyer will be billed for the repair and return transportation charges (FOB Shipping Point).

THIS WARRANTY IS BUYER'S SOLE AND EXCLUSIVE REMEDY AND IS IN LIEU OF ALL OTHER WARRANTIES, EXPRESS OR IMPLIED, INCLUDING BUT NOT LIMITED TO ANY IMPLIED WARRANTY OF MERCHANTABILITY OR FITNESS FOR A PARTICULAR PURPOSE. FLUKE SHALL NOT BE LIABLE FOR ANY SPECIAL, INDIRECT, INCIDENTAL OR CONSEQUENTIAL DAMAGES OR LOSSES, INCLUDING LOSS OF DATA, ARISING FROM ANY CAUSE OR THEORY.

Since some countries or states do not allow limitation of the term of an implied warranty, or exclusion or limitation of incidental or consequential damages, the limitations and exclusions of this warranty may not apply to every buyer. If any provision of this Warranty is held invalid or unenforceable by a court or other decision-maker of competent jurisdiction, such holding will not affect the validity or enforceability of any other provision.

Fluke Corporation
P.O. Box 9090
Everett, WA 98206-9090
U.S.A.

Fluke Europe B.V.
P.O. Box 1186
5602 BD Eindhoven
The Netherlands

Table 52. Fluke Calibration Authorized Service Providers

COMPANY	TELEPHONE, FAX AND EMAIL	NORMAL SUPPORT REGION
Fluke Calibration US Customer Service (Regional)	Tel: 1-877-355-3225 service@flukecal.com	North America
Fluke Do Brazil (Brazil)	Tel: (11) 3759-7600 Fax: (11) 3759-7630 info@fluke.com.br	South America
Minerva Meettechnik BV	Tel: +31/33.46.22.000 info@minervaipm.com	Europe, Middle East, Africa
europascal GmbH	Tel: +49 61 81 42 309 0 Fax: +49 61 81 42 309 22 service@europascal.de	Germany, Austria, and Switzerland
Ohte Giken Inc. Technology Center	Tel: 81/29.840.9111 Fax: 81/29.840.9100 tech@ohtegiken.co.jp	Japan
Fluke South East Asia PTE LTD	Tel: 65 6799-5588 Fax: 65 6799-5589 service.asean@fluke.com	Southeast Asia
Fluke Int'l Corporation	Tel: +86-10-400-810-3435, Ext 2 serviceinfo@fluke.com.cn	Peoples Republic of China
Fluke Australia Pty LTD	Tel: +61-2-9771-9300 sales@fluke.com.au	Pacific Rim

8. Glossary

Absolute	As in “absolute pressure”. Pressure expressed relative to vacuum.
BPR	Back Pressure Ratio. The ratio of the downstream pressure to the upstream pressure on a molbloc-S critical flow based molbloc element. The BPR is used to determine whether Critical Flow conditions exist so that molbloc-S flow measurements are valid.
Critical flow	Also known as “sonic flow”. Flow regime where the speed of gas is accelerated to a velocity equal to the speed of sound under current conditions and the flow rate can be predicted by measurement of the upstream pressure at the flow restriction (nozzle), the gas pressure and temperature conditions and the gas properties.
Clean	A DISPLAY function in which the second line of the display is blank (clean).
Deviation	A DISPLAY function in which the deviation from a target flow value is calculated and displayed. The value of the difference between the target and the current flow reading.
Differential	As in “differential pressure”. Pressure expressed relative to a value other than vacuum or atmospheric pressure (see absolute and gauge). Frequently refers to the pressure drop across the molbloc.
Downstream	Location of point A relative to point B in a flow system in which point A is at a different location in the direction of the flow. For example, the downstream molbloc pressure port is downstream relative to the upstream pressure port because it is at a different location from the upstream port in the direction of the flow.
DUT	Device Under Test. The device being tested or calibrated.
FA (Flow Adder)	Flow <i>adder</i> . A value that is added to the measured flow to offset the measured flow value.
FM (Flow Multiplier)	Flow multiplier. A value by which the measured flow is multiplied to change the slope of the measured flow.
Freeze	A DISPLAY function in which the current flow reading can be captured and displayed by pressing [ENTER].
Full Mod Calibration	A molbloc calibration option which is valid over a range of operating pressure.
FS	Abbreviation of “full scale”. The full scale value is the maximum value or the span of a measurement range. Limits and specifications are often expressed as % FS.
Gauge	As in “gauge pressure”. Pressure expressed relative to atmospheric pressure.
Head	The differential pressure developed by differences in height between two points within a fluid medium.
Hi/Lo	A DISPLAY function in which the highest and lowest flow observed since hi/lo reset are recorded and displayed.
K Factor	A factor representing the relationship between the process gas and a surrogate gas for a DUT.
Microrange	An optional molbox RFM feature which improves flow measurement resolution and accuracy under 10 % of FS of the molbloc. Includes a low differential RPT and valve to put the RPT into and out of service.
Operating Pressure	The average pressure at which the molbloc is operated (average of upstream and downstream pressure) or, if the molbloc pressure is held constant by an upstream or downstream regulator, the value of the constant pressure.
PA (Pressure Adder)	Pressure <i>adder</i> , used in calibration adjustment to offset an RPT.
Perfect Mass Flow Units	Volumetrically based mass flow units of measure that assume ideal gas behavior for all gases (compressibility factor of 1).
PM (Pressure Multiplier)	Pressure <i>multiplier</i> , used in calibration to adjust span of an RPT.
Process Gas	The gas for which a device under test is to be characterized or calibrated. The gas that will actually flow in the device under test when it is used in a process.

PRT	Platinum Resistance Thermometer. The element used in molbloccs to measure temperature.
Psia	Pressure unit “pounds per square inch absolute”. Pressure expressed relative to vacuum.
Psig	Pressure unit “pounds per square inch gauge”. Pressure expressed relative to atmospheric pressure.
Rate	A DISPLAY function in which the current rate of change of the flow in flow units/second is displayed. A measure of stability of the flow. See also Stability Limit.
Ready/Not Ready	Indication of when flow is stable within the stability limit and below the flow Reynolds number limit. See also Stability Limit.
Reynolds Number	A ratio of the inertia forces to the viscous forces in a flowing fluid. This dimensionless number, which is dependent on fluid viscosity, density, velocity and length of the flow field, is often used to predict a boundary point between laminar and turbulent flow regimes.
RPT	Reference Pressure Transducer. The pressure transducers used in molbox RFM are referred to as RPTs.
Single P Calibration	A molbloc calibration option for gases other than N2 which is valid at a single specified operating pressure.
Stability Limit	A limit expressed in units of flow per second (e.g., sccm/second). The stability limit is used as the <i>Ready/Not Ready</i> criterion <i>Ready</i> (<*) if rate is less than stability limit, <i>Not Ready</i> (<↑> or <↓>) if rate is greater than stability limit. See also Rate.
Surrogate Gas	A gas whose behavior, from the standpoint of a device under test, is similar to the process gas for which the device is to be characterized and used. A surrogate gas is often used in calibration and testing when the process gas cannot be used for safety or cost reasons.
Target	The value from which deviations are measured in the DEVIATION DISPLAY function.
Test Gas	The gas flowing through the molbloc that is being used to run the test or calibration. The test gas, from the standpoint of the device under test, could be a surrogate gas or the process gas.
Totalize	A DISPLAY function in which the total mass or volume flowed over a period of time is accumulated.
Upstream	Location of point A relative to point B in a flow system in which point A is at a different location in the opposite direction of the flow. For example, the upstream molbloc pressure port is upstream relative to the downstream pressure port because it is at a different location from the downstream port in the opposite direction of the flow.
User Level	Level of security that can be set to prevent access to certain molbox RFM functions.
User Mass Flow Units	Volumetrically based mass flow units of measure with a user set reference temperature.
venturi nozzle	A flow orifice using a specific shape characterized by a convergent and divergent section, used to define flow measurements by measurement of flow conditions and gas properties. A critical flow venturi nozzle is a venturi nozzle used to define flows within the critical flow regime.
Volume Flow Pressure	The absolute pressure of the flowing gas at the device under test for volume flow units of measure.
Volume Flow Temperature	The temperature of the flowing gas at the device under test for volume flow units of measure.
Volume Flow Units	Units of measure of volume flow.