

## Application



Intended for side wall installation, the general purpose level switch package provides reliable liquid level detection with a 16A compact level controller for pump or valve control. The optional flash alarm brings attention to alarm conditions. Offered in two level sensor technologies, select the type and material based upon your application media. This liquid level switch package is widely applied in bulk storage and process tank level applications for high level control or low level control.



## Features

- ✓ Rugged polypropylene, Ryton® or PFA sensor for corrosive liquid applications
- ✓ Fail-safe relay control of pumps or valves with 0-60 second delay
- ✓ Polypropylene enclosure rated NEMA 4X with swivel base for conduit alignment
- ✓ Optional strobe brings immediate attention to level alarm conditions
- ✓ Invert switch changes relay state from NO to NC without rewiring
- ✓ Offered in 2 sensing technologies for broad application coverage: ultrasonic & vibration

## Key Benefits

- ✓ Ideal for side wall tank mounting
- ✓ Relay output interfaces directly with valves, buzzers, alarms, etc.
- ✓ Great for corrosive or coating liquids
- ✓ Add strobe for optional visual alarm

## Compatible Products

### Switch-Tek™ Ultrasonic Level Switch

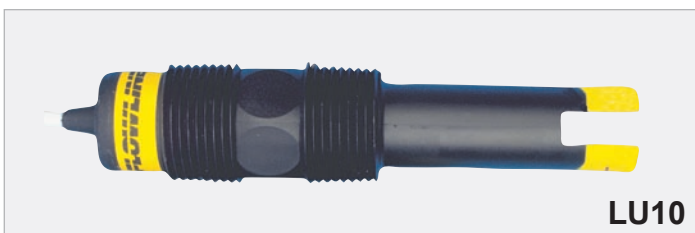

**LU10**

Broadly applied in chemicals and light weight oils

### Switch-Tek™ Vibration Level Switch



**LZ12**

Applied in wastewater with light coating or scaling

## Specifications

Accuracy:	± 1mm in water
Repeatability:	± 0.5mm in water
LED indication:	Sensor, power & relay
Supply voltage:	120 / 240 VAC @ 50-60 Hz.
Consumption:	0.25A maximum
Strobe type:	-X12X: N/A -X11X: Xenon tube
Strobe flash:	-X12X: N/A -X11X: (1) per second
Contact type:	(1) SPST relay
Contact rating:	250 VAC @ 10A
Contact output:	Selectable NO / NC
Contact delay:	0-60 seconds
Process temp.:	F: -40° to 176° C: -40° to 80°
Ambient temp.:	F: -40° to 140° C: -40° to 60°
Pressure:	150 psi (10 bar) @ 25° C, derated @ 1.667 psi (0.113 bar) per °C above 25° C
Enclosure rating:	NEMA 4X (IP65)
Enclosure mat.:	-X11X: PP, UL94VO & PC -X12X: PP, UL94VO
Conduit entrance:	1/2" NPT
Wetted material:	AZ13-11XX: Ryton® AU13-11XX: PP AU13-21XX: PFA
Process mount:	3/4" NPT (3/4" G)
Mount. gasket:	Viton®
Classification:	General purpose
Compliance:	CE

## Dimensions

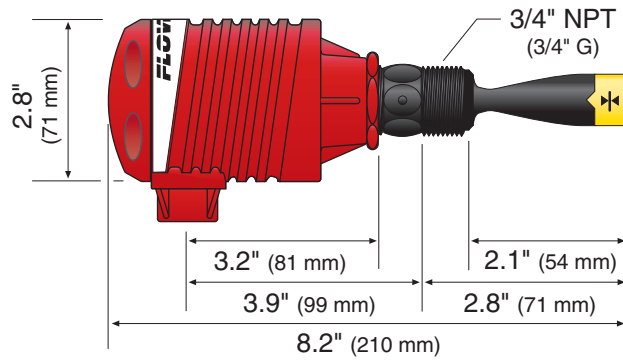

## Accessories



### Strobe Alert

The controller with Strobe Alert configuration flashes when the relay is energized during a high or low level alarm condition.

## Installation

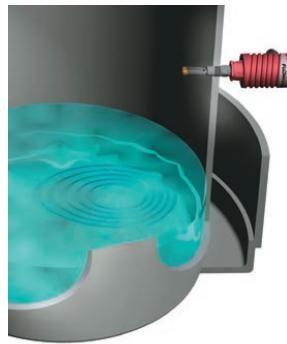

### Side Wall Installation

The Switch-Pro AX13 series is designed for installation through the side wall of the tank. The sensor can be used as a high or low level alarm as well as overflow protection or low level pump protection. Use a tank adapter to make installation quick and simple.

## Ordering

A  13-  1

### Sensor technology (1)

- Z Vibration
- U Ultrasonic

### Wetted material (2)

- 1 PP/Ryton
- 2 PFA

### Configuration

- 1 Controller with Strobe Alert
- 2 Controller only

### Process mount

- 0 NPT (US)
- 4 G (Metric)

### Notes

- 1) Select the best level sensor technology based upon your application.
- 2) PFA is available in ultrasonic configuration only