

Operating Instructions

Proline Prosonic Flow W 400

Ultrasonic transit time flowmeter
HART



- Make sure the document is stored in a safe place such that it is always available when working on or with the device.
- To avoid danger to individuals or the facility, read the "Basic safety instructions" section carefully, as well as all other safety instructions in the document that are specific to working procedures.
- The manufacturer reserves the right to modify technical data without prior notice. Your Endress+Hauser Sales Center will supply you with current information and updates to these instructions.

Table of contents

1	About this document	6			
1.1	Document function	6			
1.2	Symbols	6			
1.2.1	Safety symbols	6			
1.2.2	Electrical symbols	6			
1.2.3	Communication-specific symbols	6			
1.2.4	Tool symbols	7			
1.2.5	Symbols for certain types of information	7			
1.2.6	Symbols in graphics	7			
1.3	Documentation	8			
1.3.1	Standard documentation	8			
1.3.2	Supplementary device-dependent documentation	8			
1.4	Registered trademarks	8			
2	Safety instructions	9			
2.1	Requirements for the personnel	9			
2.2	Intended use	9			
2.3	Workplace safety	10			
2.4	Operational safety	10			
2.5	Product safety	10			
2.6	IT security	11			
2.7	Device-specific IT security	11			
2.7.1	Protecting access via a password	11			
2.7.2	Access via Web server	12			
3	Product description	13			
3.1	Product design	14			
4	Incoming acceptance and product identification	15			
4.1	Incoming acceptance	15			
4.2	Product identification	15			
4.2.1	Transmitter nameplate	16			
4.2.2	Sensor nameplate	16			
4.2.3	Symbols on measuring device	17			
5	Storage and transport	18			
5.1	Storage conditions	18			
5.2	Transporting the product	18			
5.2.1	Transporting with a fork lift	18			
5.3	Packaging disposal	18			
6	Mounting	19			
6.1	Mounting requirements	19			
6.1.1	Mounting position	19			
6.1.2	Sensor set selection and arrangement	23			
6.1.3	Environment and process requirements	27			
			6.1.4	Special mounting instructions	27
			6.2	Mounting the measuring device	28
			6.2.1	Required tools	28
			6.2.2	Preparing the measuring device	28
			6.2.3	Mounting the sensor	28
			6.2.4	Mounting the transmitter	40
			6.2.5	Turning the display module	42
			6.3	Post-mounting check	42
			7	Electrical connection	44
			7.1	Electrical safety	44
			7.2	Connection conditions	44
			7.2.1	Required tools	44
			7.2.2	Requirements for connecting cable	44
			7.2.3	Terminal assignment	45
			7.2.4	Preparing the measuring device	46
			7.3	Connecting the measuring device	46
			7.3.1	Connecting the sensor and transmitter	46
			7.3.2	Connecting the transmitter	48
			7.3.3	Potential equalization	49
			7.4	Special connection instructions	49
			7.4.1	Connection examples	49
			7.5	Ensuring the degree of protection	51
			7.5.1	Degree of protection IP66/67, Type 4X enclosure	51
			7.6	Post-connection check	51
			8	Operation options	52
			8.1	Overview of operation methods	52
			8.2	Structure and function of the operating menu	53
			8.2.1	Structure of the operating menu	53
			8.2.2	Operating philosophy	54
			8.3	Access to the operating menu via the local display	55
			8.3.1	Operational display	55
			8.3.2	Navigation view	56
			8.3.3	Editing view	58
			8.3.4	Operating elements	60
			8.3.5	Opening the context menu	60
			8.3.6	Navigating and selecting from list	62
			8.3.7	Calling the parameter directly	62
			8.3.8	Calling up help text	63
			8.3.9	Changing the parameters	64
			8.3.10	User roles and related access authorization	65
			8.3.11	Disabling write protection via access code	65
			8.3.12	Enabling and disabling the keypad lock	66
			8.4	Access to the operating menu via the Web browser	66
			8.4.1	Function scope	66

8.4.2	Requirements	66	11.3	Configuring the display	116
8.4.3	Establishing a connection	67	11.4	Reading off measured values	116
8.4.4	Logging on	69	11.4.1	Process variables	117
8.4.5	User interface	70	11.4.2	System values	117
8.4.6	Disabling the Web server	71	11.4.3	Input values	118
8.4.7	Logging out	71	11.4.4	Output values	119
8.5	Access to the operating menu via the operating tool	71	11.4.5	"Totalizer" submenu	120
8.5.1	Connecting the operating tool	72	11.5	Adapting the measuring device to the process conditions	120
8.5.2	FieldCare	74	11.6	Performing a totalizer reset	120
8.5.3	DeviceCare	75	11.6.1	Function scope of the "Control Totalizer" parameter	121
8.5.4	Field Xpert SMT70, SMT77	75	11.6.2	Function scope of the "Reset all totalizers" parameter	121
8.5.5	AMS Device Manager	76	11.7	Show data logging	122
8.5.6	SIMATIC PDM	76	12	Diagnostics and troubleshooting ..	125
9	System integration	77	12.1	General troubleshooting	125
9.1	Overview of device description files	77	12.2	Diagnostic information via light emitting diodes	127
9.1.1	Current version data for the device ...	77	12.2.1	Transmitter	127
9.1.2	Operating tools	77	12.3	Diagnostic information on local display	128
9.2	Measured variables via HART protocol	77	12.3.1	Diagnostic message	128
9.3	Other settings	79	12.3.2	Calling up remedial measures	130
10	Commissioning	81	12.4	Diagnostic information in the Web browser .	130
10.1	Function check	81	12.4.1	Diagnostic options	130
10.2	Switching on the measuring device	81	12.4.2	Calling up remedy information	131
10.3	Setting the operating language	81	12.5	Diagnostic information in FieldCare or DeviceCare	132
10.4	Configuring the measuring device	81	12.5.1	Diagnostic options	132
10.4.1	Defining the tag name	82	12.5.2	Calling up remedy information	133
10.4.2	Setting the system units	83	12.6	Adapting the diagnostic information	133
10.4.3	Configuring the measuring point	84	12.6.1	Adapting the diagnostic behavior ...	133
10.4.4	Checking the installation status	88	12.6.2	Adapting the status signal	133
10.4.5	Configuring the status input	89	12.7	Overview of diagnostic information	134
10.4.6	Configuring the current output	91	12.8	Pending diagnostic events	137
10.4.7	Configuring the pulse/frequency/ switch output	92	12.9	Diagnostic list	138
10.4.8	Configuring the local display	97	12.10	Event logbook	139
10.4.9	Configuring the low flow cut off	99	12.10.1	Reading out the event logbook	139
10.5	Advanced settings	101	12.10.2	Filtering the event logbook	140
10.5.1	Using the parameter to enter the access code	102	12.10.3	Overview of information events	140
10.5.2	Carrying out a sensor adjustment ...	102	12.11	Resetting the measuring device	141
10.5.3	Configuring the totalizer	102	12.11.1	Function scope of the "Device reset" parameter	141
10.5.4	Carrying out additional display configurations	104	12.12	Device information	141
10.5.5	WLAN configuration	106	12.13	Firmware history	143
10.5.6	Performing Heartbeat basic setup ..	108	13	Maintenance	144
10.5.7	Using parameters for device administration	109	13.1	Maintenance tasks	144
10.6	Simulation	111	13.1.1	Exterior cleaning	144
10.7	Protecting settings from unauthorized access	113	13.2	Measuring and test equipment	144
10.7.1	Write protection via access code ...	113	13.3	Endress+Hauser services	144
10.7.2	Write protection via write protection switch	114	14	Repair	145
11	Operation	116	14.1	General information	145
11.1	Reading the device locking status	116	14.1.1	Repair and conversion concept	145
11.2	Adjusting the operating language	116	14.1.2	Notes for repair and conversion	145

14.2	Spare parts	145
14.3	Endress+Hauser services	145
14.4	Return	145
14.5	Disposal	146
	14.5.1 Removing the measuring device	146
	14.5.2 Disposing of the measuring device ..	146
15	Accessories	147
15.1	Device-specific accessories	147
	15.1.1 For the transmitter	147
	15.1.2 For the sensor	147
15.2	Communication-specific accessories	148
15.3	Service-specific accessories	149
15.4	System components	149
16	Technical data	150
16.1	Application	150
16.2	Function and system design	150
16.3	Input	150
16.4	Output	151
16.5	Power supply	154
16.6	Performance characteristics	155
16.7	Installation	157
16.8	Environment	157
16.9	Process	158
16.10	Mechanical construction	159
16.11	Operability	160
16.12	Certificates and approvals	164
16.13	Application packages	165
16.14	Accessories	166
16.15	Documentation	166
Index	168	

1 About this document

1.1 Document function

These Operating Instructions contain all the information that is required in various phases of the life cycle of the device: from product identification, incoming acceptance and storage, to mounting, connection, operation and commissioning through to troubleshooting, maintenance and disposal.

1.2 Symbols

1.2.1 Safety symbols

DANGER

This symbol alerts you to a dangerous situation. Failure to avoid this situation will result in serious or fatal injury.

WARNING

This symbol alerts you to a dangerous situation. Failure to avoid this situation can result in serious or fatal injury.





CAUTION

This symbol alerts you to a dangerous situation. Failure to avoid this situation can result in minor or medium injury.



NOTICE



This symbol contains information on procedures and other facts which do not result in personal injury.

1.2.2 Electrical symbols



Symbol	Meaning
	Direct current
	Alternating current
	Direct current and alternating current
	Ground connection A grounded terminal which, as far as the operator is concerned, is grounded via a grounding system.
	Protective Earth (PE) A terminal which must be connected to ground prior to establishing any other connections. The ground terminals are situated inside and outside the device: <ul style="list-style-type: none"> ▪ Inner ground terminal: Connects the protective earth to the mains supply. ▪ Outer ground terminal: Connects the device to the plant grounding system.

1.2.3 Communication-specific symbols











Symbol	Meaning
	Wireless Local Area Network (WLAN) Communication via a wireless, local network.
	Bluetooth Wireless data transmission between devices over a short distance.
	LED Light emitting diode is off.

Symbol	Meaning
	LED Light emitting diode is on.
	LED Light emitting diode is flashing.

1.2.4 Tool symbols



Symbol	Meaning
	Torx screwdriver
	Phillips head screwdriver
	Open-ended wrench

1.2.5 Symbols for certain types of information

Symbol	Meaning
	Permitted Procedures, processes or actions that are permitted.
	Preferred Procedures, processes or actions that are preferred.
	Forbidden Procedures, processes or actions that are forbidden.
	Tip Indicates additional information.
	Reference to documentation
	Reference to page
	Reference to graphic
	Notice or individual step to be observed
1, 2, 3...	Series of steps
	Result of a step
	Help in the event of a problem
	Visual inspection

1.2.6 Symbols in graphics

Symbol	Meaning
1, 2, 3, ...	Item numbers
1, 2, 3, ...	Series of steps
A, B, C, ...	Views
A-A, B-B, C-C, ...	Sections
	Hazardous area

Symbol	Meaning
	Safe area (non-hazardous area)
	Flow direction

1.3 Documentation

 For an overview of the scope of the associated Technical Documentation, refer to the following:

- *W@M Device Viewer* (www.endress.com/deviceviewer): Enter the serial number from the nameplate
- *Endress+Hauser Operations App*: Enter the serial number from the nameplate or scan the matrix code on the nameplate

 Detailed list of the individual documents along with the documentation code

1.3.1 Standard documentation

Document type	Purpose and content of the document
Technical Information	Planning aid for your device The document contains all the technical data on the device and provides an overview of the accessories and other products that can be ordered for the device.
Sensor Brief Operating Instructions	Getting the 1st measured value quickly - Part 1 The Sensor Brief Operating Instructions are aimed at specialists with responsibility for installing the measuring device. <ul style="list-style-type: none"> ▪ Incoming acceptance and product identification ▪ Storage and transport ▪ Installation
Transmitter Brief Operating Instructions	Getting the 1st measured value quickly - Part 2 The Transmitter Brief Operating Instructions are aimed at specialists with responsibility for commissioning, configuring and parameterizing the measuring device (until the first measured value). <ul style="list-style-type: none"> ▪ Product description ▪ Installation ▪ Electrical connection ▪ Operation options ▪ System integration ▪ Commissioning ▪ Diagnostic information
Description of Device Parameters	Reference for your parameters The document provides a detailed explanation of each individual parameter in the Expert operating menu. The description is aimed at those who work with the device over the entire life cycle and perform specific configurations.

1.3.2 Supplementary device-dependent documentation

Additional documents are supplied depending on the device version ordered: Always comply strictly with the instructions in the supplementary documentation. The supplementary documentation is an integral part of the device documentation.

1.4 Registered trademarks

HART®

Registered trademark of the FieldComm Group, Austin, USA

2 Safety instructions

2.1 Requirements for the personnel

The personnel for installation, commissioning, diagnostics and maintenance must fulfill the following requirements:

- ▶ Trained, qualified specialists must have a relevant qualification for this specific function and task.
- ▶ Are authorized by the plant owner/operator.
- ▶ Are familiar with federal/national regulations.
- ▶ Before starting work, read and understand the instructions in the manual and supplementary documentation as well as the certificates (depending on the application).
- ▶ Follow instructions and comply with basic conditions.

The operating personnel must fulfill the following requirements:

- ▶ Are instructed and authorized according to the requirements of the task by the facility's owner-operator.
- ▶ Follow the instructions in this manual.

2.2 Intended use

Application and media

The measuring device described in this manual is intended only for the flow measurement of liquids.

Depending on the version ordered, the measuring device can also measure potentially explosive, flammable, poisonous and oxidizing media.

Measuring devices for use in hazardous areas, in hygienic applications or in applications where there is an increased risk due to process pressure, are marked accordingly on the nameplate.

To ensure that the measuring device remains in proper condition for the operation time:

- ▶ Keep within the specified temperature range.
- ▶ Only use the measuring device in full compliance with the data on the nameplate and the general conditions listed in the Operating Instructions and supplementary documentation.
- ▶ Based on the nameplate, check whether the ordered device is permitted for the intended use in the hazardous area (e.g. explosion protection, pressure vessel safety).
- ▶ If the ambient temperature of the measuring device is outside the atmospheric temperature, it is absolutely essential to comply with the relevant basic conditions as specified in the device documentation → 8.
- ▶ Protect the measuring device permanently against corrosion from environmental influences.

Incorrect use

Non-designated use can compromise safety. The manufacturer is not liable for damage caused by improper or non-designated use.

Residual risks



If the temperature of the media or electronics unit is high or low, this may cause the surfaces of the device to become hot or cold. This poses a risk of burns or frostbite!

- ▶ In the case of hot or cold medium temperatures, install appropriate protection against contact.

2.3 Workplace safety

For work on and with the device:

- ▶ Wear the required personal protective equipment according to national regulations.

If mounting the sensors and tensioning bands:

- ▶ Due to the increased risk of cuts, wear suitable gloves and protective goggles.

For welding work on the piping:

- ▶ Do not ground the welding unit via the measuring device.

If working on and with the device with wet hands:

- ▶ Due to the increased risk of electric shock, wear suitable gloves.

2.4 Operational safety

Risk of injury.

- ▶ Operate the device in proper technical condition and fail-safe condition only.
- ▶ The operator is responsible for interference-free operation of the device.

Conversions to the device

Unauthorized modifications to the device are not permitted and can lead to unforeseeable dangers.

- ▶ If, despite this, modifications are required, consult with Endress+Hauser.

Repair

To ensure continued operational safety and reliability,

- ▶ Carry out repairs on the device only if they are expressly permitted.
- ▶ Observe federal/national regulations pertaining to repair of an electrical device.
- ▶ Use original spare parts and accessories from Endress+Hauser only.

2.5 Product safety

This measuring device is designed in accordance with good engineering practice to meet state-of-the-art safety requirements, has been tested, and left the factory in a condition in which it is safe to operate.

It meets general safety standards and legal requirements. It also complies with the EU directives listed in the device-specific EU Declaration of Conformity. Endress+Hauser confirms this by affixing the CE mark to the device.

Furthermore, the device meets the legal requirements of the applicable UK regulations (Statutory Instruments). These are listed in the UKCA Declaration of Conformity along with the designated standards.

By selecting the order option for UKCA marking, Endress+Hauser confirms a successful evaluation and testing of the device by affixing the UKCA mark.

Contact address Endress+Hauser UK:

Endress+Hauser Ltd.
Floats Road
Manchester M23 9NF
United Kingdom
www.uk.endress.com



2.6 IT security

Our warranty is valid only if the device is installed and used as described in the Operating Instructions. The device is equipped with security mechanisms to protect it against any inadvertent changes to the settings.

IT security measures, which provide additional protection for the device and associated data transfer, must be implemented by the operators themselves in line with their security standards.

2.7 Device-specific IT security

The device offers a range of specific functions to support protective measures on the operator's side. These functions can be configured by the user and guarantee greater in-operation safety if used correctly. An overview of the most important functions is provided in the following section:

Function/interface	Factory setting	Recommendation
Write protection via hardware write protection switch	Not enabled	On an individual basis following risk assessment
Access code (also applies for Web server login or FieldCare connection) →  11	Not enabled (0000)	Assign a customized access code during commissioning
WLAN (order option in display module)	Enabled	On an individual basis following risk assessment
WLAN security mode	Enabled (WPA2-PSK)	Do not change
WLAN passphrase (password) →  11	Serial number	Assign a customized WLAN passphrase during commissioning
WLAN mode	Access point	On an individual basis following risk assessment
Web server →  12	Enabled	On an individual basis following risk assessment
CDI-RJ45 service interface	–	On an individual basis following risk assessment

2.7.1 Protecting access via a password

Different passwords are available to protect write access to the device parameters or access to the device via the WLAN interface.

- **User-specific access code**
Protect write access to the device parameters via the local display, Web browser or operating tool (e.g. FieldCare, DeviceCare). Access authorization is clearly regulated through the use of a user-specific access code.
- **WLAN passphrase**
The network key protects a connection between an operating unit (e.g. notebook or tablet) and the device via the WLAN interface which can be ordered as an option.

User-specific access code

Write access to the device parameters via the local display or operating tool (e.g. FieldCare, DeviceCare) can be protected by the modifiable, user-specific access code (→  113).

When the device is delivered, the device does not have an access code and is equivalent to 0000 (open).

WLAN passphrase: Operation as WLAN access point

A connection between an operating unit (e.g. notebook or tablet) and the device via the WLAN interface (→  72), which can be ordered as an optional extra, is protected by

the network key. The WLAN authentication of the network key complies with the IEEE 802.11 standard.

When the device is delivered, the network key is pre-defined depending on the device. It can be changed via the **WLAN settings** submenu in the **WLAN passphrase** parameter (→  108).

General notes on the use of passwords

- The access code and network key supplied with the device should be changed during commissioning.
- Follow the general rules for generating a secure password when defining and managing the access code or network key.
- The user is responsible for the management and careful handling of the access code and network key.
- For information on configuring the access code or on what to do if you lose the password, for example, see the "Write protection via access code" section →  113

2.7.2 Access via Web server

The device can be operated and configured via a Web browser with the integrated Web server (→  66). The connection is via the service interface (CDI-RJ45) or the WLAN interface.

The Web server is enabled when the device is delivered. The Web server can be disabled if necessary (e.g. after commissioning) via the **Web server functionality** parameter.

The device and status information can be hidden on the login page. This prevents unauthorized access to the information.



For detailed information on device parameters, see:
The "Description of Device Parameters" document .

3 Product description

The measuring system consists of a transmitter and one or two sensor sets. The transmitter and sensor sets are mounted in physically separate locations. They are interconnected by sensor cables.

The measuring system uses a measurement method based on the transit time difference. Here, the sensors work as sound generators and sound receivers. Depending on the application and version, the sensors can be arranged for a measurement via 1, 2, 3 or 4 traverses →  23.

The transmitter serves to control the sensor sets, to prepare, process and evaluate the measuring signals, and to convert the signals to the desired output variable.

3.1 Product design

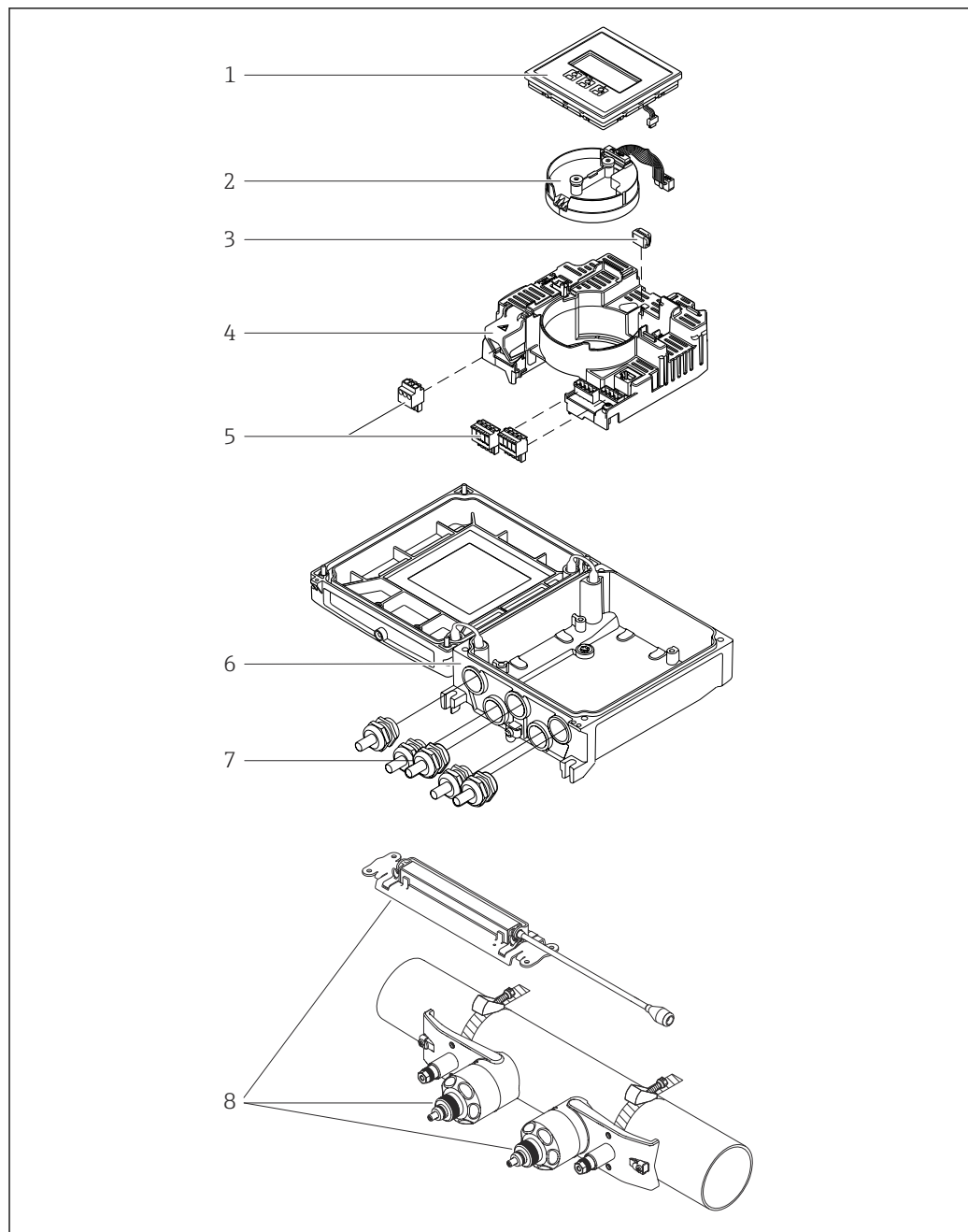

A0045030

1 Important components

- 1 Display module
- 2 Smart sensor electronics module
- 3 HistoROM DAT (plug-in memory)
- 4 Main electronics module
- 5 Terminals (screw terminals, some available as plug-in terminals) or fieldbus connectors
- 6 Transmitter housing
- 7 Cable glands
- 8 Sensor (2 versions)

4 Incoming acceptance and product identification

4.1 Incoming acceptance

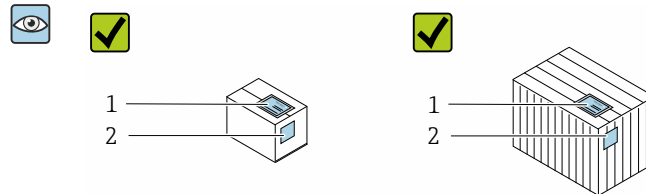

Are the order codes on the delivery note (1) and the product sticker (2) identical?

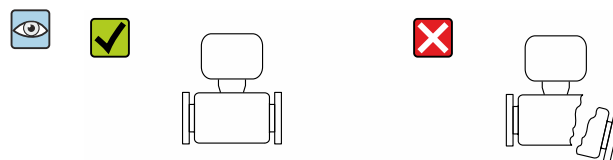
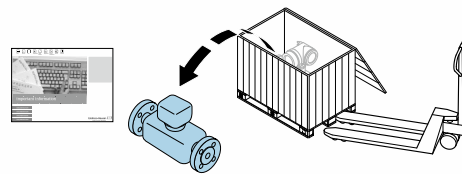

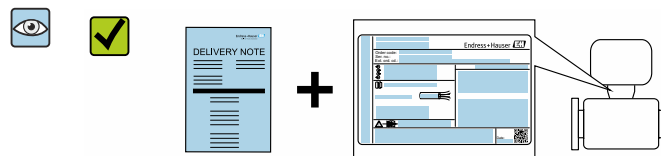

Are the goods undamaged?

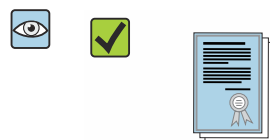

Do the nameplate data match the ordering information on the delivery note?



Is the envelope present with accompanying documents?



-  If one of the conditions is not satisfied, contact your Endress+Hauser Sales Center.
- The Technical Documentation is available via the Internet or via the *Endress+Hauser Operations App*, see the "Product identification" section →  16.

4.2 Product identification

The following options are available for identification of the device:

- Nameplate specifications
- Order code with breakdown of the device features on the delivery note
- Enter the serial numbers from the nameplates in *W@M Device Viewer* (www.endress.com/deviceviewer): all the information about the device is displayed.
- Enter the serial numbers from the nameplates into the *Endress+Hauser Operations App* or scan the DataMatrix code on the nameplate with the *Endress+Hauser Operations App*: all the information about the device is displayed.

For an overview of the scope of the associated Technical Documentation, refer to the following:

- The chapters "Additional standard documentation on the device" →  8 and "Supplementary device-dependent documentation" →  8
- The *W@M Device Viewer*: Enter the serial number from the nameplate (www.endress.com/deviceviewer)
- The *Endress+Hauser Operations App*: Enter the serial number from the nameplate or scan the DataMatrix code on the nameplate.

4.2.1 Transmitter nameplate

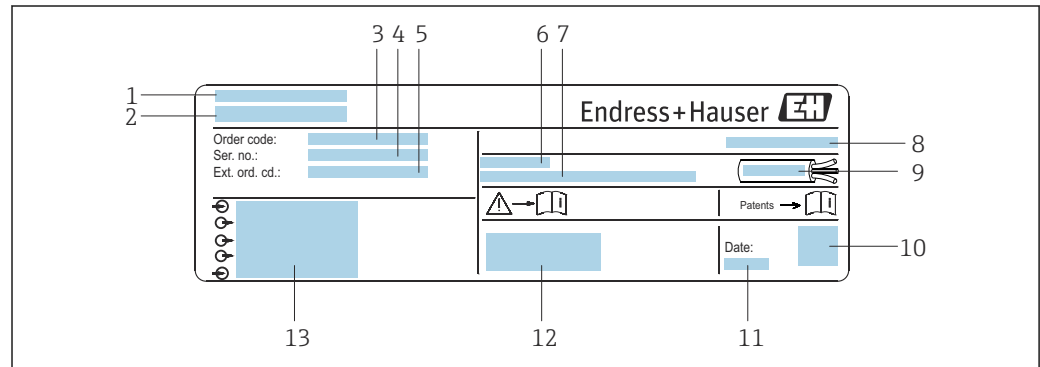

A0017346

 2 Example of a transmitter nameplate

- 1 Place of manufacture
- 2 Name of the transmitter
- 3 Order code
- 4 Serial number (Ser. no.)
- 5 Extended order code (Ext. ord. cd.)
- 6 Permitted ambient temperature (T_a)
- 7 Firmware version (FW) and device revision (Dev.Rev.) from the factory
- 8 Degree of protection
- 9 Permitted temperature range for cable
- 10 2-D matrix code
- 11 Date of manufacture: year-month
- 12 CE mark, RCM-Tick mark
- 13 Electrical connection data, e.g. available inputs and outputs, supply voltage

4.2.2 Sensor nameplate

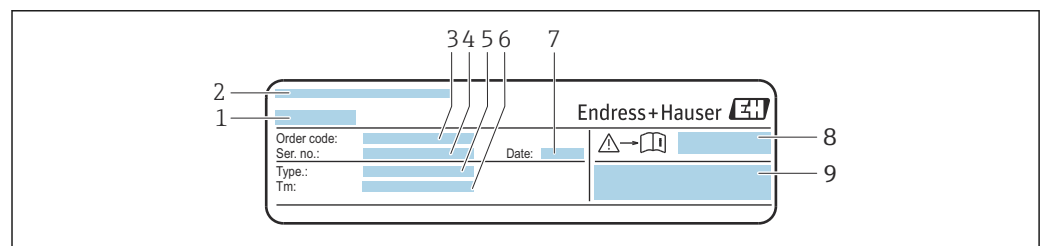

A0043306

 3 Example of sensor nameplate, "front"

- 1 Name of sensor
- 2 Place of manufacture
- 3 Order code
- 4 Serial number (Ser. no.)
- 5 Type
- 6 Medium temperature range
- 7 Date of manufacture: year-month
- 8 Document number of safety-related supplementary documentation
- 9 Additional information



A0043305

4 Example of sensor nameplate, "back"

1 CE mark, RCM-Tick mark, approval information on explosion protection and degree of protection

i Order code

The measuring device is reordered using the order code.

Extended order code

- The device type (product root) and basic specifications (mandatory features) are always listed.
- Of the optional specifications (optional features), only the safety and approval-related specifications are listed (e.g. LA). If other optional specifications are also ordered, these are indicated collectively using the # placeholder symbol (e.g. #LA#).
- If the ordered optional specifications do not include any safety and approval-related specifications, they are indicated by the + placeholder symbol (e.g. XXXXXX-ABCDE+).

4.2.3 Symbols on measuring device

Symbol	Meaning
	WARNING! This symbol alerts you to a dangerous situation. Failure to avoid this situation can result in serious or fatal injury. To determine the nature of the potential hazard and the measures required to avoid it, consult the documentation accompanying the measuring device.
	Reference to documentation Refers to the corresponding device documentation.
	Protective ground connection A terminal which must be connected to ground prior to establishing any other connections.

5 Storage and transport

5.1 Storage conditions

Observe the following notes for storage:

- ▶ Store in the original packaging to ensure protection from shock.
- ▶ Protect from direct sunlight to avoid unacceptably high surface temperatures.
- ▶ Store in a dry and dust-free place.
- ▶ Do not store outdoors.

Storage temperature →  158

5.2 Transporting the product

Transport the measuring device to the measuring point in the original packaging.

5.2.1 Transporting with a fork lift

If transporting in wood crates, the floor structure enables the crates to be lifted lengthwise or at both sides using a forklift.

5.3 Packaging disposal

All packaging materials are environmentally friendly and 100 % recyclable:

- Outer packaging of device
 - Polymer stretch wrap, complying with EU Directive 2002/95/EC (RoHS)
- Packaging
 - Wooden crate treated in accordance with ISPM 15 standard, confirmed by IPPC logo
 - Cardboard box in accordance with European packaging guideline 94/62EC, recyclability confirmed by Resy symbol
- Carrying and securing materials
 - Disposable plastic pallet
 - Plastic straps
 - Plastic adhesive strips
- Filler material
 - Paper pads

6 Mounting

6.1 Mounting requirements

6.1.1 Mounting position

Mounting location

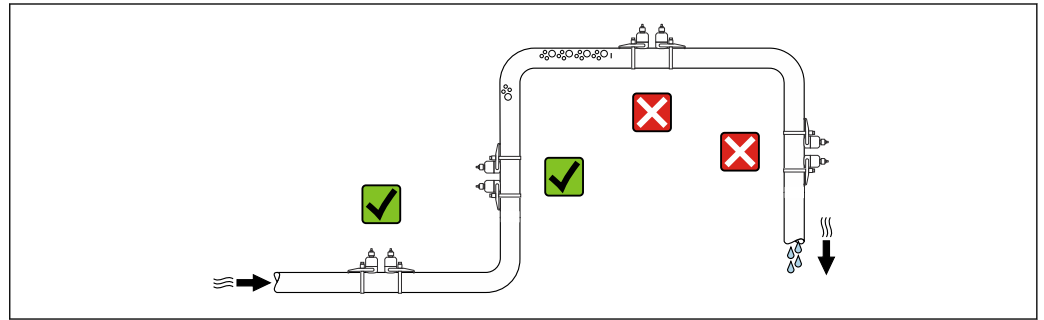

A0042039

To prevent measuring errors arising from accumulation of gas bubbles in the measuring pipe, avoid the following mounting locations in the piping:

- Highest point of a pipeline.
- Directly upstream of a free pipe outlet in a down pipe.

Orientation

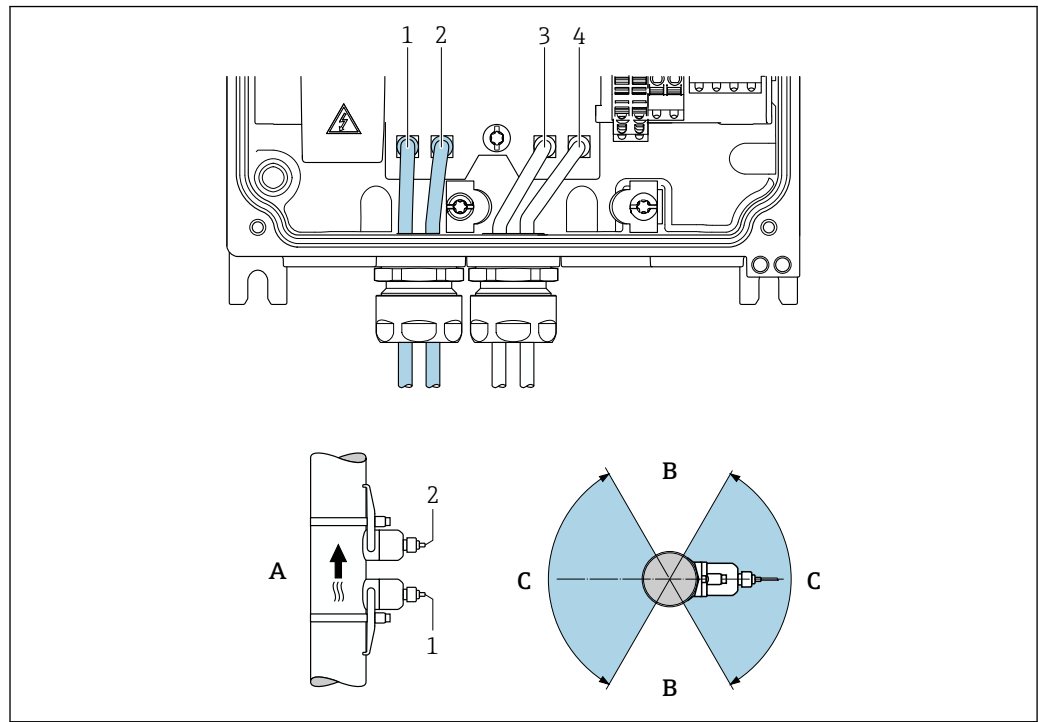

5 Orientation views

- 1 Channel 1 upstream
- 2 Channel 1 downstream
- 3 Channel 2 upstream
- 4 Channel 2 downstream
- A Recommended orientation with upward direction of flow
- B Non-recommended installation range with horizontal orientation (60°)
- C Recommended installation range max. 120°

Vertical

Recommended orientation with upward direction of flow (View A). With this orientation, entrained solids will sink and gases will rise away from the sensor area when the medium is not flowing. Furthermore, the pipe can be completely drained and protected against the buildup of deposits.

Horizontal

In the recommended installation range with a horizontal orientation (View B), gas and air accumulations at the top of the pipe and interference from deposit buildup at the bottom of the pipe can influence the measurement to a lesser degree.

Inlet and outlet runs

If possible, the sensor should be installed upstream from valves, T-sections, pumps etc. If this is not possible, the inlet and outlet runs indicated below must be maintained at the very minimum in order to attain the specified level of accuracy of the measuring device. If there are several flow disturbances present, the longest specified inlet run must be maintained.

-  Shorter inlet and outlet runs are possible with the following device versions:
Two-path measurement with 2 sensor sets¹⁾ and order code for "Application package", option EN "FlowDC" → 167 (for item numbers 1 to 4b):
Up to minimum 2 × DN for inlet run, 2 × DN for outlet run

1) Order code for "Mounting type", option A2 "Clamp-on, 2-channel, 2-sensor sets"

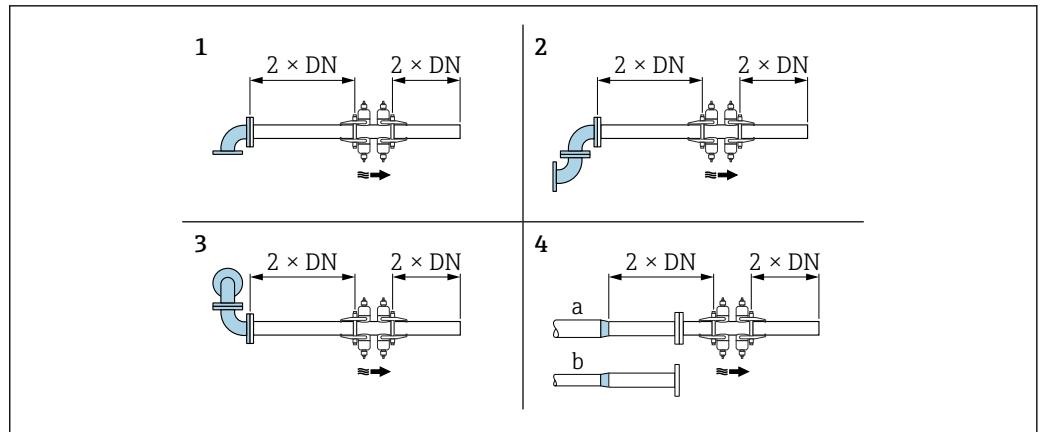

A0044471

6 Minimum inlet and outlet runs with FlowDC with various flow obstructions

- 1 Pipe bend
- 2 Two pipe bends (on one plane)
- 3 Two pipe bends (on two planes)
- 4a Reduction
- 4b Extension

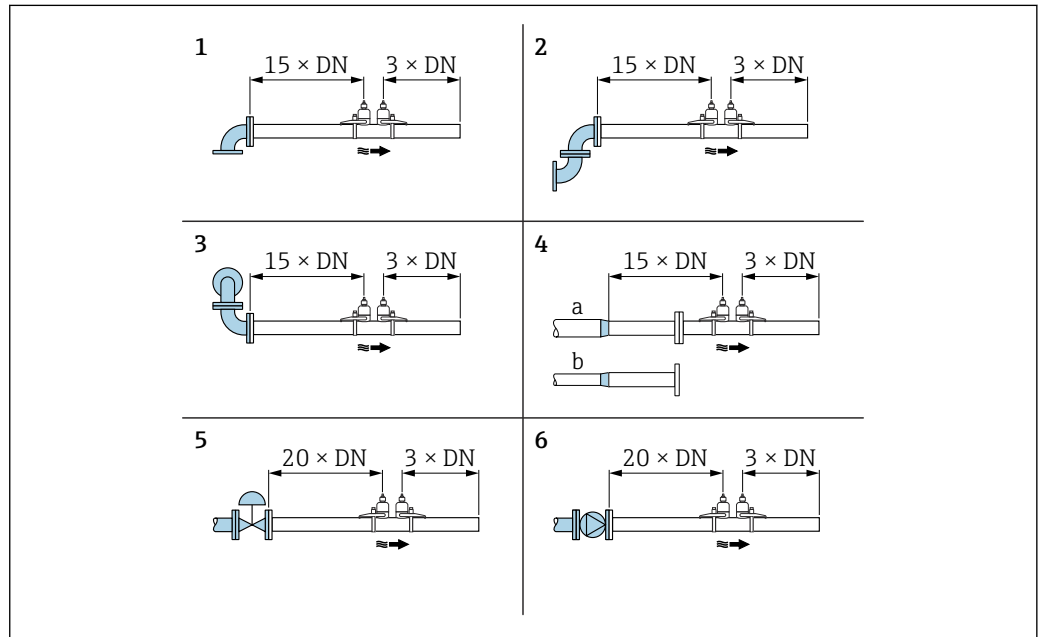

A0042041

7 Minimum inlet and outlet runs without FlowDC with 1 or 2 sensor sets with various flow obstructions

- 1 Pipe bend
- 2 Two pipe bends (on one plane)
- 3 Two pipe bends (on two planes)
- 4a Reduction
- 4b Extension
- 5 Control valve (2/3 open)
- 6 Pump

Operation

Single-path measurement

In the case of single-path measurement, the flow is measured at the measuring point without the option of compensation.

For this it is necessary to adhere strictly to the specified inlet and outlet runs after disturbances in the measuring pipe (e.g. elbows, extensions, reductions).

i To ensure the best possible measurement performance and measuring accuracy, the configuration with two sensor sets ²⁾ with FlowDC ³⁾ is recommended.

Two-path measurement

In the case of two-path measurement, the flow is measured by two measurements (two measuring paths/sensor sets) at the measuring point.

The two sensor sets are mounted at one measuring point with one or two traverses for this purpose. It is generally possible to arrange the sensors on one or two different measurement planes. If the sensors are installed with two measurement planes, a minimum sensor plane rotation of 30° in relation to the pipe axis must be observed.

The average of the measured values of both sensor sets is calculated. The configuration of the measurement is only performed once and is adopted for both measuring paths.

i When extending the measuring point from single-path measurement to two-path measurement, an identical sensor must be selected.

Two-path measurement with FlowDC ⁴⁾

In the case of two-path measurement with FlowDC, the flow is measured by two measurements at the measuring point.

For this, the two sensor sets are installed on the measuring pipe, offset at a specific angle to one another (180° for 1 traverse, 90° for 2 traverses). This is independent of the rotation position of the two sensor sets on the measuring pipe.

The measured values of both sensor sets are averaged. Based on this average measurement value, the measured value is compensated depending on the type of disturbance and the distance from the measuring point to the disturbance point. This makes it possible to maintain the specified accuracy and repeatability for measurements in non-ideal conditions (e.g. short inlet runs), with inlet runs up to only 2x DN before and after the measuring point.

The configuration of the two measuring paths is only performed once and is adopted for both measuring paths.

2) Order code for "Mounting type", option A2 "Clamp-on, 2-channel, 2-sensor sets"

3) Order code for "Application package", option EN "FlowDC"

4) Flow disturbance compensation

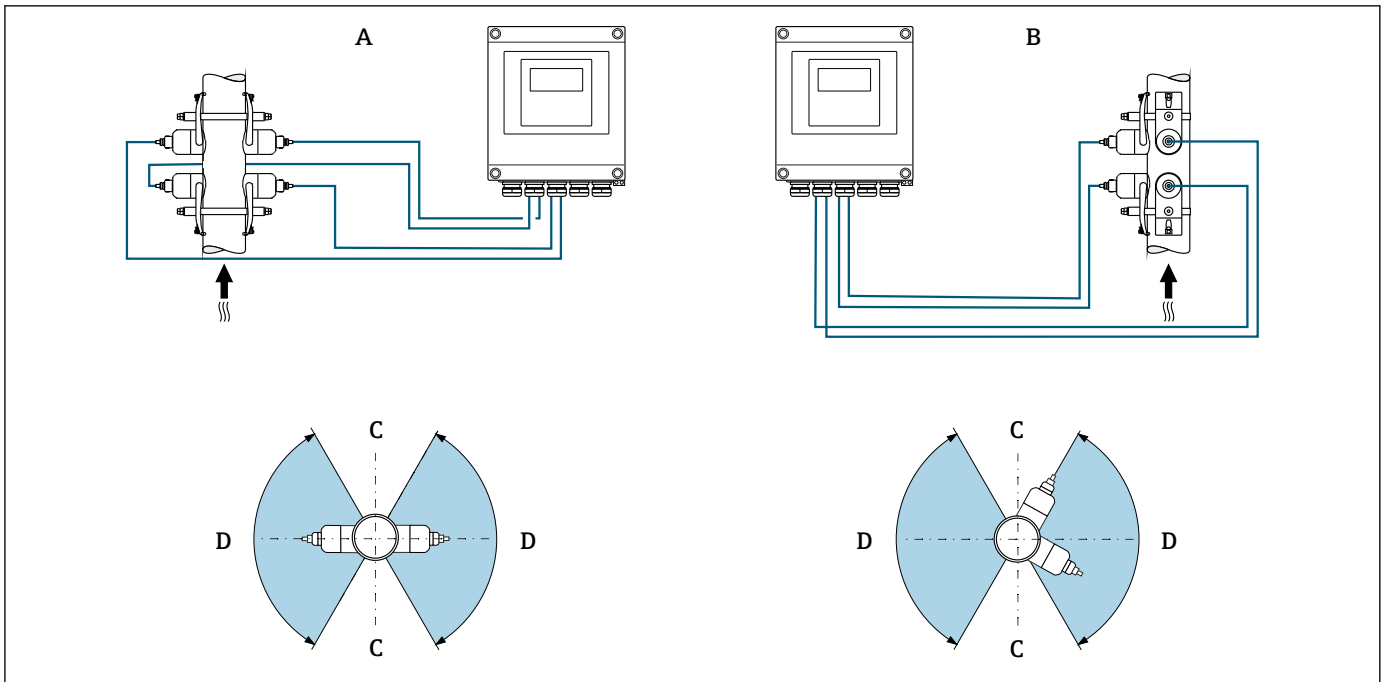

A0044944

8 Two-path measurement: examples for the horizontal arrangement of the sensor sets at a measuring point

- A Installation of the sensor sets for measurement via 1 traverse
- B Installation of the sensor sets for measurement via 2 traverses
- C Non-recommended installation range with horizontal orientation (60°)
- D Recommended installation range max. 120°

i If FlowDC is not used, it is necessary to adhere strictly to the specified inlet and outlet runs after disturbances in the measuring pipe (e.g. elbows, extensions, reductions) to obtain correct flow measured values.

Dimensions

i For the dimensions and installed lengths of the device, see the "Technical Information" document, "Mechanical construction" section

6.1.2 Sensor set selection and arrangement

i If mounting horizontally, always mount the sensor set so that it is offset at an angle of at least $\pm 30^\circ$ to the top of the measuring pipe to avoid incorrect measurements caused by empty space at the top of the pipe.

The sensors can be arranged in different ways:

- Mounting arrangement for measurement with 1 sensor set (1 measuring path):
 - The sensors are located on opposite sides of the pipe (offset by 180°): measurement with 1 or 3 traverses
 - The sensors are located on the same side of the pipe: measurement with 2 or 4 traverses
 - Mounting arrangement for measurement with 2 sensor sets (2 measuring paths):
 - 1 sensor of each sensor set is located on the opposite side of the pipe (offset by 180°): measurement with 1 or 3 traverses
 - The sensors are located on the same side of the pipe: measurement with 2 or 4 traverses
- The sensor sets are arranged on the pipe, offset by 90°.

i Using 5 MHz sensors

Here, the rails of the two sensor sets are always arranged at an angle of 180° to one another and connected by cables for all measurements with 1, 2, 3 or 4 traverses. The sensor functions are assigned in the two rails via the transmitter electronics unit depending on the selected number of traverses. It is not necessary to swap the cables in the transmitter between the channels.

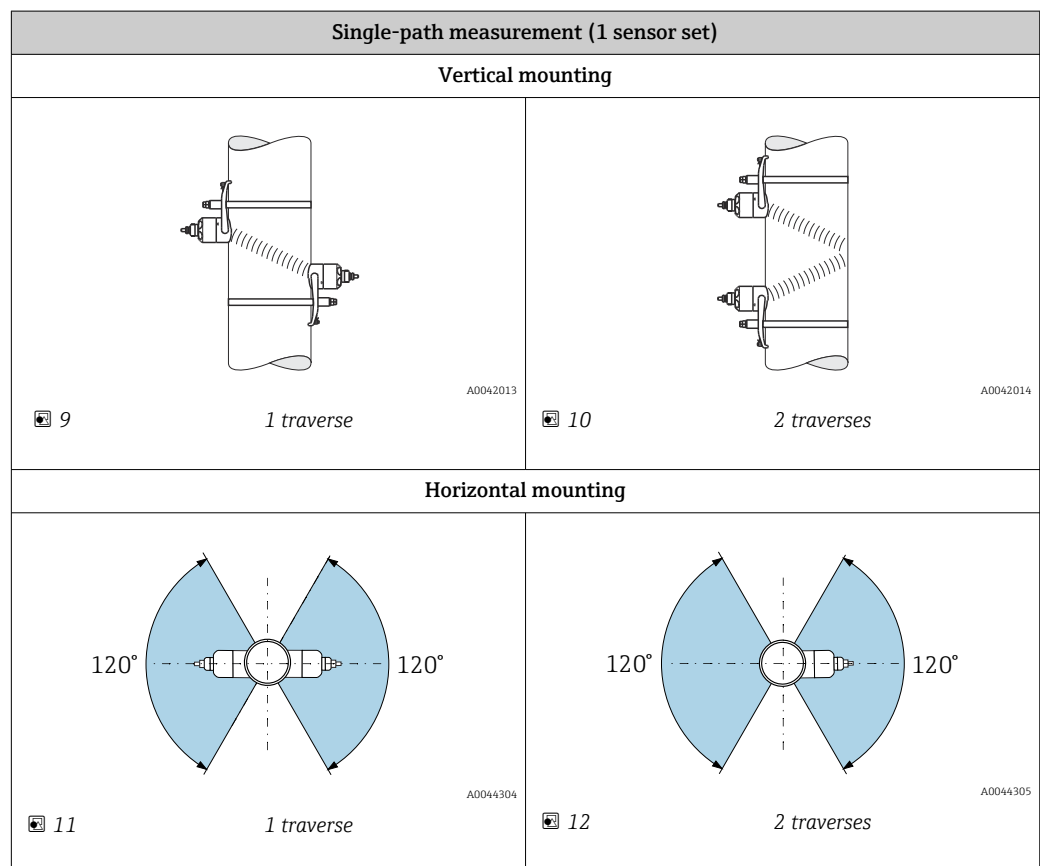

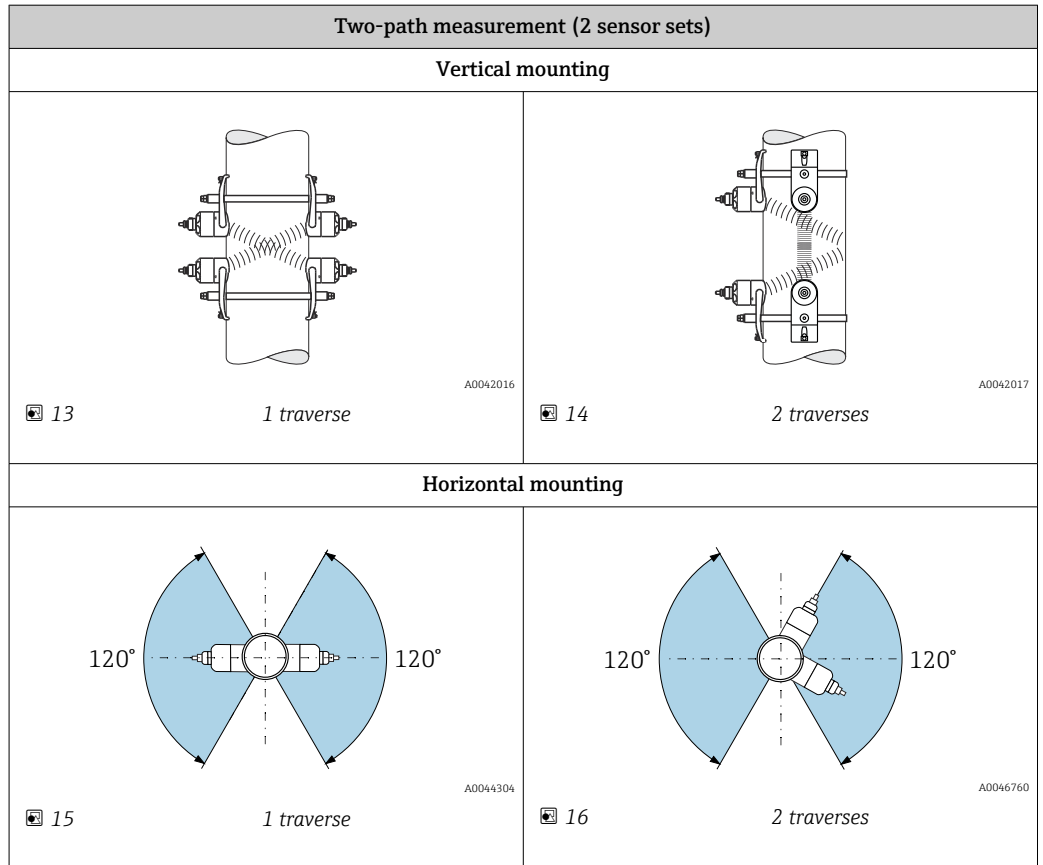

Operating frequency selection

The sensors of the measuring device are available with adapted operating frequencies. These frequencies are optimized for different properties of measuring pipes (material, pipe wall thickness) and media (kinematic viscosity) for the resonance behavior of the measuring pipes. If these properties are known, an optimum selection can be made according to the following tables⁵⁾. If these properties are not (completely) known, the sensors can be assigned as follows:

- 5 MHz for DN 15 to 65 (½ to 2½")
- 2 MHz for DN 50 to 300 (2 to 12")
- 1 MHz for DN 100 to 4000 (4 to 160")
- 0.5 MHz for DN 150 to 4000 (6 to 160")
- 0.3 MHz for DN 1000 to 4000 (40 to 160")

Measuring pipe material	Measuring pipe nominal diameter	Recommendation
Steel, cast iron	< DN 65 (2½")	C-500-A
	≥ DN 65 (2½")	See table "Measuring pipe material: steel, cast iron" → 26
Plastic	< DN 50 (2")	C-500-A
	≥ DN 50 (2")	See table "Measuring pipe material: plastic" → 26
Glass-fiber reinforced plastic	< DN 50 (2")	C-500-A (with restrictions)
	≥ DN 50 (2")	See table "Measuring pipe material: glass-fiber reinforced plastic" → 26

5) Recommendation: product design and sizing in Applicator → 149

Measuring pipe material: steel, cast iron

Pipe wall thickness [mm (in)]	Kinematic viscosity cSt [mm ² /s]		
	0 < ν ≤ 10	10 < ν ≤ 100	100 < ν ≤ 1000
	Transducer frequency (sensor version / number of traverses) ¹⁾		
1.0 to 1.9 (0.04 to 0.07)	2 MHz (C-200 / 2)	2 MHz (C-200 / 1)	2 MHz (C-200 / 1)
1.9 to 2.2 (0.07 to 0.09)	1 MHz (C-100 / 2)	1 MHz (C-100 / 1)	1 MHz (C-100 / 1)
2.2 to 2.8 (0.09 to 0.11)	2 MHz (C-200 / 2)	1 MHz (C-100 / 2)	1 MHz (C-100 / 1)
2.8 to 3.4 (0.11 to 0.13)	1 MHz (C-100 / 2)	1 MHz (C-100 / 1)	1 MHz (C-100 / 1)
3.4 to 4.2 (0.13 to 0.17)	2 MHz (C-200 / 2)	2 MHz (C-200 / 1)	1 MHz (C-100 / 1)
4.2 to 5.9 (0.17 to 0.23)	1 MHz (C-100 / 2)	1 MHz (C-100 / 1)	0.5 MHz (C-050 / 2)
5.9 to 10.0 (0.23 to 0.39)	2 MHz (C-200 / 2)	1 MHz (C-100 / 2)	0.5 MHz (C-050 / 2)
>10.0 (0.39)	1 MHz (C-100 / 2)	1 MHz (C-100 / 1)	0.5 MHz (C-050 / 1)

1) The table shows a typical selection. In critical situations, the optimum sensor type may differ from these recommendations.

Measuring pipe material: plastic

Nominal diameter [mm (")]	Kinematic viscosity cSt [mm ² /s]		
	0 < ν ≤ 10	10 < ν ≤ 100	100 < ν ≤ 1000
	Transducer frequency (sensor version / number of traverses) ¹⁾		
15 to 50 (½ to 2)	5 MHz (C-500 / 2)	5 MHz (C-500 / 2)	5 MHz (C-500 / 2)
50 to 80 (2 to 3)	2 MHz (C-200 / 2)	1 MHz (C-100 / 2)	0.5 MHz (C-050 / 2)
80 to 150 (3 to 6)	1 MHz (C-100 / 2)	1 MHz (C-100 / 2)	0.5 MHz (C-050 / 2)
150 to 200 (6 to 8)	1 MHz (C-100 / 2)	0.5 MHz (C-050 / 2)	0.5 MHz (C-050 / 2)
200 to 300 (8 to 12)	1 MHz (C-100 / 2)	0.5 MHz (C-050 / 2)	0.5 MHz (C-050 / 2)
300 to 400 (12 to 16)	1 MHz (C-100 / 1)	0.5 MHz (C-050 / 2)	0.5 MHz (C-050 / 1)
400 to 500 (16 to 20)	1 MHz (C-100 / 1)	0.5 MHz (C-050 / 1)	0.5 MHz (C-050 / 1)
500 to 1000 (20 to 40)	0.5 MHz (C-050 / 1)	0.5 MHz (C-050 / 1)	-
1000 to 4000 (40 to 160)	0.3 MHz (C-030 / 1)	-	-

1) The table shows a typical selection. In critical situations, the optimum sensor type may differ from these recommendations.

Measuring pipe material: glass-fiber reinforced plastic

Nominal diameter [mm (")]	Kinematic viscosity cSt [mm ² /s]		
	0 < ν ≤ 10	10 < ν ≤ 100	100 < ν ≤ 1000
	Transducer frequency (sensor version / number of traverses) ¹⁾		
15 to 50 (½ to 2)	5 MHz (C-500 / 2)	5 MHz (C-500 / 2)	5 MHz (C-500 / 2)
50 to 80 (2 to 3)	1 MHz (C-100 / 2)	0.5 MHz (C-050 / 2)	0.5 MHz (C-050 / 1)
80 to 150 (3 to 6)	1 MHz (C-100 / 2)	0.5 MHz (C-050 / 1)	0.5 MHz (C-050 / 1)
150 to 200 (6 to 8)	0.5 MHz (C-050 / 2)	0.5 MHz (C-050 / 1)	-
200 to 300 (8 to 12)	0.5 MHz (C-050 / 2)	0.5 MHz (C-050 / 1)	-
300 to 400 (12 to 16)	0.5 MHz (C-050 / 2)	0.5 MHz (C-050 / 1)	-
400 to 500 (16 to 20)	0.5 MHz (C-050 / 1)	-	-

Nominal diameter [mm (")]	Kinematic viscosity cSt [mm ² /s]		
	0 < ν ≤ 10	10 < ν ≤ 100	100 < ν ≤ 1000
	Transducer frequency (sensor version / number of traverses) ¹⁾		
500 to 1000 (20 to 40)	0.5 MHz (C-050 / 1)	–	–
1000 to 4000 (40 to 160)	0.3 MHz (C-030 / 1)	–	–

1) The table shows a typical selection. In critical situations, the optimum sensor type may differ from these recommendations.

-  If clamp-on sensors are used, a 2 traverse-type installation is recommended. This is the easiest and most convenient type of installation, particularly for measuring devices whose pipe can only be accessed with difficulty from one side.
- A 1 traverse installation is recommended for the following installation conditions:
 - Certain plastic pipes with a wall thickness >4 mm (0.16 in)
 - Pipes made of composite materials (e.g. glass-fiber reinforced plastic)
 - Lined pipes
 - Applications with media with high acoustic damping

6.1.3 Environment and process requirements

Ambient temperature range

Transmitter	–40 to +60 °C (–40 to +140 °F)
Readability of the local display	–20 to +60 °C (–4 to +140 °F) The readability of the display may be impaired at temperatures outside the temperature range.
Sensor	DN 15 to 65 (½ to 2½") –40 to +130 °C (–40 to +266 °F) DN 50 to 4000 (2 to 160") ▪ Standard: –20 to +80 °C (–4 to +176 °F) ▪ Optional: –40 to +130 °C (–40 to +266 °F)
Sensor cable (connection between transmitter and sensor)	DN 15 to 65 (½ to 2½") Standard (TPE): –40 to +80 °C (–40 to +176 °F) DN 50 to 4000 (2 to 160") ▪ Standard (TPE halogen-free): –40 to +80 °C (–40 to +176 °F) ▪ Optional (PTFE): –40 to +130 °C (–40 to +266 °F)

 In principle, it is permitted to insulate the sensors mounted on the pipe. In the case of insulated sensors, make sure that the process temperature does not exceed or drop below the specified cable temperature.

- ▶ If operating outdoors:
Avoid direct sunlight, particularly in warm climatic regions.

Medium pressure range

No pressure limitation. Nevertheless, for correct measurement, the static pressure of the medium must be higher than the vapor pressure.

6.1.4 Special mounting instructions

Display guard

- ▶ To ensure that the display guard can be easily opened, maintain the following minimum head clearance: 350 mm (13.8 in)

6.2 Mounting the measuring device

6.2.1 Required tools

For transmitter

- Torque wrench
- For wall mounting:
 - Open-ended wrench for hexagonal screw max. M5
- For pipe mounting:
 - Open-ended wrench AF 8
 - Phillips head screwdriver PH 2

For sensor

For installation on the measuring pipe: use a suitable mounting tool

6.2.2 Preparing the measuring device

1. Remove all remaining transport packaging.
2. Remove stick-on label on the electronics compartment cover.

6.2.3 Mounting the sensor

WARNING

Risk of injury when mounting the sensors and strapping bands!

- ▶ Due to the increased risk of cuts, wear suitable gloves and protective goggles.

Sensor configuration and settings

DN 15 to 65 (½ to 2½")	DN 50 to 4000 (2 to 160")			
	Strapping band		Welded bolt	
	2 traverses [mm (in)]	1 traverse [mm (in)]	2 traverses [mm (in)]	1 traverse [mm (in)]
Sensor distance ¹⁾	Sensor distance ¹⁾	Sensor distance ¹⁾	Sensor distance ¹⁾	Sensor distance ¹⁾
–	Wire length →  36	Measuring rail ^{1) 2)}	Wire length	Measuring rail ^{1) 2)}

- 1) Depends on the conditions at the measuring point (measuring pipe, medium etc.). The dimension can be determined via FieldCare or Applicator. See also the **Result sensor distance / measuring aid** parameter in the **Measuring point** submenu
- 2) Only up to DN 600 (24")

Determining the sensor mounting positions

Sensor holder with U-shaped screws

-  Can be used for
 - Measuring devices with measuring range DN 15 to 65 (½ to 2½")
 - Mounting on pipes DN 15 to 32 (½ to 1¼")

Procedure:

1. Disconnect the sensor from the sensor holder.
2. Position the sensor holder on the measuring pipe.
3. Fit the U-shaped screws through the sensor holder and lightly grease the thread.
4. Screw the nuts onto the U-shaped screws.

5. Position the sensor holder correctly and tighten the nuts uniformly.

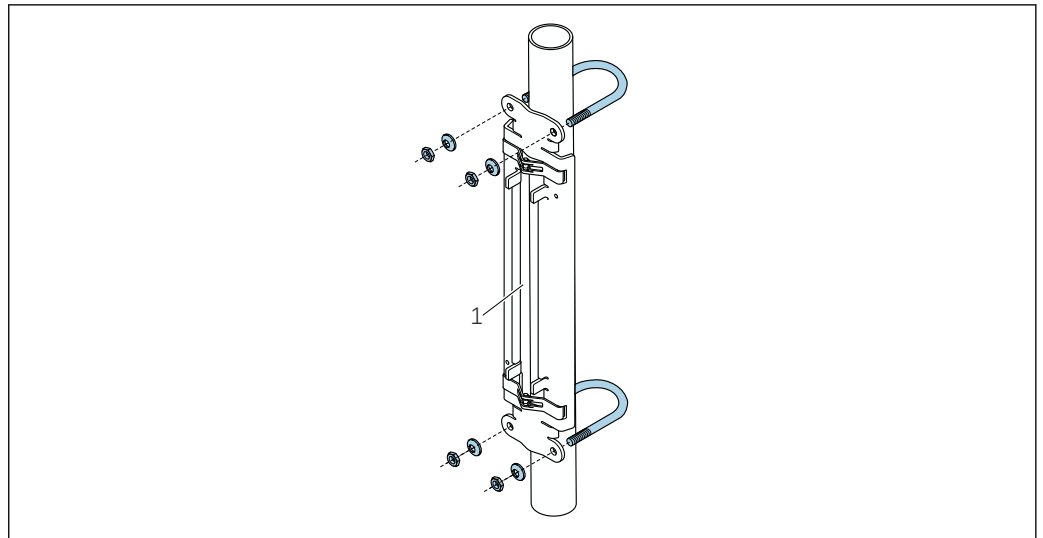

A0043369

17 Holder with U-shaped screws

1 Sensor holder

CAUTION

Risk of damaging plastic or glass pipes if the nuts on the U-shaped screws are tightened too much!

- ▶ The use of a metal half-shell (on the opposite side of the sensor) is recommended for plastic or glass pipes.

- i** The visible measuring pipe surface must be clean (free from flaking paint and/or rust) to ensure good acoustic contact.

Sensor holder with strapping bands (small nominal diameters)

- i** Can be used for
 - Measuring devices with measuring range DN 15 to 65 (½ to 2½")
 - Mounting on pipes DN > 32 (1¼")

Procedure:

1. Disconnect the sensor from the sensor holder.
2. Position the sensor holder on the measuring pipe.

3. Wrap the strapping bands around the sensor holder and measuring pipe without twisting them.

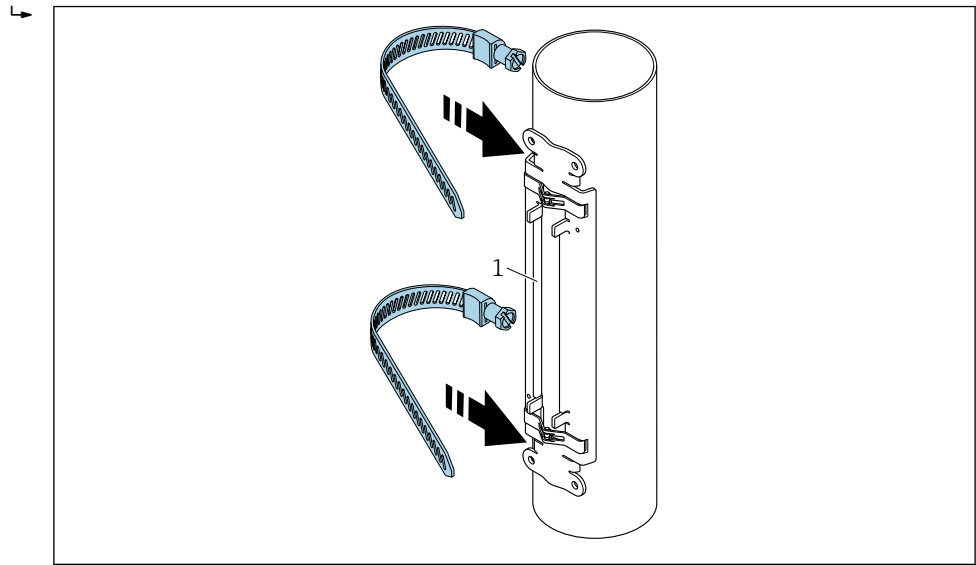

A0043371

18 Positioning the sensor holder and mounting the strapping bands

1 Sensor holder

4. Guide the strapping bands through the strapping band locks.
5. Tighten the strapping bands as tightly as possible by hand.
6. Set the sensor holder to the desired position.
7. Push down the tensioning screw and tighten the strapping bands so they cannot slip.

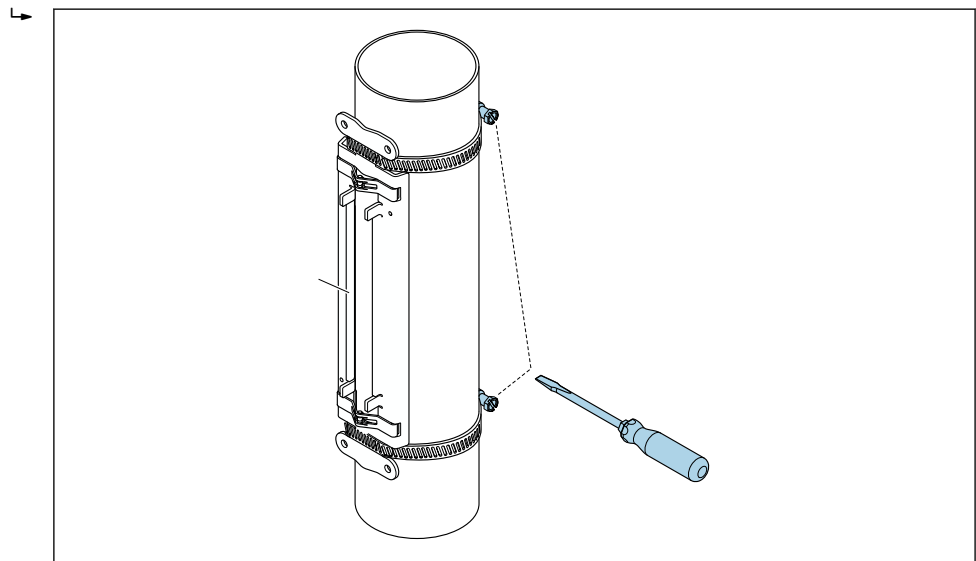

A0043372

19 Tightening the tensioning screws of the strapping bands

8. If necessary, shorten the strapping bands and trim the cut edges.

⚠ WARNING

Risk of injury!

- ▶ To avoid sharp edges, trim the cut edges after shortening the strapping bands. Wear suitable gloves and protective goggles.

- i** The visible measuring pipe surface must be clean (free from flaking paint and/or rust) to ensure good acoustic contact.

Sensor holder with strapping bands (medium nominal diameters)

- i** Can be used for
- Measuring devices with measuring range DN 50 to 4000 (2 to 160")
 - Mounting on pipes DN ≤ 600 (24")

Procedure:

1. Fit the mounting bolt over strapping band 1.
2. Position strapping band 1 as perpendicular as possible to the measuring pipe axis without twisting it.
3. Guide the end of strapping band 1 through the strapping band lock.
4. Tighten strapping band 1 as tightly as possible by hand.
5. Set strapping band 1 to the desired position.
6. Push down the tensioning screw and tighten strapping band 1 so it cannot slip.
7. Strapping band 2: proceed as for strapping band 1 (steps 1 to 6).
8. Only slightly tighten strapping band 2 for final mounting. It must be possible to move strapping band 2 for final alignment.
9. If necessary, shorten both strapping bands and trim the cut edges.

⚠ WARNING**Risk of injury!**

- To avoid sharp edges, trim the cut edges after shortening the strapping bands. Wear suitable gloves and protective goggles.

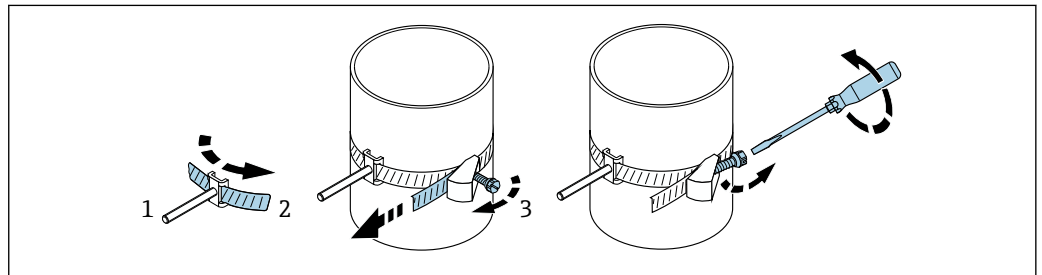

A0043373

20 Holder with strapping bands (medium nominal diameters), with hinged screw

- 1 Mounting bolts
- 2 Strapping band
- 3 Tensioning screw

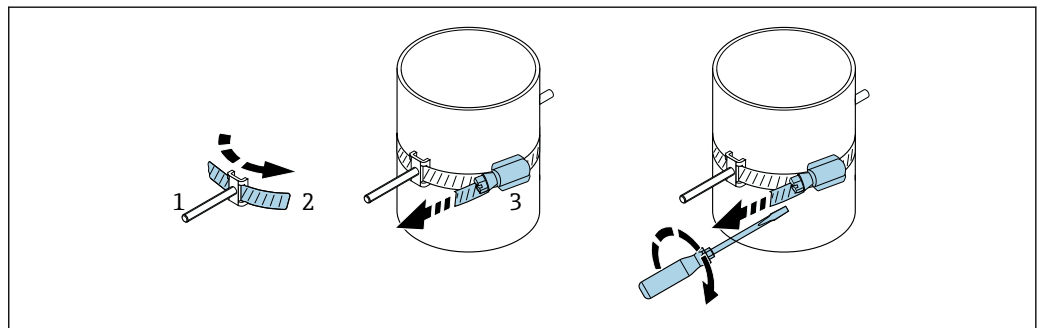

A0044350

21 Holder with strapping bands (medium nominal diameters), without hinged screw

- 1 Mounting bolts
- 2 Strapping band
- 3 Tensioning screw

Sensor holder with strapping bands (large nominal diameters)

- i** Can be used for
- Measuring devices with measuring range DN 50 to 4000 (2 to 160")
 - Mounting on pipes DN > 600 (24")
 - 1-traverse mounting or 2-traverse mounting with 180° arrangement
 - 2-traverse mounting with two-path measurement and 90° arrangement (instead of 180°)

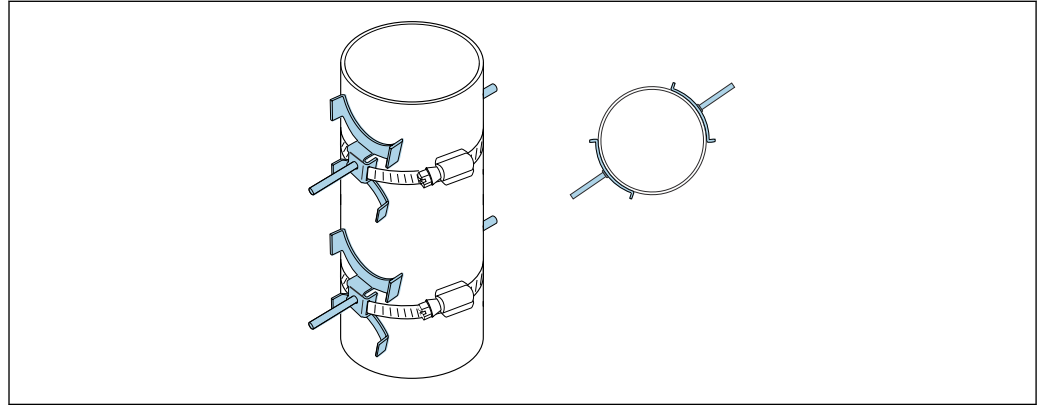

A004668

Procedure:

1. Measure the pipe circumference. Note down the full/half or quarter circumference.
2. Cut the strapping bands to length (= pipe circumference + 30 mm (1.18 in)) and trim the cut edges.
3. Select the mounting location of the sensors with the given sensor distance and optimum inlet run conditions, while ensuring there is nothing impeding sensor mounting over the entire circumference of the measuring pipe.
4. Fit two strap bolts over strapping band 1 and guide approx. 50 mm (2 in) of one of the strapping band ends through one of the two strapping band locks and into the buckle. Then guide the protective flap over this strapping band end and lock in place.
5. Position strapping band 1 as perpendicular as possible to the measuring pipe axis without twisting it.
6. Guide the second strapping band end through the strapping band lock that is still free and proceed in the same way as for the first strapping band end. Guide the protective flap over the second strapping band end and lock in place.
7. Tighten strapping band 1 as tightly as possible by hand.
8. Set strapping band 1 to the desired position, ensuring that it is as perpendicular as possible to the measuring pipe axis.
9. Position the two strap bolts on strapping band 1, arranging them at a half circumference in relation to one another (180° arrangement, e.g. clock hands positioned at 7:30 and 1:30) or quarter circumference (90° arrangement, e.g. clock hands positioned at 10 o'clock and 7 o'clock).
10. Tighten strapping band 1 so that it cannot slip.
11. Strapping band 2: proceed as for strapping band 1 (steps 4 to 8).
12. Only slightly tighten strapping band 2 for final mounting so that it can still be adjusted. The distance/offset from the center of strapping band 2 to the center of strapping band 1 is indicated by the sensor distance of the device.
13. Align strapping band 2 so that it is perpendicular to the measuring pipe axis and parallel to strapping band 1.

14. Position the two strap bolts on strapping band 2 on the measuring pipe so they are parallel to one another and offset at the same height/clock position (e.g. 10 and 4 o'clock) in relation to the two strap bolts on strapping band 1. A line drawn on the measuring pipe wall that is parallel to the measuring pipe axis can be helpful here. Now set the distance between the center of the strap bolts at the same level so that it exactly matches the sensor distance. An alternative method is to use the wire length → 36.
15. Tighten strapping band 2 so that it cannot slip.

⚠ WARNING

Risk of injury!

- To avoid sharp edges, trim the cut edges after shortening the strapping bands. Wear suitable gloves and protective goggles.

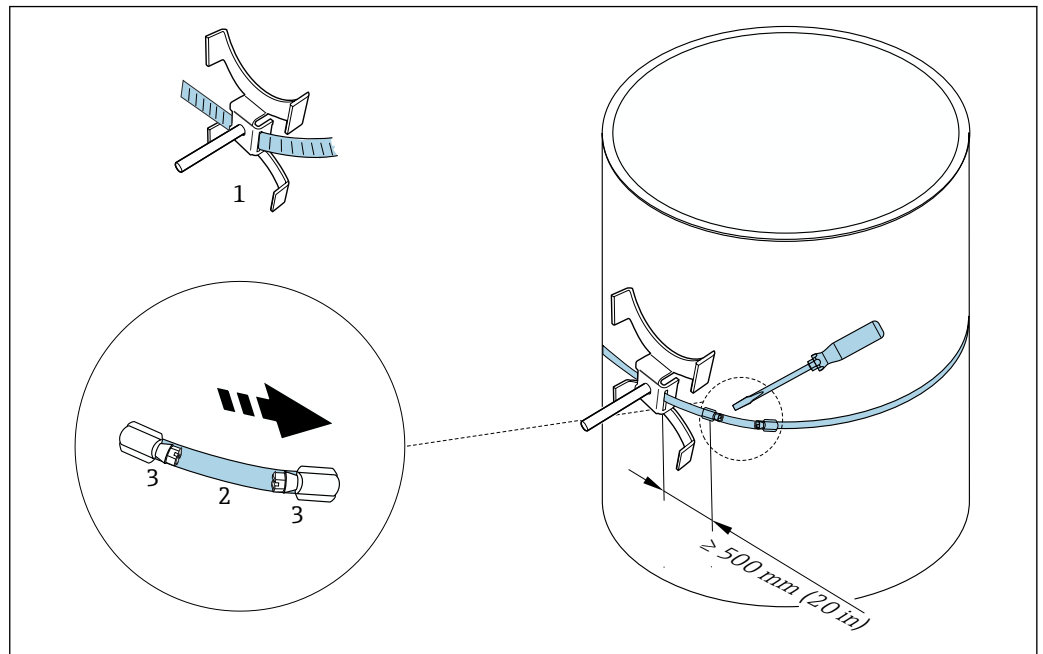

22 Holder with strapping bands (large nominal diameters)

- 1 Strap bolt with guide*
 2 Strapping band*
 3 Tensioning screw

*The distance between the strap bolt and strapping band lock must be at least 500 mm (20 in).

- i** ■ For 1-traverse mounting with 180° (opposite) → 11, 24 (single-path measurement, A0044304), → 15, 25 (two-path measurement, A0043168)
 ■ For 2-traverse mounting → 12, 24 (single-path measurement, A0044305), → 16, 25 (two-path measurement, A0043309)
 ■ Electrical connection

Sensor holder with welded bolts

- i** Can be used for
 ■ Measuring devices with measuring range DN 50 to 4000 (2 to 160")
 ■ Mounting on pipes DN 50 to 4000 (2 to 160")

Procedure:

- The welded bolts must be fixed at the same installation distances as the mounting bolts with strapping bands. The following sections explain how to align the mounting bolts, depending on the mounting method and measurement method:
 - Installation for measurement via 1 traverse → 36
 - Installation for measurement via 2 traverses → 38
- The sensor holder is secured as standard with a locking nut with a metric M6 ISO thread. If another thread should be used for fastening purposes, a sensor holder with a detachable locking nut must be used.

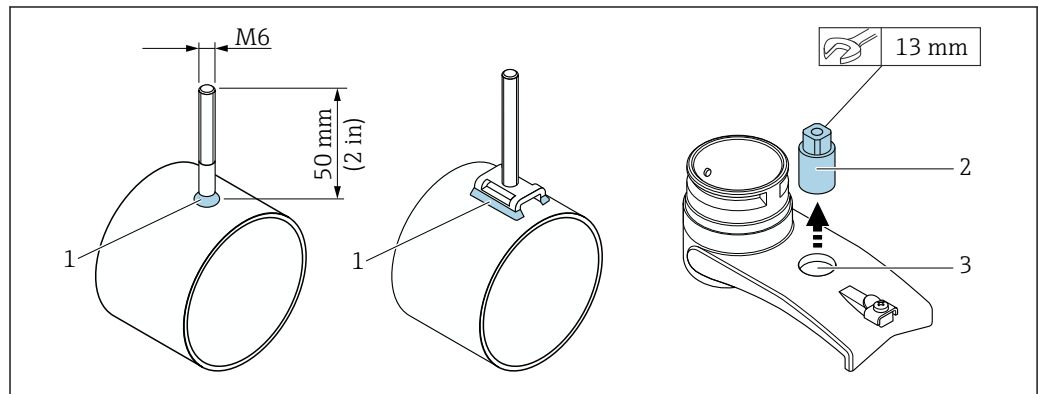

23 Holder with welded bolts

- 1 Welding seam
- 2 Locking nut
- 3 Hole diameter max. 8.7 mm (0.34 in)

Sensor installation – small nominal diameters DN 15 to 65 (½ to 2½")

Requirements

- The installation clearance is known → 28
- The sensor holder is pre-installed

Material

The following material is required for mounting:

- Sensor incl. adapter cable
- Sensor cable for connecting to the transmitter
- Coupling medium (coupling pad or coupling gel) for an acoustic connection between the sensor and pipe

Procedure:

1. Set the distance between the sensors to the value determined for the sensor distance. Press the movable sensor down slightly to move it.

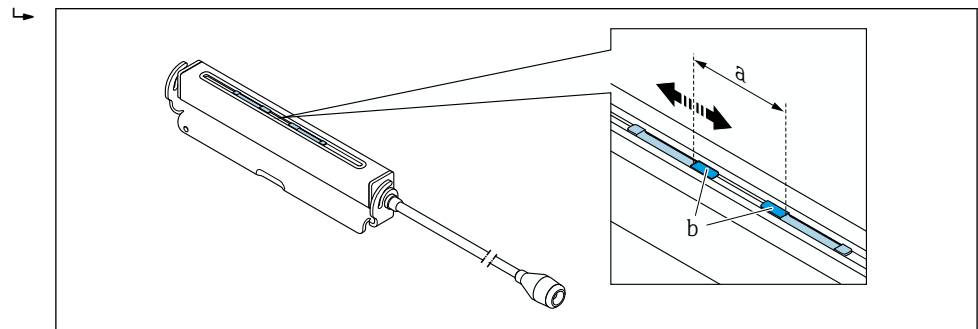

24 Distance between sensors as per the installation clearance → 28

- a Sensor distance (back of sensor must touch the surface)
- b Sensor contact surfaces

2. Stick the coupling pad under the sensor to the measuring pipe or coat the contact surfaces of the sensor (b) with an even layer of coupling gel (approx. 0.5 to 1 mm (0.02 to 0.04 in)).
3. Fit the sensor housing on the sensor holder.

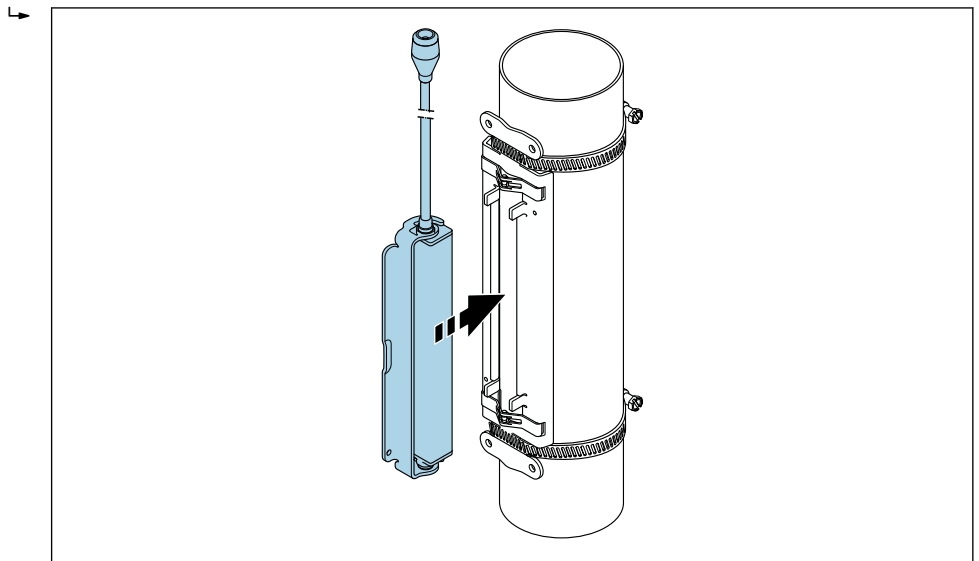

A0043377

25 Fitting the sensor housing

4. Lock the bracket in place to fix the sensor housing on the sensor holder.

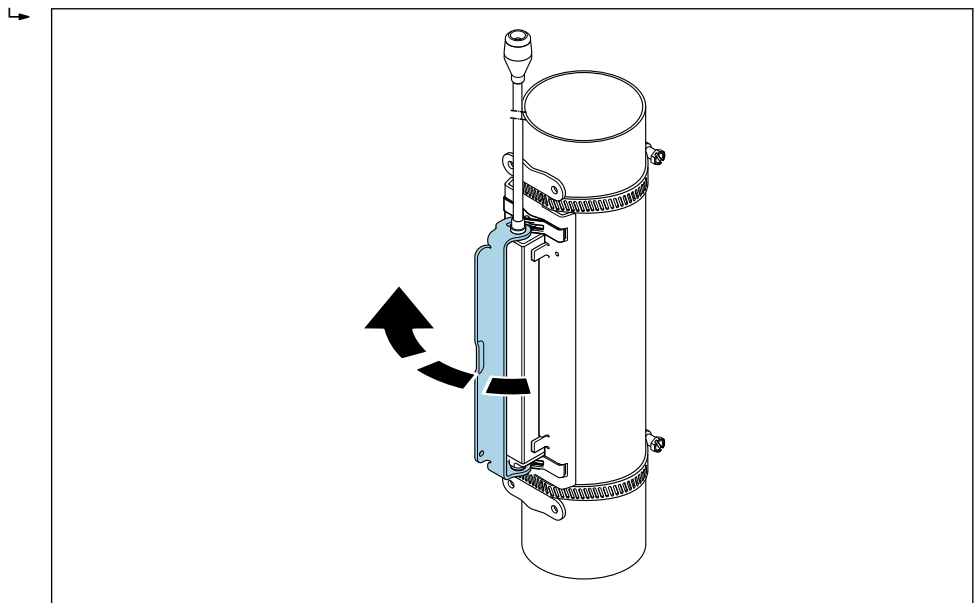

A0043378

26 Fixing the sensor housing

5. Connect the sensor cable to the adapter cable.
 - ↳ This completes the mounting procedure. The sensors can now be connected to the transmitter via the connecting cables.
- i** The visible measuring pipe surface must be clean (free from flaking paint and/or rust) to ensure good acoustic contact.
 - If necessary, the holder and sensor housing can be secured with a screw/nut or a lead seal (not supplied).
 - The bracket can only be released using an auxiliary tool (e.g. screwdriver).

Sensor installation – medium/large nominal diameters DN 50 to 4000 (2 to 160")



Installation for measurement via 1 traverse

Requirements

- The installation clearance and wire length are known →  28
- Strapping bands are pre-installed

Material

The following material is required for mounting:

- Two strapping bands incl. mounting bolts and centering plates where necessary (already pre-installed →  31, →  32)
- Two measuring wires, each with a cable lug and a fixer to fix the strapping bands
- Two sensor holders
- Coupling medium (coupling pad or coupling gel) for an acoustic connection between the sensor and pipe
- Two sensors incl. connecting cables

 Installation is unproblematic up to DN 400 (16"), as of DN 400 (16") check the distance and angle (180°) diagonally with the wire length.

Procedure:

1. Prepare the two measuring wires: arrange the cable lugs and fixer such that the distance they are apart corresponds to the wire length (SL). Screw the fixer onto the measuring wire.

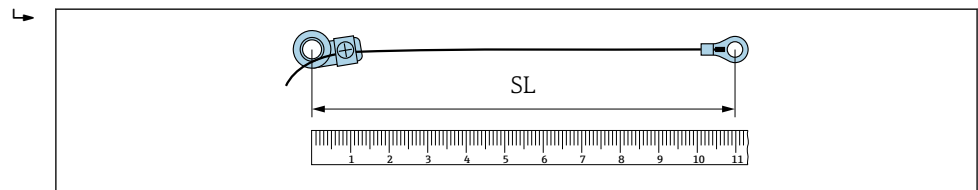

A0043379

 27 Fixer and cable lugs at a distance that corresponds to the wire length (SL)

2. With measuring wire 1: fit the fixer over the mounting bolt of strapping band 1 that is already securely mounted. Run measuring wire 1 clockwise around the measuring pipe. Fit the cable lug over the mounting bolt of strapping band 2 that can still be moved.
3. With measuring wire 2: fit the cable lug over the mounting bolt of strapping band 1 that is already securely mounted. Run measuring wire 2 counterclockwise around the measuring pipe. Fit the fixer over the mounting bolt of strapping band 2 that can still be moved.

4. Take the still movable strapping band 2, incl. the mounting bolt, and move it until both measuring wires are evenly tensioned and then tighten strapping band 2 so that it cannot slip. Then check the sensor distance from the center of the strapping bands. If the distance is too small, release strapping band 2 again and position it better. Both strapping bands should be as perpendicular as possible to the measuring pipe axis and parallel to one another.

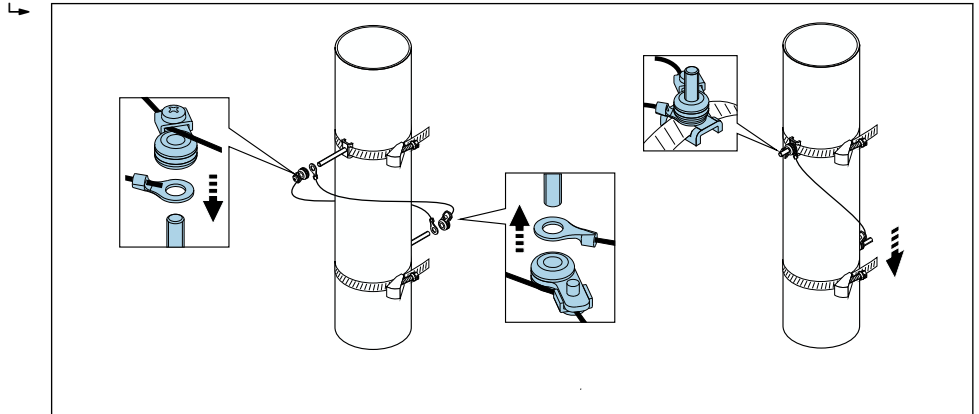

28 Positioning the strapping bands (steps 2 to 4)

5. Loosen the screws of the fixers on the measuring wires and remove the measuring wires from the mounting bolt.
6. Fit the sensor holders over the individual mounting bolts and tighten securely with the locking nut.

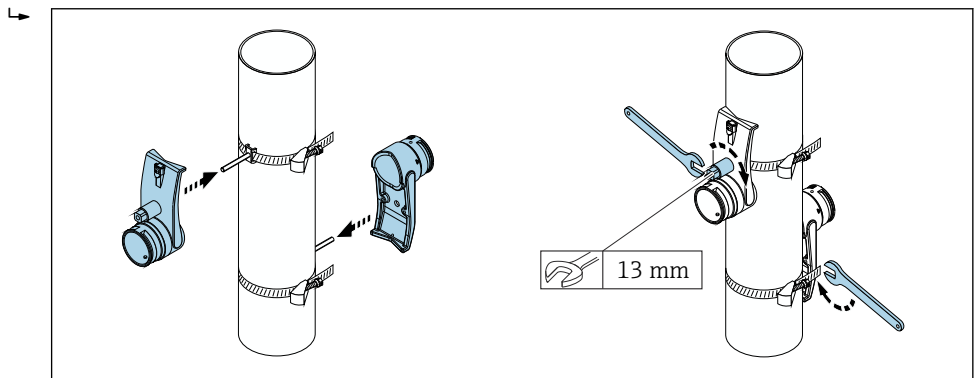

29 Mounting the sensor holders

7. Apply the coupling pad to the sensors with the adhesive side facing down (→ 167). Alternatively coat the contact surfaces with an even layer of coupling gel (approx. 1 mm (0.04 in)). going from the groove through the center to the opposite edge.

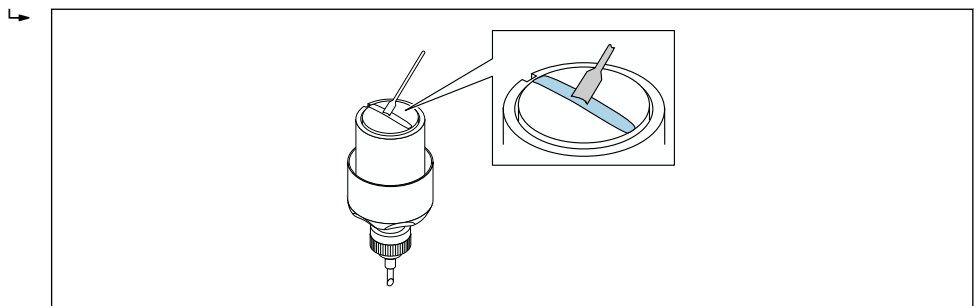

30 Coating the contact surfaces of the sensor with coupling gel (if there is no coupling pad)

8. Insert the sensor into the sensor holder.
9. Fit the sensor cover on the sensor holder and turn until the sensor cover engages with a click and the arrows (▲ / ▼ "close") are pointing towards one another.

10. Insert the sensor cable into the sensor until the end stop.

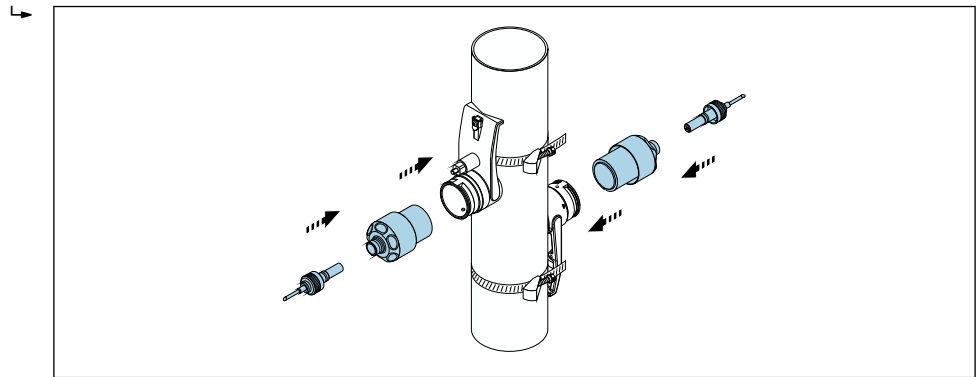

31 Mounting the sensor and connecting the sensor cable

The sensors can now be connected to the transmitter via the sensor cables and the error message can be checked in the sensor check function. This completes the mounting procedure.

- i
 - The visible measuring pipe surface must be clean (free from flaking paint and/or rust) to ensure good acoustic contact.
 - If the sensor is removed from the measuring pipe, it must be cleaned and new coupling gel applied (if there is no coupling pad).
 - On rough measuring pipe surfaces, the gaps in the rough surface must be filled with sufficient amounts of coupling gel if the use of the coupling pad does not suffice (installation quality check).

Installation for measurement via 2 traverses

Requirements

- The installation clearance is known → 28
- Strapping bands are pre-installed

Material

The following material is required for mounting:

- Two strapping bands incl. mounting bolts and centering plates where necessary (already pre-installed → 31, → 32)
- A mounting rail to position the strapping bands:
 - Short rail up to DN 200 (8")
 - Long rail up to DN 600 (24")
 - No rail > DN 600 (24"), as distance measured by sensor distance between the mounting bolts
- Two mounting rail holders
- Two sensor holders
- Coupling medium (coupling pad or coupling gel) for an acoustic connection between the sensor and pipe
- Two sensors incl. connecting cables
- Open-ended wrench (13 mm)
- Screwdriver

Procedure:

1. Position the strapping bands using the mounting rail [only DN50 to 600 (2 to 24"), for larger nominal diameters, measure the distance between the center of the strap bolts directly]: Fit the mounting rail with the bore identified by the letter (from the **Result sensor distance / measuring aid** parameter) over the mounting bolt of strapping band 1 that is fixed in place. Position the adjustable strapping band 2 and fit the mounting rail with the bore identified by the numerical value over the mounting bolt.

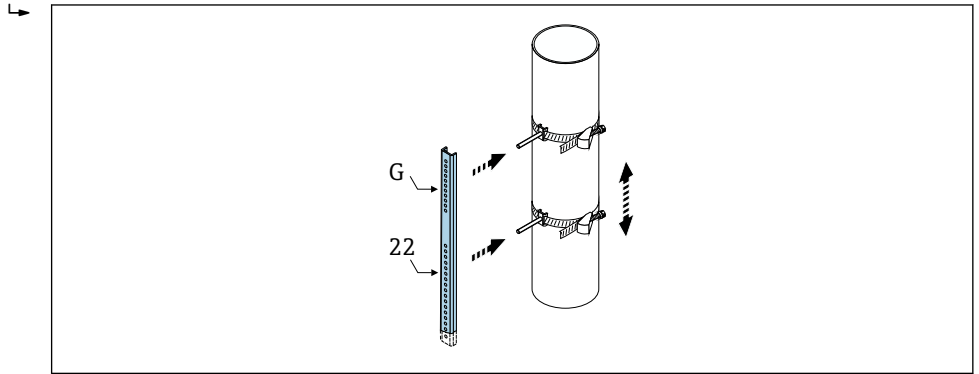

32 Determining the distance according to the mounting rail (e.g. G22)

2. Tighten strapping band 2 so that it cannot slip.
3. Remove the mounting rail from the mounting bolt.
4. Fit the sensor holders over the individual mounting bolts and tighten securely with the locking nut.
5. Apply the coupling pad to the sensors with the adhesive side facing down (→ 167). Alternatively coat the contact surfaces with an even layer of coupling gel (approx. 1 mm (0.04 in)), going from the groove through the center to the opposite edge.

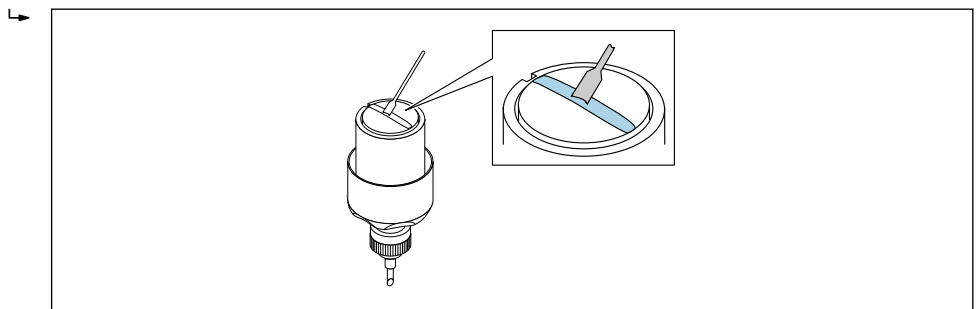

33 Coating the contact surfaces of the sensor with coupling gel (if there is no coupling pad)

6. Insert the sensor into the sensor holder.
7. Fit the sensor cover on the sensor holder and turn until the sensor cover engages with a click and the arrows (▲ / ▼ "close") are pointing towards one another.

8. Insert the sensor cable into the sensor until the end stop and tighten the union nut.

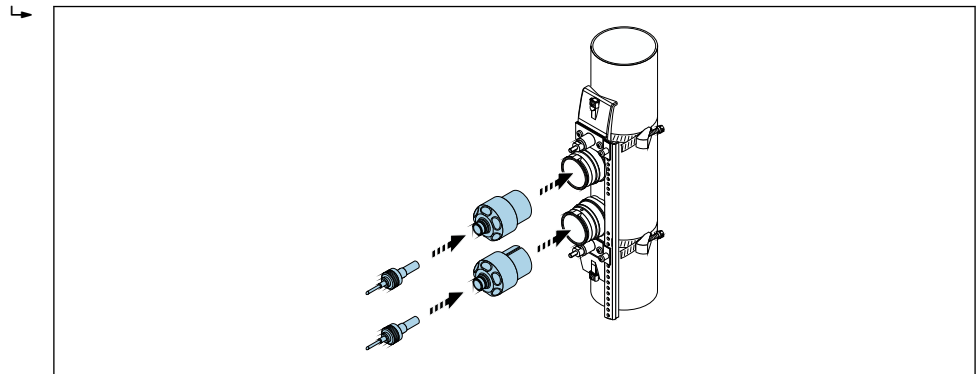

34 Mounting the sensor and connecting the sensor cable

The sensors can now be connected to the transmitter via the sensor cables and the error message can be checked in the sensor check function. This completes the mounting procedure.

- i**
 - The visible measuring pipe surface must be clean (free from flaking paint and/or rust) to ensure good acoustic contact.
 - If the sensor is removed from the measuring pipe, it must be cleaned and new coupling gel applied (if there is no coupling pad).
 - On rough measuring pipe surfaces, the gaps in the rough surface must be filled with sufficient amounts of coupling gel if the use of the coupling pad does not suffice (installation quality check).

6.2.4 Mounting the transmitter

CAUTION

Ambient temperature too high!

Danger of electronics overheating and housing deformation.

- ▶ Do not exceed the permitted maximum ambient temperature → 27.
- ▶ If operating outdoors: Avoid direct sunlight and exposure to weathering, particularly in warm climatic regions.

CAUTION

Excessive force can damage the housing!

- ▶ Avoid excessive mechanical stress.

The transmitter of the remote version can be mounted in the following ways:

- Wall mounting
- Pipe mounting

Wall mounting

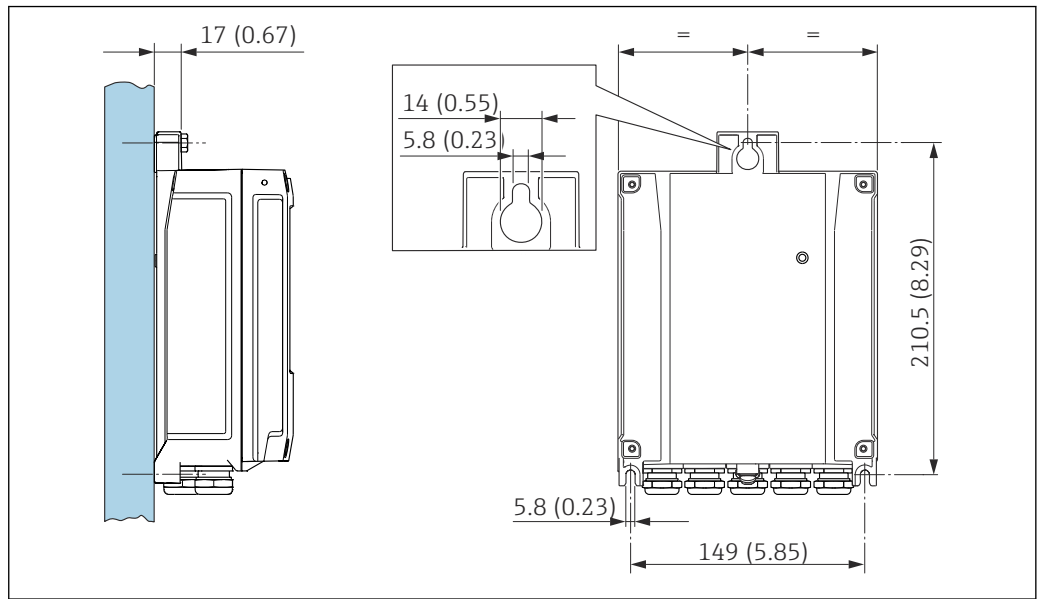

35 Engineering unit mm (in)

1. Drill the holes.
2. Insert wall plugs into the drilled holes.
3. Screw the securing screws in slightly.
4. Fit the transmitter housing over the securing screws and mount in place.
5. Tighten the securing screws.

Post mounting

WARNING

Excessive tightening torque applied to the fixing screws!

Risk of damaging the plastic transmitter.

► Tighten the fixing screws as per the tightening torque: 2 Nm (1.5 lbf ft)

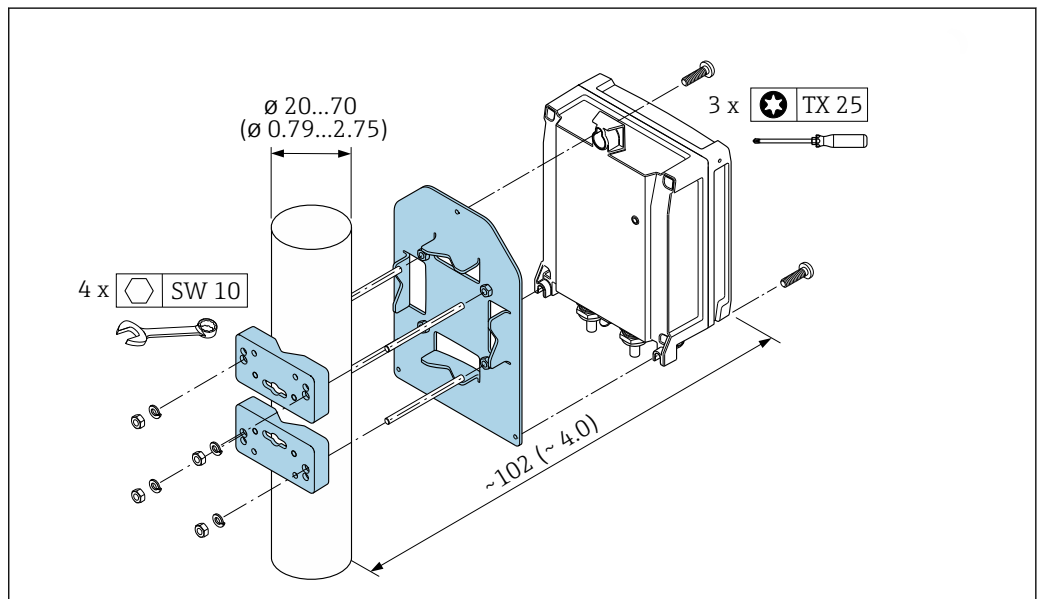

36 Engineering unit mm (in)

6.2.5 Turning the display module

The display module can be turned to optimize display readability and operability.

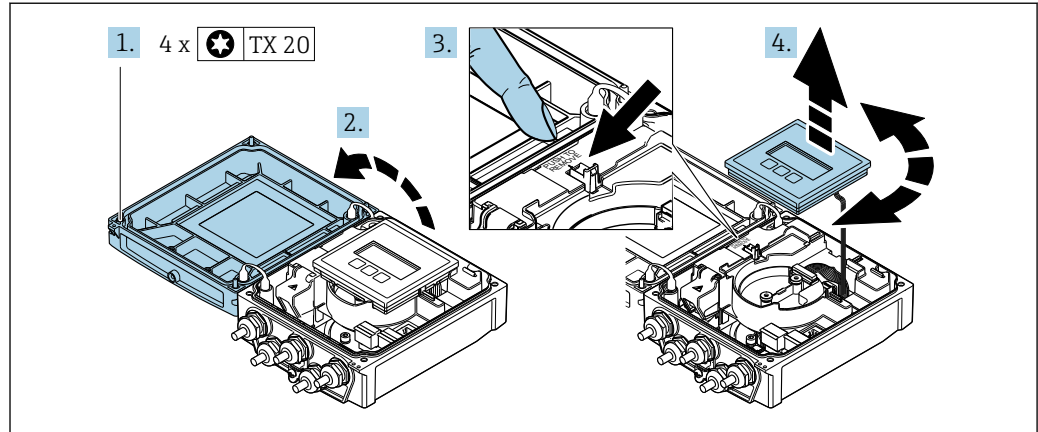

1. Loosen the fixing screws of the housing cover.
2. Open the housing cover.
3. Unlock the display module.
4. Pull out the display module and turn it to the desired position in increments of 90°.

Mounting the transmitter housing

⚠ WARNING

Excessive tightening torque applied to the fixing screws!

Damage to the transmitter.

- Tighten the fixing screws with the specified torques.

1. Insert the display module and lock it when doing so.
2. Close the housing cover.
3. Tighten the fixing screws of the housing cover: tightening torque for aluminum housing 2.5 Nm (1.8 lbf ft) – plastic housing 1 Nm (0.7 lbf ft).

6.3 Post-mounting check

Is the device undamaged (visual inspection)?	<input type="checkbox"/>
Does the measuring device meet the measuring point specifications? For example: <ul style="list-style-type: none"> ▪ Process temperature → 158 ▪ Inlet run conditions ▪ Ambient temperature ▪ Measuring range 	<input type="checkbox"/>
Has the correct orientation for the sensor been selected → 20? <ul style="list-style-type: none"> ▪ According to sensor type ▪ According to medium temperature ▪ According to medium properties (outgassing, with entrained solids) 	<input type="checkbox"/>
Are the sensors correctly connected to the transmitter (upstream/downstream) ?	<input type="checkbox"/>
Are the sensors mounted correctly (distance, 1 traverse, 2 traverses) → 23?	<input type="checkbox"/>
Are the measuring point identification and labeling correct (visual inspection)?	<input type="checkbox"/>
Is the device adequately protected from precipitation and direct sunlight?	<input type="checkbox"/>

Are the securing screw and securing clamp tightened securely?	<input type="checkbox"/>
Is potential equalization established at the sensor holder (in the event of different potentials between the sensor holder and transmitter) ?	<input type="checkbox"/>

7 Electrical connection

NOTICE

The measuring device does not have an internal circuit breaker.

- ▶ For this reason, assign the measuring device a switch or power-circuit breaker so that the power supply line can be easily disconnected from the mains.
- ▶ Although the measuring device is equipped with a fuse, additional overcurrent protection (maximum 16 A) should be integrated into the system installation.

7.1 Electrical safety

In accordance with applicable national regulations.

7.2 Connection conditions

7.2.1 Required tools

- Torque wrench
- For cable entries: Use corresponding tools
- Wire stripper
- When using stranded cables: Crimper for wire end ferrule

7.2.2 Requirements for connecting cable

The connecting cables provided by the customer must fulfill the following requirements.

Permitted temperature range

- The installation guidelines that apply in the country of installation must be observed.
- The cables must be suitable for the minimum and maximum temperatures to be expected.

Power supply cable (incl. conductor for the inner ground terminal)

Standard installation cable is sufficient.

Signal cable

Current output 0/4 to 20 mA

Standard installation cable is sufficient.

Current output 4 to 20 mA HART

A shielded cable is recommended. Observe grounding concept of the plant.

Pulse/frequency/switch output

Standard installation cable is sufficient.

Status input

Standard installation cable is sufficient.

Sensor cable for sensor - transmitter

Standard cable	<ul style="list-style-type: none"> ■ TPE: -40 to +80 °C (-40 to +176 °F) ■ TPE halogen-free: -40 to +80 °C (-40 to +176 °F) ■ PTFE: -40 to +130 °C (-40 to +266 °F)
Cable length (max.)	30 m (90 ft)
Cable lengths (available for order)	5 m (15 ft), 10 m (30 ft), 15 m (45 ft), 30 m (90 ft)
Operating temperature	Depends on the device version and how the cable is installed: Standard version: <ul style="list-style-type: none"> ■ Cable, fixed installation ¹⁾: minimum -40 °C (-40 °F) ■ Cable, movable: minimum -25 °C (-13 °F)

1) Compare details under the "Standard cable" row

Cable diameter

- Cable glands supplied:
 - For standard cable: M20 × 1.5 with cable ϕ 6 to 12 mm (0.24 to 0.47 in)
 - For reinforced cable: M20 × 1.5 with cable ϕ 9.5 to 16 mm (0.37 to 0.63 in)
- (Plug-in) spring terminals for wire cross-sections 0.5 to 2.5 mm² (20 to 14 AWG)

7.2.3 Terminal assignment

Transmitter

The sensor can be ordered with terminals.

Connection methods available		Possible options for order code "Electrical connection"
Outputs	Power supply	
Terminals	Terminals	<ul style="list-style-type: none"> ■ Option A: coupling M20x1.5 ■ Option B: thread M20x1.5 ■ Option C: thread G ½" ■ Option D: thread NPT ½"

Supply voltage

Order code "Power supply"	Terminal numbers	terminal voltage		Frequency range
Option L (wide range power unit)	1 (L+/L), 2 (L-/N)	DC 24 V	±25%	-
		AC 24 V	±25%	50/60 Hz, ±4 Hz
		AC 100 to 240 V	-15 to +10%	50/60 Hz, ±4 Hz

Signal transmission for current output 0 to 20 mA/4 to 20 mA HART and other outputs and inputs

Order code for "Output" and "Input"	Terminal numbers							
	Output 1		Output 2		Output 3		Input	
	26 (+)	27 (-)	24 (+)	25 (-)	22 (+)	23 (-)	20 (+)	21 (-)
Option H	Current output <ul style="list-style-type: none"> ▪ 4 to 20 mA HART (active) ▪ 0 to 20 mA (active) 		Pulse/frequency output (passive)		Switch output (passive)		-	
Option I	Current output <ul style="list-style-type: none"> ▪ 4 to 20 mA HART (active) ▪ 0 to 20 mA (active) 		Pulse/frequency/switch output (passive)		Pulse/frequency/switch output (passive)		Status input	

7.2.4 Preparing the measuring device

Carry out the steps in the following order:

1. Mount the sensor and transmitter.
2. Sensor connection housing: Connect sensor cable.
3. Transmitter: Connect sensor cable.
4. Transmitter: Connect signal cable and cable for supply voltage.

NOTICE

Insufficient sealing of the housing!

Operational reliability of the measuring device could be compromised.

- ▶ Use suitable cable glands corresponding to the degree of protection.

1. Remove dummy plug if present.
2. If the measuring device is supplied without cable glands:
Provide suitable cable gland for corresponding connecting cable.
3. If the measuring device is supplied with cable glands:
Observe requirements for connecting cables → 44.

7.3 Connecting the measuring device

WARNING

Risk of electric shock! Components carry dangerous voltages!

- ▶ Have electrical connection work carried out by correspondingly trained specialists only.
- ▶ Observe applicable federal/national installation codes and regulations.
- ▶ Comply with local workplace safety regulations.
- ▶ Observe grounding concept of the plant.
- ▶ Never mount or wire the measuring device while it is connected to the supply voltage.
- ▶ Before the supply voltage is applied, connect the protective ground to the measuring device.

7.3.1 Connecting the sensor and transmitter

WARNING

Risk of damaging electronic components!

- ▶ Connect the sensor and transmitter to the same potential equalization.
- ▶ Only connect the sensor to a transmitter with the same serial number.

The following sequence of steps is recommended when connecting:

1. Mount the sensor and transmitter.
2. Connect the sensor cable.
3. Connect the transmitter.

Connecting the sensor cable to the transmitter

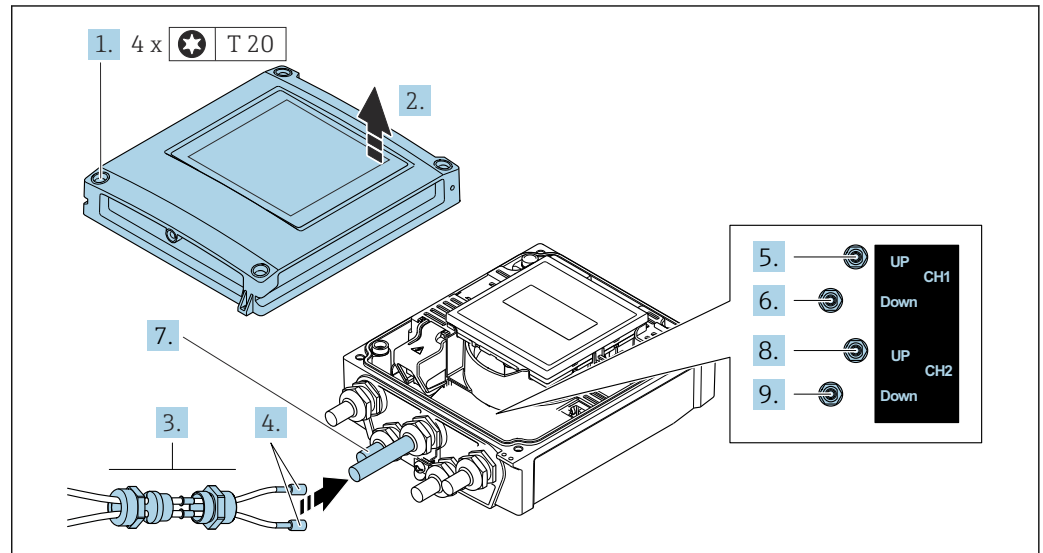

37 Transmitter: main electronics module with terminals

1. Loosen the 4 fixing screws on the housing cover.
2. Open the housing cover.
3. Route the two sensor cables of channel 1 through the slackened top union nut of the cable entry. To ensure tight sealing, mount a sealing insert on the sensor cables (push the cables through the slotted sealing insert).
4. Mount the screw part in the center cable entry at the top and then guide both sensor cables through the entry. Then fit the coupling nut with the sealing insert on the screw part and tighten. Ensure that the sensor cables are positioned in the cut-outs provided in the screw part.
5. Connect sensor cable to channel 1 upstream.
6. Connect sensor cable to channel 1 downstream.
7. For a two-path measurement: proceed as per steps 3+4
8. Connect sensor cable to channel 2 upstream.
9. Connect sensor cable to channel 2 downstream.
10. Tighten the cable gland(s).
 - ↳ This concludes the process for connecting the sensor cable(s).
11. **⚠ WARNING**
Housing degree of protection may be voided due to insufficient sealing of the housing.
 - ▶ Screw in the screw without using any lubricant.

Reverse the removal procedure to reassemble the transmitter.

7.3.2 Connecting the transmitter

⚠ WARNING

Housing degree of protection may be voided due to insufficient sealing of the housing.

- ▶ Screw in the screw without using any lubricant. The threads on the cover are coated with a dry lubricant.

Tightening torques for plastic housing

Housing cover fixing screw	1 Nm (0.7 lbf ft)
Cable entry	5 Nm (3.7 lbf ft)
Ground terminal	2.5 Nm (1.8 lbf ft)

- i** When connecting the cable shield to the ground terminal, observe the grounding concept of the facility.

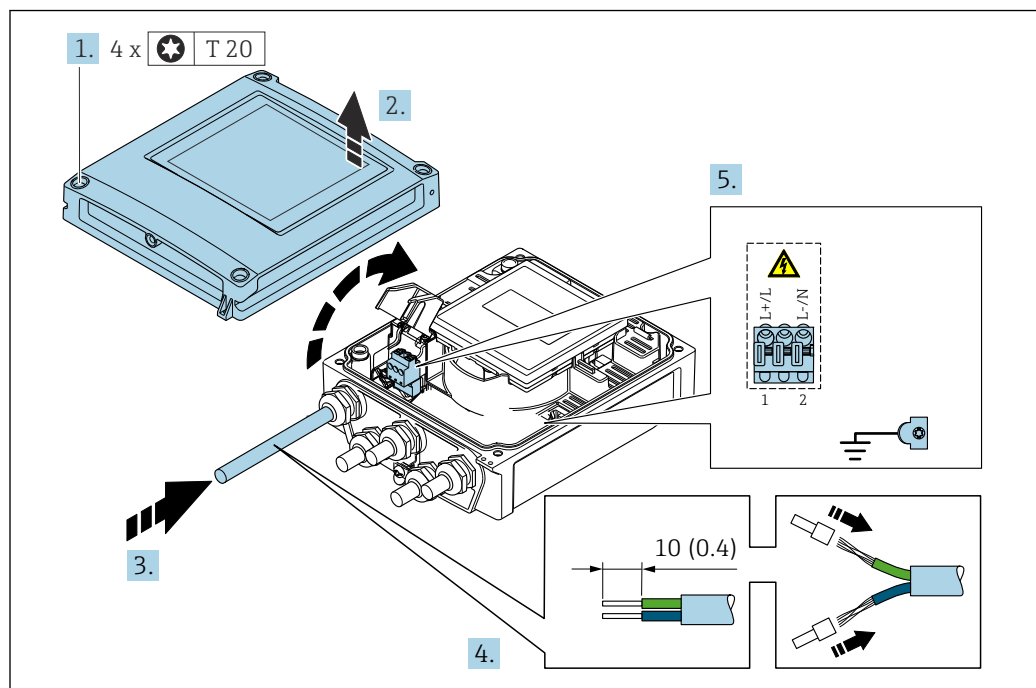

38 Connecting the supply voltage and 0-20 mA/4-20 mA HART with additional outputs and inputs

1. Loosen the 4 fixing screws on the housing cover.
2. Open the housing cover.
3. Push the cable through the cable entry. To ensure tight sealing, do not remove the sealing ring from the cable entry.
4. Strip the cable and cable ends. In the case of stranded cables, also fit ferrules.
5. Connect the cable according to the terminal assignment → **45**. For supply voltage: open the shock protection cover.
6. Firmly tighten the cable glands.

Reassembling the transmitter

1. Close the shock protection cover.
2. Close the housing cover.

3. **⚠ WARNING**

Housing degree of protection may be voided due to insufficient sealing of the housing.

- Screw in the screw without using any lubricant.

Tighten the 4 fixing screws on the housing cover.

7.3.3 Potential equalization

Requirements

For potential equalization:

- Pay attention to in-house grounding concepts
- Take account of operating conditions like the pipe material and grounding
- Connect the sensor and transmitter to the same electrical potential
- Use a ground cable with a minimum cross-section of 6 mm² (0.0093 in²) for the potential equalization connections

7.4 Special connection instructions

7.4.1 Connection examples

Current output 4 to 20 mA HART

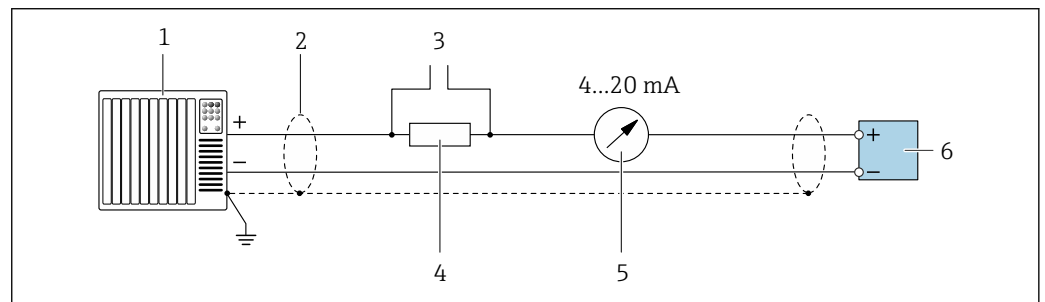

39 Connection example for 4 to 20 mA HART current output (active)

- 1 Automation system with current input (e.g. PLC)
- 2 Ground the cable shield at one end. The cable shield must be grounded at both ends to comply with EMC requirements; observe cable specifications
- 3 Connection for HART operating devices → 72
- 4 Resistor for HART communication ($\geq 250 \Omega$): observe maximum load → 151
- 5 Analog display unit: observe maximum load → 151
- 6 Transmitter

Pulse/frequency output

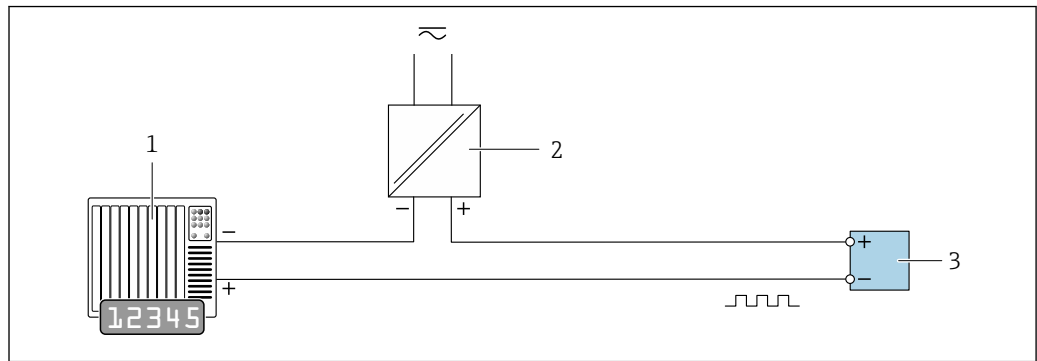

A0028761

40 Connection example for pulse/frequency output (passive)

- 1 Automation system with pulse/frequency input (e.g. PLC)
- 2 Power supply
- 3 Transmitter: Observe input values → 151

Switch output

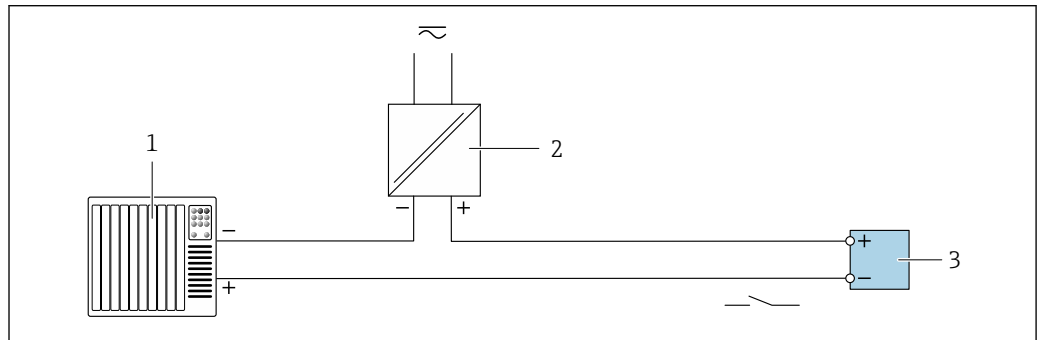

A0028760

41 Connection example for switch output (passive)

- 1 Automation system with switch input (e.g. PLC)
- 2 Power supply
- 3 Transmitter: Observe input values → 151

Status input

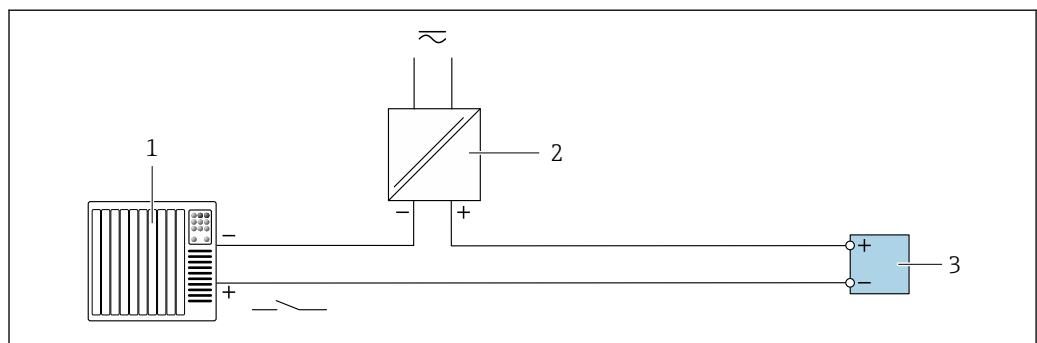

A0028764

42 Connection example for status input

- 1 Automation system with status output (e.g. PLC)
- 2 Power supply
- 3 Transmitter

7.5 Ensuring the degree of protection

7.5.1 Degree of protection IP66/67, Type 4X enclosure

The measuring device fulfills all the requirements for the IP66/67 degree of protection, Type 4X enclosure.

To guarantee IP66/67 degree of protection, Type 4X enclosure, carry out the following steps after the electrical connection:

1. Check that the housing seals are clean and fitted correctly. Dry, clean or replace the seals if necessary.
2. Tighten all housing screws and screw covers.
3. Firmly tighten the cable glands.
4. To ensure that moisture does not enter the cable entry, route the cable so that it loops down before the cable entry ("water trap").

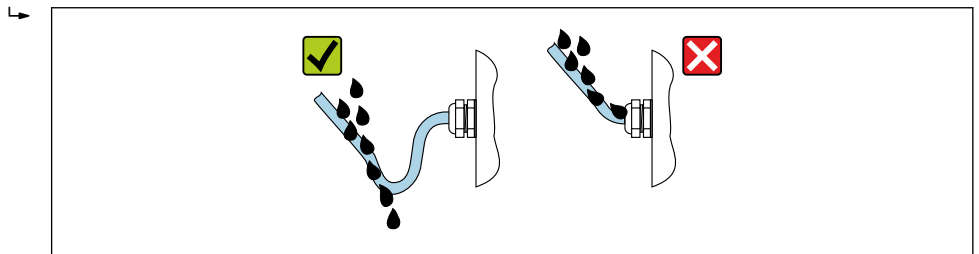

A0029278

5. Insert dummy plugs (corresponding to the housing degree of protection) into unused cable entries.

NOTICE

Standard dummy plugs used for transportation do not have the appropriate degree of protection and can result in damage to the device!

- ▶ Use suitable dummy plugs corresponding to the degree of protection.

7.6 Post-connection check

Are cables or the device undamaged (visual inspection)?	<input type="checkbox"/>
Do the cables comply with the requirements → 44?	<input type="checkbox"/>
Do the cables have adequate strain relief?	<input type="checkbox"/>
Are all cable glands installed, securely tightened and leak-tight? Cable run with "water trap" → 51?	<input type="checkbox"/>
Does the supply voltage match the specifications on the transmitter nameplate → 154?	<input type="checkbox"/>
Is the terminal assignment correct → 45?	<input type="checkbox"/>
If supply voltage is present, do values appear on the display module?	<input type="checkbox"/>
Are all housing covers installed and the screws tightened with the correct tightening torque?	<input type="checkbox"/>

8 Operation options

8.1 Overview of operation methods

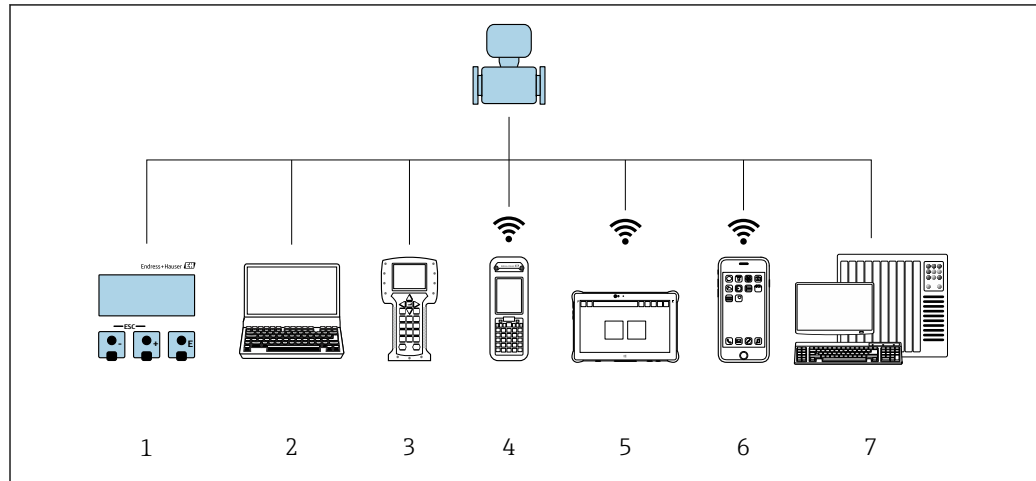



A0046477

- 1 Local operation via display module
- 2 Computer with Web browser (e.g. Internet Explorer) or with operating tool (e.g. FieldCare, DeviceCare, AMS Device Manager, SIMATIC PDM)
- 3 Field Communicator 475
- 4 Field Xpert SFX350 or SFX370
- 5 Field Xpert SMT70
- 6 Mobile handheld terminal
- 7 Control system (e.g. PLC)

8.2 Structure and function of the operating menu

8.2.1 Structure of the operating menu

 For an overview of the operating menu for experts: see the "Description of Device Parameters" document supplied with the device →  167



 43 Schematic structure of the operating menu

A0018237-EN

8.2.2 Operating philosophy

The individual parts of the operating menu are assigned to certain user roles (operator, maintenance etc.). Each user role contains typical tasks within the device lifecycle.

Menu/parameter		User role and tasks	Content/meaning
Language	task-oriented	Role "Operator", "Maintenance" Tasks during operation: <ul style="list-style-type: none"> ▪ Configuration of the operational display ▪ Reading off measured values 	<ul style="list-style-type: none"> ▪ Definition of the operating language ▪ Definition of the Web server operating language ▪ Resetting and controlling totalizers
Operation			<ul style="list-style-type: none"> ▪ Configuration of the operational display (e.g. display format, display contrast) ▪ Resetting and controlling totalizers
Setup		"Maintenance" role Commissioning: <ul style="list-style-type: none"> ▪ Configuration of the measurement ▪ Configuration of the outputs 	Wizards for fast commissioning: <ul style="list-style-type: none"> ▪ Configuration of the measuring point ▪ Configuration of the system units ▪ Configuration of the input ▪ Configuration of the outputs ▪ Configuration of the operational display ▪ Definition of output conditioning ▪ Setting the low flow cut off Advanced setup <ul style="list-style-type: none"> ▪ For more customized configuration of the measurement (adaptation to special measuring conditions) ▪ Configuration of the totalizers ▪ Configuration of WLAN settings ▪ Administration (define access code, reset measuring device)
Diagnostics		"Maintenance" role Troubleshooting: <ul style="list-style-type: none"> ▪ Diagnostics and elimination of process and device errors ▪ Measured value simulation 	Contains all parameters for error detection and analyzing process and device errors: <ul style="list-style-type: none"> ▪ Diagnostic list Contains up to 5 currently pending diagnostic messages. ▪ Event logbook Contains event messages that have occurred. ▪ Device information Contains information for identifying the device. ▪ Measured values Contains all current measured values. ▪ Data logging submenu with the "Extended HistoROM" order option Storage and visualization of measured values ▪ Heartbeat The functionality of the device is checked on demand and the verification results are documented. ▪ Simulation Is used to simulate measured values or output values.
Expert	function-oriented	Tasks that require detailed knowledge of the function of the device: <ul style="list-style-type: none"> ▪ Commissioning measurements under difficult conditions ▪ Optimal adaptation of the measurement to difficult conditions ▪ Detailed configuration of the communication interface ▪ Error diagnostics in difficult cases 	Contains all the parameters of the device and makes it possible to access these parameters directly using an access code. The structure of this menu is based on the function blocks of the device: <ul style="list-style-type: none"> ▪ System Contains all higher-order device parameters that do not pertain either to the measurement or measured value communication. ▪ Sensor Configuration of the measurement. ▪ Input Configuration of the status input. ▪ Output Configuration of the analog current outputs as well as the pulse/frequency and switch output. ▪ Communication Configuration of the digital communication interface and the Web server. ▪ Application Configuration of the functions that go beyond the actual measurement (e.g. totalizer). ▪ Diagnostics Error detection and analysis of process and device errors and for device simulation and Heartbeat Technology.

8.3 Access to the operating menu via the local display

8.3.1 Operational display

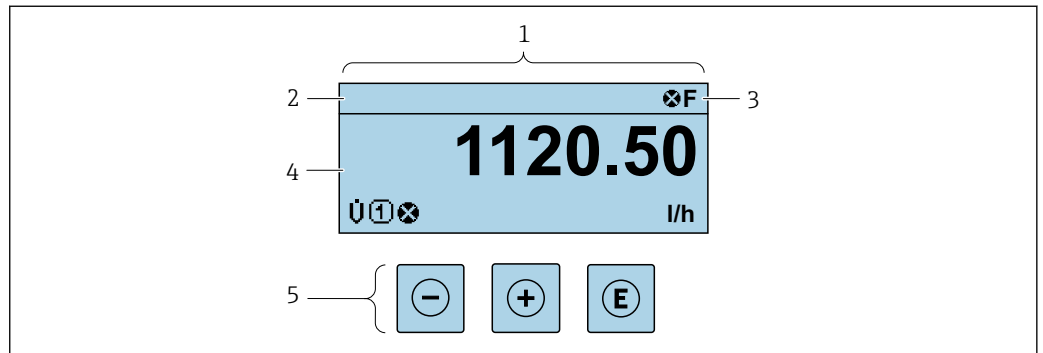

A0029346

- 1 Operational display
- 2 Device tag → 82
- 3 Status area
- 4 Display area for measured values (4-line)
- 5 Operating elements → 60

Status area

The following symbols appear in the status area of the operational display at the top right:

- Status signals → 128
 - **F**: Failure
 - **C**: Function check
 - **S**: Out of specification
 - **M**: Maintenance required
- Diagnostic behavior → 129
 - : Alarm
 - : Warning
- : Locking (the device is locked via the hardware)
- : Communication (communication via remote operation is active)

Display area

In the display area, each measured value is prefaced by certain symbol types for further description:

	Measured variable	Measurement channel number	Diagnostic behavior
	↓	↓	↓
Example			

Appears only if a diagnostics event is present for this measured variable.

Measured variables

Symbol	Meaning
	Volume flow
	Mass flow

C	Speed of sound
	Flow velocity
SNR	Signal to noise ratio
	Signal strength
	Totalizer The measurement channel number indicates which of the three totalizers is displayed.
	Output The measurement channel number indicates which of the outputs is displayed.
	Status input

Measurement channel numbers

Symbol	Meaning
	Measurement channel 1 to 4
The measurement channel number is displayed only if more than one channel is present for the same measured variable type (e.g. Totalizer 1 to 3).	

Diagnostic behavior

The diagnostic behavior pertains to a diagnostic event that is relevant to the displayed measured variable. For information on the symbols → 129



The number and display format of the measured values can be configured via the **Format display** parameter (→ 98).



8.3.2 Navigation view

In the submenu	In the wizard
A0013993-EN	A0016327-EN
<p>1 Navigation view 2 Navigation path to current position 3 Status area 4 Display area for navigation 5 Operating elements → 60</p>	

Navigation path

The navigation path - displayed at the top left in the navigation view - consists of the following elements:



	<ul style="list-style-type: none"> In the submenu: Display symbol for menu In the wizard: Display symbol for wizard 	Omission symbol for operating menu levels in between	Name of current <ul style="list-style-type: none"> Submenu Wizard Parameters
Examples	↓	↓	↓
		/ .. /	Display
		/ .. /	Display

 For more information about the icons in the menu, refer to the "Display area" section →  57

Status area





The following appears in the status area of the navigation view in the top right corner:

- In the submenu
 - The direct access code for the parameter you are navigating to (e.g. 0022-1)
 - If a diagnostic event is present, the diagnostic behavior and status signal
- In the wizard
 - If a diagnostic event is present, the diagnostic behavior and status signal





-  For information on the diagnostic behavior and status signal →  128
- For information on the function and entry of the direct access code →  62

Display area

Menus

Symbol	Meaning
	Operation Appears: <ul style="list-style-type: none"> In the menu next to the "Operation" selection At the left in the navigation path in the Operation menu
	Setup Appears: <ul style="list-style-type: none"> In the menu next to the "Setup" selection At the left in the navigation path in the Setup menu
	Diagnostics Appears: <ul style="list-style-type: none"> In the menu next to the "Diagnostics" selection At the left in the navigation path in the Diagnostics menu
	Expert Appears: <ul style="list-style-type: none"> In the menu next to the "Expert" selection At the left in the navigation path in the Expert menu



Submenus, wizards, parameters

Symbol	Meaning
	Submenu
	Wizard
	Parameters within a wizard  No display symbol exists for parameters in submenus.

Locking

Symbol	Meaning
	Parameter locked When displayed in front of a parameter name, indicates that the parameter is locked. <ul style="list-style-type: none"> By a user-specific access code By the hardware write protection switch

Wizard operation

Symbol	Meaning
	Switches to the previous parameter.
	Confirms the parameter value and switches to the next parameter.
	Opens the editing view of the parameter.



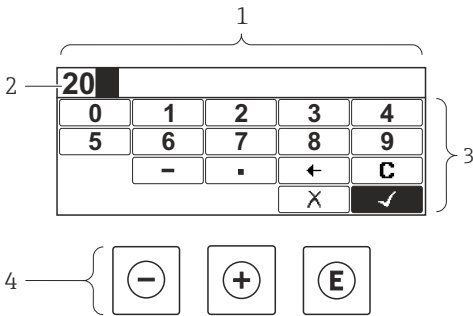
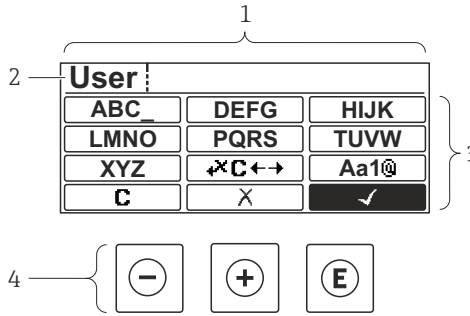

8.3.3 Editing view

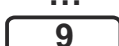

Numeric editor	Text editor
	
<p>1 Editing view</p> <p>2 Display area of the entered values</p> <p>3 Input mask</p> <p>4 Operating elements → 60</p>	<p>1 Editing view</p> <p>2 Display area of the entered values</p> <p>3 Input mask</p> <p>4 Operating elements → 60</p>

Input mask

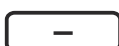









The following input symbols are available in the input mask of the numeric and text editor:

Numeric editor



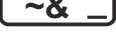

Symbol	Meaning
	Selection of numbers from 0 to 9.
	
	Inserts decimal separator at the input position.
	Inserts minus sign at the input position.
	Confirms selection.
	Moves the input position one position to the left.

	Exits the input without applying the changes.
	Clears all entered characters.





Text editor

Symbol	Meaning
	Toggle <ul style="list-style-type: none"> ▪ Between upper-case and lower-case letters ▪ For entering numbers ▪ For entering special characters
 ... 	Selection of letters from A to Z.
 ... 	Selection of letters from a to z.
 ... 	Selection of special characters.
	Confirms selection.
	Switches to the selection of the correction tools.
	Exits the input without applying the changes.
	Clears all entered characters.

Correction symbols under 

Symbol	Meaning
	Clears all entered characters.
	Moves the input position one position to the right.
	Moves the input position one position to the left.
	Deletes one character immediately to the left of the input position.

8.3.4 Operating elements

Key	Meaning
	<p>Minus key</p> <p><i>In menu, submenu</i> Moves the selection bar upwards in a picklist.</p> <p><i>With a wizard</i> Confirms the parameter value and goes to the previous parameter.</p> <p><i>For text and numeric editor</i> In the input mask, moves the selection bar to the left (backwards).</p>
	<p>Plus key</p> <p><i>In menu, submenu</i> Moves the selection bar downwards in a picklist.</p> <p><i>With a wizard</i> Confirms the parameter value and goes to the next parameter.</p> <p><i>For text and numeric editor</i> In the input mask, moves the selection bar to the right (forwards).</p>
	<p>Enter key</p> <p><i>For operational display</i> Pressing the key for 2 s opens the context menu including the selection for activating the keypad lock.</p> <p><i>In menu, submenu</i></p> <ul style="list-style-type: none"> ▪ Pressing the key briefly: <ul style="list-style-type: none"> ▪ Opens the selected menu, submenu or parameter. ▪ Starts the wizard. ▪ If help text is open, closes the help text of the parameter. ▪ Pressing the key for 2 s in a parameter: <ul style="list-style-type: none"> ▪ If present, opens the help text for the function of the parameter. <p><i>With a wizard</i> Opens the editing view of the parameter.</p> <p><i>For text and numeric editor</i></p> <ul style="list-style-type: none"> ▪ Pressing the key briefly: <ul style="list-style-type: none"> ▪ Opens the selected group. ▪ Carries out the selected action. ▪ Pressing the key for 2 s confirms the edited parameter value.
	<p>Escape key combination (press keys simultaneously)</p> <p><i>In menu, submenu</i></p> <ul style="list-style-type: none"> ▪ Pressing the key briefly: <ul style="list-style-type: none"> ▪ Exits the current menu level and takes you to the next level up. ▪ If help text is open, closes the help text of the parameter. ▪ Pressing the key for 2 s returns you to the operational display ("home position"). <p><i>With a wizard</i> Exits the wizard and takes you to the next level up.</p> <p><i>For text and numeric editor</i> Closes the text or numeric editor without applying changes.</p>
	<p>Minus/Plus/Enter key combination (press and hold down the keys simultaneously)</p> <p><i>For operational display</i> Enables or disables the keypad lock (only SD02 display module).</p>



8.3.5 Opening the context menu

Using the context menu, the user can call up the following menus quickly and directly from the operational display:

- Setup
- Simulation



Calling up and closing the context menu

The user is in the operational display.

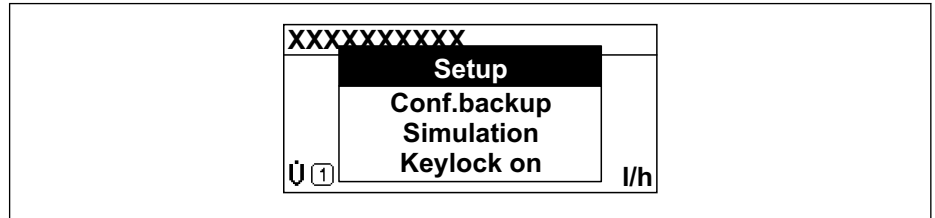

1. Press the  and  keys for longer than 3 seconds.
↳ The context menu opens.



A0034608-EN

2. Press  +  simultaneously.
↳ The context menu is closed and the operational display appears.

Calling up the menu via the context menu

1. Open the context menu.
2. Press  to navigate to the desired menu.
3. Press  to confirm the selection.
↳ The selected menu opens.

8.3.6 Navigating and selecting from list

Different operating elements are used to navigate through the operating menu. The navigation path is displayed on the left in the header. Icons are displayed in front of the individual menus. These icons are also shown in the header during navigation.

i For an explanation of the navigation view with symbols and operating elements → 56

Example: Setting the number of displayed measured values to "2 values"

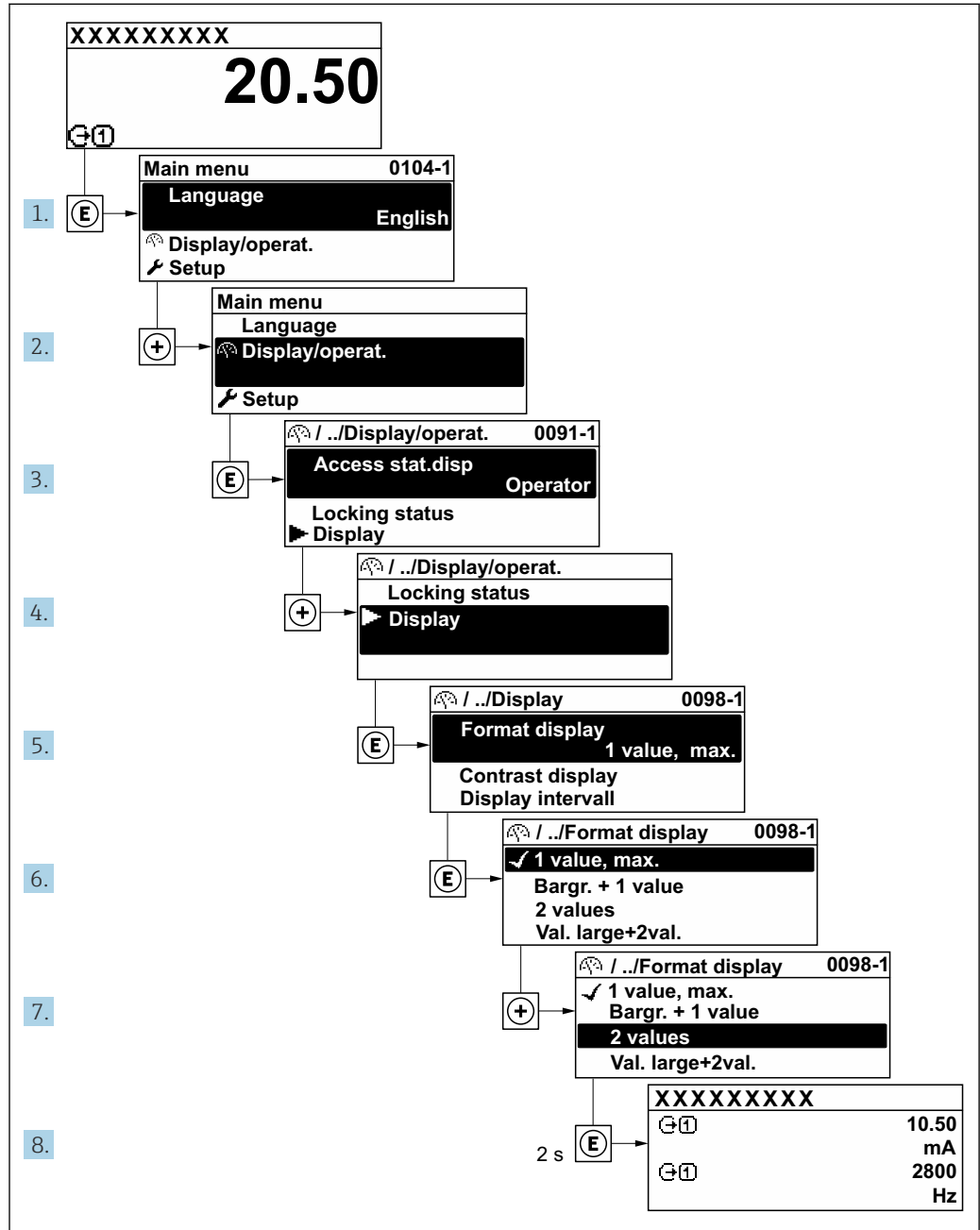

A0029562-EN

8.3.7 Calling the parameter directly

A parameter number is assigned to every parameter to be able to access a parameter directly via the onsite display. Entering this access code in the **Direct access** parameter calls up the desired parameter directly.

Navigation path

Expert → Direct access

The direct access code consists of a 5-digit number (at maximum) and the channel number, which identifies the channel of a process variable: e.g. 00914-2. In the navigation view, this appears on the right-hand side in the header of the selected parameter.

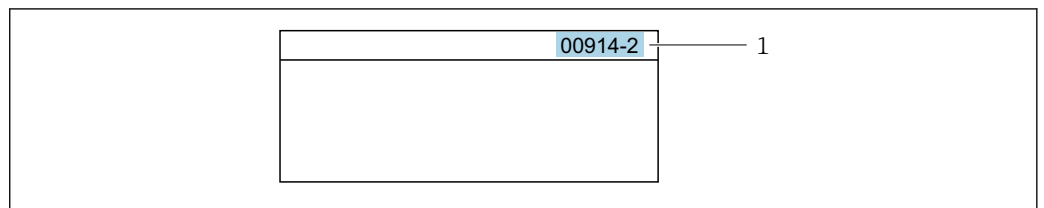

A0029414

1 Direct access code

Note the following when entering the direct access code:

- The leading zeros in the direct access code do not have to be entered.
Example: Enter "914" instead of "00914"
- If no channel number is entered, channel 1 is opened automatically.
Example: Enter 00914 → **Assign process variable** parameter
- If a different channel is opened: Enter the direct access code with the corresponding channel number.
Example: Enter 00914-2 → **Assign process variable** parameter



For the direct access codes of the individual parameters, see the "Description of Device Parameters" document for the device

8.3.8 Calling up help text

Help text is available for some parameters and can be called up from the navigation view. The help text provides a brief explanation of the parameter function and thereby supports swift and safe commissioning.

Calling up and closing the help text

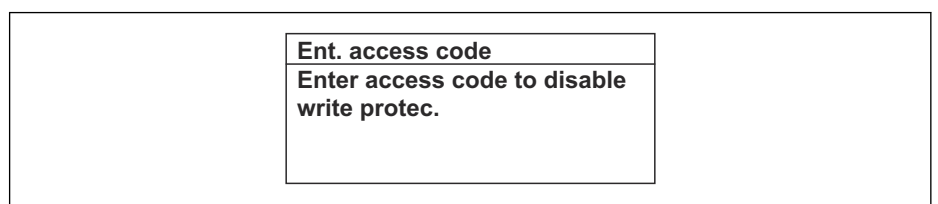

The user is in the navigation view and the selection bar is on a parameter.

1. Press  for 2 s.
↳ The help text for the selected parameter opens.



A0014002-EN

 44 Example: Help text for parameter "Enter access code"

2. Press  +  simultaneously.
↳ The help text is closed.

8.3.9 Changing the parameters

i For a description of the editing view - consisting of the text editor and numeric editor - with symbols → 58, for a description of the operating elements → 60

Example: Changing the tag name in the "Tag description" parameter from 001-FT-101 to 001-FT-102

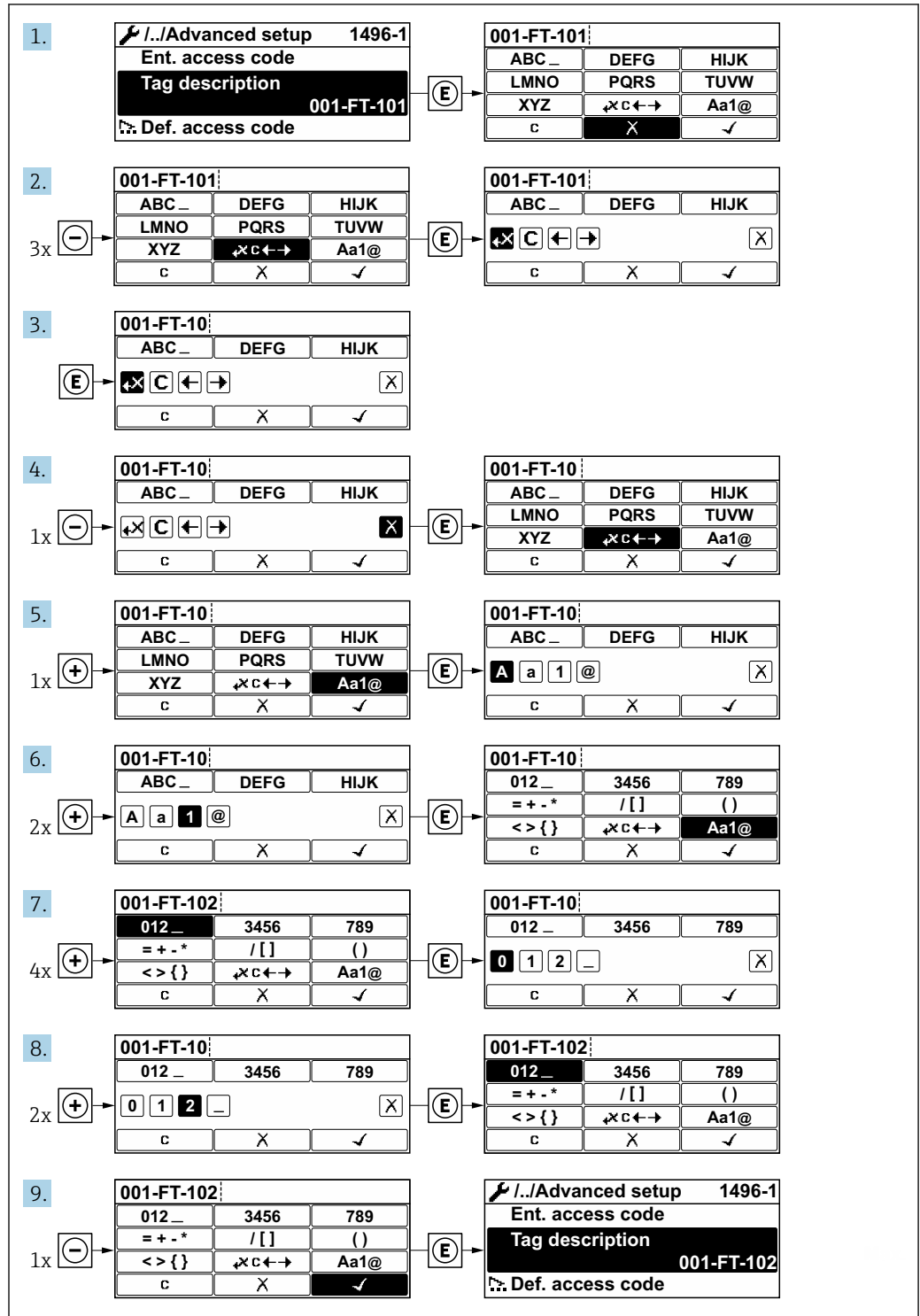

A0029563-EN

A message is displayed if the value entered is outside the permitted value range.

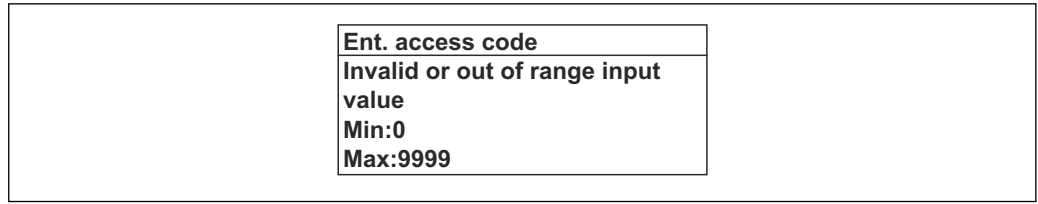

A0014049-EN

8.3.10 User roles and related access authorization

The two user roles "Operator" and "Maintenance" have different write access to the parameters if the customer defines a user-specific access code. This protects the device configuration via the local display from unauthorized access → 113.

Defining access authorization for user roles

An access code is not yet defined when the device is delivered from the factory. Access authorization (read and write access) to the device is not restricted and corresponds to the "Maintenance" user role.

- ▶ Define the access code.
 - ↳ The "Operator" user role is redefined in addition to the "Maintenance" user role. Access authorization differs for the two user roles.

Access authorization to parameters: "Maintenance" user role

Access code status	Read access	Write access
An access code has not yet been defined (factory setting).	✓	✓
After an access code has been defined.	✓	✓ ¹⁾

1) The user only has write access after entering the access code.

Access authorization to parameters: "Operator" user role

Access code status	Read access	Write access
After an access code has been defined.	✓	-- ¹⁾

1) Despite the defined access code, certain parameters can always be modified and thus are excepted from the write protection, as they do not affect the measurement. Refer to the "Write protection via access code" section

The user role with which the user is currently logged on is indicated by the **Access status display** parameter. Navigation path: Operation → Access status display

8.3.11 Disabling write protection via access code

If the -symbol appears on the local display in front of a parameter, the parameter is write-protected by a user-specific access code and its value cannot be changed at the moment using local operation → 113.

Parameter write protection via local operation can be disabled by entering the user-specific access code in the **Enter access code** parameter (→ 102) via the respective access option.

1. After you press , the input prompt for the access code appears.
2. Enter the access code.
 - ↳ The -symbol in front of the parameters disappears; all previously write-protected parameters are now re-enabled.

8.3.12 Enabling and disabling the keypad lock



The keypad lock makes it possible to block access to the entire operating menu via local operation. As a result, it is no longer possible to navigate through the operating menu or change the values of individual parameters. Users can only read the measured values on the operational display.

The keypad lock is switched on and off via the context menu.

Switching on the keypad lock



-  The keypad lock is switched on automatically:
- If the device has not been operated via the display for > 1 minute.
 - Each time the device is restarted.

To activate the keylock manually:

1. The device is in the measured value display.
Press the  and  keys for 3 seconds.
↳ A context menu appears.
2. In the context menu select the **Keylock on** option.
↳ The keypad lock is switched on.

-  If the user attempts to access the operating menu while the keypad lock is active, the **Keylock on** message appears.

Switching off the keypad lock



- ▶ The keypad lock is switched on.
Press the  and  keys for 3 seconds.
↳ The keypad lock is switched off.

8.4 Access to the operating menu via the Web browser

8.4.1 Function scope

Thanks to the integrated Web server the device can be operated and configured via a Web browser and via a standard Ethernet switch (RJ45) or via a WLAN interface. The structure of the operating menu is the same as the menu on the local display. In addition to the measured values, status information about the device is also displayed and allows the user to monitor the status of the device. Furthermore the device data can be managed and the network parameters can be configured.

A device that has a WLAN interface (can be ordered as an option) is required for the WLAN connection: order code for "Display", option G "4-line, illuminated; Touch Control +WLAN". The device acts as an Access Point and enables communication by computer or a mobile handheld terminal.

-  For additional information on the Web server, refer to the Special Documentation for the device →  167

8.4.2 Requirements



Computer hardware

Interface	The computer must have an RJ45 interface.
Connection	Standard Ethernet cable with RJ45 connector.
Screen	Recommended size: ≥12" (depends on the screen resolution)

Computer software



Recommended operating systems	Microsoft Windows 7 or higher.  Microsoft Windows XP is supported.
Web browsers supported	<ul style="list-style-type: none"> ▪ Microsoft Internet Explorer 8 or higher ▪ Microsoft Edge ▪ Mozilla Firefox ▪ Google Chrome ▪ Safari

Computer settings



User rights	Appropriate user rights (e.g. administrator rights) for TCP/IP and proxy server settings are necessary (for adjusting the IP address, subnet mask etc.).
Proxy server settings of the Web browser	The Web browser setting <i>Use proxy server for LAN</i> must be disabled .
JavaScript	<p>JavaScript must be enabled.</p> <p> If JavaScript cannot be enabled: enter <code>http://192.168.1.212/basic.html</code> in the address line of the Web browser. A fully functional but simplified version of the operating menu structure starts in the Web browser.</p> <p> When installing a new firmware version: To enable correct data display, clear the temporary memory (cache) of the Web browser under Internet options.</p>
Network connections	<p>Only the active network connections to the measuring device should be used.</p> <p>Switch off all other network connections such as WLAN.</p>

 In the event of connection problems: →  126

Measuring device: Via CDI-RJ45 service interface

Device	CDI-RJ45 service interface
Measuring device	The measuring device has an RJ45 interface.
Web server	<p>Web server must be enabled; factory setting: ON</p> <p> For information on enabling the Web server →  71</p>

Measuring device: via WLAN interface

Device	WLAN interface
Measuring device	The measuring device has a WLAN antenna: Transmitter with integrated WLAN antenna
Web server	<p>Web server and WLAN must be enabled; factory setting: ON</p> <p> For information on enabling the Web server →  71</p>

8.4.3 Establishing a connection

Via service interface (CDI-RJ45)

Preparing the measuring device

Configuring the Internet protocol of the computer

The following information refers to the default Ethernet settings of the device.

IP address of the device: 192.168.1.212 (factory setting)

1. Switch on the measuring device.
2. Connect to the computer using a cable .
3. If a 2nd network card is not used, close all the applications on the notebook.
 - ↳ Applications requiring Internet or a network, such as e-mail, SAP applications, Internet or Windows Explorer.
4. Close any open Internet browsers.
5. Configure the properties of the Internet protocol (TCP/IP) as defined in the table:

IP address	192.168.1.XXX; for XXX all numerical sequences except: 0, 212 and 255 → e.g. 192.168.1.213
Subnet mask	255.255.255.0
Default gateway	192.168.1.212 or leave cells empty

Via WLAN interface

Configuring the Internet protocol of the mobile terminal

NOTICE

If the WLAN connection is lost during the configuration, settings made may be lost.

- ▶ Make sure that the WLAN connection is not disconnected while configuring the device.

NOTICE

In principle, avoid simultaneous access to the measuring device via the service interface (CDI-RJ45) and the WLAN interface from the same mobile terminal. This could cause a network conflict.

- ▶ Only activate one service interface (CDI-RJ45 service interface or WLAN interface).
- ▶ If simultaneous communication is necessary: configure different IP address ranges, e.g. 192.168.0.1 (WLAN interface) and 192.168.1.212 (CDI-RJ45 service interface).

Preparing the mobile terminal

- ▶ Enable WLAN reception on the mobile terminal.

Establishing a connection from the mobile terminal to the measuring device

1. In the WLAN settings of the mobile terminal:
Select the measuring device using the SSID (e.g. EH_Prosonic Flow_400_A802000).
2. If necessary, select the WPA2 encryption method.
3. Enter the password: serial number of the measuring device ex-works (e.g. L100A802000).
 - ↳ LED on display module flashes: it is now possible to operate the measuring device with the Web browser, FieldCare or DeviceCare.

 The serial number can be found on the nameplate.

 To ensure the safe and swift assignment of the WLAN network to the measuring point, it is advisable to change the SSID name. It should be possible to clearly assign the SSID name to the measuring point (e.g. tag name) as it is displayed as the WLAN network.

Disconnecting

- ▶ After configuring the device:
Terminate the WLAN connection between the operating unit and measuring device.

Starting the Web browser

1. Start the Web browser on the computer.
2. Enter the IP address of the Web server in the address line of the Web browser:
192.168.1.212
↳ The login page appears.

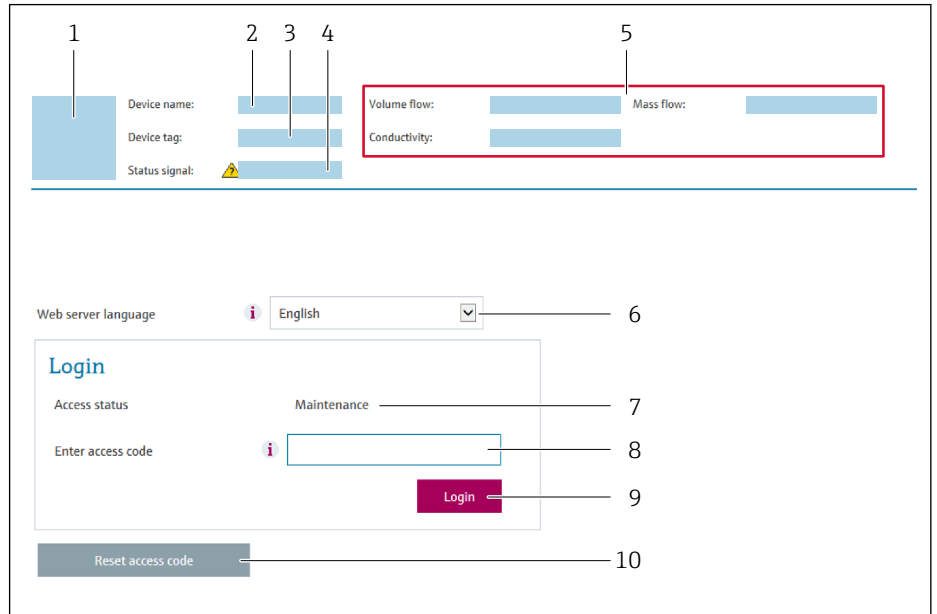

A0029417

- 1 Picture of device
- 2 Device name
- 3 Device tag (→ ⓘ 83)
- 4 Status signal
- 5 Current measured values
- 6 Operating language
- 7 User role
- 8 Access code
- 9 Login
- 10 Reset access code (→ ⓘ 110)

i If a login page does not appear, or if the page is incomplete → ⓘ 126

8.4.4 Logging on

1. Select the preferred operating language for the Web browser.
2. Enter the user-specific access code.
3. Press **OK** to confirm your entry.

Access code	0000 (factory setting); can be changed by customer
--------------------	--

i If no action is performed for 10 minutes, the Web browser automatically returns to the login page.

8.4.5 User interface

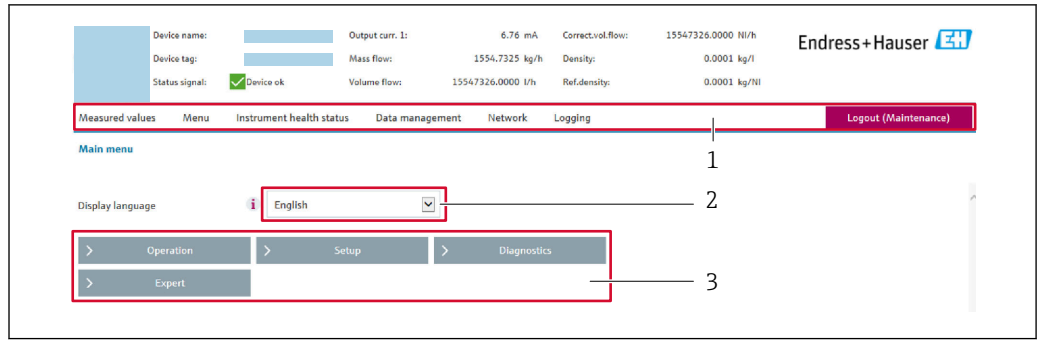

A0029418

- 1 Function row
- 2 Local display language
- 3 Navigation area

Header

The following information appears in the header:

- Device name
- Device tag
- Device status with status signal → 131
- Current measured values

Function row

Functions	Meaning
Measured values	Displays the measured values of the device
Menu	<ul style="list-style-type: none"> ■ Access to the operating menu from the measuring device ■ The structure of the operating menu is the same as for the local display For detailed information on the structure of the operating menu, see the Operating Instructions for the measuring device
Device status	Displays the diagnostic messages currently pending, listed in order of priority
Data management	Data exchange between PC and measuring device: <ul style="list-style-type: none"> ■ Device configuration: <ul style="list-style-type: none"> ■ Load settings from the device (XML format, save configuration) ■ Save settings to the device (XML format, restore configuration) ■ Logbook - Export Event logbook (.csv file) ■ Documents - Export documents: <ul style="list-style-type: none"> ■ Export backup data record (.csv file, create documentation of the measuring point configuration) ■ Verification report (PDF file, only available with the "Heartbeat Verification" application package)
Network configuration	Configuration and checking of all the parameters required for establishing the connection to the measuring device: <ul style="list-style-type: none"> ■ Network settings (e.g. IP address, MAC address) ■ Device information (e.g. serial number, firmware version)
Logout	End the operation and call up the login page

Navigation area

If a function is selected in the function bar, the submenus of the function open in the navigation area. The user can now navigate through the menu structure.

Working area

Depending on the selected function and the related submenus, various actions can be performed in this area:

- Configuring parameters
- Reading measured values
- Calling up help text
- Starting an upload/download

8.4.6 Disabling the Web server

The Web server of the measuring device can be switched on and off as required using the **Web server functionality** parameter.

Navigation

"Expert" menu → Communication → Web server

Parameter overview with brief description

Parameter	Description	Selection
Web server functionality	Switch the Web server on and off.	<ul style="list-style-type: none"> ▪ Off ▪ On

Function scope of the "Web server functionality" parameter

Option	Description
Off	<ul style="list-style-type: none"> ▪ The web server is completely disabled. ▪ Port 80 is locked.
On	<ul style="list-style-type: none"> ▪ The complete functionality of the web server is available. ▪ JavaScript is used. ▪ The password is transferred in an encrypted state. ▪ Any change to the password is also transferred in an encrypted state.

Enabling the Web server

If the Web server is disabled it can only be re-enabled with the **Web server functionality** parameter via the following operating options:

- Via local display
- Via Bedientool "FieldCare"
- Via "DeviceCare" operating tool

8.4.7 Logging out

 Before logging out, perform a data backup via the **Data management** function (upload configuration from device) if necessary.

1. Select the **Logout** entry in the function row.
↳ The home page with the Login box appears.
2. Close the Web browser.
3. If no longer needed:
Reset modified properties of the Internet protocol (TCP/IP) →  67.

8.5 Access to the operating menu via the operating tool

The structure of the operating menu in the operating tools is identical to operation via the local display.

8.5.1 Connecting the operating tool

Via HART protocol

This communication interface is available in device versions with a HART output.

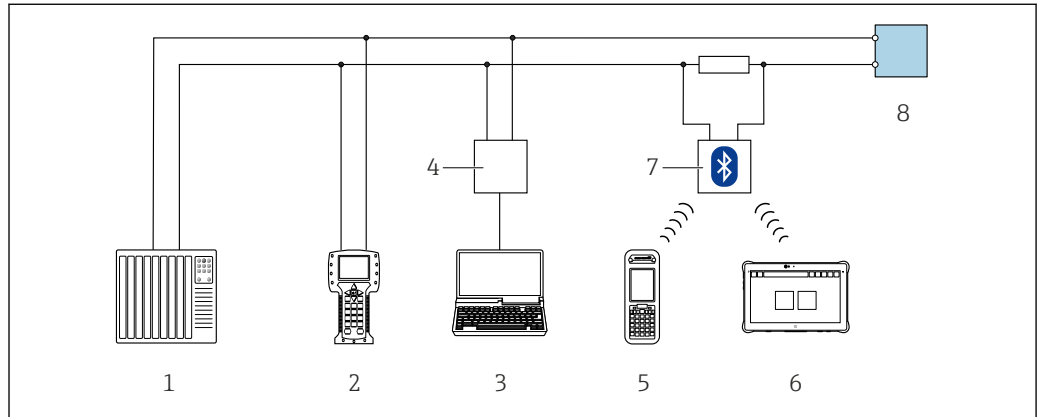

A0028747

45 Options for remote operation via HART protocol

- 1 Control system (e.g. PLC)
- 2 Field Communicator 475
- 3 Computer with operating tool (e.g. FieldCare, AMS Device Manager, SIMATIC PDM)
- 4 Commubox FXA 195 (USB)
- 5 Field Xpert SFX350 or SFX370
- 6 Field Xpert SMT70
- 7 VIATOR Bluetooth modem with connecting cable
- 8 Transmitter

Via service interface (CDI-RJ45)

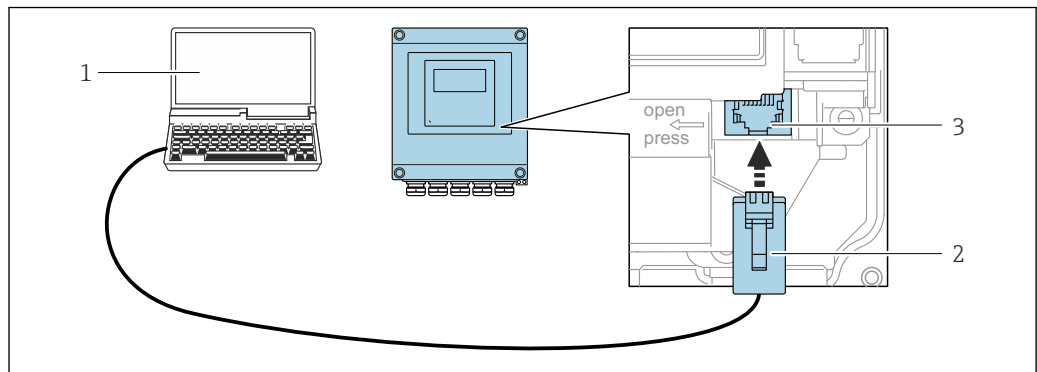

A0029163

46 Connection via service interface (CDI-RJ45)

- 1 Computer with Web browser (e.g. Microsoft Internet Explorer, Microsoft Edge) for accessing the integrated device Web server or with "FieldCare", "DeviceCare" operating tool with COM DTM "CDI Communication TCP/IP"
- 2 Standard Ethernet connecting cable with RJ45 plug
- 3 Service interface (CDI-RJ45) of the measuring device with access to the integrated Web server

Via WLAN interface

The optional WLAN interface is available on the following device version:

Order code for "Display; operation", option G "4-line, illuminated; touch control + WLAN"

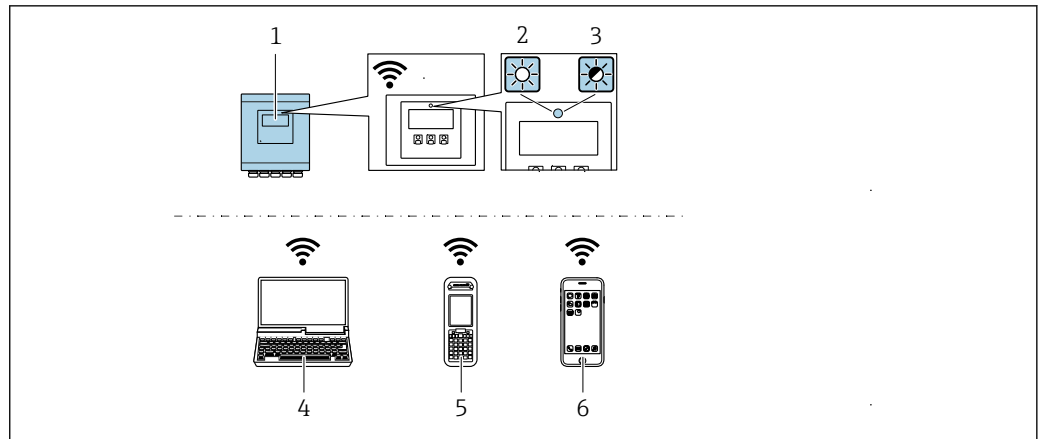

A0043149

- 1 Transmitter with integrated WLAN antenna
- 2 LED lit constantly: WLAN reception is enabled on measuring device
- 3 LED flashing: WLAN connection established between operating unit and measuring device
- 4 Computer with WLAN interface and Web browser (e.g. Microsoft Internet Explorer, Microsoft Edge) for accessing the integrated device Web server or with operating tool (e.g. FieldCare, DeviceCare)
- 5 Mobile handheld terminal with WLAN interface and Web browser (e.g. Microsoft Internet Explorer, Microsoft Edge) for accessing the integrated device Web server or operating tool (e.g. FieldCare, DeviceCare)
- 6 Smart phone or tablet (e.g. Field Xpert SMT70)

Function	WLAN: IEEE 802.11 b/g (2.4 GHz)
Encryption	WPA2-PSK AES-128 (in accordance with IEEE 802.11i)
Configurable WLAN channels	1 to 11
Degree of protection	IP67
Available antenna	Internal antenna
Range	Typically 10 m (32 ft)

Configuring the Internet protocol of the mobile terminal

NOTICE

If the WLAN connection is lost during the configuration, settings made may be lost.
 ▶ Make sure that the WLAN connection is not disconnected while configuring the device.

NOTICE

In principle, avoid simultaneous access to the measuring device via the service interface (CDI-RJ45) and the WLAN interface from the same mobile terminal. This could cause a network conflict.
 ▶ Only activate one service interface (CDI-RJ45 service interface or WLAN interface).
 ▶ If simultaneous communication is necessary: configure different IP address ranges, e.g. 192.168.0.1 (WLAN interface) and 192.168.1.212 (CDI-RJ45 service interface).

Preparing the mobile terminal

- ▶ Enable WLAN reception on the mobile terminal.

Establishing a connection from the mobile terminal to the measuring device

1. In the WLAN settings of the mobile terminal:
 Select the measuring device using the SSID (e.g. EH_Prosonic Flow_400_A802000).
2. If necessary, select the WPA2 encryption method.

3. Enter the password: serial number of the measuring device ex-works (e.g. L100A802000).
 - ↳ LED on display module flashes: it is now possible to operate the measuring device with the Web browser, FieldCare or DeviceCare.

 The serial number can be found on the nameplate.

 To ensure the safe and swift assignment of the WLAN network to the measuring point, it is advisable to change the SSID name. It should be possible to clearly assign the SSID name to the measuring point (e.g. tag name) as it is displayed as the WLAN network.

Disconnecting

- ▶ After configuring the device:
Terminate the WLAN connection between the operating unit and measuring device.

8.5.2 FieldCare

Function scope

FDT-based plant asset management tool from Endress+Hauser. It can configure all smart field devices in a system and helps you manage them. By using the status information, it is also a simple but effective way of checking their status and condition.

Access is via:

- HART protocol
- CDI-RJ45 service interface

Typical functions:

- Parameterization of transmitters
- Loading and saving device data (upload/download)
- Documentation of the measuring point
- Visualization of the measured value memory (line recorder) and event logbook

 For additional information about FieldCare, see Operating Instructions BA00027S and BA00059S

Source for device description files

See information →  77

Establishing a connection

1. Start FieldCare and launch the project.
2. In the network: Add a device.
 - ↳ The **Add device** window opens.
3. Select the **CDI Communication TCP/IP** option from the list and press **OK** to confirm.
4. Right-click **CDI Communication TCP/IP** and select the **Add device** option in the context menu that opens.
5. Select the desired device from the list and press **OK** to confirm.
 - ↳ The **CDI Communication TCP/IP (Configuration)** window opens.
6. Enter the device address in the **IP address** field: 192.168.1.212 and press **Enter** to confirm.
7. Establish the online connection to the device.

 For additional information, see Operating Instructions BA00027S and BA00059S

User interface

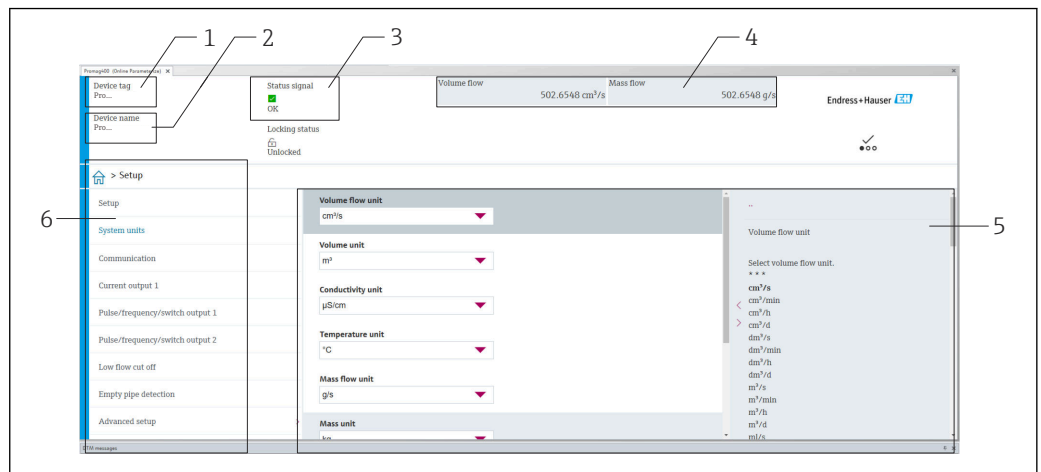

A0008200

- 1 Device name
- 2 Tag name
- 3 Status area with status signal → 131
- 4 Display area for current measured values
- 5 Edit bar with additional functions
- 6 Navigation area with operating menu structure

8.5.3 DeviceCare

Function scope

Tool for connecting and configuring Endress+Hauser field devices.

The fastest way to configure Endress+Hauser field devices is with the dedicated "DeviceCare" tool. Together with the device type managers (DTMs) it presents a convenient, comprehensive solution.



For details, see Innovation Brochure IN01047S

Source for device description files

See information → 77

8.5.4 Field Xpert SMT70, SMT77

Field Xpert SMT70

The Field Xpert SMT70 tablet PC for device configuration enables mobile plant asset management in hazardous and non-hazardous areas. It is suitable for commissioning and maintenance staff to manage field instruments with a digital communication interface and to record progress.

This tablet PC is designed as an all-in-one solution with a preinstalled driver library and is an easy-to-use, touch-sensitive tool which can be used to manage field instruments throughout their entire life cycle.



- Technical Information TI01342S
- Operating Instructions BA01709S
- Product page: www.endress.com/smt70



Source for device description files: → 77

Field Xpert SMT77

The Field Xpert SMT77 tablet PC for device configuration enables mobile plant asset management in areas categorized as Ex Zone 1.



- Technical Information TI01418S
- Operating Instructions BA01923S
- Product page: www.endress.com/smt77



Source for device description files: →  77

8.5.5 AMS Device Manager

Function scope

Program from Emerson Process Management for operating and configuring measuring devices via HART protocol.

Source for device description files

See data →  77

8.5.6 SIMATIC PDM

Function scope

SIMATIC PDM is a standardized, manufacturer-independent program from Siemens for the operation, configuration, maintenance and diagnosis of intelligent field devices via HART protocol.

Source for device description files

See information on →  77

9 System integration

9.1 Overview of device description files

9.1.1 Current version data for the device

Firmware version	01.00.zz	<ul style="list-style-type: none"> ▪ On the title page of the Operating Instructions ▪ On the transmitter nameplate ▪ Firmware version Diagnostics → Device information → Firmware version
Release date of firmware version	12.2021	---
Manufacturer ID	0x11	Manufacturer ID Diagnostics → Device information → Manufacturer ID
Device type ID	0x5D	Device type Diagnostics → Device information → Device type
HART protocol revision	7	---
Device revision	1	<ul style="list-style-type: none"> ▪ On the transmitter nameplate ▪ Device revision Diagnostics → Device information → Device revision

 For an overview of the various firmware versions for the device →  143

9.1.2 Operating tools

The suitable device description file for the individual operating tools is listed in the table below, along with information on where the file can be acquired.

Operating tool via HART protocol	Sources for obtaining device descriptions
FieldCare	<ul style="list-style-type: none"> ▪ www.endress.com → Download Area ▪ CD-ROM (contact Endress+Hauser) ▪ DVD (contact Endress+Hauser)
DeviceCare	<ul style="list-style-type: none"> ▪ www.endress.com → Download Area ▪ CD-ROM (contact Endress+Hauser) ▪ DVD (contact Endress+Hauser)
<ul style="list-style-type: none"> ▪ Field Xpert SMT70 ▪ Field Xpert SMT77 	Use update function of handheld terminal
AMS Device Manager (Emerson Process Management)	www.endress.com → Download Area
SIMATIC PDM (Siemens)	www.endress.com → Download Area
Field Communicator 475 (Emerson Process Management)	Use update function of handheld terminal

9.2 Measured variables via HART protocol

The following measured variables (HART device variables) are assigned to the dynamic variables at the factory:

Dynamic variables	Measured variables (HART device variables)
Primary dynamic variable (PV)	Volume flow
Secondary dynamic variable (SV)	Totalizer 1
Tertiary dynamic variable (TV)	Totalizer 2
Quaternary dynamic variable (QV)	Totalizer 3

The assignment of the measured variables to the dynamic variables can be modified and assigned as desired via local operation and the operating tool using the following parameters:

- Expert → Communication → HART output → Output → Assign PV
- Expert → Communication → HART output → Output → Assign SV
- Expert → Communication → HART output → Output → Assign TV
- Expert → Communication → HART output → Output → Assign QV

The following measured variables can be assigned to the dynamic variables:

Measured variables for PV (primary dynamic variable)

- Measured variables which are generally available:
 - Volume flow
 - Mass flow
 - Flow velocity
 - Sound velocity
 - Electronics temperature
- Additional measured variables with the Heartbeat Verification + Monitoring application package:
 - Signal strength
 - Signal to noise ratio
 - Acceptance rate
 - Turbulence

Measured variables for SV, TV, QV (secondary, tertiary and quaternary dynamic variable)

- Measured variables which are always available:
 - Volume flow
 - Mass flow
 - Flow velocity
 - Sound velocity
 - Electronics temperature
 - Totalizer 1
 - Totalizer 2
 - Totalizer 3
 - HART input
 - Current input 1 ⁶⁾
 - Current input 2 ⁶⁾
 - Current input 3 ⁶⁾
- Additional measured variables with the Heartbeat Verification + Monitoring application package:
 - Signal strength
 - Signal to noise ratio
 - Acceptance rate
 - Turbulence

6) Visible depending on the order options or device settings

9.3 Other settings

Burst mode functionality in accordance with HART 7 Specification:

Navigation

"Expert" menu → Communication → HART output → Burst configuration → Burst configuration 1 to n

► Burst configuration 1 to n		
Burst mode 1 to n	→	79
Burst command 1 to n	→	79
Burst variable 0	→	80
Burst variable 1	→	80
Burst variable 2	→	80
Burst variable 3	→	80
Burst variable 4	→	80
Burst variable 5	→	80
Burst variable 6	→	80
Burst variable 7	→	80
Burst trigger mode	→	80
Burst trigger level	→	80
Min. update period	→	80
Max. update period	→	80

Parameter overview with brief description

Parameter	Description	Selection / User entry
Burst mode 1 to n	Activate the HART burst mode for burst message X.	<ul style="list-style-type: none"> ■ Off ■ On
Burst command 1 to n	Select the HART command that is sent to the HART master.	<ul style="list-style-type: none"> ■ Command 1 ■ Command 2 ■ Command 3 ■ Command 9 ■ Command 33 ■ Command 48

Parameter	Description	Selection / User entry
Burst variable 0	For HART command 9 and 33: select the HART device variable or the process variable.	<ul style="list-style-type: none"> ■ Not used ■ Volume flow ■ Mass flow ■ Sound velocity ■ Flow velocity ■ Signal strength * ■ Signal to noise ratio * ■ Turbulence * ■ Acceptance rate * ■ Temperature * ■ Density * ■ Totalizer 1 ■ Totalizer 2 ■ Totalizer 3 ■ Measured current ■ Percent of range ■ Primary variable (PV) ■ Quaternary variable (QV) ■ Secondary variable (SV) ■ Tertiary variable (TV)
Burst variable 1	For HART command 9 and 33: select the HART device variable or the process variable.	See the Burst variable 0 parameter.
Burst variable 2	For HART command 9 and 33: select the HART device variable or the process variable.	See the Burst variable 0 parameter.
Burst variable 3	For HART command 9 and 33: select the HART device variable or the process variable.	See the Burst variable 0 parameter.
Burst variable 4	For HART command 9: select the HART device variable or the process variable.	See the Burst variable 0 parameter.
Burst variable 5	For HART command 9: select the HART device variable or the process variable.	See the Burst variable 0 parameter.
Burst variable 6	For HART command 9: select the HART device variable or the process variable.	See the Burst variable 0 parameter.
Burst variable 7	For HART command 9: select the HART device variable or the process variable.	See the Burst variable 0 parameter.
Burst trigger mode	Select the event that triggers burst message X.	<ul style="list-style-type: none"> ■ Continuous ■ Window * ■ Rising * ■ Falling * ■ On change
Burst trigger level	Enter the burst trigger value. Together with the option selected in the Burst trigger mode parameter the burst trigger value determines the time of burst message X.	Signed floating-point number
Min. update period	Enter the minimum time span between two burst commands of burst message X.	Positive integer
Max. update period	Enter the maximum time span between two burst commands of burst message X.	Positive integer

* Visibility depends on order options or device settings

10 Commissioning

10.1 Function check

Before commissioning the measuring device:

- ▶ Make sure that the post-installation and post-connection checks have been performed.
- "Post-installation check" checklist → 42
- "Post-connection check" checklist → 51

10.2 Switching on the measuring device

- ▶ After a successful function check, switch on the measuring device.
 - ↳ After a successful startup, the local display switches automatically from the startup display to the operational display.

If nothing appears on the local display or a diagnostic message is displayed, refer to the section on "Diagnostics and troubleshooting" → 125.

10.3 Setting the operating language

Factory setting: English or ordered local language

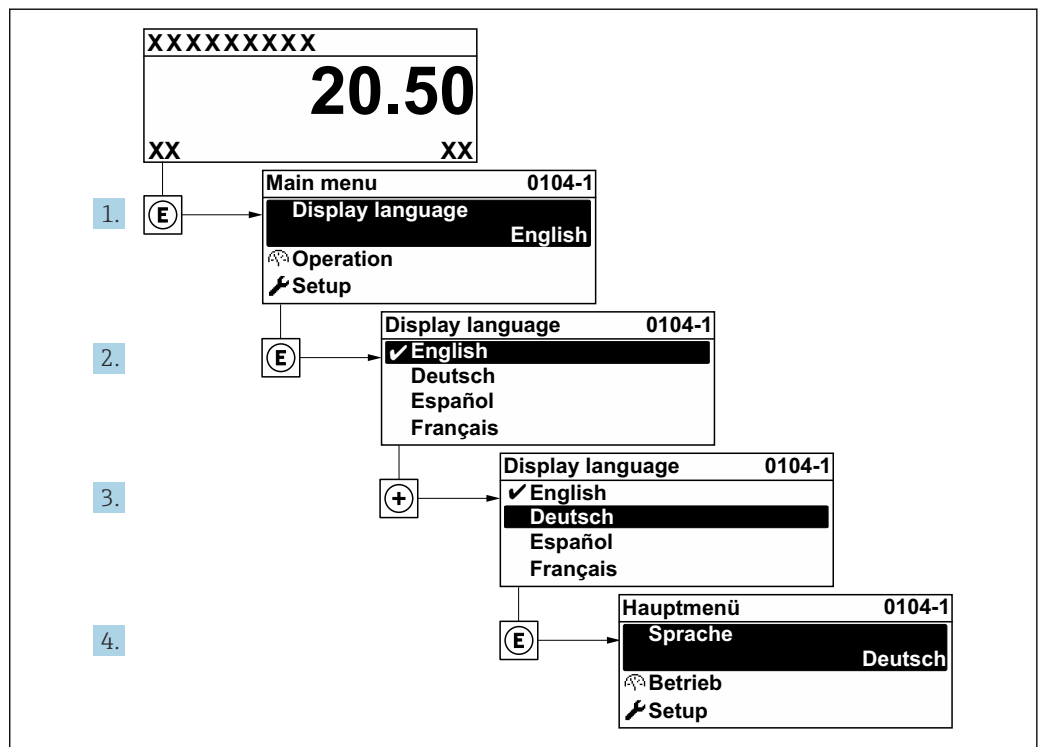

47 Taking the example of the local display

10.4 Configuring the measuring device

- The **Setup** menu with its guided wizards contains all the parameters needed for standard operation.
- Navigation to the **Setup** menu

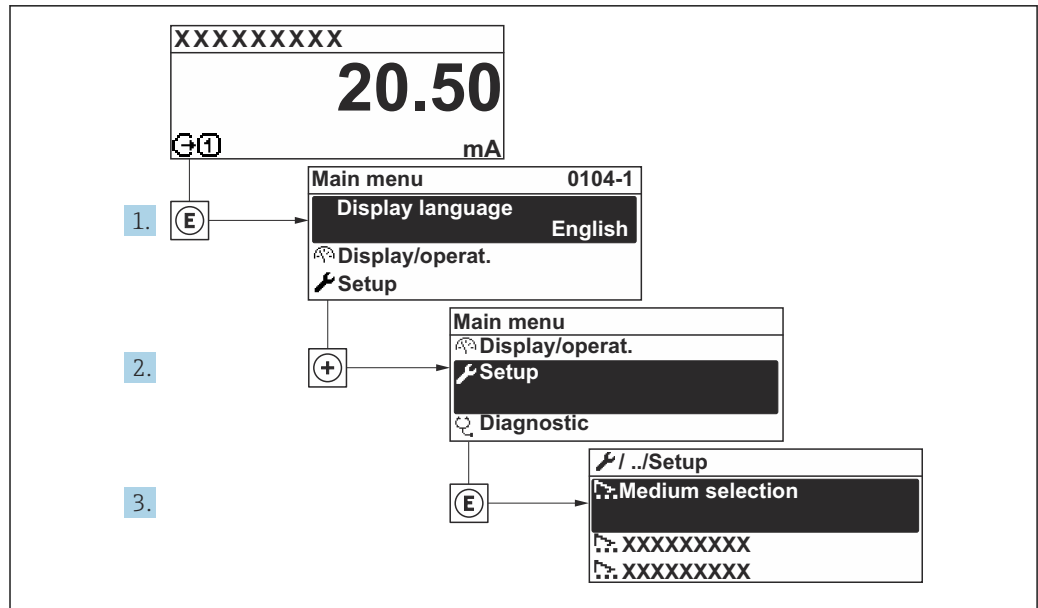

A0032222-EN

48 Taking the example of the local display

i The number of submenus and parameters can vary depending on the device version. Certain submenus and parameters in these submenus are not described in the Operation Instructions. Instead a description is provided in the Special Documentation for the device (→ "Supplementary documentation" section).

🔧 Setup	
Device tag	→ 83
▶ System units	→ 83
▶ Measuring point	→ 84
▶ Installation status	→ 88
▶ Status input 1	→ 89
▶ Current output 1	→ 91
▶ Pulse/frequency/switch output	→ 93
▶ Display	→ 97
▶ Advanced setup	→ 101

10.4.1 Defining the tag name

To enable fast identification of the measuring point within the system, you can enter a unique designation using the **Device tag** parameter and thus change the factory setting.

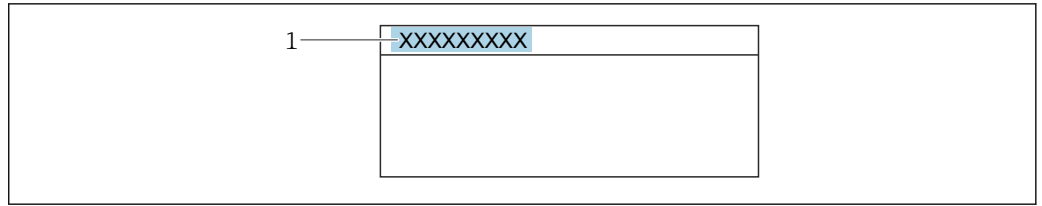

A0029422

49 Header of the operational display with tag name

1 Tag name

i Enter the tag name in the "FieldCare" operating tool → 75

Navigation

"Setup" menu → Device tag

Parameter overview with brief description

Parameter	Description	User entry
Device tag	Enter the name for the measuring point.	Max. 32 characters, such as letters, numbers or special characters (e.g. @, %, /).

10.4.2 Setting the system units

In the **System units** submenu the units of all the measured values can be set.

Navigation

"Setup" menu → System units

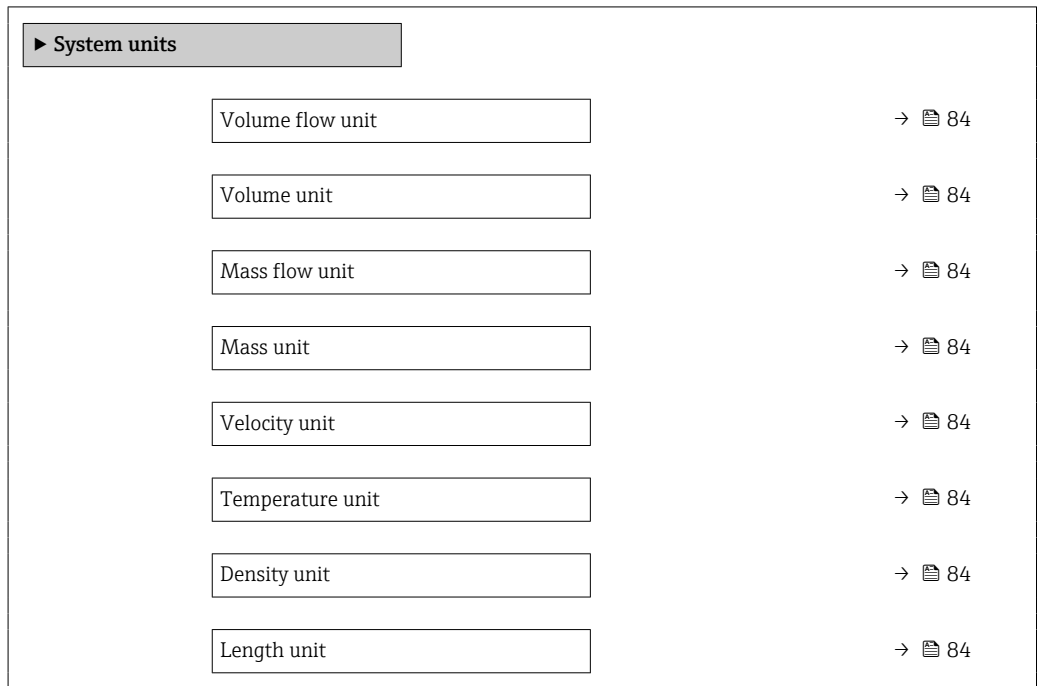

Parameter overview with brief description

Parameter	Description	Selection	Factory setting
Volume flow unit	Select volume flow unit. <i>Effect</i> The selected unit applies for: <ul style="list-style-type: none"> ▪ Output ▪ Low flow cut off ▪ Simulation process variable 	Unit choose list	Country-specific: <ul style="list-style-type: none"> ▪ m³/h ▪ ft³/min
Volume unit	Select volume unit.	Unit choose list	Country-specific: <ul style="list-style-type: none"> ▪ m³ ▪ ft³
Mass flow unit	Select mass flow unit. <i>Effect</i> The selected unit applies for: <ul style="list-style-type: none"> ▪ Output ▪ Low flow cut off ▪ Simulation process variable 	Unit choose list	Country-specific: <ul style="list-style-type: none"> ▪ kg/h ▪ lb/min
Mass unit	Select mass unit.	Unit choose list	Country-specific: <ul style="list-style-type: none"> ▪ kg ▪ lb
Velocity unit	Select velocity unit. <i>Effect</i> The selected unit applies for: <ul style="list-style-type: none"> ▪ Flow velocity ▪ Sound velocity 	Unit choose list	Country-specific: <ul style="list-style-type: none"> ▪ m/s ▪ ft/s
Temperature unit	Select temperature unit. <i>Effect</i> The selected unit applies for: <ul style="list-style-type: none"> ▪ Temperature ▪ Electronic temperature parameter (6053) ▪ External temperature parameter (6080) ▪ Reference temperature parameter (1816) 	Unit choose list	Country-specific: <ul style="list-style-type: none"> ▪ °C ▪ °F
Density unit	Select density unit. <i>Effect</i> The selected unit applies for: <ul style="list-style-type: none"> ▪ Output ▪ Simulation process variable 	Unit choose list	Country-specific: <ul style="list-style-type: none"> ▪ kg/dm³ ▪ lb/ft³
Length unit	Select the unit of length.	Unit choose list	Country-specific: <ul style="list-style-type: none"> ▪ mm ▪ in

10.4.3 Configuring the measuring point

The "**Measuring point**" wizard guides you systematically through all the parameters that must be set for the configuration of the measuring point.

Navigation

"Setup" menu → Measuring point

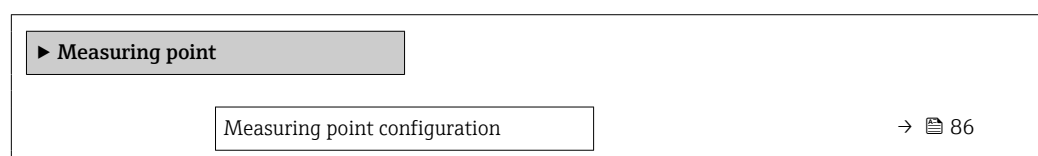

Process fluid	→ 86
Medium temperature	→ 86
Sound velocity	→ 86
Viscosity	→ 86
Pipe material	→ 86
Pipe sound velocity	→ 86
Pipe dimensions	→ 86
Pipe circumference	→ 86
Pipe outer diameter	→ 87
Pipe wall thickness	→ 87
Liner material	→ 87
Liner sound velocity	→ 87
Liner thickness	→ 87
Sensor type	→ 87
Sensor coupling	→ 87
Mounting type	→ 87
Cable length	→ 87
FlowDC inlet configuration	→ 87
Inlet diameter	→ 88
Transition length	→ 88
Inlet run	→ 88
Relative sensor position	→ 88
Result sensor type / mounting type	→ 88
Result sensor distance / measuring aid	→ 88

Parameter overview with brief description

Parameter	Prerequisite	Description	Selection / User entry / User interface	Factory setting
Measuring point configuration	–	Select configuration for the measuring point.	<ul style="list-style-type: none"> ▪ 1 measuring point - signal path 1 ▪ 1 measuring point - signal path 2 * ▪ 1 measuring point - 2 signal paths * 	Depending on the sensor version
Process fluid	–	Select process fluid.	<ul style="list-style-type: none"> ▪ Water ▪ Sea water ▪ Distilled water ▪ Ammonia NH3 ▪ Benzene ▪ Ethanol ▪ Glycol ▪ Milk ▪ Methanol ▪ User-specific liquid 	–
Medium temperature	–	Enter a fixed value for process temperature.	–200 to 550 °C	–
Sound velocity	The User-specific liquid option is selected in the Process fluid parameter.	Enter sound velocity of fluid.	200 to 3000 m/s	–
Viscosity	The User-specific liquid option is selected in the Process fluid parameter.	Enter medium viscosity at installation temperature.	1E-10 to 0.01 m ² /s	–
Pipe material	–	Select pipe material.	<ul style="list-style-type: none"> ▪ Carbon steel ▪ Ductile cast iron ▪ Stainless steel ▪ 1.4301 (UNS S30400) ▪ 1.4401 (UNS S31600) ▪ 1.4550 (UNS S34700) ▪ Hastelloy C ▪ PVC ▪ PE ▪ LDPE ▪ HDPE ▪ GRP ▪ PVDF ▪ PA ▪ PP ▪ PTFE ▪ Pyrex glass ▪ Asbestos cement ▪ Copper ▪ Unknown pipe material 	–
Pipe sound velocity	The Unknown pipe material option is selected in the Pipe material parameter.	Enter sound velocity of pipe material.	800.0 to 3 800.0 m/s	–
Pipe dimensions	–	Select if pipe dimensions are defined by diameter or circumference.	<ul style="list-style-type: none"> ▪ Diameter ▪ Pipe circumference 	–
Pipe circumference	The Pipe circumference option is selected in the Pipe dimensions parameter.	Define the pipe circumference.	30 to 62 800 mm	–

Parameter	Prerequisite	Description	Selection / User entry / User interface	Factory setting
Pipe outer diameter	The Diameter option is selected in the Pipe dimensions parameter.	Define the outer diameter of the pipe.	10 to 5000 mm	100 mm
Pipe wall thickness	–	Enter the pipe wall thickness.	Positive floating point number	3 mm
Liner material	–	Select liner material.	<ul style="list-style-type: none"> ▪ None ▪ Cement ▪ Rubber ▪ Epoxy resin ▪ Unknown liner material 	–
Liner sound velocity	The Unknown liner material option is selected in the Liner material parameter.	Define the sound velocity of liner material.	800.0 to 3800.0 m/s	–
Liner thickness	One of the following options is selected in the Liner material parameter: <ul style="list-style-type: none"> ▪ Cement ▪ Rubber ▪ Epoxy resin ▪ Unknown liner material 	Define the thickness of liner.	0 to 100 mm	–
Sensor type	–	Select sensor type.	<ul style="list-style-type: none"> ▪ C-030-A* ▪ C-050-A* ▪ C-100-A* ▪ C-100-B* ▪ C-100-C* ▪ C-200-A* ▪ C-200-B* ▪ C-200-C* ▪ C-500-A* 	As per order
Sensor coupling	–	Select coupling medium.	<ul style="list-style-type: none"> ▪ Coupling pad ▪ Coupling paste 	–
Mounting type	–	Select how the sensors are arranged to each other. <ul style="list-style-type: none"> ▪ (1) direct option: sensor arrangement with 1 traverse ▪ (2) V-mounting option: sensor arrangement with 2 traverses ▪ (3) Z-Mounting option: sensor arrangement with 3 traverses ▪ (4) W-mounting option: sensor arrangement with 4 traverses 	<ul style="list-style-type: none"> ▪ (1) direct ▪ (2) V-mounting ▪ (3) Z-Mounting ▪ (4) W-mounting ▪ Automatic 	Automatic
Cable length	–	Enter length of sensor cables.	0 to 200000 mm	As per order
FlowDC inlet configuration	<ul style="list-style-type: none"> ▪ The 1 measuring point - 2 signal paths option is selected in the Measuring point configuration parameter. ▪ Order code for "Application package", option EN "FlowDC" has been purchased. 	Select FlowDC inlet configuration.	<ul style="list-style-type: none"> ▪ Off ▪ Single elbow ▪ Double elbow ▪ Double elbow 3D ▪ Concentric diameter change 	–

Parameter	Prerequisite	Description	Selection / User entry / User interface	Factory setting
Inlet diameter	<ul style="list-style-type: none"> The 1 measuring point - 2 signal paths option is selected in the Measuring point configuration parameter. The Concentric diameter change option is selected in the Inlet configuration parameter. 	Enter the outer diameter of the pipe before the cross-section change. For convenience, the same measuring pipe wall thickness as for the clamp-on system is applied.	1 to 10000 mm	–
Transition length	<ul style="list-style-type: none"> The 1 measuring point - 2 signal paths option is selected in the Measuring point configuration parameter. The Concentric diameter change option is selected in the Inlet configuration parameter. 	Enter length of the concentric diameter change.	0 to 20000 mm	–
Inlet run	The 1 measuring point - 2 signal paths option is selected in the Measuring point configuration parameter.	Enter length of the available straight inlet run.	0 to 50000 mm	–
Relative sensor position	The 1 measuring point - 2 signal paths option is selected in the Measuring point configuration parameter.	Shows the correct position for the sensor.	<ul style="list-style-type: none"> 90° 180° 	–
Result sensor type / mounting type	–	Shows the selected sensor type and (if applicable automatically) selected mounting type.	e.g. C-100-A option / (2) V-mounting option	–
Result sensor distance / measuring aid	–	Shows the calculated sensor distance and vernier or wire length (if applicable) required for installation.	e.g. 201.3 mm / B 21	–

* Visibility depends on order options or device settings

10.4.4 Checking the installation status

The status of individual parameters can be checked in the **Installation status** submenu.

Navigation

"Setup" menu → Installation status

► Installation status	
Installation status	→ ⓘ 89
Signal strength	→ ⓘ 89
Signal to noise ratio	→ ⓘ 89
Sound velocity	→ ⓘ 89

Parameter overview with brief description

Parameter	Description	User interface
Installation status	<p>Shows the device status on installation based on the measured values displayed.</p> <p>Displays the device status after installation according to the displayed measured values.</p> <ul style="list-style-type: none"> ▪ Good option: No further optimization required ▪ Acceptable option: Measuring performance ok, optimize if possible. You should always aim for the status Good option. ▪ Bad option: Optimization is required. Poor and unstable measuring performance. <p> Check the following points to optimize the sensor installation:</p> <ul style="list-style-type: none"> ▪ Number of traverses, change if necessary (e.g. from 2 traverses to 1 traverse) ▪ Sensor distance ▪ Alignment of sensors ▪ Sufficient coupling medium available (coupling pad or coupling gel) ▪ Check the measuring point parameters in the configuration 	<ul style="list-style-type: none"> ▪ Good ▪ Acceptable ▪ Bad
Signal strength	<p>Displays the current signal strength (0 to 100 dB).</p> <p>Assessment of the signal strength:</p> <ul style="list-style-type: none"> ▪ < 10 dB: bad ▪ > 90 dB: very good 	Signed floating-point number
Signal to noise ratio	<p>Displays the current signal to noise ratio (0 to 100 dB).</p> <p>Assessment of the signal to noise ratio:</p> <ul style="list-style-type: none"> ▪ < 20 dB: bad ▪ > 50 dB: very good 	Signed floating-point number
Sound velocity	<p>Displays the sound velocity that is currently measured.</p> <p>Assessment of the sound velocity:</p> <ul style="list-style-type: none"> ▪ < 1 %: Good ▪ 1 to 2 %: Acceptable ▪ > 2 %: Bad 	Signed floating-point number

10.4.5 Configuring the status input

The **Status input** submenu guides the user systematically through all the parameters that have to be set for configuring the status input.

 The submenu only appears if the device was ordered with a status input .

Navigation

"Setup" menu → Status input

Structure of the submenu

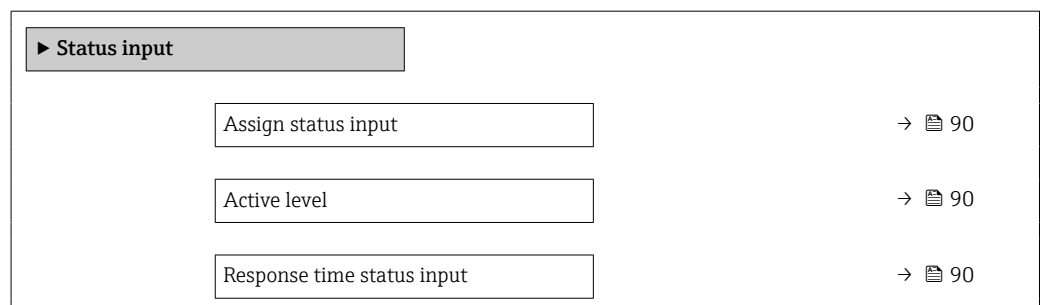

Parameter overview with brief description

Parameter	Description	Selection / User entry
Assign status input	Select function for the status input.	<ul style="list-style-type: none"> ▪ Off ▪ Reset totalizer 1 ▪ Reset totalizer 2 ▪ Reset totalizer 3 ▪ Reset all totalizers ▪ Flow override
Active level	Define input signal level at which the assigned function is triggered.	<ul style="list-style-type: none"> ▪ High ▪ Low
Response time status input	Define the minimum amount of time the input signal level must be present before the selected function is triggered.	5 to 200 ms

10.4.6 Configuring the current output

The **Current output** wizard guides you systematically through all the parameters that have to be set for configuring the current output.

Navigation

"Setup" menu → Current output 1

▶ **Current output 1**

Process variable current output	→ ⓘ 91
Current range output	→ ⓘ 91
Lower range value output	→ ⓘ 92
Upper range value output	→ ⓘ 92
Fixed current	→ ⓘ 92
Damping current output	→ ⓘ 92
Failure behavior current output	→ ⓘ 92
Failure current	→ ⓘ 92

Parameter overview with brief description

Parameter	Prerequisite	Description	Selection / User entry	Factory setting
Process variable current output	–	Select process variable for current output.	<ul style="list-style-type: none"> ■ Off* ■ Volume flow ■ Mass flow ■ Sound velocity ■ Flow velocity ■ Signal strength* ■ Signal to noise ratio* ■ Turbulence* ■ Acceptance rate* ■ Temperature* ■ Density* ■ Electronics temperature 	–
Current range output	–	Select current range for process value output and upper/lower level for alarm signal.	<ul style="list-style-type: none"> ■ 4...20 mA NE (3.8...20.5 mA) ■ 4...20 mA US (3.9...20.8 mA) ■ 4...20 mA (4...20.5 mA) ■ 0...20 mA (0...20.5 mA) ■ Fixed value 	Country-specific: <ul style="list-style-type: none"> ■ 4...20 mA NE (3.8...20.5 mA) ■ 4...20 mA US (3.9...20.8 mA)

Parameter	Prerequisite	Description	Selection / User entry	Factory setting
Lower range value output	One of the following options is selected in the Current span parameter (→ 91): <ul style="list-style-type: none"> 4...20 mA NE (3.8...20.5 mA) 4...20 mA US (3.9...20.8 mA) 4...20 mA (4... 20.5 mA) 0...20 mA (0... 20.5 mA) 	Enter lower range value for the measured value range.	Signed floating-point number	Country-specific: <ul style="list-style-type: none"> m³/h ft³/h
Upper range value output	In the Current span parameter (→ 91), one of the following options is selected: <ul style="list-style-type: none"> 4...20 mA NE (3.8...20.5 mA) 4...20 mA US (3.9...20.8 mA) 4...20 mA (4... 20.5 mA) 0...20 mA (0... 20.5 mA) 	Enter upper range value for the measured value range.	Signed floating-point number	Depends on country and nominal diameter
Fixed current	The Fixed current option is selected in the Current span parameter (→ 91).	Defines the fixed output current.	0 to 22.5 mA	22.5 mA
Damping current output	A process variable is selected in the Assign current output parameter (→ 91) and one of the following options is selected in the Current span parameter (→ 91): <ul style="list-style-type: none"> 4...20 mA NE (3.8...20.5 mA) 4...20 mA US (3.9...20.8 mA) 4...20 mA (4... 20.5 mA) 0...20 mA (0... 20.5 mA) 	Set reaction time for output signal to fluctuations in the measured value.	0.0 to 999.9 s	–
Failure behavior current output	A process variable is selected in the Assign current output parameter (→ 91) and one of the following options is selected in the Current span parameter (→ 91): <ul style="list-style-type: none"> 4...20 mA NE (3.8...20.5 mA) 4...20 mA US (3.9...20.8 mA) 4...20 mA (4... 20.5 mA) 0...20 mA (0... 20.5 mA) 	Define output behavior in alarm condition.	<ul style="list-style-type: none"> Min. Max. Last valid value Actual value Fixed value 	–
Failure current	The Defined value option is selected in the Failure mode parameter.	Enter current output value in alarm condition.	0 to 22.5 mA	–

* Visibility depends on order options or device settings

10.4.7 Configuring the pulse/frequency/switch output

The **Pulse/frequency/switch output** wizard guides you systematically through all the parameters that can be set for configuring the selected output type.

Configuring the pulse output

Navigation

"Setup" menu → Pulse/frequency/switch output 1 to n

► **Pulse/frequency/switch output 1 to n**

Operating mode	→ 93
Assign pulse output	→ 93
Value per pulse	→ 93
Pulse width	→ 93
Failure mode	→ 93
Invert output signal	→ 93

Parameter overview with brief description

Parameter	Prerequisite	Description	Selection / User entry	Factory setting
Operating mode	–	Define the output as a pulse, frequency or switch output.	<ul style="list-style-type: none"> ■ Pulse * ■ Frequency * ■ Switch * 	–
Assign pulse output	The Pulse option is selected in the Operating mode parameter.	Select process variable for pulse output.	<ul style="list-style-type: none"> ■ Off ■ Volume flow ■ Mass flow 	–
Pulse scaling	The Pulse option is selected in the Operating mode parameter (→ 93) and a process variable is selected in the Assign pulse output parameter (→ 93).	Enter quantity for measured value at which a pulse is output.	Positive floating point number	Depends on country and nominal diameter
Pulse width	The Pulse option is selected in the Operating mode parameter (→ 93) and a process variable is selected in the Assign pulse output parameter (→ 93).	Define time width of the output pulse.	0.05 to 2 000 ms	–
Failure mode	The Pulse option is selected in the Operating mode parameter (→ 93) and a process variable is selected in the Assign pulse output parameter (→ 93).	Define output behavior in alarm condition.	<ul style="list-style-type: none"> ■ Actual value ■ No pulses 	–
Invert output signal	–	Invert the output signal.	<ul style="list-style-type: none"> ■ No ■ Yes 	–

* Visibility depends on order options or device settings

Configuring the frequency output

Navigation

"Setup" menu → Pulse/frequency/switch output 1 to n

► Pulse/frequency/switch output 1 to n	
Operating mode	→ 94
Assign frequency output	→ 94
Minimum frequency value	→ 94
Maximum frequency value	→ 95
Measuring value at minimum frequency	→ 95
Measuring value at maximum frequency	→ 95
Failure mode	→ 95
Failure frequency	→ 95
Invert output signal	→ 95

Parameter overview with brief description

Parameter	Prerequisite	Description	Selection / User entry	Factory setting
Operating mode	–	Define the output as a pulse, frequency or switch output.	<ul style="list-style-type: none"> ▪ Pulse * ▪ Frequency * ▪ Switch * 	–
Assign frequency output	The Frequency option is selected in the Operating mode parameter (→ 93).	Select process variable for frequency output.	<ul style="list-style-type: none"> ▪ Off ▪ Volume flow ▪ Mass flow ▪ Sound velocity ▪ Flow velocity ▪ Signal strength * ▪ Signal to noise ratio * ▪ Turbulence * ▪ Acceptance rate * ▪ Temperature * ▪ Density * ▪ Electronics temperature 	–
Minimum frequency value	The Frequency option is selected in the Operating mode parameter (→ 93) and a process variable is selected in the Assign frequency output parameter (→ 94).	Enter minimum frequency.	0.0 to 10 000 Hz	–

Parameter	Prerequisite	Description	Selection / User entry	Factory setting
Maximum frequency value	The Frequency option is selected in the Operating mode parameter (→ 93) and a process variable is selected in the Assign frequency output parameter (→ 94).	Enter maximum frequency.	0.0 to 10000 Hz	–
Measuring value at minimum frequency	The Frequency option is selected in the Operating mode parameter (→ 93) and a process variable is selected in the Assign frequency output parameter (→ 94).	Enter measured value for minimum frequency.	Signed floating-point number	Depends on country and nominal diameter
Measuring value at maximum frequency	The Frequency option is selected in the Operating mode parameter (→ 93) and a process variable is selected in the Assign frequency output parameter (→ 94).	Enter measured value for maximum frequency.	Signed floating-point number	Depends on country and nominal diameter
Failure mode	The Frequency option is selected in the Operating mode parameter (→ 93) and a process variable is selected in the Assign frequency output parameter (→ 94).	Define output behavior in alarm condition.	<ul style="list-style-type: none"> ■ Actual value ■ Defined value ■ 0 Hz 	–
Failure frequency	The Frequency option is selected in the Operating mode parameter (→ 93) and a process variable is selected in the Assign frequency output parameter (→ 94).	Enter frequency output value in alarm condition.	0.0 to 12500.0 Hz	–
Invert output signal	–	Invert the output signal.	<ul style="list-style-type: none"> ■ No ■ Yes 	–

* Visibility depends on order options or device settings









Configuring the switch output

Navigation

"Setup" menu → Pulse/frequency/switch output 1 to n

► Pulse/frequency/switch output 1 to n

Operating mode	→ 96
Switch output function	→ 96
Assign diagnostic behavior	→ 96
Assign limit	→ 96

Assign flow direction check	→  97
Assign status	→  97
Switch-on value	→  97
Switch-off value	→  97
Switch-on delay	→  97
Switch-off delay	→  97
Failure mode	→  97
Invert output signal	→  97

Parameter overview with brief description

Parameter	Prerequisite	Description	Selection / User entry	Factory setting
Operating mode	–	Define the output as a pulse, frequency or switch output.	<ul style="list-style-type: none"> ▪ Pulse * ▪ Frequency * ▪ Switch * 	–
Switch output function	The Switch option is selected in the Operating mode parameter.	Select function for switch output.	<ul style="list-style-type: none"> ▪ Off ▪ On ▪ Diagnostic behavior ▪ Limit ▪ Flow direction check ▪ Status 	–
Assign diagnostic behavior	<ul style="list-style-type: none"> ▪ In the Operating mode parameter, the Switch option is selected. ▪ In the Switch output function parameter, the Diagnostic behavior option is selected. 	Select diagnostic behavior for switch output.	<ul style="list-style-type: none"> ▪ Alarm ▪ Alarm or warning ▪ Warning 	–
Assign limit	<ul style="list-style-type: none"> ▪ The Switch option is selected in the Operating mode parameter. ▪ The Limit option is selected in the Switch output function parameter. 	Select process variable for limit function.	<ul style="list-style-type: none"> ▪ Off ▪ Volume flow ▪ Mass flow ▪ Sound velocity ▪ Flow velocity ▪ Signal strength * ▪ Signal to noise ratio * ▪ Turbulence * ▪ Acceptance rate * ▪ Temperature * ▪ Density * ▪ Electronics temperature ▪ Totalizer 1 ▪ Totalizer 2 ▪ Totalizer 3 	–

Parameter	Prerequisite	Description	Selection / User entry	Factory setting
Assign flow direction check	<ul style="list-style-type: none"> The Switch option is selected in the Operating mode parameter. The Flow direction check option is selected in the Switch output function parameter. 	Select process variable for flow direction monitoring.	<ul style="list-style-type: none"> Off Volume flow Mass flow Flow velocity 	–
Assign status	<ul style="list-style-type: none"> The Switch option is selected in the Operating mode parameter. The Status option is selected in the Switch output function parameter. 	Select device status for switch output.	<ul style="list-style-type: none"> Off Low flow cut off 	–
Switch-on value	<ul style="list-style-type: none"> The Switch option is selected in the Operating mode parameter. The Limit option is selected in the Switch output function parameter. 	Enter measured value for the switch-on point.	Signed floating-point number	Country-specific
Switch-off value	<ul style="list-style-type: none"> The Switch option is selected in the Operating mode parameter. The Limit option is selected in the Switch output function parameter. 	Enter measured value for the switch-off point.	Signed floating-point number	Country-specific
Switch-on delay	<ul style="list-style-type: none"> The Switch option is selected in the Operating mode parameter. The Limit option is selected in the Switch output function parameter. 	Define delay for the switch-on of status output.	0.0 to 100.0 s	–
Switch-off delay	<ul style="list-style-type: none"> The Switch option is selected in the Operating mode parameter. The Limit option is selected in the Switch output function parameter. 	Define delay for the switch-off of status output.	0.0 to 100.0 s	–
Failure mode	–	Define output behavior in alarm condition.	<ul style="list-style-type: none"> Actual status Open Closed 	–
Invert output signal	–	Invert the output signal.	<ul style="list-style-type: none"> No Yes 	–

* Visibility depends on order options or device settings







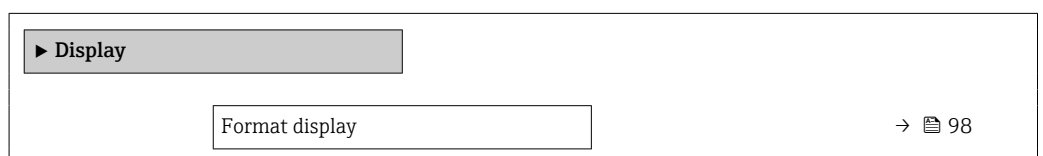

10.4.8 Configuring the local display

The **Display** wizard guides you systematically through all the parameters that can be configured for configuring the local display.

Navigation

"Setup" menu → Display



Value 1 display	→  98
0% bargraph value 1	→  98
100% bargraph value 1	→  98
Value 2 display	→  98
Value 3 display	→  98
0% bargraph value 3	→  98
100% bargraph value 3	→  99
Value 4 display	→  99

Parameter overview with brief description

Parameter	Prerequisite	Description	Selection / User entry	Factory setting
Format display	A local display is provided.	Select how measured values are shown on the display.	<ul style="list-style-type: none"> ▪ 1 value, max. size ▪ 1 bargraph + 1 value ▪ 2 values ▪ 1 value large + 2 values ▪ 4 values 	1 value, max. size
Value 1 display	A local display is provided.	Select the measured value that is shown on the local display.	<ul style="list-style-type: none"> ▪ Volume flow ▪ Mass flow ▪ Sound velocity ▪ Flow velocity ▪ Signal strength * ▪ Signal to noise ratio * ▪ Turbulence * ▪ Acceptance rate * ▪ Temperature * ▪ Density * ▪ Electronics temperature ▪ Totalizer 1 ▪ Totalizer 2 ▪ Totalizer 3 ▪ Current output 1 	Volume flow
0% bargraph value 1	A local display is provided.	Enter 0% value for bar graph display.	Signed floating-point number	Country-specific
100% bargraph value 1	A local display is provided.	Enter 100% value for bar graph display.	Signed floating-point number	Depends on country and nominal diameter
Value 2 display	A local display is provided.	Select the measured value that is shown on the local display.	Picklist, see Value 1 display parameter	–
Value 3 display	A local display is provided.	Select the measured value that is shown on the local display.	Picklist, see Value 1 display parameter	–
0% bargraph value 3	A selection was made in the Value 3 display parameter.	Enter 0% value for bar graph display.	Signed floating-point number	Country-specific

Parameter	Prerequisite	Description	Selection / User entry	Factory setting
100% bargraph value 3	A selection was made in the Value 3 display parameter.	Enter 100% value for bar graph display.	Signed floating-point number	-
Value 4 display	A local display is provided.	Select the measured value that is shown on the local display.	Picklist, see Value 1 display parameter	-

* Visibility depends on order options or device settings

10.4.9 Configuring the low flow cut off

The **Low flow cut off** wizard systematically guides the user through all the parameters that must be set to configure low flow cut off.

Structure of the wizard

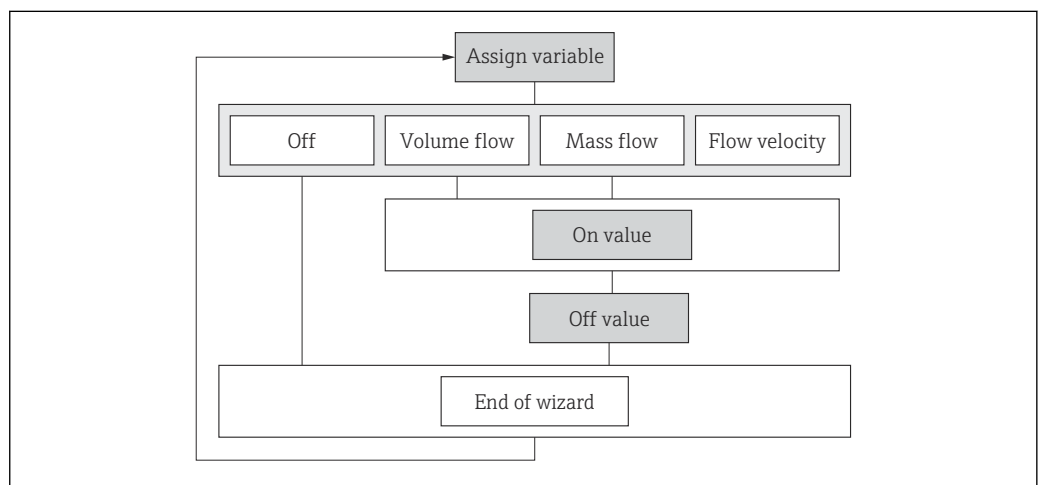

50 "Low flow cutoff" wizard in the "Setup" menu



Navigation

"Setup" menu → Low flow cut off

▶ **Low flow cut off**

Assign process variable	→ 100
On value low flow cutoff	→ 100
Off value low flow cutoff	→ 100

Parameter overview with brief description

Parameter	Prerequisite	Description	Selection / User entry	Factory setting
Assign process variable	–	Select process variable for low flow cut off.	<ul style="list-style-type: none"> ▪ Off ▪ Volume flow ▪ Mass flow ▪ Flow velocity 	Flow velocity
On value low flow cutoff	A process variable is selected in the Assign process variable parameter (→  100).	Enter on value for low flow cut off.	Positive floating-point number	0.3 m/s
Off value low flow cutoff	A process variable is selected in the Assign process variable parameter (→  100).	Enter off value for low flow cut off.	0 to 100.0 %	–

10.5 Advanced settings

The **Advanced setup** submenu together with its submenus contains parameters for specific settings.

Navigation to the "Advanced setup" submenu

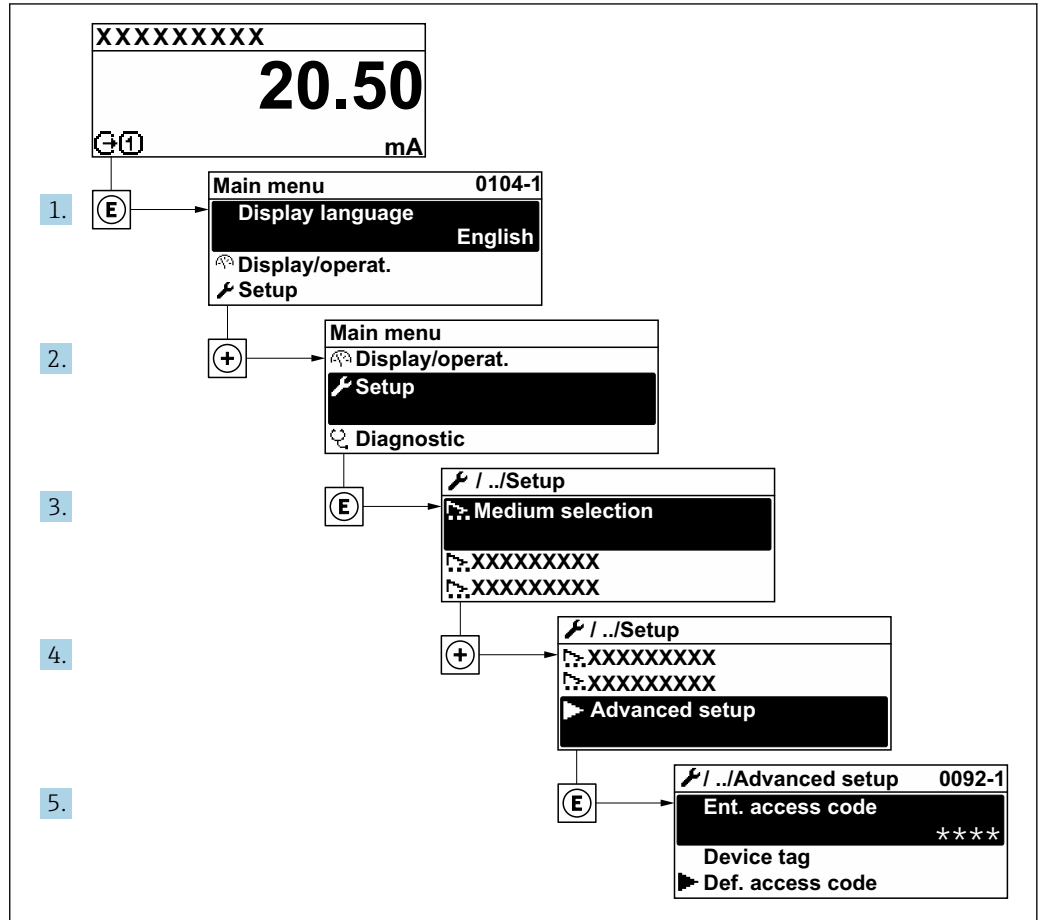

A003223-EN

i The number of submenus and parameters can vary depending on the device version. Certain submenus and parameters in these submenus are not described in the Operation Instructions. Instead a description is provided in the Special Documentation for the device (→ "Supplementary documentation" section).

Navigation

"Setup" menu → Advanced setup

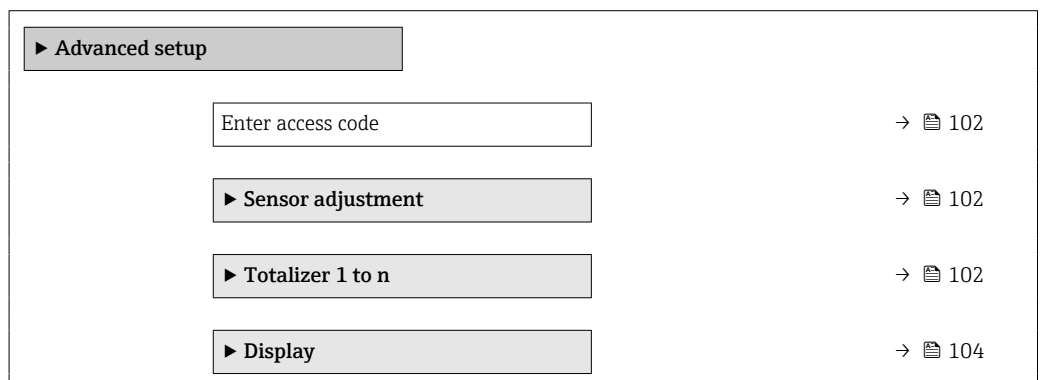

▶ WLAN settings	→ 106
▶ Heartbeat setup	→ 108
▶ Administration	→ 109

10.5.1 Using the parameter to enter the access code

Navigation

"Setup" menu → Advanced setup

Parameter overview with brief description

Parameter	Description	User entry
Enter access code	Enter access code to disable write protection of parameters.	Max. 16-digit character string comprising numbers, letters and special characters

10.5.2 Carrying out a sensor adjustment

The **Sensor adjustment** submenu contains parameters that pertain to the functionality of the sensor.

Navigation

"Setup" menu → Advanced setup → Sensor adjustment

▶ Sensor adjustment	
Installation direction	→ 102

Parameter overview with brief description

Parameter	Description	Selection
Installation direction	Select sign of flow direction.	<ul style="list-style-type: none"> ▪ Forward flow ▪ Reverse flow

10.5.3 Configuring the totalizer

In the "**Totalizer 1 to n**" submenu the individual totalizer can be configured.

Navigation

"Setup" menu → Advanced setup → Totalizer 1 to n

▶ Totalizer 1 to n	
Assign process variable	→ 103
Unit totalizer 1 to n	→ 103

Totalizer operation mode	→ 103
Failure mode	→ 103

Parameter overview with brief description

Parameter	Prerequisite	Description	Selection	Factory setting
Assign process variable	–	Select process variable for totalizer.	<ul style="list-style-type: none"> ■ Off ■ Volume flow ■ Mass flow 	Volume flow
Unit totalizer 1 to n	A process variable is selected in the Assign process variable parameter (→ 103) of the Totalizer 1 to n submenu.	Select the unit for the process variable of the totalizer.	<ul style="list-style-type: none"> ■ g[*] ■ kg[*] ■ t[*] ■ oz[*] ■ lb[*] ■ STon[*] ■ cm³[*] ■ dm³[*] ■ m³[*] ■ ml[*] ■ l[*] ■ hl[*] ■ Ml Mega[*] ■ af[*] ■ ft³[*] ■ Mft³[*] ■ Mft³[*] ■ fl oz (us)[*] ■ gal (us)[*] ■ kgal (us)[*] ■ Mgal (us)[*] ■ bbl (us;liq.)[*] ■ bbl (us;beer)[*] ■ bbl (us;oil)[*] ■ bbl (us;tank)[*] ■ gal (imp)[*] ■ Mgal (imp)[*] ■ bbl (imp;beer)[*] ■ bbl (imp;oil)[*] ■ None[*] 	Country-specific: <ul style="list-style-type: none"> ■ m³ ■ ft³
Totalizer operation mode	A process variable is selected in the Assign process variable parameter (→ 103) of the Totalizer 1 to n submenu.	Select totalizer calculation mode.	<ul style="list-style-type: none"> ■ Net flow total ■ Forward flow total ■ Reverse flow total 	Net flow total
Failure mode	A process variable is selected in the Assign process variable parameter (→ 103) of the Totalizer 1 to n submenu.	Select totalizer behavior in the event of a device alarm.	<ul style="list-style-type: none"> ■ Stop ■ Actual value ■ Last valid value 	Stop

* Visibility depends on order options or device settings

10.5.4 Carrying out additional display configurations

In the **Display** submenu you can set all the parameters associated with the configuration of the local display.

Navigation

"Setup" menu → Advanced setup → Display

► Display	
Format display	→ 105
Value 1 display	→ 105
0% bargraph value 1	→ 105
100% bargraph value 1	→ 105
Decimal places 1	→ 105
Value 2 display	→ 105
Decimal places 2	→ 105
Value 3 display	→ 105
0% bargraph value 3	→ 105
100% bargraph value 3	→ 105
Decimal places 3	→ 105
Value 4 display	→ 105
Decimal places 4	→ 106
Display language	→ 106
Display interval	→ 106
Display damping	→ 106
Header	→ 106
Header text	→ 106
Separator	→ 106
Backlight	→ 106

Parameter overview with brief description

Parameter	Prerequisite	Description	Selection / User entry	Factory setting
Format display	A local display is provided.	Select how measured values are shown on the display.	<ul style="list-style-type: none"> ■ 1 value, max. size ■ 1 bargraph + 1 value ■ 2 values ■ 1 value large + 2 values ■ 4 values 	1 value, max. size
Value 1 display	A local display is provided.	Select the measured value that is shown on the local display.	<ul style="list-style-type: none"> ■ Volume flow ■ Mass flow ■ Sound velocity ■ Flow velocity ■ Signal strength * ■ Signal to noise ratio * ■ Turbulence * ■ Acceptance rate * ■ Temperature * ■ Density * ■ Electronics temperature ■ Totalizer 1 ■ Totalizer 2 ■ Totalizer 3 ■ Current output 1 	Volume flow
0% bargraph value 1	A local display is provided.	Enter 0% value for bar graph display.	Signed floating-point number	Country-specific
100% bargraph value 1	A local display is provided.	Enter 100% value for bar graph display.	Signed floating-point number	Depends on country and nominal diameter
Decimal places 1	A measured value is defined in the Value 1 display parameter.	Select the number of decimal places for the display value.	<ul style="list-style-type: none"> ■ x ■ x.x ■ x.xx ■ x.xxx ■ x.xxxx 	x.xx
Value 2 display	A local display is provided.	Select the measured value that is shown on the local display.	Picklist, see Value 1 display parameter	–
Decimal places 2	A measured value is specified in the Value 2 display parameter.	Select the number of decimal places for the display value.	<ul style="list-style-type: none"> ■ x ■ x.x ■ x.xx ■ x.xxx ■ x.xxxx 	–
Value 3 display	A local display is provided.	Select the measured value that is shown on the local display.	Picklist, see Value 1 display parameter	–
0% bargraph value 3	A selection was made in the Value 3 display parameter.	Enter 0% value for bar graph display.	Signed floating-point number	Country-specific
100% bargraph value 3	A selection was made in the Value 3 display parameter.	Enter 100% value for bar graph display.	Signed floating-point number	–
Decimal places 3	A measured value is specified in the Value 3 display parameter.	Select the number of decimal places for the display value.	<ul style="list-style-type: none"> ■ x ■ x.x ■ x.xx ■ x.xxx ■ x.xxxx 	–
Value 4 display	A local display is provided.	Select the measured value that is shown on the local display.	Picklist, see Value 1 display parameter	–

Parameter	Prerequisite	Description	Selection / User entry	Factory setting
Decimal places 4	A measured value is specified in the Value 4 display parameter.	Select the number of decimal places for the display value.	<ul style="list-style-type: none"> ▪ x ▪ x.x ▪ x.xx ▪ x.xxx ▪ x.xxxx 	–
Display language	A local display is provided.	Set display language.	<ul style="list-style-type: none"> ▪ English ▪ Deutsch ▪ Français ▪ Español ▪ Italiano ▪ Nederlands ▪ Portuguesa ▪ Polski ▪ русский язык (Russian) ▪ Svenska ▪ Türkçe ▪ 中文 (Chinese) ▪ 日本語 (Japanese) ▪ 한국어 (Korean) ▪ Bahasa Indonesia ▪ tiếng Việt (Vietnamese) ▪ čeština (Czech) 	English (alternatively, the ordered language is preset in the device)
Display interval	A local display is provided.	Set time measured values are shown on display if display alternates between values.	1 to 10 s	–
Display damping	A local display is provided.	Set display reaction time to fluctuations in the measured value.	0.0 to 999.9 s	–
Header	A local display is provided.	Select header contents on local display.	<ul style="list-style-type: none"> ▪ Device tag ▪ Free text 	–
Header text	In the Header parameter, the Free text option is selected.	Enter display header text.	Max. 12 characters such as letters, numbers or special characters (e.g. @, %, /)	–
Separator	A local display is provided.	Select decimal separator for displaying numerical values.	<ul style="list-style-type: none"> ▪ . (point) ▪ , (comma) 	. (point)
Backlight	A local display is provided.	Switch the local display backlight on and off.	<ul style="list-style-type: none"> ▪ Disable ▪ Enable 	–

* Visibility depends on order options or device settings

10.5.5 WLAN configuration

The **WLAN Settings** submenu guides the user systematically through all the parameters that have to be set for the WLAN configuration.

Navigation



"Setup" menu → Advanced setup → WLAN settings

▶ WLAN settings	
WLAN	→ ⓘ 107
WLAN mode	→ ⓘ 107

SSID name	→ ⓘ 107
Network security	→ ⓘ 107
Security identification	→ ⓘ 107
User name	→ ⓘ 107
WLAN password	→ ⓘ 107
WLAN IP address	→ ⓘ 107
WLAN MAC address	→ ⓘ 108
WLAN passphrase	→ ⓘ 108
Assign SSID name	→ ⓘ 108
SSID name	→ ⓘ 108
Connection state	→ ⓘ 108
Received signal strength	→ ⓘ 108

Parameter overview with brief description

Parameter	Prerequisite	Description	Selection / User entry / User interface	Factory setting
WLAN	–	Switch WLAN on and off.	<ul style="list-style-type: none"> ■ Disable ■ Enable 	–
WLAN mode	–	Select WLAN mode.	WLAN access point	–
SSID name	The client is activated.	Enter the user-defined SSID name (max. 32 characters).	–	–
Network security	–	Select the security type of the WLAN network.	<ul style="list-style-type: none"> ■ Unsecured ■ WPA2-PSK ■ EAP-PEAP with MSCHAPv2 * ■ EAP-PEAP MSCHAPv2 no server authentic. * ■ EAP-TLS * 	–
Security identification	–	Select security settings and download these settings via menu Data management > Security > WLAN.	<ul style="list-style-type: none"> ■ Trusted issuer certificate ■ Device certificate ■ Device private key 	–
User name	–	Enter user name.	–	–
WLAN password	–	Enter WLAN password.	–	–
WLAN IP address	–	Enter IP address of the WLAN interface of the device.	4 octet: 0 to 255 (in the particular octet)	–

Parameter	Prerequisite	Description	Selection / User entry / User interface	Factory setting
WLAN MAC address	–	Enter MAC address of the WLAN interface of the device.	Unique 12-digit character string comprising letters and numbers	Each measuring device is given an individual address.
WLAN passphrase	The WPA2-PSK option is selected in the Security type parameter.	Enter the network key (8 to 32 characters).  The network key supplied with the device should be changed during commissioning for security reasons.	8 to 32-digit character string comprising numbers, letters and special characters (without spaces)	Serial number of the measuring device (e.g. L100A802000)
Assign SSID name	–	Select which name will be used for SSID: device tag or user-defined name.	<ul style="list-style-type: none"> ▪ Device tag ▪ User-defined 	–
SSID name	<ul style="list-style-type: none"> ▪ The User-defined option is selected in the Assign SSID name parameter. ▪ The WLAN access point option is selected in the WLAN mode parameter. 	Enter the user-defined SSID name (max. 32 characters).  The user-defined SSID name may only be assigned once. If the SSID name is assigned more than once, the devices can interfere with one another.	Max. 32-digit character string comprising numbers, letters and special characters	EH_device designation_last 7 digits of the serial number (e.g. EH_Prosonic_Flow_400_A802000)
Connection state	–	Displays the connection status.	<ul style="list-style-type: none"> ▪ Connected ▪ Not connected 	–
Received signal strength	–	Shows the received signal strength.	<ul style="list-style-type: none"> ▪ Low ▪ Medium ▪ High 	–
Apply changes	–	Use changed WLAN settings.	<ul style="list-style-type: none"> ▪ Cancel ▪ Ok 	–

* Visibility depends on order options or device settings

10.5.6 Performing Heartbeat basic setup

Heartbeat setup submenu guides the user systematically through all the parameters that can be used for the Heartbeat basic setup.

 The wizard only appears if the device has the Heartbeat Verification +Monitoring application package.

Navigation

"Setup" menu → Advanced setup → Heartbeat setup

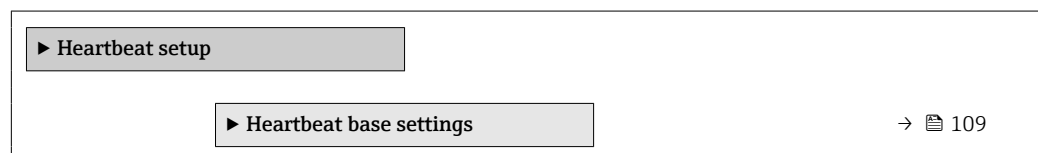

"Heartbeat base settings" submenu

Navigation

"Setup" menu → Advanced setup → Heartbeat setup → Heartbeat base settings

▶ Heartbeat base settings

Plant operator

→ ⓘ 109

Location

→ ⓘ 109

Parameter overview with brief description

Parameter	Description	User entry
Plant operator	Enter the plant operator.	Max. 32 characters such as letters, numbers or special characters (e.g. @, %, /)
Location	Enter the location.	Max. 32 characters such as letters, numbers or special characters (e.g. @, %, /)

10.5.7 Using parameters for device administration

The **Administration** submenu systematically guides the user through all the parameters that can be used for device administration purposes.

Navigation

"Setup" menu → Advanced setup → Administration

▶ Administration

▶ Define access code

→ ⓘ 109

▶ Reset access code

→ ⓘ 110

Device reset

→ ⓘ 110

Using the parameter to define the access code

Navigation

"Setup" menu → Advanced setup → Administration → Define access code

▶ Define access code

Define access code

→ ⓘ 110

Confirm access code

→ ⓘ 110

Parameter overview with brief description

Parameter	Description	User entry
Define access code	Restrict write-access to parameters to protect the configuration of the device against unintentional changes.	Max. 16-digit character string comprising numbers, letters and special characters
Confirm access code	Confirm the entered access code.	Max. 16-digit character string comprising numbers, letters and special characters

Using the parameter to reset the access code

Navigation

"Setup" menu → Advanced setup → Administration → Reset access code

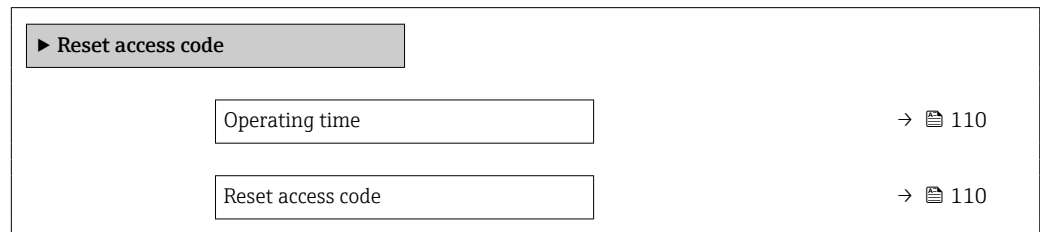

Parameter overview with brief description

Parameter	Description	User interface / User entry
Operating time	Indicates how long the device has been in operation.	Days (d), hours (h), minutes (m) and seconds (s)
Reset access code	<p>Reset access code to factory settings.</p> <p> For a reset code, contact your Endress+Hauser service organization.</p> <p>The reset code can only be entered via:</p> <ul style="list-style-type: none"> ▪ Web browser ▪ DeviceCare, FieldCare (via CDI-RJ45 service interface) ▪ Fieldbus 	Character string comprising numbers, letters and special characters

Using the parameter to reset the device

Navigation

"Setup" menu → Advanced setup → Administration

Parameter overview with brief description

Parameter	Description	Selection
Device reset	Reset the device configuration - either entirely or in part - to a defined state.	<ul style="list-style-type: none"> ▪ Cancel ▪ To delivery settings ▪ Restart device ▪ Restore S-DAT backup *

* Visibility depends on order options or device settings















10.6 Simulation

The **Simulation** submenu enables you to simulate, without a real flow situation, various process variables in the process and the device alarm mode and to verify downstream signal chains (switching valves or closed-control loops).



-  The parameters displayed depend on:
- The selected device order
 - The set operating mode of the pulse/frequency/switch outputs

Navigation

"Diagnostics" menu → Simulation

► Simulation	
Assign simulation process variable	→  112
Process variable value	→  112
Status input simulation 1	→  112
Input signal level 1	→  112
Current output 1 simulation	→  112
Current output value	→  112
Frequency output 1 to n simulation	→  112
Frequency output 1 to n value	→  112
Pulse output simulation 1 to n	→  112
Pulse value 1 to n	→  112
Switch output simulation 1 to n	→  112
Switch state 1 to n	→  112
Device alarm simulation	→  112
Diagnostic event category	→  112
Diagnostic event simulation	→  112

Parameter overview with brief description

Parameter	Prerequisite	Description	Selection / User entry
Assign simulation process variable	–	Select a process variable for the simulation process that is activated.	<ul style="list-style-type: none"> ■ Off ■ Volume flow ■ Mass flow ■ Sound velocity ■ Flow velocity ■ Temperature * ■ Density *
Process variable value	A process variable is selected in the Assign simulation process variable parameter (→  112).	Enter the simulation value for the selected process variable.	Depends on the process variable selected
Status input simulation 1	For the following order code: "Output; input", option I "4-20mA HART, 2x pul./freq./switch output; status input"	Switch simulation of the status input on and off.	<ul style="list-style-type: none"> ■ Off ■ On
Input signal level 1	In the Status input simulation parameter, the On option is selected.	Select the signal level for the simulation of the status input.	<ul style="list-style-type: none"> ■ High ■ Low
Current output 1 simulation	–	Switch the simulation of the current output on and off.	<ul style="list-style-type: none"> ■ Off ■ On
Current output value	In the Current output simulation parameter, the On option is selected.	Enter the current value for simulation.	3.59 to 22.5 mA
Frequency output 1 to n simulation	In the Operating mode parameter, the Frequency option is selected.	Switch the simulation of the frequency output on and off.	<ul style="list-style-type: none"> ■ Off ■ On
Frequency output 1 to n value	In the Frequency simulation 1 to n parameter, the On option is selected.	Enter the frequency value for the simulation.	0.0 to 12 500.0 Hz
Pulse output simulation 1 to n	In the Operating mode parameter, the Pulse option is selected.	Set and switch off the pulse output simulation.  For Fixed value option: Pulse width parameter (→  93) defines the pulse width of the pulses output.	<ul style="list-style-type: none"> ■ Off ■ Fixed value ■ Down-counting value
Pulse value 1 to n	In the Pulse output simulation 1 to n parameter, the Down-counting value option is selected.	Enter the number of pulses for simulation.	0 to 65 535
Switch output simulation 1 to n	In the Operating mode parameter, the Switch option is selected.	Switch the simulation of the switch output on and off.	<ul style="list-style-type: none"> ■ Off ■ On
Switch state 1 to n	–	Select the status of the status output for the simulation.	<ul style="list-style-type: none"> ■ Open ■ Closed
Device alarm simulation	–	Switch the device alarm on and off.	<ul style="list-style-type: none"> ■ Off ■ On
Diagnostic event category	–	Select a diagnostic event category.	<ul style="list-style-type: none"> ■ Sensor ■ Electronics ■ Configuration ■ Process
Diagnostic event simulation	–	Select a diagnostic event to simulate this event.	<ul style="list-style-type: none"> ■ Off ■ Diagnostic event picklist (depends on the category selected)

* Visibility depends on order options or device settings

10.7 Protecting settings from unauthorized access

The following options exist for protecting the configuration of the measuring device from unintentional modification after commissioning:



- Write protection via access code for the local display and Web browser
- Write protection via write protection switch
- Write protection via keypad lock

10.7.1 Write protection via access code



The effects of the user-specific access code are as follows:

- Via local operation, the parameters for the measuring device configuration are write-protected and their values can no longer be changed.
- Device access is protected via the Web browser, as are the parameters for the measuring device configuration.

Defining the access code via local display

1. Navigate to the **Define access code** parameter (→  110).
2. Define a max. 16-digit character string comprising numbers, letters and special characters as the access code.
3. Enter the access code again in the to confirm the code.
 - ↳ The -symbol appears in front of all write-protected parameters.

The device automatically locks the write-protected parameters again if a key is not pressed for 10 minutes in the navigation and editing view. The device locks the write-protected parameters automatically after 60 s if the user skips back to the operational display mode from the navigation and editing view.

-  If parameter write protection is activated via an access code, it can also only be deactivated via this access code →  65.
- The user role with which the user is currently logged on via the local display →  65 is indicated by the **Access status display** parameter. Navigation path: Operation → Access status display

Parameters which can always be modified via the local display

Certain parameters that do not affect the measurement are excepted from parameter write protection via the local display. Despite the user-specific access code, they can always be modified, even if the other parameters are locked.

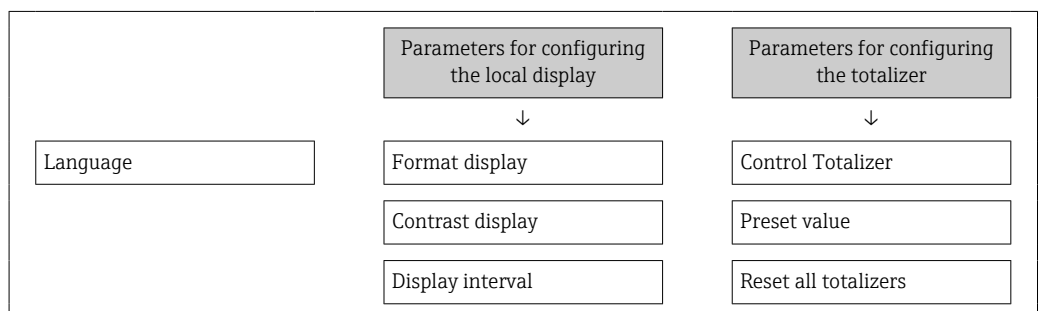

Defining the access code via the Web browser

1. Navigate to the **Define access code** parameter (→  110).
2. Define a max. 16-digit numeric code as an access code.

3. Enter the access code again in the to confirm the code.
 - ↳ The Web browser switches to the login page.

i If no action is performed for 10 minutes, the Web browser automatically returns to the login page.

- i**
- If parameter write protection is activated via an access code, it can also only be deactivated via this access code → 65.
 - The user role with which the user is currently logged on via Web browser is indicated by the **Access status tooling** parameter. Navigation path: Operation → Access status tooling

10.7.2 Write protection via write protection switch

Unlike parameter write protection via a user-specific access code, this allows the user to lock write access to the entire operating menu - apart from the **"Contrast display" parameter**.

The parameter values are now read only and cannot be edited any more (exception **"Contrast display" parameter**):

- Via local display
- Via service interface (CDI-RJ45)
- Via HART protocol

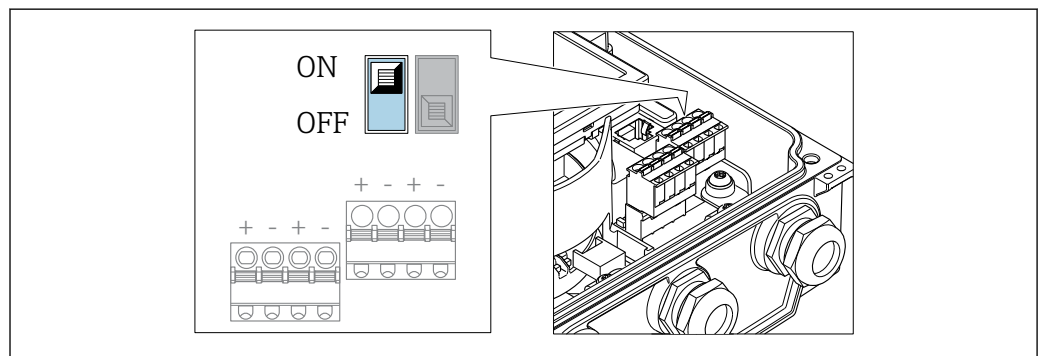

A0032092

1. Loosen the 4 fixing screws on the housing cover and open the housing cover.
2. Setting the write protection switch (WP) on the main electronics module to the **ON** position enables the hardware write protection. Setting the write protection switch (WP) on the main electronics module to the **OFF** position (factory setting) disables the hardware write protection.
 - ↳ If the hardware write protection is enabled: The **Hardware locked** option is displayed in the **Locking status** parameter . In addition, on the local display the  symbol appears in front of the parameters in the header of the operational display and in the navigation view.

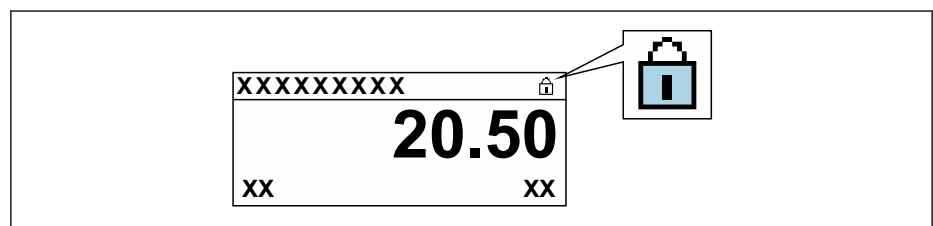

A0029425

If hardware write protection is disabled: No option is displayed in the **Locking status** parameter . On the local display, the  symbol disappears from in front of the parameters in the header of the operational display and in the navigation view.

3. ⚠ WARNING**Excessive tightening torque applied to the fixing screws!**

Risk of damaging the plastic transmitter.

- ▶ Tighten the fixing screws as per the tightening torque .

Reverse the removal procedure to reassemble the transmitter.



11 Operation

11.1 Reading the device locking status

Device active write protection: **Locking status** parameter



Operation → Locking status

Function scope of the "Locking status" parameter

Options	Description
None	The access status displayed in the Access status display parameter applies →  65. Only appears on local display.
Hardware locked	The DIP switch for hardware locking is activated on the main electronics module. This locks write access to the parameters (e.g. via local display or operating tool) →  114.
Temporarily locked	Write access to the parameters is temporarily locked on account of internal processes running in the device (e.g. data upload/download, reset etc.). Once the internal processing has been completed, the parameters can be changed once again.



11.2 Adjusting the operating language

 Detailed information:

- To configure the operating language →  81
- For information on the operating languages supported by the measuring device →  160

11.3 Configuring the display

Detailed information:





- On the basic settings for the local display →  97
- On the advanced settings for the local display →  104

11.4 Reading off measured values

With the **Measured values** submenu, it is possible to read all the measured values.

Navigation

"Diagnostics" menu → Measured values

▶ Measured values	
▶ Process variables	→  117
▶ System values	→  117
▶ Input values	→  118
▶ Output values	→  119
▶ Totalizer	→  120

11.4.1 Process variables

The **Process variables** submenu contains all the parameters needed to display the current measured values for each process variable.

Navigation

"Diagnostics" menu → Measured values → Process variables

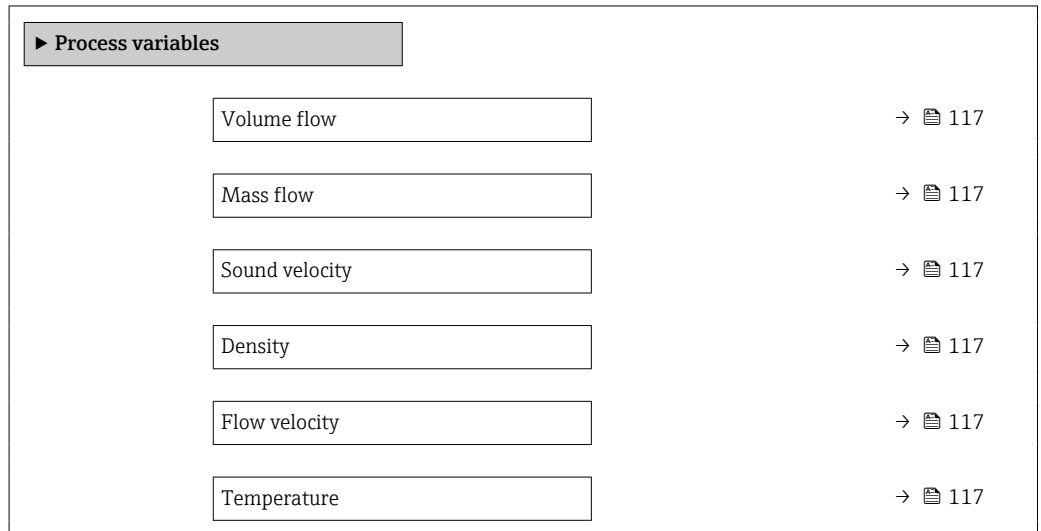

Parameter overview with brief description

Parameter	Description	User interface
Volume flow	Displays the volume flow that is currently measured. <i>Dependency</i> The unit is taken from: Volume flow unit parameter (→ 84)	Signed floating-point number
Mass flow	Displays the mass flow that is currently calculated. <i>Dependency</i> The unit is taken from the Mass flow unit parameter (→ 84).	Signed floating-point number
Sound velocity	Displays the sound velocity that is currently measured. <i>Dependency</i> The unit is taken from the Velocity unit parameter.	Signed floating-point number
Density	Displays the density that is currently calculated. <i>Dependency</i> The unit is taken from the Density unit parameter.	Signed floating-point number
Flow velocity	Displays the average flow velocity that is currently calculated. <i>Dependency</i> The unit is taken from the Velocity unit parameter.	Signed floating-point number
Temperature	Displays the temperature that is currently measured. <i>Dependency</i> The unit is taken from the Temperature unit parameter.	Signed floating-point number

11.4.2 System values

The **System values** submenu contains all the parameters needed to display the current measured values for every system value.

Navigation

"Diagnostics" menu → Measured values → System values

▶ System values

Signal strength	→ 118
Acceptance rate	→ 118
Signal to noise ratio	→ 118
Turbulence	→ 118

Parameter overview with brief description

Parameter	Description	User interface
Signal strength	Displays the current signal strength (0 to 100 dB). Assessment of the signal strength: <ul style="list-style-type: none"> ■ < 10 dB: bad ■ > 90 dB: very good 	Signed floating-point number
Acceptance rate	Displays the ratio of the number of ultrasonic signals accepted for flow calculation and the total number of ultrasonic signals emitted.	0 to 100 %
Signal to noise ratio	Displays the current signal to noise ratio (0 to 100 dB). Assessment of the signal to noise ratio: <ul style="list-style-type: none"> ■ < 20 dB: bad ■ > 50 dB: very good 	Signed floating-point number
Turbulence	Displays the current turbulence.	Signed floating-point number

11.4.3 Input values

The **Input values** submenu guides you systematically to the individual input values.

The submenu appears only if the device was ordered with a status input → 45.

Navigation

"Diagnostics" menu → Measured values → Input values

▶ Input values

Value status input	→ 119
--------------------	--------

Parameter overview with brief description

Parameter	Prerequisite	Description	User interface
Value status input	For the following order code: <ul style="list-style-type: none"> ▪ "Output; input", option I "4-20mA HART, 2x pul./freq./switch output; status input" ▪ "Output; input", option J "4-20mA HART, certified pulse output, switch output; status input" 	Shows the current input signal level.	<ul style="list-style-type: none"> ▪ High ▪ Low

11.4.4 Output values

The **Output values** submenu contains all the parameters needed to display the current measured values for every output.

-  The parameters displayed depend on:
- The selected device order
 - The set operating mode of the pulse/frequency/switch outputs

Navigation

"Diagnostics" menu → Measured values → Output values

► Output values	
Output current 1	→ ⓘ 119
Measured current 1	→ ⓘ 119
Pulse output 1	→ ⓘ 119
Output frequency 1	→ ⓘ 120
Switch state 1	→ ⓘ 120
Output frequency 2	→ ⓘ 120
Pulse output 2	→ ⓘ 119
Switch state 2	→ ⓘ 120

Parameter overview with brief description

Parameter	Prerequisite	Description	User interface
Output current	–	Displays the current value currently calculated for the current output.	3.59 to 22.5 mA
Measured current	–	Displays the current value currently measured for the current output.	0 to 30 mA
Pulse output 1 to n	The Pulse option is selected in the Operating mode parameter parameter.	Displays the pulse frequency currently output.	Positive floating-point number

Parameter	Prerequisite	Description	User interface
Output frequency 1 to n	In the Operating mode parameter, the Frequency option is selected.	Displays the value currently measured for the frequency output.	0.0 to 12 500.0 Hz
Switch state 1 to n	In the Operating mode parameter, the Switch option is selected.	Displays the current switch output status.	<ul style="list-style-type: none"> ▪ Open ▪ Closed

11.4.5 "Totalizer" submenu

The **Totalizer** submenu contains all the parameters needed to display the current measured values for every totalizer.

Navigation

"Diagnostics" menu → Measured values → Totalizer

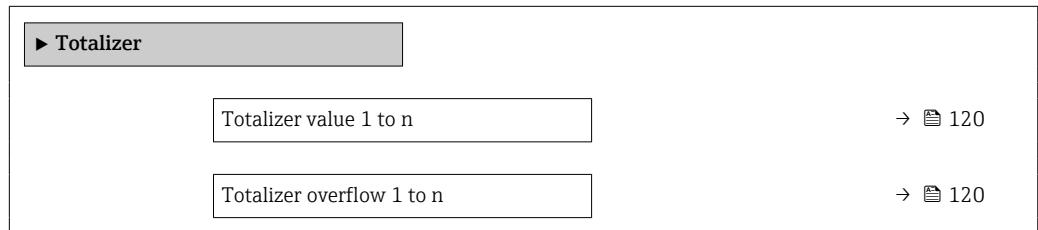

Parameter overview with brief description

Parameter	Prerequisite	Description	User interface
Totalizer value 1 to n	One of the following options is selected in the Assign process variable parameter (→ 103) of the Totalizer 1 to n submenu: <ul style="list-style-type: none"> ▪ Volume flow ▪ Mass flow 	Displays the current totalizer counter reading.	Signed floating-point number
Totalizer overflow 1 to n	One of the following options is selected in the Assign process variable parameter (→ 103) of the Totalizer 1 to n submenu: <ul style="list-style-type: none"> ▪ Volume flow ▪ Mass flow 	Displays the current totalizer overflow.	Integer with sign

11.5 Adapting the measuring device to the process conditions

The following are available for this purpose:

- Basic settings using the **Setup** menu (→ 81)
- Advanced settings using the **Advanced setup** submenu (→ 101)

11.6 Performing a totalizer reset

The totalizers are reset in the **Operation** submenu:

- Control Totalizer
- Reset all totalizers

Navigation

"Operation" menu → Totalizer handling

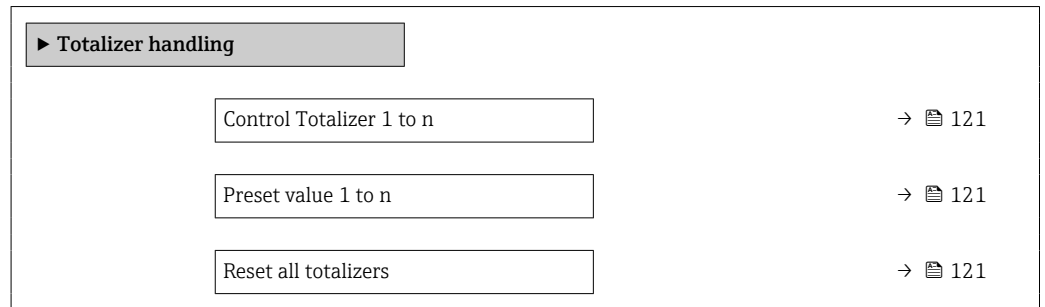

Parameter overview with brief description

Parameter	Prerequisite	Description	Selection / User entry	Factory setting
Control Totalizer 1 to n	A process variable is selected in the Assign process variable parameter (→ 103) of the Totalizer 1 to n submenu.	Control totalizer value.	<ul style="list-style-type: none"> ■ Totalize ■ Reset + hold ■ Preset + hold ■ Reset + totalize ■ Preset + totalize ■ Hold 	-
Preset value 1 to n	A process variable is selected in the Assign process variable parameter (→ 103) of the Totalizer 1 to n submenu.	Specify start value for totalizer. <i>Dependency</i> The unit of the selected process variable is specified for the totalizer in the Unit totalizer parameter (→ 103).	Signed floating-point number	Country-specific: <ul style="list-style-type: none"> ■ 0 m³ ■ 0 ft³
Reset all totalizers	-	Reset all totalizers to 0 and start.	<ul style="list-style-type: none"> ■ Cancel ■ Reset + totalize 	-

11.6.1 Function scope of the "Control Totalizer" parameter



Options	Description
Totalize	The totalizer is started or continues running.
Reset + hold	The totaling process is stopped and the totalizer is reset to 0.
Preset + hold	The totaling process is stopped and the totalizer is set to its defined start value from the Preset value parameter.
Reset + totalize	The totalizer is reset to 0 and the totaling process is restarted.
Preset + totalize	The totalizer is set to the defined start value from the Preset value parameter and the totaling process is restarted.

11.6.2 Function scope of the "Reset all totalizers" parameter

Options	Description
Cancel	No action is executed and the user exits the parameter.
Reset + totalize	Resets all totalizers to 0 and restarts the totaling process. This deletes all the flow values previously totalized.

11.7 Show data logging

The **Extended HistoROM** application package must be enabled in the device (order option) for the **Data logging** submenu to appear. This contains all the parameters for the measured value history.

-  Data logging is also available via:
 - Plant Asset Management Tool FieldCare →  74.
 - Web browser

Function scope

- A total of 1000 measured values can be stored
- 4 logging channels
- Adjustable logging interval for data logging
- Display of the measured value trend for each logging channel in the form of a chart

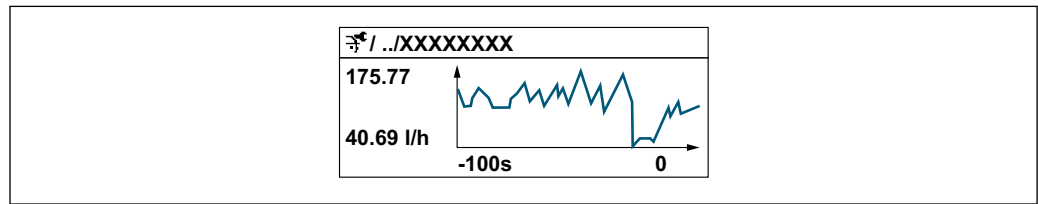

A0034352









- x-axis: depending on the number of channels selected displays 250 to 1000 measured values of a process variable.
- y-axis: displays the approximate measured value span and constantly adapts this to the ongoing measurement.

-  If the length of the logging interval or the assignment of the process variables to the channels is changed, the content of the data logging is deleted.

Navigation







"Diagnostics" menu → Data logging

▶ Data logging

Assign channel 1	→  123
Assign channel 2	→  123
Assign channel 3	→  123
Assign channel 4	→  123
Logging interval	→  123
Clear logging data	→  123
Data logging	→  123
Logging delay	→  123
Data logging control	→  123

Data logging status	→  124
Entire logging duration	→  124

Parameter overview with brief description

Parameter	Prerequisite	Description	Selection / User entry / User interface
Assign channel 1	The Extended HistoROM application package is available.	Assign process variable to logging channel.	<ul style="list-style-type: none"> ■ Off ■ Volume flow ■ Mass flow ■ Sound velocity ■ Flow velocity ■ Signal strength * ■ Signal to noise ratio * ■ Turbulence * ■ Acceptance rate * ■ Temperature * ■ Density * ■ Electronics temperature ■ Current output 1
Assign channel 2	The Extended HistoROM application package is available.  The software options currently enabled are displayed in the Software option overview parameter.	Assign process variable to logging channel.	For the picklist, see the Assign channel 1 parameter (→  123)
Assign channel 3	The Extended HistoROM application package is available.  The software options currently enabled are displayed in the Software option overview parameter.	Assign process variable to logging channel.	For the picklist, see the Assign channel 1 parameter (→  123)
Assign channel 4	The Extended HistoROM application package is available.  The software options currently enabled are displayed in the Software option overview parameter.	Assign process variable to logging channel.	For the picklist, see the Assign channel 1 parameter (→  123)
Logging interval	The Extended HistoROM application package is available.	Define the logging interval for data logging. This value defines the time interval between the individual data points in the memory.	0.1 to 3 600.0 s
Clear logging data	The Extended HistoROM application package is available.	Clear the entire logging data.	<ul style="list-style-type: none"> ■ Cancel ■ Clear data
Data logging	–	Select the data logging method.	<ul style="list-style-type: none"> ■ Overwriting ■ Not overwriting
Logging delay	In the Data logging parameter, the Not overwriting option is selected.	Enter the time delay for measured value logging.	0 to 999 h
Data logging control	In the Data logging parameter, the Not overwriting option is selected.	Start and stop measured value logging.	<ul style="list-style-type: none"> ■ None ■ Delete + start ■ Stop

Parameter	Prerequisite	Description	Selection / User entry / User interface
Data logging status	In the Data logging parameter, the Not overwriting option is selected.	Displays the measured value logging status.	<ul style="list-style-type: none">■ Done■ Delay active■ Active■ Stopped
Entire logging duration	In the Data logging parameter, the Not overwriting option is selected.	Displays the total logging duration.	Positive floating-point number

* Visibility depends on order options or device settings

12 Diagnostics and troubleshooting

12.1 General troubleshooting

For local display

Error	Possible causes	Remedy
Local display dark and no output signals	Supply voltage does not match that specified on the nameplate.	Apply the correct supply voltage → 48.
Local display dark and no output signals	No contact between connecting cables and terminals.	Check the connection of the cables and correct if necessary.
Local display dark and no output signals	Terminals are not plugged into the main electronics module correctly.	Check terminals.
Local display dark and no output signals	Main electronics module is defective.	Order spare part → 145.
Local display dark and no output signals	The connector between the main electronics module and display module is not plugged in correctly.	Check the connection and correct if necessary.
Local display dark and no output signals	The connecting cable is not plugged in correctly.	<ol style="list-style-type: none"> 1. Check the connection of the electrode cable and correct if necessary. 2. Check the connection of the coil current cable and correct if necessary.
Local display is dark, but signal output is within the valid range	Display is set too bright or too dark.	<ul style="list-style-type: none"> ▪ Set the display brighter by simultaneously pressing \oplus + \square. ▪ Set the display darker by simultaneously pressing \ominus + \square.
Local display is dark, but signal output is within the valid range	Display module is defective.	Order spare part → 145.
Backlighting of local display is red	Diagnostic event with "Alarm" diagnostic behavior has occurred.	Take remedial measures → 134
Text on local display appears in a foreign language and cannot be understood.	Incorrect operating language is configured.	<ol style="list-style-type: none"> 1. Press 2 s \square + \oplus ("home position"). 2. Press \square. 3. Set the desired language in the Display language parameter (→ 106).
Message on local display: "Communication Error" "Check Electronics"	Communication between the display module and the electronics is interrupted.	<ul style="list-style-type: none"> ▪ Check the cable and the connector between the main electronics module and display module. ▪ Order spare part → 145.

For output signals

Error	Possible causes	Remedial action
Signal output outside the valid range	Main electronics module is defective.	Order spare part → 145.
Device shows correct value on local display, but signal output is incorrect, though in the valid range.	Parametrization errors	Check parameterization and correct it.
Device measures incorrectly.	Configuration error or device is operated outside the application.	<ol style="list-style-type: none"> 1. Check and correct parameter configuration. 2. Observe limit values specified in the "Technical Data".

For access

Error	Possible causes	Remedial action
No write access to parameters	Hardware write protection enabled	Set the write protection switch on main electronics module to the OFF position → 114.
No write access to parameters	Current user role has limited access authorization	1. Check user role → 65. 2. Enter correct customer-specific access code → 65.
No connection via HART protocol	Communication resistor missing or incorrectly installed.	Install the communication resistor (250 Ω) correctly. Observe the maximum load → 151.
No connection via HART protocol	Commbobox <ul style="list-style-type: none"> ▪ Connected incorrectly ▪ Configured incorrectly ▪ Drivers not installed correctly ▪ USB interface on computer configured incorrectly 	Observe the documentation for the Commbobox.  FXA195 HART: Document "Technical Information" TI00404F
No connection to Web server	Web server disabled	Via the "FieldCare" or "DeviceCare" operating tool, check whether the Web server of the measuring device is enabled and enable it if necessary → 71.
	Incorrect settings for the Ethernet interface of the computer	1. Check the properties of the Internet protocol (TCP/IP) → 67 → 67. 2. Check the network settings with the IT manager.
No connection to Web server	Incorrect IP address	Check the IP address: 192.168.1.212 → 67 → 67
No connection to Web server	Incorrect WLAN access data	<ul style="list-style-type: none"> ▪ Check WLAN network status. ▪ Log on to the device again using WLAN access data. ▪ Check that WLAN is enabled on the measuring device and operating device .
	WLAN communication disabled	–
Not connecting to Web server, FieldCare or DeviceCare	No WLAN network available	<ul style="list-style-type: none"> ▪ Check if WLAN reception is present: LED on display module is lit blue ▪ Check if WLAN connection is enabled: LED on display module flashes blue ▪ Switch on instrument function.
	WLAN network is weak.	Operating device is outside of reception range: Check network status on operating device.
Network connection not present or unstable	Parallel WLAN and Ethernet communication	<ul style="list-style-type: none"> ▪ Check network settings. ▪ Temporarily enable only the WLAN as an interface.
	WLAN network is weak.	Operating device is outside of reception range: Check network status on operating device.
Web browser frozen and operation no longer possible	Data transfer active	Wait until data transfer or current action is finished.
	Connection lost	1. Check cable connection and power supply. 2. Refresh the Web browser and restart if necessary.
Content of Web browser incomplete or difficult to read	Not using optimum version of Web server.	1. Use the correct Web browser version → 66. 2. Clear the Web browser cache and restart the Web browser.

Error	Possible causes	Remedial action
	Unsuitable view settings.	Change the font size/display ratio of the Web browser.
No or incomplete display of contents in the Web browser	<ul style="list-style-type: none"> ▪ JavaScript not enabled ▪ JavaScript cannot be enabled 	<ol style="list-style-type: none"> 1. Enable JavaScript. 2. Enter <code>http://192.168.1.212/basic.html</code> as the IP address.
Operation with FieldCare or DeviceCare via CDI-RJ45 service interface (port 8000)	Firewall of computer or network is preventing communication	Depending on the settings of the firewall used on the computer or in the network, the firewall must be adapted or disabled to allow FieldCare/DeviceCare access.
Flashing of firmware with FieldCare or DeviceCare via CDI-RJ45 service interface (via port 8000 or TFTP ports)	Firewall of computer or network is preventing communication	Depending on the settings of the firewall used on the computer or in the network, the firewall must be adapted or disabled to allow FieldCare/DeviceCare access.

12.2 Diagnostic information via light emitting diodes

12.2.1 Transmitter

Different LEDs in the transmitter provide information on the device status.

LED	Color	Meaning
Supply voltage	Off	Supply voltage is off or too low
	Green	Supply voltage is ok
Link/Activity	Orange	Link available but no activity
	Flashing orange	Activity present
Communication	Flashing white	HART communication is active.
Alarm	Green	Measuring device is ok
	Flashing green	Measuring device not configured
	Off	Firmware error
	Red	Main error
	Flashing red	Error
	Flashing red/green	Start measuring device

12.3 Diagnostic information on local display

12.3.1 Diagnostic message

Faults detected by the self-monitoring system of the measuring device are displayed as a diagnostic message in alternation with the operational display.

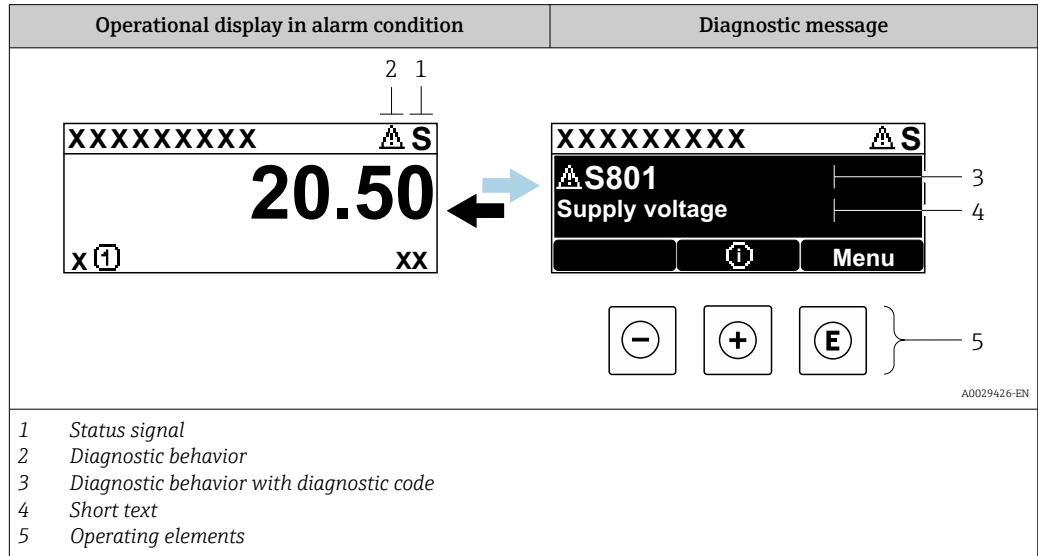

If two or more diagnostic events are pending simultaneously, only the message of the diagnostic event with the highest priority is shown.

- i** Other diagnostic events that have occurred can be displayed in the **Diagnostics** menu:
 - Via parameter → 137
 - Via submenus → 138



Status signals

The status signals provide information on the state and reliability of the device by categorizing the cause of the diagnostic information (diagnostic event).

- i** The status signals are categorized according to VDI/VDE 2650 and NAMUR Recommendation NE 107: F = Failure, C = Function Check, S = Out of Specification, M = Maintenance Required

Symbol	Meaning
F	Failure A device error has occurred. The measured value is no longer valid.
C	Function check The device is in service mode (e.g. during a simulation).
S	Out of specification The device is operated: <ul style="list-style-type: none"> ▪ Outside its technical specification limits (e.g. outside the process temperature range) ▪ Outside of the configuration carried out by the user (e.g. maximum flow in parameter 20 mA value)
M	Maintenance required Maintenance is required. The measured value remains valid.

Diagnostic behavior



Symbol	Meaning
	Alarm <ul style="list-style-type: none"> ▪ Measurement is interrupted. ▪ Signal outputs and totalizers assume the defined alarm condition. ▪ A diagnostic message is generated. ▪ The background lighting changes to red.
	Warning Measurement is resumed. The signal outputs and totalizers are not affected. A diagnostic message is generated.

Diagnostic information

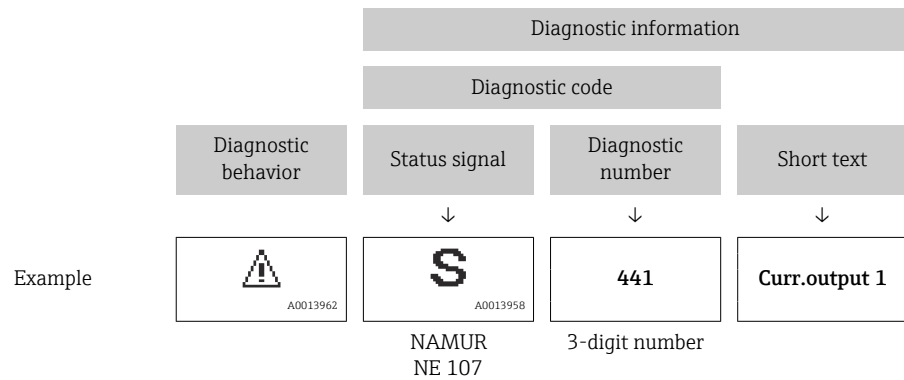
The fault can be identified using the diagnostic information. The short text helps you by providing information about the fault. In addition, the corresponding symbol for the diagnostic behavior is displayed in front of the diagnostic information on the local display.



Operating elements

Key	Meaning
	Plus key <i>In a menu, submenu</i> Opens the message about remedy information.
	Enter key <i>In a menu, submenu</i> Opens the operating menu.

12.3.2 Calling up remedial measures

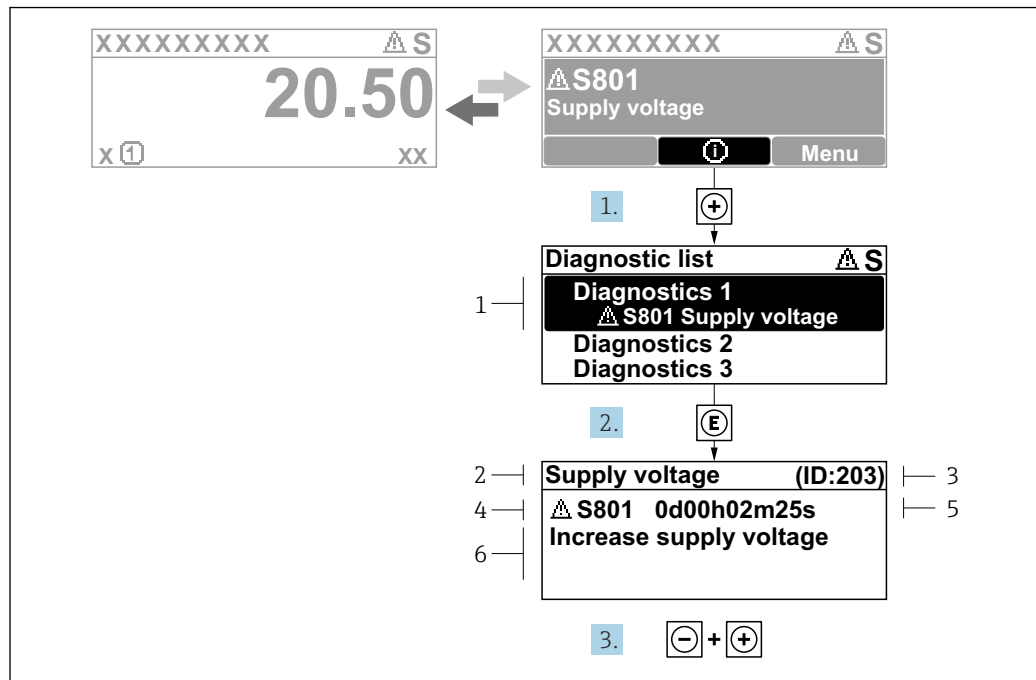

A0029431-EN

51 Message about remedial measures

- 1 Diagnostic information
- 2 Short text
- 3 Service ID
- 4 Diagnostic behavior with diagnostic code
- 5 Operation time of occurrence
- 6 Remedial measures

1. The user is in the diagnostic message.
Press \oplus (ⓘ symbol).
↳ The **Diagnostic list** submenu opens.
2. Select the desired diagnostic event with \oplus or \ominus and press \boxplus .
↳ The message about the remedial measures opens.
3. Press $\ominus + \oplus$ simultaneously.
↳ The message about the remedial measures closes.

The user is in the **Diagnostics** menu at an entry for a diagnostics event, e.g. in the **Diagnostic list** submenu or **Previous diagnostics** parameter.

1. Press \boxplus .
↳ The message for the remedial measures for the selected diagnostic event opens.
2. Press $\ominus + \oplus$ simultaneously.
↳ The message for the remedial measures closes.

12.4 Diagnostic information in the Web browser

12.4.1 Diagnostic options

Any faults detected by the measuring device are displayed in the Web browser on the home page once the user has logged on.

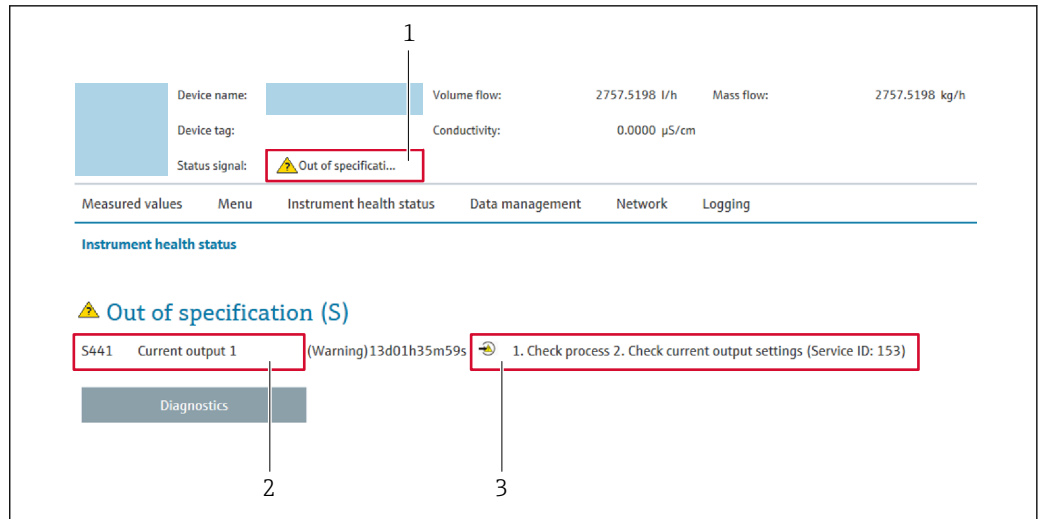

- 1 Status area with status signal
- 2 Diagnostics information → 129
- 3 Remedial measures with service ID

i In addition, diagnostic events which have occurred can be shown in the **Diagnostics** menu:

- Via parameter → 137
- Via submenu → 138

Status signals

The status signals provide information on the state and reliability of the device by categorizing the cause of the diagnostic information (diagnostic event).

Symbol	Meaning
	Failure A device error has occurred. The measured value is no longer valid.
	Function check The device is in service mode (e.g. during a simulation).
	Out of specification The device is operated: <ul style="list-style-type: none"> ▪ Outside its technical specification limits (e.g. outside the process temperature range) ▪ Outside of the configuration carried out by the user (e.g. maximum flow in parameter 20 mA value)
	Maintenance required Maintenance is required. The measured value is still valid.

i The status signals are categorized in accordance with VDI/VDE 2650 and NAMUR Recommendation NE 107.

12.4.2 Calling up remedy information

Remedy information is provided for every diagnostic event to ensure that problems can be rectified quickly. These measures are displayed in red along with the diagnostic event and the related diagnostic information.

12.5 Diagnostic information in FieldCare or DeviceCare

12.5.1 Diagnostic options

Any faults detected by the measuring device are displayed on the home page of the operating tool once the connection has been established.

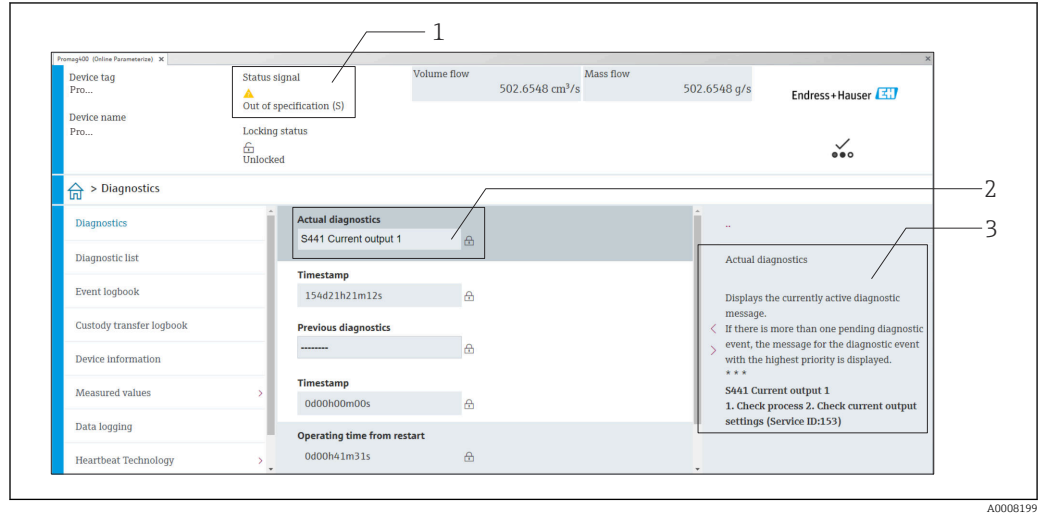

- 1 Status area with status signal → 128
- 2 Diagnostics information → 129
- 3 Remedial measures with service ID

i In addition, diagnostic events which have occurred can be shown in the **Diagnostics** menu:

- Via parameter → 137
- Via submenu → 138

Diagnostic information

The fault can be identified using the diagnostic information. The short text helps you by providing information about the fault. In addition, the corresponding symbol for the diagnostic behavior is displayed in front of the diagnostic information on the local display.

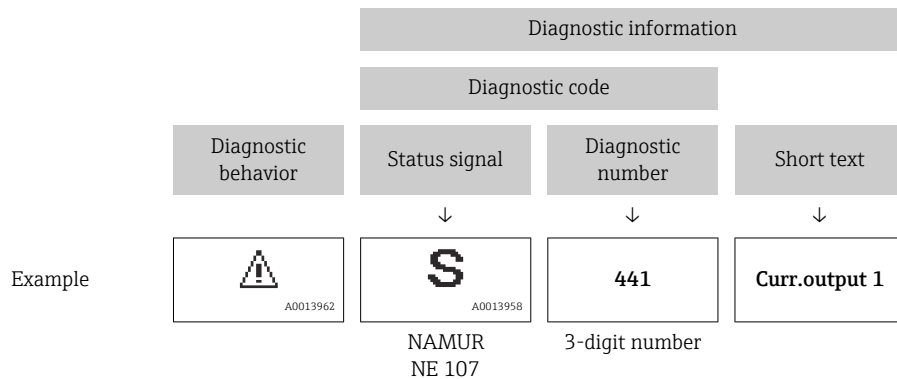

12.5.2 Calling up remedy information

Remedy information is provided for every diagnostic event to ensure that problems can be rectified quickly:

- On the home page
Remedy information is displayed in a separate field below the diagnostics information.
- In the **Diagnostics** menu
Remedy information can be called up in the working area of the user interface.

The user is in the **Diagnostics** menu.

1. Call up the desired parameter.
2. On the right in the working area, mouse over the parameter.
 - ↳ A tool tip with remedy information for the diagnostic event appears.

12.6 Adapting the diagnostic information

12.6.1 Adapting the diagnostic behavior

Each item of diagnostic information is assigned a specific diagnostic behavior at the factory. The user can change this assignment for specific diagnostic information in the **Diagnostic behavior** submenu.

Expert → System → Diagnostic handling → Diagnostic behavior

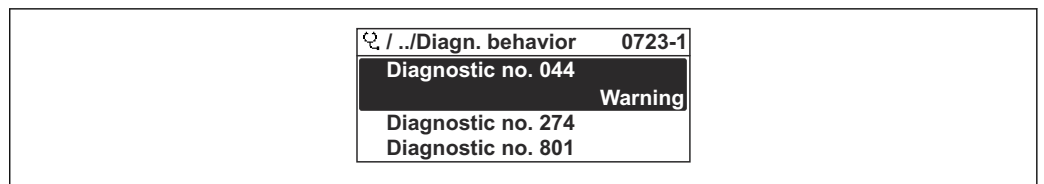

A0014048-EN

52 Taking the example of the local display

You can assign the following options to the diagnostic number as the diagnostic behavior:

Options	Description
Alarm	The device stops measurement. The signal outputs and totalizers assume the defined alarm condition. A diagnostic message is generated. The background lighting changes to red.
Warning	The device continues to measure. The signal outputs and totalizers are not affected. A diagnostic message is generated.
Logbook entry only	The device continues to measure. The diagnostic message is displayed only in the Event logbook submenu (Event list submenu) and is not displayed in alternation with the operational display.
Off	The diagnostic event is ignored, and no diagnostic message is generated or entered.

12.6.2 Adapting the status signal

Each item of diagnostic information is assigned a specific status signal at the factory. The user can change this assignment for specific diagnostic information in the **Diagnostic event category** submenu.

Expert → Communication → Diagnostic event category



Available status signals

Configuration as per HART 7 Specification (Condensed Status), in accordance with NAMUR NE107.

Symbol	Meaning
F A0013956	Failure A device error is present. The measured value is no longer valid.
C A0013959	Function check The device is in service mode (e.g. during a simulation).
S A0013958	Out of specification The device is being operated: <ul style="list-style-type: none"> ▪ Outside its technical specification limits (e.g. outside the process temperature range) ▪ Outside of the configuration carried out by the user (e.g. maximum flow in parameter 20 mA value)
M A0013957	Maintenance required Maintenance is required. The measured value is still valid.
N A0023076	Has no effect on the condensed status.

12.7 Overview of diagnostic information

 The amount of diagnostic information and the number of measured variables affected increase if the measuring device has one or more application packages.

 In the case of some items of diagnostic information, the status signal and the diagnostic behavior can be changed. Change the diagnostic information →  133

Diagnostic number	Short text	Remedy instructions	Status signal [from the factory]	Diagnostic behavior [from the factory]
Diagnostic of sensor				
019	Device initialization active	Device initialization in progress, please wait	S	Warning ¹⁾
082	Data storage	1. Check module connections 2. Change electronic modules	F	Alarm
083	Memory content	1. Restart device 2. Restore HistoROM S-DAT backup ('Device reset' parameter) 3. Replace HistoROM S-DAT	F	Alarm
104	Sensor signal path 1 to n	1. Check process conditions 2. Clean/repl. transd. (inline) / check sensor pos. and coupling (clamp on) 3. Replace sensor electronic module (ISEM)	F	Alarm
105	Downstream transducer path 1 to n defective	1. Check connection to the downstream transducer 2. Replace downstream transducer	F	Alarm
106	Upstream transducer path 1 to n defective	1. Check connection to the upstream transducer 2. Replace upstream transducer	F	Alarm
160	Signal path switched off	Contact service	M	Warning ¹⁾
Diagnostic of electronic				
201	Device failure	Restart device	F	Alarm

Diagnostic number	Short text	Remedy instructions	Status signal [from the factory]	Diagnostic behavior [from the factory]
242	Software incompatible	1. Check software 2. Flash or change main electronic module	F	Alarm
252	Modules incompatible	1. Check electronic modules 2. Check if correct modules are available (e.g. NEx, Ex) 3. Replace electronic modules	F	Alarm
252	Modules incompatible	1. Check if correct electronic module is plugged 2. Replace electronic module	F	Alarm
261	Electronic modules	1. Restart device 2. Check electronic modules 3. Change I/O module or main electronics	F	Alarm
262	Sensor electronics connection faulty	1. Check/replace connection cable between sensor electronic module (ISEM) and main electr. 2. Check/replace module cartridge, ISEM, main electr.	F	Alarm
270	Main electronics failure	Change main electronic module	F	Alarm
271	Main electronics failure	1. Restart device 2. Change main electronic module	F	Alarm
272	Main electronics failure	Restart device	F	Alarm
273	Main electronics failure	Change electronics	F	Alarm
275	I/O module defective	Change I/O module	F	Alarm
276	I/O module faulty	1. Restart device 2. Change I/O module	F	Alarm
281	Electronic initialization	Firmware update active, please wait!	F	Alarm
283	Memory content	Reset device	F	Alarm
283	Memory content	Restart device	F	Alarm
302	Device verification in progress	Device verification active, please wait.	C	Warning
311	Electronic failure	1. Do not reset device 2. Contact service	M	Warning
372	Sensor electronics (ISEM) faulty	1. Restart device 2. Check if failure recurs 3. Replace sensor electronic module (ISEM)	F	Alarm
373	Sensor electronics (ISEM) faulty	Transfer data or reset device	F	Alarm
375	I/O- communication failed	1. Restart device 2. Check if failure recurs 3. Replace module rack inclusive electronic modules	F	Alarm
378	Supply voltage ISEM faulty	Check supply voltage to the ISEM	F	Alarm
382	Data storage	1. Insert T-DAT 2. Replace T-DAT	F	Alarm
383	Memory content	1. Restart device 2. Delete T-DAT via 'Reset device' parameter 3. Replace T-DAT	F	Alarm

Diagnostic number	Short text	Remedy instructions	Status signal [from the factory]	Diagnostic behavior [from the factory]
384	Transmitter circuit	1. Restart device 2. Check if failure recurs 3. Replace sensor electronic module (ISEM)	F	Alarm
385	Amplifier circuit	1. Restart device 2. Check if failure recurs 3. Replace sensor electronic module (ISEM)	F	Alarm
386	Time of flight	1. Restart device 2. Check if failure recurs 3. Replace sensor electronic module (ISEM)	F	Alarm
387	HistoROM data faulty	Contact service organization	F	Alarm
Diagnostic of configuration				
410	Data transfer	1. Check connection 2. Retry data transfer	F	Alarm
412	Processing download	Download active, please wait	C	Warning
431	Trim 1	Carry out trim	C	Warning
437	Configuration incompatible	Restart device	F	Alarm
438	Dataset	1. Check data set file 2. Check device configuration 3. Up- and download new configuration	M	Warning
441	Current output	1. Check process 2. Check current output settings	S	Warning ¹⁾
442	Frequency output 1 to n	1. Check process 2. Check frequency output settings	S	Warning ¹⁾
443	Pulse output 1 to n	1. Check process 2. Check pulse output settings	S	Warning ¹⁾
453	Flow override	Deactivate flow override	C	Warning
484	Failure mode simulation	Deactivate simulation	C	Alarm
485	Measured variable simulation	Deactivate simulation	C	Warning
491	Current output 1 simulation	Deactivate simulation	C	Warning
492	Simulation frequency output 1 to n	Deactivate simulation frequency output	C	Warning
493	Pulse output 1 to n simulation active	Deactivate pulse output simulation	C	Warning
494	Switch output simulation 1 to n	Deactivate simulation switch output	C	Warning
495	Diagnostic event simulation	Deactivate simulation	C	Warning
496	Status input simulation	Deactivate simulation status input	C	Warning
537	Configuration	1. Check IP addresses in network 2. Change IP address	F	Warning
Diagnostic of process				
803	Current loop	1. Check wiring 2. Change I/O module	F	Alarm





Diagnostic number	Short text	Remedy instructions	Status signal [from the factory]	Diagnostic behavior [from the factory]
832	Electronics temperature too high	Reduce ambient temperature	S	Warning ¹⁾
833	Electronics temperature too low	Increase ambient temperature	S	Warning ¹⁾
840	Sensor range	Check flow velocity	S	Warning ¹⁾
842	Process limit	Low flow cut off active! 1. Check low flow cut off configuration	S	Warning ¹⁾
870	Measuring inaccuracy increased	1. Check process conditions 2. Increase flow velocity	S	Warning ¹⁾
881	Sensor signal path 1 to n	1. Check process conditions 2. Clean/repl. transd. (inline) / check sensor pos. and coupling (clamp on) 3. Replace sensor electronic module (ISEM)	F	Alarm
882	Input signal	1. Check input configuration 2. Check external device or process conditions	F	Alarm
930	Sound velocity too high	1. Check process conditions 2. Clean/repl. transd. (inline) / check sensor pos. and coupling (clamp on) 3. Replace sensor electronic module (ISEM)	S	Warning ¹⁾
931	Sound velocity too low	1. Check process conditions 2. Clean/repl. transd. (inline) / check sensor pos. and coupling (clamp on) 3. Replace sensor electronic module (ISEM)	S	Warning ¹⁾
953	Asymmetry noise signal too high path 1 to n	1. Check process conditions 2. Clean/repl. transd. (inline) / check sensor pos. and coupling (clamp on) 3. Replace sensor electronic module (ISEM)	F	Alarm



1) Diagnostic behavior can be changed.

12.8 Pending diagnostic events

The **Diagnostics** menu allows the user to view the current diagnostic event and the previous diagnostic event separately.





 To call up the measures to rectify a diagnostic event:

- Via local display →  130
- Via web browser →  131
- Via "FieldCare" operating tool →  133
- Via "DeviceCare" operating tool →  133

 Other pending diagnostic events can be displayed in the **Diagnostic list** submenu →  138

Navigation

"Diagnostics" menu

 Diagnostics	
Actual diagnostics	→  138
Previous diagnostics	→  138
Operating time from restart	→  138
Operating time	→  138

Parameter overview with brief description

Parameter	Prerequisite	Description	User interface
Actual diagnostics	A diagnostic event has occurred.	Shows the current occurred diagnostic event along with its diagnostic information.  If two or more messages occur simultaneously, the message with the highest priority is shown on the display.	Symbol for diagnostic behavior, diagnostic code and short message.
Previous diagnostics	Two diagnostic events have already occurred.	Shows the diagnostic event that occurred prior to the current diagnostic event along with its diagnostic information.	Symbol for diagnostic behavior, diagnostic code and short message.
Operating time from restart	–	Shows the time the device has been in operation since the last device restart.	Days (d), hours (h), minutes (m) and seconds (s)
Operating time	–	Indicates how long the device has been in operation.	Days (d), hours (h), minutes (m) and seconds (s)

12.9 Diagnostic list

Up to 5 currently pending diagnostic events can be displayed in the **Diagnostic list** submenu along with the associated diagnostic information. If more than 5 diagnostic events are pending, the events with the highest priority are shown on the display.

Navigation path

Diagnostics → Diagnostic list

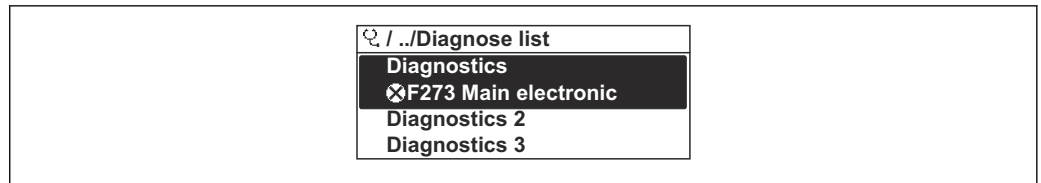

A0014006-EN

53 Taking the example of the local display

- i** To call up the measures to rectify a diagnostic event:
- Via local display → 130
 - Via web browser → 131
 - Via "FieldCare" operating tool → 133
 - Via "DeviceCare" operating tool → 133

12.10 Event logbook

12.10.1 Reading out the event logbook

A chronological overview of the event messages that have occurred is provided in the **Events list** submenu.

Navigation path

Diagnostics menu → **Event logbook** submenu → Event list

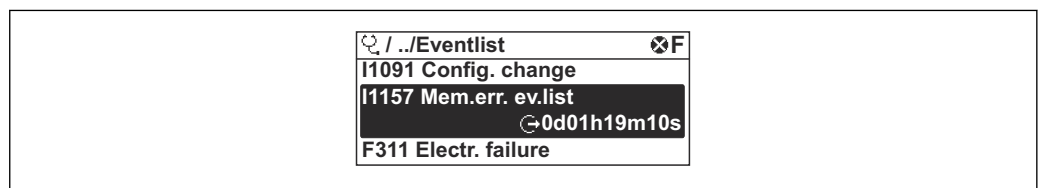

A0014008-EN

54 Taking the example of the local display

- A maximum of 20 event messages can be displayed in chronological order.
- If the **Extended HistoROM** application package (order option) is enabled in the device, the event list can contain up to 100 entries .

The event history includes entries for:

- Diagnostic events → 134
- Information events → 140

In addition to the operation time of its occurrence, each event is also assigned a symbol that indicates whether the event has occurred or is ended:

- Diagnostic event
 - ⌚: Occurrence of the event
 - ⌚: End of the event
- Information event
 - ⌚: Occurrence of the event

- i** To call up the measures to rectify a diagnostic event:
- Via local display → 130
 - Via web browser → 131
 - Via "FieldCare" operating tool → 133
 - Via "DeviceCare" operating tool → 133

- i** For filtering the displayed event messages → 140

12.10.2 Filtering the event logbook

Using the **Filter options** parameter you can define which category of event message is displayed in the **Events list** submenu.

Navigation path

Diagnostics → Event logbook → Filter options

Filter categories

- All
- Failure (F)
- Function check (C)
- Out of specification (S)
- Maintenance required (M)
- Information (I)

12.10.3 Overview of information events

Unlike a diagnostic event, an information event is displayed in the event logbook only and not in the diagnostic list.

Info number	Info name
I1000	----- (Device ok)
I1079	Sensor changed
I1089	Power on
I1090	Configuration reset
I1091	Configuration changed
I1092	HistoROM backup deleted
I1137	Electronics changed
I1151	History reset
I1155	Reset electronics temperature
I1156	Memory error trend
I1157	Memory error event list
I1256	Display: access status changed
I1278	I/O module restarted
I1327	Zero point adjust failed signal path
I1335	Firmware changed
I1361	Web server: login failed
I1397	Fieldbus: access status changed
I1398	CDI: access status changed
I1444	Device verification passed
I1445	Device verification failed
I1457	Measurement error verification failed
I1459	I/O module verification failed
I1461	Sensor verification failed
I1462	Sensor electronic module verific. failed
I1512	Download started
I1513	Download finished
I1514	Upload started
I1515	Upload finished

Info number	Info name
I1622	Calibration changed
I1624	All totalizers reset
I1625	Write protection activated
I1626	Write protection deactivated
I1627	Web server: login successful
I1628	Display: login successful
I1629	CDI: login successful
I1631	Web server access changed
I1632	Display: login failed
I1633	CDI: login failed
I1634	Reset to factory settings
I1635	Reset to delivery settings
I1649	Hardware write protection activated
I1650	Hardware write protection deactivated
I1725	Sensor electronic module (ISEM) changed

12.11 Resetting the measuring device

Using the **Device reset** parameter (→ ⓘ 110) it is possible to reset the entire device configuration or some of the configuration to a defined state.

12.11.1 Function scope of the "Device reset" parameter

Options	Description
Cancel	No action is executed and the user exits the parameter.
To delivery settings	Every parameter for which a customer-specific default setting was ordered is reset to this customer-specific value. All other parameters are reset to the factory setting.
Restart device	The restart resets every parameter whose data are in the volatile memory (RAM) to the factory setting (e.g. measured value data). The device configuration remains unchanged.









12.12 Device information

The **Device information** submenu contains all parameters that display different information for device identification.





Navigation

"Diagnostics" menu → Device information

▶ Device information	
Device tag	→ ⓘ 142
Serial number	→ ⓘ 142

Firmware version	→  142
Order code	→  142
Extended order code 1	→  142
Extended order code 2	→  142
Extended order code 3	→  143
ENP version	→  143
Device revision	→  143
Device ID	→  143
Device type	→  143
Manufacturer ID	→  143



Parameter overview with brief description

Parameter	Description	User interface	Factory setting
Device tag	Shows name of measuring point.	Max. 32 characters, such as letters, numbers or special characters (e.g. @, %, /).	–
Serial number	Shows the serial number of the measuring device.	Max. 11-digit character string comprising letters and numbers.	–
Firmware version	Shows the device firmware version installed.	Character string in the format xx.yy.zz	–
Device name	Shows the name of the transmitter.  The name can be found on the nameplate of the transmitter.	Max. 32 characters such as letters or numbers.	–
Order code	Shows the device order code.  The order code can be found on the nameplate of the sensor and transmitter in the "Order code" field.	Character string composed of letters, numbers and certain punctuation marks (e.g. /).	–
Extended order code 1	Shows the 1st part of the extended order code.  The extended order code can also be found on the nameplate of the sensor and transmitter in the "Ext. ord. cd." field.	Character string	–
Extended order code 2	Shows the 2nd part of the extended order code.  The extended order code can also be found on the nameplate of the sensor and transmitter in the "Ext. ord. cd." field.	Character string	–

Parameter	Description	User interface	Factory setting
Extended order code 3	Shows the 3rd part of the extended order code.  The extended order code can also be found on the nameplate of the sensor and transmitter in the "Ext. ord. cd." field.	Character string	–
ENP version	Shows the version of the electronic nameplate (ENP).	Character string	–
Device revision	Shows the device revision with which the device is registered with the HART Communication Foundation.	2-digit hexadecimal number	–
Device ID	Shows the device ID for identifying the device in a HART network.	6-digit hexadecimal number	–
Device type	Shows the device type with which the measuring device is registered with the HART Communication Foundation.	2-digit hexadecimal number	0x69 (for Prosonic Flow W 400)
Manufacturer ID	Shows the device's manufacturer ID registered with the HART Communication Foundation.	2-digit hexadecimal number	0x11 (for Endress+Hauser)

12.13 Firmware history

Release date	Firmware version	Order code for "Firmware version"	Firmware changes	Documentation type	Documentation
12.2021	01.00.00	Option 78	Original firmware	Operating Instructions	BA02086D/06

-  It is possible to flash the firmware to the current version or the previous version using the service interface.
-  For the compatibility of the firmware version with the previous version, the installed device description files and operating tools, observe the information about the device in the "Manufacturer's information" document.
-  The manufacturer's information is available:
 - In the Download Area of the Endress+Hauser web site: www.endress.com → Downloads
 - Specify the following details:
 - Product root: e.g. 9W4B
The product root is the first part of the order code: see the nameplate on the device.
 - Text search: Manufacturer's information
 - Media type: Documentation – Technical Documentation

13 Maintenance

13.1 Maintenance tasks

No special maintenance work is required.

13.1.1 Exterior cleaning

When cleaning the exterior of measuring devices, always use cleaning agents that do not attack the surface of the housing or the seals.

13.2 Measuring and test equipment

Endress+Hauser offers a wide variety of measuring and test equipment, such as W@M or device tests.

 Your Endress+Hauser Sales Center can provide detailed information on the services.

List of some of the measuring and testing equipment: →  149 →  147

13.3 Endress+Hauser services

Endress+Hauser offers a wide variety of services for maintenance such as recalibration, maintenance service or device tests.

 Your Endress+Hauser Sales Center can provide detailed information on the services.

14 Repair

14.1 General information

14.1.1 Repair and conversion concept

The Endress+Hauser repair and conversion concept provides for the following:

- The measuring devices have a modular design.
- Spare parts are grouped into logical kits with the associated Installation Instructions.
- Repairs are carried out by Endress+Hauser Service or by appropriately trained customers.
- Certified devices can only be converted to other certified devices by Endress+Hauser Service or at the factory.

14.1.2 Notes for repair and conversion



For repair and modification of a measuring device, observe the following notes:

- ▶ Use only original Endress+Hauser spare parts.
- ▶ Carry out the repair according to the Installation Instructions.
- ▶ Observe the applicable standards, federal/national regulations, Ex documentation (XA) and certificates.
- ▶ Document every repair and each conversion and enter them into the *W@M* life cycle management database and Netilion Analytics.

14.2 Spare parts

W@M Device Viewer (www.endress.com/deviceviewer):

All the spare parts for the measuring device, along with the order code, are listed here and can be ordered. If available, users can also download the associated Installation Instructions.

-  Measuring device serial number:
 - Is located on the nameplate of the device.
 - Can be read out via the **Serial number** parameter (→  142) in the **Device information** submenu.

14.3 Endress+Hauser services

Endress+Hauser offers a wide range of services.

-  Your Endress+Hauser Sales Center can provide detailed information on the services.

14.4 Return

The requirements for safe device return can vary depending on the device type and national legislation.

1. Refer to the website for more information:
<http://www.endress.com/support/return-material>
2. Return the device if repairs or a factory calibration are required, or if the wrong device was ordered or delivered.

14.5 Disposal



If required by the Directive 2012/19/EU on waste electrical and electronic equipment (WEEE), the product is marked with the depicted symbol in order to minimize the disposal of WEEE as unsorted municipal waste. Do not dispose of products bearing this marking as unsorted municipal waste. Instead, return them to Endress+Hauser for disposal under the applicable conditions.

14.5.1 Removing the measuring device

1. Switch off the device.

⚠ WARNING

Danger to persons from process conditions!

- ▶ Pay attention to high temperatures.
2. Carry out the mounting and connection steps from the "Mounting the measuring device" and "Connecting the measuring device" sections in reverse order. Observe the safety instructions.

14.5.2 Disposing of the measuring device

Observe the following notes during disposal:







- ▶ Observe valid federal/national regulations.
- ▶ Ensure proper separation and reuse of the device components.

15 Accessories

Various accessories, which can be ordered with the device or subsequently from Endress+Hauser, are available for the device. Detailed information on the order code in question is available from your local Endress+Hauser sales center or on the product page of the Endress+Hauser website: www.endress.com.

15.1 Device-specific accessories

15.1.1 For the transmitter







Accessories	Description
Transmitter Prosonic Flow 400	<p>Transmitter for replacement or storage. Use the order code to define the following specifications:</p> <ul style="list-style-type: none"> ▪ Approvals ▪ Output / input ▪ Display/operation ▪ Housing ▪ Software <p> For details, see Installation Instructions EA00104D</p>
Post mounting kit	Post mounting kit for transmitter.
External WLAN antenna	<p>External WLAN antenna with 1.5 m (59.1 in) connecting cable and two angle brackets. Order code for "Accessory enclosed", option P8 "Wireless antenna wide area".</p> <ul style="list-style-type: none"> ▪  The external WLAN antenna is not suitable for use in hygienic applications. ▪ Additional information regarding the WLAN interface →  72. <p> Order number: 71351317</p> <p> Installation Instructions EA01238D</p>
Sensor cable Proline 400 Sensor – transmitter	<p>The sensor cable can be ordered directly with the measuring device (order code for "Cable") or as an accessory (order number DK9017).</p> <p>The following cable lengths are available:</p> <ul style="list-style-type: none"> ▪ Temperature: -40 to +80 °C (-40 to +176 °F) <ul style="list-style-type: none"> ▪ Option AA: 5 m (15 ft) ▪ Option AB: 10 m (30 ft) ▪ Option AC: 15 m (45 ft) ▪ Option AD: 30 m (90 ft) ▪ Temperature: -40 to +130 °C (-40 to +266 °F) <ul style="list-style-type: none"> ▪ Option FA: 5 m (15 ft) ▪ Option FB: 10 m (30 ft) ▪ Option FC: 15 m (45 ft) ▪ Option FD: 30 m (90 ft) <p> Possible cable length for a Proline 400 sensor cable: Max. 30 m (90 ft)</p>

15.1.2 For the sensor



Accessories	Description
Sensor set (DK9018)	<ul style="list-style-type: none"> ▪ Sensor set 0.3 MHz (C-030) ▪ Sensor set 0.5 MHz (C-050) ▪ Sensor set 1 MHz (C-100) ▪ Sensor set 2 MHz (C-200) ▪ Sensor set 5 MHz (C-500)
Sensor holder set (DK9014)	<ul style="list-style-type: none"> ▪ Sensor holder set 0.3 to 2 MHz ▪ Sensor holder set 5 MHz

Accessories	Description
Installation set (DK9015)	<ul style="list-style-type: none"> ■ Installation set, DN15-DN32, 1/2-1 1/4" ■ Installation set, DN32-DN65, 1 1/2-2 1/2" ■ Installation set, DN50-DN150, 2"-6" ■ Installation set, DN150-DN200, 6"-8" ■ Installation set, DN200-DN600, 8"-24" ■ Installation set, DN600-DN2000, 24"-80" ■ Installation set, DN2000-DN4000, 80"-160"
Conduit adapter set (DK9003)	<ul style="list-style-type: none"> ■ Without conduit adapter + sensor cable gland ■ Conduit adapter M20x1.5 + sensor cable gland ■ Conduit adapter NPT1/2" + sensor cable gland ■ Conduit adapter G1/2" + sensor cable gland
Coupling medium (DK9CM)	<ul style="list-style-type: none"> ■ Permanent coupling pad ■ Coupling gel



15.2 Communication-specific accessories

Accessories	Description
Commubox FXA195 HART	<p>For intrinsically safe HART communication with FieldCare via the USB interface.</p> <p> Technical Information TI00404F</p>
Commubox FXA291	<p>Connects Endress+Hauser field devices with a CDI interface (= Endress+Hauser Common Data Interface) and the USB port of a computer or laptop.</p> <p> Technical Information TI405C/07</p>
HART Loop Converter HMX50	<p>Is used to evaluate and convert dynamic HART process variables to analog current signals or limit values.</p> <p> <ul style="list-style-type: none"> ■ Technical Information TI00429F ■ Operating Instructions BA00371F </p>
Wireless HART adapter SWA70	<p>Is used for the wireless connection of field devices. The WirelessHART adapter can be easily integrated into field devices and existing infrastructures, offers data protection and transmission safety and can be operated in parallel with other wireless networks with minimum cabling complexity.</p> <p> Operating Instructions BA00061S</p>
Fieldgate FXA42	<p>Is used to transmit the measured values of connected 4 to 20 mA analog measuring devices, as well as digital measuring devices</p> <p> <ul style="list-style-type: none"> ■ Technical Information TI01297S ■ Operating Instructions BA01778S ■ Product page: www.endress.com/fxa42 </p>
Field Xpert SMT70	<p>The Field Xpert SMT70 tablet PC for device configuration enables mobile plant asset management in hazardous and non-hazardous areas. It is suitable for commissioning and maintenance staff to manage field instruments with a digital communication interface and to record progress. This tablet PC is designed as an all-in-one solution with a preinstalled driver library and is an easy-to-use, touch-sensitive tool which can be used to manage field instruments throughout their entire life cycle.</p> <p> <ul style="list-style-type: none"> ■ Technical Information TI01342S ■ Operating Instructions BA01709S ■ Product page: www.endress.com/smt70 </p>
Field Xpert SMT77	<p>The Field Xpert SMT77 tablet PC for device configuration enables mobile plant asset management in areas categorized as Ex Zone 1.</p> <p> <ul style="list-style-type: none"> ■ Technical Information TI01418S ■ Operating Instructions BA01923S ■ Product page: www.endress.com/smt77 </p>

15.3 Service-specific accessories

Accessory	Description
Applicator	<p>Software for selecting and sizing Endress+Hauser measuring devices:</p> <ul style="list-style-type: none"> Choice of measuring devices with industrial requirements Calculation of all the necessary data for identifying the optimum flowmeter: e.g. nominal diameter, pressure loss, flow velocity and accuracy. Graphic illustration of the calculation results Determination of the partial order code, administration, documentation and access to all project-related data and parameters over the entire life cycle of a project. <p>Applicator is available:</p> <ul style="list-style-type: none"> Via the Internet: https://portal.endress.com/webapp/applicator As a downloadable DVD for local PC installation.
W@M	<p>W@M Life Cycle Management</p> <p>Improved productivity with information at your fingertips. Data relevant to a plant and its components is generated from the first stages of planning and during the asset's complete life cycle.</p> <p>W@M Life Cycle Management is an open and flexible information platform with online and on-site tools. Instant access for your staff to current, in-depth data shortens your plant's engineering time, speeds up procurement processes and increases plant uptime.</p> <p>Combined with the right services, W@M Life Cycle Management boosts productivity in every phase. For more information, see: www.endress.com/lifecyclemanagement</p>
FieldCare	<p>FDT-based plant asset management tool from Endress+Hauser. It can configure all smart field units in your system and helps you manage them. By using the status information, it is also a simple but effective way of checking their status and condition.</p> <p> Operating Instructions BA00027S and BA00059S</p>
DeviceCare	<p>Tool for connecting and configuring Endress+Hauser field devices.</p> <p> Innovation brochure IN01047S</p>

15.4 System components

Accessories	Description
Memograph M graphic data manager	<p>The Memograph M graphic data manager provides information on all the relevant measured variables. Measured values are recorded correctly, limit values are monitored and measuring points analyzed. The data are stored in the 256 MB internal memory and also on a SD card or USB stick.</p> <ul style="list-style-type: none">  Technical Information TI00133R  Operating Instructions BA00247R

16 Technical data



16.1 Application

The measuring device is only suitable for flow measurement of liquids.

To ensure that the device remains in proper operating condition for its service life, use the measuring device only for media against which the process-wetted materials are sufficiently resistant.

16.2 Function and system design

Measuring principle	Proline Prosonic Flow uses a measurement method based on the transit time difference.
---------------------	---

Measuring system	<p>The measuring system consists of a transmitter and one or two sensor sets. The transmitter and sensor sets are mounted in physically separate locations. They are interconnected by sensor cables.</p> <p>The measuring system uses a measurement method based on the transit time difference. Here, the sensors work as sound generators and sound receivers. Depending on the application and version, the sensors can be arranged for a measurement via 1, 2, 3 or 4 traverses →  23.</p> <p>The transmitter serves to control the sensor sets, to prepare, process and evaluate the measuring signals, and to convert the signals to the desired output variable.</p> <p>Information on the structure of the device →  13</p>
------------------	---

16.3 Input

Measured variable	<p>Direct measured variables</p> <ul style="list-style-type: none"> ▪ Volume flow ▪ Flow velocity ▪ Sound velocity <p>Calculated measured variables</p> <p>Mass flow</p>
-------------------	---

Measuring range	<p>$v = 0$ to 15 m/s (0 to 50 ft/s)</p> <p> Measuring range depending on the sensor version.</p>
-----------------	--

Operable flow range	Over 150 : 1
---------------------	--------------

Input signal	<p>External measured values</p> <p>Interfaces that allow externally measured variables (temperature, density) to be transmitted to the measuring device are optionally available for the device.</p>
--------------	---

HART protocol

The measured values are written from the automation system to the measuring device via the HART protocol. The temperature and density measuring device must support the following protocol-specific functions:

- HART protocol
- Burst mode

Status input

Maximum input values	<ul style="list-style-type: none"> ■ DC 30 V ■ 6 mA
Response time	Configurable: 5 to 200 ms
Input signal level	<ul style="list-style-type: none"> ■ Low signal (low): DC -3 to +5 V ■ High signal (high): DC 12 to 30 V
Assignable functions	<ul style="list-style-type: none"> ■ Off ■ Reset totalizers 1-3 separately ■ Reset all totalizers ■ Flow override

16.4 Output

Output signal

Current output

Current output	Can be set as: <ul style="list-style-type: none"> ■ 4 to 20 mA NAMUR ■ 4 to 20 mA US ■ 4 to 20 mA HART ■ 0 to 20 mA
Maximum output values	<ul style="list-style-type: none"> ■ DC 24 V (no flow) ■ 22.5 mA
Load	250 to 700 Ω
Resolution	0.38 μ A
Damping	Adjustable: 0 to 999.9 s
Assignable measured variables	<ul style="list-style-type: none"> ■ Volume flow ■ Mass flow ■ Sound velocity ■ Flow velocity ■ Electronic temperature <p> The range of options increases if the measuring device has one or more application packages.</p>

Pulse/frequency/switch output

Function	<ul style="list-style-type: none"> ■ With the order code for "Output; Input", option H: output 2 can be set as a pulse or frequency output ■ With the order code for "Output; Input", option I: output 2 and 3 can be set as a pulse, frequency or switch output
Version	Passive, open collector
Maximum input values	<ul style="list-style-type: none"> ■ DC 30 V ■ 250 mA
Voltage drop	At 25 mA: \leq DC 2 V
Pulse output	
Pulse width	Adjustable: 0.05 to 2 000 ms

Maximum pulse rate	10 000 Impulse/s
Pulse value	Adjustable
Assignable measured variables	<ul style="list-style-type: none"> ▪ Volume flow ▪ Mass flow
Frequency output	
Output frequency	Adjustable: 0 to 12 500 Hz
Damping	Adjustable: 0 to 999 s
Pulse/pause ratio	1:1
Assignable measured variables	<ul style="list-style-type: none"> ▪ Volume flow ▪ Mass flow ▪ Sound velocity ▪ Flow velocity ▪ Electronic temperature
Switch output	
Switching behavior	Binary, conductive or non-conductive
Switching delay	Adjustable: 0 to 100 s
Number of switching cycles	Unlimited
Assignable functions	<ul style="list-style-type: none"> ▪ Off ▪ On ▪ Diagnostic behavior ▪ Limit value <ul style="list-style-type: none"> ▪ Volume flow ▪ Mass flow ▪ Sound velocity ▪ Flow velocity ▪ Totalizer 1-3 ▪ Electronic temperature ▪ Flow direction monitoring ▪ Status ▪ Low flow cut off

Signal on alarm

Depending on the interface, failure information is displayed as follows:

Current output 4 to 20 mA

4 to 20 mA

Failure mode	Choose from: <ul style="list-style-type: none"> ▪ 4 to 20 mA in accordance with NAMUR recommendation NE 43 ▪ 4 to 20 mA in accordance with US ▪ Min. value: 3.59 mA ▪ Max. value: 22.5 mA ▪ Freely definable value between: 3.59 to 22.5 mA ▪ Actual value ▪ Last valid value
---------------------	--

0 to 20 mA

Failure mode	Choose from: <ul style="list-style-type: none"> ▪ Maximum alarm: 22 mA ▪ Freely definable value between: 0 to 22.5 mA
---------------------	---

HART current output

Device diagnostics	Device condition can be read out via HART Command 48
---------------------------	--

Pulse/frequency/switch output

Pulse output	
Failure mode	Choose from: <ul style="list-style-type: none"> ■ Actual value ■ No pulses
Frequency output	
Failure mode	Choose from: <ul style="list-style-type: none"> ■ Actual value ■ 0 Hz ■ Defined value: 0 to 12 500 Hz
Switch output	
Failure mode	Choose from: <ul style="list-style-type: none"> ■ Current status ■ Open ■ Closed

Local display

Plain text display	With information on cause and remedial measures
Backlight	Red backlighting indicates a device error.

 Status signal as per NAMUR recommendation NE 107

Interface/protocol



- Via digital communication:
 - HART protocol
- Via service interface
 - CDI-RJ45 service interface
 - WLAN interface

Plain text display	With information on cause and remedial measures
--------------------	---

Web browser

Plain text display	With information on cause and remedial measures
--------------------	---

Light emitting diodes (LED)

Status information	Status indicated by various light emitting diodes The following information is displayed depending on the device version: <ul style="list-style-type: none"> ■ Supply voltage active ■ Data transmission active ■ Device alarm/error has occurred  Diagnostic information via light emitting diodes →  127
--------------------	--

Low flow cut off

The switch points for low flow cut off are user-selectable.

Galvanic isolation The following connections are galvanically isolated from each other:

- Inputs
- Outputs
- Power supply

The clamp-on sensors can also be mounted on cathodically protected pipes ⁷⁾. Solution available on request.

Protocol-specific data

HART

Manufacturer ID	0x11
Device type ID	0x1169
HART protocol revision	7
Device description files (DTM, DD)	Information and files under: www.endress.com
HART load	Min. 250 Ω
Dynamic variables PV, SV, TV, QV	<ul style="list-style-type: none"> ■ Read out the dynamic variables via HART command 3 ■ The measured variables can be freely assigned to the dynamic variables
Device variables	<ul style="list-style-type: none"> ■ Read out the device variables via HART command 9 ■ The measured variables can be freely assigned ■ A maximum of 8 device variables can be transmitted
System integration	

16.5 Power supply

Terminal assignment →  45

Supply voltage

Transmitter

Order code for "Power supply"	terminal voltage		Frequency range
Option L	DC 24 V	±25%	–
	AC 24 V	±25%	50/60 Hz, ±4 Hz
	AC 100 to 240 V	–15 to +10%	50/60 Hz, ±4 Hz

Power consumption





Order code for "Output"	Maximum power consumption
Option H: 4-20mA HART, pulse/frequency output, switch output	30 VA/8 W
Option I: 4-20mA HART, 2 x pulse/frequency/switch output, status input	30 VA/8 W

Current consumption



Transmitter

Order code for "Power supply"	Maximum Current consumption	Maximum switch-on current
Option L: AC 100 to 240 V	145 mA	25 A (< 5 ms)
Option L: AC/DC 24 V	350 mA	27 A (< 5 ms)

7) Only DN 50 to 4000 (2 to 160") and non-Ex

Power supply failure	<ul style="list-style-type: none"> ■ Totalizers stop at the last value measured. ■ Depending on the device version, the configuration is retained in the device memory or in the pluggable data memory (HistoROM DAT). ■ Error messages (incl. total operated hours) are stored.
Electrical connection	→  46
Potential equalization	→  49
Terminals	<p>Transmitter Supply voltage cable: plug-in spring terminals for wire cross-sections 0.5 to 2.5 mm² (20 to 14 AWG)</p>
Cable entries	<p>Cable entry thread</p> <ul style="list-style-type: none"> ■ M20 x 1.5 ■ Via adapter: <ul style="list-style-type: none"> ■ NPT ½" ■ G ½" <p>Cable gland M20 × 1.5 with cable ϕ 6 to 12 mm (0.24 to 0.47 in)</p> <p> If metal cable entries are used, use a grounding plate.</p>
Cable specification	→  44

16.6 Performance characteristics

Reference operating conditions	<ul style="list-style-type: none"> ■ Error limits following ISO/DIS 11631 ■ Specifications as per measurement report ■ Accuracy information is based on accredited calibration rigs that are traced to ISO 17025. <p> To obtain measured errors, use the <i>Applicator</i> sizing tool →  149</p>
Maximum measured error	<p>o.r. = of reading</p> <p>The measured error depends on a number of factors. A distinction is made between the measured error of the device (0.5% o.r.) and an additional installation-specific measured error (typically 1.5% o.r.) that is independent of the device.</p> <p>The installation-specific measured error depends on the installation conditions on site, such as the nominal diameter, wall thickness, real pipe geometry or medium. The sum of the two measured errors is the measured error at the measuring point.</p>

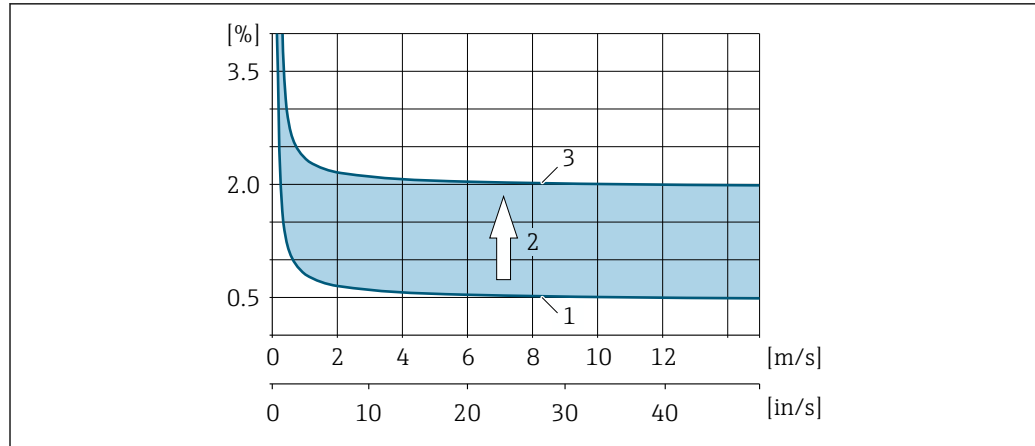

A0041972

55 Example of the measured error in a pipe with a nominal diameter DN > 200 (8")

- 1 Measured error of measuring device: 0.5% o.r. ± 3 mm/s (0.12 in/s)
- 2 Measured error due to installation conditions: typically 1.5% o.r.
- 3 Measured error at the measuring point: 0.5% o.r. ± 3 mm/s (0.12 in/s) + 1.5% o.r. = 2% o.r. ± 3 mm/s (0.12 in/s)

Measured error at the measuring point

The measured error at the measuring point is made up of the measured error of the device (0.5% o.r.) and the measured error resulting from the installation conditions on site. With a flow velocity > 0.3 m/s (1 ft/s) and a Reynolds number > 10 000, the following are typical error limits:

Nominal diameter	Device error limits	+	Installation-specific error limits (typical)	→	Error limits at the measuring point (typical)	Field calibration ¹⁾
DN 15 (½")	±0.5% o.r. ± 5 mm/s (0.20 in/s)	+	±2.5% o.r.	→	±3% o.r. ± 5 mm/s (0.20 in/s)	±0.5% o.r. ± 5 mm/s (0.20 in/s)
DN 25 to 200 (1 to 8")	±0.5% o.r. ± 7.5 mm/s (0.30 in/s)	+	±1.5% o.r.	→	±2% o.r. ± 7.5 mm/s (0.30 in/s)	±0.5% o.r. ± 7.5 mm/s (0.30 in/s)
> DN 200 (8")	±0.5% o.r. ± 3 mm/s (0.12 in/s)	+	±1.5% o.r.	→	±2% o.r. ± 3 mm/s (0.12 in/s)	±0.5% o.r. ± 3 mm/s (0.12 in/s)

1) Adjustment in relation to a reference with correction values written back to the transmitter

Measurement report

If required, the device can be supplied with a factory measurement report. A measurement is performed under reference conditions to verify the performance of the device. Here, the sensors are mounted on a pipe with a nominal diameter of DN 50 (2") or DN 100 (4").

With a flow velocity of > 0.3 m/s (1 ft/s) and a Reynolds number > 10 000, the following error limits are guaranteed with the measurement report:

Nominal diameter	Device error limits
50 (2")	±0.5% o.r. ± 5 mm/s (0.20 in/s)
100 (4")	±0.5% o.r. ± 7.5 mm/s (0.30 in/s)

i The specification applies for Reynolds numbers $Re \geq 10\,000$. Larger measured errors can occur for Reynolds numbers $Re < 10\,000$.

Example for max. measured error (volume flow)

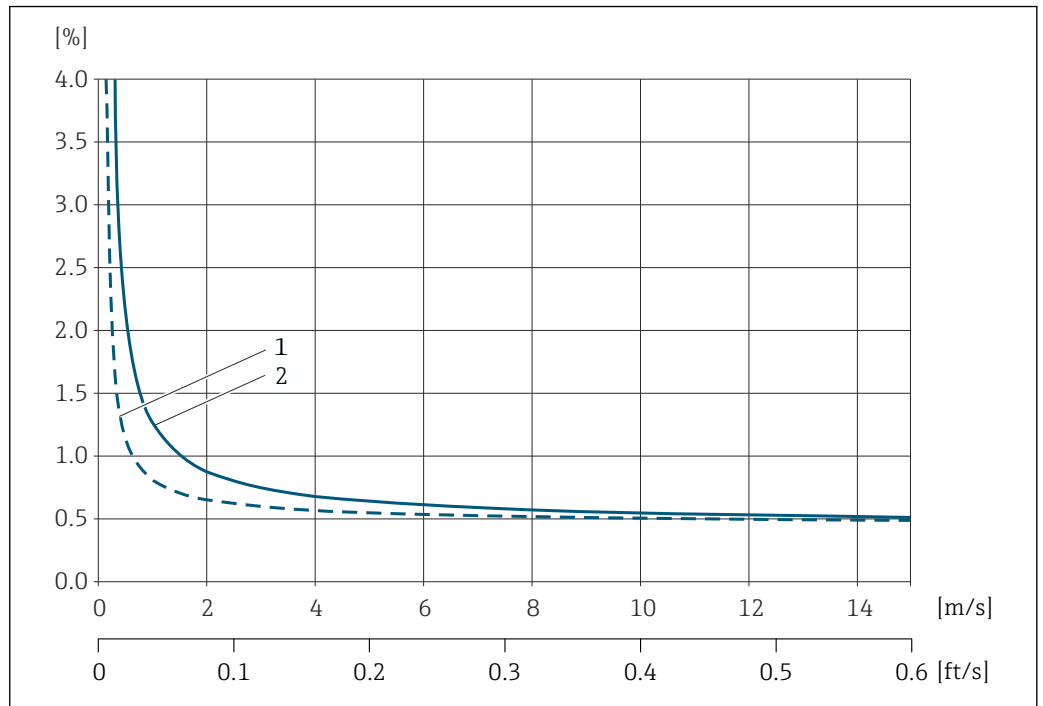

56 Example for max. measured error (volume flow) in % o.r.

- 1 Pipe diameter < DN 100 (4")
- 2 Pipe diameter ≥ DN 100 (4")

Repeatability o.r. = of reading
±0.3% for flow velocities >0.3 m/s (1 ft/s)

Influence of ambient temperature **Current output**
o.r. = of reading

Temperature coefficient	Max. ±0.005 % o.r./°C
-------------------------	-----------------------

Pulse/frequency output

Temperature coefficient	No additional effect. Included in accuracy.
-------------------------	---

16.7 Installation

Installation conditions → 19

16.8 Environment

Ambient temperature range → 27

Storage temperature The storage temperature for all components (except display modules) corresponds to the ambient temperature range →  27.

Degree of protection **Transmitter**

- IP66/67, Type 4X enclosure, suitable for pollution degree 4
- When the housing is open: IP20, Type 1 enclosure, suitable for pollution degree 2
- Display module: IP20, Type 1 enclosure, suitable for pollution degree 2

Sensor

- Standard: IP66/67, Type 4X enclosure, suitable for pollution degree 4
- Optionally available: IP68, Type 6P enclosure, suitable for pollution degree 4

External WLAN antenna

IP67

Vibration- and shock-resistance **Vibration sinusoidal, according to IEC 60068-2-6**

- 2 to 8.4 Hz, 7.5 mm peak
- 8.4 to 2 000 Hz, 2 g peak for transmitter, 1 g peak for sensor

Vibration broad-band random, according to IEC 60068-2-64

- 10 to 200 Hz, 0.01 g²/Hz
- 200 to 2 000 Hz, 0.003 g²/Hz
- Total: 2.70 g rms

Shock half-sine, according to IEC 60068-2-27

6 ms 50 g

Rough handling shocks according to IEC 60068-2-31

Electromagnetic compatibility (EMC)

- As per IEC/EN 61326
- Complies with emission limits for industry as per EN 55011 (Class A)

 Details are provided in the Declaration of Conformity.

16.9 Process

Medium temperature range

Sensor version	Frequency	Temperature
C-030-A	0.3 MHz	-20 to +80 °C (-4 to +176 °F) -40 to +80 °C (-40 to +176 °F)
C-050-A	0.5 MHz	-20 to +80 °C (-4 to +176 °F)
C-100-A	1 MHz	-20 to +80 °C (-4 to +176 °F)
C-200-A	2 MHz	-20 to +80 °C (-4 to +176 °F)
C-500-A	5 MHz	-20 to +80 °C (-4 to +176 °F) -40 to +80 °C (-40 to +176 °F) 0 to +130 °C (+32 to +266 °F)
C-100-B	1 MHz	-40 to +80 °C (-40 to +176 °F)
C-200-B	2 MHz	-40 to +80 °C (-40 to +176 °F)

Sensor version	Frequency	Temperature
C-100-C	1 MHz	0 to +130 °C (+32 to +266 °F)
C-200-C	2 MHz	0 to +130 °C (+32 to +266 °F)

Sound velocity range 600 to 2 100 m/s (1 969 to 6 890 ft/s)

Medium pressure range No pressure limitation. Nevertheless, for correct measurement, the static pressure of the medium must be higher than the vapor pressure.

Pressure loss There is no pressure loss.

16.10 Mechanical construction

Design, dimensions  For the dimensions and installed lengths of the device, see the "Technical Information" document, "Mechanical construction" section

Weight Weight specifications excluding packaging material.

Transmitter

- Proline 400 polycarbonate plastic: 1.2 kg (2.65 lb)
- Proline 400 aluminum, coated: 6.0 kg (13.2 lb)

Sensor

Including mounting material

- DN 15 to 65 (½ to 2½"): 1.2 kg (2.65 lb)
- DN 50 to 4000 (2 to 160"): 2.8 kg (6.17 lb)

Materials

Remote version (wall-mount housing)

- Order code for "Housing", option **P** "Remote, alu, coated": Aluminum, AlSi10Mg, coated
- Order code for "Housing", option **N**: polycarbonate plastic
- Window material:
 - For order code for "Housing", option **P**: glass
 - For order code for "Housing", option **N**: plastic

Cable entries/cable glands

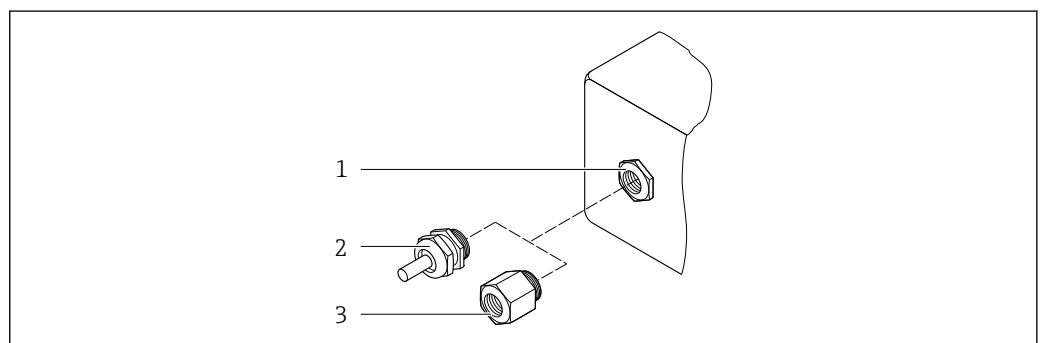

 57 Possible cable entries/cable glands

- 1 Female thread M20 × 1.5
- 2 Cable gland M20 × 1.5
- 3 Adapter for cable entry with female thread G ½" or NPT ½"

remote version

Cable entry/cable gland	Material
Cable gland M20 × 1.5	<ul style="list-style-type: none"> ■ Plastic ■ Nickel-plated brass
Cable gland of sensor cable	Nickel-plated brass
Power cable gland	Plastic
Adapter for cable entry with female thread G ½" or NPT ½"	Nickel-plated brass

Sensor - transmitter cable

 UV rays can impair the cable outer sheath. Protect the cable from exposure to sun as much as possible.

DN 15 to 65 (½ to 2½"):

Sensor cable: TPE

- Cable sheath: TPE
- Cable plug: nickel-plated brass

DN 50 to 4000 (2 to 160"):

- Sensor cable, TPE halogen-free
 - Cable sheath: TPE halogen-free
 - Cable plug: nickel-plated brass
- Sensor cable PTFE
 - Cable sheath: PTFE
 - Cable plug: stainless steel 1.4301 (304), 1.4404 (316L)

Ultrasonic transducer

- Holder: stainless steel 1.4301 (304), 1.4404 (316L)
- Housing: stainless steel 1.4301 (304), 1.4404 (316L)
- Strapping bands/bracket: stainless steel 1.4301 (304), 1.4404 (316L)
- Contact surfaces: chemically stable plastic

Accessories

External WLAN antenna

- Antenna: ASA plastic (acrylic ester-styrene-acrylonitrile) and nickel-plated brass
- Adapter: Stainless steel and nickel-plated brass
- Cable: Polyethylene
- Plug: Nickel-plated brass
- Angle bracket: Stainless steel

16.11 Operability

Languages

Can be operated in the following languages:

- Via local operation:
 - English, German, French, Spanish, Italian, Dutch, Portuguese, Polish, Russian, Turkish, Chinese, Japanese, Bahasa (Indonesian), Vietnamese, Czech, Swedish
- Via "FieldCare", "DeviceCare" operating tool:
 - English, German, French, Spanish, Italian, Chinese, Japanese
- Via Web browser
 - English, German, French, Spanish, Italian, Dutch, Portuguese, Polish, Russian, Turkish, Chinese, Japanese, Bahasa (Indonesian), Vietnamese, Czech, Swedish

Local operation

Via display module

Equipment:

- Standard features 4-line, illuminated, graphic display; touch control
- Order code for "Display; operation", option G "4-line, illuminated; Touch Control +WLAN" offers standard equipment features in addition to access via Web browser

 Information about WLAN interface →  72

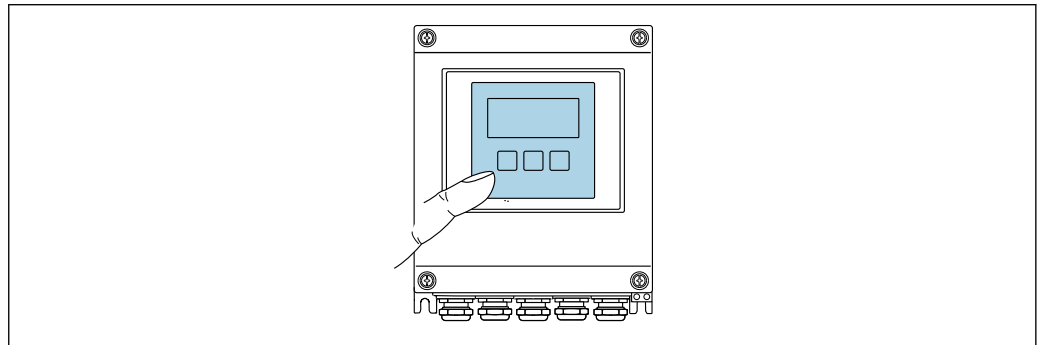



 58 Operation with touch control

Display elements

- 4-line, illuminated, graphic display
- White background lighting; switches to red in event of device errors
- Format for displaying measured variables and status variables can be individually configured
- Permitted ambient temperature for the display: -20 to +60 °C (-4 to +140 °F)
The readability of the display may be impaired at temperatures outside the temperature range.

Operating elements

- External operation via touch control (3 optical keys) without opening the housing: , , 
- Operating elements also accessible in the various zones of the hazardous area

Remote operation

→  72

Service interface

→  72

Supported operating tools

Different operating tools can be used for local or remote access to the measuring device. Depending on the operating tool used, access is possible with different operating units and via a variety of interfaces.

Supported operating tools	Operating unit	Interface	Additional information
Web browser	Notebook, PC or tablet with Web browser	<ul style="list-style-type: none"> ■ CDI-RJ45 service interface ■ WLAN interface 	Special Documentation for the device
DeviceCare SFE100	Notebook, PC or tablet with Microsoft Windows system	<ul style="list-style-type: none"> ■ CDI-RJ45 service interface ■ WLAN interface ■ Fieldbus protocol 	→  149

Supported operating tools	Operating unit	Interface	Additional information
FieldCare SFE500	Notebook, PC or tablet with Microsoft Windows system	<ul style="list-style-type: none"> ■ CDI-RJ45 service interface ■ WLAN interface ■ Fieldbus protocol 	→  149
Device Xpert	Field Xpert SFX 100/350/370	Fieldbus protocol HART	Operating Instructions BA01202S Device description files: Use update function of handheld terminal

 Other operating tools based on FDT technology with a device driver such as DTM/iDTM or DD/EDD can be used for device operation. These operating tools are available from the individual manufacturers. Integration into the following operating tools, among others, is supported:

- FactoryTalk AssetCentre (FTAC) from Rockwell Automation → www.rockwellautomation.com
- Process Device Manager (PDM) from Siemens → www.siemens.com
- Asset Management Solutions (AMS) from Emerson → www.emersonprocess.com
- FieldCommunicator 375/475 from Emerson → www.emersonprocess.com
- Field Device Manager (FDM) from Honeywell → www.honeywellprocess.com
- FieldMate from Yokogawa → www.yokogawa.com
- PACTWare → www.pactware.com

The related device description files are available: www.endress.com → Downloads

Web server

Thanks to the integrated Web server the device can be operated and configured via a Web browser and via a standard Ethernet switch (RJ45) or via a WLAN interface. The structure of the operating menu is the same as the menu on the local display. In addition to the measured values, status information about the device is also displayed and allows the user to monitor the status of the device. Furthermore the device data can be managed and the network parameters can be configured.

A device that has a WLAN interface (can be ordered as an option) is required for the WLAN connection: order code for "Display", option G "4-line, illuminated; Touch Control +WLAN". The device acts as an Access Point and enables communication by computer or a mobile handheld terminal.

Supported functions

Data exchange between the operating unit (such as a notebook for example) and the measuring device:

- Upload the configuration from the measuring device (XML format, create configuration back-up)
- Save the configuration to the measuring device (XML format, restore configuration)
- Export event list (.csv file)
- Export parameter settings (.csv file or PDF file, document the measuring point configuration)
- Export the Heartbeat verification log (PDF file, only available with the "Heartbeat Verification" application package)
- Flash firmware version for device firmware upgrade, for instance
- Download driver for system integration
- Display up to 1000 saved measured values (only available with the **Extended HistoROM** application package →  165)

 Web server special documentation

HistoROM data management The measuring device features HistoROM data management. HistoROM data management comprises both the storage and import/export of key device and process data, making operation and servicing far more reliable, secure and efficient.

Additional information on the data storage concept

There are different types of data storage units in which device data are stored and used by the device:

	HistoROM backup	T-DAT	S-DAT
Available data	<ul style="list-style-type: none"> ▪ Event logbook such as diagnostic events for example ▪ Device firmware package 	<ul style="list-style-type: none"> ▪ Measured value logging ("Extended HistoROM" order option) ▪ Current parameter data record (used by firmware at run time) ▪ Peakhold indicator (min/max values) ▪ Totalizer values 	<ul style="list-style-type: none"> ▪ Sensor data: etc. ▪ Serial number ▪ Device configuration (e.g. SW options, fixed I/O or multi I/O)
Storage location	Fixed on the user interface board in the connection compartment	Attachable to the user interface board in the connection compartment	Fixed on the sensor connection board

Data backup

Automatic

- The most important device data (sensor and transmitter) are automatically saved in the DAT modules
- If the transmitter or measuring device is replaced: once the T-DAT containing the previous device data has been exchanged, the new measuring device is ready for operation again immediately without any errors
- If the sensor is replaced: once the sensor has been replaced, new sensor data are transferred from the S-DAT in the measuring device and the measuring device is ready for operation again immediately without any errors

Data transmission

Manual

Transfer of a device configuration to another device using the export function of the specific operating tool, e.g. with FieldCare, DeviceCare or Web server: to duplicate the configuration or to store in an archive (e.g. for backup purposes)

Event list

Automatic

- Chronological display of up to 20 event messages in the events list
- If the **Extended HistoROM** application package (order option) is enabled: up to 100 event messages are displayed in the events list along with a time stamp, plain text description and remedial measures
- The events list can be exported and displayed via a variety of interfaces and operating tools e.g. DeviceCare, FieldCare or Web server

Data logging

Manual

If the **Extended HistoROM** application package (order option) is enabled:



- Record up to 1 000 measured values via 1 to 4 channels
- User configurable recording interval
- Record up to 250 measured values via each of the 4 memory channels
- Export the measured value log via a variety of interfaces and operating tools e.g. FieldCare, DeviceCare or web server

16.12 Certificates and approvals

Current certificates and approvals for the product are available via the Product Configurator at www.endress.com.

1. Select the product using the filters and search field.
2. Open the product page.

The **Configuration** button opens the Product Configurator.



CE mark	<p>The device meets the legal requirements of the applicable EU Directives. These are listed in the corresponding EU Declaration of Conformity along with the standards applied.</p> <p>Endress+Hauser confirms successful testing of the device by affixing to it the CE mark.</p>
UKCA marking	<p>The device meets the legal requirements of the applicable UK regulations (Statutory Instruments). These are listed in the UKCA Declaration of Conformity along with the designated standards. By selecting the order option for UKCA marking, Endress+Hauser confirms a successful evaluation and testing of the device by affixing the UKCA mark.</p> <p>Contact address Endress+Hauser UK: Endress+Hauser Ltd. Floats Road Manchester M23 9NF United Kingdom www.uk.endress.com</p>
RCM mark	<p>The measuring system meets the EMC requirements of the "Australian Communications and Media Authority (ACMA)".</p>
Ex approval	<p>The devices are certified for use in hazardous areas and the relevant safety instructions are provided in the separate "Control Drawing" document. Reference is made to this document on the nameplate.</p>
HART certification	<p>HART interface</p> <p>The measuring device is certified and registered by the FieldComm Group. The measuring system meets all the requirements of the following specifications:</p> <ul style="list-style-type: none"> ■ Certified according to HART 7 ■ The device can also be operated with certified devices of other manufacturers (interoperability)
Radio approval	<p>The measuring device has radio approval.</p> <p> For detailed information regarding radio approval, see the Special Documentation →  167</p>
Other standards and guidelines	<ul style="list-style-type: none"> ■ EN 60529 Degrees of protection provided by enclosures (IP code) ■ EN 61010-1 Safety requirements for electrical equipment for measurement, control and laboratory use - general requirements ■ IEC/EN 61326-2-3 Emission in accordance with Class A requirements. Electromagnetic compatibility (EMC requirements).

- ANSI/ISA-61010-1 (82.02.01)
Safety Requirements for Electrical Equipment for Measurement, Control and Laboratory Use - Part 1 General Requirements
- CAN/CSA-C22.2 No. 61010-1-12
Safety Requirements for Electrical Equipment for Measurement, Control and Laboratory Use - Part 1 General Requirements
- NAMUR NE 32
Data retention in the event of a power failure in field and control instruments with microprocessors
- NAMUR NE 43
Standardization of the signal level for the breakdown information of digital transmitters with analog output signal.
- NAMUR NE 53
Software of field devices and signal-processing devices with digital electronics
- NAMUR NE 105
Specifications for integrating fieldbus devices in engineering tools for field devices
- NAMUR NE 107
Self-monitoring and diagnosis of field devices
- NAMUR NE 131
Requirements for field devices for standard applications

16.13 Application packages

Many different application packages are available to enhance the functionality of the device. Such packages might be needed to address safety aspects or specific application requirements.

The application packages can be ordered with the device or subsequently from Endress+Hauser. Detailed information on the order code in question is available from your local Endress+Hauser sales center or on the product page of the Endress+Hauser website: www.endress.com.

 Detailed information on the application packages:
Special Documentation for the device →  167



Diagnostics functions

Package	Description
Extended HistoROM	<p>Comprises extended functions concerning the event log and the activation of the measured value memory.</p> <p>Event log: Memory volume is extended from 20 message entries (standard version) to up to 100 entries.</p> <p>Data logging (line recorder):</p> <ul style="list-style-type: none"> ▪ Memory capacity for up to 1000 measured values is activated. ▪ 250 measured values can be output via each of the 4 memory channels. The recording interval can be defined and configured by the user. ▪ Measured value logs can be accessed via the local display or operating tool e.g. FieldCare, DeviceCare or Web server.

Heartbeat Technology	Package	Description
	Heartbeat Verification +Monitoring	<p>Heartbeat Verification Meets the requirement for traceable verification to DIN ISO 9001:2008 Chapter 7.6 a) "Control of monitoring and measuring equipment".</p> <ul style="list-style-type: none"> Functional testing in the installed state without interrupting the process. Traceable verification results on request, including a report. Simple testing process via local operation or other operating interfaces. Clear measuring point assessment (pass/fail) with high test coverage within the framework of manufacturer specifications. Extension of calibration intervals according to operator's risk assessment. <p>Heartbeat Monitoring Continuously supplies data, which are characteristic of the measuring principle, to an external condition monitoring system for the purpose of preventive maintenance or process analysis. These data enable the operator to:</p> <ul style="list-style-type: none"> Draw conclusions - using these data and other information - about the impact the measuring application has on the measuring performance over time. Schedule servicing in time. Monitor the process or product quality, e.g. gas pockets.

FlowDC	Package	Description
	FlowDC	Flow disturbance compensation Shortens the necessary inlet run while maintaining the specified accuracy.

16.14 Accessories

 Overview of accessories available for order →  147

16.15 Documentation

-  For an overview of the scope of the associated Technical Documentation, refer to the following:
- W@M Device Viewer* (www.endress.com/deviceviewer): Enter the serial number from the nameplate
 - Endress+Hauser Operations App*: Enter the serial number from the nameplate or scan the matrix code on the nameplate

Standard documentation **Brief Operating Instructions**

Brief Operating Instructions for the sensor

Measuring device	Documentation code
Proline Prosonic Flow W	KA01512D

Brief Operating Instructions for the transmitter

Measuring device	Documentation code
Proline 400	KA01510D

Technical Information

Measuring device	Documentation code
Prosonic Flow W 400	TI01568D

Description of device parameters

Measuring device	Documentation code
Prosonic Flow W 400	HART GP01167D

Supplementary device-
dependent documentation

Special Documentation

Contents	Documentation code
Radio approvals for WLAN interface for A309/A310 display module	SD01793D
FlowDC	SD02691D
Heartbeat Technology	SD02712D
Web server	SD02713D

Installation Instructions

Content	Comment
Installation instructions for spare part sets and accessories	<ul style="list-style-type: none"> ▪ Access the overview of all the available spare part sets via <i>W@M Device Viewer</i> →  145 ▪ Accessories available for order with Installation Instructions →  147

Index

A

- Access authorization to parameters
 - Read access 65
 - Write access 65
- Access code 65
 - Incorrect input 65
- Adapting the diagnostic behavior 133
- Adapting the status signal 133
- Ambient temperature
 - Influence 157
- Ambient temperature range 27
- AMS Device Manager 76
 - Function 76
- Application 150
- Application packages 165
- Applicator 150
- Approvals 164

B

- Burst mode 79

C

- Cable entries
 - Technical data 155
- Cable entry
 - Degree of protection 51
- CE mark 10, 164
- Certificates 164
- Check
 - Connection 51
 - Installation status 88
 - Mounting 42
- Checklist
 - Post-connection check 51
 - Post-mounting check 42
- Cleaning
 - Exterior cleaning 144
- Commissioning 81
 - Advanced settings 101
 - Configuring the measuring device 81
- Communication-specific data 77
- Connecting cable 44
- Connecting the measuring device 46
- Connection
 - see Electrical connection
- Connection preparations 46
- Connection tools 44
- Context menu
 - Calling up 60
 - Closing 60
 - Explanation 60
- Coupling medium
 - Coupling pad or coupling gel 34, 36, 38
- Current consumption 154

D

- Date of manufacture 16
- Declaration of Conformity 10
- Define access code 113
- Degree of protection 51, 158
- Design
 - Measuring device 14
- Device components 14
- Device description files 77
- Device documentation
 - Supplementary documentation 8
- Device locking, status 116
- Device name
 - Sensor 16
 - Transmitter 16
- Device repair 145
- Device revision 77
- Device type ID 77
- DeviceCare 75
 - Device description file 77
- Diagnostic behavior
 - Explanation 129
 - Symbols 129
- Diagnostic information
 - Design, description 129, 132
 - DeviceCare 132
 - FieldCare 132
 - Light emitting diodes 127
 - Local display 128
 - Overview 134
 - Remedial measures 134
 - Web browser 130
- Diagnostic list 138
- Diagnostic message 128
- Diagnostics
 - Symbols 128
- Dimensions 23
- DIP switch
 - see Write protection switch
- Direct access 62
- Direct access code 57
- Disabling write protection 113
- Display
 - see Local display
- Display area
 - For operational display 55
 - In the navigation view 57
- Display values
 - For locking status 116
- Disposal 146
- Document
 - Function 6
 - Symbols 6
- Document function 6
- Document information 6

E

Electrical connection	
Commubox FXA195 (USB)	72
Degree of protection	51
Field Communicator 475	72
Field Xpert SFX350/SFX370	72
Measuring device	44
Operating tool (e.g. FieldCare, AMS Device Manager, SIMATIC PDM)	72
Operating tools	
Via HART protocol	72
Via service interface (CDI-RJ45)	72
Via WLAN interface	72
VIATOR Bluetooth modem	72
Web server	72
WLAN interface	72
Electromagnetic compatibility	158
Enabling write protection	113
Enabling/disabling the keypad lock	66
Endress+Hauser services	
Maintenance	144
Repair	145
Environment	
Storage temperature	158
Vibration- and shock-resistance	158
Error messages	
see Diagnostic messages	
Event list	139
Event logbook	139
Ex approval	164
Extended order code	
Sensor	16
Transmitter	16
Exterior cleaning	144

F

Field of application	
Residual risks	9
Field Xpert SMT70	75
Field Xpert SMT77	76
FieldCare	74
Device description file	77
Establishing a connection	74
Function	74
User interface	75
Filtering the event logbook	140
Firmware	
Release date	77
Version	77
Firmware history	143
Flow direction	20
FlowDC	21
Function check	81
Function scope	
AMS Device Manager	76
SIMATIC PDM	76
Functions	
see Parameters	

G

Galvanic isolation	154
------------------------------	-----

H

Hardware write protection	114
HART certification	164
HART protocol	
Device variables	77
Measured variables	77
Help text	
Calling up	63
Closing	63
Explanation	63

I

I/O electronics module	14, 48
Identifying the measuring device	15
Incoming acceptance	15
Influence	
Ambient temperature	157
Inlet runs	20
Input	150
Input mask	58
Inspection	
Received goods	15
Installation conditions	
Dimensions	23
Intended use	9

L

Languages, operation options	160
Line recorder	122
Local display	161
Editing view	58
Navigation view	56
see Diagnostic message	
see In alarm condition	
see Operational display	
Low flow cut off	153

M

Main electronics module	14
Maintenance	144
Maintenance tasks	144
Manufacturer ID	77
Materials	159
Maximum measured error	155
Measured variables	
Calculated	150
Measured	150
see Process variables	
Measuring and test equipment	144
Measuring device	
Configuration	81
Conversion	145
Design	14
Disposal	146
Preparing for electrical connection	46
Preparing for mounting	28

Removing	146
Repairs	145
Switch-on	81
Measuring principle	150
Measuring range	150
Measuring system	150
Menu	
Diagnostics	137
Setup	82
Menus	
For measuring device configuration	81
For specific settings	101
Mounting	19
Mounting dimensions	
see Dimensions	
Mounting location	19
Mounting preparations	28
Mounting requirements	
Inlet and outlet runs	20
Mounting location	19
Orientation	20
Mounting tool	28
N	
Nameplate	
Sensor	16
Transmitter	16
Navigation path (navigation view)	56
Navigation view	
In the submenu	56
In the wizard	56
Numeric editor	58
O	
Operable flow range	150
Operating elements	60, 129
Operating keys	
see Operating elements	
Operating menu	
Menus, submenus	53
Structure	53
Submenus and user roles	54
Operating philosophy	54
Operation	21, 116
Operation methods	52
Operation options	52
Operational display	55
Operational safety	10
Order code	16
Orientation (vertical, horizontal)	20
Outlet runs	20
Output	151
Output signal	151
P	
Packaging disposal	18
Parameter	
Changing	64
Entering a value	64

Parameter settings	
Administration (Submenu)	110
Advanced setup (Submenu)	102
Burst configuration 1 to n (Submenu)	79
Current output 1 (Wizard)	91
Data logging (Submenu)	122
Define access code (Wizard)	109
Device information (Submenu)	141
Diagnostics (Menu)	137
Display (Submenu)	104
Display (Wizard)	97
For the status input	89
Heartbeat base settings (Submenu)	109
Input values (Submenu)	118
Installation status (Submenu)	88
Low flow cut off (Submenu)	99
Measuring point (Wizard)	84
Output values (Submenu)	119
Process variables (Submenu)	117
Pulse/frequency/switch output 1 to n (Wizard)	93, 94, 95
Reset access code (Submenu)	110
Sensor adjustment (Submenu)	102
Setup (Menu)	82
Simulation (Submenu)	111
Status input (Submenu)	89
System units (Submenu)	83
System values (Submenu)	117
Totalizer (Submenu)	120
Totalizer 1 to n (Submenu)	102
Totalizer handling (Submenu)	120
Web server (Submenu)	71
WLAN settings (Wizard)	106
Performance characteristics	155
Post-connection check (checklist)	51
Post-installation check	81
Post-mounting check (checklist)	42
Potential equalization	49
Power consumption	154
Power supply failure	155
Pressure loss	159
Product safety	10
Protecting parameter settings	113
R	
Radio approval	164
RCM mark	164
Read access	65
Reading off measured values	116
Recalibration	144
Reference operating conditions	155
Registered trademarks	8
Remedial measures	
Calling up	130
Closing	130
Remote operation	161
Remote version	
Connecting the signal cables	46

- Repair 145
 - Notes 145
- Repair of a device 145
- Repeatability 157
- Replacement
 - Device components 145
- Requirements for personnel 9
- Return 145
- S**
- Safety 9
- Sensor set selection and arrangement 23
- Serial number 16
- Setting the operating language 81
- Settings
 - Adapting the measuring device to the process conditions 120
 - Administration 109
 - Advanced display configurations 104
 - Current output 91
 - Device reset 141
 - Local display 97
 - Low flow cut off 99
 - Measuring point 84
 - Operating language 81
 - Pulse output 93
 - Pulse/frequency/switch output 92, 94
 - Resetting the totalizer 120
 - Sensor adjustment 102
 - Simulation 111
 - Status input 89
 - Switch output 95
 - System units 83
 - Tag name 82
 - Totalizer 102
 - Totalizer reset 120
 - WLAN 106
- Show data logging 122
- Signal on alarm 152
- SIMATIC PDM 76
 - Function 76
- Software release 77
- Sound velocity range 159
- Spare part 145
- Spare parts 145
- Special connection instructions 49
- Standards and guidelines 164
- Status area
 - For operational display 55
 - In the navigation view 57
- Status signals 128, 131
- Storage concept 163
- Storage conditions 18
- Storage temperature 18
- Storage temperature range 158
- Structure
 - Operating menu 53
- Submenu
 - Administration 109, 110
- Advanced setup 101, 102
- Burst configuration 1 to n 79
- Data logging 122
- Device information 141
- Display 104
- Event list 139
- Heartbeat base settings 109
- Heartbeat setup 108
- Input values 118
- Installation status 88
- Low flow cut off 99
- Measured values 116
- Output values 119
- Overview 54
- Process variables 117
- Reset access code 110
- Sensor adjustment 102
- Simulation 111
- Status input 89
- System units 83
- System values 117
- Totalizer 120
- Totalizer 1 to n 102
- Totalizer handling 120
- Web server 71
- Supply voltage 154
- Symbols
 - For communication 55
 - For correction 58
 - For diagnostic behavior 55
 - For locking 55
 - For measured variable 55
 - For measurement channel number 55
 - For menus 57
 - For parameters 57
 - For status signal 55
 - For submenu 57
 - For wizard 57
 - In the status area of the local display 55
 - In the text and numeric editor 58
- System design
 - Measuring system 150
 - see Measuring device design
- System integration 77
- T**
- Technical data, overview 150
- Temperature range
 - Ambient temperature 27
 - Ambient temperature range for display 161
 - Medium temperature 158
 - Storage temperature 18
- Terminal assignment 45, 46, 48
- Terminals 155
- Text editor 58
- Tool
 - For mounting 28
- Tool tip
 - see Help text

Tools	
Electrical connection	44
Transport	18
Totalizer	
Configuring	102
Transmitter	
Connecting the signal cables	48
Turning the display module	42
Transporting the measuring device	18
Troubleshooting	
General	125
Turning the display module	42
U	
UKCA marking	164
Use of the measuring device	
Borderline cases	9
Incorrect use	9
see Intended use	
User interface	
Current diagnostic event	137
Previous diagnostic event	137
User roles	54
V	
Version data for the device	77
Vibration- and shock-resistance	158
W	
W@M	144, 145
W@M Device Viewer	15, 145
Weight	
Transport (notes)	18
Wizard	
Current output 1	91
Define access code	109
Display	97
Low flow cut off	99
Measuring point	84
Pulse/frequency/switch output 1 to n	93, 94, 95
WLAN settings	106
WLAN settings	106
Workplace safety	10
Write access	65
Write protection	
Via access code	113
Via write protection switch	114
Write protection switch	114



71542315

www.addresses.endress.com
