



OPERATING INSTRUCTION MANUAL

Model ES-5

Toroidal 4-20 mA Output Probe

N116-127 REV. 3

Aquametrix, by Water Analytics Inc.
100 School Street
Andover, MA 01810

Tel: (978) 749-9949
Toll Free: (855) PH-PROBE
Fax: (978) 749-9961
www.AquaMetrix.com

ES-5 Toroidal Sensor Manual

Table of Contents

1	General Information.....	3
2	Specifications.....	3
3	Introduction to Conductivity.....	3
3.1	What is Conductivity?	3
3.2	Principle of Toroidal Cell Operation	6
3.3	Advantages of the Electrodeless Conductivity System	6
3.4	Temperature effects.....	6
4	Installation	6
4.1	Electrode Connections	6
4.2	Positioning of the Sensor.....	7
5	Operation	7
5.1	Calibration.....	7
5.2	Sample Requirements	7
5.3	Measurement.....	8
5.4	Cleaning Methods	8

1 General Information

The ES-5 Conductivity Monitoring System consists of:

1. A loop powered micro-transmitter and an electrodeless conductivity sensor combined into a single package. The probe consists of two measuring toroidal coils and a 4/20 current loop calibrated transmitter.
2. RTD PT100 built into the sensor to provide Temperature Compensation.

Applications include water treatment, cooling tower and water monitoring.

2 Specifications

Measuring Method	Toroidal
Range ES-5-C-1	0-10 mS/cm
Range ES-5-C-2	0/100 mS/cm
Range ES-5-C-3	0/1000 mS/cm
Power Supply	11/30 VDC
Current Loop	4/20 mA isolated
Load	600 Ω max. @ 24 VDC
Installation	In-line or Immersion
Cell	Inductive
Temperature Compensation	RTD PT100
Maximum Operating Temperature	50 °C for part in contact with the liquid
Temperature Coefficient	2.2%/°C
Temperature Reference	25 °C
Maximum Pressure	10 bar at 25 °C
Length	207 mm
Thread	1.5" MNPT
Materials	CPVC (Kynar upon special request)
Cable Length	3 meters (other upon request)

3 Introduction to Conductivity

3.1 What is Conductivity?

Conductivity (or specifically electrolytic conductivity) is defined as the ability of a substance to conduct electric current. It is the reciprocal of the more commonly encountered term, resistivity. All substances possess conductivity to some degree, but the amount varies widely, ranging from extremely low (insulators such as benzene, glass) to very high (silver, copper, and metals in general). Most industrial

interest is in the conductivity measurement of liquids. Electric current will readily flow through some liquids. The less ordered arrangement of the liquid molecules is not conducive to free electron movement. Therefore, another sort of charged particle must serve this purpose if any current is to flow at all. In solvents where electrical conductance occurs, notably in water, *ionization* will provide the needed carriers. Ionization refers to the tendency of most soluble inorganic compounds to partially or completely separate into two or more elemental components, called ions, having opposite electrical charges. These charged particles, or ions, act as current carriers producing *electrolytic* current flow. It is the physical characteristics of the carriers as much as that of the medium that determines electrical conductance of a solution. These solutions have conductivities approximately midway between insulators and metallic conductors. This conductivity can be measured quite easily by electronic means, and this offers a simple test, which can tell much about the quality of the water, or the makeup of the solution. A broad line of conductivity equipment is available to measure liquids ranging from ultrapure water (low conductivity) to concentrated chemical streams (high).

Advantages and Constraints of Conductivity Measurement

In general, conductivity offers a fast, reliable, nondestructive, inexpensive and durable means of measuring the ionic content of a sample. Reliability and repeatability are excellent.

The principle drawback of conductivity is that it is a nonspecific measurement; it cannot distinguish between different types of ions, giving instead a reading proportional to the combined effect of all ions present. Therefore it must be applied with some prior knowledge of the solution composition or used in relatively pure (single solute) solutions to be successful.

Units of Conductivity

The units of measurement used to describe conductivity and resistivity are quite fundamental and are frequently misused. Once the units are known, various waters can be quantitatively described.

The basic unit of resistance is the familiar ohm. Conductance is the reciprocal of resistance, and its basic unit is the Siemen, formerly called mho. In discussions of bulk material, it is convenient to talk of its specific conductance, now commonly called its conductivity. This is the conductance as measured between the opposite faces of a 1-cm cube of the material. This measurement has units of siemens/cm. The units microSiemens/cm ($\mu\text{S}/\text{cm}$) and milliSiemens/cm (mS/cm) are most commonly used to describe the conductivity of aqueous solutions. The corresponding terms for specific resistance (or resistivity) are ohm-cm ($\Omega\text{-cm}$), megaohm-cm ($\text{M}\Omega\text{-cm}$) and kilohm-cm ($\text{k}\Omega\text{-cm}$).

Users of ultrapure water prefer to use resistivity units of $\text{M}\Omega\text{-cm}$, because measurement in these units span the typical range of interest. These same users frequently use $\text{k}\Omega\text{-cm}$ when dealing with less pure water such as tap water. Others, however, use the units of S/cm and mS/cm when dealing with any stream from quite pure to very concentrated chemical solutions. In these applications, the use of conductivity has the advantage of an almost direct relationship with impurities, especially at low concentration. Hence, a rising conductivity reading shows increasing impurities, or a generally increasing concentration in the case of a chemical stream (with some exceptions in concentrated solutions). See Table 1 for a comparison of resistance and conductivity

Table 1 - Conductivity - Resistivity - TDS Conversion

Conductivity ($\mu\text{S}/\text{cm}$)	Resistivity ($\Omega\text{-cm}$)	Dissolved Solids (ppm)
0.056	18000000	0.028
0.084	12000000	0.042
0.167	6000000	0.083
1.00	100000	0.500
2.50	400000	1.25
20.0	50000	10.0
200	5000	100
2000	500	1000
20000	50	10000

Table 2 lists conductivity value of common aqueous solutions. Conductivity is approximately proportional to concentration of ions from salts but is highly non-linear as a function of concentration for acids and bases.

Table 2 - Conductivity of Various Aqueous Solutions at 25 °C

Solution	Conductivity	Resistivity
Pure Water	0.055 $\mu\text{S}/\text{cm}$	18.3 $\text{M}\Omega\text{-cm}$
Power Plant Boiler Water	1.0 $\mu\text{S}/\text{cm}$	1 $\text{M}\Omega\text{-cm}$
Distilled Water	0.5 $\mu\text{S}/\text{cm}$	2 $\text{M}\Omega\text{-cm}$
Deionized Water	0.1-10 $\mu\text{S}/\text{cm}$	0.1-10 $\text{M}\Omega\text{-cm}$
Demineralized Water	1-80 $\mu\text{S}/\text{cm}$	0.01-1 $\text{M}\Omega\text{-cm}$
Mountain Water	10 $\mu\text{S}/\text{cm}$	0.1 $\text{M}\Omega\text{-cm}$
Drinking Water	0.5-1 mS/cm	1-2 $\text{K}\Omega\text{-cm}$
Wastewater	0.9-9 mS/cm	0.1-1 $\text{K}\Omega\text{-cm}$
KCl Solution (0.01M)	1.4 mS/cm	0.7 $\text{K}\Omega\text{-cm}$
Potable Water Maximum	1.5 mS/cm	0.7 $\text{K}\Omega\text{-cm}$
Brackish Water	1-80 mS/cm	0.01-1 $\text{K}\Omega\text{-cm}$
Industrial Process Water	7-140 mS/cm	Rarely Stated
Ocean Water	53 mS/cm	Rarely Stated
10% NaOH	355 mS/cm	Rarely Stated
10% H_2SO_4	432 mS/cm	Rarely Stated
31% HNO_3	865 mS/cm	Rarely Stated

3.2 Principle of Toroidal Cell Operation

The ES-5 electrodeless conductivity sensor employs two toroidally wound coils in close proximity to each other. An alternating current is applied to one of the coils, generating an electric field in the solution being measured. The second toroidal coil acts as a receiver to detect the small current formed from ion movement in the conducting loop of solution, which is proportional to the solution Conductivity. The entire assembly is encapsulated in CPVC, so no metallic contact with the solution occurs.

3.3 Advantages of the Electrodeless Conductivity System

The design of the electrodeless conductivity system eliminates any form of polarization, so accurate readings in all types of solutions are possible. Electrode contamination, which can lead to erroneous readings, is also not a problem. Since the conduction process occurs in a volume of solution, any fouling (such as a coating of oil formed on the probe) merely reduces the conductivity reading by the insignificant amount of volume reduction.

The CPVC encapsulation prevents any solution to metallic contact, thereby eliminating the possibility of gas formations at the electrode surface, which can occur using the more conventional contacting type conductivity systems.

The electrodeless conductivity probe measures up to the highest known conductivity (approximately 1 S/cm) with great accuracy.

3.4 Temperature effects

Conductivity has a substantial dependence on temperature. This dependence is usually expressed as percent/°C at 25°C. Ultrapure water has the largest dependence on temperature, at 5.2%/°C. Ionic salts has a dependence of about 2%/°C, with acids, alkalis, and concentrated salts solutions are around 1.5%/°C. Temperature variation causes frequent problems with conductivity measurements when the solution under testing has a rapid varying temperature. The change in conductivity is instantaneous, since it is an electrical measurement. The thermistor, however, has a response time of 15 seconds to several minutes. A good rule of thumb is to allow 5 times the time it takes for the thermistor to respond to allow the reading to stabilize. Any sudden dips or peaks should be ignored during this time.

4 Installation

4.1 Electrode Connections

The ES-5 is a two-wire, loop-powered sensor so there are only two connections plus an optional ground. Figure 1 shows the electrical connections.

1. Connect the white wire of the electrode to the signal input.
2. Connect the black wire of the electrode to 24 VDC.
3. Connect the bare silver ground wire of the electrode to ground. It can be left unconnected in most applications.

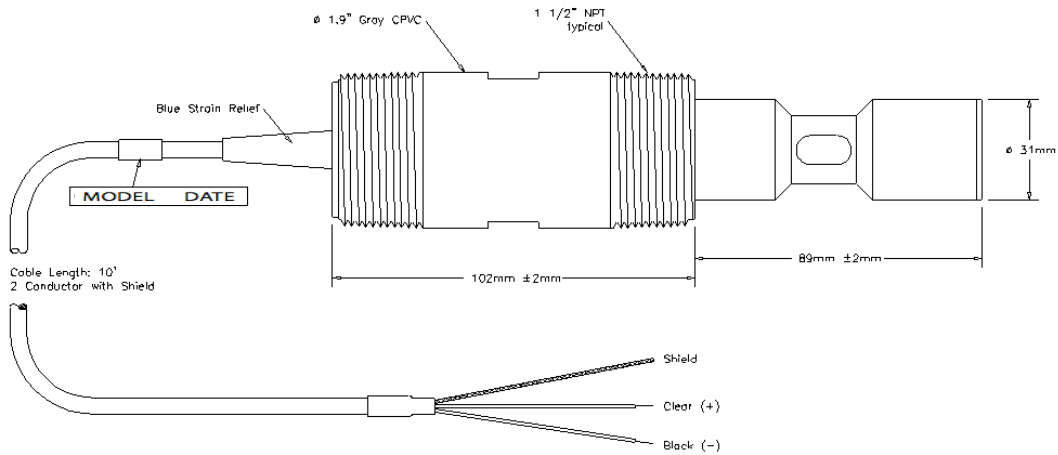

Figure 1 - Electrical Connections of the ES-5. The clear wire connects to the 24 VDC of the current loop and the black wire connects to the signal input.

4.2 Positioning of the Sensor

The ES-5 comes with two 1.5" MNPT threads—on the front and back end. In tank applications the ES-5 mounts on to the end of a submersion arm that terminates via the rear 1.5" FNPT thread. AquaMetrix sells the STC60L submersion arm for this purpose. For mounting in a pipe a union tee is required. Because of the insertion depth only pipes with a pipe diameter greater than 4" may be used.

It's very important that the sensor does not contact the walls of the container or pipe as that will cause a decrease in the observed conductivity reading.

5 Operation

5.1 Calibration

1. Place electrode in the air. Calibrate the meter to read 0.00 by turning the setscrew on the zero control of the controller.
2. Prepare a 10, 95.5, or 500 mS/cm conductivity standard depending on the measurement range of the toroidal cell connected to the controller. To make a 10 mS standard, dissolve 11.4 g KCl (potassium chloride) in 2 liter of distilled water. To make a 95.5 mS standard, dissolve 200 g KNO₃ (potassium nitrate) in 2 liter of distilled water. To make a 500 mS/cm standard, dissolve 200 ml of concentrated HNO₃ (nitric acid) in 2 liters of distilled water.
3. Place the electrode into the selected conductivity standard placed in a 2-liter beaker. Do not stir. Do not allow the electrode to be in contact with the walls or the bottom of the beaker. The electrode should react immediately and show a rapid increase in the reading. After 60 seconds, calibrate the meter to read the value of the standard.

5.2 Sample Requirements

For maximum accuracy and efficiency, the conductivity probe must meet the following requirements: - The sample in the cell must be representative of the whole solution.

1. The solution must circulate continuously through the cell.

2. The flow velocity must not be so high as to cause cavitations.
3. The position/orientation of the cell must not trap air bubbles near the electrode area.
4. Sediment must not accumulate within the electrode area.
5. For immersion applications, the water must be continuously agitated.
6. For in-line applications, 100mm is the minimum size pipe the cell may be installed in. The probe has a 1.5-inch MNPT fitting for screwing into a pipe.
7. Keep the overall length of cabling away from power wires.

5.3 Measurement

After immersion or mounting the electrode, read the conductivity value in mS directly from the controller display.

5.4 Cleaning Methods

For most applications, hot water mixed with domestic cleaning detergent can be used for cleaning.

1. For lime and other scaling compounds, clean with a 5-10% solution of hydrochloric acid.
2. For solutions containing organic fouling agents (fats, oils, etc.), clean probe with acetone or alcohol.
3. For algae and bacteria containing solutions, clean the probe with a bleach solution and a soft brush.