



PV210

Druck low pressure and vacuum hand pump

The PV210 is a lightweight, yet rugged and durable, low pressure and vacuum hand pump offering exceptional fine control. Thermally insulated to eliminate hand held temperature effects and supplied with a built-in pressure relief valve to protect the test instrument, this pump was truly designed with the requirements of low pressure calibrations in mind.

- Dual source of pneumatic pressure and vacuum
- Finger-tight quick fit connectors
- Extremely low pressures generated by using the fine adjust vernier alone
- Built-in pressure relief valve for setting maximum output pressure
- Fine control needle valve for pressure release

Features

- Pneumatic pressures to 1250 in H₂O/45 psi
- Vacuum to -27 in Hg
- Precise fine control to 0.01 in H₂O
- Thermally insulated to eliminate temperature effects

PV210 specifications

General

Pressure range

0 to 1250 in H₂O, 0 to 45 psi

Vacuum Range

0 to 27 in Hg

Relief valve adjustment

20 in H₂O to maximum pressure

Materials

Bright nickel-plated brass, anodized aluminum, phosphor bronze, nitrile seals, nylon hose

Dimensions (h x w)

6.7 in to 1.8 in diameter

Weight

1 lb

Ordering information

PV210

Hand pump, two flexible, 3 ft long by 1/8 in diameter, nylon hoses with 1/4 in NPT female adaptors

PV210-HA

Hand pump in carrying case with two flexible, 3 ft long by 1/8 in diameter nylon hoses with 1/4 in NPT female adaptors and accessories

IAS-A110

Service kit

Supporting services (order as separate items)

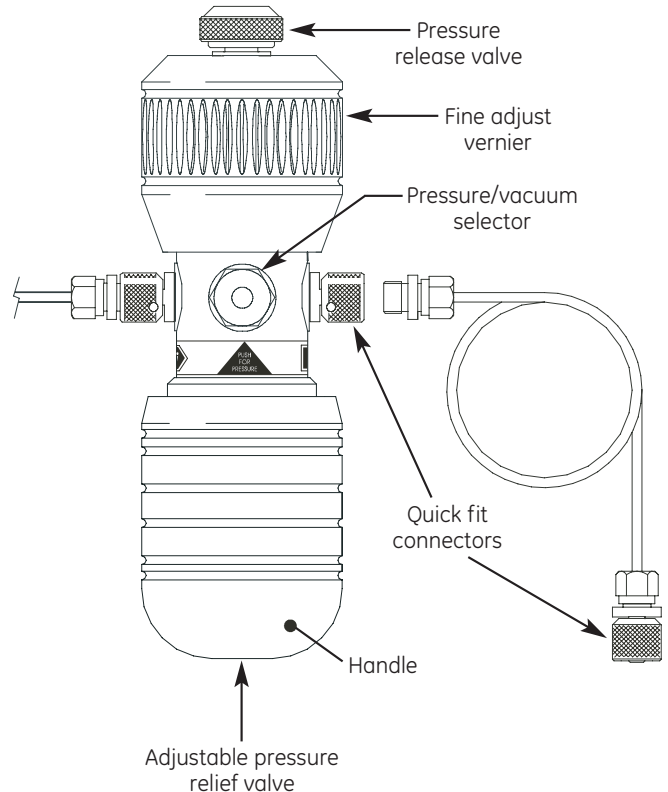

Supporting services

Our highly trained staff can support you, no matter where you are in the world. We can provide training, nationally accredited calibration - both initially and at periodic intervals - extended warranty terms, maintenance and even rental of portable or laboratory calibrators. Further details can be found at druck.com