



Oxygen Analyzer
DF-310E

OPERATOR MANUAL

Copyright 2011 by Servomex Corporation

No part of this publication may be reproduced, stored in a retrieval system or transmitted in any form, or by any means including electronic, mechanical, photocopying, recording or otherwise without prior written permission of Servomex Corporation.

Stablex™, Bi-Strata™ and are trademarks of Servomex Corporation. VCR® is a registered trademark of the Cajon Company.

**DF-310E Operator Manual
Firmware v2.57
Manual Version 102511**

Your Process Oxygen Analyzer has been designed, manufactured and is supported under ISO-9001 controls, thus helping to insure the highest possible standards of quality.

Every analyzer that Servomex manufactures is tested and operated on a variety of gas concentrations to insure that it functions properly when you receive it.

The certificate of calibration assures your analyzer has been calibrated on gases that are traceable to NIST standards. With proper maintenance, your analyzer should remain calibrated for years.

For a fast and successful startup, please read this manual carefully. There are important cautions and a number of helpful hints to help you to optimize the operation of your analyzer.

For more information or if you have questions, please do not hesitate to go to our website at Servomex.com, or contact your local Servomex Business Center as found on the back cover of this manual.

Read Me First...

Unpacking Procedure

Follow the procedure below to unpack your Process Oxygen Analyzer.

1. Examine the condition of the packaging and its contents. If any damage is apparent, immediately notify the carrier and Servomex. Do not proceed with the installation.
2. Check the contents against the packing slip to make sure the shipment is complete. Unattached equipment may be shipped with the analyzer in supplemental packaging. Shortages should be reported to Servomex immediately.
3. All analyzers are shipped with the following:

| Item | Servomex Part Number |
|---|----------------------|
| One bottle of Hummingbird Brand Electrolyte Blue | Electrolyte Blue |
| One bottle of Hummingbird Brand Replenishment Solution | 210515 |
| Power Cord with 115VAC connector NOTE - No power cord is supplied with 220 VAC or DC powered units | 210408 |
| Instruction Manual | 210450 |

4. Open the analyzer door, remove any shipping materials and verify that nothing has come loose during transit.
5. Save the original container in the event you may need to ship the analyzer to another location or back to the factory (see Shipping in the Service section).

Installation and Maintenance

The *DF-310E* Process Oxygen Analyzer will provide years of accurate and dependable service if it is set up, operated and maintained properly. It is essential to make a careful and complete installation as outlined in the *Installation and Setup* section of this manual.

Thank You

Thank you for selecting the model *DF-310E* Process Oxygen Analyzer. Servomex designs, manufactures, exhaustively tests, and supports every analyzer under ISO-9001 control. You should expect every Servomex analyzer to arrive in good working order and, with proper maintenance, provide years of trouble-free service.

1 Table of Contents

| | | |
|----------|---|-----------|
| 1 | Table of Contents | 1 |
| 1.1 | Table of Figures | 4 |
| 2 | Cautions | 7 |
| 2.1 | Symbols and Explanations | 7 |
| 2.2 | Important Warnings | 7 |
| 3 | Specifications | 9 |
| 4 | Installation and Setup | 13 |
| 4.1 | Adding Electrolyte | 14 |
| 4.2 | Sample Gas Connections | 15 |
| 4.2.1 | Purging the Analyzer | 15 |
| 4.3 | Electrical Power Connections | 16 |
| 4.3.1 | AC Input Voltage (100-240 VAC) | 16 |
| 4.3.2 | DC Input Voltage (24 VDC) | 16 |
| 4.4 | Power Control | 16 |
| 4.4.1 | Startup Process | 17 |
| 4.4.2 | Powering Down | 17 |
| 4.5 | Standard Outputs..... | 17 |
| 5 | Options | 19 |
| 5.1 | Pump | 19 |
| 5.1.1 | Pump Control..... | 19 |
| 5.2 | Battery Power..... | 19 |
| 5.3 | Low Flow Alarm..... | 20 |
| 5.4 | Flow Control Valve..... | 21 |
| 5.5 | Filter..... | 21 |
| 5.6 | Pressure Regulator | 21 |
| 5.7 | Combined Filter/Pressure Regulator | 23 |
| 5.8 | Stainless Steel Outlet Tubing | 24 |
| 5.9 | Key Lock..... | 24 |
| 5.10 | 4-20mA Analog Output..... | 25 |
| 5.10.1 | 2-20mA Analog Output | 25 |
| 5.11 | Relays | 25 |
| 5.12 | Communication Port – RS232/485..... | 26 |
| 5.13 | Expanded Range Scale | 26 |
| 5.14 | Panel Mount | 26 |
| 5.15 | Rack Mount | 28 |
| 5.16 | Dual Rack Mount | 28 |
| 5.17 | Remote Display | 28 |
| 5.18 | Case Purge..... | 30 |
| 6 | Sample Gas Preparation and Delivery | 33 |
| 6.1 | The STAB-EL Acid Gas System | 33 |
| 6.2 | Sample Gas Scale Factor..... | 34 |
| 6.3 | Sample Flow Rate and Pressure | 35 |
| 6.3.1 | Flow Rate Effects on Sensor Performance | 36 |
| 6.3.2 | Checking for Plumbing Leaks using Flow Rate Effects | 36 |
| 6.3.3 | Background Gas Effects on Indicated Flow Rate | 36 |
| 6.3.4 | Regulator Requirements | 36 |

| | | |
|----------|---|-----------|
| 6.3.5 | Pressure Regulator Purge | 37 |
| 6.3.6 | Pressure Effects on Sensor Performance | 37 |
| 6.3.7 | Sample Outlet Backpressure Effects | 38 |
| 6.4 | Sample Gas Compatibility | 38 |
| 6.4.1 | Condensation | 38 |
| 6.4.2 | Gas Solubility in Aqueous KOH Solution | 39 |
| 6.4.3 | Reactivity with KOH Electrolyte | 39 |
| 6.4.4 | Flammable Sample Gas | 39 |
| 6.4.5 | Trace acids in the sample gas | 39 |
| 6.4.6 | Sample Gas Temperature | 40 |
| 6.4.7 | Protecting the Analyzer from Process Upsets | 40 |
| 6.5 | Calibration Gas Considerations | 40 |
| 6.5.1 | Calibration Standards | 40 |
| 6.5.2 | Calibration Cylinder Regulators | 41 |
| 6.5.3 | Purge Procedure | 41 |
| 6.5.4 | Sample Gas Delivery and Vent Pressure during Calibration | 41 |
| 6.5.5 | Background Gas Effects on Calibration | 42 |
| 7 | Connecting to External Devices | 43 |
| 7.1 | The Comm Port | 43 |
| 7.2 | Relay Ports | 44 |
| 7.3 | Analog Outputs | 45 |
| 7.3.1 | Analog Voltage Output | 45 |
| 7.3.2 | 4-20mA Output | 46 |
| 7.3.3 | Alignment Procedure for Analog Voltage and Current Loop Outputs | 47 |
| 7.4 | Remote Controls | 47 |
| 7.4.1 | Remote Sensor Control – J6 Connector | 47 |
| 7.4.2 | Remote Pump Control – J6 Connector | 48 |
| 7.5 | Remote Sensor Installations | 49 |
| 7.5.1 | Sensor on Remote Bracket with Optional Pump | 50 |
| 7.5.2 | Sensor in NEMA 4 Enclosure | 51 |
| 7.5.3 | Sensor in NEMA 7 Enclosure | 52 |
| 7.5.4 | Temperature Control in R4/R7 Enclosures | 53 |
| 7.5.5 | Remote Sensor Connections – Connector J7 | 54 |
| 7.5.6 | Z-Purge Protection on R4 Enclosure | 56 |
| 8 | User Interface | 59 |
| 8.1 | The Data Display Screen | 59 |
| 8.2 | Main Menu | 63 |
| 8.2.1 | Keypad Operation | 64 |
| 8.3 | Controls Menu | 65 |
| 8.3.1 | Pump | 65 |
| 8.3.2 | Sensor Polarization | 66 |
| 8.3.3 | SensOFF Relay | 66 |
| 8.3.4 | P(o)w(e)r UP | 67 |
| 8.3.5 | ESC | 67 |
| 8.4 | Set-Up Menu | 67 |
| 8.4.1 | Alarms | 68 |
| 8.4.2 | Analog Outputs | 70 |
| 8.4.3 | Comm Port | 73 |
| 8.4.4 | Gas Scale Factor | 74 |
| 8.4.5 | Display Setup | 74 |
| 8.4.6 | Clock | 75 |
| 8.5 | The Password Menu | 76 |
| 8.6 | Maintenance | 77 |
| 8.6.1 | Replenish Solution Reminder | 78 |
| 8.6.2 | Oxygen Calibration | 79 |
| 8.6.3 | Diagnostics | 86 |

| | | |
|-----------|---|------------|
| 9 | Troubleshooting and Calibration..... | 93 |
| 9.1 | Return Material Authorization Number | 93 |
| 9.2 | Maintenance | 93 |
| 9.2.1 | Calibration | 93 |
| 9.2.2 | Storage Conditions | 94 |
| 9.2.3 | Sensor Maintenance..... | 94 |
| 9.2.4 | Procedure for Adding Replenishment Solution to the Sensor | 95 |
| 9.3 | Replaceable Parts List | 96 |
| 9.4 | Troubleshooting | 97 |
| 9.4.1 | Sample System Leak Test (Low Flow Sensitivity)..... | 97 |
| 9.4.2 | Basic Troubleshooting | 98 |
| 9.4.3 | Fuse Replacement..... | 100 |
| 9.5 | Shipping | 103 |
| 10 | Theory of Operation..... | 105 |
| 10.1 | The Oxygen Sensor | 105 |
| 10.2 | The Electrolyte Conditioning System..... | 106 |
| 11 | Safety | 107 |
| 11.1 | Electrolyte Solution MSDS | 109 |
| 11.2 | Replenishment Solution MSDS..... | 115 |
| 12 | Warranty | 119 |
| 13 | Index | 121 |

1.1 Table of Figures

| | |
|---|----|
| Figure 1: DF-310E Oxygen Analyzer | 12 |
| Figure 2: Major Internal Components | 13 |
| Figure 3: Quick Disconnect Fitting at Flowmeter | 15 |
| Figure 4: DC Power Connector – J3 | 16 |
| Figure 5: Data Display Screen | 17 |
| Figure 6: Rear Panel..... | 18 |
| Figure 7: Plumbing Configuration Options..... | 22 |
| Figure 8: Filter Installation..... | 23 |
| Figure 9: Regulator Installation..... | 24 |
| Figure 10: Combined Filter/Regulator Assembly | 25 |
| Figure 11: Panel Mount Configuration | 27 |
| Figure 12: Cutout Dimensions for Panel Mount | 27 |
| Figure 13: Rack Mount | 28 |
| Figure 14: Dual Rack Mount..... | 28 |
| Figure 15: Remote Display | 29 |
| Figure 16: Remote Display Wiring | 30 |
| Figure 17: Case Purge Option | 31 |
| Figure 18: J7/J8 Connector Wiring | 43 |
| Figure 19: J1/J2 Connector Wiring | 44 |
| Figure 20: J5/J6 Connector Wiring | 46 |
| Figure 21: Analog Voltage Output and 4-20mA Adjustments | 47 |
| Figure 22: J5/J6 Connector Wiring | 48 |
| Figure 23: J3/J4 Connector Wiring | 49 |
| Figure 24: Remote Sensor with Optional Pump..... | 50 |
| Figure 25: Remote Sensor Mounted in NEMA 4 Enclosure | 51 |
| Figure 26: Remote Sensor Mounted in NEMA 7 Enclosure | 52 |
| Figure 27: NEMA 7 Enclosure Mounting Dimensions | 53 |
| Figure 28: Temperature Control in R7 Enclosure | 54 |
| Figure 29: Remote Sensor Connector – J7..... | 55 |
| Figure 30: Remote Sensor/Pump Wiring Diagram | 55 |
| Figure 31: Z-Purge Protection on R4 Sensor Enclosure..... | 56 |
| Figure 32: Data Display and Keypad | 59 |
| Figure 33: Main Menu | 63 |
| Figure 34: Controls Menu | 65 |
| Figure 35: Sensor Shut-off Warning | 66 |
| Figure 36: Setup Menu..... | 67 |
| Figure 37: Alarm Setup Menu..... | 68 |
| Figure 38: Oxygen Alarm Menu | 68 |
| Figure 39: Oxygen Alarm Setup Screen (Alarm not used) | 68 |
| Figure 40: Oxygen Alarm Setup Screen (Alarm used)..... | 69 |
| Figure 41: Recorder Output Setup Menu | 71 |
| Figure 42: Recorder Output Setup Error | 72 |
| Figure 43: Comm Port Setup Menu | 74 |
| Figure 44: Display Setup..... | 75 |
| Figure 45: Clock Setup Screen..... | 76 |
| Figure 46: Password Menu..... | 76 |
| Figure 47: Password Entry Screen | 77 |
| Figure 48: Maintenance Menu | 78 |
| Figure 49: Replenishment Solution Reminder | 78 |
| Figure 50: Oxygen Calibration Menu | 79 |
| Figure 51: Gas Scale Factor | 80 |
| Figure 52: Gas Scale Factor Menu (Cont'd) | 80 |
| Figure 53: Span Check Menu..... | 83 |
| Figure 54: Calibration Convergence Screen..... | 84 |
| Figure 55: Completed Oxygen Calibration Menu | 85 |
| Figure 56: Diagnostics Menu | 86 |

| | |
|--|-----|
| Figure 57: Sensor Zero Menu..... | 87 |
| Figure 58: Zero Cal Warning Screen..... | 88 |
| Figure 59: Zero Cal Screen | 88 |
| Figure 60: Zero Cal Not Stable | 89 |
| Figure 61: Test Output Screen..... | 89 |
| Figure 62: Test Relay Screen | 90 |
| Figure 63: Memory Test Screen | 90 |
| Figure 64: EXT Functions | 91 |
| Figure 65: Fuse Locations for DC Power Supply and Battery Backup | 102 |
| Figure 66: Printed Circuit Board Assembly | 102 |
| Figure 67: Schematic of Servomex Oxygen Sensor | 105 |

2 Cautions

There are a number of warnings and cautions that must be observed to avoid damage to the analyzer as well to insure the safety of its users. The analyzer must be operated in a manner specified in this manual. Servomex cannot be responsible for direct or consequential damages that result from installing or operating the analyzer in a manner not described in this manual. Importantly, the analyzer has been designed for use with inert, non-toxic, non-combustible sample gases only. Servomex cannot be responsible for direct or consequential damages that result from using the analyzer with these gases.

2.1 Symbols and Explanations

Following is a list of the various symbols used throughout this manual and their definitions.

CAUTION



This symbol alerts the user to the presence of physically hazardous conditions that may be dangerous to individuals or equipment.

NOTE



This symbol alerts the user to the presence of important operations and/or maintenance information.

DANGER



This symbol alerts the user to the presence of caustic liquid. Refer to the MSDS at the back of the manual for handling instructions.

2.2 Important Warnings

CAUTION



Do not setup or operate the Oxygen Analyzer without a complete understanding of the instructions in this manual. Do not connect this Analyzer to a power source until all signal and plumbing connections are made.

CAUTION



This analyzer must be operated in a manner consistent with its intended use and as specified in this manual.

DANGER



The electrolyte is a caustic solution. Review the Material Safety Data Sheet (MSDS) before handling the electrolyte solution.

The sensor is shipped dry and must be charged with electrolyte before it is operated.

CAUTION



Over-pressurizing the sensor can result in permanent damage to the sensor. Limit the backpressure to the analyzer to ± 1 psig.

Be sure the downstream isolation valve (if so equipped) is toggled open **before** gas flow is started.

CAUTION



DO NOT SHIP THE ANALYZER WITH ELECTROLYTE – THOROUGHLY DRAIN AND RINSE SENSOR BEFORE SHIPPING

EMI DISCLAIMER



This Analyzer generates and uses small amounts of radio frequency energy. There is no guarantee that interference to radio or television signals will not occur in a particular installation. If interference is experienced, turn-off the analyzer. If the interference disappears, try one or more of the following methods to correct the problem:

Reorient the receiving antenna.

Move the instrument with respect to the receiver.

Place the analyzer and receiver on different AC circuits.

NOTE



For best performance at initial start or anytime the electrolyte is changed, it is important to allow the sensor to sit with electrolyte in it for 60 minutes *before* the gas is allowed to flow through the sensor.

3 Specifications

PERFORMANCE

ACCURACY

Standard Resolution: Greater of $\pm 3\%$ of reading (not to exceed 1% of range for % Analyzers) or 0.5% of range.

High Resolution: Greater of $\pm 3\%$ of reading (not to exceed 1% of range for % range Analyzers) or $\pm 0.02\%$ of range (except ranges less than or equal to 100 ppm, $\pm 3\%$ of reading or $\pm 0.05\%$ of range).

RESPONSE TIME

Typically less than 10 seconds to read 90% of a step change. Equilibrium time depends on the specific conditions.

OXYGEN SENSITIVITY

3 ppb (310E-H0050M Model only)

LOW DETECTION LIMIT

3 ppb (310E-H0050M Model only)

RESOLUTION

| Model Number | Range | Auto Scale A* | Display | Auto Scale B* | Display |
|--------------|-------------|---------------|---------|---------------|---------|
| S00050 | 0-50 ppm | | | 0-50 ppm | XX.XX |
| S00100 | 0-100 ppm | | | 0-100 ppm | XXX.X |
| S00500 | 0-500 ppm | | | 0-500 ppm | XXX.X |
| S01000 | 0-1000 ppm | | | 0-1000 ppm | XXXX. |
| S05000 | 0-5000 ppm | | | 0-5000 ppm | XXXX. |
| S10000 | 0-10000 ppm | | | 0-10000 ppm | XXXXX |
| S000P5 | 0-5 % | | | 0-5 % | X.XX |
| S00P10 | 0-10 % | | | 0-10 % | XX.XX |
| S00P25 | 0-25 % | | | 0-25 % | XX.X |
| H0050M | 0-50 ppm | 0 - 5 | X.XXX | 5 - 50 | XX.XX |
| H00100 | 0-100 ppm | 0 - 10 | XX.XX | 10 - 100 | XXX.X |
| H00500 | 0-500 ppm | 0 - 50 | XX.X | 50 - 500 | XXX. |
| H01000 | 0-1000 ppm | 0 - 100 | XXX.X | 100 - 1000 | XXXX. |
| H05000 | 0-5000 ppm | 0 - 500 | XXX. | 500 - 5000 | XXXX. |
| H10000 | 0-10000 ppm | 0 - 1000 | XXXX. | 1000 - 10000 | XXXXX |
| H000P5 | 0-5 % | 0 - 0.5 | .XXX% | 0.5 - 5 | X.XX |
| H00P10 | 0-10 % | 0 - 1 | X.XXX% | 1 - 10 | XX.XX |
| H00P25 | 0-25% | 0 - 2.5 | X.XX% | 2.5 - 25 | XX.X |

*Scale A applies to High Resolution models only. Scale B extends down to 0 ppm or 0% on Standard Resolution models.

OVERALL OPERATING TEMPERATURE RANGE

Gas sample: 32°F to 113°F (0°C to 45°C)
Sensor Temperature: 32°F to 113°F (0°C to 45°C)
Electronics Temperature:
w/sensor in enclosure: 32°F to 113°F (0°C to 45°C)
w/remote sensor: 32°F to 122°F (0°C to 50°C)

STORAGE TEMPERATURE

Not to exceed 113°F (45°C)

SENSOR TYPE

Non-depleting Coulometric

SENSOR WARRANTY

Five (5) years (limited)

ELECTRICAL, ALARMS & DISPLAY

ELECTRONICS

Microprocessor-based

DISPLAY

1.3 in (33mm) by 2.6 in (66mm) LCD graphics with backlighting

ALARMS

Audible and Displayed. Up to 7 optional alarms comprised of 4 oxygen, temperature, low flow, and electrolyte condition.

STATUS CONDITIONS

Sensor Off, Check Fluid, Expanded Range (optional), In-Calibration status conditions can be assigned to relays (optional).

OUTPUT

Software scalable, jumper selectable 0-5 or 0-10 VDC analog output.

Minimum load resistance is 1K.

Fully isolated 4-20 mA output. Maximum loop resistance is 1K Ohms. (29-33 VDC loop compliance voltage provided)

ALARM RELAYS

Up to four, rated at 0.3 A, 30 VDC under resistive load. Set points independently adjustable. Contacts failsafe to alarm condition upon loss of power. Not designed to switch AC power.

POWER REQUIREMENTS

100 – 240 VAC (auto-switching), 1.3A, 50/60 Hz or

24 VDC (-2/+4VDC), 1A, 25 Watts; Optional Sample Pump 6W additional

EMI SENSITIVITY

Meets CISPR – 11(90) Class B Group 1 Standard

CONSTRUCTION

WEIGHT

9.5 lbs. (4.3kg) Standard Model (no options)

DIMENSIONS - Overall

8.375"w x 8.0"h x 8.5"d (21.3 cm x 20.3 cm x 21.6 cm) (with handle and gas fittings)

CE Approved

CSA Approved

GAS SAMPLE CONDITIONS

GAS CONNECTIONS

1/8" Compression inlet and outlet Standard

1/4" Metal-face-seal inlet (Optional)

SAMPLE INLET PRESSURE

0.2 psig to 1.0 psig; 5 - 15 psig with VCR welded sample inlet (orifice restricted)

SAMPLE FLOW RATE

1.0 to 2.0 scfh standard operating limits

GAS COMPATIBILITY

Standard Sensor: All inert and passive gases, including N₂, H₂, CO, Ar, freons, hydrocarbons, etc.

STAB-EL Sensor: Limited tolerance to gas compositions containing "acid" gases such as CO₂, H₂S, Cl₂, NO_x, SO₂, HCl, etc.

GAS SAMPLE MOISTURE CONTENT

No limit (avoid condensation)

OIL/SOLVENT MIST

<0.03 mg/L Standard limit

>0.03 mg/L Use filter

SOLID PARTICLES

<0.01 mg/L Standard limit, Use filter if >0.01 mg/L

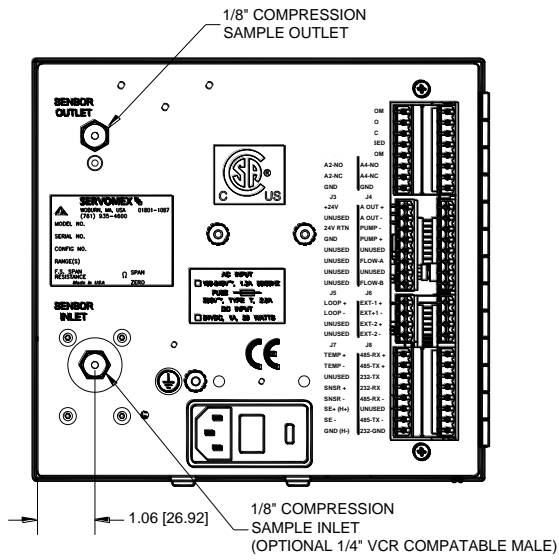
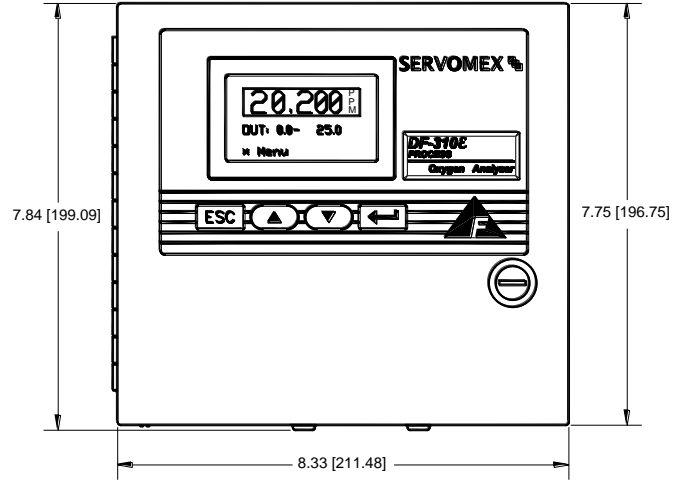
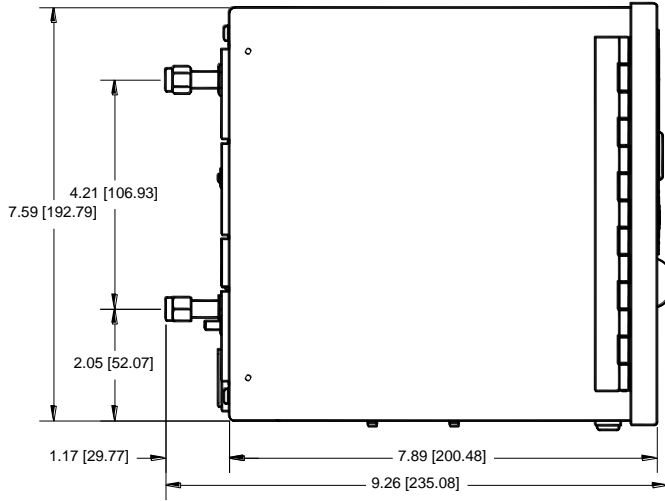

Figure 1: DF-310E Oxygen Analyzer

4 Installation and Setup

This procedure describes installation of the analyzer without options and with the voltage output set to 0-10 VDC. Options may affect the setup procedure described in this section. If your analyzer is equipped with options, refer to the appropriate section to determine changes to the setup.

NOTE



The screens shown in this manual have values that may not match the actual values displayed during your setup.

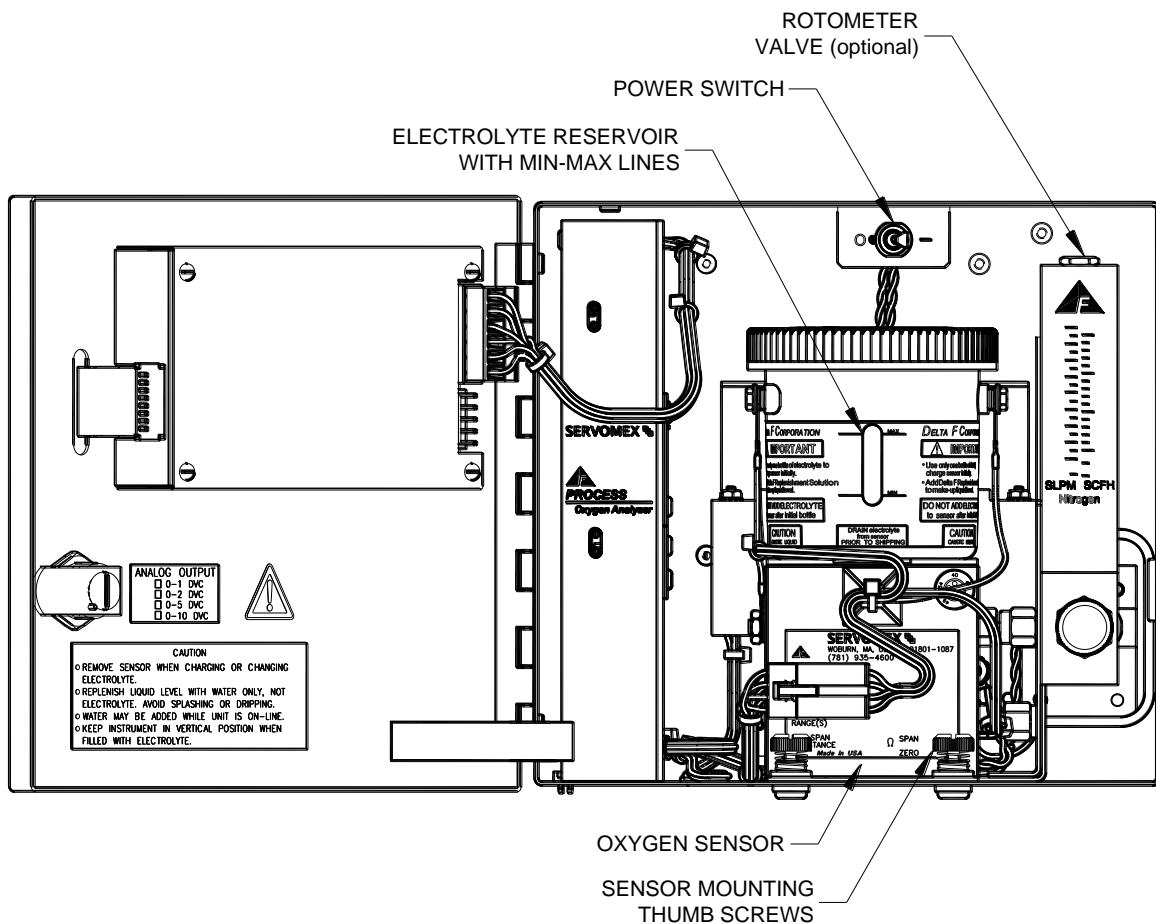

Figure 2: Major Internal Components

4.1 Adding Electrolyte

DANGER



The electrolyte is a caustic solution. Review the Material Safety Data Sheet (MSDS) before handling the electrolyte solution.

NOTE



The sensor is shipped dry and must be charged with electrolyte before it is operated.

NOTE



Use only Hummingbird \mathcal{E} -lectrolyte Blue for the DF-310 \mathcal{E} Oxygen Analyzer. Failure to do so will void warranty. Install one bottle.

NOTE



Do not apply power before adding electrolyte and thoroughly purging sample line.

Remove the sensor as follows:

- 1) Using a ½ inch open-end wrench, remove the inlet bulkhead retainer nut from the inlet bulkhead fitting at the back of the analyzer. Do not remove the four small socket screws. (The VCR inlet option requires a ¾ inch wrench) If equipped with the Stainless Steel Outlet Line option disconnect using a wrench on the retaining nut on the rear of the cabinet.
- 2) Inside the enclosure, disconnect the 9-pin sensor connector located near the front of the sensor.
- 3) Unscrew both sensor-mounting thumbscrews at the front of the sensor-mounting bracket.
- 4) Pull the sensor assembly forward a few inches and disconnect the "quick-disconnect" fitting at the top of the flowmeter (for standard downstream sensor configuration) by pushing both halves of the fitting together and rotating one to the release position. See Figure 3.
- 5) Remove the sensor assembly from the instrument.
- 6) Unscrew the cap from the electrolyte reservoir and add the entire contents of *one* bottle of \mathcal{E} -lectrolyte Blue to the sensor.
- 7) Replace the cap and hand-tighten securely.
- 8) Reinstall the sensor by repeating steps 1 through 4 in reverse order.
- 9) Allow the sensor to sit with electrolyte in it for approximately 60 minutes before flowing gas through the analyzer.

NOTE



The flats on the inlet bulkhead fitting are oriented to seat in an anti-torque plate on the inside back of the enclosure. When re-installing the Sensor Assembly, be sure the flats on the bulkhead fitting properly seat in the slot of the anti-torque plate before replacing the retainer nut.

NOTE



For best performance at initial start or anytime the electrolyte is changed, it is important to allow the sensor to sit with electrolyte in it for 60 minutes *before* the gas is allowed to flow through the sensor.

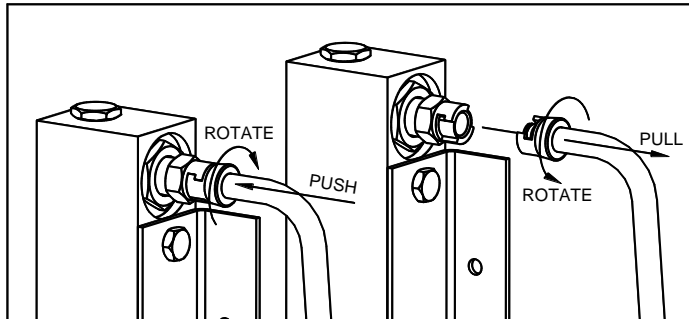

Figure 3: Quick Disconnect Fitting at Flowmeter

4.2 Sample Gas Connections

The sample gas inlet and outlet lines at the back of the instrument have stainless steel 1/8th inch compression bulkhead fittings (unless equipped with the optional 1/4 inch VCR inlet). Before connecting any gas line to the analyzer, fully install the supplied gas nut and compression ferrule on your tubing. Connect the inlet and outlet lines to the bulkhead fittings at the back of the analyzer. A backup wrench is not needed since anti-torque plates inside the cabinet secure the bulkhead fittings. Do not over-tighten the fittings.

4.2.1 Purging the Analyzer

Supply the analyzer with an N₂ sample that is as low in O₂ as possible. If the analyzer outlet is at atmospheric pressure, a regulator can be used to set the flow rate to 1.0 standard cubic feet per hour (scfh) without danger of over-pressurizing the sensor. The back-pressure on the instrument should not exceed ± 1.0 psig. If the installation requires long (> 6 feet) tubing runs (or has many bends or fittings) downstream of the analyzer, the resulting back-pressure may impose a pressure at the sensor that exceeds specifications. If this is the case, use larger outlet tubing (1/4-inch) and/or reduce the complexity of the outlet gas line. See page 30 for additional information on gas sample delivery.

NOTE



Over-pressurizing the sensor can result in permanent damage to the sensor. Limit the backpressure to the analyzer to ± 1 psig.

NOTE



Allow gas with very little oxygen to flow through the analyzer for approximately 60 minutes before powering up.

4.3 Electrical Power Connections

4.3.1 AC Input Voltage (100-240 VAC)

Make sure the power switch is in the OFF position. Plug the supplied power cord into the connector on the rear of the analyzer. See Figure 6. The power supply is auto-switching which means it will run properly on an input voltage between 100 VAC and 240 VAC.

4.3.2 DC Input Voltage (24 VDC)

Make sure the power switch is in the OFF position. Using 20 gauge wire, attach the power supply leads to the power connector J3 on the rear of the instrument. Pin 1 (top) is positive (+24V) and Pin 3 is negative (24V RTN). See Figure 4 below.

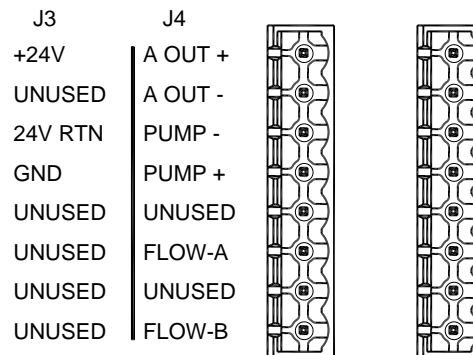

Figure 4: DC Power Connector – J3

4.4 Power Control

AC Powered Units - Open the front door, locate the power switch and turn it on. See Figure 2.

DC Powered Units - Turn on the remote 24 VDC power source, open the front door, locate the power switch and turn it on. See Figure 2.

4.4.1 Startup Process

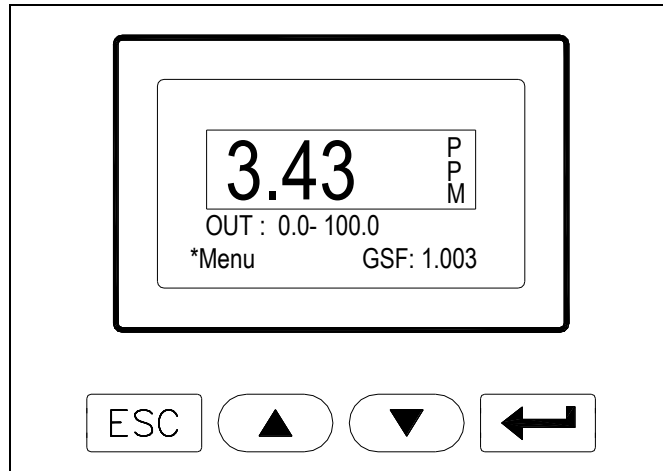

Figure 5: Data Display Screen

NOTE



For best performance at initial start or anytime the electrolyte is changed, it is important to allow the sensor to sit with electrolyte in it for 60 minutes *before* the gas is allowed to flow through the sensor.

After power up, the analyzer will undergo a series of Diagnostic Procedures. After approximately 5 seconds, the Servomex Corporation logo is displayed. After 30 seconds, a WAIT message appears for 1.5 minutes. A display then appears that is similar to Figure 5 (values shown are only representative). The analyzer may display OVER RANGE for the first couple of minutes. This is normal even if the actual O₂ concentration is within the range of the analyzer.

It should take less than 5 minutes for the analyzer to come on scale. The concentration of oxygen is shown in percent (%) or parts per million (ppm) and will slowly approach the current oxygen level. NOTE: If it takes longer than 30 minutes to come on scale the sensor polarization voltage will automatically be turned off. (See page 66 for additional information)

4.4.2 Powering Down

Locate the power switch inside the front door and turn it off. See Figure 2.

4.5 Standard Outputs

An output signal indicating oxygen concentration can be sent to other instruments by using the optional fully-isolated 4-20 mA output or the standard non-isolated 0-10 VDC analog voltage output at the back of the analyzer. The analyzer is delivered with the required mating connectors which are keyed to prevent accidental interchange. The analog output connections are made through the Port J4 and J5 on the rear panel as shown in Figure 6.

The analog voltage output is connected to pins J4-1 (AOUT+) and J4-2 (AOUT-). The full scale analog output is set by a jumper as described on page 45.

See page 25 for information on the optional 4-20mA output.

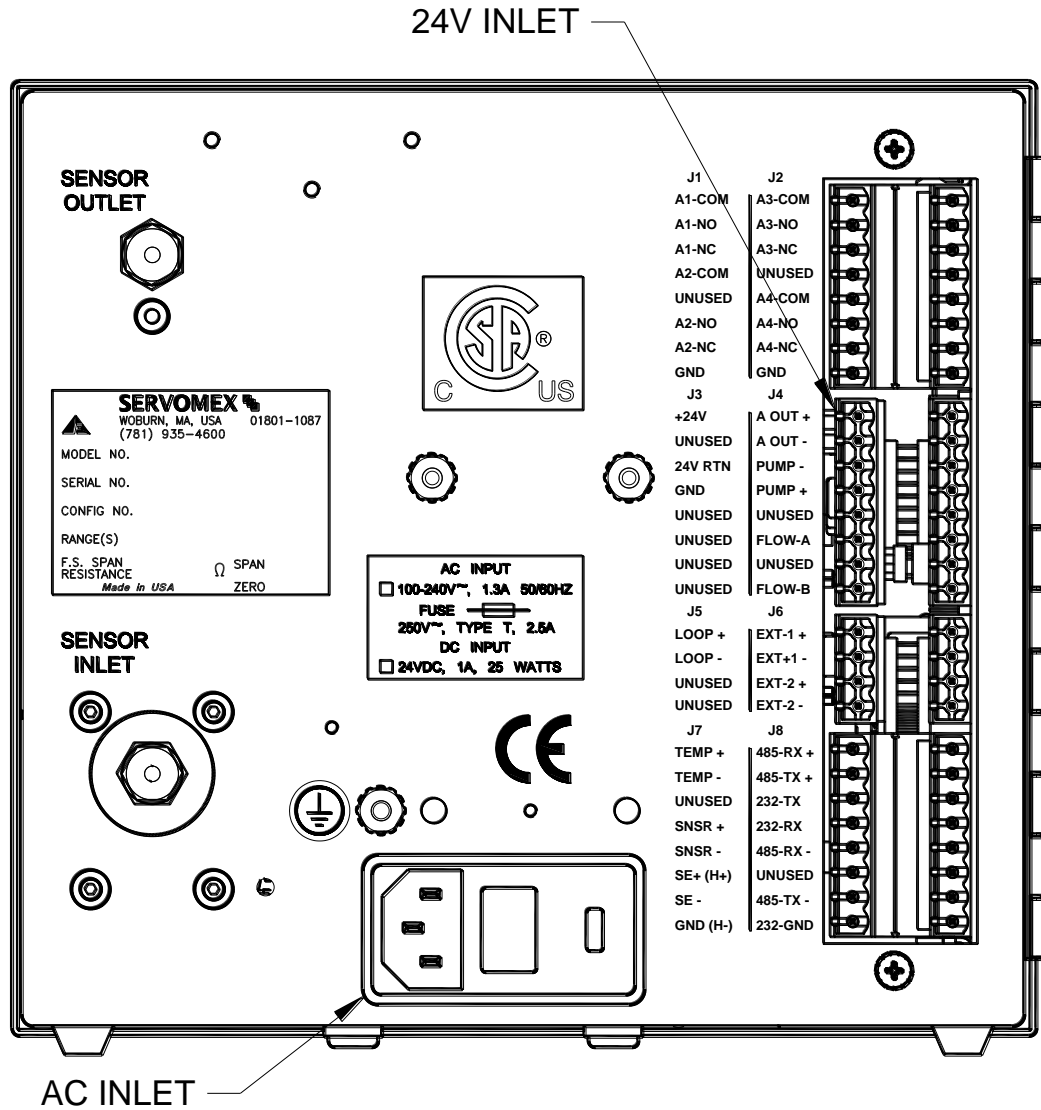

Figure 6: Rear Panel

5 Options

5.1 Pump

The On-board Pump allows the analyzer to operate on gas sample streams between 2.0 psig vacuum and 2.0 psig positive pressure.

If the analyzer has a pump, it will also have a downstream Flow Control Valve mounted in the bottom of the flow meter. When using the pump, always use this downstream valve to control the gas flow rate and leave all up stream valves wide open.

If the pump is not in use, (positive pressure application) always control the gas flow with an upstream valve or regulator and leave all down stream valves wide open.

CAUTION



Do not use an upstream valve to control flow if the analyzer is operating on a pump.

5.1.1 Pump Control

The on-board pump, if equipped, can be controlled from the Controls Menu. See page 65 for additional information.

In addition the following options are available:

If factory configured, Servomex will supply the standard pump that the user may install remotely and power through the PUMP -, + (+12VDC) connections on the rear panel connector J4. Control would be accomplished in the same manner as an internal pump.

OR

If factory configured, a switch closure rated at 1A/30VDC can be supplied between the PUMP -, + connections on the rear panel connector J4. The contacts can be used to send a signal indicating the status of the internal pump or to control an external, Servomex supplied pump that is powered from a separate source.

OR

If factory configured the pump may be controlled remotely through the EXT signal on the J6 connector. See the section on Remote Controls on page 48 for additional information.

5.2 Battery Power

Analyzers equipped with a battery pack (AC powered units only) can be operated on battery power for four to eight hours, depending upon

configuration (see Table 1). Battery charging occurs only while the analyzer is connected to power and the power switch is turned on. The batteries can be charged while the instrument is not in service by turning off power to the oxygen sensor. See the Controls Menu as shown in Figure 34. Approximately 12 hours is required to fully charge a battery pack (16 hours if the pump is running) and several charge and discharge cycles may be required for optimum battery operation.

During battery operation “BAT” is displayed down the right side of the display. When the battery power is low, “LOW” is displayed down the right side of the display. In addition, the analyzer will beep. When the battery is *too* low, the analyzer will shut down automatically.

When operating on AC power, and the battery is low, “CHG” is displayed on the right side of the display. When the battery is fully charged nothing is displayed down the right side of the display.

Turning off the backlighting conserves battery power.

| Analyzer State | Length of Time the Battery will Provide Power |
|---|---|
| Options and Outputs off, Backlight in Auto Mode | 8 hours |
| Options and Outputs off, Backlight On | 4 hours |
| Pump On, Backlight in Auto Mode | 4 hours |
| Outputs on, Backlight in Auto Mode | 6 hours |

Table 1: Battery Operation Time

NOTE



Use only Servomex P/N 16337070 when replacing the NiMH battery pack.



*In the event that the NiMH Battery Option is installed in an analyzer that also has the Case Purge Option, the NiMH Battery system **must** be disabled. This will enable the analyzer to shut down properly in case the purge gas flow is reduced or lost completely.*

5.3 Low Flow Alarm

The optional low flow alarm includes a flow switch that is located in the enclosure on the right side. It is connected with vinyl tubing to the outlet of the flowmeter. If enabled, the option sounds an alarm when flow drops below a factory-set value and the O2 reading is covered by a reverse video block indicating ALM F FLOW. The switch can also be used with an optional alarm relay, if enabled. See Figure 7 for examples of various Analyzer plumbing configurations. The optional low-flow switch is included in configurations c and d.

If the stainless steel outlet option is ordered with a low flow alarm, the flow switch is mounted in the sample outlet line as part of the sensor assembly. A 2-pin connector is used to disconnect the switch from the analyzer.

5.4 Flow Control Valve

The upstream flow control valve is mounted behind the door and below the Flow Indicator. It may be used to control the gas flow rate in positive pressure installations where the inlet pressure is less than 5 psi. In addition, it may be shut off to isolate the analyzer from the gas stream.

5.5 Filter

The filter assembly is installed at the factory when ordered with the Analyzer. However, a filter assembly may be purchased later and installed by the user. It is mounted externally on the back panel as shown in Figure 8. The option includes a bracket and preformed tube with fittings to connect the filter outlet to the Analyzer inlet. The back panel of the Analyzer has three PEM nuts for mounting the filter bracket. Use the screws supplied with the PEM nuts.

Two grades of filter elements are available for the filter:

Fine grade (BQ) (< 1 micron)

Course grade (DQ) (> 1 micron)

The course grade is normally supplied. See page 96 for ordering information.

Note: The filter has two ports labeled 1 and 2. For particulate removal plumb the filter with port 2 connected to the Analyzer's sample inlet fitting. For mist coalescing and collection for draining, plumb the filter with port 1 connected to the Analyzer's sample inlet fitting.

5.6 Pressure Regulator

The gas pressure regulator is installed at the factory when ordered with the Analyzer. However, a gas pressure regulator may be purchased later and installed by the user. It is mounted on the back panel as shown in Figure 9. The option also includes a preformed tube with fittings to connect the regulator outlet to the Analyzer inlet. The back panel of the Analyzer has three PEM nuts for mounting the regulator bracket. Use the supplied screws with the PEM nuts.

Note: If the analyzer is equipped with a VCR welded sample inlet connection, there is a .010 inch orifice at the inlet to the sensor which requires 15-20 psig of pressure.

NOTE: For additional information on the proper purging of regulators after installation see page 37.

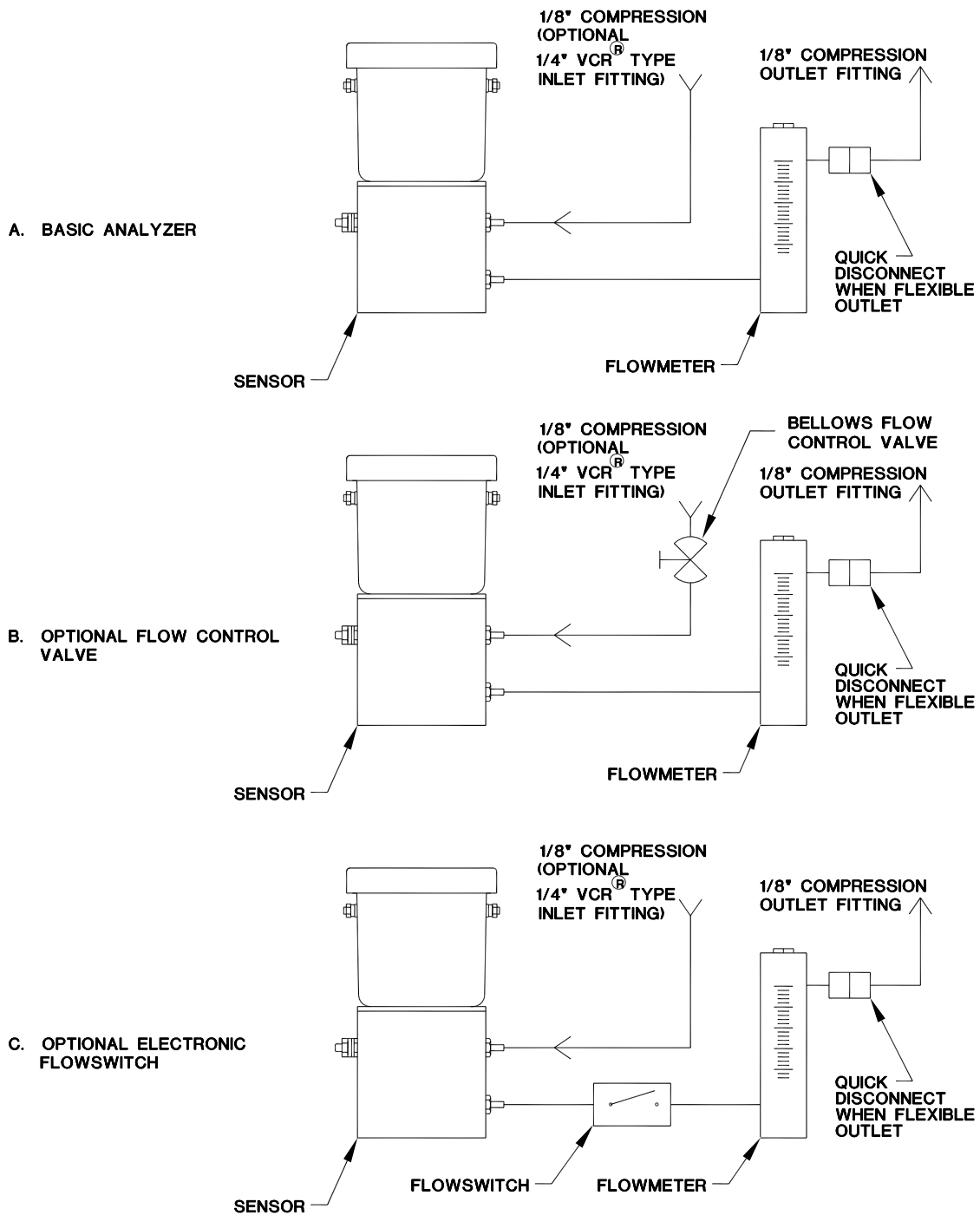

Figure 7: Plumbing Configuration Options

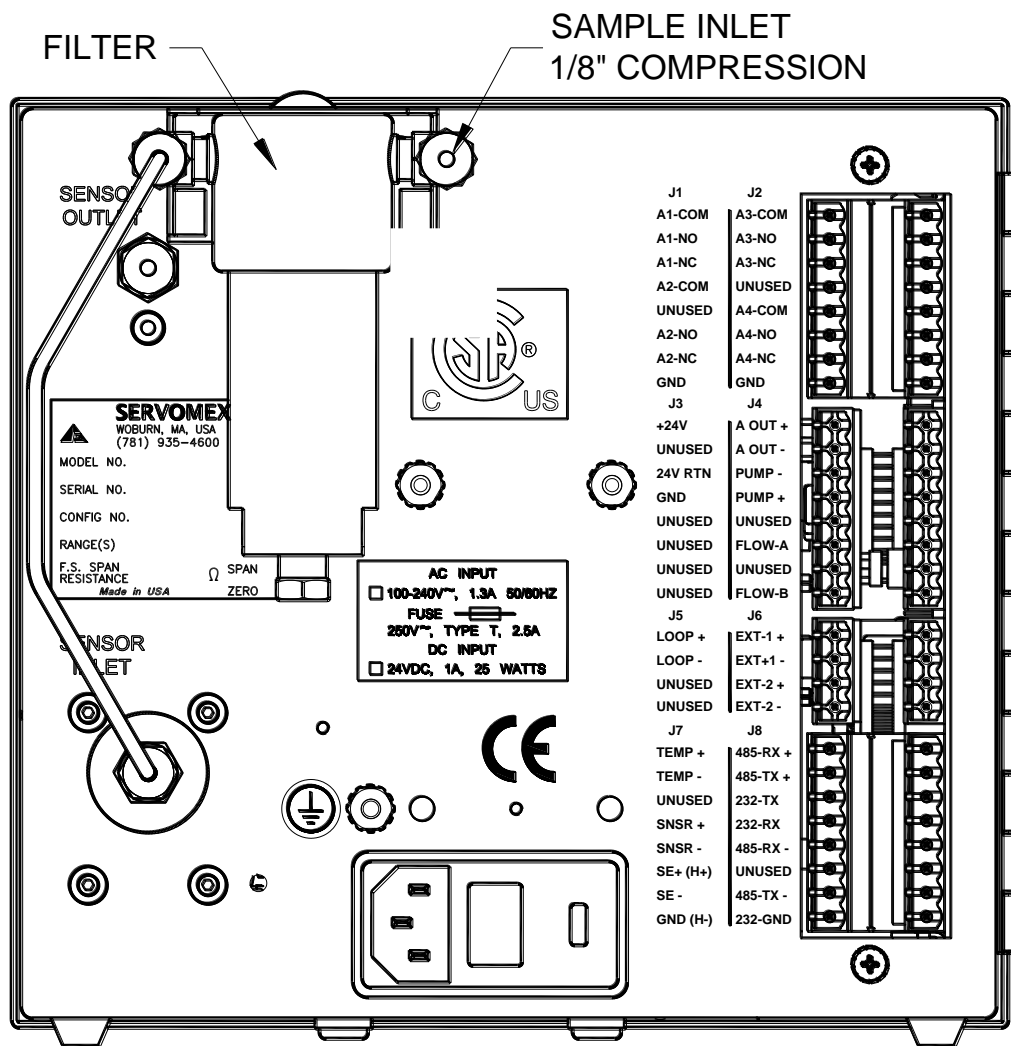

Figure 8: Filter Installation

5.7 Combined Filter/Pressure Regulator

The gas filter and regulator are installed by the factory when ordered with the Analyzer. However, the gas filter and regulator may be ordered later and installed by the user. They are supplied as a unit with one mounting bracket and mounting screws. The option also includes a preformed tube with fittings to connect the regulator outlet to the Analyzer inlet. These should be mounted on the back panel as shown in Figure 3-4 using the supplied screws.

Note: The filter has two ports labeled 1 and 2. For particulate removal plumb the filter with port 2 connected to the Analyzer's sample inlet fitting. For mist coalescing and collection for draining, plumb the filter with port 1 connected to the Analyzer's sample inlet fitting.

NOTE: For additional information on the proper purging regulators after installation see page 37

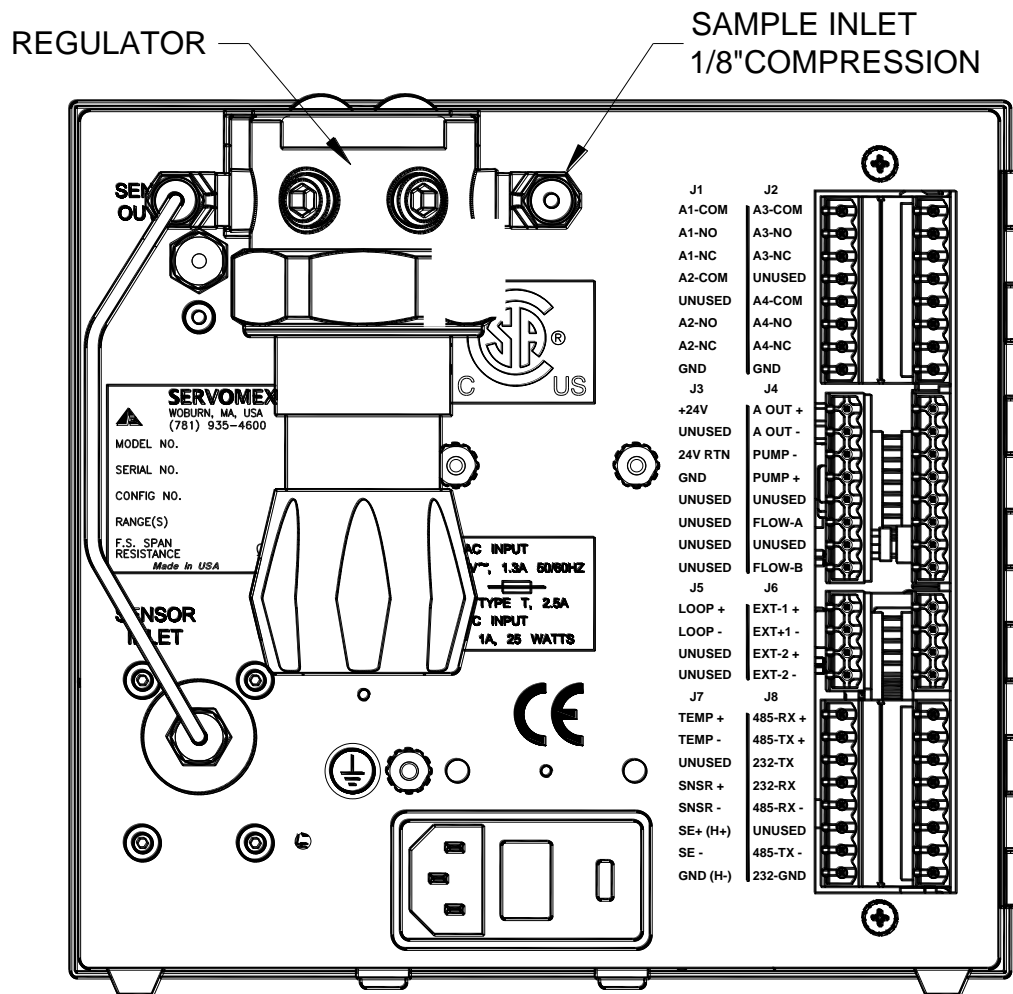

Figure 9: Regulator Installation

5.8 Stainless Steel Outlet Tubing

Analyzers can be equipped with a 1/8-inch compression stainless steel outlet tube. When this option is provided, the analyzer cannot be equipped with the quick-disconnect fitting at the flowmeter outlet. Because of the rigid outlet tube, the Sensor Assembly can only be removed after both inlet and outlet bulkhead retainer nuts are removed. A 7/16-inch wrench is needed for the inlet nut; and a 1/2-inch wrench is used on the outlet nut. When reinstalling the sensor, make sure both bulkhead fitting hex sections are oriented to seat in the retainer blocks on the inside rear of the enclosure.

5.9 Key Lock

An optional key lock can be installed in the door of the analyzer to prevent access to the power switch and other internal components. The lock is supplied with two keys.

If the analyzer is operating, the key lock does not prevent adjustments from the front panel. Password Protection, described in the *User Interface* section

under *Setup Analyzer Menu*, must be used to lockout front panel control changes.

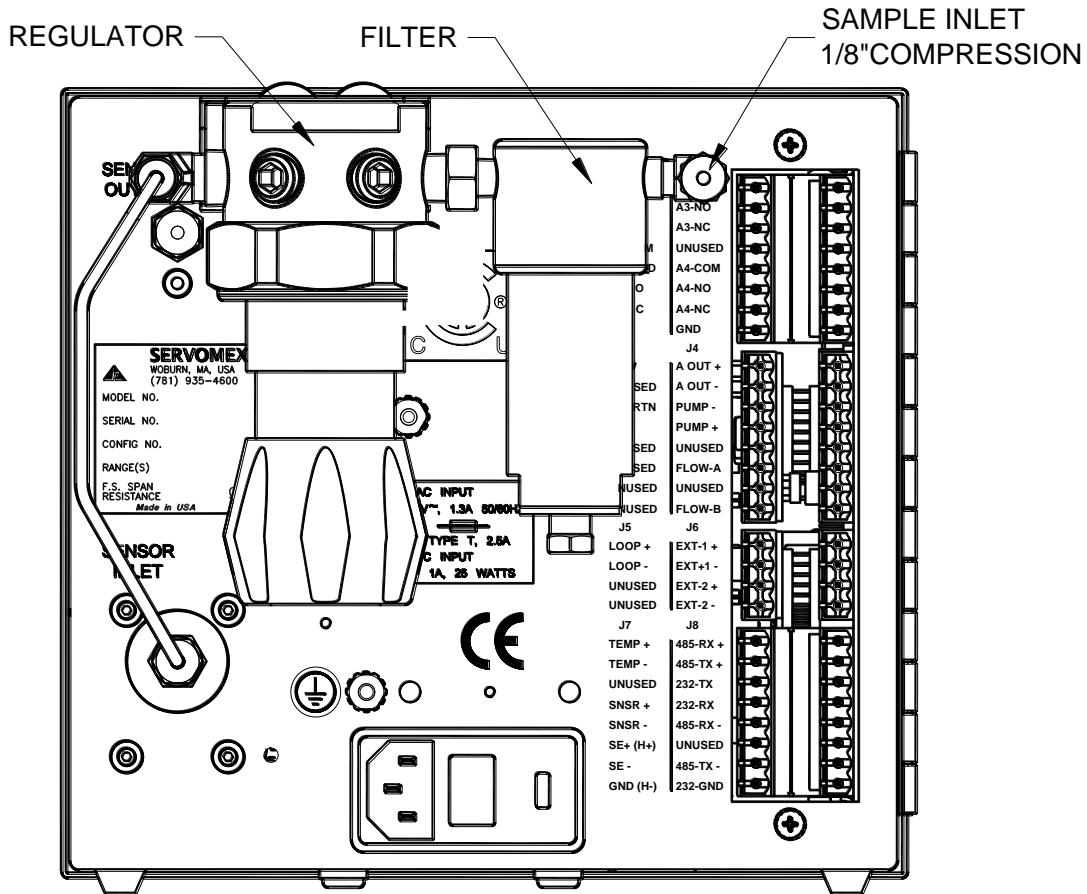

Figure 10: Combined Filter/Regulator Assembly

5.10 4-20mA Analog Output

The optional fully-isolated 4-20 mA output is completely isolated from all other analog outputs and from earth ground. The maximum loop resistance is 1KΩ. The 29-33 VDC compliance voltage is provided. Connections are made at pins J5-1 (LOOP+) and J5-2 (LOOP-) at the back of the instrument. See page 45 for additional information.

5.10.1 2-20mA Analog Output

If configured at the time of order, the optional 4-20mA output described above can be reduced to 2mA when the Sensor is either turned off manually or turned off automatically due to extended (30 minute) off scale oxygen readings. Use of this function provides information that could be interpreted remotely as an alarm or non-standard condition. See page 66 for additional information on the Sensor Off function.

5.11 Relays

Up to four optional form C (SPDT) relays (contact closures) are available to

assign to alarms or system status flags. One or more alarms or status flags can be assigned to one or more relays. The contacts are rated at 0.3A, 30 VDC under a resistive load. Pin assignments provide relay connecting details. See page 44 for additional information.

5.12 Communication Port – RS232/485

Either of two communication ports are available at the time of order: RS232C or RS485. This option allows interfacing between the analyzer and other operating systems. A “C” language software library package is available for customized development of communication software. See page 43 for additional information.

5.13 Expanded Range Scale

The optional expanded range scale allows the analog output scaling to be automatically expanded to a larger value when the primary scaling range is exceeded. See page 72 for additional information.

5.14 Panel Mount

A panel mount option is available. See Figure 11 and Figure 12 below for details.

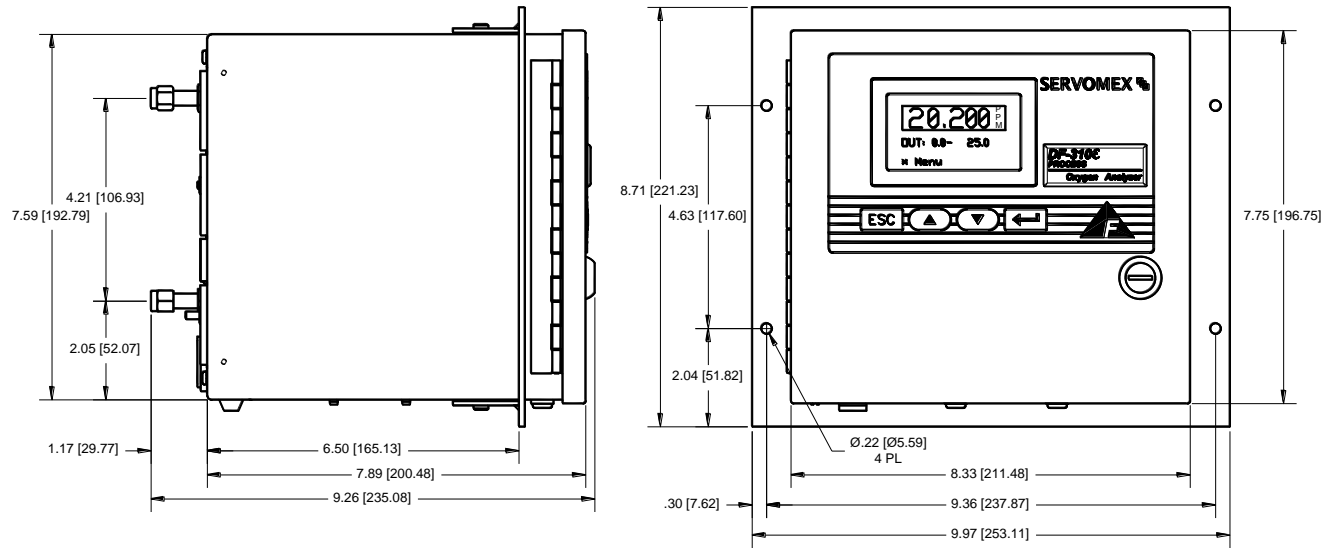

Figure 11: Panel Mount Configuration

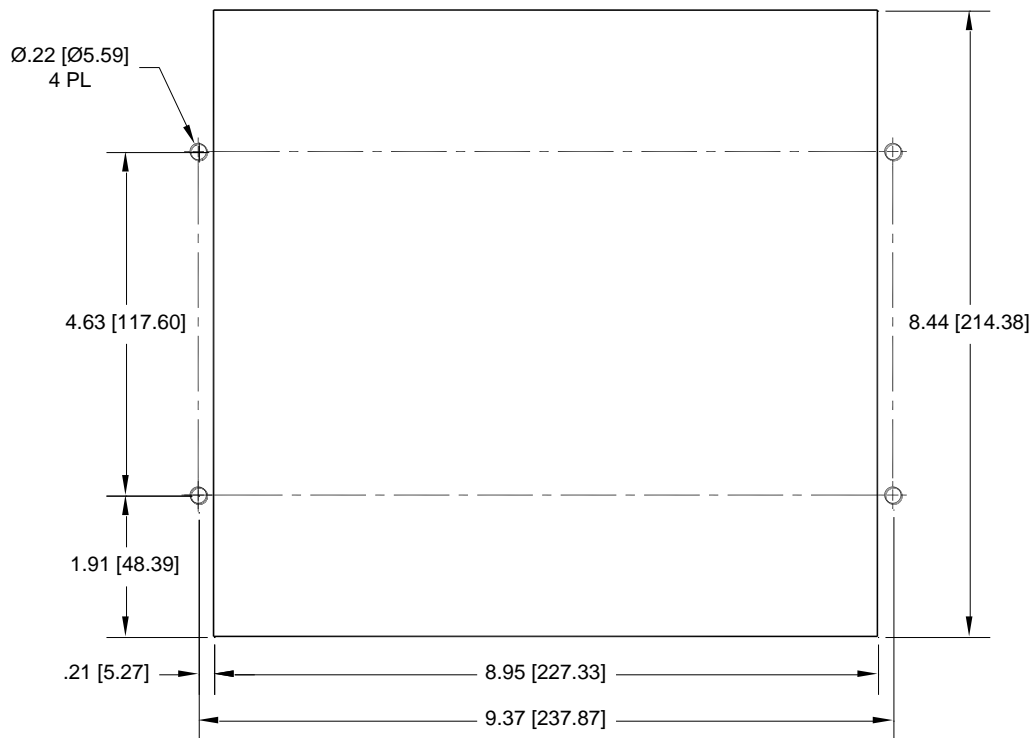

Figure 12: Cutout Dimensions for Panel Mount

5.15 Rack Mount

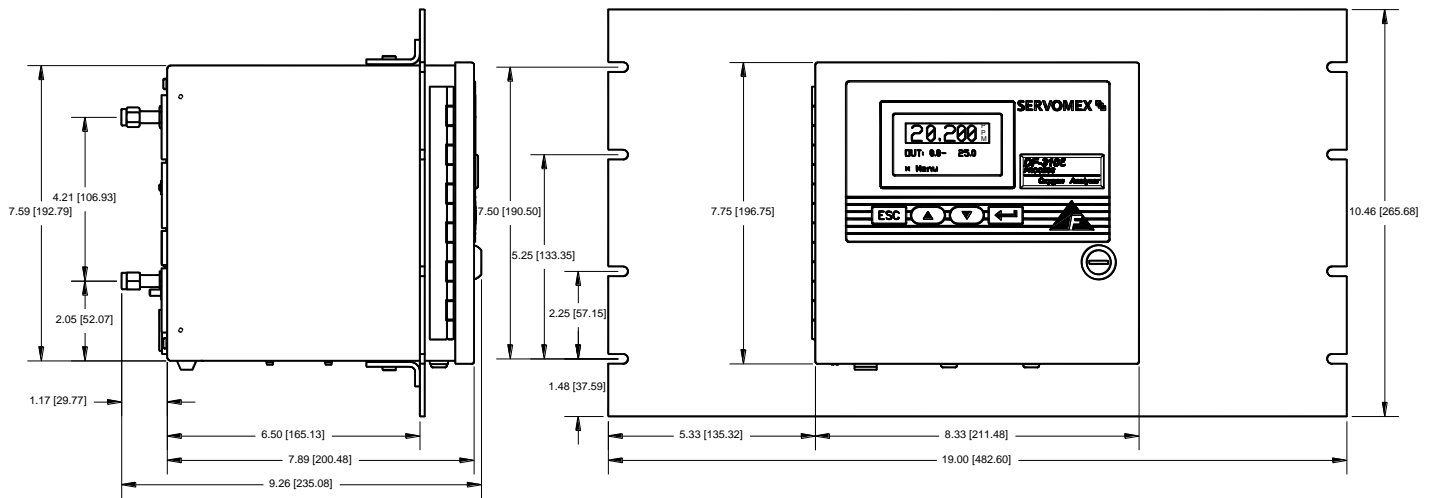

Figure 13: Rack Mount

5.16 Dual Rack Mount

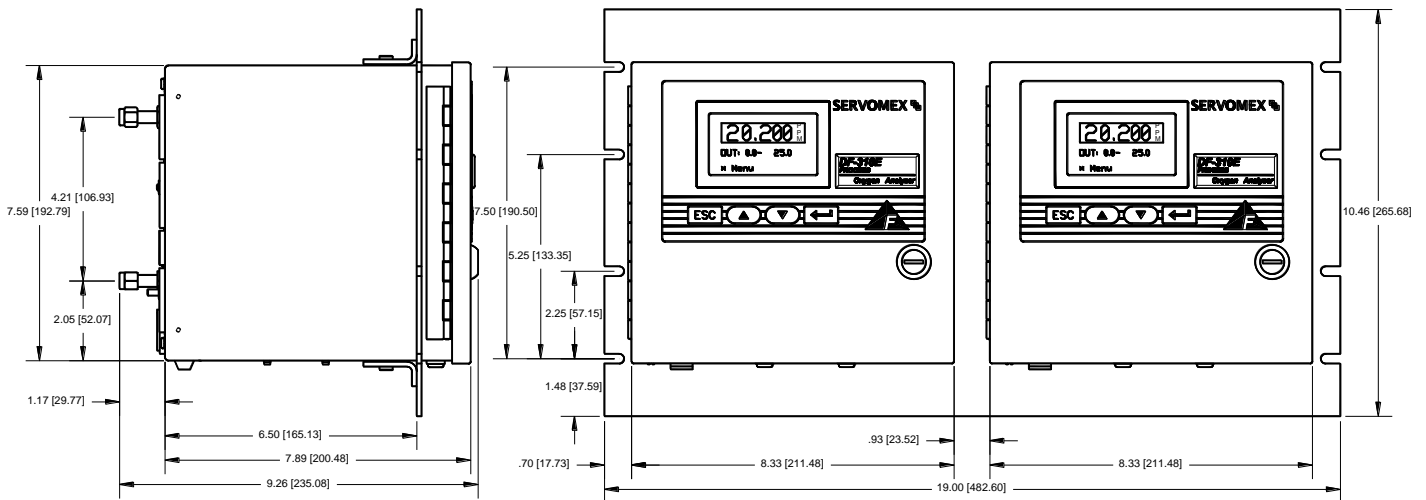

Figure 14: Dual Rack Mount

5.17 Remote Display

The display and keypad may be mounted remotely if noted at the time of order. Following are the dimensions for the hole cutout and mounting screws. The connecting cable must be shielded with the ground attached only to the stud on the rear of the analyzer and wired as shown in Figure 16.

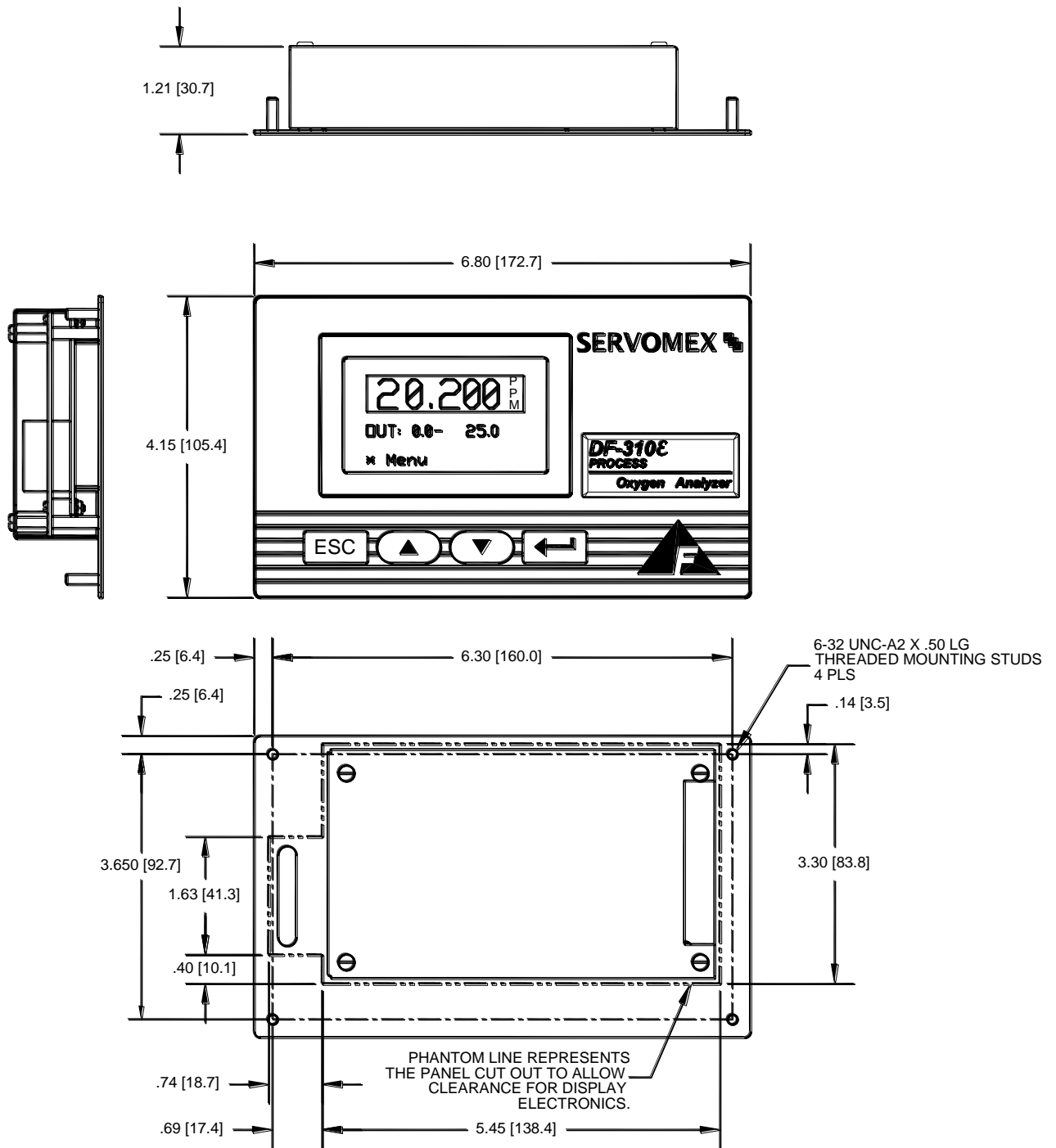

Figure 15: Remote Display

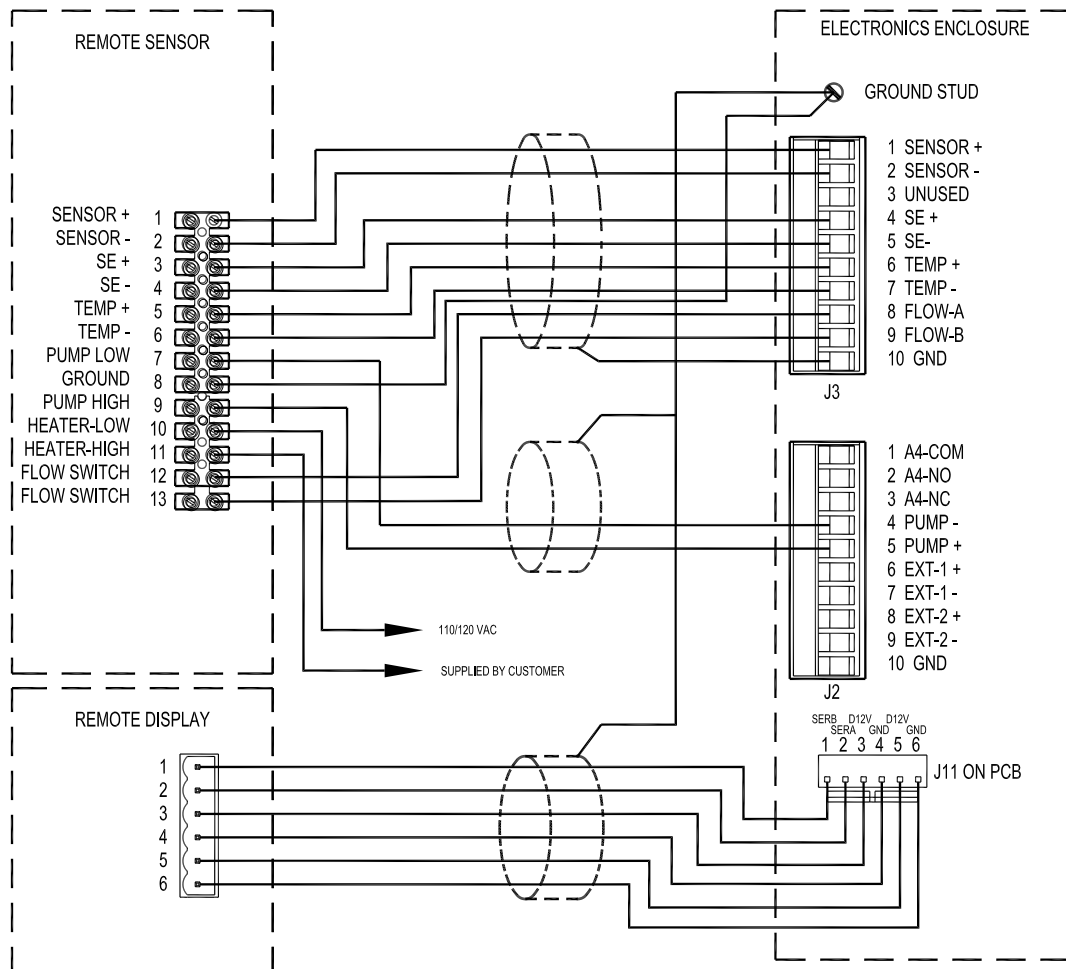

Figure 16: Remote Display Wiring

5.18 Case Purge

NOTE: The case purge option is available on AC powered analyzers only. The *DF-310E* analyzer can be equipped with an inert gas (nitrogen) purge system. The purge system provides improved protection against an explosion hazard by purging the enclosure to a concentration level below the lower explosive limit.

With a 10 scfh flow, the nitrogen purge system provides a minimum of thirty volume changes per hour of the atmosphere inside the analyzer's enclosure. A low-flow switch controls the failsafe feature. AC power is connected to the analyzer through the purge control as long as the low-flow switch contacts are closed. In the event of a partial or full loss of purge gas flow, the low-flow switch opens causing a hermetically sealed relay to disconnect power to the analyzer.

The electrical and purge gas connections are at the rear of the analyzer. The

purge system has a maximum supply pressure rating of 100 psig and is connected via a 1/8-inch compression fitting. Dry nitrogen is recommended. AC power is connected by the user at the three-terminal connector block next to the purge gas inlet. See Figure 17.

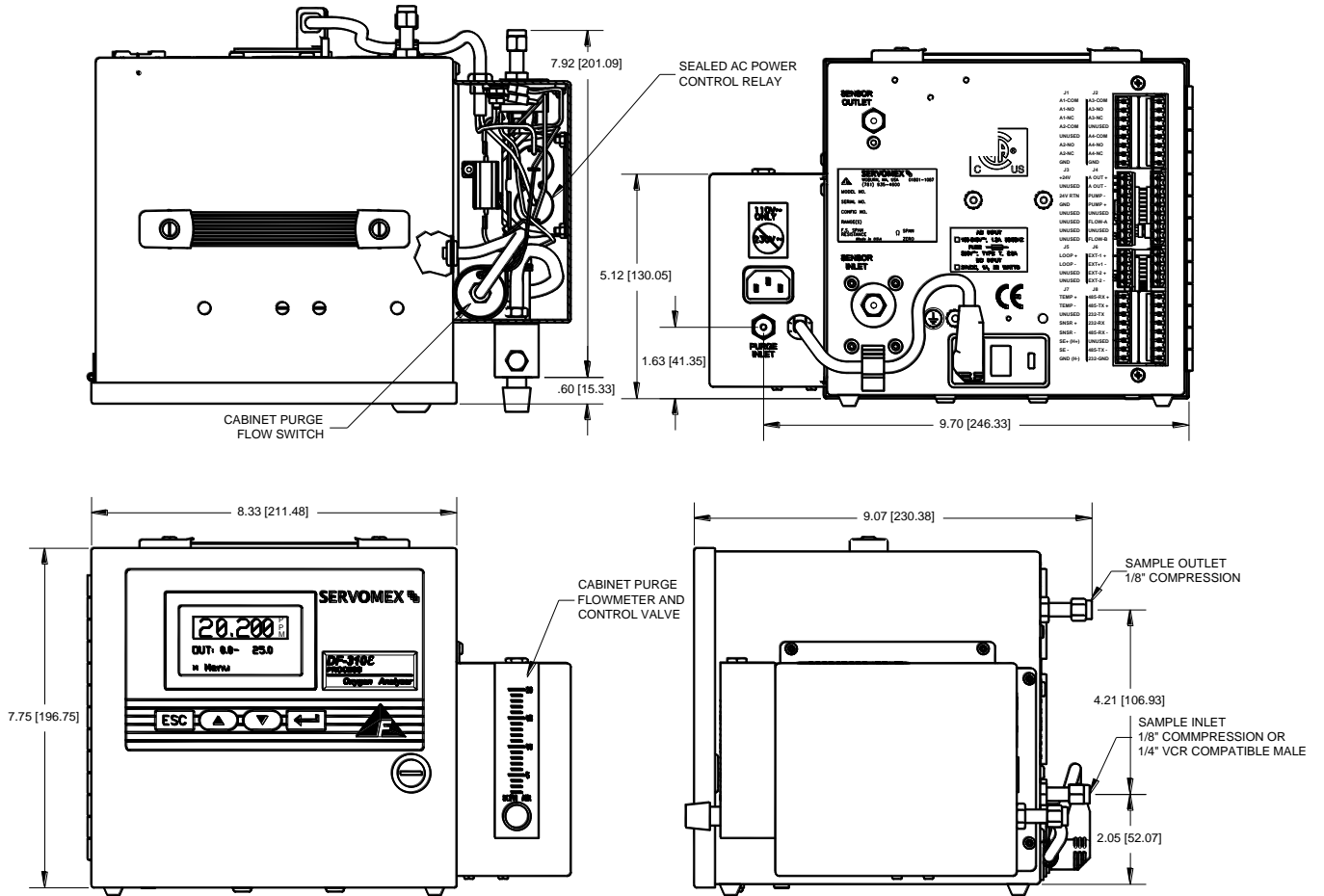

Figure 17: Case Purge Option

6 Sample Gas Preparation and Delivery

6.1 The STAB-EL Acid Gas System

With the STAB-EL system oxygen measurements in sample gases containing varying amounts of acid gases are possible. As a general guide, the data in Table 5-1 represents the maximum allowable limits of acid gases under continuous operation that can be tolerated with the STAB-EL system.

| Measuring Range Of Analyzer | CO ₂ * % | SO ₂ ppm | H ₂ S ppm | NO _x ppm | Cl ₂ ppm | HCL ppm |
|-----------------------------|---------------------|---------------------|----------------------|---------------------|---------------------|---------|
| 0-50 ppm | 0.1 | 100 | 100 | 100 | 50 | 50 |
| 0-100 ppm | 0.2 | 200 | 200 | 200 | 100 | 100 |
| 0-500 ppm | 0.2 | 200 | 200 | 200 | 100 | 100 |
| 0-1000 ppm | 0.4 | 500 | 500 | 500 | 200 | 200 |
| 0-5000 ppm | 0.6 | 1000 | 1000 | 1000 | 400 | 400 |
| 0-10,000 ppm | 0.8 | 1500 | 1500 | 1500 | 800 | 800 |
| 0-5% | 2.0 | 2600 | 2600 | 2600 | 1400 | 1400 |
| 0-10% | 4.0 | 4000 | 4000 | 4000 | 2000 | 2000 |
| 0-25% | 6.0 | 6000 | 6000 | 6000 | 3000 | 3000 |

* Concentrations of CO₂ are in percent. One percent is equivalent to 10,000 ppm.

Table 2: Maximum Allowable Acid Gas Limits

Contact the local Servomex Business Center for recommendations on using the STAB-EL sensor on acid gases other than those listed above.

The STAB-EL limits shown in the table represent rough guidelines for continuous exposure. In most cases, substantially higher acid gas levels can be tolerated on a limited duty cycle basis. For example, a 0-100 ppm sensor can be used to sample a 100% CO₂ background gas for a 15 minute period 3-4 times per week, and the balance of the time sampling from a clean gas like N₂, Ar, H₂, etc. In general, a good guideline is to limit that the loading on the STAB-EL system to not exceed the continuous limits if the total exposure is averaged over a weekly period. Consult with Servomex for details.

There are applications where the acid gas components may exceed the upper limits of the STAB-EL system on a continuous basis. In such circumstances a sample dilution system can easily be fabricated to mix clean N₂ with the sample gas in a 2:1 to 20:1 ratio using simple pressure control and flowmeter

components. Depending upon the continuous acid gas level and the oxygen level to be measured, a dilution ratio must be selected such that the resulting O₂ level is accurately measurable and at least one order of magnitude above the O₂ level in the N₂ dilution gas. Contact the local Servomex Business Center for specific recommendations.

Another approach when acid gas levels are continuously above the STAB-EL limits is to enhance the inherent capabilities of the sensor by using a scrubber system. The scrubber will remove the bulk of the acid gases, allowing the Analyzer to provide continuous stable measurements. If a breakthrough occurs, the sensor's ability to tolerate high levels of acid gas for limited periods of time will avoid catastrophic loss of performance.

Servomex offers a broad range of scrubbers for applications in severe environments. Standard scrubber columns are available in various sizes, and in single or dual bed configurations. The columns are fabricated from clear PVC and are designed to accept a variety of different acid gas absorbent media which have a color-change indication to facilitate convenient change-out. For more information, contact the local Servomex Business Center.

6.2 Sample Gas Scale Factor

The optional **GSF** (Gas Scale Factor) is used to correct for changes in the rate of oxygen diffusion when background gases other than nitrogen are present in the process or sample gas.

In many applications, the sample GSF does not need to be altered from the default value of 1.00. However, if the sample gas has a significantly different diffusivity compared with nitrogen (such as helium or hydrogen), the GSF should be applied. To use the GSF feature, the volumetric percentages of the sample gas are entered as described on page 79 and the total GSF is automatically calculated by the analyzer. Alternately, the GSF factor can be entered manually.

The software in the analyzer supports gases as shown in Table 3.

Contact the local Servomex Business Center for assistance with gases not listed.

For additional information see the section on Gas Scale Factor in the User Interface chapter on page 79.

| | |
|-----------------|--------------------------------|
| Ammonia | NH ₃ |
| Argon | Ar |
| Butane | C ₄ H ₁₀ |
| Carbon Monoxide | CO |
| Ethane | C ₂ H ₆ |
| Ethylene | C ₂ H ₄ |
| Helium | He |
| Hexane | C ₆ H ₁₄ |
| Hydrogen | H ₂ |
| Methane | CH ₄ |
| Nitrogen | N ₂ |
| Propylene | C ₃ H ₆ |

Table 3: Gas Scale Factors

6.2.1.1 Disclaimer

The method used to correct the calibration of the DF-310E Oxygen Analyzer for measurement in non-nitrogen background gases is derived from a well-known theoretical mass transfer equation. This equation accounts for the change in oxygen diffusion rates through different gases.

Although significant empirical work has been done in this field, it is generally accepted that the equation may be only 85-90 percent accurate. In addition, there is further error introduced when correcting for a "multi" component background gas. This may result in up to an additional 3-5% error.

An alternate method when using a non-nitrogen or "multi" component background gas for spanning is to obtain a certified Calibration standard that has been prepared in a background gas that models the average process sample. Care must still be used, however, as certified standards may also have an inaccuracy associated with them.

Questions regarding the calculation of a background gas correction factor for a specific application should be directed to the local Servomex Business Center.

6.3 Sample Flow Rate and Pressure

The analyzer is factory calibrated at a flow rate of 1.0 scfh, in N₂, and should be operated at that level for optimal accuracy. However, the Servomex Sensor is relatively unaffected by gas sample flow rate, within limits. Sample flow rate should be maintained within the recommended range of 1.0 to 2.0 scfh.

The analyzer can be operated at flow rates outside that range, but it should be recalibrated at that different flow rate to maintain optimal accuracy.

The analyzer has a small pressure drop (0.2 to 0.5 psi), so relatively small changes in inlet or outlet pressure causes dramatic changes in flow rate.

Consequently, it is preferable to vent the outlet to atmosphere so that outlet pressure remains constant, leaving inlet pressure as the only variable to control.

6.3.1 Flow Rate Effects on Sensor Performance

Assuming a leak-tight system, higher flow rates may cause O₂ readings to increase by a few percent of reading above the level that would be displayed if flow was within the recommended 1.0 to 2.0 scfh range. Lower flow rates similarly cause O₂ readings to decrease by a few percent of reading. Very low flow rates (below 0.2 scfh) should be avoided as the sample inside of the sensor is no longer representative of the actual sample.

The insensitivity to flow rate changes is the basis for the sample system leak detection described below. The sensor output should be virtually constant for readings between 0.5 and 2.0 scfh. Therefore, if O₂ readings become higher at lower flows, then ambient O₂ is leaking into the sample system, or venting from a dead space (closed pocket with trapped higher O₂ level gas) in the sample system. A higher flow rate dilutes the O₂ entering the sample system decreasing the reading. O₂ readings in a leak free sample system should not go up or down significantly with flow changes between 0.5 and 2.0 scfh.

6.3.2 Checking for Plumbing Leaks using Flow Rate Effects

Significant measurement error can be caused by leaks in the plumbing system. A simple test can be performed to identify oxygen intrusion leaks.

Observe the analyzer readout at two flow levels: 0.5 and 2.0 scfh. Only a slight increase, if any, in readout will occur in a tight system as the flow is increased. If leakage in the plumbing system exists, then the increased flow results in a substantial decrease in oxygen readout -- typically dropping by 25 to 50 percent.

When flow sensitivity is observed, check the plumbing system for leaks. Once proficient with this test, the user can estimate the distance to the leak based on the response time of the reading changes.

6.3.3 Background Gas Effects on Indicated Flow Rate

If the molecular weight of the background gas is much different from N₂, the flowmeter reading is not accurate. The Rotameter type is calibrated for use in air (or N₂). Most other gases have molecular weights within ± 25 percent of air. Since the required flow rate is not extremely critical most gases produces reasonably correct readings. The exceptions are light gases such as Helium and Hydrogen whose flow rates should be set to approximately one-third that of Nitrogen or 0.3 scfh.

6.3.4 Regulator Requirements

If the pressure in the sample line varies, but does not drop below 2.0 psig, use a regulator to drop the pressure to approximately 1.0 psig. Set final flow rate with the sensor flow control valve.

If a regulator is not used, the flow rate changes when the pressure at the inlet of the flow control valve changes. As long as this pressure variation does not bring the flow rate out of the recommended flow range (1.0 - 2.0 scfh) no regulator is required. A flow change of ± 1.0 scfh may result in a small change to the oxygen reading.

If a pressure change causes the flow rate to move outside the recommended range, an adjustment of the flow control valve must be made. If the adjustment is not made, and the flow rate remains outside the recommended range, the analyzer may not be operating within its stated accuracy.

6.3.5 Pressure Regulator Purge

Regulators used on bottled calibration standards are typically equipped with 2 Bourdon pressure gauges, one to measure the cylinder pressure, and the other to measure the outlet pressure. The regulator must have a metal (preferably stainless steel) diaphragm. It is good practice to install a flow control valve to adjust the flow after the regulator.

All user-added upstream plumbing should be consistent with the instrument gas delivery components so that the highest level of integrity can be maintained. All connections should be welded or include metal face-seal components.

Pressure gauges are not recommended on regulators used on process sample lines because they add measurement delay time and offer opportunities for leaks.

6.3.5.1 Regulator Purge Procedure

Before the gas is connected to the analyzer follow the procedure listed below to purge ambient air from the regulator:

After securely attaching the regulator to the cylinder,

1. Open the regulator flow control valve slightly.
2. Open the cylinder valve.
3. Set the regulator to its maximum delivery pressure.
4. Adjust the flow control valve to allow a modest flow rate (hissing sound).
5. Close the cylinder valve until the cylinder pressure falls to zero. If equipped with gauges, allow the secondary (output) gauge to approach zero. Otherwise wait for the hissing to nearly stop.
6. Immediately open the cylinder valve to restore full delivery pressure.
7. Repeat steps 5 and 6 five to ten times to thoroughly purge the regulator and gauges.
8. Close the shut off valve on the outlet side of the regulator to isolate the purged regulator from atmospheric contamination.

Set the delivery pressure to 5 psig (15 psi for welded sample line with VCR connection).

The above procedure insures that any ambient air trapped in the pressure gauges and cavities of the regulator is purged prior to use. Once the regulator is mounted, do not remove it from the cylinder until a fresh cylinder is required.

6.3.6 Pressure Effects on Sensor Performance

If the analyzer is not vented to atmosphere, the sensor pressure is influenced by the conditions downstream of the analyzer. A recalibration under your operating conditions may be desirable to remain within the stated accuracy

specifications. However, in most cases the error introduced is relatively small, and may not affect the process application.

NOTE



It is not recommended that gauges be installed upstream of the analyzer. The presence of a gauge increases response times and introduces potential leaks to ambient.

Sample gas line lengths, fittings and bends should be kept to a minimum to maintain low pressure drops. Larger diameter tubing and fittings reduce pressure drop and also lengthen response time. In general, 1/8-inch tubing should be limited to 15-foot runs; longer runs should be made with 1/4-inch tubing.

6.3.7 Sample Outlet Backpressure Effects

It is always recommended to vent the analyzer to atmospheric pressure. However, if a sample vent or return line is used, attention must be given to maintain a low and consistent backpressure so as not to affect the flow rate. The allowable backpressure on the sensor is ± 1 psig. If variations in the vent line pressure are expected, a sub-atmospheric backpressure regulator should be installed on the vent line to maintain an even backpressure on the analyzer. Consider the regulator's pressure drop (typically 1 psi) when designing the sample vent system in order to stay within the ± 1 psig pressure limits at the sensor.

When not venting the analyzer to atmosphere, it is also suggested to install a fairly high resolution pressure gauge immediately at the analyzer outlet.

NOTE



If a regulator or gauge is installed on the analyzer outlet, the Stainless Steel Downstream Plumbing option should be installed.

6.4 Sample Gas Compatibility

There are a wide range of considerations in determining the gas sample compatibility of the Process Oxygen Analyzer. Servomex attempts to identify all pertinent application details prior to quoting and order processing. All non-typical applications concerning gas sample compatibility must be reviewed by our in-house Application Engineers. It is impossible to accurately predict all of the chemical tolerances under the variety of process gases and process conditions that exist.

6.4.1 Condensation

The analyzer should be installed and operated with a sample gas that is preconditioned (if necessary) to avoid condensation in the gas lines. Several methods are available to minimize the possibility of condensation. If the

sample gas is a hydrocarbon, maintain the gas temperature 20° F to 40° F above its dew point. In some applications, it may be necessary to chill the sample gas before it enters the analyzer so that the hydrocarbons can be condensed, collected, and removed. It is good practice to pitch the sample gas lines to allow condensables to drain away from the analyzer. Gas sample delivery lines that contain sample gases with high moisture content must not be exposed to temperatures below the dew point.

6.4.2 Gas Solubility in Aqueous KOH Solution

Some sample gas constituents are soluble in the sensor's potassium hydroxide (KOH) electrolyte. Gases that are rated as "Soluble" to "Infinitely-Soluble" may pose a threat to the sensor.

The sensor should have limited exposure (less than 1% by volume on a continuous basis) to highly water soluble alcohols, such as methanol, and/or be supplemented with periodic electrolyte changes to limit buildup within the electrolyte.

Many gas species with infinite solubility in aqueous KOH (such as nitrous oxide (N₂O)), however, do not affect the electrode or sealing materials, or interfere with the O₂ reduction/oxidation reactions. Contact the local Servomex Business Center for recommendations on a specific application.

6.4.3 Reactivity with KOH Electrolyte

Many process sample streams contain various concentrations of acid gases. Acid gases are gases that react with the basic KOH electrolyte solution to form a neutralized solution. The sensor does not operate properly when the electrolyte solution is neutralized.

Besides a neutralization of the electrolyte, a base reactive sample gas may have other negative effects, such as a base-catalyzed polymerization reaction. The O₂ electrode reaction sites may become blocked by the polymerized byproduct residue at the interface where the gas sample meets the electrolyte.

6.4.4 Flammable Sample Gas

There is nothing within the analyzer sample system that can ignite a flammable sample gas. However, it is critical to ensure that the sample gas does not escape from the sample system into the analyzer enclosure, or the room, where ignition is possible. Stainless steel plumbing should be used throughout the entire sample system if the sample gas is flammable. Also, the analyzer enclosure can be purged with nitrogen, or the entire Analyzer can be mounted in a purged enclosure, so that any sample gas that escapes the plumbing is diluted.

6.4.5 Trace acids in the sample gas

With the STAB-EL Acid Gas system, oxygen measurements in sample gases containing certain levels of acids are possible. Trace acids are common byproducts of gas distribution system assembly and its accessories. Trace acids can compromise the accuracy of the sensor and its construction if they are not managed properly. See the section Stab-el Acid Gas System on page

33 for more detail.

Contact the local Servomex Business Center for recommendations on using the STAB-EL sensor on acid gases other than those listed.

6.4.6 Sample Gas Temperature

Gas temperature should not exceed 50 °C (122° F), nor should it fall below 0° C (32° F). Gas temperature can be controlled by passing the gas through 5 to 10 feet of metal tubing that is within the recommended sample temperature. Because of its low thermal mass, the gas sample quickly reaches the gas sample line temperature.

Ideally, the analyzer should be operated at a nominal temperature of 70° F. Calibration temperature should be close to operating temperature. If the analyzer is to be operated at an average ambient temperature outside 65° F to 80° F, it should be recalibrated at the operating temperature for optimal performance.

NOTE



The sensor temperature can be displayed at any time by accessing the Diagnostics Menu, Figure 56. This temperature value is updated at intervals of 15 to 45 seconds.

6.4.7 Protecting the Analyzer from Process Upsets

The analyzer should be protected from extended exposure to high concentrations of oxygen or hostile gases. Automatically solenoid controlled valves should be installed to switch the analyzer over to an N₂ purge when the process reaches some identifiable condition.

Gas line maintenance operations must also be examined for their effect on the analyzer. For example, in many pipeline process or normal gas applications the plumbing system is cleaned with either a liquid solvent or detergent solution. Since either causes damage to the sensor, switch the analyzer over to a N₂ bypass purge, or shut off sample flow and power to the analyzer prior to initiating the potentially hazardous process.

6.5 Calibration Gas Considerations

Calibrations performed from a bottled, calibrated sample gas, may introduce additional issues that could adversely affect the analyzer calibration.

6.5.1 Calibration Standards

Certified calibration standards are available from gas manufacturers. These standards are available in steel and aluminum cylinders. Steel cylinders are less expensive but do not dependably maintain a stable oxygen concentration for long periods of time.

Calibration standards in aluminum cylinders are recommended. Servomex has found that calibration standards in aluminum cylinders are very stable for

long periods of time (between 6 and 24 months) where steel cylinders should be recalibrated every three months.

6.5.2 Calibration Cylinder Regulators

Regulators used on bottled calibration standards are typically equipped with two Bourdon pressure gauges, one to measure the cylinder pressure, and the other to measure the outlet pressure. The regulator must have a metal (preferably stainless steel) diaphragm. Install a flow control valve after the regulator to adjust the flow.

6.5.3 Purge Procedure

Before the calibration gas is connected to the analyzer follow the procedure listed below to purge ambient air from the regulator which prevents contamination of the gas in the cylinder rendering it useless:

After securely attaching the regulator to the cylinder,

1. Open the regulator flow control valve slightly.
2. Open the cylinder valve.
3. Set the regulator to its maximum delivery pressure.
4. Adjust the flow control valve to allow a modest flow rate (hissing sound).
5. Close the cylinder valve until the cylinder pressure falls to zero. If equipped with gauges, allow the secondary (output) gauge to approach zero. Otherwise wait for the hissing to nearly stop.
6. Immediately open the cylinder valve to restore full delivery pressure.
7. Repeat steps 5 and 6 five to ten times to thoroughly purge the regulator and gauges.
8. Close the shut off valve on the outlet side of the regulator to isolate the purged regulator from atmospheric contamination.
9. Set the delivery pressure to 5 psig (15 psi for welded sample line with VCR connection).

Once the regulator is mounted and purged, do not remove it from the cylinder until a fresh cylinder is required.

6.5.4 Sample Gas Delivery and Vent Pressure during Calibration

The most accurate calibration is obtained when the analyzer is plumbed into the gas sample system so that the analyzer is under actual process operating conditions. But when the process sample is being delivered to the analyzer under Vacuum conditions, or being returned from the sample outlet under either positive pressure or Vacuum conditions the operating pressure at the sensor is likely to be quite different than under factory calibration conditions. For systems where the gas sample is not vented to atmosphere, the analyzer outlet should remain connected in the same manner during calibration, if possible. This ensures that downstream pressure effects on the sensor are the

same during calibration and process monitoring.

Use the flow control valve on the regulator to meter the calibration gas to the analyzer at the suggested 1.0 scfh flow. By leaving the analyzer's flow controls untouched from when the analyzer is used on process, the calibration pressure duplicates the process sampling pressure.

6.5.5 Background Gas Effects on Calibration

6.5.5.1 Flow rate

Ideally, the calibration gas and the sample gas have the same gas composition, and as a result, the indicated flow rate during calibration and process sampling are identical. However, if the composition of the calibration and sample gases are not the same, the flow rate indicated on the rotameter may need to be adjusted. Light gases, such as H₂ and He, have a higher flow rate than is indicated on the flowmeter. As a result, the flow rate of the light gas should be set to one third of the flow specifications found in this manual. For example: The recommended flow rate for N₂ is 1.0 scfh. In H₂ or He service, the recommended flow rate (*as indicated on the analyzer flowmeter*) is 0.3 scfh.

6.5.5.2 Gas Scale Factor (GSF)

If possible, the background of the calibration gas should be the same as the process sample gas. If not, a gas scale factor may have to be applied to the calibration gas oxygen readings because of the difference between the diffusion rate of oxygen in nitrogen (factory calibration gas) versus the diffusion rate in the user's calibration gas. *The Sample Gas Preparation and Delivery* section discusses the proper setting of the gas scale factor option during calibration as well as during process gas measurement.

7 Connecting to External Devices

The analyzer can be interfaced to a variety of external devices via the ports on the rear panel. Alarm contacts, voltage, and current outputs, and serial communications are supported.

NOTE



When using external devices to monitor the O2 reading, the analyzer should never be left in a menu screen unattended, but always in the O2 readout mode.

7.1 The Comm Port

The optional Comm Port is used for communication via RS-232C or RS-485 protocol. Up to 32 units may be accessed via RS-485. Operating parameters are 8 bits, no parity, and one stop bit. Baud rate may be selected from the menu on the display.

A library of interface functions, written in C, is available to allow programmers to create custom interface program for accessing the communication port. The *Interface C Library Reference Manual* comes with a disk containing Microsoft and Borland versions of the object code.

The Comm port (J8) terminals are defined as follows:

| | | |
|------|----------|---|
| J8-1 | 485-RX + | Data received by the analyzer from the device (RS-485) |
| J8-2 | 485-TX + | Data transmitted by the analyzer to the device (RS-485) |
| J8-3 | 232-TX | Data transmitted by the analyzer to the device (RS-232) |
| J8-4 | 232-RX | Data received by the analyzer from the device (RS-232) |
| J8-5 | 485-RX - | Data received by the analyzer from the device (RS-485) |
| J8-6 | UNUSED | |
| J8-7 | 485-TX - | Data transmitted by the analyzer to the device (RS-485) |
| J8-8 | 232-GND | Ground |

Table 4: Comm Port (J8) Connector Pinout

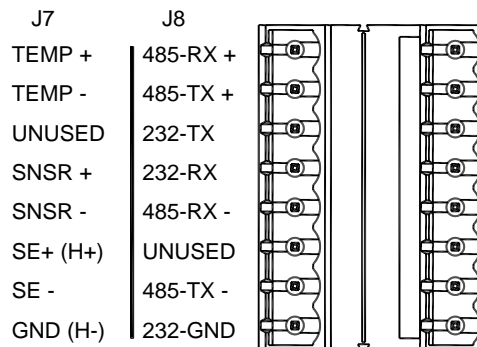

Figure 18: J7/J8 Connector Wiring

NOTE



To avoid ground-loop conflicts when using RS-232C or RS-485 for communications, make connections to external recorders or data acquisition systems through a differential input, or a single-ended input that is not referenced to Earth Ground.



When connecting the Process Oxygen Analyzer to a computer via an RS-232 or RS-485 communication cable, a Ferrite Sleeve is required around the cable in a single-turn configuration. It is recommended that the proper Servomex cable be used for this purpose.

7.2 Relay Ports

Connections to four optional form C (SPDT) relays (contact closures) are provided on the rear of the analyzer at connector J1 and J2. These can be used in conjunction with up to seven alarms. The contacts are rated at 0.3A, 30 VDC under a resistive load. They are not designed to switch AC power.

The relay contacts can be programmed for up to four Oxygen Alarms, plus Temperature, Low Flow, Electrolyte Condition and the Replenishment Solution Reminder alarm. A relay can be assigned to any alarm through the display menu.

The Normally Open (No alarm) contact connects to common when an alarm occurs or when power to the instrument is lost.

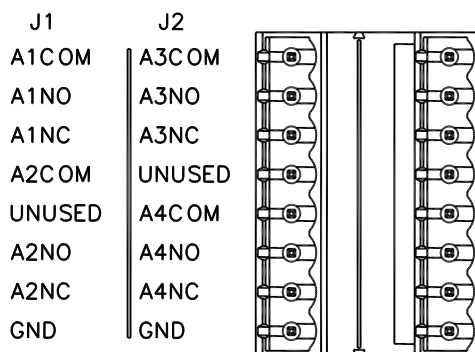

Figure 19: J1/J2 Connector Wiring

| | | |
|------|--------|-------------------------|
| J1-1 | A1-COM | Alarm 1 Common |
| J1-2 | A1-NO | Alarm 1 Normally Open |
| J1-3 | A1-NC | Alarm 1 Normally Closed |
| J1-4 | A2-COM | Alarm 2 Common |
| J1-5 | UNUSED | |
| J1-6 | A2-NO | Alarm 2 Normally Open |
| J1-7 | A2-NC | Alarm 2 Normally Closed |
| J1-8 | GND | Ground |

| | | |
|------|--------|-------------------------|
| J2-1 | A3-COM | Alarm 3 Common |
| J2-2 | A3-NO | Alarm 3 Normally Open |
| J2-3 | A3-NC | Alarm 3 Normally Closed |
| J2-4 | UNUSED | |
| J2-5 | A4-COM | Alarm 4 Common |
| J2-6 | A4-NO | Alarm 4 Normally Open |
| J2-7 | A4-NC | Alarm 4 Normally Closed |
| J2-8 | GND | Ground |

Table 5: Relay Port Connectors (J1, J2) Pin Out

7.3 Analog Outputs

In addition to the wiring of the analog outputs as described below, see page 70 for additional information on scaling the outputs through the firmware.

7.3.1 Analog Voltage Output

Connector J4 provides connections to the non-isolated analog voltage output signal (0 to 5, or 0 to 10 VDC, selectable). For details regarding how to switch the full-scale output see section 7.3.1.1 below.

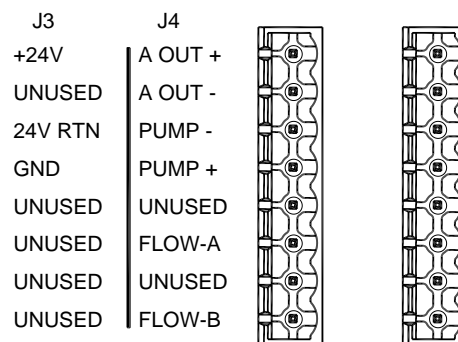

J3/J4 Connector Wiring

| | | |
|------|-------|-------------------------|
| J4-1 | AOUT+ | Analog Voltage Output + |
| J4-2 | AOUT- | Analog Voltage Output - |

Table 6: Analog Voltage Output Connector (J4) Pin Out

7.3.1.1 Procedure to change the Full Scale Analog Output Voltage

The following procedure should be used to change the full scale analog output voltage. The options are 5.0 and 10.0 VDC.

1. Shut-off and disconnect all power from the analyzer.
2. Label and remove all connections from the rear of the analyzer.
3. Open the door and disconnect the sensor and display cables. See page 13.
4. Remove the two screws from the rear of the unit. See page 18.

5. Remove the circuit board assembly from the cabinet.
6. Remove the four screws that hold the sheet metal cover in place. Remove the cover and set aside.
7. Locate jumper # JP14 in the center, directly below the relays in the upper third of the board.
8. Using the information in Table 7, place a jumper (short) between the appropriate pins to obtain the desired full scale output.
9. Reassemble and install the circuit boards back into the analyzer.
10. Reconnect all cables and power up the analyzer.
11. From the Diagnostics Menu, select Test Output, and set the output to 100% full scale.
12. With a DVM, confirm that the analog output voltage is proper. If it needs to be adjusted slightly, use the potentiometer located third from the top on the front of the circuit board, above the Servomex symbol.

| Full Scale Output Voltage | Jumper Number |
|---------------------------|---------------|
| 5.0 VDC | None |
| 10.0 VDC | 14 |

Table 7: Analog Output Voltage Jumpers

7.3.2 4-20mA Output

The optional fully-isolated 4-20mA output is completely isolated from all other analog outputs and from earth ground. The maximum loop resistance is 1K Ω . The 29-33 VDC compliance voltage is provided. Connections are made at pins J5-1 (LOOP+) and J5-2 (LOOP-) at the back of the instrument.

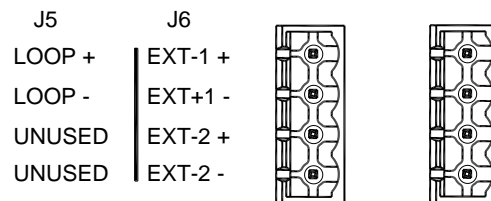

Figure 20: J5/J6 Connector Wiring

| | | |
|------|--------|------------------|
| J5-1 | LOOP + | 4-20 mA Output + |
| J5-2 | LOOP - | 4-20 mA Output - |

Table 8: 4-20 mA Analog Current Loop Connector (J5) Pin Out

7.3.2.1 Sensor Off 4-20mA Signal

If configured at the time of order, the optional 4-20mA output described above can be reduced to 2mA when the Sensor is either turned off manually or turned off automatically due to extended (30 minute) off scale oxygen readings. Use of this function provides information that could be interpreted remotely as an alarm or non-standard condition. See page 66 for additional information on the Sensor Off function.

7.3.3 Alignment Procedure for Analog Voltage and Current Loop Outputs

All output connections should be made before the alignment is started. It is assumed for the purpose of this alignment that the full-scale analog voltage output is 10 VDC.

Use the Test Outputs screen as described on page 89 to set the output to the desired level after which the alignment adjustments are made as follows:

1. Set the output to 0%
2. Adjust the analog voltage output (1) to 0.000 V +/- 10mV, adjust the current loop output (2) to 4.00mA +/- .05mA
3. Set the output to 100%
4. Adjust the analog voltage output (3) to 10.000 V +/- 15mV, and adjust the current loop output (4) to 20.00mA +/- .05mA.

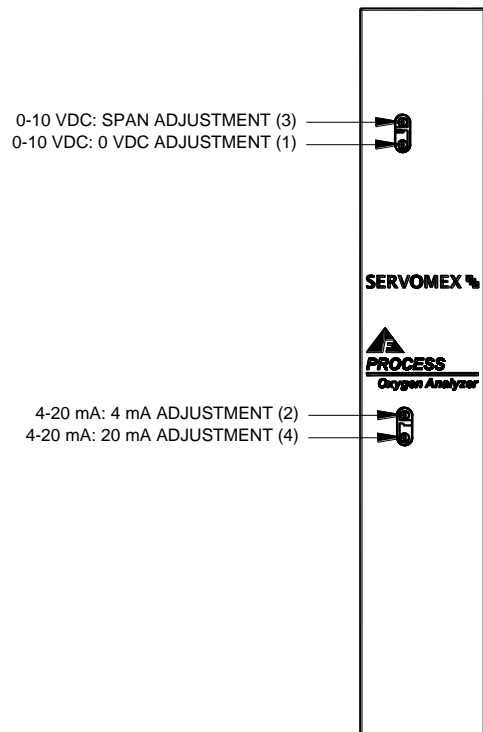

Figure 21: Analog Voltage Output and 4-20mA Adjustments

7.4 Remote Controls

7.4.1 Remote Sensor Control – J6 Connector

If equipped, the oxygen sensor can be turned on and off remotely through the pins labeled EXT 1 or EXT 2 on the J6 connector. If equipped, the EXT Functions screen, see page 91, will indicate to what set of EXT contacts this option is assigned, either 1 or 2.

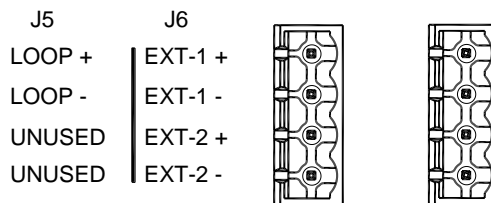

Figure 22: J5/J6 Connector Wiring

| | | |
|------|---------|----------------------------|
| J6-1 | EXT-1 + | External Control Input (+) |
| J6-2 | EXT-1 - | External Control Input (-) |
| J6-3 | EXT-2 + | External Control Input (+) |
| J6-4 | EXT-2 - | External Control Input (-) |

Table 9: Remote Control Connector (J6)

While the display is in the normal O2 mode, a voltage of 5-28VDC applied to the appropriate contact pairs labeled EXT 1 (+/-) or EXT 2 (+/-) will turn the sensor off. The oxygen sensor will stay off until this potential is removed.

NOTE: Turning the sensor off in this way will make control of the sensor from the keypad impossible. In addition, the Automatic Sensor off function is disabled.

NOTE: Controlling the sensor voltage in this way will disable the Automatic Sensor off function.

NOTE: The audible alarm normally associated with the sensor off function is disabled with this option. See the wiring diagram in Figure 30.

7.4.2 Remote Pump Control – J6 Connector

The pump enables the analyzer to operate on gas sample streams between 2.0 psig vacuum and 2.0 psig positive pressure.

If the analyzer is equipped with a pump, it will also have a downstream Flow Control Valve mounted in the bottom of the flow meter. When using the pump, always use this downstream valve to control the gas flow rate and leave all up stream valves wide open.

If the pump is not in use, (positive pressure application) always control the gas flow with an upstream valve or regulator and leave all down stream valves wide open.

CAUTION



Do not use an upstream valve to control flow if the analyzer is operating on a pump.

The on-board pump, if equipped, is controlled from the Controls Menu. See the User Manual for additional information.

Connections to power a remote pump are made through the PUMP – and PUMP + pins on connector J4. The wires should be in a shielded cable (separate from the sensor signal) with the shield attached to the frame ground. The pump cable should be of sufficient size for the required run (see Table 10 below) and should not share the same conduit as the sensor cable. See the wiring diagram in Figure 30.

| Pump Cable (Must be separate from sensor cable) | |
|--|--------------------------|
| Distance in Feet | Minimum Wire Size |
| 0 – 500 | #20 AWG |
| 500 – 1000 | #18 AWG |

Table 10: Pump Cable Specification

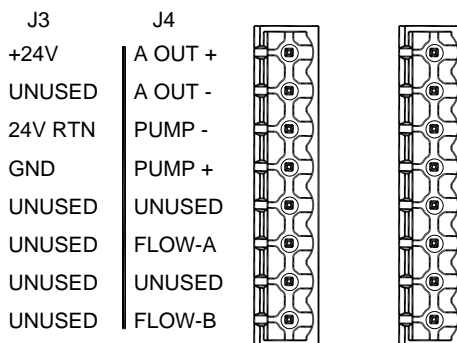

Figure 23: J3/J4 Connector Wiring

In addition, the following options are available:

If factory configured, Servomex will supply the standard pump that the user may install remotely and power through the PUMP – and PUMP + connections on the rear panel connector J4. Control would be accomplished in the same manner as a standard pump.

OR

If factory configured, a switch closure rated at 1A/30VDC can be supplied between the PUMP -, + connections on the rear panel connector J4. The contacts can be used to control a Servomex supplied pump that is powered from a separate 12 VDC, .3 A source. Control of the pump would be accomplished in the same manner as a standard pump.

OR

If equipped, the pump may also be turned on and off remotely through the pins labeled EXT 1 or EXT 2 on the J6 connector. If equipped, the Diagnostics Screen will indicate to what set of EXT contacts this option is assigned, either 1 or 2.

While the display is in the normal O2 mode, a voltage of 5-28 VDC applied to the appropriate contact pairs labeled EXT 1 or EXT 2 will turn the pump off. The pump will stay off until this potential is removed.

NOTE: Turning the pump off in this way will make control of the pump from the keypad impossible.

7.5 Remote Sensor Installations

NOTE – Remote sensor installations void CSA approval, if any.

The oxygen sensor for a DF Series analyzer may be installed outside of the analyzer cabinet. Areas of high convected or radiated heat must always be avoided. If installed outdoors, the sensor enclosure must be shielded from the sun to avoid overheating. In addition, a heater must be installed in the enclosure in areas where the temperature goes below freezing. (See page 53) Care must be taken to use high quality cable and techniques when making remote electrical

connections. See the wiring diagram in Figure 30 and refer to Table 10 and Table 11 for wire sizes and lengths. Following are three remote sensor configurations and wiring diagrams. Care must be taken when making up gas fittings on the sensor when mounted on a remote bracket as shown in Figure 24 below. A backing wrench must always be used (in particular for VCR connections) when connecting the gas sample line to the sensor. The inlet fitting, although epoxied, is very delicate and the seal can easily be damaged if it is allowed to spin as the connection is tightened. A 0.010 inch orifice is included with 0-50ppm sensors and must be installed at the sensor inlet in order to control gas flow. Contact Servomex for additional information on remote sensor installations.

7.5.1 Sensor on Remote Bracket with Optional Pump

CAUTION



Always use a backing wrench when connecting the gas sample line to a remote sensor.

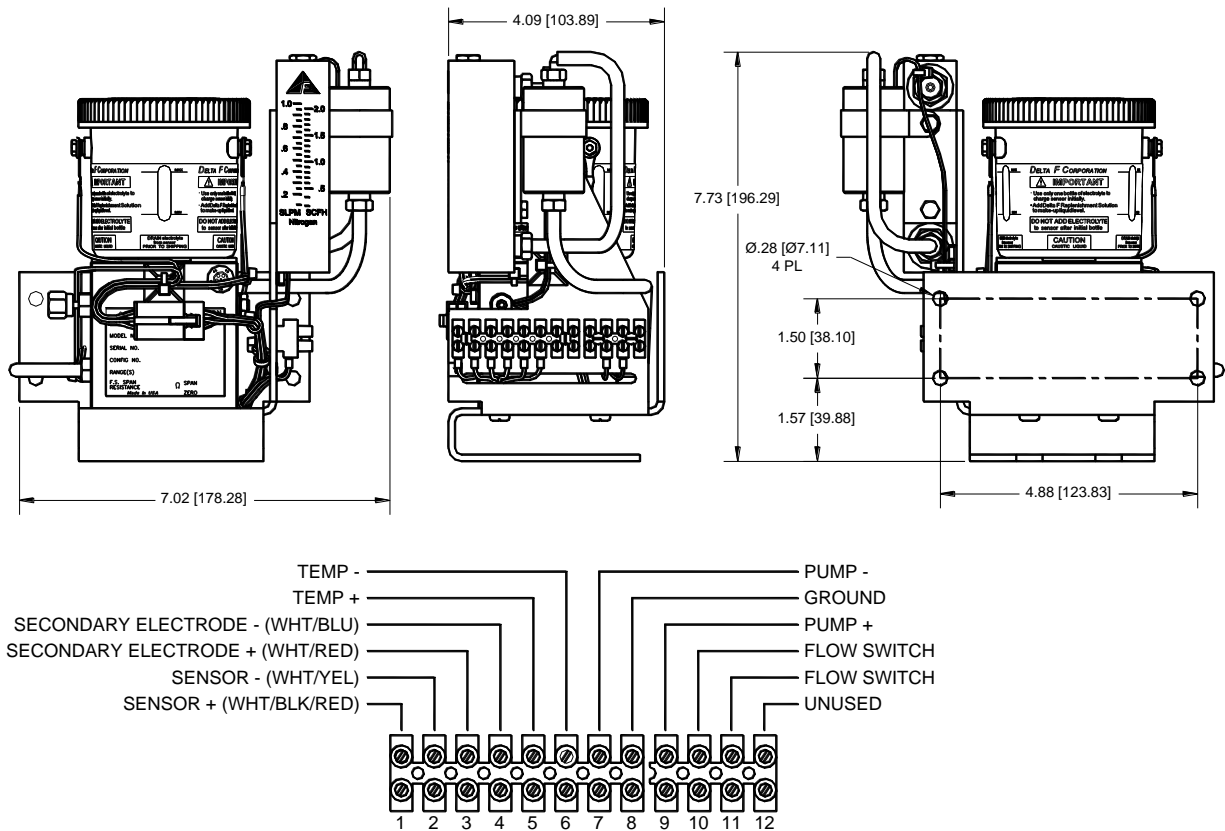

Figure 24: Remote Sensor with Optional Pump

7.5.2 Sensor in NEMA 4 Enclosure

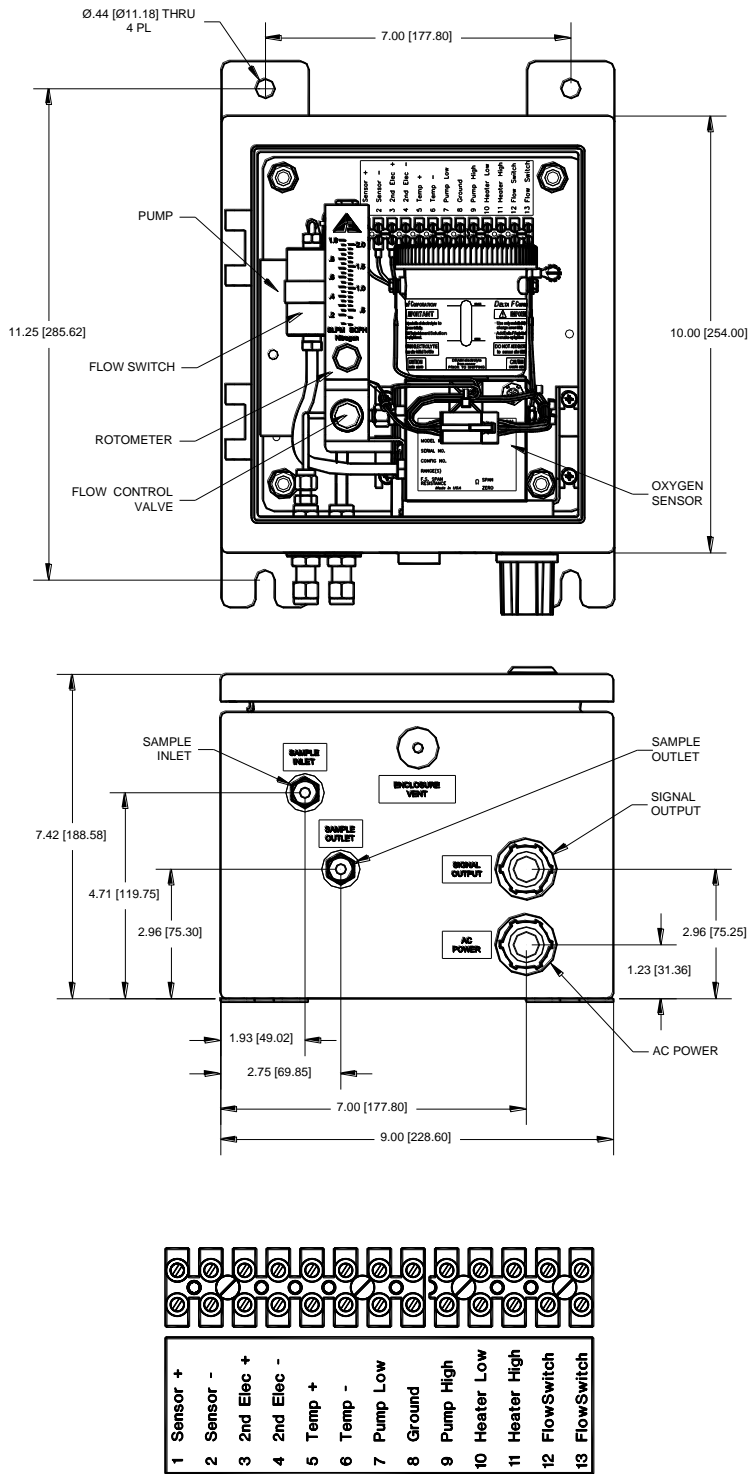

Figure 25: Remote Sensor Mounted in NEMA 4 Enclosure

7.5.3 Sensor in NEMA 7 Enclosure

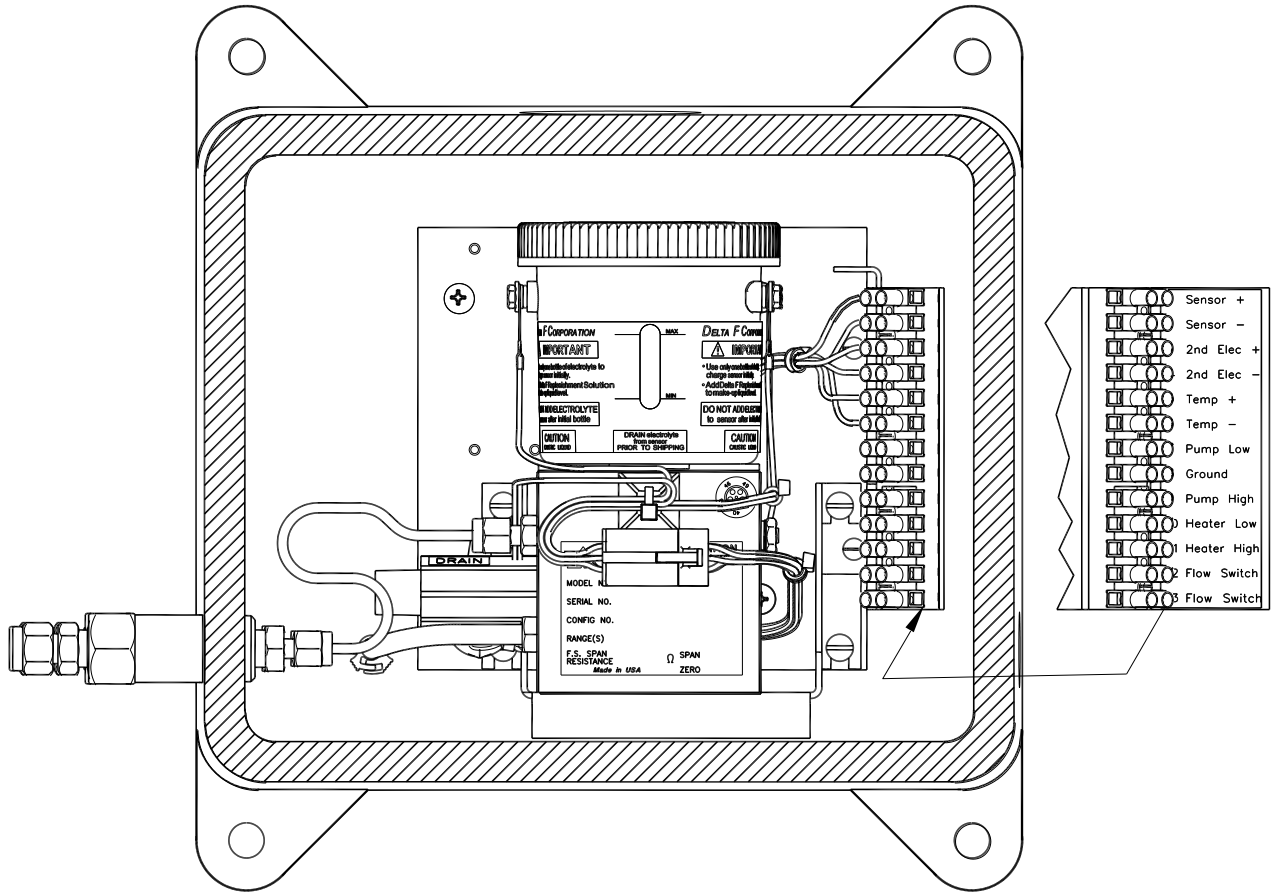

Figure 26: Remote Sensor Mounted in NEMA 7 Enclosure

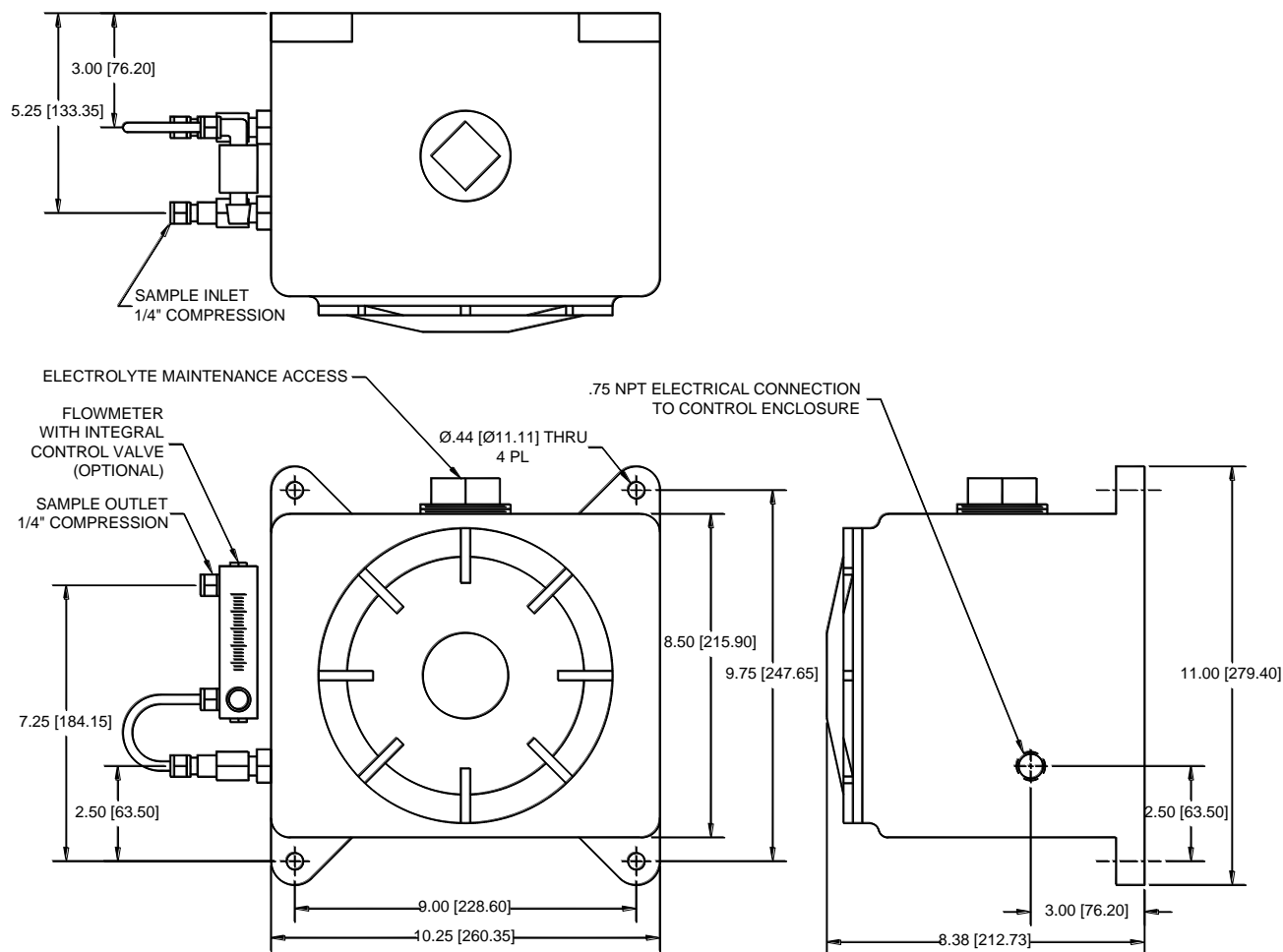

Figure 27: NEMA 7 Enclosure Mounting Dimensions

7.5.4 Temperature Control in R4/R7 Enclosures

R4 and R7 enclosures may be supplied with the temperature control option. Typically this option is installed in an effort to minimize diurnal changes in outdoor installations, or when the sensor must be kept at an elevated temperature in order to minimize condensation.

NOTE: The customer must supply the electrical power (110/220 VAC, 150 Watts) for this option.

For most applications, the sensor and electronics are maintained at a temperature of 65-70 degrees F. The temperature controller, located in the R4 or R7 enclosure, is set at the factory and typically requires no adjustment unless components are changed or application conditions require higher temperatures. In the event that the enclosure temperature must be adjusted, follow the steps below.

- 1) Obtain a temperature measurement device capable of measuring the desired operating temperature to an accuracy of +/- 2 degrees F.

- 2) Open the R4 door or remove the R7 cover. Attach the temperature measuring probe to the side of the oxygen sensor. Be sure to cover the enclosure opening to prevent cooling.
- 3) Turn on the analyzer and enclosure heater. Allow at least four hours for the enclosure temperature to stabilize.
- 4) Locate the temperature control potentiometer on the circuit board in the enclosure above the terminal strip. See Figure 28. Turn it clockwise to increase the temperature and counter-clockwise to decrease it. After each adjustment re-cover the enclosure and allow at least an hour for it to stabilize at the new temperature.

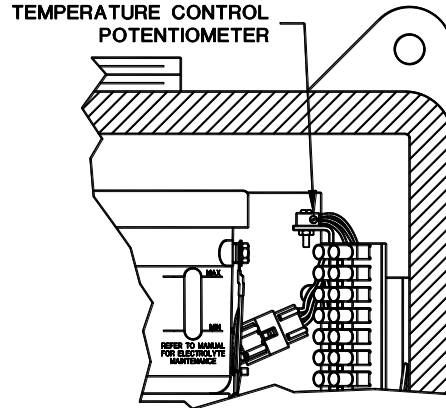

Figure 28: Temperature Control in R7 Enclosure

7.5.5 Remote Sensor Connections – Connector J7

There are three pair of connections that must be made between the oxygen sensor and connector J7 on the electronics chassis. They are labeled SNSR + and -, SE + and - and TEMP + and -. It is critical for optimum operation, and to prevent damage to the sensor, that the proper polarity be maintained on all electrical connections. These connections should be made through a shielded, twisted pair cable sized according to Table 11. The shield should be terminated *only* at the Ground connection labeled GND on the same connector. To avoid ground loops, the shield should be left open and *not* attached to the remote sensor chassis. See Figure 30 for wiring connections.

| Oxygen Sensor Cable Sizes | |
|---------------------------|-------------------|
| Distance in Feet | Minimum Wire Size |
| 0 – 150 | #20 AWG |
| 150 – 250 | #18 AWG |
| 250 – 350 | #16 AWG |
| 350 – 1000 | #14 AWG |

Table 11: Remote Sensor Cable Sizes

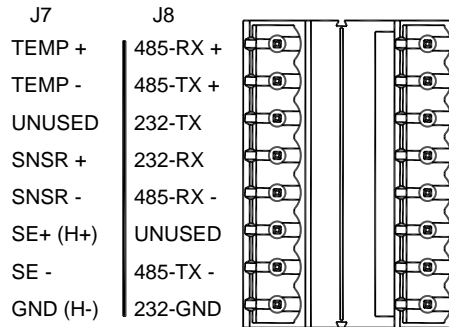

Figure 29: Remote Sensor Connector – J7

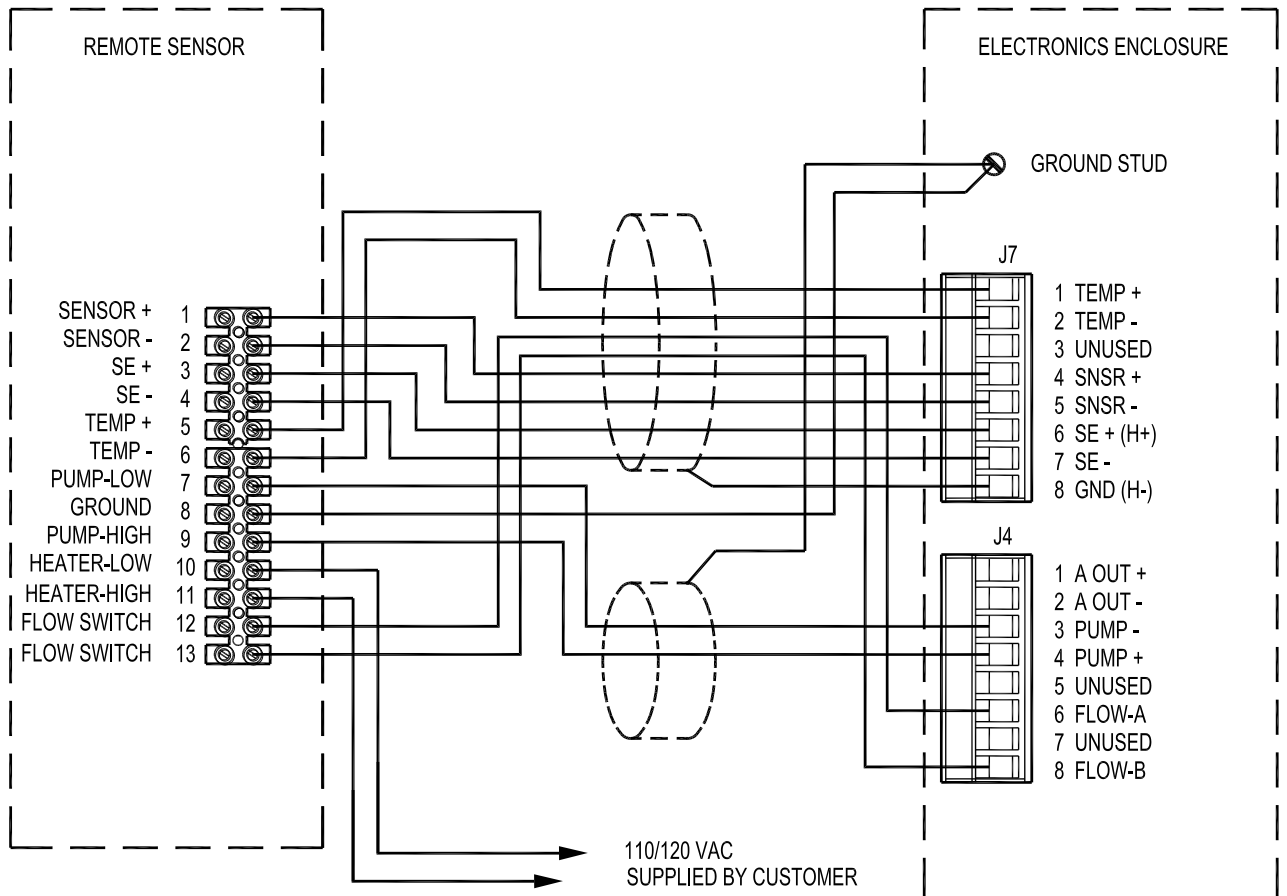

Figure 30: Remote Sensor/Pump Wiring Diagram

7.5.6 Z-Purge Protection on R4 Enclosure

Before applying power to the analyzer, the Z-Purge unit must be installed and operating properly. For loss of purge protection, wire the Z-Purge alarm contacts to a customer provided alarm. Normally open and normally closed contacts are provided. Alternatively the contacts can be used to interrupt the input power to the analyzer.

The switch requires either AC or DC input power, as indicated on the faceplate. For installation and wiring instructions, see the manufacturers information included with the switch.

NOTE: All electrical connections to the switch must be made according to applicable local and safety standards.

A supply of air or N₂ regulated between 25 – 250 psig is required.

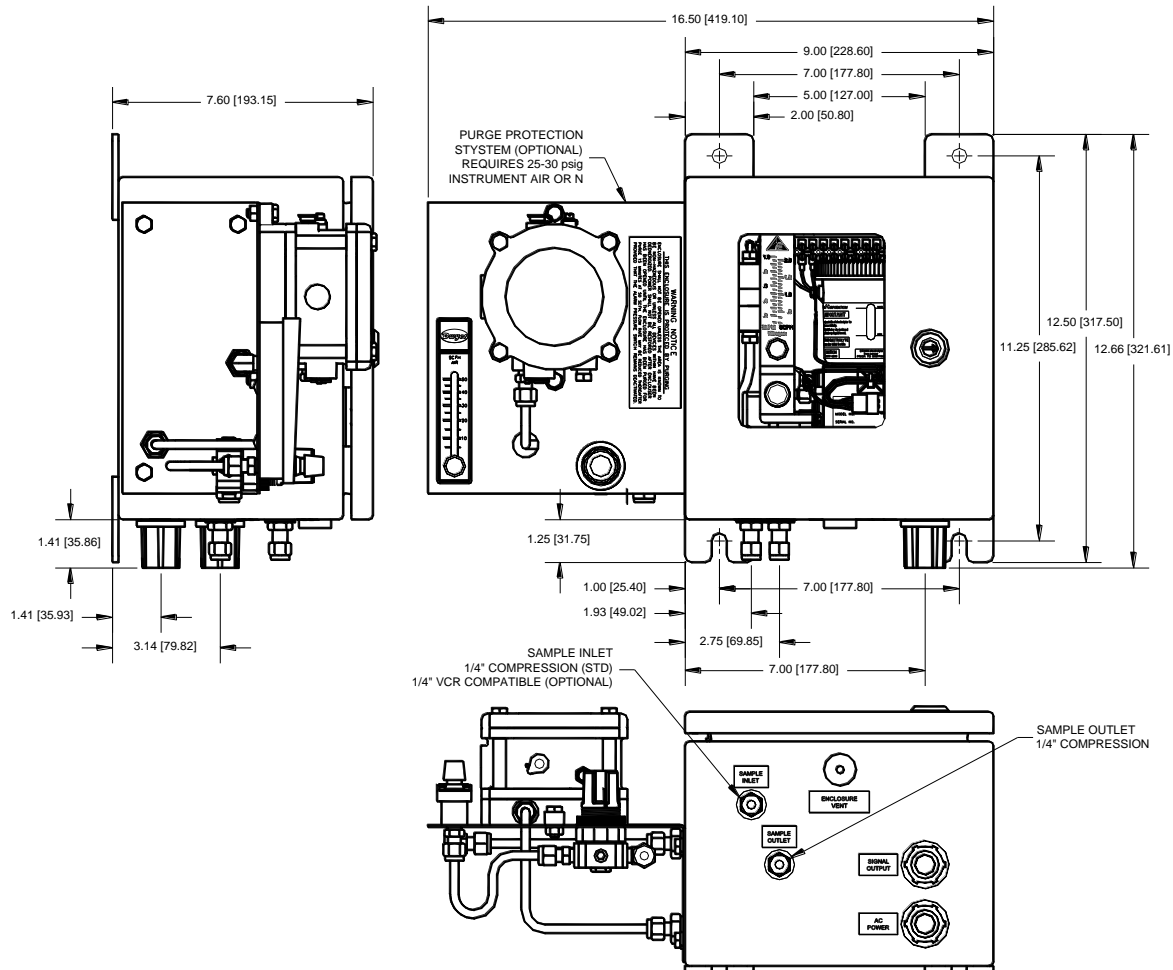

Figure 31: Z-Purge Protection on R4 Sensor Enclosure

Procedure for setting pressure and flow through the enclosure:

1. Verify proper operation of the Z-Purge unit as described in this section, while the environment is in a safe condition.
2. Remove the four cover screws on the Z-Purge pressure switch.
3. Check that the pressure calibration screw on the pressure switch is backed out as far as possible to the minimum pressure setting of 0.15 inches of water. Check the enclosure pressure with a suitable instrument if possible.
4. Close the Z-Purge pressure regulator (fully counter clock-wise)
5. Fully open the Z-Purge flowmeter needle valve. (fully clock-wise)
6. Open the instrument air/N₂ supply to the Z-Purge regulator. (pre-regulated to the minimum pressure required to supply 50 scfh of flow to the enclosure).
7. Open the Z-Purge regulator sufficiently to allow 50 scfh to the enclosure.
8. Verify that the alarm pressure switch has been deactivated (is not in an alarm condition).
9. Purge the enclosure for 15 minutes at 50 scfh.
10. Reduce the purge flow rate to a minimum of 5 to 10 scfh using the flowmeter needle valve, making certain that the alarm pressure switch remains deactivated (not in an alarm condition). If the purge switch activates, confirm that the enclosure is “tight” and increase the flow rate as necessary.
11. The analyzer may now be turned on.

8 User Interface

8.1 The Data Display Screen

When the DF-310E Process Oxygen Analyzer is powered up, it goes through a series of internal diagnostic tests which take about five seconds. After the tests, the Servomex logo appears for ten seconds. The display will then show the Data Display Screen as shown in Figure 32.

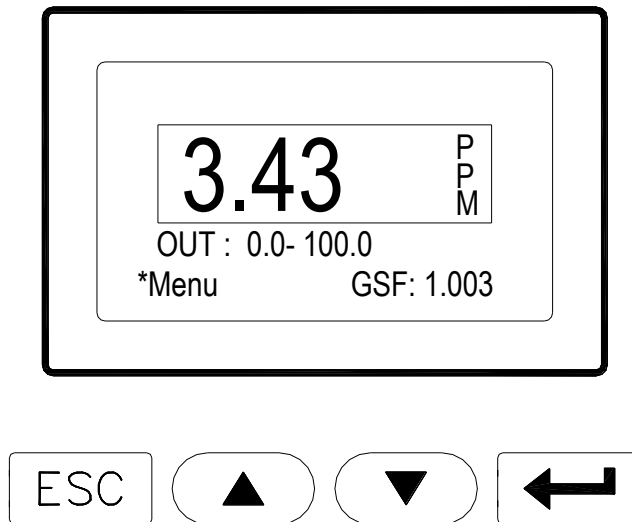

Figure 32: Data Display and Keypad

The numerical information shown is representative. Different values will probably be observed on the display.

There are four pressure sensitive keys below the display. The keys are used as follows:

ESC - Returns the display to the previous screen, or may be used to move to the left when within a data field selection.

▲ - Scrolls up in a menu or data selection.

▼ - Scrolls down in a menu or data selection.

← - Accepts the selected (asterisk) entry, allows data field selection, and may be used to move to the right when within a data field selection.

The **Annunciator Line** provides information about the status of the Analyzer, and alarm conditions. The Annunciator Line is displayed on the Main Menu Screen.

The **Data Line** indicates the measured oxygen concentration (e.g. 3.43 ppm). In this manual all concentrations will be shown in ppm O₂. For instruments that display data in percent (%) O₂ all actions are identical, but engineering units will be reported in percent (%).

Below the Data Line is a display of the **Analog Output Range** settings. The analog outputs are scaled over the range displayed in this area. Factory standard analog outputs are 0-10 VDC and Isolated 4-20 mA. Setting the analog voltage output is described on page 70. If the Analyzer is equipped with the Expanded Range Scale option the Analog Output Range value will change from OUT: x-xxxx to XPOUT: x-xxxx, and will appear in reverse video, when the expanded range scale is active.

* **Menu** indicates that if  is pressed, the Main Menu display, Figure 33, will appear.

GSF indicates the present Gas Scale Factor. The Gas Scale Factor is described on page 74. If the Analyzer is not equipped with the GSF option, or if N₂ is selected from the GSF table, then no GSF is displayed.

The legend "**OVER RANGE**" will overwrite the Oxygen display if the instrument analog to digital converter reads a value which is over its full scale range. During an over range condition the oxygen information is not valid. The analog output will be at maximum (pegged). An "OVER RANGE" condition will result in a continuous alarm tone, which may be silenced by pressing ESC.

The legend "**SENSOR OFF!**" will overwrite the Oxygen display if the sensor polarization voltage is turned off by using the Sensor selection in the Controls menu. The polarization voltage will automatically turn off if the Analyzer is OVER RANGE for more than 30 minutes. When the sensor is off the analog output falls to zero volts and the 4-20 mA output falls to 4 mA. An optional relay may be configured to indicate that the sensor is off. A "SENSOR OFF !" condition will result in an intermittent alarm tone, which may be silenced by pressing ESC. NOTE: The automatic sensor off function is disabled if the display is not in the main O₂ readout mode.

A reverse video overlay will appear over the center of the display for the following alarms: Oxygen (1,2,3,4), Temperature (T), Flow (F), and Electrolyte Condition (E). The overlay appears and disappears at intervals so that the Oxygen reading is still visible. If there are several alarms in progress all of the alarm overlays will be displayed in sequence.

The overlay also indicates the set point value and whether the alarm condition is a high or low alarm. If the alarm is a Flow or Electrolyte Condition alarm the set point is not displayed because these alarms do not have set point values. Audible annunciation can be activated for each of the alarms. If annunciation is activated, a continuous tone will occur when the overlay is displayed. Pressing ESC while the overlay is displayed will silence the tone and cause the overlay to disappear. Once an alarm has been acknowledged (by pressing ESC) its number will be continuously displayed in the Data Display Window on the Annunciator Line. The numbers are assigned as follows:

The alarm number will clear only after the alarm condition is over.

In the case of simultaneous alarms, each will alternately overwrite the display. Successive presses of ESC (as the overwrite is displayed) are necessary to clear the overwrite and

annunciation. This will not clear the alarm. Only a restoration of the condition that existed prior to the alarm will clear the alarm.

| Alarm Number | Function |
|--------------|-----------------------|
| 1 | Oxygen 1 |
| 2 | Oxygen 2 |
| 3 | Oxygen 3 |
| 4 | Oxygen 4 |
| T | Temperature |
| F | Flow |
| E | Electrolyte Condition |

Table 12: Alarm Identification

There are also a number of special messages that can appear on the Annunciator Line of the display:

CHECK FLUID – Indicates that a user set time period has expired after which the electrolyte level should be checked and Replenishment Solution should be added if necessary.

TEMP OVER RANGE - Indicates that the sensor temperature is over 50EC or that the temperature probe is disconnected. This alarm results in a continuous tone that may be silenced by pressing ESC.

UNDER RANGE - Indicates that the oxygen level is below the calibrated zero.

UNCALIBRATED - Warns that the Analyzer is not calibrated, or that NOVRAM data has been corrupted.

If there is an acknowledged alarm indicated in the Annunciator Line, special messages will appear in the upper left corner of the oxygen display box. Temp Over Range will show **TO**, and Under Range will show **UR**.

EXT SENSOR! Indicates that the oxygen sensor polarization voltage has been turned off remotely.

EXT PUMP Indicates that the pump has been turned on remotely.

Other possible messages, that may appear on various screens, include “**Wait!**”, and “**Memory Error!**”. “**Wait!**” indicates that the instrument is performing an operation that is time consuming (> 10 seconds), such as an internal electrical zero calibration. “**Memory Error!**” indicates that the instrument has failed the boot-up memory test. The letters “**CHG**”, “**BAT**” and “**LOW**” may appear vertically on the right side of the display on units equipped with the NiMH battery backup option.

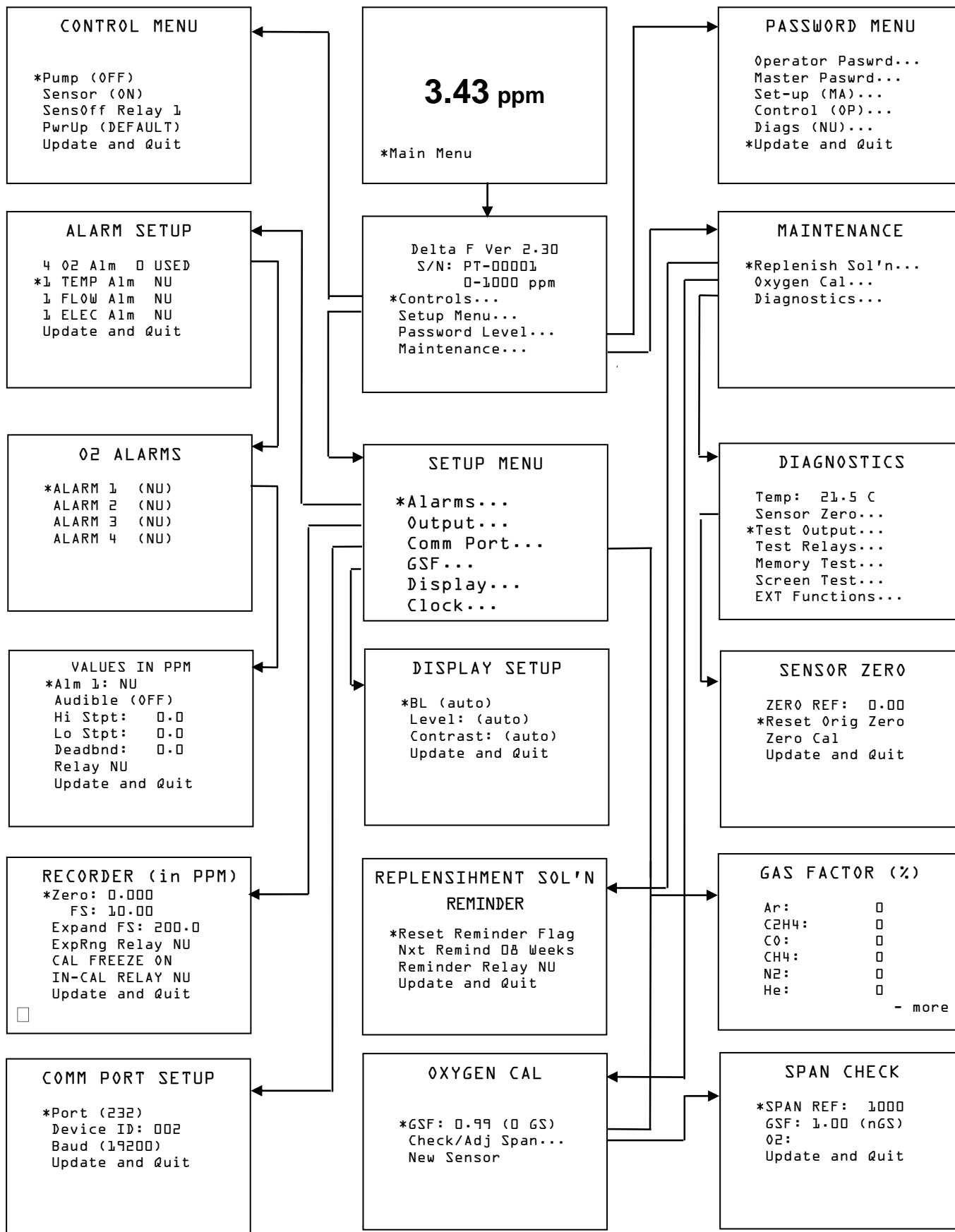

8.2 Main Menu

The Main Menu, Figure 33, is accessed by pressing  from the Data Display Window. Alarm Overlay information will continue to display over the Main Menu.

```
DELTA F Ver 2.40
S/N: PT-10396
      0-10000 PPM

* Controls...
  Set-Up Menu...
  Password Level...
  Maintenance...
```

Figure 33: Main Menu

The first three lines of the Main Menu display the firmware version, followed by the instrument serial number and the range of the Analyzer.

Four screens can be accessed from the main screen:

Controls - Used to turn on the pump, the sensor voltage, choose sensor off relay, and select power up default conditions for the above functions. See page 65.

Set-Up Menu - Used to set alarm parameters, the recorder output level and functions, configure communication port, to enter the gas scale factor, to perform or check the span calibration, or to install a replacement sensor. See page 67.

Password - Used to set passwords and indicate which menus are "password" protected
76

Maintenance – Used to access three screens related to replenishment solution addition, oxygen calibration and diagnostics.

The diagram on the previous shows the "Menu Tree" for the operator interface. Sufficient detail is provided to orient the user during instrument set-up; however, not all the program details are illustrated in this diagram.

Each level in the Main Menu allows the user to access options for setting and testing instrument parameters. Ellipsis (...) after an entry indicates that additional screens follow.

8.2.1 Keypad Operation

The following protocols are used to operate the Analyzer through the front keypad:

To access a level, use the ▲ or ▼ key to move the asterisk (*) to the desired level and press ←.

To edit a numerical value, use the ← key to highlight (reverse video) the digit to be changed. Successive use of the ← key will highlight the digits on a left to right basis. Use of the ESC key will move the highlighting back to the left and eventually cancel any adjustment. The rightmost digit will be the active digit for editing. Use ▲ or ▼ to adjust the desired value. After the desired numerical value has been entered, press the ← key until the number no longer appears in reverse video.

The ESC key is used to return to the previous screen without changing any parameters that may have been altered. If any parameters have been edited without updating memory, the display will present the message "ABANDON CHANGES?, ← FOR YES". All parameter changes will be **lost** if the ← key is pressed.

Select the UPDATE & QUIT choice using ← to save the changes and automatically return to the previous menu.

8.3 Controls Menu

The Controls menu is used to turn on or off a number of optional features of the Oxygen Analyzer. When the Controls menu is selected, and the appropriate password is entered (if required), the display will show Figure 34.

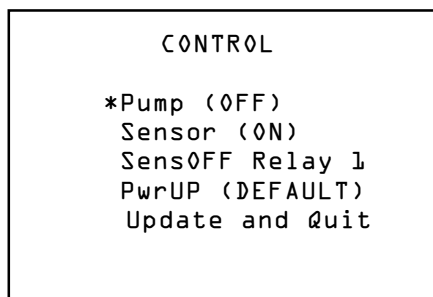



Figure 34: Controls Menu

8.3.1 Pump

(Optional) - After accessing the Pump entry, the pump is toggled ON or OFF by pressing . If the Analyzer does not have a pump, **NA** will be displayed.

See the section on ESC, page 67, for additional information about leaving the menu after changing the Pump setting.

See the section on Remote Controls, page 47, for additional information on remote control of the pump.

NOTE



Analyzers with pumps are fitted with a valve on the rotameter (downstream of the sensor) and a valve on the sensor inlet (upstream of the sensor). When using a pump to draw a gas sample at less than 0.2 psig, the downstream rotameter valve is used as the flow control valve. The sensor inlet (upstream) valve is shipped from the factory in the fully opened (counter-clockwise) position. Its position should not be changed unless the Analyzer is operated on positive pressure, e.g., when measuring a sample greater than 0.2 psig (but less than the maximum limit of 10 psig) that is vented to atmosphere. Likewise, when operating with a positive pressure the rotameter (downstream) valve should be fully opened and the upstream flow control valve used for flow control.

FAILURE TO FOLLOW THESE INSTRUCTIONS MAY CAUSE THE SENSOR TO EXPERIENCE OVER OR UNDER PRESSURE WHICH MAY CAUSE PERMANENT DAMAGE.

8.3.2 Sensor Polarization

After accessing the Sensor entry, the sensor power is toggled ON or OFF by pressing . The sensor ON command applies a polarizing voltage to the sensor. See the section on ESC, page 67, for additional information about leaving the menu after changing the Sensor setting.

The Analyzer has been programmed to protect the sensor from extended operation in an over-range condition (> 30 minutes). If such a condition exists, the software will turn off the polarizing voltage to the sensor. A message will be displayed indicating that the sensor has been turned off, and an intermittent beep will occur as in Figure 35. The beep can be silenced and message canceled by pressing ESC. When ESC is pressed a reverse video SENSOR OFF! legend will overlay the oxygen display.

The user should investigate the reason for the excessively high O₂ level, remedy the situation, and then restore power to the sensor via the Controls menu. The oxygen value is approximately zero when the sensor is off. Also, the analog outputs will go to zero, so any low Oxygen alarms set above zero will trigger on.

NOTE: The automatic sensor off function is disabled if the display is not in the main O₂ readout mode.

See the section on Remote Controls, page 47, for additional information on remote control of the sensor polarization voltage.

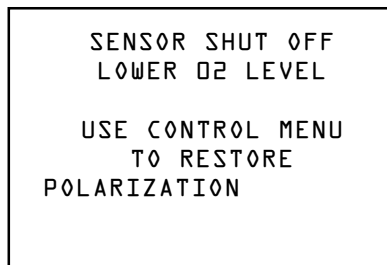

Figure 35: Sensor Shut-off Warning

8.3.3 SensOFF Relay

When the sensor is manually turned off from the front panel, or automatically turned off because the instrument has been over-range for more than 30 minutes, a relay may be assigned to signal that the sensor is off. This feature is important when the Analyzer is used in an unattended area, so that a remote operator can be notified that the instrument is no longer measuring oxygen. If the instrument is not equipped with any relays this selection will show **NA**. It is possible to assign more than one alarm or status condition to any relay. Since the status condition of the sensor, being switched off, signifies an “Analyzer Off-line” condition, it is important to make sure that the relay assigned to SensOFF service is only assigned to alarm conditions signifying similar levels of alert, such as a Low Flow Alarm.

Note: Alarm or Analyzer status conditions that signal an “Analyzer off-line” fault condition (such as sensor off) can be assigned to a single relay contact used as a trouble indicator. If the Analyzer signal is only monitored remotely, it is suggested to route the 4-20 mADC signal through the “**Analyzer Trouble**” relay such that an alarm condition will cause the relay to break the current loop. This method allows a computerized system to be configured to detect an analyzer fault condition whenever the 4-20 mADC signal is below 4 mA.

8.3.3.1 Sensor Off 4-20mA Signal

If configured at the time of order, the 4-20mA output can be reduced to 2mA when the Sensor is either manually or automatically turned off. See page 25 for additional information on the 2-20mA option.

8.3.4 P(o)w(e)r UP

When the Analyzer is powered down, and then turned back on, the pump controls default to OFF, and the Sensor defaults to ON. This activity is the DEFAULT operational mode of the pump and sensor. Instead, it is possible to store the states of the pump and sensor every time they change and allow the LAST state to be reestablished when the Analyzer is powered up. The selection “PwrUP” toggles between “DEFAULT” and “LAST”.

8.3.5 ESC

If only the Pump, or Sensor selection has been changed, and the PwrUP selection is set to DEFAULT, the Controls menu may be exited with ESC. The new changes will be in effect. If SensOFF Relay or PwrUP has been changed, and the changes are to be stored, or the PwrUP selection is set to LAST, the menu should be exited by selecting Update and Quit. If the changes are to be discarded press ESC. The Analyzer will present the message “**ABANDON CHANGES?, ← FOR YES.**” Press enter and the display will return to the Data Display Screen.

8.4 Set-Up Menu

Note: When the Set-up entry is selected from the Main Menu, a **DISABLING ALARMS** message appears which notifies the user that the alarms have been temporarily disabled. The alarm overlay messages will not show in the display. **Relays will remain in the alarm state that immediately preceded the Disabling Alarms message.**

The Set-Up Menu is used to establish a variety of Analyzer parameters. When the selection is made from the Main Menu, Figure 33, and the appropriate password is entered (if required), Figure 36 is shown.

```
      SETUP MENU

*Alarms...
  Outputs...
  Comm Port...
  GSF...
  Display...
  Clock...
```

Figure 36: Setup Menu

Each entry in Figure 36 leads to a sub-menu. To select the desired sub-menu, use the ▲ and ▼ keys to place the asterisk next to it, then press ←. A new display will be shown as indicated below.

8.4.1 Alarms

The Alarms screen is used to set or determine the status of alarms. When the Alarms entry is selected from Figure 36, the display will present Figure 37.

```
ALARM SETUP
* 4 O2 Alm 0 USED
  1 TEMP Alm NU
  1 FLOW Alm NU
  1 ELEC Alm NU
Update and Quit
```

Figure 37: Alarm Setup Menu

To select an alarm to edit, use the ▲ and ▼ keys to move the asterisk. Press ← when the alarm is indicated. If (NA) is displayed next to any entry, that alarm option is Not Available.

8.4.1.1 O₂ Alarms

If an O₂ alarm has been selected from the Alarm Setup Screen Figure 37, the display will show Figure 38.

```
O2 ALARMS
* ALARM 1 (NU)
ALARM 2 (NU)
ALARM 3 (NU)
ALARM 4 (NU)
```

Figure 38: Oxygen Alarm Menu

```
Values In PPM
* Alm 1: NU
Audible (OFF)
Hi Stpt:    0.0
Lo Stpt:    0.0
Deadbnd:    0.0
Relay NU
Update and Quit
```

Figure 39: Oxygen Alarm Setup Screen (Alarm not used)

After selecting an Alarm with the ▲ and ▼ keys, use ← to toggle the alarm On (USED) or Off (NU). When an unused alarm (NU) is accessed, the display will appear as shown in Figure 39. (Oxygen ALARM 1 is used in the example shown in Figure 40.) To indicate that the alarm is

to be used, move the asterisk to Alm 1 and press . For the oxygen alarms, the **NU** will change to **O2**.

Audible is used to toggle On or Off the audible alarm feature. The **Hi Stpt** (high set point) and **Lo Stpt** (low set point) refer to the limits above and below which the alarm will be triggered.

Each oxygen alarm (and the temperature alarm) can be set for a high trip point and a low trip point. This feature gives the user the ability to operate the process between limits of high and low O₂ concentration (or temperature range) using only one alarm.

Deadband refers to how far the current value must be above (for lo alarms) or below (for hi alarms) the set point before an alarm is reset. For example, for a High Alarm (Hi Stpt) set to 50 ppm, a Low Alarm (Lo Stpt) set to 30 ppm, and the deadband (Deadbnd) set at 5 ppm, the alarm will trigger at 50 ppm. The alarm will continue to report until the oxygen concentration falls below 45 ppm (Set point minus Deadband). At 45 ppm, the alarm will reset.

With the Low Alarm, the alarm would trigger at 30 ppm and continue to report until the O₂ concentration increased to 35 ppm (Set point plus Deadband). At 35 ppm the alarm would reset.

Relay indicates the relay to which the alarm is assigned. The options are NU (not used), 1, 2, 3 or 4. Each relay can be assigned up to seven alarms. If more than one alarm is assigned to a relay, any assigned alarm will trip the relay, and the relay will remain tripped until ALL alarms assigned to it are cleared. The alarm can be assigned to only one relay.

If an active alarm is accessed, the display will indicate the present values. An example of an active alarm (O₂ Alm 1) is shown in Figure 40.

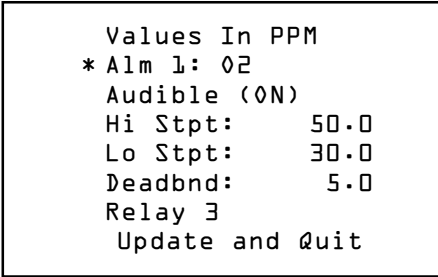

```
Values In PPM
* Alm 1: O2
Audible (ON)
Hi Stpt:    50.0
Lo Stpt:    30.0
Deadbnd:    5.0
Relay 3
Update and Quit
```

Figure 40: Oxygen Alarm Setup Screen (Alarm used)

8.4.1.2 Temperature Alarm

The **TEMP** alarm is used to indicate an out of range temperature condition for the sensor. From the Alarm Setup Menu, Figure 37, selecting TEMP Alm (ON) will bring a display similar to Figure 39. The alarm can be assigned to any one relay.

The temperature alarm is programmed in the same way as an O₂ alarm. The temperature alarm cannot be set to a value greater than 45 Deg. C. It is recommended that the High Set point be set at 40 Deg. C.

8.4.1.3 Low Flow Alarm

The **FLOW** alarm is used to indicate a low flow condition in the sample stream. The optional low flow switch will trip if the gas flow rate drops below the value listed in Table 13.

| Background Gas | Trip Point (scfh) |
|-----------------|-------------------|
| Air | 0.25 |
| Ammonia | 0.33 |
| Argon | 0.22 |
| Butane | 0.18 |
| Carbon Monoxide | 0.26 |
| Ethane | 0.25 |
| Ethylene | 0.26 |
| Helium | 0.69 |
| Hexane | 0.15 |
| Hydrogen | 0.96 |
| Methane | 0.34 |
| Nitrogen | 0.26 |
| Propylene | 0.21 |

Table 13: Flow Switch Trip Points

From the Alarm Setup Menu, Figure 37, selecting FLOW Alm (ON) will bring a display similar to Figure 39. The alarm can be assigned to any one relay.

The flow alarm is programmed in the same way as an O₂ alarm. However, the values for Hi Stpt, Lo Stpt and Deadbnd will indicate **NA**. These values cannot be accessed.

8.4.1.4 Electrolyte Condition Alarm

The **ELEC** alarm is used to indicate electrolyte condition. From the Alarm Setup Menu, Figure 37, selecting the ELEC Alm (ON) will bring a display similar to Figure 39. The alarm can be assigned to any one relay.

The electrolyte condition alarm is programmed in the same way as an O₂ alarm. However, the values for Hi Stpt, Lo Stpt and Deadbnd will indicate **NA**. These values cannot be accessed.

8.4.2 Analog Outputs

The **Outputs** entry in the Setup Menu, Figure 36, is used to scale the full range of the analog output (voltage and current) over a partial or full range of oxygen concentration.

NOTE: Alarm or Analyzer status conditions that signal an “Analyzer off-line” fault condition (such as sensor off) can be assigned to a single relay contact used as a trouble indicator. If the Analyzer signal is only monitored remotely, it is suggested to route the 4-20 mADC signal through the “Analyzer Trouble” relay such that an alarm condition will cause the relay to break the current loop. This method allows a computerized system to be configured to detect an analyzer fault condition whenever the 4-20 mADC signal is below 4 mA. After accessing the Outputs on the Setup Menu, Figure 36, the display will be as shown in Figure 41.

```

RECORDER (in PPM)
*Zero: 0.000
  FS: 10.00
Expand FS: 200.0
ExpRng Relay NU
CAL FREEZE (ON)
IN-CAL RELAY NU
Update and Quit

```

Figure 41: Recorder Output Setup Menu

From the Recorder Outputs menu, the recorder zero and full scale (FS) can be set. On Trace Analyzers, the values are in ppm; on Percent Analyzers, the values are in %. The selected Zero and FS values will be displayed underneath the oxygen reading in the Data Display Screen. The Zero value corresponds to the lowest possible voltage and current output (0 VDC, 4 mA), while the FS (Full Scale) value corresponds to the maximum voltage and current output (5 or 10 VDC [see Section 4.6] and 20 mA).

8.4.2.1 Scaling Analog Output Range On Standard Resolution Analyzers

The Zero to Full Scale window (FS setting - Zero setting) can be as narrow as 10% of the Analyzer's full scale range. This limit is based on the fact that oxygen information is in a digital format. Like a digital photograph it is only possible to magnify the information so much before there isn't enough resolution and the result is too grainy to use. Analyzers are shipped with a factory setting that corresponds to the full scale range of the Analyzer. For example, a 0-100 ppm Analyzer on first power-up would show OUT: 0.0-100.0 underneath the oxygen reading in the Data Display Screen. Following are examples of valid recorder output settings on a 0 – 100 ppm standard resolution analyzer.

| Output (Zero to FS) | Percentage of scale used on a 0 – 100 ppm standard resolution analyzer |
|---------------------|--|
| 0-10 ppm | 10 % of Scale |
| 20-40 ppm | 20 % of Scale |
| 10-50 ppm | 40 % of Scale |
| 0-100 ppm | 100 % of Scale |
| 50-85 ppm | 35 % of Scale |

Table 14: Output Scaling on Standard Resolution Analyzer

If an invalid Zero to FS window is entered the following error message will be briefly displayed.

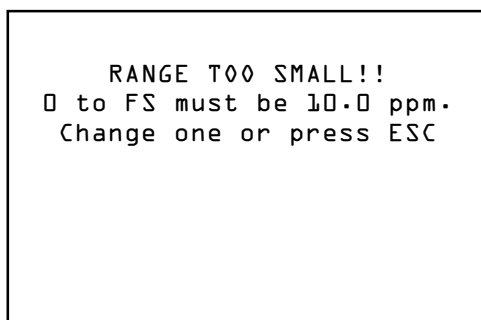

Figure 42: Recorder Output Setup Error

8.4.2.2 Scaling Analog Output Range On High Resolution Analyzers

On High-Resolution Analyzers the instrument has two internal operating ranges: 0-10% of full scale (Scale A) and 0-100% of full scale (Scale B). When the oxygen reading decreases below 10% of full scale the analyzer automatically increases its internal gain by a factor of ten by switching to Scale A. This gain increase permits the front panel oxygen display to provide an additional digit of displayed resolution. Refer to the section on Specifications page 9, for a list of displayed resolutions. The increased gain also permits the analog output scaling to be set for from 10% to 100% of Scale A, in addition to 10% to 100% of Scale B. See Table 15 for details. Using the High-Resolution model is preferred if the oxygen reading will usually be below 10% of the analyzer full scale reading and small changes in concentration (0.1% of full scale) must be detectable. The selected Zero and FS values will be displayed underneath the oxygen reading in the Data Display Screen. Following are examples of valid recorder output settings on a 0 – 100 ppm high resolution analyzer.

| Output (Zero to FS) | Percentage of scale used on a 0 – 100 ppm high resolution analyzer |
|---------------------|--|
| 0-1 ppm | 10 % of Scale A |
| 2-4 ppm | 20 % of Scale A |
| 1-5 ppm | 40 % of Scale A |
| 0-10 ppm | 100 % of Scale A |
| 0-20 ppm | 20 % of Scale B |
| 20-40 ppm | 20 % of Scale B |
| 10-50 ppm | 40 % of Scale B |
| 0-100 ppm | 100 % (Factory Set) |
| 50-85 ppm | 35 % of Scale B |

Table 15: Output Scaling on High Resolution Analyzer

8.4.2.3 Expanded Range Scale Operation And Setup

The optional expanded range scale function allows the analog output scaling to be automatically expanded to a larger value when the primary scaling range is exceeded. For example, in the display shown in Figure 41, the analog outputs (0-10 VDC and 4-20 mA) are scaled over the 0 -

10.00 ppm area. However, the Analyzer is a 0-500 ppm unit and if the oxygen value exceeds 10.00 ppm the analog output will peg. With the expanded range option it is possible to set a larger ppm range that will automatically rescale the analog output when the primary scale is exceeded. In the example, the analog output is scaled over 0 - 200 ppm as soon as 10.00 ppm is exceeded. If the oxygen level falls, the Analyzer will switch back to the original 0 - 10.00 ppm scaling as soon as the value is below 95% of the primary scale (9.5 ppm). This scaling change only affects the analog outputs.

When operating on the expanded range the analog output scaling information on the front panel will change to:

XP0UT: 0.0 - 200

When the asterisk is on the Expand FS line, each time the  key is pressed a different full scale value will appear. In this way it is possible to scroll through a list of selections. The expanded range full scale value must be larger than the normal FS value, or the Analyzer will not accept the setting. Expanded range may be turned off at any time by setting Expand FS to NU. The zero point setup on the primary range is also used when operating on the Expanded Range.

8.4.2.4 ExpRng Relay

An alarm relay may be assigned to indicate when the optional expanded range is in effect. The relay will be in the “Normal” state when the analog output is on the primary range scale, and will switch to the “Alarm” state when the expanded range scale is in effect. If there are no relays installed this option will show **NA**. Since it is possible to assign more than one alarm or status condition to any alarm relay, it is important to ensure that there are no other items assigned to this chosen relay unless it is really desired.

8.4.2.5 CAL FREEZE

When a zero or span calibration is started CAL FREEZE holds the analog output at the last valid oxygen value prior to the calibration. The oxygen value remains held until the calibration is completed. This feature prevents a PLC or data acquisition system from “Seeing” a calibration. If the PLC is used to detect alarms, a calibration could involve sampling gas sources with concentrations above process alarm set points. CAL FREEZE may be turned off so that the analog output operates normally (follows the oxygen value) during calibration.

8.4.2.6 IN-CAL RELAY

This is a setup feature that allows an optional alarm relay to be assigned to indicate when the instrument is in the zero or span calibration mode. This feature may be used to signal a PLC, DCS or other external device when the instrument is in calibration (not sending “Process” O₂ data). Any relay may be assigned to IN-CAL RELAY service. If the Analyzer is not equipped with relays, this selection will be **NA**. Since it is possible to assign more than one alarm or status condition to any alarm relay, it is important to ensure that there are no other items assigned to this chosen relay unless it is really desired.

8.4.3 Comm Port

The Comm Port Menu, selected from the Setup Menu Figure 36, is used to edit information about the external communications port. This port operates with an 8 bit, no parity, one stop bit setting. No hardware or software handshaking is used. See the Section on Connecting to External Devices on page 43 for more information.

After accessing the Comm Port Menu, the display in Figure 43 will be shown.

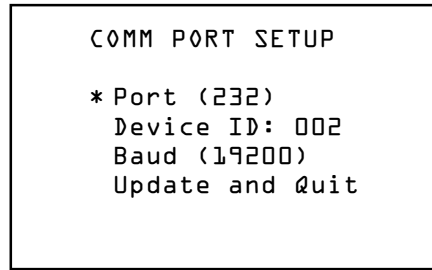

Figure 43: Comm Port Setup Menu

8.4.3.1 Port

Used to indicate if the data should be sent to the RS-232C port (232), the RS-485 (485) port or no communication port (OFF). Optional hardware must be factory installed to support either port option. It is not possible for the analyzer to be equipped with both the RS-232C and RS-485 option.

8.4.3.2 Device ID:xxx

Device ID is used to indicate the identity of the Analyzer. When using multiple Analyzers on an RS-485 loop the device ID is used as a unique address which allows Analyzers to be individually contacted by the communication software. The device number can be edited. The valid ID address range is 1 to 255. Even when equipped for RS-232 (one host communicating with one analyzer) it is necessary to set a valid ID address for the analyzer. The communication protocol uses the ID address as part of the data packet sent to the analyzer.

8.4.3.3 Baud

This setting is used to choose the data transmission rate. The options are 19200, 9600, 4800, 2400 or 1200. The Analyzer is capable of receiving 19200 Baud transmissions without requiring hardware or software handshaking. It is suggested that the highest data rate be used that reliably works in the application. In this way the system will be as responsive as possible.

8.4.3.4 Update And Quit

Update and Quit is used to accept the values set on this screen.

8.4.4 Gas Scale Factor

Refer to the section on Calibration on page 79.

8.4.5 Display Setup

Access to the controls related to the backlight, brightness and contrast of the display are gained through the display setup menu. See Figure 44 below.

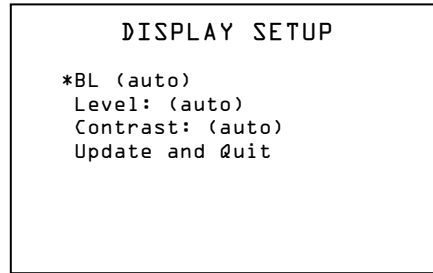

Figure 44: Display Setup

8.4.5.1 Backlight (BL)

Access to the control of the backlight function is gained through the Display Setup menu. Hitting the Enter key while the BL option is highlighted will toggle through three backlight options: on/off and auto. When the desired setting is highlighted, move to the update and quit option with the ▲ and ▼ keys and then hit enter. If auto is selected, the display backlight is turned on by a front panel key stroke and runs for 30 seconds after the last key activity. If equipped with a NiMH battery option, the backlight will only stay on for 10 seconds if the analyzer detects a low battery condition.

8.4.5.2 Level

Access to the control of the level or brightness function is gained through the Display Setup menu. Hitting the Enter key while the Level option is highlighted will toggle through four brightness options: low/mid/high and auto. When the desired setting is highlighted, move to the update and quit option with the ▲ and ▼ keys and then hit enter.

8.4.5.3 Contrast

Access to the control of the contrast function is gained through the Display Setup menu. Hitting the Enter key while the Contrast option is highlighted will toggle through four contrast options: low/mid/high and auto. When the desired setting is highlighted, move to the update and quit option with the ▲ and ▼ keys and then hit enter.

8.4.6 Clock

The Clock Menu, selected from the Setup Menu Figure 36, is used to edit information regarding the clock and calendar operation. After accessing the Clock menu, Figure 45 appears.

To set the current time, use the ▲ and ▼ keys to move the asterisk to Time. Press ← and the cursor will highlight the hours. Use the ▲ and ▼ keys to set the hours, press ← to move to the minutes and after setting the minutes move to and set the seconds.

To set the current date, use the ▲ and ▼ keys to move the asterisk to Date. Press ← and the cursor will highlight the day. Use the ▲ and ▼ keys to set the day, press ← to move to the month and after setting the month move to and set the year.

When complete, move to the update and quit option with the ▲ and ▼ keys and then hit ← enter.

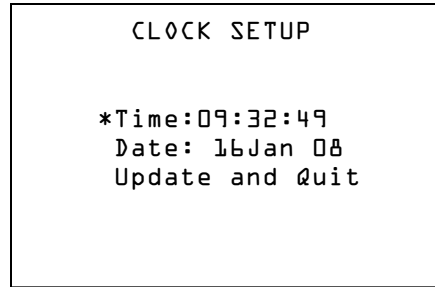

Figure 45: Clock Setup Screen

8.5 The Password Menu

The DF-310E Process Oxygen Analyzer may include optional password protection which can be used to limit access to the Control Menu, the Set-Up Menu, and the Diagnostics Menu.

Note: When the Password entry is selected from the Main Menu, a **DISABLING ALARMS** message appears which notifies the user that the alarms have been temporarily disabled. The alarm overlay messages will not show in the display. **Relays will remain in the alarm state that immediately preceded the Disabling Alarms message.**

The password operates on two levels, a Master Password to establish overall control of the system, and an Operator Password to allow partial access to the system. If the selected level requires a password, the display will present a password prompt. The password menu is displayed in Figure 46.

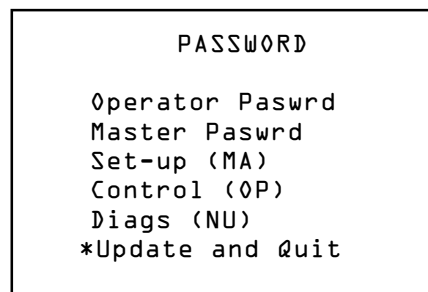

Figure 46: Password Menu

The two-letter codes adjacent to the **Set-Up**, **Control** and **Diags** entries in the display are used to indicate the level of password that is required to access the Set-Up, Controls or Diagnostics menus. There are three possible settings for each entry:

MA (Master) - Indicates that the master password must be used to access the menu.

OP (Operator) - Indicates that the operator password or master password can be used to access the menu.

NU (Not Used) - Indicates that no password is required to access the menu.

Note: When an Analyzer is shipped from the factory no password is installed.

To enter an Operator Password or Master Password, select the desired level. The display for an operator password is shown in Figure 47. The display for a master password is identical except the bottom line is blank instead of OP:.

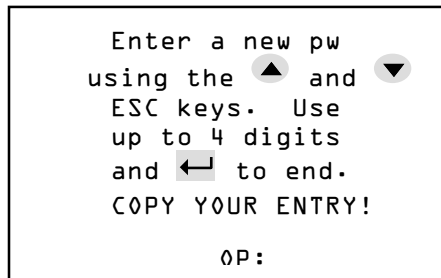

Figure 47: Password Entry Screen

A password consists of a series of one to four keystrokes using the ESC, ▲ and ▼ keys. Password entry is completed by pressing ↵. Any combination of these keystrokes is acceptable. A typical password is ▲, ESC, ▼, ▼. After the fourth key is pressed in the Operator's Password, the display will automatically return to the Password Menu, Figure 46. After the fourth key is pressed in the Master's Password, press ↵ to return to Figure 46.

NOTE



The master password should be recorded in a secure location. Once the master password has been accepted, the Analyzer will not display it again. If the master password is misplaced, contact the local Servomex Business Center.

The master password and operator password can be changed as desired after the present master password has been entered. The new password(s) are activated by pressing ↵ when the asterisk is at **Update and Quit**.

To password protect a menu item (Set-Up, Control, Diags) use the ▲ or ▼ key to place the asterisk next to the item and press ↵. Subsequent pressing ↵ will cycle through **NU**, **OP**, and **MA**. When the passwords and the settings for all three menus have been set, select **Update and Quit**.

8.6 Maintenance

Note: When the Maintenance entry is selected from the Main Menu, a **DISABLING ALARMS** message appears which notifies the user that the alarms have been temporarily disabled. The alarm overlay messages will not show in the display. **Relays will remain in the alarm state that immediately preceded the Disabling Alarms message.**

The Maintenance Menu is used to access the Replenishment Solution Addition Reminder, Oxygen Calibration and Diagnostics Screens. When selected from the Main Menu, Figure 33, the display shows Figure 48.

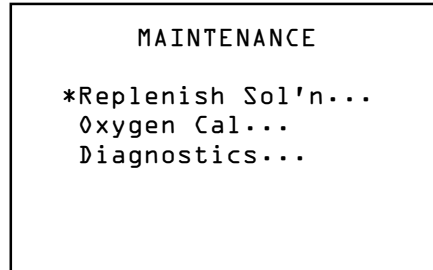

Figure 48: Maintenance Menu

8.6.1 Replenish Solution Reminder

The Replenish Solution Reminder screen Figure 49 is accessed from the Maintenance Screen Figure 48 and refers to the electrolyte level in the Oxygen Sensor. It is used to reset the refill reminder flag, set the reminder frequency and to assign a relay to the Reminder Warning.

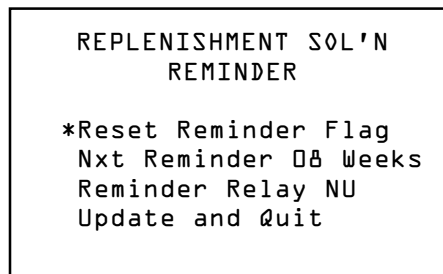

Figure 49: Replenishment Solution Reminder

8.6.1.1 Reset the “Reminder” Flag

If the Check Fluid flag is displayed on the Data Display Screen, the first line of the Reminder Screen allows this flag to be cleared or reset after Replenishment Solution has been added to the oxygen sensor. Use the ▲ and ▼ keys to move the asterisk next to Reset Reminder Flag and press ←. Then move the asterisk down to Update and Quit and press ← again to confirm the reset action. Or, pressing ^{ESC} at this point will result in the question “Abandon Changes? ← for yes” and the user can press ← to return to the Maintenance Menu, Figure 48.

8.6.1.2 Set the “Reminder” Flag Frequency

The Maintenance Screen allows the period of time between Replenishment Solution additions to be automatically tracked by the analyzer. When the time period ends, the Check Fluid flag shows on the Data Screen, reminding the user to refill the electrolyte level with Hummingbird Replenishment Solution. The flag can be set from 0 - 12 weeks, in increments of one week. Note – the reminder frequency is pre-set at the factory to eight weeks.

8.6.1.3 Assign the “Reminder” Relay

The Reminder flag can be assigned to any of the available relays. See the section on relay assignment in the Oxygen Alarm section on page 68.

8.6.2 Oxygen Calibration

Analyzer calibration checks and adjustments are made from the Oxygen Cal Menu which is entered from the Setup menu, Figure 36. After accessing the Oxygen Cal Menu, the display will present Figure 50.

If the system has been previously recalibrated by the user, when the Oxygen Cal selection is made, an additional line will be added to the menu that states **Reset Orig Span**. The section on Maintenance and Calibration on page 93 provides more information about spanning the analyzer.

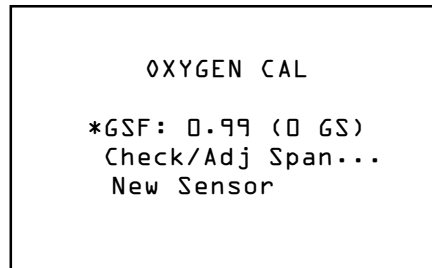

Figure 50: Oxygen Calibration Menu

8.6.2.1 Background Gas Correction (Optional)

The optional GSF (Gas Scale Factor) is used to correct for changes in the rate of oxygen diffusion when background gases other than nitrogen are present in the sample gas. The GSF menu can be entered through the Set Up Menu, Figure 36, or through the Oxygen Cal Menu, Figure 50. In many applications, the GSF is not required, i.e., GSF=1.00. However, for some background gases with significantly different diffusivities compared to nitrogen (such helium, hydrogen, or C₃ and heavier hydrocarbons), the GSF can be useful. To use GSF, enter the volumetric percentages of the sample gas as described below. The GSF is automatically calculated. Alternately, the GSF factor can be entered manually. The software in the Analyzer supports the following gases in the GSF calculation:

| | |
|-----------------|--------------------------------|
| Ammonia | NH ₃ |
| Argon | Ar |
| Butane | C ₄ H ₁₀ |
| Carbon Monoxide | CO |
| Ethane | C ₂ H ₆ |
| Ethylene | C ₂ H ₄ |
| Helium | He |
| Hexane | C ₆ H ₁₄ |
| Hydrogen | H ₂ |
| Methane | CH ₄ |
| Nitrogen | N ₂ |
| Propylene | C ₃ H ₆ |

Table 16: GSF Corrections

Contact the factory, for assistance with gases not listed above.

When **GSF** is selected, the display in Figure 51 will be shown.

| GAS FACTOR (%) | |
|----------------|---|
| Ar: | 0 |
| C2H4: | 0 |
| CO: | 0 |
| CH4: | 0 |
| N2: | 0 |
| He: | 0 |

Figure 51: Gas Scale Factor

Entries for additional gases can be accessed by using the ▲ or ▼ keys to scroll through the list. The entries spread across more than two screens. Continued pressing of ← will give access to the additional choices, shown in Figure 52. By moving the asterisk to the appropriate line and pressing ←, the volume percentage of the sample gas can be adjusted.

After the volumetric percent of the selected gas is entered, continue to press ← until the number is no longer in reverse video. Repeat the process for other gases in the sample gas composition. Note: An error message will appear if the sum of gases does not equal **100%**. If that occurs, change one (or more) values and press ← again.

For percent oxygen Analyzers, assume oxygen has the same diffusivity as nitrogen. Thus, add the percentage of oxygen to the percentage of nitrogen when entering the percentage of nitrogen.





At the bottom of the list, the display will show Figure 52 below.

| GAS FACTOR (%) | |
|-----------------|------|
| C2H6: | 0 |
| C3H6: | 0 |
| C4H10: | 0 |
| C6H14: | 0 |
| GSF: | 1.00 |
| Update and Quit | |

Figure 52: Gas Scale Factor Menu (Cont'd)

Note: Scrolling down the gas list from Figure 51 to Figure 52 will displace one line at a time. Because these figures are presented from the top and from the bottom of the gas list, H2 (Hydrogen) and NH3 (Ammonia) appear to be missing.

When the composition of the gas (or the GSF factor) has been entered move the asterisk to Update & Quit and press . The GSF will be calculated and displayed.

If the GSF factor of the gas used to calibrate the system is already known, it can be entered directly. To enter the GSF directly, move the asterisk to the **GSF** line and press . Use the  and  keys and hit  to enter the desired value.

NOTE



The GSF for the gas used to calibrate the system may be different from that used during analysis. If the GSF is changed to reflect the composition of the calibrating gas, be sure to reset the GSF before analyzing samples.

Disclaimer

The method used to correct the calibration of the Servomex Oxygen Analyzer for measurement in non-nitrogen background gases is derived from a well known theoretical mass transfer equation. This equation accounts for the change in oxygen diffusion rates through different gases.

Although significant empirical work has been done in this field, it is generally accepted that the equation may be only 85-90% accurate. In addition, there is further error introduced when correcting for a "multi" component background gas. This may result in an additional 3-5% error. Correcting the calibration (for all combinations of background gases) using theoretical means has its limitations.

An alternate method when using a non-nitrogen or "multi" component background gas is to obtain a certified oxygen calibration standard which has been prepared in a background gas which models the average process sample. In this case any possible error introduced in using the theoretically derived correction factor is eliminated. Caution must still be used, however, as certified standards may also have inaccuracies associated with them.

Questions regarding the calculation of a background gas correction factor for a specific application should be directed to the local Servomex Business Center.

NOTE: In light gas (H₂ or He) backgrounds, the diffusion rate of oxygen will be greater than that in nitrogen, resulting in a higher absolute current generated by the sensor. If the sample contains an oxygen concentration near the high-end of the instrument (e.g. 80 ppm on a 0-100 ppm unit), and consists of a light gas background, the current generated by the sensor may be too much for the electronics to source and will effectively put the instrument out of range. In such a case, it would be appropriate to use an analyzer of the next highest range (e.g. 0-500 ppm). Consult Servomex for application specific details.

8.6.2.2 Check/Adj Span

Note: A calibration should be performed only after the Analyzer has been operating at least eight hours. The door should be closed when calibrating the Analyzer to keep the sensor temperature stable.

It is not possible to perform a Span Adjustment if the TEMP OVER RANGE condition is occurring.

The **Check/Adj Span** entry in the Oxygen Cal Menu, Figure 50, is used to adjust the O₂ calibration. Selecting Check/Adj Span will display the screen shown in Figure 53.

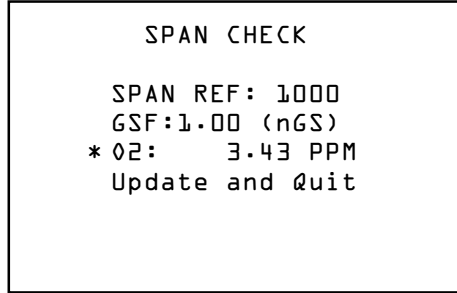

Figure 53: Span Check Menu

The GSF factor of the calibration gas can be entered directly or calculated by the instrument as described on page 79. The legend (nGS) indicates the number of gases used to calculate the GSF. If n has a value of zero, it indicates that the factor was directly entered, or the default value of GSF=1.00 was used.

The Span Reference value **SPAN REF** is a numerical indicator for calibration changes made in the field. All instruments are shipped from the factory with a SPAN REF value of 1000. The number will decrease if the sensor's output decreases and vice versa. For example: For a 100 ppm Analyzer if a 70 ppm span gas is being used, the Analyzer reads 65 ppm, and an Oxygen Cal is performed, the Span Reference will change to 928 ($[65 \text{ ppm} / 70 \text{ ppm}] \times 1000$) following the calibration process.

The following information should be recorded at each calibration:

- Date
- Span Gas Value
- Old Span Ref Value
- New Span Ref Value
- Time spent sampling Span Gas

Note: If the sensor has lost or gained significant sensitivity, verify the quality of the gas used as the calibration standard.

Review the section, Sampling Considerations During Calibration, on page 40 for information regarding calibration standards, regulators, purging, and sample conditions. When introducing a calibration gas into the sample system, it is important to maintain the same pressure and flow conditions that occur during process monitoring.

NOTE



Over-pressurizing the Analyzer can result in permanent damage to the sensor and optional pump. If the sample supply gas pressure exceeds 10.0 psig, install a pressure regulator in the inlet calibration gas line to regulate the pressure to 5.0 psig or less. The upstream flow control valve is used to set the flow at 1.0 (scfh).

If the normal process sample is being supplied to the Analyzer under moderate vacuum

conditions (4" Hg vacuum or higher), such as when taxing the capability of the on-board pump, the Analyzer should be calibrated with the pump operating even if the calibration gas has sufficient pressure to preclude the use of the pump. The operating pump will create a pressure condition at the sensor that simulates the operating condition.

Analyzers with a pump are fitted with two flow control valves, one on the downstream rotameter and one on the sensor inlet (upstream of the sensor). Before turning on the pump, open the rotameter valve fully by turning it counter-clockwise. Close the upstream flow control valve completely (clockwise). Set the calibration gas regulator to less than 10.0 psig, then attach the calibration gas line to the Analyzer inlet. Use the upstream flow control valve to set the flow rate to 1.0 scfh. Turn on the pump and readjust the flow rate prior to calibrating.

NOTE



Do not adjust the valve at the rotameter, leave it in the fully open position during calibration.

For an accurate calibration, the sensor output must be stable. The time to achieve stability depends on the range of the Analyzer and the difference between the sample gas value and the span gas concentration. Typically, lower ppm range instruments require more time to achieve a stable output than higher ppm or percent instruments. The use of a chart recorder is suggested to monitor stabilization.

NOTE



Time required for the O₂ reading to stabilize when on span gas can vary from 15 to 60 minutes.

After a stable reading is obtained, enter the O₂ concentration of the calibration gas. Then press  to complete the calibration.

A “Wait...” message will appear, followed by the display shown in Figure 54.

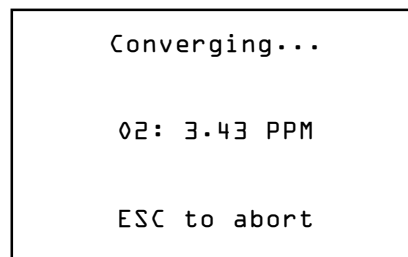

Figure 54: Calibration Convergence Screen

It may take several minutes before convergence occurs. During convergence, the Analyzer is verifying stability of the reading before accepting the data. After convergence two short beeps will be heard. The Analyzer's electronics can be updated to the new calibration information by selecting **Update and Quit**.

If convergence does not occur within 5 minutes, check the following:

- a. Make sure the gas connections are leak free.
- b. Make sure the sensor has been allowed sufficient time to have attained a stable reading on the calibration gas.
- c. Check the electrical connections to the sensor.

If all items check out, allow the Analyzer to operate an additional 30 minutes on calibration gas. Repeat the calibration. If the results are the same, acceptance of the calibration may be forced by the user by hitting the **←** key while in the “Convergence” screen. See Figure 54.

To leave the Calibration before completing convergence, press ESC. The previous calibration will remain in effect.

If the system has been recalibrated by the user, when the Oxygen Cal selection is made from the SETUP MENU the display will appear as shown in Figure 55. The number in parenthesis next to the GSF will indicate the number of gases used (4 **Gas**es in the representative screen) to calculate GSF, or it will indicate the chemical formula for a single gas used (such as **He**).

```
OXYGEN CAL
* GSF: 0.99 (4 GS)
Check/Adj Span...
New Sensor
Reset Orig Span
```

Figure 55: Completed Oxygen Calibration Menu

8.6.2.3 Reset Orig(inal) Span

The **Reset Orig Span** entry is used to restore the calibration that was made at the factory when the unit was manufactured, or the New Sensor calibration if the sensor has been field replaced.

If the **Reset Orig Span** entry is selected, the display will ask **Erase Cal?... ← FOR YES**. Press **←** to use the factory set calibration. The bottom line of Figure 55 will disappear, and the factory span calibration will be restored.

8.6.2.4 New Sensor

The **New Sensor** entry is used after a new sensor is field installed. New sensors are supplied with calibration information. The procedure for installing a new sensor is described in instructions supplied with it.

NOTE



Do not edit this entry without specific instructions from the Servomex Customer Support Services Department. Editing the entry will alter the stored factory calibration parameters and may cause dramatically erroneous operation. If the entry has been accidentally accessed, press ESC.

8.6.3 Diagnostics

Note: When the Diagnostics entry is selected from the Main Menu, a **DISABLING ALARMS** message appears which notifies the user that the alarms have been temporarily disabled. The alarm overlay messages will not show in the display. **Relays will remain in the alarm state that immediately preceded the Disabling Alarms message.**

The Diagnostics menu is used to test different functions of the Analyzer. When this menu is selected and the password is entered (if required), Figure 56 is displayed.

```
DIAGNOSTICS MENU
Temp: 21.5 C
Sensor Zero...
*Test Output...
Test Relays...
Memory Test
Screen Test
EXT Functions...
```

Figure 56: Diagnostics Menu

8.6.3.1 Sensor Temperature

The display will indicate the present sensor temperature. There is no user action with this selection. This value does not update continuously; it is the last temperature reading before entering the menu. To obtain a new temperature reading, leave and re-enter the Diagnostics menu. New temperature values are available every 60 seconds.

8.6.3.2 Sensor Zero

The Sensor Zero entry is used to calibrate the zero baseline level of the sensor. The sensor zero baseline is calibrated at the factory and should not require any adjustments or checking under normal operating conditions. See Section 8.1.1 for details on normal operating conditions. If operating outside normal operating conditions contact Servomex for an application specific recommendation on checking the zero of the instrument in the field.

Should Servomex recommend checking the zero baseline calibration of the Analyzer, the

following procedure can be followed: purge the sensor with gas that is free of O₂ until the output is stable. A suitable way to obtain an oxygen-free gas is to pass a pure grade of nitrogen gas through an oxygen purifier such as SAES MicroTorr™, Millipore Waferpure™ or Semigas Nanochem® resin purifiers. It is necessary to have a zero gas sample source that is assured to be at least one order of magnitude purer than the lowest resolution of the Analyzer.

Note: The difficulty in delivering a high quality zero gas to the Analyzer in the field can introduce significant error when attempting to zero calibrate the Analyzer. It is recommended that recalibration be done at the factory with its certified low ppb system. If checking zero calibration in the field, ensure that the gas system used to zero calibrate the Analyzer is leak-free by performing the low flow test described on page 97.

Reaching a stable zero for the lowest range Analyzer may require 24 hours or longer, even assuming that the Analyzer has been running continuously for several weeks on a process application where readings are near the detection limits of the Analyzer. It is recommended that a recorder be used to chart the zero point, especially for low trace units. When the Sensor Zero entry is selected, the display will present Figure 57.

```
SENSOR ZERO  
  
ZERO REF:  0.00  
Reset Orig Zero  
*Zero Cal  
Update and Quit
```

Figure 57: Sensor Zero Menu

8.6.3.2.1 ZERO REF

The **ZERO REF** value is a numerical indicator for calibration changes made in the field. All instruments are shipped from the factory with a ZERO REF value of 0.00. The number will become negative, following a user zero calibration, if the sensor zero is below the factory calibration and vice versa. This value should be recorded both before and after a Zero Calibration.

8.6.3.2.2 Reset Orig(inal) Zero

The **Reset Orig Zero** entry is used to restore the zero calibration that was made at the factory when the unit was manufactured, or the New Sensor zero calibration if the sensor has been field replaced.

If the Reset Orig Zero entry is selected, the display will ask **Erase?... ← FOR YES.** Press ← to use the factory set calibration. The Reset Orig Zero line of Figure 57 will disappear. It is

necessary to select Update and Quit to make the reset permanent.

8.6.3.2.3 Zero Cal(ibration)

Selecting Zero Cal will result in the display shown in Figure 58.

```
ZERØ CAL
The Sensor must
be fully purged
before setting
Zero. See Manual

To continue ...
Press any key
```

Figure 58: Zero Cal Warning Screen

Note: The zero baseline stabilization criteria is only verifying stability over a short time scale (1-5 minutes). The output on zero gas should be recorded (by manual or strip chart technique) and stability should be monitored over a much larger time scale (18 to 24 hours for 0-1000 ppm and lower range High Resolution Analyzers). Only when it is clear that the Oxygen reading has reached a constant minimum value should a zero calibration be attempted.

When any key is pressed, the display will show Figure 59 without the OFFSET line. This screen will be overwritten with a "WAIT..." message for about ten seconds and then the OFFSET: line will appear. Two beeps will sound when the "WAIT..." message clears. When the offset is stable, the instrument will sound two short beeps and display a "STABLE" message on the blank line below ZERO CAL. The user has the option to accept the new offset value by pressing the  key, or not accepting the new offset value by pressing the ESC key. With either choice, the display will return to the SENSOR ZERO Menu as seen in Figure 57.

```
ZERØ CAL

OFFSET: 23.4

When OFFSET is
stable press 

ESC to abort
```

Figure 59: Zero Cal Screen

Pressing the ESC key at any time aborts the process and returns the user to the SENSOR ZERO

menu.

If  is pressed before the “STABLE” message is displayed the screen will change as shown in Figure 60.

```
ZERO CAL
NOT STABLE YET!
 TO USE ANYWAY

When OFFSET is
stable press 

ESC to abort
```

Figure 60: Zero Cal Not Stable

To accept the unstable OFFSET value press . This is not recommended! The offset value at this point may not be satisfactorily close to the eventual zero baseline level because the zero baseline level is still equilibrating. To resume stabilization press ESC.

During Zero Cal the other messages that may appear below ZERO CAL are:

INVALID DATA - Indicates that the instrument's analog- to-digital converter is reading a value which is over or under its full scale range. Check sensor's electrical connections and the delivery of oxygen free sample gas (see PRESCALER HIGH below).

8.6.3.3 Test Output



The Test Output entry is used to calibrate the recorder. When the Test Output option is selected, the display will show Figure 61.

```
Press  to set
DAC to desired
%FS Level

Output: 0%

ESC to quit
```

Figure 61: Test Output Screen

Use the  key to set the desired output level in 10% percent steps of full scale from 0% to 100%. After setting the **% FS Level**, press . The analog output response should match the %FS Level value that was entered. For example, if 80% is entered for the %FS value on a 0-10

VDC recorder, the output will be 8.000 VDC. See the sticker inside the front door that indicates to what full-scale voltage the Analog Output has been configured.

8.6.3.4 Test Relays

The **Test Relays** selection in the Diagnostics Menu, Figure 56, is used to assure that the relay outputs are functioning. When the Test Relays option is selected, the display will show Figure 62.

```
RELAYS
* RELAY 1 (OFF)
  RELAY 2 (OFF)
  RELAY 3 (OFF)
  RELAY 4 (OFF)

ESC to Quit
```

Figure 62: Test Relay Screen

Select the relay to be tested, then press **←**. The relay will toggle between on and off each time **←** is pressed. An audible click will occur. The condition of the relays before the test will be restored when the test is concluded.

8.6.3.5 Memory Test

The Memory Test selection is used to test the internal memory of the Analyzer. When the Memory test option is selected from the Diagnostics Menu, Figure 56, the display will show Figure 63. Testing automatically begins.

```
MEMORY TEST
WAIT...
ROM: OK
IRAM: OK
XRAM: OK

Press any Key
```

Figure 63: Memory Test Screen

During the ROM test the program EPROM contents is used to calculate a checksum, which is compared to a checksum that was stored in the EPROM at the factory. Any changes in the program code can be detected. Next, the microprocessor internal memory (IRAM) is tested, followed by the system “external” random access memory (XRAM). As each portion of the memory is successfully tested an OK will appear at the end of the line. If any memory test fails,

repeat the test. If a failure is repeated contact the local Servomex Business Center.

8.6.3.6 Screen Test

When the screen test option is selected, the display will test each pixel. A series of horizontal lines will appear on the display, followed by a series of vertical lines. After the test has been completed, the display will return to the Diagnostics Menu, Figure 56. Pressing ESC will abort the screen test. If an error message appears, or a pixel is inactive, contact the local Servomex Business Center.

8.6.3.7 EXT Functions

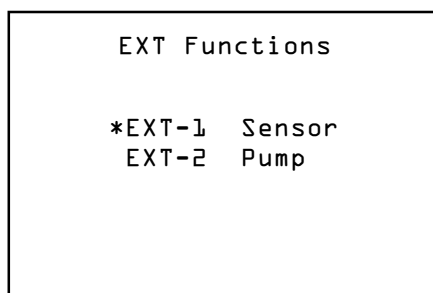

Figure 64: EXT Functions

The EXT Function screen indicates to the user which, if any, functions have been factory programmed for remote control through the J6 connector. Chosen at the time of order, the following analyzer functions can be remotely controlled: Sensor polarizing voltage or Pump on/off. See page 47 for additional information on wiring. NU will appear if no functions have been enabled. It is important to note that the front panel has no control of these functions while the analyzer is under remote control.

If the sensor polarization voltage has been turned off remotely, the display will indicate EXT SENSOR! at the bottom.

If the pump has been turned on remotely, the display will indicate EXT PUMP at the bottom.

9 Troubleshooting and Calibration

9.1 Return Material Authorization Number

If an analyzer has to be returned to the factory, the shipper will have to obtain a Return Material Authorization number from Servomex by calling the local Business Center. See the Shipping Section on page 103 for more details.

9.2 Maintenance

The analyzer maintenance recommendations made in this manual apply to all Analyzers being operated under Normal Operating Conditions and in clean gas applications.

A clean gas application is one in which certain process conditions are met. The sample background gas must contain less than 10% of the acid gas limits shown in Table 2 page 33, on a continuous basis. Solvents or other gases that are listed as “very soluble” to “infinitely soluble” in water must make up less than 0.1% of the background gas composition. Sample condensation must be avoided. For a hydrocarbon background gas, the sample must be kept at a temperature of at least 40°F over the sample dewpoint. A wet sample (high water dewpoint) must be kept at a temperature of at least 10° F over the dewpoint. The particulate density must be below the limit of 0.03 mg/L (weight of particulate matter / volume of sample at atmospheric pressure).

Some examples of clean gas applications include monitoring of high purity gas pipelines, compressed cylinder gases, cryogenic air separation plants, polyolefin feedstocks, glove boxes, and semiconductor process tools.

9.2.1 Calibration

All Servomex DF-310E Process Oxygen Analyzers are calibrated with NIST (National Institute For Standards And Technology) traceable certified gas standards at the factory prior to shipment. No initial calibration is required upon receipt from the factory.

For Analyzers used in clean gas applications (as described above) and operated under Normal Operating Conditions, Servomex recommends verifying the span calibration every 12 months of continuous use. This can be accomplished by using the Analyzer to read a gas sample with a known concentration, such as a certified cylinder gas mixture of O₂ in N₂ background, available from any specialty gas supplier. For process applications containing more significant quantities of acid gases or particulate, or where liquids may be encountered, contact Servomex for a recommendation on calibration verification for your specific case.

For Analyzers used in clean gas applications, and operated under *Normal Operating Conditions* there is no need for zero calibration checks in the field.

NOTE



If the analyzer is used in a portable mode, the optional isolation valves should be used during transport to preserve the stability of the zero calibration.

9.2.2 Storage Conditions

The Oxygen sensor was drained of electrolyte and thoroughly rinsed prior to shipment. Residual fluid will maintain in the electrode systems for several weeks during transportation and installation. If it is intended to store the system or delay installation and start-up for two months or more it is recommended that the sensor be filled to the bottom of the reservoir with Hummingbird *Replenishment Solution (RSA)*, which is provided as part of the *Start-up and Maintenance Kit*. Remember to securely replace the cap when done. For extended storage, six months or more, additional fluid should be added to allow for normal evaporation. At time of start-up it is recommended that any remaining *Replenishment Solution* be drained prior to addition of the fresh electrolyte. Be sure that the storage location temperature does not exceed 50° C (122° F). Storage in direct sunlight can cause temperatures to exceed the recommended limits even though ambient temperatures may be below the maximum temperature.

9.2.3 Sensor Maintenance

The analyzer does not require routine maintenance other than adding Replenishment Solution to the electrolyte. Exposure to dry gas for an extended time gradually extracts water from the sensor. The electrolyte needs to be refilled occasionally with Hummingbird Replenishment Solution for optimum performance and long term reliability.

CAUTION



If the electrolyte level is low, only Hummingbird Replenishment Solution should be added to the sensor for optimum performance and long term reliability. Be sure to cap the bottle immediately after use. In an emergency, distilled water can be used as an alternative, however this is not recommend over an extended period. **Do not add electrolyte solution to restore the electrolyte level.** Do not overfill.

The Sensor Assembly consists of two connected chambers. The operation of the sensor is satisfactory as long as the level of electrolyte is above the minimum indicator line and below the maximum line on the reservoir label.

One bottle of electrolyte, contains 100cc and the entire contents of the bottle should be added at the time of startup. This quantity is sufficient for satisfactory operation. It is not necessary to add additional electrolyte.

Typically, bone dry sample gas can extract approximately 5 to 10 cc of water per month. The electrolyte level should be checked every 1 to 2 months. If the liquid level is low, add Hummingbird Replenishment Solution to bring the electrolyte level between the minimum and maximum indicator lines on the reservoir label. Operation at elevated temperatures and/or with sample gases at very low dew points will increase the frequency of replenishing the electrolyte. The Oxygen Analyzer is equipped with an Electrolyte Condition alarm to indicate that the

electrolyte level is low. The operation of this alarm is described in the *Alarms* section.

9.2.4 Procedure for Adding Replenishment Solution to the Sensor

- 1) Open the front door.
- 2) Unscrew and remove the sensor cover. Remember, the electrolyte is caustic; be careful of drips of electrolyte from the cover.
- 3) Add Hummingbird Replenishment Solution to the electrolyte solution using the supplied squeeze bottle.
- 4) Fill to the max level indicator line on the reservoir label. Be careful not to spill solution on the electronics or on the outside of the sensor. **Do not overfill.**
- 5) Replace the cover securely and close the front door.

CAUTION



If the electrolyte level is low, only Hummingbird Replenishment Solution should be added to the sensor for optimum performance and long term reliability. Be sure to cap the bottle immediately after use. In an emergency, distilled water can be used as an alternative, however this is not recommend over an extended period. **Do not add electrolyte solution to restore the electrolyte level.** Do not overfill.

9.3 Replaceable Parts List

Included in the following list are all major parts that are field replaceable. This list is not intended as a recommendation of spare parts to be stored in case of failure.

When ordering replacement parts, be sure to include the analyzer serial and model numbers.

| | |
|--|------------------|
| Battery - NiMH | 210538 |
| Cable – Display to Main Board | 210381 |
| Cable – Sensor to Main Board | 210394 |
| Connector - (8 pin) | 210407 |
| Connector - (4 pin) | 210402 |
| Display assembly with PCB | 210527 |
| Hummingbird Brand Electrolyte Blue | ELECTROLYTE_BLUE |
| Feet - Rubber | 210411 |
| Filter Element - Coarse | 210412 |
| Filter Element - Fine | 210413 |
| Flow Meter (0-5 scfh) | 211282 |
| Flow Meter (0-2 scfh) | 210614 |
| Flow Meter w/Valve (0-5 scfh) | 210573 |
| Flow Meter w/Valve (0-2 scfh) | 210852 |
| Flow Switch (all except 25% analyzer) | 210517 |
| Flow Switch (25% analyzer only) | 210518 |
| Fuse 24 VDC Operation - 1A | 210425 |
| Fuse 100-240 VAC Operation - 2.5A | 210424 |
| Fuse – Battery Backup - 3.15A | 210430 |
| Handle Assembly | 210530 |
| Instruction Manual | 210450 |
| Orifice (0.010 inch) for 0-50ppm sensor | 210354 |
| PCB - CPU | 210470 |
| PCB – 24VDC Power Supply | 210491 |
| PCB – Battery Backup | 210469 |
| PCB – 4-20mA | 210466 |
| Power Cord | 210408 |
| Power Supply (100-240VAC) | 210500 |
| Pump - 12 VDC w/wo Battery Backup | 210502 |
| Hummingbird Brand Replenishment Solution – 100ml | 210515 |
| Hummingbird Brand Replenishment Solution – 0.5l | 210514 |
| Hummingbird Brand Replenishment Solution – 1.0l | 210513 |
| Hummingbird Brand Replenishment Solution – 2.0l | 210516 |
| Oxygen Sensor | Consult Servomex |
| Sensor Cap - Blue | 210397 |

Table 17: Replaceable Parts

9.4 Troubleshooting

The following *Troubleshooting Guide* helps the user resolve many of the common operational situations that occur with the analyzer. Investigate possible remedies in the listed order.

9.4.1 Sample System Leak Test (Low Flow Sensitivity)

By far the most common reason for high Oxygen readings is a leak in the sample delivery system. Leaks are divided into two types: real leaks and virtual leaks. A real leak is a lack of integrity in the sample delivery system. A virtual leak is caused by Oxygen that is trapped in the upstream plumbing and components, such as regulators and filters. This Oxygen is slowly being purged out of the system. Virtual leaks are most common in new installations.

Determining the nature of the leak is not a difficult task. It is important to be consistent in the approach and technique. The steps listed below will be helpful toward resolving any leak related problems.

1) Determine if the high reading is due to a leak or is a real indication of Oxygen level. This can be easily done by performing a "Flow Sensitivity Test". If the Analyzer is equipped with a pump, it is recommended that it not be used during the Flow Sensitivity Test. This test requires a positive pressure sample delivery system. If it is not possible to provide positive sample pressure to the Analyzer, skip to Step 2. Perform the Flow Sensitivity Test as follows:

a) Establish a flow rate that is within the normal operating tolerances of the Analyzer. Generally a flow rate between 0.5 LPM or 1.0 SCFH is ideal.

b) Give the Analyzer a couple of minutes to stabilize, and then carefully note the flow rate and the Oxygen level displayed.

c) Reduce the flow rate by 75%. In a system with good integrity, there should be little change in the front panel display. If a leak exists, however, the reading will rise noticeably. Allow it time to stabilize, and carefully note the flow rate and the Oxygen level displayed.

d) Re-establish a normal flow rate and allow the Analyzer to purge for ½ hour. Note again the flow rate and Oxygen level displayed.

e) Repeat step c. If the Oxygen level stabilizes at a level that is close to the prior value from step c, then the leak is real. If the reading shows a lower Oxygen level than the prior value from step c, the leak is probably a virtual leak and continued purging should rectify the problem.

2) Once it has been determined that there is a leak, the next logical step is to locate it. The easiest way to locate a leak is to close off the feed to the Analyzer from the sample delivery system, and to allow the system to pressurize. Apply Snoop® or another type of liquid leak detector to all of the fittings on the system. Any fitting that shows bubbles should be tightened or replaced.

3) If it is not practical to remove the Analyzer from the sample delivery system, leaks can be located by monitoring Analyzer output while applying Snoop® or another liquid leak detector to one fitting at a time. Snoop® will not show bubbles at the low pressure required for proper Analyzer operation. However, Snoop® will temporarily block any leak, at the fitting being checked, and the Analyzer output will drop. It is important to give sufficient time for the Analyzer to respond before going on to the next fitting. The more distance between the fitting and the Analyzer, the more time should be given for the Analyzer to respond.

9.4.2 Basic Troubleshooting

Solutions are listed in the order that they should be attempted.

| PROBLEMS | POSSIBLE SOLUTIONS |
|---|---------------------------|
| 1) Analyzer reads low | A B D E H I J Z |
| 2) Analyzer reads high | A B C D E I J Z |
| 3) Analyzer output is noisy | A E I Z |
| 4) Analyzer reads high with pump on | C Z |
| 5) Analyzer reads 0.00 at all times | Q D Z |
| 6) Slow speed of response | G C D E Z |
| 7) Electrolyte residue (white powdery build-up) visible on the sensor | Z |
| 8) Electrolyte Condition alarm “ON” | P D E Z |
| 9) Display is blank, or shows an unusual appearance | K O Z |
| 10) Display reads any of the following: | |
| - Over Range or TEMP OVER RANGE | L M N Z |
| - NOVRAM Failure | Z |
| - Uncalibrated | Z |
| 11) Span reading is unacceptably high (>50% high) | R C J Z |
| 12) Span reading is unacceptably low (>50% low) | R J E Z |

SOLUTIONS KEY

- A) Check instrument performance using a gas standard of known Oxygen content (Span).
- B) Check that the Analyzer zero setting matches the original factory setting. Consult the manual or the factory to verify these settings.
- C) Check the sample delivery system for leaks.
- D) Verify that the correct voltages are being supplied to the sensor. These voltages should be checked with the leads disconnected from the sensor. The voltages measured should be as follows:
- | | |
|-----------------------|---|
| Primary Electrodes: | wht/yel (-) to wht/blk/red (+) = 1.30 ± 0.065 VDC |
| Secondary Electrodes: | wht/blu (-) to wht/red (+) = 5.3 ± 0.5 VDC |
- Voltage levels between any other combination of wires should be less than 0.10 VDC. If there is any deviation from these values, contact the local Servomex Business Center
- E) Change the electrolyte. Use only electrolyte supplied by Servomex. Other types of electrolyte can damage the sensor and will void the warranty. Always rinse and drain the cell with distilled water at least three times before refilling the sensor with fresh electrolyte. Fill the sensor with exactly one full bottle of electrolyte (100 cc). For best results, the sensor should sit for 60 minutes before flowing gas through it. Then allow the Analyzer to operate for several hours on Nitrogen or other inert gas. A calibration check is recommended if performance was poor prior to the electrolyte change.
- G) Remove and check the filter element. Replace if needed.
- H) Check for contaminated plumbing. This is most easily done by examining the rotameter (if so equipped) or Tygon tubing downstream from the sensor for evidence of oil, powder, or other material that may have made its way from the process to the Analyzer.
- I) Remove any devices being driven by the Analyzer output, i.e., chart recorders, data acquisition systems, etc. Also, disconnect anything controlled by the Analyzer alarm relays. Attempt operation with these devices removed.
- J) Ensure that the background gas is compatible with the Analyzers' current calibration. Otherwise, select the appropriate GSF value (if equipped with the GSF option), or offset the display readings externally by the appropriate Background Gas Correction Factor amount. See page 79 for more information.
- K) Press the  key once. If the display remains unchanged, power the Analyzer down momentarily, and then power it back up.
- L) Ensure that the Analyzer has adequate sample flow.

M) Ensure that the sensor polarization voltage is turned on. See page 66.

N) Enter the Diagnostics menu and verify that the temperature is between 0° and 45°C. If temperature indicates erroneously high, check for good contact at the red and black wires on the sensor harness connector (for Analyzers having the sensor in the cabinet), or at all remote wiring connection point (starting at rear panel connector J11 pins 1 and 2) for remote sensors. Also, in remote sensor applications, verify that the temperature sensor wires are not reversed.

Note: The sensor temperature reading is only updated when entering the Diagnostics menu. After checking wiring connections leave the Diagnostics menu, wait one minute, and enter the menu again. The temperature value will be new, and should now be correct.

O) Confirm that the power supply is turned on, operating at the proper voltage and is connected properly to the analyzer.

P) Add Hummingbird Replenishment Solution if electrolyte level is near or below “MIN” mark.

Q) Check the sensor wiring. Make sure the nuts holding the wires to the sensor have not come loose. Trace the wires from the sensor back to the sensor connector. Make sure that the terminal pins are seated correctly in the connector plugs and are making good contact through the connector. Trace the wires further back to the main PCB connector. Make sure the wires are crimped correctly and none have broken loose.

R) Check the accuracy and age of the calibration reference cylinder. Trace O₂ standards in steel cylinders decay over time due to oxidation of the cylinder walls. Standards below 100 ppm, in steel cylinders, should be re-analyzed or calibrated every three months. Ideally, standards below 100 ppm, and certainly standards below 10 ppm, should be prepared in aluminum cylinders.

Z) Contact the local Servomex Business Center For faster service, have the instrument serial number and model number in hand before calling. Always be certain to drain the sensor of electrolyte before returning it to the factory for repair.

9.4.3 Fuse Replacement

DANGER



*The instrument power must be shut off before removing the fuse.
Failure to do so may expose the operator to hazardous voltages.*

The operating voltage of the analyzer is marked on a label located on the rear of the cabinet. Always use the proper fuse for the operating voltage of the analyzer.

9.4.3.1 AC Power Fuse

If configured with an integral 100-240 VAC power supply, the 5X20 mm, 250 VAC, IEC Sheet III, Type T fuse is rated at 2.5A. There are two fuses that are located in the AC input connector located behind the cover on the rear of the cabinet.

Refer to the spare parts list on page 96 for Servomex replacement part numbers.

9.4.3.2 DC Power Fuse

If configured for 24 VDC operation, the 1.0A type TE-5 fuse is located on the under side of the 24VDC power PCB (#10334850). See Figure 65. To access this board, the entire board set must be removed from the cabinet after disconnecting the sensor cable, the rear connectors and removing the two mounting screws on the rear of the cabinet. Remove the metal cover plate and the power supply board can then be gently separated from the main CPU to access the fuse.

Refer to the spare parts list on page 96 for Servomex replacement part numbers.

9.4.3.3 Battery Backup Fuse

If configured with the Battery Backup option, the 3.5A type TE-5 fuse is located on the under side of the battery charge PCB (#10334870). See Figure 65. To access this board, the entire board set must be removed from the cabinet after disconnecting the sensor cable, the rear connectors and removing the two mounting screws on the rear of the cabinet. Remove the metal cover plate and the power supply board can then be gently separated from the main CPU to access the fuse.

9.4.3.4 4-20mA Output Fuse

The 4-20mA analog output is fused by a fast acting, automatically resetting, 100mA circuit breaker.

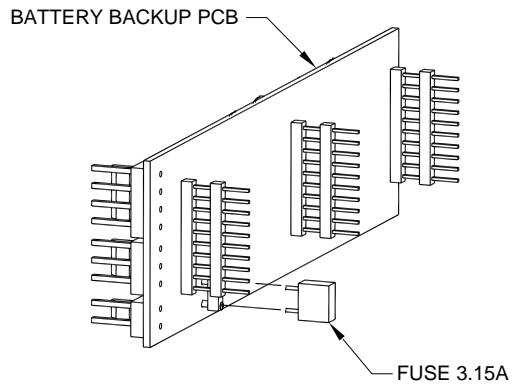
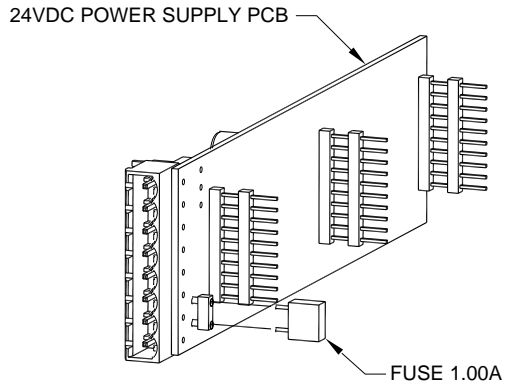

Figure 65: Fuse Locations for DC Power Supply and Battery Backup

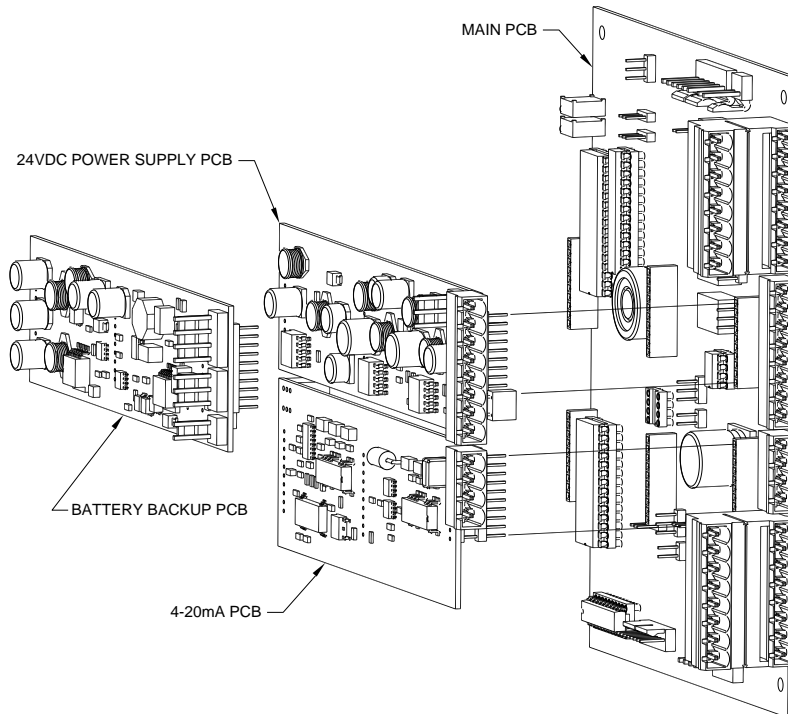

Figure 66: Printed Circuit Board Assembly

9.5 Shipping

If it comes necessary to return the analyzer to the factory or ship it to another location, please follow the packaging and shipping procedure below in order to prevent damage to the analyzer during shipment.

CAUTION



Do not ship the analyzer with electrolyte - thoroughly drain and rinse sensor before shipping

Note: If you are returning the analyzer to the factory, first call Servomex to obtain a **Return Material Authorization number** (see complete details below), then proceed as follows:

1. Turn off and disconnect the power source from the analyzer.
2. Disconnect all external electrical connections (alarms, data output, etc.). Mark each for re-attachment later.
3. Remove the sensor as described on page 14.
 - a. Drain the electrolyte into a receptacle suitable for proper disposal.
 - b. Rinse the sensor with distilled water at least three times. Drain the water into the receptacle.
 - c. Securely hand tighten the cover.
4. Reinstall the sensor using the two sensor mounting screws.
5. Install the bulkhead lock nut. Cap the inlet fitting to prevent debris from entering.
6. Put the analyzer in its original container. Ensure that all internal components are adequately secured. It is recommended that bubble packing or similar protective material be added inside the container for added protection.

If you are returning the analyzer to the factory, contact the local Servomex Business Center to obtain a **Return Material Authorization number**. Clearly mark the Return Material Authorization number on the outside of the shipping container and on the packing list. The analyzer must be returned freight prepaid.

10 Theory of Operation

10.1 The Oxygen Sensor

The Servomex Coulometric Sensor uses an ambient temperature oxygen reaction that is non-depleting. The cell produces a current flow that is determined by the number of oxygen molecules that are reduced at the cathode. The sensor reaction is driven by 1.3 Volts applied across the electrodes. The resulting electron flow is measured as a current that is precisely proportional to the oxygen concentration in the sample gas.

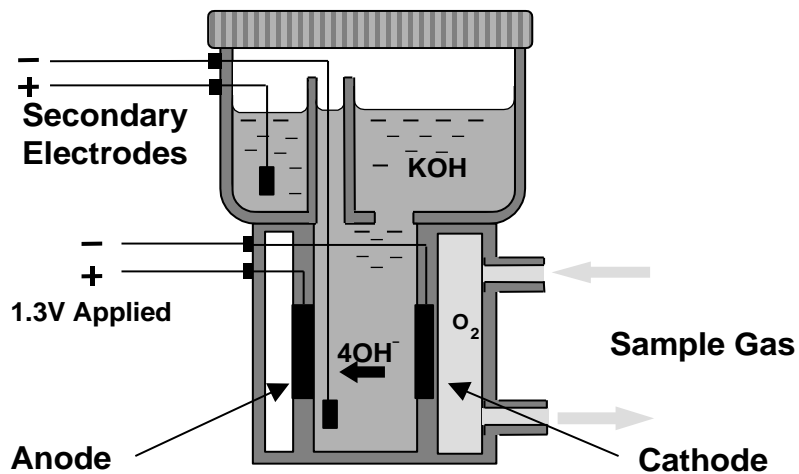
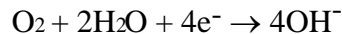
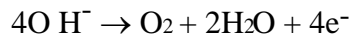

Figure 67: Schematic of Servomex Oxygen Sensor

The cathode reaction uses 4 electrons from the 1.3 volt circuit, 2 water molecules from the electrolyte, and 1 oxygen molecule from the sample gas to generate 4 hydroxyl ions which migrate across the reaction chamber to the anode:



The anode reaction consumes the 4 hydroxyl ions and delivers 4 electrons to the circuit, 2 water molecules back to the electrolyte, and vents one oxygen molecule.



There is no net change to the electrolyte and no depletion of the sensor or electrodes.

10.2 The Electrolyte Conditioning System

The Process Oxygen Analyzer is equipped with Servomex's patented electrolyte conditioning system and is composed of two specialized electrode pairs.

The patented secondary electrode pair protects the sensing electrodes from the deleterious effects of trace impurities inevitably found in the electrolyte. The secondary electrodes attract and trap trace ionic impurities present in the electrolyte, providing a scavenging function that results in long-term zero and span stability.

11 Safety

CAUTION



Do not setup or operate the Oxygen Analyzer without a complete understanding of the instructions in this manual. Do not connect this Analyzer to a power source until all signal and plumbing connections are made.

CAUTION



This analyzer must be operated in a manner consistent with its intended use and as specified in this manual.

DANGER



Potentially hazardous AC voltages are present within this instrument. Leave all servicing to qualified personnel. Disconnect the AC power source when installing or removing: external connections, the sensor, the electronics, or when charging or draining electrolyte.

DANGER



The electrolyte is a caustic solution. Review the Material Safety Data Sheet (MSDS) before handling the electrolyte solution.

The sensor is shipped dry and must be charged with electrolyte before it is operated.

CAUTION



Over-pressurizing the sensor can result in permanent damage to the sensor. Limit the backpressure to the analyzer to ± 1 psig. Be sure the downstream isolation valve (if so equipped) is toggled open **before** gas flow is started.

CAUTION



DO NOT SHIP THE ANALYZER WITH ELECTROLYTE – THOROUGHLY DRAIN AND RINSE SENSOR BEFORE SHIPPING

EMI DISCLAIMER



This Analyzer generates and uses small amounts of radio frequency energy. There is no guarantee that interference to radio or television signals will not occur in a particular installation. If interference is experienced, turn-off the analyzer. If the interference disappears, try one or more of the following methods to correct the problem:

Reorient the receiving antenna.

Move the instrument with respect to the receiver.

Place the analyzer and receiver on different AC circuits.

11.1 Electrolyte Solution MSDS

1. IDENTIFICATION OF THE SUBSTANCE

Trade Name Electrolyte Solution, *E*-lectrolyte Gold, *E*-lectrolyte Blue, *E*-lectrolyte Black, DF-E05, DF-E06, DF-E07, DF-E09

Manufacturer Servomex Corp., 4 Constitution Way, Woburn, MA 01801-1087, USA, Tel + 1-781-935-4600

Emergency Contact USA: 1-800-424-9300
International: 1-813-979-0626 (collect)

| | |
|---|--|
| Supplier and contact in UK (for use in the UK only) | |
|---|--|

2. COMPOSITION

| CAS # | Component | EC Code/class | Concentration | Risk Phrase | Risk Description |
|-----------|---|----------------|--------------------|-------------|---------------------|
| 7732-18-5 | Water | 231-791-2 | | | |
| 1310-58-3 | Potassium Hydroxide in aqueous solution | 215-181-3 C | 0.77N: 4.3% w/w | R35 | Causes severe burns |

3. HAZARDS IDENTIFICATION

Main Hazard Corrosive. Causes severe burns on contact with skin, eyes and mucous membrane

CERCLA Ratings (scale 0-3) Health = 3 Fire = 0 Reactivity = 1 Persistence = 0

NFPA Ratings (scale 0-4) Health = 3 Fire = 0 Reactivity = 1

Potential Health Effects:

Eye Contact Causes severe eye burns. May cause irreversible eye injury. Contact may cause ulceration of the conjunctiva and cornea. Eye damage may be delayed.

Skin Contact Causes skin burns. May cause deep, penetrating ulcers of the skin.

Ingestion May cause circulatory system failure. May cause perforation of the digestive tract. Causes severe digestive tract burns with abdominal pain, vomiting, and possible death.

Inhalation Inhalation under normal use would not be expected as this product is supplied as an aqueous solution and no hazardous vapors are emitted. Effects of inhalation are irritation that may lead to chemical pneumonitis and pulmonary edema. Causes severe irritation of upper respiratory tract with coughing, burns, breathing difficulty, and possible coma.

Chronic Prolonged or repeated skin contact may cause dermatitis. Prolonged or repeated eye contact may cause conjunctivitis.

4. FIRST-AID MEASURES

Skin Contact In case of skin contact, remove contaminated clothing and shoes immediately. Wash affected area with soap or mild detergent and large amounts of water for at least 15 minutes. Obtain medical attention immediately.

| | |
|--------------------|--|
| Eye Contact | If the substance has entered the eyes, wash out with plenty of water for at least 15 - 20 minutes, occasionally lifting the upper and lower lids. Obtain medical attention immediately. |
| Ingestion | If the chemical has been confined to the mouth, give large quantities of water as a mouthwash. Ensure the mouthwash has not been swallowed. If the chemical has been swallowed, do NOT induce vomiting. Give 470 - 950ml (2 - 4 cups) of water or milk. Never give anything by mouth to an unconscious person. Obtain medical attention immediately. |
| Inhalation | Inhalation under normal use would not be expected as this product is supplied as an aqueous solution and no hazardous vapors are emitted; however, if inhalation should somehow occur, remove from exposure to fresh air immediately. If not breathing, give artificial respiration. If breathing is difficult, give oxygen. Seek medical aid immediately. |

5. FIRE FIGHTING MEASURES

| | |
|--------------------------------|--|
| Special Exposure Hazard | Not applicable |
| Extinguishing Media | Not Combustible. Select extinguishing media appropriate to the surrounding fire conditions. |
| Protective Equipment | Wear appropriate protective clothing to prevent contact with skin and eyes. Wear a self-contained breathing apparatus (SCBA) to prevent contact with thermal decomposition products. |

6. ACCIDENTAL RELEASE MEASURES

| | |
|----------------------------|---|
| Personal Protection | Use proper personal protective equipment as indicated in Section 8. |
| Leaks and Spills | Absorb spill with inert material (e.g., dry sand or earth), then place into a chemical waste container. Neutralize spill with a weak acid such as vinegar or acetic acid. |
| Clean-up Procedures | Wash the spillage site with large amounts of water. |

7. HANDLING AND STORAGE

| | |
|-----------------------------|---|
| Handling Precautions | Complete eye and face protection, protective clothing, and appropriate gloves must be used. Do not get in eyes, on skin, or on clothing. Wash thoroughly after handling. Remove contaminated clothing and wash before reuse. Do not ingest or inhale. |
| Storage Precautions | Store in a tightly closed container. Store in a cool, dry, well-ventilated area away from incompatible substances. Keep away from strong acids. |

8. EXPOSURE CONTROLS / PERSONAL PROTECTION

| | |
|----------------------------|---|
| Personal Protection | |
| Eyes | Wear appropriate protective chemical safety goggles and face shield as described by OSHA's eye and face protection regulations in 29 CFR 1910.133 or European Standard EN166. |
| Skin | Wear appropriate gloves to prevent skin exposure. |
| Clothing | Wear appropriate protective clothing to prevent skin exposure. |
| Respirators | Not Applicable. Inhalation under normal use would not be expected as this product is supplied as an aqueous solution and no hazardous vapors are emitted. |
| Airborne Exposure | This material is supplied as an aqueous solution and will not be present in the atmosphere in normal use. |
| Exposure Limits | Potassium Hydroxide |

UK EH40, OEL (8hr TWA) 2mg/m³
NIOSH, (8hr TWA) 2mg/m³
ACGIH, Ceiling 2mg/m³
OSHA, not listed

9. Physical & Chemical Properties

| | |
|--------------------------|--|
| Molecular Formula | KOH Mixture |
| Physical State | .77N aqueous solution. Colorless, odorless |
| pH | Alkaline |
| Solubility | Completely soluble in water |
| Boiling Point | 104.5°C |
| Melting Point | -3.5°C |
| Flash Point | Not applicable |
| Flammability | Not flammable |
| Explosion Limits | Not applicable |
| Specific Gravity | 1.15 |
| Vapor Pressure | 16.1 mm Hg @ 20°C |

10. Stability & Reactivity

| | |
|---|---|
| Chemical Stability | Stable |
| Conditions/Materials to Avoid | Incompatible materials, acids and metals |
| Incompatibilities with other Materials | Reacts with chlorine dioxide, nitrobenzene, nitromethane, nitrogen trichloride, peroxidized tetrahydrofuran, 2,4,6-trinitrotoluene, bromoform+ crown ethers, acids alcohols, sugars, germanium cyclopentadiene, maleic dicarbide. Corrosive to metals such as aluminum, tin, and zinc to cause formation of flammable hydrogen gas. |
| Hazardous Decomposition Products | Oxides of potassium |
| Hazardous Polymerization | Has not been reported |

11. Toxicological Information

| | | |
|--------------------------|----------------|--|
| RTECS# | CAS# 7732-18-5 | ZC0110000 |
| | CAS# 1310-58-3 | TT2100000 |
| LD50/ LC50 | CAS# 7732-18-5 | Oral, rat: LD50 = >90 ml/kg |
| | CAS# 1310-58-3 | Draize test, rabbit, skin: 50 mg/24H Severe Oral, rat: LD50 = 273 mg/kg |
| Carcinogen Status | CAS# 7732-18-5 | Not listed by ACGIH, IARC, NIOSH, NTP, or OSHA |
| | CAS# 1310-58-3 | Not listed by ACGIH, IARC, NIOSH, NTP, or OSHA |

Potassium Hydroxide Solution is a severe eye, mucus membrane, and skin irritant.

12. Ecological Information

| | |
|----------------------|---|
| Mobility | Completely soluble in water |
| Degradability | Will degrade by reaction with carbon dioxide from the atmosphere to produce a non-hazardous product. |
| Accumulation | No |
| Ecotoxicity | Information not available. No long-term effects expected due to degradation. The preparation is already in dilute solution and adverse aquatic effects are not expected |

due to further dilution. The preparation is corrosive, and direct contact with fauna will cause burns.

13. Disposal Considerations

Waste Disposal Dispose of in a manner consistent with federal, state, and local regulations.

14. Transportation Information

| | Shipping Name | Hazard Class | UN Number | Packaging Group |
|---------------------|------------------------------|---------------------|------------------|------------------------|
| US DOT | Potassium Hydroxide Solution | 8 | UN1814 | II |
| IATA | Potassium Hydroxide Solution | 8 | UN1814 | II |
| ADR/RID | Potassium Hydroxide Solution | 8 | UN1814 | II |
| IMDG Code | Potassium Hydroxide Solution | 8 | UN1814 | II |
| Canadian TDG | Potassium Hydroxide Solution | 8(9.2) | UN1814 | Not Available |

15. Regulatory Information

US FEDERAL

| | | |
|---|----------------|---|
| TSCA | CAS# 7732-18-5 | Listed on TSCA Inventory |
| | CAS# 1310-58-3 | Listed on TSCA Inventory |
| Health & Safety Reporting List | | None of the chemicals on Health & Safety Reporting List |
| Chemical Test Rules | | None of the chemicals are under Chemical Test Rule |
| Section 12b | | None of the chemicals are listed under TSCA Section 12b. |
| TSCA Significant New Use Rule | | None of the chemicals have a SNUR under TSCA |
| CERCLA Hazardous Substances and corresponding RQ's | CAS# 1310-58-3 | 1000 lb final RQ; 454kg final RQ |
| SARA Section 302 Extremely Hazardous Substances | | None of the chemicals have a TQP |
| SARA Codes | CAS# 1310-58-3 | Immediate, Reactive |
| Section 313 | | No chemicals are reportable under Section 313 |
| Clean Air Act | | Does not contain any hazardous air pollutants Does not contain any Class 1 Ozone depletors Does not contain any Class 2 Ozone depletors |
| Clean Water Act | CAS# 1310-58-3 | Listed as a Hazardous Substance under the CWA None of the chemicals are listed as Priority Pollutants under the CWA |

None of the chemicals are listed as Toxic Pollutants under the CWA

OSHA

None of the chemicals are considered highly hazardous by OSHA

STATE

CAS# 7732-18-5

Not present on state lists from CA, PA, MN, MA, or NJ.

CAS# 1310-58-3

Can be found on the following state right to know lists; CA, NJ, PA, MN, MA.

California Prop 65

California No Significant Risk Level: None of the chemicals are listed.

European/International Regulations

European Labeling in Accordance with EC Directives

| | | |
|--|-----------------------|--|
| Classification | Corrosive | |
| Hazard Symbol | C | |
| EC Number | 215-181-3 | |
| Risk Phrases | R35 | Causes severe burns. |
| | R22 | Harmful if swallowed |
| Safety Phrases | S1/2 | Keep locked up and out of reach of children. |
| | S26 | In case of contact with the eyes, rinse immediately with plenty of water and seek medical advice. |
| | S36 | Wear suitable protective clothing. |
| | S37/39 | Wear suitable gloves and eye/face protection. |
| | S45 | In case of accident or if you feel unwell, seek medical advice immediately (show label where possible). |
| WGK (Water Danger/Protection) | CAS# 7732-18-5 | No information available |
| | CAS# 1310-58-3 | 1 |
| Canada – DSL/ NDSL | CAS# 7732-18-5 | Listed on Canada’s DSL List |
| | CAS# 1310-58-3 | Listed on Canada’s DSL List |
| Canada - WHMIS | Classification E, D1B | Classified in accordance with the hazard criteria of the Controlled Products Regulations and the MSDS contains all of the information required by those regulations. |
| Canadian Ingredient Disclosure List | CAS# 1310-58-3 | Listed on the Canadian Ingredient Disclosure List |

16. Other Information

MSDS Creation Date: 09/30/94

MSDS Revised: May 1, 2007

The information above is believed to be accurate and represents the best information currently available to us. However, we make no warranty of merchantability or any other warranty, express or implied, with respect to such information. Liability is expressly disclaimed for loss or injury arising out of use of this information or the use of any materials designated. Users should make their own investigation to determine the suitability of the information for their particular purpose.

11.2 Replenishment Solution MSDS

MATERIAL SAFETY DATA SHEET

1. IDENTIFICATION OF THE SUBSTANCE

Trade Name Replenishment Solution, RS-A

Manufacturer Servomex Corp., 4 Constitution Way, Woburn, MA
01801-1087, USA, Tel + 1-781-935-4600

Emergency Contact USA: 1-800-424-9300
International: 1-813-979-0626 (collect)

Supplier and contact in UK
(for use in the UK only)

2. COMPOSITION

| CAS # | Component | EC Code/class | Concentration | Risk Phrase | Risk Description |
|-----------|---------------------------------|----------------|---------------|-------------|------------------|
| 7732-18-5 | Water (contains trace salts) | 215-181-3 C | 100% | | |

3. HAZARDS IDENTIFICATION

Main Hazard None

CERCLA Ratings (scale 0-3) Health = 0 Fire = 0 Reactivity = 1 Persistence = 0

NFPA Ratings (scale 0-4) Health = 0 Fire = 0 Reactivity = 1

Potential Health Effects:

Eye Contact Not applicable.
Skin Contact Not applicable.
Ingestion Not applicable.
Inhalation Not applicable.
Chronic Not applicable.

4. FIRST-AID MEASURES

Skin Contact Not applicable.
Eye Contact Not applicable.

Ingestion Not applicable.
Inhalation Not applicable.

5. FIRE FIGHTING MEASURES

Special Exposure Hazard Not applicable

Extinguishing Media Not combustible. Select extinguishing media appropriate to the surrounding fire conditions.

Protective Equipment

In the event of a fire, wear full protective clothing and NIOSH-approved self-contained breathing apparatus with full facepiece operated in the pressure demand or other positive pressure mode.

6. ACCIDENTAL RELEASE MEASURES

Non-hazardous material. Clean up of spills requires no special equipment or procedures.

7. HANDLING AND STORAGE

Keep container tightly closed. Suitable for any general chemical storage area. Protect from freezing. May react vigorously with some specific materials. Avoid contact with all materials until investigation shows substance is compatible.

8. EXPOSURE CONTROLS / PERSONAL PROTECTION

Personal Protection

| | |
|--------------------|-----------------|
| Eyes | None required. |
| Skin | None required. |
| Clothing | Not applicable. |
| Respirators | Not Applicable. |

| | |
|--------------------------|-----------------|
| Airborne Exposure | Not applicable. |
|--------------------------|-----------------|

| | |
|------------------------|-----------------|
| Exposure Limits | Not applicable. |
|------------------------|-----------------|

9. Physical & Chemical Properties

| | |
|--------------------------|---|
| Molecular Formula | H ₂ O containing trace salts |
| Physical State | Colorless, odorless liquid |
| pH | 6.0-8.0 |
| Solubility | Complete (100%) |
| Boiling Point | 100°C |
| Melting Point | 0°C |
| Flash Point | Not applicable |
| Flammability | Not flammable |
| Explosion Limits | Not applicable |
| Specific Gravity | 1.00 |
| Vapor Pressure | 17.5 mm Hg @ 20°C |

10. Stability & Reactivity

| | |
|---|---|
| Chemical Stability | Stable |
| Conditions/Materials to Avoid | Strong reducing agents, acid chlorides, phosphorus trichloride, phosphorus pentachloride, phosphorus oxychloride. |
| Hazardous Decomposition Products | Not applicable. |
| Hazardous Polymerization | Has not been reported |

11. Toxicological Information

Toxicity (water) CAS# 7732-18-5: Oral, rat: LD50 >90 mL/kg
Carcinogen Status Not listed by ACGIH, IARC, NIOSH, NTP, or OSHA

12. Ecological Information

Mobility Completely soluble in water
Degradability Not applicable.
Accumulation Not applicable.
Ecotoxicity Applicable.

13. Disposal Considerations

Waste Disposal Whatever cannot be saved can be flushed to sewer. If material becomes contaminated during use, dispose of accordingly. Dispose of container and unused contents in accordance with federal, state, and local requirements.

14. Transportation Information

Not regulated.

15. Regulatory Information

16. Other Information

NFPA Ratings: Health: 0 Flammability: 0 Reactivity: 0

MSDS Creation Date: 09/30/94

MSDS Revised: December 7, 2006

The information above is believed to be accurate and represents the best information currently available to us. However, we make no warranty of merchantability or any other warranty, express or implied, with respect to such information. Liability is expressly disclaimed for loss or injury arising out of use of this information or the use of any materials designated. Users should make their own investigation to determine the suitability of the information for their particular purpose.

12 Warranty

Servomex Corporation warrants each instrument manufactured by them to be free from defects in material and workmanship at the F.O.B. point specified in the order, its liability under this warranty being limited to repairing or replacing, at the Seller's option, items which are returned to it prepaid within one year from delivery to the carrier and found, to the Seller's satisfaction, to have been so defective.

In addition, if the oxygen sensor in this analyzer fails under normal use within five years from the date of purchase, such sensor may be returned to the Seller and, if such sensor is determined by the Seller to be defective, the Seller shall provide the Buyer a repaired or replacement sensor at no additional cost. The original warranty expiration date is not extended by this action.

In no event shall the Seller be liable for consequential damages. **NO PRODUCT IS WARRANTED AS BEING FIT FOR A PARTICULAR PURPOSE AND THERE IS NO WARRANTY OF MERCHANTABILITY.**

Additionally, this warranty applies only if: (i) the items are used solely under the operating conditions and in the manner recommended in the Seller's instruction manual, specifications, or other literature; (ii) the items have not been misused or abused in any manner or repairs attempted thereon; (iii) written notice of the failure within the warranty period is forwarded to the Seller and the directions received for properly identifying items returned under warranty are followed; and (iv) with return, notice authorizes the Seller to examine and disassemble returned products to the extent the Seller deems necessary to ascertain the cause of failure. The warranties stated herein are exclusive. **THERE ARE NO OTHER WARRANTIES, EITHER EXPRESSED OR IMPLIED, BEYOND THOSE SET FORTH HEREIN,** and the Seller does not assume any other obligation or liability in connection with the sale or use of said products.

13 Index



▲, 59



▼, 59

2

2-20mA Analog Output, 25

4

4-20mA Analog Output, 25

4-20mA Output, 46

4-20mA Output Fuse, 101

A

AC Power Fuse, 101

Accuracy, 9

Acknowledged Alarm, 61

Alarms, 60, 68, 69, 70

Electrolyte Condition Alarm, 70

Low Flow Alarm, 20, 69

Oxygen Alarms, 68

Temperature Alarm, 69

Analog Output, 70, 89

Menu Settings, 70

Analog Output Range, 60

Analog Voltage Output, 45

Analyzer

Process Upsets, Protection from, 40

Specifications, 9

Unpacking, 4

Warranty, 119

Analyzer Trouble, 66

Annunciator Line, 59, 63, 89

Audible, 10, 69

B

Background Gas, 79

Correction Factors, 79

Backlight (BL), 75

Backplane, 100

Battery Backup Fuse, 101

Battery Power, 19

Battery Power, NiMH, 19

Baud, 74

Bits, 73

C

CAL FREEZE, 73

Calibrating, 82, 83, 84, 87, 93

Calibration, 79, 93

Case Purge, 30

Cautions, 7

Important Warnings, 7

Symbols and Explanations, 7

Check Fluid, 78

CHECK FLUID, 61

Check/Adj Cal, 79, 82

Clean Gas Applications, 93

Clock, 75

Comm Port, 73

Baud, 74

Device ID, 74

Communication Port – RS232/485

Port, 74

Condensation, 11

Contrast, 75

Controls, 63

Controls Menu, 65

Convergence, 85

coulometric, 105

D

Data Line, 59

DC Power Fuse, 101

Deadband, 69

Device ID, 74

Diagnostics, 76, 86

EXT Functions, 91

Memory Test, 90

Screen Test, 91

Sensor Temperature, 86

Sensor Zero, 86

Test Output, 89

Test Relays, 90

Dimensions, 11

DISABLING ALARMS, 67, 76, 77, 86

Display Setup, 74

E

Electrical Connections, 89

Electrolyte, 98, 99

- chemical reaction, 105
- Electrolyte Condition Alarm, 70
- EMI Sensitivity, 10
- Error, 82, 87
- ESC, 59, 64, 67
- Expand FS, 72
- Expanded Range Scale, 26
- Expanded Range Scale Output, 26, 72
- ExpRng Relay, 73
- EXT Functions, 91
- External Devices
 - Comm Port, 43
 - Option Ports
 - Changing Analog Output Voltage, 45
 - Relay Ports, 44
 - Remote Controls, 47
- External Devices, Connecting to, 43

F

- fault condition, 66
- Filter, 21
 - Oil/Solvent Mist, 11
 - Solid Particles, 11
- Filter Elements, 21
- Flow, 61, 69, 73, 84
- flow control, 19, 48
- Flow Control Valve, 21
- Fuse Replacement, 100
- Fuse, AC Power, 101
- Fuse, Battery Backup, 101
- Fuse, DC, 101

G

- Gas Compatibility, 11
- Gas Sample
 - Clean Gas Application, 93
- Gas Scale Factor, 79

H

- Handshaking (Serial Port), 73
- Hi Stpt**, 69
- High-Resolution Analyzers, 72

I

- IN-CAL Relay, 73
- INLET PRESSURE, 11
- Installation and Setup, 13
 - Adding Electrolyte, 14
 - Electrical Connections, 16
 - Low Flow Alarm, 20
 - Powering Up, 16
 - Pressure Regulator Installation, 21
 - Pressure Regulator Purge, 37
 - Sample Gas Connections, 15

- Standard Outputs, 17
- INVALID DATA**, 60, 89, 98
- IRAM, 90

K

- Key Lock, 24
- Keypad Operation, 64

L

- Leak (Plumbing), 99
- Level, 75
- Lo Stpt**, 69
- Loop Resistance (4-20 mA), 10
- Low Flow Alarm, 20, 69
- Low Flow Switch, 69

M

- Maintenance**, 63
 - Fuse Replacement, 100
- Maintenance Menu, 77
 - Reset the, 78
 - Set the, 78
- Maintenance, Analyzer, 93
- Master Password, 76
- Memory Error!, 61
- Memory Test, 90
- Menu**, 60

N

- NEMA 4 Enclosure, 51
- NEMA 7 Enclosure, 52
- New Sensor, 85
- NiMH Battery Power, 19
- Not Available, 68

O

- Operator Password, 76
- Options
 - 4-20mA Analog Output, 25
 - Battery Power, 19
 - Case Purge, 30
 - Communication Port – RS-232/485, 26
 - Dual Rack Mount, 28
 - Expanded Range Scale, 26
 - Filter, 21
 - Flow Control Valve, 21
 - Form C Relays, 25
 - Key Lock, 24
 - Low Flow Alarm, 20
 - Panel/Rack Mount, 26
 - Pressure Regulator, 21
 - Pump, 19
 - Rack Mount, 28

- Remote Display, 28
- Remote Sensor
 - Temperature Control, 53
- Stainless Steel Outlet Tubing, 24
- Outputs, Analog, 70
- OVER RANGE, 61
- Oxygen Alarms, 68

P

- Panel Mount, 26
- Password**, 63
 - Misplaced, 77
- Password Menu, 76
- Port (Communication), 74
- Power Requirements, 10
- PRESSURE, 11
- Pressure Regulator, 21
- Procedure
 - Adding Replenish Solution to the Sensor, 95
 - Changing the Analog Output, 47
 - Purging Ambient Air from Regulator, 37, 41
- Pump, 19, 65
- Purging, 97

R

- Rack Mount, 28
- Recalibration, 87
- Relay**, 69, 90
- Relay Contact Closures, 10
- Remote Controls, 47
- Remote Display, 28
- Remote Pump Control, 48
- Remote Sensor
 - Temperature Control, 53
- Remote Sensor Connections, 54
- Remote Sensor Control, 47
- Remote Sensor Installations, 49
- Replenishment Sol'n Reminder, 78
- Reset Orig Span**, 79, 85
- Reset Orig Zero, 87
- Resolution, 9
- ROM, 90
- Rotameter, 65, 84

S

- Safety, 107
- Sample Gas, 79
- Sample Gas Preparation and Delivery, 33
 - Background Gas Effects, 36
 - Backpressure Effects, 38
 - Flow Rate Effects
 - Leakage Checks, 36
 - Sensor Performance, 36

- Pressure Effects
 - Sensor Performance, 37
- Regulator Requirements, 36
- Sample Flow Rate and Pressure, 35
- Sample Gas
 - Compatibility, 38
 - Reactivity with KOH Electrolyte, 39
 - Solubility in Aqueous KOH Solution, 39
 - Trace Acids, 39
- Sample Gas Calibration
 - Background Gas Effects, 42
 - Delivery and Vent Pressure, 41
 - Regulators, 41
 - Standards, 40
- Sample Gas Calibrations, 40
- Sample Gas Condensation, 38
- Sample Gas Flammability, 39
- Sample Gas Temperature, 40
- Sample GSF, 34
- STAB-EL Acid Gas System, 33
- Sample System Leak Test, 97
- Sampling Considerations
 - Clean Gas Application, 93
- Screen Test, 91
- Sensitivity, 9
- SensOFF Relay, 66, 67
- Sensor
 - anode, 105
 - cathode, 105
 - non-depleting, 105
 - operation, 105
- SENSOR OFF**, 60
- Sensor Off 4-20mA Signal, 67
- Sensor Polarization, 66
- Sensor Temperature, 86
- Sensor Zero, 86
- Service
 - Maintenance
 - Calibration, 93
 - Sensor, 94
 - Storage Conditions, 94
 - Return Material Authorization number, 93
 - Shipping, 103
 - Return Material Authorization number, 103
 - Troubleshooting, 97
 - Troubleshooting Guide, 97
- Set-Up Menu**, 63, 67
- SPAN REF**, 83
- Spare Parts List, 96
- Stainless Steel Outlet, 24
- Storage Temperature, 10

T

- TEMP OVER RANGE**, 61, 82
- Temperature, 10, 69, 100
- Temperature Alarm, 69

Test Output, 89
Test Relays, 90
Theory of Operation
 Electrolyte Conditioning System, 106
 Sensor, 105
TO, 61
Troubleshooting, 93, 98

U

UNCALIBRATED, 61, 98
UNDER RANGE, 61
Update And Quit, 74
Upstream Valve, 65
UR, 61
User Interface, 59
 Data Display Screen, 59

Main Menu, 63

W

Wait!, 61
Warranty, 119
Weight, 11

Z

ZERO CAL, 88
Zero Calibration Frequency
 Clean Gas Applications, 93
ZERO REF, 87
Z-Purge, 56

BUSINESS CENTERS

EUROPE (Europe and Africa)
Tel: +31 (0)79 330 1580
Fax: +31 (0)79 342 0819
Toll Free : 00800 7378 6639

USA & CANADA
Tel: +1 281 295 5800
Fax: +1 281 295 5899
Toll Free: 1 800 862 0200

LATIN AMERICA/MEXICO
Tel: +55 11 5188 8166
Fax: +55 11 5188 8169

ASIA PACIFIC
Tel: +86 (0)21 6489 7570
Fax: +86 (0)21 6442 6498

INDIA
Tel: +91 22 39342700
Fax: +91 22 39342701

MIDDLE EAST
Tel: +971 6 5570730
Fax: +971 6 5571242

TECHNICAL CENTERS

Servomex Group Limited
Crowborough
East Sussex, TN6 3FB
UK
Tel: +44 (0)1892 652181
Fax: +44 (0)1892 662253

Servomex Company Inc
4 Constitution Way
Woburn, MA 01801 1087
USA
Tel: +1 781 935 4600
Fax: +1 781 938 0531
Toll Free: 1 800 433 2552

SYSTEMS ENGINEERING CENTERS

Crowborough, UK Tel: +44 (0)1892 652181
Houston, USA Tel: +1 281 295 5800
Shanghai, China Tel: +86 (0)21 6489 7570
Mumbai, India Tel: +91 22 39342700

