

# Orion-2C, Orion-2D, Orion-3A & MPV-10K<sup>\*</sup>

---

*Pneumatic Pressure Controllers*

## Adjustment & Maintenance Manual



Genuine Quality, Proven Performance.

Condec Sales Phone Number: (888) 295-8475  
Condec Web Site: [www.4condec.com](http://www.4condec.com)

\*Patent No. 4,698,998

68859

# Contents

---

<b>About This Manual .....</b>	<b>1</b>
<b>1.0 Introduction .....</b>	<b>1</b>
<b>2.0 Maintenance .....</b>	<b>2</b>
2.1 O-ring Repair Kit Data .....	2
2.2 Recommended O-ring materials .....	2
2.3 ORION Manifold - Valve Seat Removal .....	3
2.4 ORION Manifold - Vernier Control Disassembly .....	4
2.5 ORION Manifold - Vernier Control Reassembly .....	4
2.6 ORION Manifold - Valve Seat Replacement .....	5
2.7 MPV-10K Manifold - Valve Seat Removal .....	6
2.8 MPV-10K Manifold - Valve Seat Replacement .....	7
2.9 ORION Manifold - Valve Adjustment Procedure (Customer Installation) .....	7
2.10 MPV-10K Manifold - Valve Adjustment Procedure (Customer Installation) .....	8
2.11 Recommended Mounting Patterns .....	9
2.12 ORION-2C Valve Assembly (55283) Parts List .....	10
2.13 ORION-2D Valve Assembly (55286) Parts List .....	13
2.14 ORION-3A Valve Assembly (55287) Parts List .....	16
2.15 MPV-10K Valve Assembly Parts List .....	19
<b>3.0 Specifications .....</b>	<b>22</b>
3.0.1 ORION-2C (PN 55283) .....	22
3.0.2 ORION-2D (PN 55286) .....	22
3.0.3 ORION-3A (PN 55287) .....	22
3.0.4 MPV-10K .....	22
<b>Orion/MPV-10K Warranty and Return Policy .....</b>	<b>23</b>
<b>Orion/MPV-10K Return Material Authorization Form .....</b>	<b>24</b>

# About This Manual

---

The ORION/MPV-10K is a pneumatic pressure controller with precision vernier. A rugged, compact controller manufactured by Condec, designed to provide ease of operation and installation, by a qualified technician.

Equipped to perform and be maintained on-site, these controllers have proven to substantially reduce the cost, system down-time and man-hours of labor normally associated with these routine service functions.

The patented controller was designed as an all mechanical device that has been factory adjusted and ready for on-site installation.

This manual has been written to give the user a simple and clear explanation of how to operate, and troubleshoot these controllers.



## Warning

*Before attempting to use either style, Pressure Controller, the following instructions must be carefully read and understood by personnel utilizing the equipment. This is a high-pressure system. It is strongly recommended that only personnel formally trained in the use of pneumatic pressure equipment be permitted to operate it. Potentially dangerous conditions could be produced through negligent handling or operation of the valve due to the high pressure used within the unit.*

*These units are strictly for use with pneumatic pressures. Erroneous readings and potential damage could result from the introduction of hydraulic fluids into the internal valve body.*



Authorized distributors and their employees can view or download this manual from the Condec distributor site at [www.4condec.com](http://www.4condec.com).

## 1.0 Introduction

---

The ORION/MPV-10K represents the latest in technology, offering a combination of features, performance, versatility and reliability not previously available in a pneumatic pressure controller. Some of the more outstanding features are listed below:

- Simple Operation: Accompanying operator's manual provides clear, concise instructions for system operation.
- ORION-2C, ORION-2D, ORION-3A: To obtain a specific pressure, either the Inlet Pressure valve or the Vent (outlet) valve (two outer valves) may be used since both provide precise control. As the pressure approaches the desired value, the valve being used for control should be slowly rotated clockwise to its closed position. With a little experience, pressure values very close to the desired final value may be quickly achieved. To obtain exact final pressure, slowly rotate the Vernier Control (middle) Knob in the desired direction, clockwise to increase pressure.
- MPV-10K: The pressure valve will begin to open when it is turned counter clockwise approximately 15 degrees. Full open position of the valves is achieved with a maximum of 3 1/2 turns from the closed position. The valve has a fine adjustment sensitivity. Very low torque is required to turn the vernier, so use fingertip adjustment.
- Safe, Clean Operation: All pressure components are made of brass, aluminum or stainless steel and proof-tested to at least 150% of maximum operating pressure.

The heart of the ORION controllers are the two micro-metering valves and the vernier provided for control of pressure. Overpressure protection must be customer provided, if required, by a fully adjustable pressure regulator which is manually set to limit the system input pressure. The ORION/MPV-10K is designed for compatibility with Nitrogen and shop air. Other O-ring materials are available through special ordering or repair kits.

## 2.0 Maintenance

---

This section outlines the mechanical repair procedures for the ORION/MPV-10K pressure source. The repair procedures cover the major components and subassemblies which are critical to the proper functioning of the calibrators and that will likely need periodic maintenance over the life of the unit. Only those persons who are formally trained as skilled technicians should attempt to repair these units. All relevant safety precautions should be observed due to the presence of high-pressure cylinders.

### 2.1 O-ring Repair Kit Data

O-ring repair kits:                   Nitrile Buna - N (PN 58499)  
  Ethylene - Propylene (PN 58506)  
  Silicone (PN 58509)  
  Neoprene (PN 58515)  
  Fluorocarbon "Viton" (PN 55277)

May be used with:                   ORION-2C Pneumatic Pressure Controller (PN 55283)  
  ORION-2D Pneumatic Pressure Controller (PN 55286)  
  ORION-3A Pneumatic Pressure Controller (PN 55287)  
  MPV-10K Valve Assemblies - (all Part Numbers)

**NOTE:** A small coating of Fluorinated Krytox grease (PN 55593) should be applied to both sides of O-ring prior to installation.

### 2.2 Recommended O-ring materials

**NOTE:** Ratings are recommended for use in the Condec products and are meant to be used only as a guide. Based on your application you may need to do testing. The O-ring material applications listed below are for reference only and are not to be used in the valves.

#### Nitrile Buna - N (BN)

The standard for most general applications (petroleum-based lubricants, hydraulic oils, gasoline, fuels, alcohol, LP gases, water, and many other media).

Temperature range:                   -65 to +300 F

Pressure rating:                      0-6000 PSI

#### Neoprene (C)

For refrigeration (freon gases, carbon dioxide gases, chlorine, ozone, sunlight exposure. FDA approved for food and beverage, odorless, tasteless, non toxic).

Temperature range:                   -80 to +260 F

Pressure rating:                      0-6000 PSI

#### Ethylene-Propylene (EP)

For hot water, steam, acids, alcohols, alkalis, ketones, phosphate, and brake fluids.

Temperature range:                   -67 to +302 F

Pressure rating:                      0-6000 PSI

#### Fluorocarbon "Viton" (V)

High temperature compatible with wide range of fluids and chemicals. Acids, oils, fuels, solvents and gases.

Temperature range:                   -65 to +500 F

Pressure rating:                      0-10000 PSI

## Silicone (S)

For high temperature applications. Compatible with air, oxygen, ozone and others.

Temperature range: -85 to +482 F

Pressure rating: 0-3000 PSI

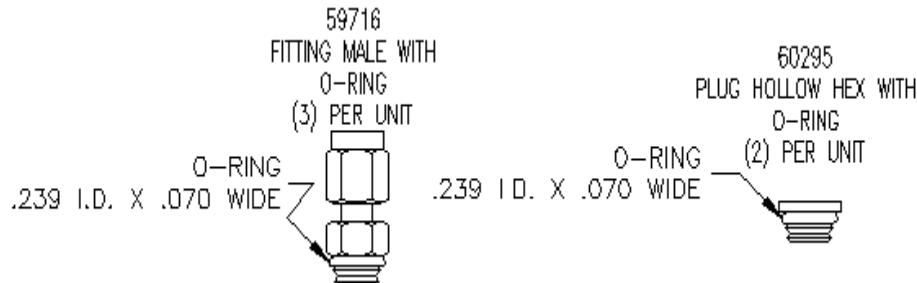

Figure 2-1. Additional ORION-2C O-ring Replacement Parts

## 2.3 ORION Manifold - Valve Seat Removal

(ORION-2C: Refer to the List of Parts - Table 2-1 on page 10, and Exploded View - Figure 2-6 on page 12)

(ORION-2D: Refer to the List of Parts - Table 2-2 on page 13, and Exploded View - Figure 2-8 on page 15)

(ORION-3A: Refer to the List of Parts - Table 2-3 on page 16, and Exploded View - Figure 2-10 on page 18)

Tools required:

- A/R solvent (de-natured alcohol)
- socket wrench
- 3/4" socket
- needle housing socket (PN 65580)
- isolation valve needle housing socket (PN 68509)
- hex wrench (.050")
- hex wrench (.061")
- needle-nose pliers
- tube fluorinated krytox grease (PN 55593)
- hand drill
- No. 43 drill
- No. 4-40 tap
- tap handle
- small hammer

### Procedure:

1. Secure the manifold by its center portion, in a bench vise, with the valve knobs pointing upward.
2. Using the .061" hex wrench, loosen and remove the knob inserts (4), as well as, the nylon washer (33) from the pressure and vent valve stems.
3. Using the .050" hex wrench, loosen and remove the setscrew (34) and lock nut (2).
4. Loosen the 3/4" lock nuts (1) on the *COARSE* (inlet pressure) and *VENT* valve threaded needle housings (10).
5. Using the needle housing socket (65580) and socket wrench, loosen and remove the needle/housing assembly (10,11).
6. To disassemble the *ISOLATION* valve(s), first remove the valve needle (18) by turning the gear (6) clockwise.
7. Loosen and remove the valve housing(s) (19) using the isolation valve housing removal socket (68509), and socket wrench.
8. Remove the valve stem seat(s) (8) and valve needle seat(s) (9) by using the needle-nose pliers.
9. Remove the inner and outer O-ring(s) (28, 27) and back-up ring(s) (31, 30) from the valve stem seats and wash all parts in solvent.
10. To remove valve seats (7) from either the *COARSE* (inlet pressure), *VENT* or *ISOLATION* valve(s), try blowing compressed air through the inlet and outlet fittings. Otherwise, the center holes have to be drilled and a tap used to extract the seat (steps 11-14).

11. Using the hand drill, with the No. 43 bit, carefully drill out the seat hole, ensuring that the drill does not touch the hole in the manifold housing directly beneath the seat (7).
12. Blow out any chips from the seat area using compressed air.
13. While holding the 4-40 tap perpendicular to the seat, slowly turn until the tap starts to engage the seat.
14. When the tap has engaged into the seat, use a small hammer and gently knock upward against the tap handle to extract the seat.
15. After the seat has been removed, blow any remaining chips from the seat area.

## 2.4 ORION Manifold - Vernier Control Disassembly

Tools required:     A/R solvent (de-natured alcohol)  
                           open end wrench (1-1/4")  
                           flat blade screwdriver  
                           socket wrench  
                           isolation valve needle housing socket (PN 68508)  
                           isolation valve needle housing socket (PN 68509)

1. With the manifold housing mounted in a vise, turn the *VERNIER* shaft (14) clockwise until the piston is bottomed.
2. Loosen and remove the end cap (13) using a 1-1/4" wrench. At certain points during removal the end cap will appear to lock up. If this occurs, rotate the shaft clockwise until the end cap is free to turn.
3. Remove the O-ring (29) from the end cap.

ORION-3A: Also remove the backup washer (38) from the end cap.

4. Remove the self-sealing screw (36) that acts as the piston key.
5. Remove the piston (15) by partially screwing in the threaded end of the *VERNIER* shaft (14) and pulling.
6. Remove the O-ring (32) from the piston groove.
7. To disassemble the end cap/shaft assembly, mount the end cap in the vise.
8. Loosen and remove the locknut (20) using the isolation valve housing socket (PN 68509) and socket wrench.
9. ORION-2C, ORION-2D: Loosen and remove the end bushing (12) using the same socket. Remove the shaft (14). Remove the mylar bearing washer (41 or 42) from both sides of the shaft flange.

ORION-3A: Loosen and remove the end bushing (12) using the isolation valve housing socket (PN 68508) and socket wrench. Remove the shaft (14). Remove the ball bearings (41) from both sides of the shaft flange.

10. Use a small pick or screwdriver to remove the O-ring (27) from the inner groove of the end cap (13).  
 ORION-3A: Also remove backup retainer (39) from inner groove of the end cap (13).
11. Wash all parts in solvent and blow dry with compressed air.

## 2.5 ORION Manifold - Vernier Control Reassembly

(ORION-2C: Refer to the List of Parts - Table 2-1 on page 10, and Exploded View - Figure 2-6 on page 12)

(ORION-2D: Refer to the List of Parts - Table 2-2 on page 13, and Exploded View - Figure 2-8 on page 15)

(ORION-3A: Refer to the List of Parts - Table 2-3 on page 16, and Exploded View - Figure 2-10 on page 18)

Tools required:     tube fluorinated krytox grease (PN 55593)  
                           open end wrench (1-1/4")  
                           flat blade screwdriver  
                           socket wrench  
                           isolation valve needle housing socket (PN 68508)  
                           isolation valve needle housing socket (PN 68509)  
                           torque wrench

1. Coat all O-rings and backup washer/retainers with Krytox grease before installing. Make sure that the O-rings and backup rings/washers are installed in the proper order.
2. Install the small O-ring (27) into the end cap inner groove.

ORION-3A: Also install backup retainer (39) in inner groove of the end cap (13).

3. ORION-2C, ORION-2D: Add mylar washers (41 or 42) to each side of shaft (14). Apply a small amount of Krytox grease to the shaft threads and install the shaft (14) into the end cap (13).

**NOTE:** Part number and quantity will vary. Washers are used to adjust vertical play in shaft (14). Try one washer (41) on each side to start.

Install the end bushing (12) and tighten until snug using the isolation valve needle housing socket (PN 68509) and socket wrench.

ORION-3A: Hold shaft (14) vertically with end that goes through end bushing (12) toward ceiling. Place light coating of grease on threads of shaft. Place thick coating of grease on top of shaft bearing surface. Allowing grease to hold ball bearings in place. Slide end bushing (12) over top of shaft and down to contact top of ball bearings. Rotate shaft assembly 180°, placing end bushing towards the floor. Be careful not to displace ball bearings. Place thick coating of grease on shaft and bearing surface. Place sixteen chrome ball bearings (41) on greased surface, allowing grease to hold them in place. Install shaft with bearings into end cap. Install the end bushing and tighten until snug using the isolation valve needle housing socket (PN 68508) and socket wrench.

4. ORION-2C, ORION-2D: Feel vertical motion of shaft (14). If motion exists, add thicker washer (42) at step 3, otherwise continue to step 5.

ORION-3A: Tighten so that shaft rotates, but should be firm. Verify no up and down movement. If there is up and down movement, retighten end bushing.

5. Install the locknut (20) into end cap (13) and using the isolation valve needle housing socket (PN 68509) and torque wrench. Torque to approximately 325 in. lbs. (may not get to torque on all sub-assemblies).
6. Install the O-ring (32) in the piston groove and install the piston (15) into the *VERNER* cavity. Ensure that the piston key way is facing the hole into which the self-sealing screw (36) is assembled.
7. Install the self-sealing screw (36) and tighten until snug.
8. Install the O-ring (29) on the end cap/shaft assembly, install into manifold and tighten until snug. ORION-3A: Also install backup washer (38) on the end cap/shaft assembly.

## 2.6 ORION Manifold - Valve Seat Replacement

(ORION-2C: Refer to the List of Parts - Table 2-1 on page 10, and Exploded View - Figure 2-6 on page 12)

(ORION-2D: Refer to the List of Parts - Table 2-2 on page 13, and Exploded View - Figure 2-8 on page 15)

(ORION-3A: Refer to the List of Parts - Table 2-3 on page 16, and Exploded View - Figure 2-10 on page 18)

Tools required:

- A/R solvent (de-natured alcohol)
- socket wrench
- 3/4" socket
- female socket (PN 65581)
- needle housing socket (PN 65580)
- isolation valve needle housing socket (PN 68509)
- hex wrench (.061")
- hex wrench (.050")
- torque wrench
- needle-nose pliers
- tube Fluorinated Krytox grease (PN 55593)
- No. 43 drill

1. Install a new seat (7) by placing it into the seat well with the needle-nose pliers. Ensure that the seat is centered within the cavity and gently tap it with a blunt end of a drill bit to install.
2. Install the valve needle seat (9) with the smaller diameter end facing outward.
3. Install new O-rings (28, 27) inside and outside of the valve stem seat (8). Coat all O-rings and back-up rings (30, 31) with fluorinated Krytox grease before installation. Make sure that the rings are installed in the proper order.
4. Install the valve stem seat (8) by grasping the small diameter end with the needle-nose pliers and positioning in the valve cavity, then properly seat by gently pushing with the blunt end of a drill bit.
5. For the two outer valves, disassemble the valve needle (11) from its housing (10) and check for any burrs or dirt on the threads which might interfere with smooth operation.

6. Clean both the needle (11) and housing (10) in solvent, dry the parts and apply a small amount of fluorinated Krytox grease to the needle threads before reassembly.
7. Assemble the needle into the valve housing and turn it until it stops.
8. Reinstall the needle/housing assembly into the valve cavity until finger tight.
9. Mount the manifold body (16) in a vise. For the pressure and vent valves (outer) only, torque the needle/housing assembly to 325 in. lbs. using the needle housing socket (PN 65580) and torque wrench.
10. Install the housing lock nuts (1) onto the housing (10) and tighten until snug with the 3/4" socket.
11. Using the .050" hex wrench, install and tighten the lock nut (2) and set screw (34).
12. Install the knob insert (4) and nylon washer (33) over the needle shaft (11), align the set screws (23) with the indents and tighten with the .061" hex wrench.
13. For the *ISOLATION* or *VACUUM* (inner) valves, install the needle housing (19) and tighten until snug using the housing installation socket (PN 68509) and torque wrench (there is no specified torque, so use care when tightening so as not to break the socket nibs).
14. Install the gear (6) over the isolation or vacuum (inner) valve needle (18) shaft, align the set screws (26) with the indents and tighten with the .061" hex wrench.
15. Apply a small amount of fluorinated Krytox grease to the threads of the isolation or vacuum (inner) valve needle(s) (18) and install into the valve by turning counter-clockwise. Rotate the gear counter-clockwise until the needle just stops at the seat.

## 2.7 MPV-10K Manifold - Valve Seat Removal

(MPV-10K - refer to the list of parts - Table 2-4 on page 19, and Figure 2-12 on page 21)

Tools required:

- A/R solvent (de-natured alcohol)
- socket wrench
- 3/4" socket
- needle housing socket (PN 65580)
- isolation valve needle housing socket (PN 68509)
- hex wrench (.050")
- hex wrench (.061")
- needle-nose pliers
- tube fluorinated krytox grease (PN 55593)
- hand drill
- No. 43 drill
- No. 4-40 tap
- tap handle
- small hammer

1. Secure the manifold in a bench vise by its center portion with the valve knob pointing upward.
2. Using the .061" hex wrench, loosen and remove the knob (15) and the nylon washer (14) from the pressure valve stem (3) or (6).
3. Using the .050" hex wrench, loosen and remove the set screw (13) and lock nut (12).
4. Loosen the 3/4" lock nut (11) on the pressure valve threaded needle housing (2).
5. Using the needle housing socket (PN 65580) and socket wrench, loosen and remove the needle/housing assembly (2,3) or (2,6).
6. Remove the valve stem seat (10) and valve needle seat (5) by using the needle-nose pliers.
7. Remove the inner and outer O-rings and back-up rings (7,9) from the valve stem seats and wash all parts in solvent.
8. To remove valve seat (4), blow compressed air through the inlet and outlet fittings. If this is unsuccessful, the center holes will have to be drilled and a tap used to extract the seat (steps 9 - 12).
9. Using the hand drill with No. 43 bit, carefully drill out the seat hole, ensuring that the drill does not touch the hole in the manifold housing directly beneath the seat (4).
10. Blow out any chips from the seat area using compressed air.
11. While holding the 4-40 tap perpendicular to the seat, steadily and slowly turn until the tap starts to engage the seat.



12. When the tap has engaged into the seat, use a small hammer and gently knock upward against the tap handle to extract the seat.
13. After the seat has been removed, blow any remaining chips from the seat area.

## 2.8 MPV-10K Manifold - Valve Seat Replacement

(MPV-10K - refer to the list of parts - Table 2-4 on page 19, and Figure 2-12 on page 21)

Tools required:     A/R solvent (de-natured alcohol)  
                           socket wrench  
                           3/4" socket  
                           needle housing socket (PN 65580)  
                           hex wrench (.061")  
                           torque wrench  
                           needle-nose pliers  
                           tube Fluorinated Krytox grease (PN 55593)  
                           No. 43 drill

1. Install a new seat (4) by placing it into the seat with the needle-nose pliers. Ensure that the seat is centered within the cavity and gently tap it with a blunt end of a drill bit to install.
2. Install the valve needle seat (5) with the smaller diameter end facing outward.
3. Install new O-rings inside and outside of the valve stem seat (5). Coat all O-rings and back-up rings (7,9) with Krytox grease before installation. Make sure that the O-rings and back-up rings are installed in the proper order.
4. Install the valve stem seat (10) by grasping the small diameter end with the needle-nose pliers and positioning in the valve cavity, then gently pushing with the blunt end of a drill bit.
5. Disassemble the valve needle (3 or 6) and valve needle housing (2) and check for any burrs or dirt on the threads which might interfere with smooth operation.
6. Clean both the valve needle (3 or 6) and valve needle housing (2) in solvent, dry the parts and apply a small amount of Krytox grease to the valve needle threads before re-assembly.
7. Assemble the valve needle (3 or 6) into the valve needle housing (2) and turn until it stops.
8. Reinstall the needle/housing assembly into the valve cavity until finger tight.
9. Mount the manifold body (1) in a vise. Torque the needle/housing assembly to 325 in. lbs. using the needle/housing socket (PN 65580).
10. Install the housing locknut (11) onto the valve needle housings (2) and tighten until snug with the 3/4" socket.
11. Using the .050" hex wrench, install and tighten the lock nut (12) and set screw (13).
12. Install the nylon washer (14) and knob (15) over the valve needle (3 or 6) shaft, align the set screws (16) with the indents and tighten with the .061" hex wrench.

## 2.9 ORION Manifold - Valve Adjustment Procedure (Customer Installation)

(ORION-2C Refer to the List of Parts - Table 2-1 on page 10, and Exploded View - Figure 2-6 on page 12)

(ORION-2D Refer to the List of Parts - Table 2-2 on page 13, and Exploded View - Figure 2-8 on page 15)

(ORION-3A Refer to the List of Parts - Table 2-3 on page 16, and Exploded View - Figure 2-10 on page 18)

**NOTE:** *The following minimum customer supplied input pressure equipment is required. Input supply pressure with a supply gauge and pressure regulator.*

Tools required:     hex wrench (.050")  
                           hex wrench (.061")

1. Turn the supply pressure regulator off and vent manifold.
2. If not already done, remove the ORION input and vent valve (outer) knobs (3) using the .061" hex wrench.
3. Using a .050" hex wrench, loosen the set screw (34) on each ORION input and vent valve locknut (2) and turn each locknut clockwise to its stop.

4. Check to see that each knob insert (4) is securely fastened to the ORION input and vent valve shaft (11). If it is loose, re-tighten the set screws (23) with the .061" hex wrench.
5. Close the input valve by turning the knob insert (4) clockwise until you feel the valve needle seat on the O-ring (valve is now in closed position).
6. Rotate gear(s) (small gears with 18 teeth) on isolation valve(s), counter clockwise (gear[s] will rotate towards valve body) until they stop. Then rotate each gear clockwise 1/2 turn to open isolation valves.
7. Turn the supply pressure regulator to increase the supply pressure to between 80% and 100% of customer's line pressure (ORION-2C or ORION-3A: maximum 3000 PSI; ORION-2D: maximum 300 PSI).
8. Open the *VENT* valve to atmosphere to release line pressure, then close the *VENT* valve.
9. Slowly open the input valve by turning the knob insert (4) counter-clockwise until you notice the input pressure gauge pressure increase. Then turn the knob insert (4) slightly clockwise until the pressure stops rising.
10. Mark a radial line at the 12 o'clock position on the knob insert.
11. Turn the knob insert (4) clockwise to move the mark to the 6 o'clock position.
12. Turn the locknut (2) counter-clockwise until it contacts the bottom of the stop washer. Tighten the set screw (34) on the locknut with the .050" hex wrench.
13. Install the input valve knob (3) on the knob insert (4) and engage its gear (5) with the smaller isolation valve gear (6). Turn the knob clockwise until the isolation valve is slightly snug.

**CAUTION:** *do not use excessive torque when doing this. The seat may be damaged.*

14. Remove the input valve knob (3). Align the set screws (25) with the indentations on the knob insert. Install the knob on the knob insert (4) while engaging the knob gear (5) with the isolation valve gear (6).
15. Tighten the set screws (25) with the .061" hex wrench. The input valve is now adjusted.
16. To adjust the *VENT* valve (output). Close the input valve by turning the output valve knob clockwise.
17. Close the *VENT* valve knob insert (4) clockwise until slightly snug.
18. With the supply pressure at customer's 100% line pressure (ORION-2C or ORION-3A: maximum 3000 PSI; ORION-2D: maximum 300 PSI). Open the *COARSE* valve until the indicated pressure stabilizes and then close the *COARSE* valve.
19. Slowly turn the *VENT* valve (output) knob insert (4) counter-clockwise until you hear flow from the *VENT* valve, then turn the knob insert (4) slightly clockwise until the pressure stops decreasing.
20. Repeat steps 10 - 15 for the *VENT* valve, replacing the term "input valve" with "output valve."

## 2.10 MPV-10K Manifold - Valve Adjustment Procedure (Customer Installation)

(MPV-10K - Refer to the List of Parts - Table 2-4 on page 19, and Figure 2-12 on page 21)

**NOTE:** *Customer must supply, as a minimum, input supply pressure with a supply gauge and pressure regulator.*

Tools required:     hex wrench (.050")  
                           hex wrench (.061")

1. Turn the supply pressure regulator off.
2. If not already done, remove the MPV-10K knob (15) using the .061" hex wrench.
3. Using a .050" hex wrench, loosen the set screw (13) on the MPV-10K valve locknut (12) and turn locknut clockwise until it stops.
4. Align the set screws (16) with the indentations on the valve needle (3 or 6). Install the knob using the .061" hex wrench.
5. Turn the supply pressure regulator, to increase the supply pressure to between 80% and 100% of customer's line pressure (maximum 10,000 PSI). Let system settle for 5 minutes.

**NOTE:** *Some valves may not be recommended for 10000 PSI, because of O-ring material selection. See Section 2.2 on page 2.*

6. Slowly open the MPV-10K valve by turning the knob (15) counter-clockwise until you notice the pressure of the input pressure gauge increase. Then turn the knob slightly clockwise until the pressure stops rising.

7. Mark a radial line at the 12 o'clock position on the knob.
8. Turn the knob (15) clockwise to move the mark to the 6 o'clock position.
9. Turn the locknut (12) counter-clockwise until it contacts the bottom of the stop washer (14).
10. Remove the MPV-10K knob (15) using the .061" hex wrench.
11. Tighten the set screw (13) on the locknut with the .050" hex wrench.
12. Align the set screws (16) with the indentations on the valve needle (3 or 6). Install the knob (15) using the .061" hex wrench. The output valve is now adjusted.

## 2.11 Recommended Mounting Patterns

The following figures show recommended mounting patterns.

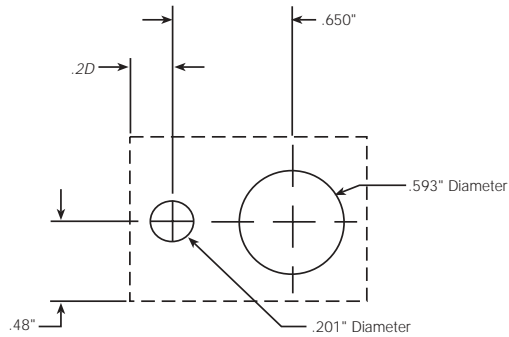

Figure 2-2. Recommended Hole Pattern for MPV-10K

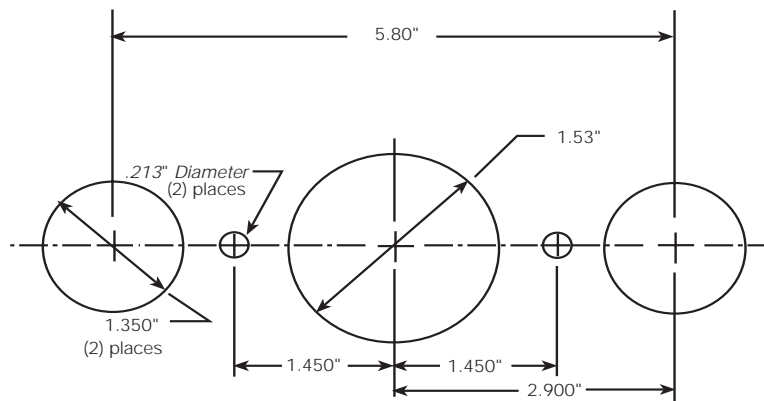

Figure 2-3. Recommended Hole Pattern for ORION-2C and ORION-2D

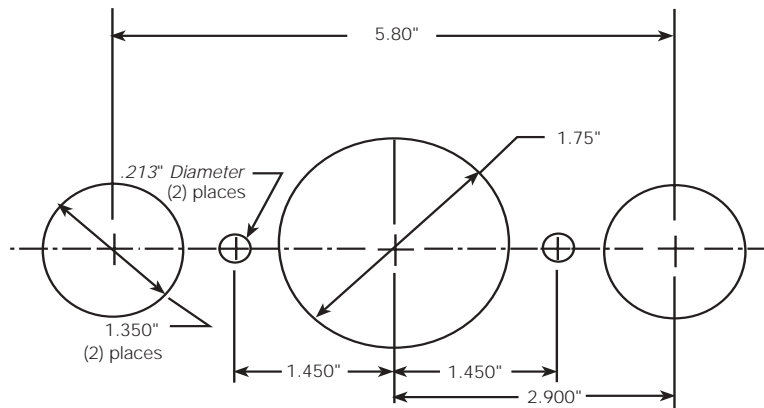

Figure 2-4. Recommended Hole Pattern for ORION-3A

## 2.12 ORION-2C Valve Assembly (55283) Parts List

The following table lists the component parts of the ORION-2C.

Ref Number	PN	Description	Quantity
1	57482	Nut,Valve Needle Housing	2
2	54401	Locknut	2
3	58079	Knob	2
4	57889	Knob,Insert	2
5	57256	Gear,Spur 40 Teeth	2
6	59233	Gear,Spur 18-tooth	2
7	55896	Valve Seat	4
8	59387	Valve Seat,Stem	4
9	59045	Valve,Needle Seat	4
10	54540	Housing,Valve Needle	2
11	59551	Valve Needle	2
12	57906	Bushing,End	1
13	59378	Cap,End	1
14	59495	Shaft	1
15	59241	Piston	1
16	55714	Body,Dual Valve	1
17	57580	Knob	1
18	55533	Valve Needle	2
19	55159	Housing,Valve Needle	2
20	56784	Locknut	1
21	59845	Plug,Expansion	14
23	59383	Setscrew,6-32NCx1/8 SST	4
24	58342	Screw,Cap Hex Socket Head, #2-56UNC-3A	6
25	59322	Setscrew,6-32NCx1/4 SST	6
26	59326	Setscrew,2-56NCx1/8, alloy steel	4
27	55554	O-ring, Buna N (Nitrile) 70 Durometer Color Black	5
28	55536	O-ring, Buna N (Nitrile) 70 Durometer Color Black	4
29	55573	O-ring, Buna N (Nitrile) 70 Durometer Color Black	1
30	60633	Retainer, Packing Backup	4
31	55570	Washer, Backing .04 Thick	4
32	55577	O-ring, Buna N (Nitrile) 70 Durometer Color Black	1
33	59245	Washer,#8 Screw Size .187, ID x .440 OD x .040 Thick Nylon	2
34	60202	Setscrew, hex	2
35	60837	Screw, MACH Pan Head	2
36	58976	Screw,Self Sealing	1
38	53308	Label	1
41	59878	Spacer .005 thk Mylar	2
42	59880	Spacer .007 thk Mylar	2

Table 2-1. ORION-2C Valve Assembly Parts List

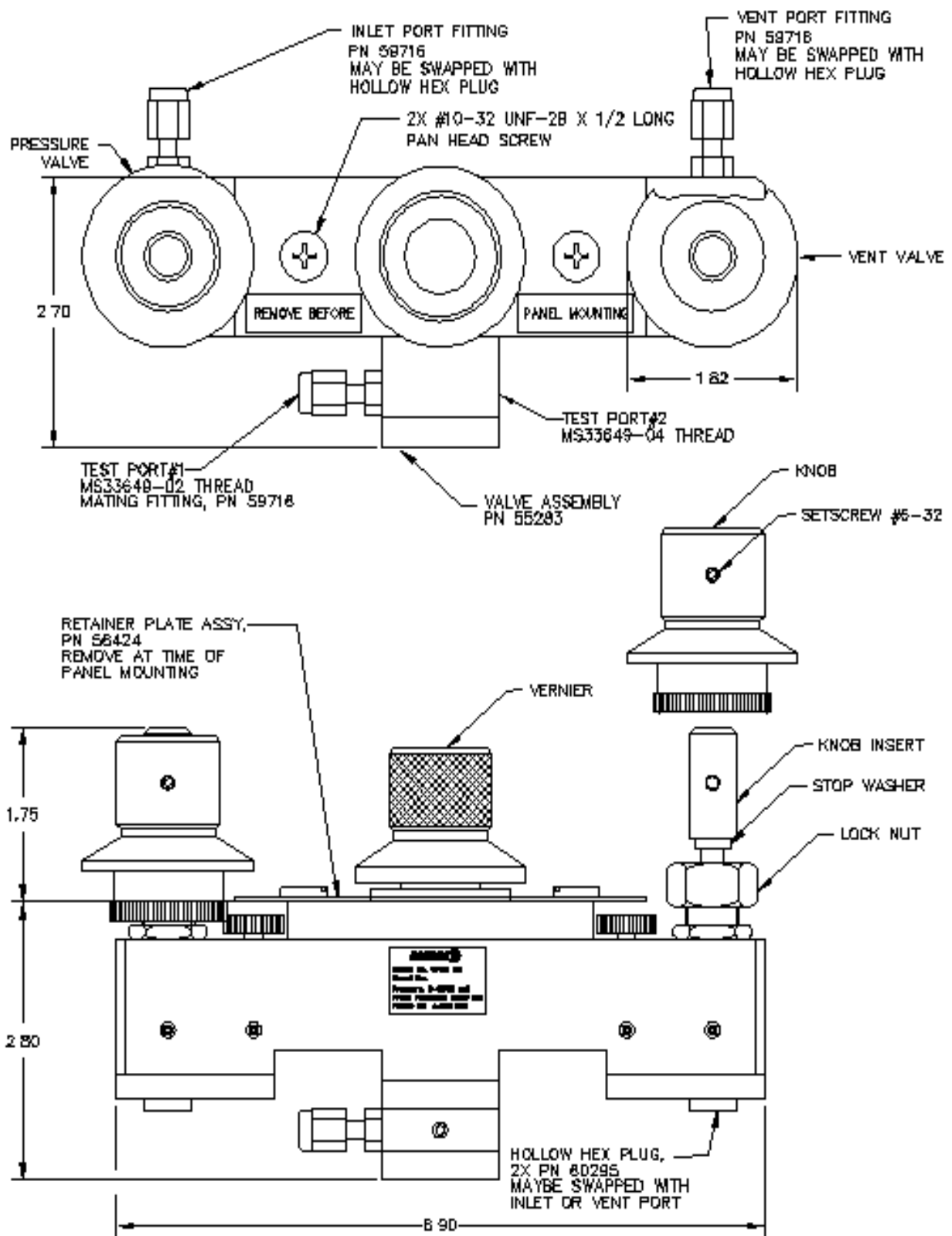

Figure 2-5. ORION-2C Valve Assembly (PN 55283) Mounting View

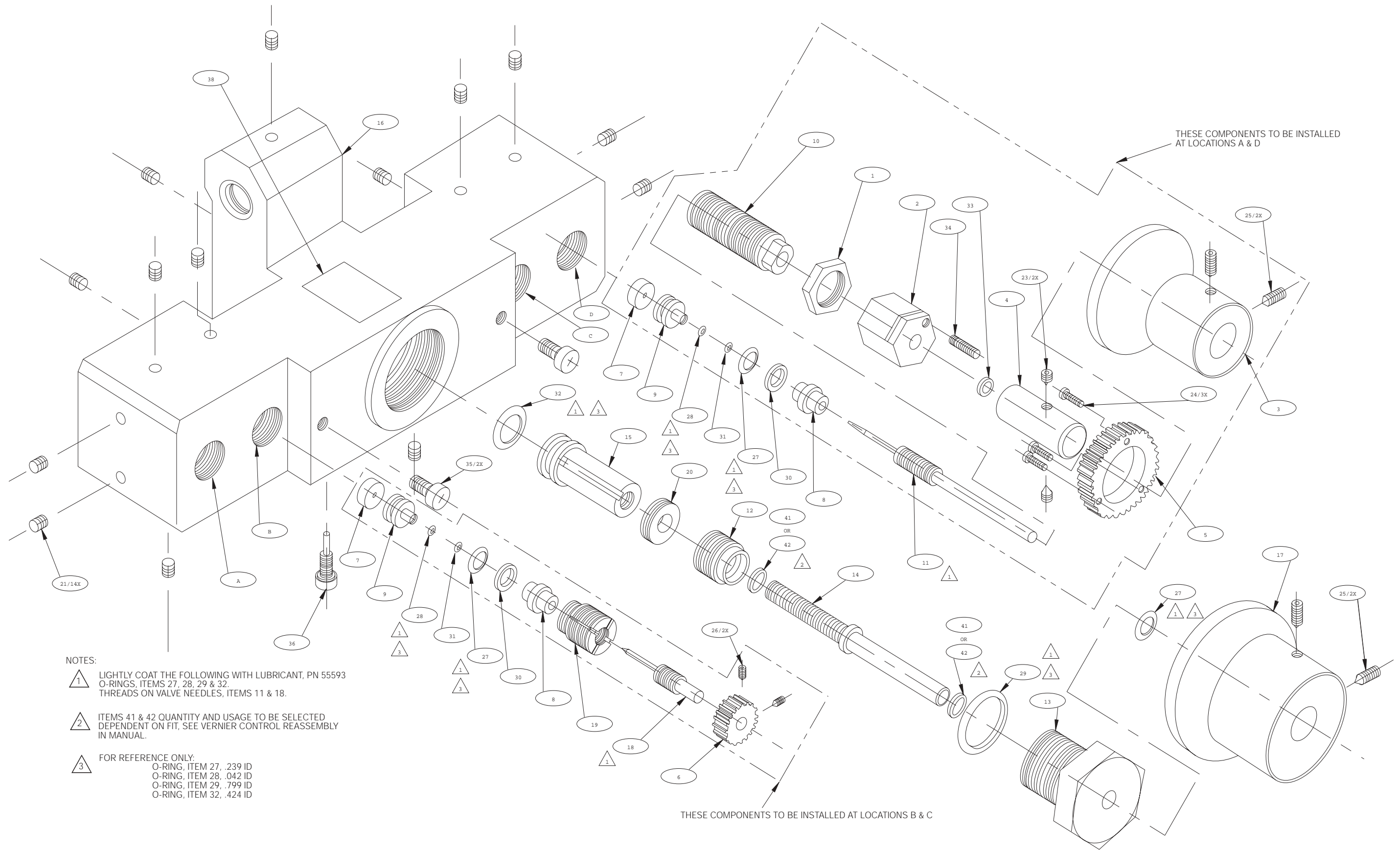

Figure 2-6. ORION-2C, Exploded View

## 2.13 ORION-2D Valve Assembly (55286) Parts List

The following table lists the component parts of the ORION-2D.

Ref Number	PN	Description	Quantity
1	57482	Nut,Valve Needle Housing	2
2	54401	Locknut	2
3	58079	Knob	2
4	57889	Knob,Insert	2
5	57256	Gear,Spur 40 Teeth	1
6	59233	Gear,Spur 18-teeth	1
7	55896	Valve Seat	3
8	59387	Valve Seat,Stem	3
9	59045	Valve,Needle Seat	3
10	54540	Housing, Valve Needle	2
11	59551	Valve Needle	2
12	57906	Bushing,End	1
13	59378	Cap, End	1
14	59495	Shaft	1
15	59241	Piston	1
16	56874	Body, Dual Valve	1
17	57580	Knob	1
18	55533	Valve Needle	1
19	55159	Housing, Valve Needle	1
20	56784	Locknut, 9/16-18UNF-3A, SST	1
21	58927	Screw, hex seal	6
23	59383	Setscrew, 6-32NCx1/8 SST	4
24	58342	Screw, Cap Hex Socket Head, #2-56UNC-3A	3
25	59322	Setscrew, 6-32NCx1/4 SST	6
26	59326	Setscrew, 2-56NCx1/8, alloy steel	2
27	55554	O-ring Buna N (Nitrile) Color Black	4
28	55536	O-ring Buna N (Nitrile) Color Black	3
29	55573	O-ring Buna N (Nitrile) Color Black	1
30	60633	Retainer, Packing Backup	3
31	55570	Washer, Backing	3
32	55577	O-ring Buna N (Nitrile) Color Black	1
33	59245	Washer	2
34	60202	Setscrew, hex	2
35	60837	Screw, MACH Pan Head	2
36	58976	Screw, Self Sealing	1
38	53308	Label	1
39	59738	Fitting, Male Connector 1/8 tube x 1/8 NPT brass	2
40	41944	Male Swivel Elbow 1/8 NPT x 5/32 tube O.D.	2

Table 2-2. ORION-2D Valve Assembly Parts List

Ref Number	PN	Description	Quantity
41	59878	Spacer .005 thk Mylar	2
42	59880	Spacer .007 thk Mylar	2
43	57699	Tube Male Connector 5/32 tube O.D. x 1/8 NPT	2

Table 2-2. ORION-2D Valve Assembly Parts List (Continued)

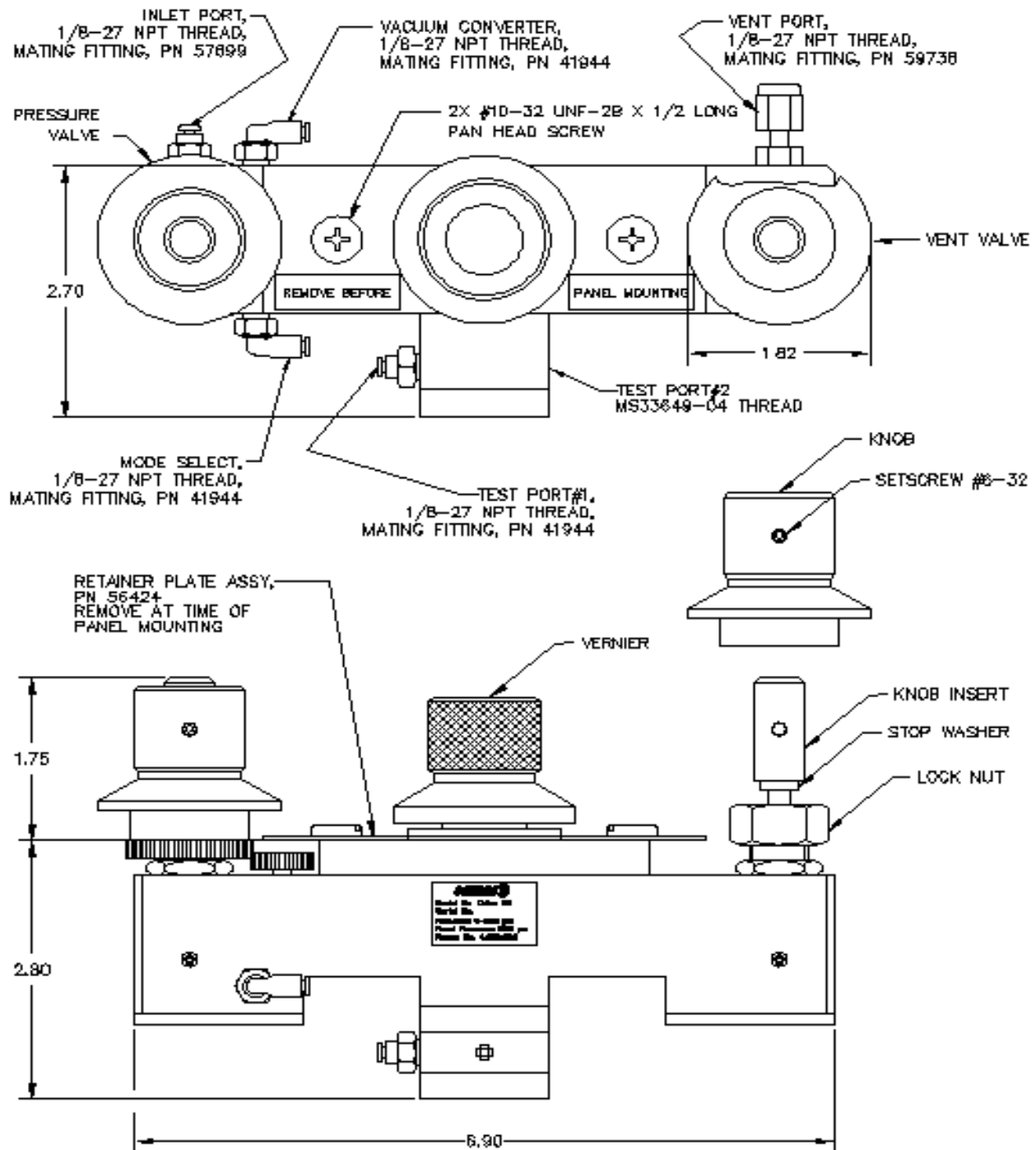
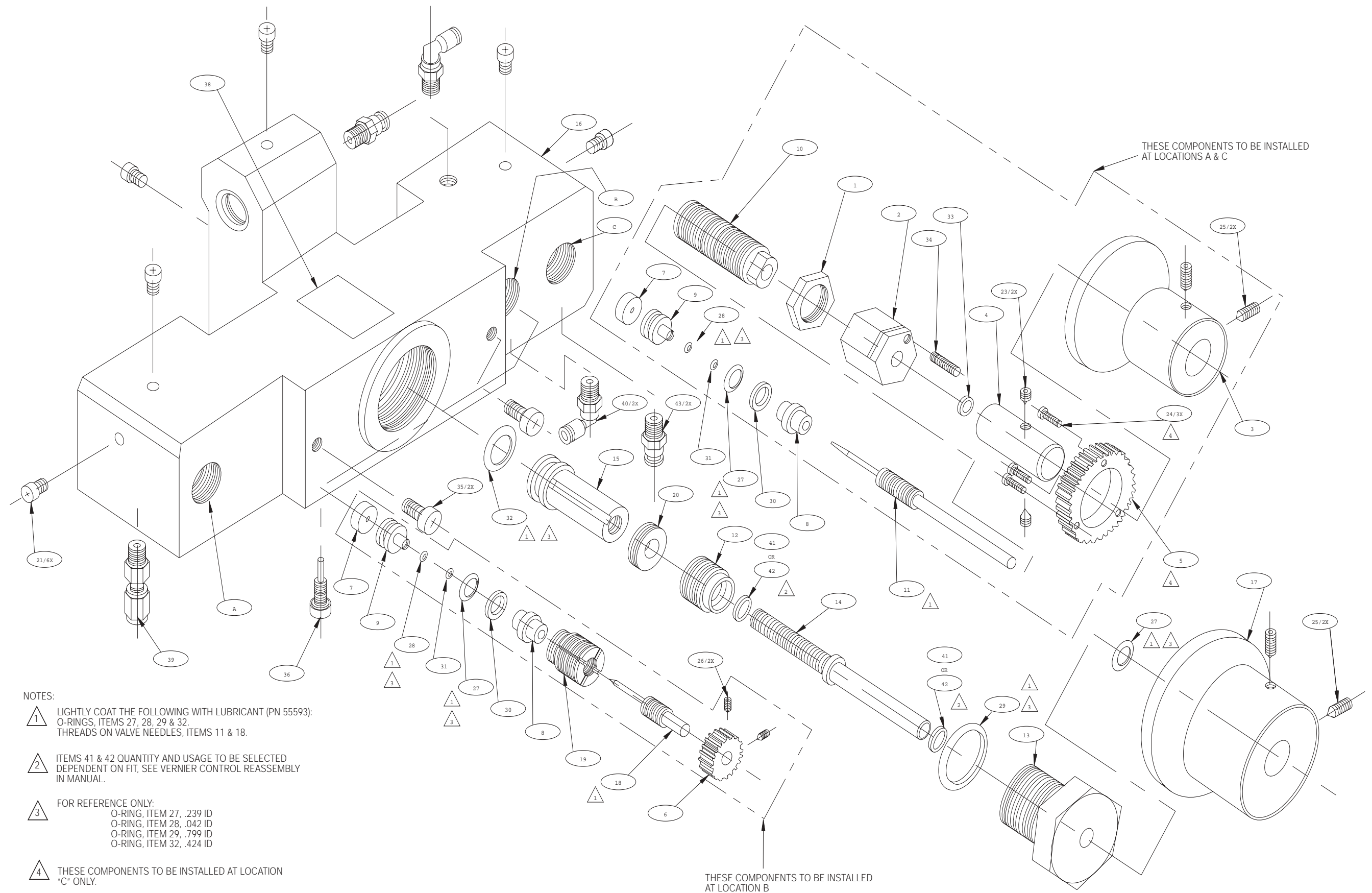

Figure 2-7. ORION-2D Valve Assembly (PN 55286) Mounting View





NOTES:

- 1 LIGHTLY COAT THE FOLLOWING WITH LUBRICANT (PN 55593):  
O-RINGS, ITEMS 27, 28, 29 & 32.  
THREADS ON VALVE NEEDLES, ITEMS 11 & 18.
- 2 ITEMS 41 & 42 QUANTITY AND USAGE TO BE SELECTED  
DEPENDENT ON FIT, SEE VERNIER CONTROL REASSEMBLY  
IN MANUAL.
- 3 FOR REFERENCE ONLY:  
O-RING, ITEM 27, .239 ID  
O-RING, ITEM 28, .042 ID  
O-RING, ITEM 29, .799 ID  
O-RING, ITEM 32, .424 ID
- 4 THESE COMPONENTS TO BE INSTALLED AT LOCATION  
\*C\* ONLY.

THESE COMPONENTS TO BE INSTALLED  
AT LOCATION B

Figure 2-8. ORION-2D, Exploded View

## 2.14 ORION-3A Valve Assembly (55287) Parts List

The following table lists the component parts of the ORION-3A.

Ref Number	PN	Description	Quantity
1	57482	Nut, Valve Needle Housing	2
2	54401	Locknut	2
3	58079	Knob	2
4	57889	Knob, Insert	2
5	57256	Gear, Spur 40 Teeth	2
6	59233	Gear, Spur 18 Teeth	2
7	55896	Valve Seat	4
8	59387	Valve Seat, Stem	4
9	59045	Valve, Needle Seat	4
10	54540	Housing, Valve Needle	2
11	59551	Valve Needle	2
12	57600	Bushing, End	1
13	58554	Cap, End	1
14	58699	Shaft	1
15	58597	Piston	1
16	59309	Body, Dual Valve	1
17	57580	Knob	1
18	55533	Valve Needle	2
19	55159	Housing, Valve Needle	2
20	56784	Locknut, 9/16-18UNF-3A, SST	1
21	58464	Setscrew, 12-24NC x 1/4, SST	14
22	58308	Ball, Tungsten carbide	14
23	59383	Setscrew, 6-32NCx1/8 SST	4
24	58342	Screw, Cap Hex Socket Head, #2-56UNC-3A	6
25	59322	Setscrew, 6-32NCx1/4 SST	6
26	59326	Setscrew, 2-56NCx1/8, alloy steel	4
27	55569	O-ring, Fluorocarbon (Viton) color black w/white dot	5
28	55552	O-ring, Fluorocarbon (Viton) color black w/white dot	4
29	58090	O-ring, Fluorocarbon (Viton) color black w/white dot	1
30	60633	Retainer, Packing Backup	4
31	55570	Washer, Backing	4
32	58045	O-ring, Fluorocarbon (Viton) color black w/white dot	1
33	59245	Washer, Nylon	2
34	60202	Setscrew, hex	2
35	60837	Screw, MACH Pan Head #10- 32NFx1/2 Phillips Head 300 Series SST	2
36	54905	Screw, Self Sealing	1
38	57027	Washer, backup	1
39	54448	Retainer, Packing backup	1

Table 2-3. ORION-3A Valve Assembly Parts List

Ref Number	PN	Description	Quantity
40	55615	O-ring, Fluorocarbon (Viton) color black w/white dot	1
41	58314	Ball, chrome, steel	32
42	59731	Male connector, 1/8 tube x 1/8 NPT, stainless steel	3

Table 2-3. ORION-3A Valve Assembly Parts List (Continued)

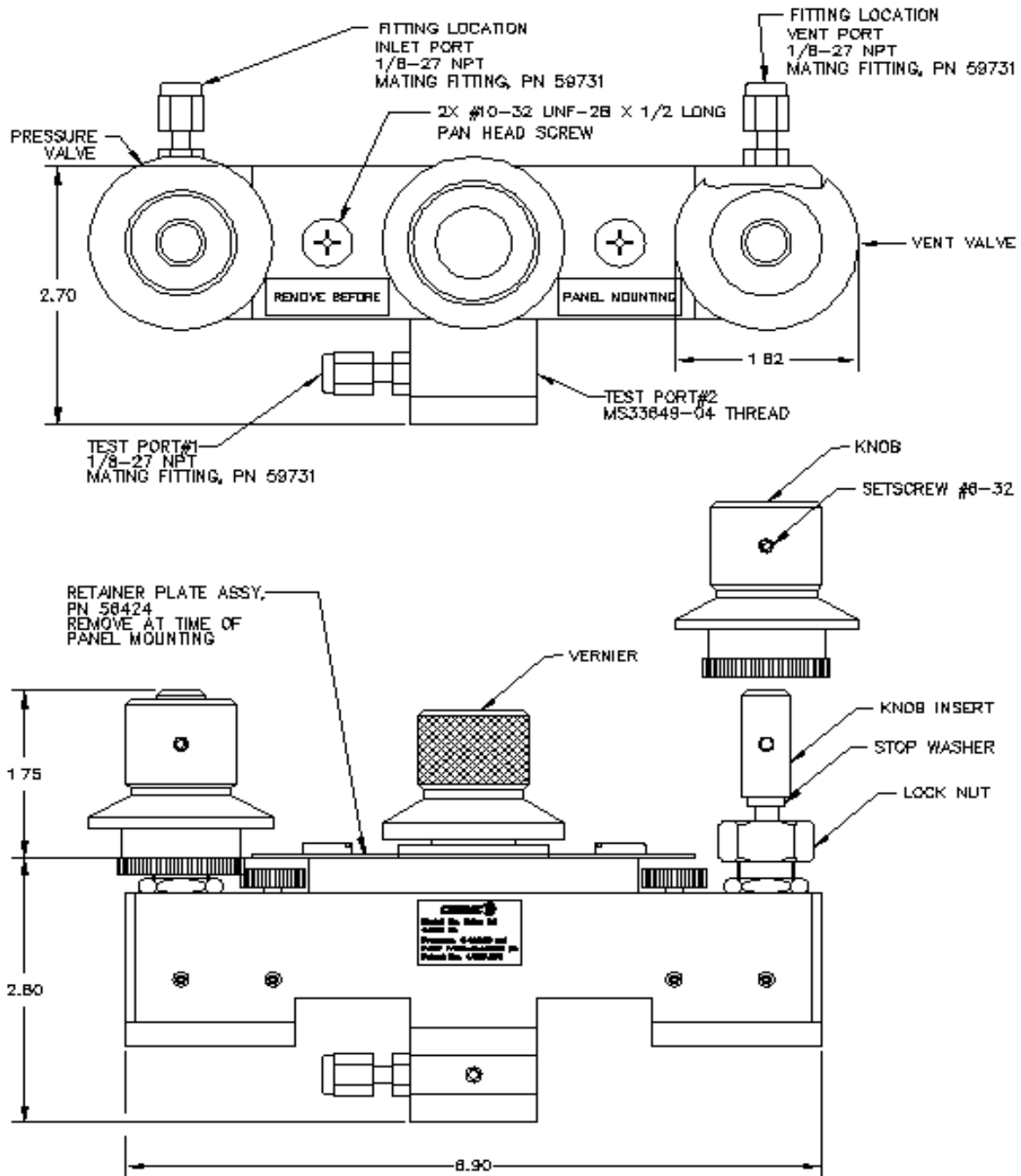

Figure 2-9. ORION-3A Valve Assembly (PN 55283) Mounting View

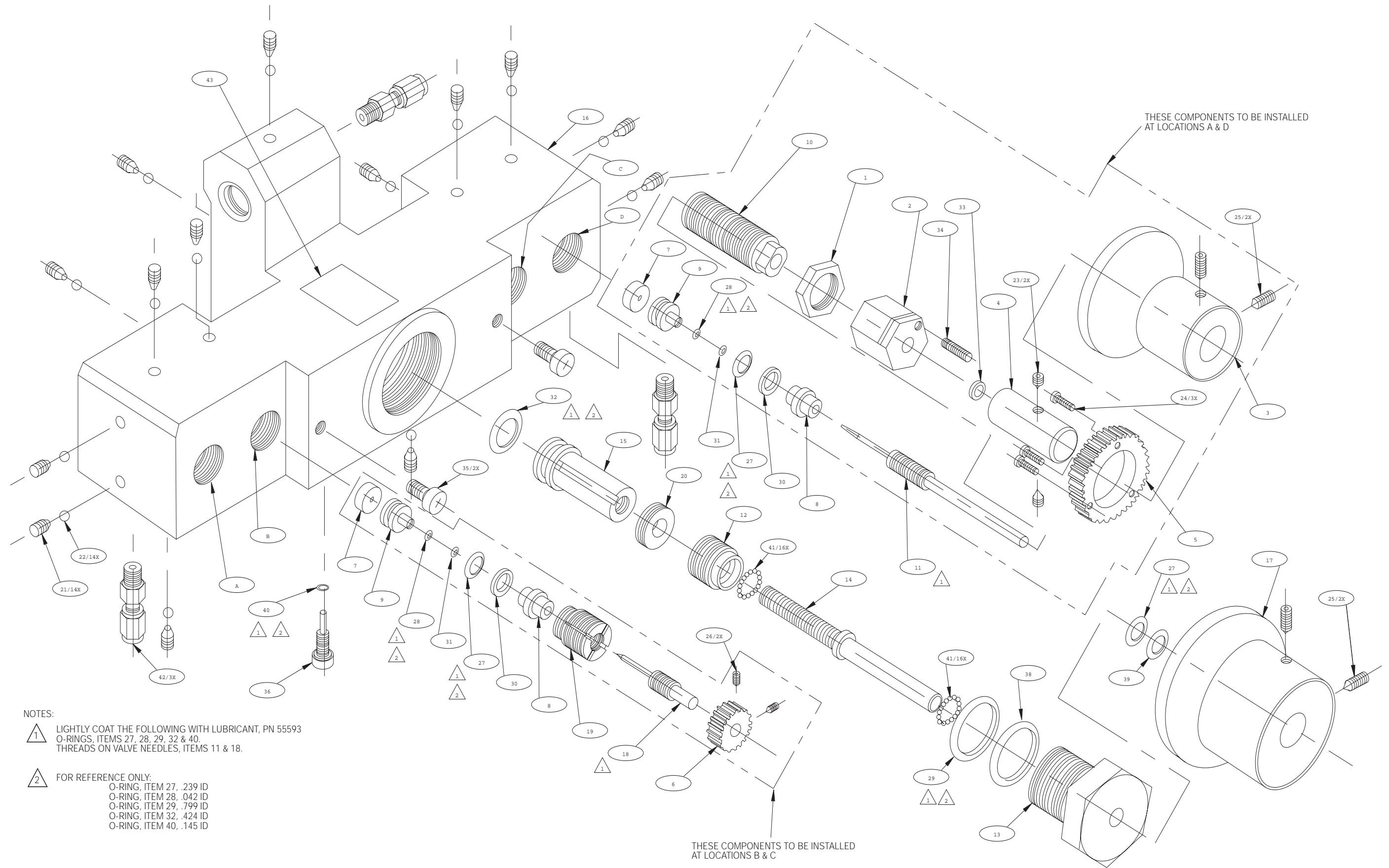

Figure 2-10. ORION-3A, Exploded View

## 2.15 MPV-10K Valve Assembly Parts List

The following table lists the component parts of the MPV-10K.

Ref Number	PN	Description	Quantity
1	54193	Valve body	1
2	54540	Housing, valve needle	1
3	59551	Valve needle	1
4	55896	Valve, seat	1
5	59045	Valve, needle seat	1
6	56059	Valve needle	1
7	55570	Washer, backing	1
8	60837	Screw, mach-pan HD	1
9	60633	Retainer, packing	1
10	59387	Valve seat, stem	1
11	57482	Nut, valve needle housing	1
12	54401	Locknut	1
13	60202	Setscrew, hex	1
14	59245	Washer, flat	1
15	58344	Knob	1
16	59322	Setscrew	2
18	55569	O-ring, Fluorocarbon (Viton) color black w/white dot	1
19	55541	O-ring, Ethylene Propylene, color black	1
20	55546	O-ring, Silicone, color rust	1
21	55549	O-ring, Neoprene, color black	1
22	55536	O-ring, Buna-N (Nitrile), color black	1
23	55554	O-ring, Buna-N (Nitrile), color black	1
24	55558	O-ring, Ethylene Propylene, color black	1
25	55562	O-ring, Silicone, color rust	1
26	55565	O-ring, Neoprene, color black	1
27	55552	O-ring, Fluorocarbon (Viton), color black w/white dot	1

*Table 2-4. MPV-10K Valve Assembly Parts List*

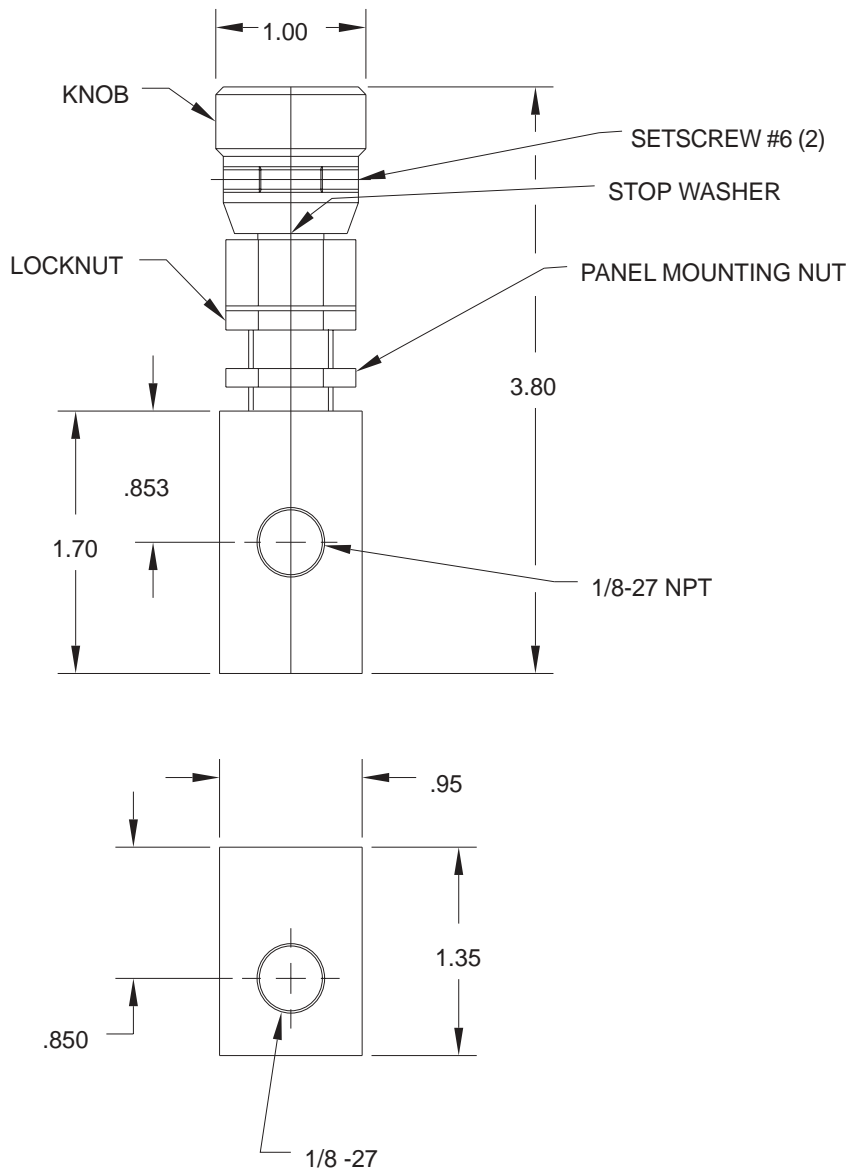

Figure 2-11. MPV-10k Valve Assembly Mounting View

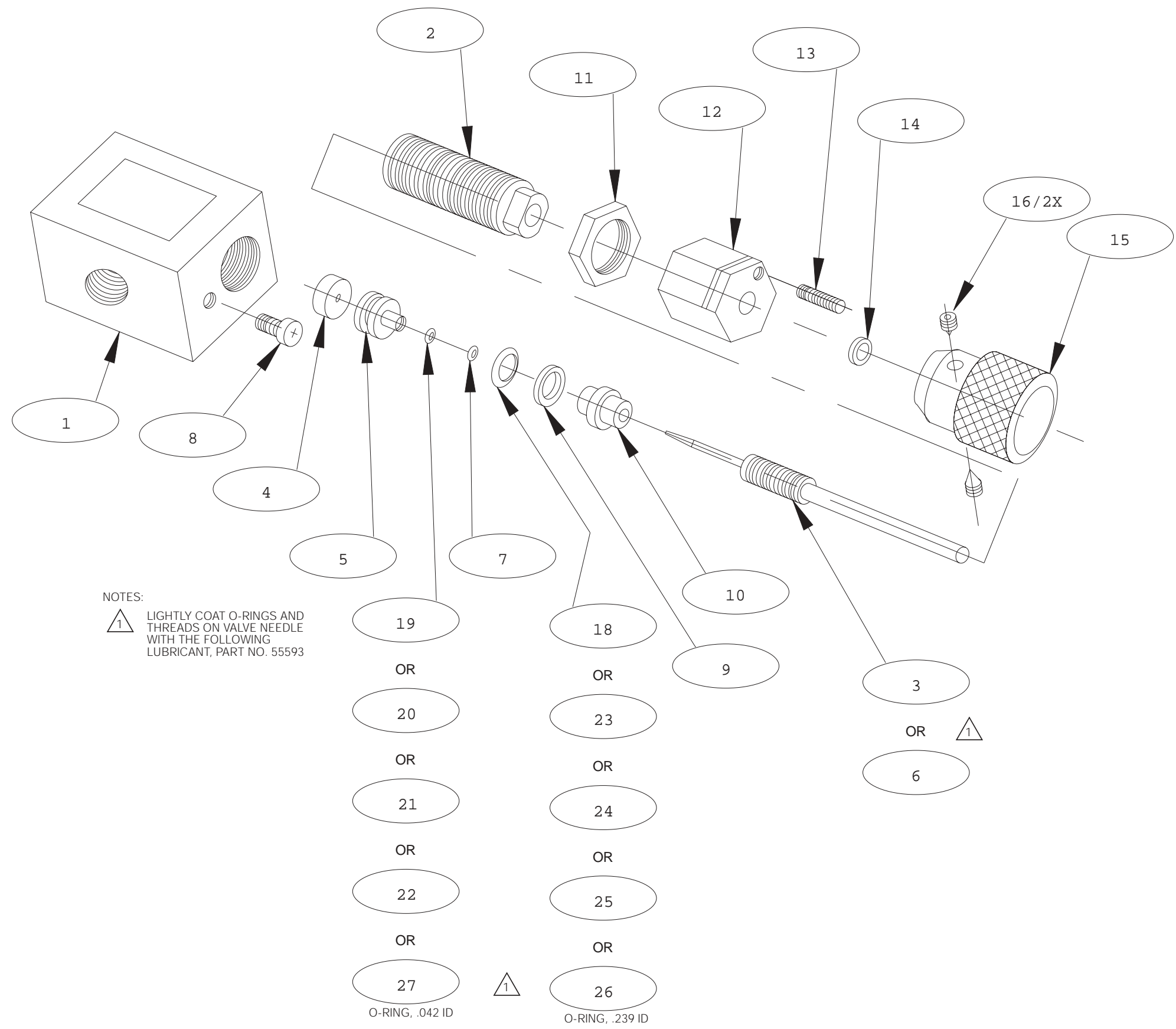

Figure 2-12. MPV-10K, Exploded View

## 3.0 Specifications

---

### 3.0.1 ORION-2C (PN 55283)

#### Pressure Specifications:

Pressure Range: 3000 PSI max and vacuum  
Operating  
Temperature: +40° to +122°F (+4.4° to +50.0° C)  
Storage Temperature: 0° to +185° F (-17.8° to +85°C)  
Type: Micro-metering with replaceable soft seat  
Material: Aluminum body, clear anodize.  
Aluminum knobs, black anodize. All other parts 300 series Stainless Steel  
Weight: 3.0 lbs  
O-ring Material: Buna-N (standard)

**Note:** Various O-ring materials may be installed in ORION-2C by special order.

### 3.0.2 ORION-2D (PN 55286)

Pressure Range: 0-300 PSI max and vacuum  
Operating  
Temperature: +40° to +122° F(+4.4° to +50.0° C)  
Storage Temperature: 0° to +185° F (-17.8° to +85° C)  
Type: Micro-metering with replaceable soft seat.  
Material: Aluminum body, clear anodize.  
Aluminum knobs, black anodize. All other parts 300 series Stainless Steel.  
Weight: 3.0 lbs  
O-ring Material: Buna-N (standard)

**Note:** Various O-ring materials may be installed in ORION-2D by special order.

### 3.0.3 ORION-3A (PN 55287)

Pressure Range: 0-10000 PSI max and vacuum  
Operating  
Temperature: +40° to +122° F(+4.4° to +50.0° C)  
Storage Temperature: 0° to +185° F (-17.8° to +85° C)  
Type: Micro-metering with replaceable soft seat.  
Material: 300 Series Stainless Steel body.  
Aluminum knobs, black anodize. All other parts 300 series Stainless Steel.  
Weight: 7.0 lbs  
O-ring Material: Fluorocarbon "Viton" (standard)

**Note:** Various O-ring materials may be installed in ORION-3A by special order. This would lower the Pressure Range see Section 2.2 on page 2.

### 3.0.4 MPV-10K

Pressure Range: 0-10000 PSI max and vacuum  
Operating  
Temperature: +40° to +122° F(+4.4° to +50.0° C)  
Storage Temperature: 0° to +185° F (-17.8° to +85° C)  
Type: Micro-metering with replaceable soft seat.  
Material: 300 Series Stainless Steel body.  
Aluminum knobs, black anodize. All other parts 300 series Stainless Steel.  
Weight: 3.0 lbs  
O-ring Material: Fluorocarbon "Viton" (standard) (PN 57168)

**Note:** Various O-ring materials may be installed in MPV-10K, but are not rated for 10,000 PSI.

Nitrile Buna-N O-ring (PN 54803)  
Ethylene-propylene O-ring (PN 54906)  
Silicone O-ring (PN 57161)  
Neoprene O-ring (PN 57122)



## Orion/MPV-10K Warranty and Return Policy

---

If possible, please save original packing material which is specifically designed for the unit. Should it be necessary to ship the unit back to the factory, a suitable shipping container *must* be used along with sufficient packing material. *Do not* put a shipping label on the unit as a "suitable shipping container." Some units have been severely damaged this way. This is a delicate, precision instrument. Any damage incurred because of poor packaging procedures will ultimately result in added service charges and longer turn-around times.



### Warning

*Vent unit to the atmosphere before shipping.*

When factory service is required, send in only the unit for repair. Retain manual, etc. at your facility. However, if there is a problem with a particular part, send in that part with the unit.

If a unit is found to be defective, it may be returned to our repair facility at the following address:

CONDEC  
3 SIMM LANE  
DOOR D, UNIT 2A  
NEWTOWN, CT 06470

ATTN: PRESSURE PRODUCTS/REPAIR LAB

Each unit's I.D. plate is stamped with a date code (week/year) prior to shipment. Our warranty is twelve (12) months from that date code and includes repair and/or replacement of the unit at our, Newtown facilities at no charge. Units subjected to abuse or damaged by external influences, are not covered under warranty.

If the unit is found to be out of warranty, an evaluation charge of not less than fifty (U.S.) dollars (\$50.00) will be charged. Please note on any attached paperwork if a repair estimate is required or if there are any other specific instructions.

Please be explicit as to the nature of the problem and/or its symptoms. Your documentation will save needless time and expense. Also, please include a return shipping address (with a street address) and a contact name with fax and telephone numbers. Contact numbers are necessary to provide a job estimate and in case further questions arise at the factory.

