

# Operating Instructions

## Indumax CLS50D/CLS50

Digital sensor with Memosens protocol or analog sensor  
For inductive measurement of conductivity in liquids

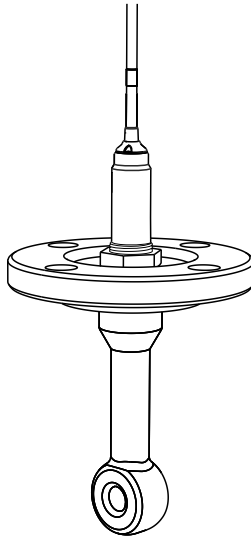

# EU Declaration of Conformity

## CLS50D-BA\*\*\*\*

**EU-Konformitätserklärung**  
**EU-Declaration of Conformity**  
**Déclaration UE de Conformité**

**Endress+Hauser**   
 People for Process Automation



**Company** **Endress+Hauser Conducta GmbH+Co. KG**  
**Dieselstraße 24, 70839 Gerlingen, Germany**  
 erklärt als Hersteller in alleiniger Verantwortung, dass das Produkt  
 declares as manufacturer under sole responsibility, that the product  
 déclare sous sa seule responsabilité en qualité de fabricant que le produit

**Product** **Indumax**  
**CLS50D-BA\*\*\*\***

**Regulations** den folgenden Europäischen Richtlinien entspricht:  
 conforms to following European Directives:  
 est conforme aux prescription des Directives Européennes suivantes :

EMC 2014/30/EU (L96/79)  
 ATEX 2014/34/EU (L96/309)

**Standards** angewandte harmonisierte Normen oder normative Dokumente:  
 applied harmonized standards or normative documents:  
 normes harmonisées ou documents normatifs appliqués :

EN 61326-1 (2013) EN 60079-0 (2012) A11:2013  
 EN 61326-2-3 (2013) EN 60079-11 (2012)  
 EN 60079-26 (2007) +Corrigendum 1

**Certification** EG-Baumusterprüfbescheinigung Nr. BVS 12 ATEX E 048 X  
 EC-Type Examination Certificate No.  
 Numéro de l'attestation d'examen CE de type

Ausgestellt von/issued by/délivré par DEKRA EXAM GmbH (0158)  
 Qualitätssicherung/Quality assurance/Système d'assurance DEKRA EXAM GmbH (0158)  
 qualité

Gerlingen, 20.04.2016  
 Endress+Hauser Conducta GmbH+Co. KG

  
 i. V. Jörg-Martin Müller  
 Technology

  
 i. V. Sven-Matthias Scheibe  
 Technology Certifications and Approvals



EC\_00368\_01.16

## CLS50-G\*\*\*

**EU-Konformitätserklärung**  
**EU-Declaration of Conformity**  
**Déclaration UE de Conformité**

**Endress+Hauser**   
 People for Process Automation

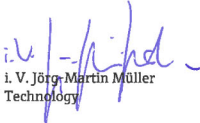

<b>Company</b>	<b>Endress+Hauser Conducta GmbH+Co. KG</b> Dieselstraße 24, 70839 Gerlingen, Germany	
	erklärt als Hersteller in alleiniger Verantwortung, dass das Produkt declares as manufacturer under sole responsibility, that the product déclare sous sa seule responsabilité en qualité de fabricant que le produit	
<b>Product</b>	<b>Indumax</b> CLS50-G***	
<b>Regulations</b>	den folgenden Europäischen Richtlinien entspricht: conforms to following European Directives: est conforme aux prescription des Directives Européennes suivantes :	
	EMC	2014/30/EU (L96/79)
	ATEX	2014/34/EU (L96/309)
<b>Standards</b>	angewandte harmonisierte Normen oder normative Dokumente: applied harmonized standards or normative documents: normes harmonisées ou documents normatifs appliqués :	
	EN 61326-1	(2013) EN 60079-0 (2012) + A11 (2013)
	EN 61326-2-3	(2013) EN 60079-11 (2012)
<b>Certification</b>	EG-Baumusterprüfbescheinigung Nr. EC-Type Examination Certificate No. Numéro de l'attestation d'examen CE de type Ausgestellt von/issued by/dé livré par	DMT 99 ATEX 075 X  DEKRA EXAM GmbH (0158)
	Qualitätssicherung/Quality assurance/Système d'assurance qualité	DEKRA EXAM GmbH (0158)
	Gerlingen, 02.08.2016 Endress+Hauser Conducta GmbH+Co. KG	
	 i. V. Jörg Martin Müller Technology	 i. V. Robert Blinder Technology Certifications and Approvals

EC\_00438\_01.16

## CLS50D-BV\*\*\*\*

**EU-Konformitätserklärung**  
**EU-Declaration of Conformity**  
**Déclaration UE de Conformité**

**Endress+Hauser**   
 People for Process Automation



**Company** **Endress+Hauser Conducta GmbH+Co. KG**  
 Dieselstraße 24, 70839 Gerlingen, Germany  
 erklärt als Hersteller in alleiniger Verantwortung, dass das Produkt  
 declares as manufacturer under sole responsibility, that the product  
 déclare sous sa seule responsabilité en qualité de fabricant que le produit

**Product** **Indumax**  
 CLS50D-BV\*\*\*\*

**Regulations** den folgenden Europäischen Richtlinien entspricht:  
 conforms to following European Directives:  
 est conforme aux prescription des Directives Européennes suivantes :

EMC 2014/30/EU (L96/79)  
 ATEX 2014/34/EU (L96/309)  
 RoHS 2011/65/EU (L174/88)

**Standards** angewandte harmonisierte Normen oder normative Dokumente:  
 applied harmonized standards or normative documents:  
 normes harmonisées ou documents normatifs appliqués :

EN 61326-1	(2013)	EN 60079-0	(2012)	A11:2013
EN 61326-2-3	(2013)	EN 60079-11	(2012)	
EN 50581	(2012)			

**Certification** EG-Baumusterprüfbescheinigung Nr. -  
 EC-Type Examination Certificate No. -  
 Numéro de l'attestation d'examen CE de type -  
 Ausgestellt von/issued by/délivré par -  
 Qualitätssicherung/Quality assurance/Système d'assurance DEKRA EXAM GmbH (0158)  
 qualité

Gerlingen, 22.07.2017  
 Endress+Hauser Conducta GmbH+Co. KG

  
 i. V. Jörg-Martin Müller  
 Technology

  
 i. V. Sven-Matthias Scheibe  
 Technology Certifications and Approvals

## CLS50-V\*\*\*

**EU-Konformitätserklärung**  
**EU-Declaration of Conformity**  
**Déclaration UE de Conformité**

**Endress+Hauser**   
 People for Process Automation



**Company** **Endress+Hauser Conducta GmbH+Co. KG**  
**Dieselstraße 24, 70839 Gerlingen, Germany**  
 erklärt als Hersteller in alleiniger Verantwortung, dass das Produkt  
 declares as manufacturer under sole responsibility, that the product  
 déclare sous sa seule responsabilité en qualité de fabricant que le produit

**Product** **Indumax**  
 CLS50-V\*\*\*

**Regulations** den folgenden Europäischen Richtlinien entspricht:  
 conforms to following European Directives:  
 est conforme aux prescription des Directives Européennes suivantes :

EMC	2014/30/EU (L96/79)
ATEX	2014/34/EU (L96/309)
RoHS	2011/65/EU (L174/88)

**Standards** angewandte harmonisierte Normen oder normative Dokumente:  
 applied harmonized standards or normative documents:  
 normes harmonisées ou documents normatifs appliqués :

EN 61326-1	(2013)	EN 60079-0	(2012)
EN 61326-2-3	(2013)	EN 60079-11	(2012) + A11 (2013)
EN 50581	(2012)		

**Marking**  II 3G Ex ic IIC T4/T6 Gc

Gerlingen, 31.05.2017  
 Endress+Hauser Conducta GmbH+Co. KG

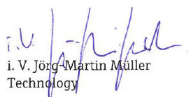
  
 i. V. Jörg-Martin Müller  
 Technology

  
 i. V. Robert Binder  
 Technology Certifications and Approvals



EC\_00440\_02.16

# Table of contents







<b>1</b>	<b>About this document</b> .....	<b>7</b>	10.2	Performance characteristics	36
1.1	Warnings	7	10.3	Environment	36
1.2	Symbols used	7	10.4	Process	37
1.3	Symbols on the device	8	10.5	Mechanical construction	39
<b>2</b>	<b>Basic safety instructions</b> .....	<b>9</b>	<b>Index</b> .....		<b>42</b>
2.1	Requirements for personnel	9			
2.2	Designated use	9			
2.3	Workplace safety	9			
2.4	Operational safety	10			
2.5	Product safety	10			
<b>3</b>	<b>Incoming acceptance and product identification</b> .....	<b>14</b>			
3.1	Incoming acceptance	14			
3.2	Product identification	14			
3.3	Scope of delivery	17			
3.4	Certificates and approvals	18			
<b>4</b>	<b>Installation</b> .....	<b>19</b>			
4.1	Installation conditions	19			
4.2	Mounting the sensor	21			
4.3	Post-installation check	24			
<b>5</b>	<b>Electrical connection</b> .....	<b>24</b>			
5.1	Connection conditions	25			
5.2	Connecting the sensor	29			
5.3	Ensuring the degree of protection	30			
5.4	Post-connection check	30			
<b>6</b>	<b>Commissioning</b> .....	<b>31</b>			
<b>7</b>	<b>Maintenance</b> .....	<b>31</b>			
<b>8</b>	<b>Repair</b> .....	<b>32</b>			
8.1	Spare parts	32			
8.2	Return	33			
8.3	Disposal	33			
<b>9</b>	<b>Accessories</b> .....	<b>33</b>			
9.1	Measuring cable	34			
9.2	Assemblies	34			
9.3	Calibration solutions	35			
<b>10</b>	<b>Technical data</b> .....	<b>35</b>			
10.1	Input	35			

# 1 About this document

## 1.1 Warnings

Structure of information	Meaning
<p> <b>DANGER</b></p> <p><b>Causes (/consequences)</b> If necessary, Consequences of non-compliance (if applicable)</p> <ul style="list-style-type: none"> <li>▶ Corrective action</li> </ul>	<p>This symbol alerts you to a dangerous situation. Failure to avoid the dangerous situation <b>will</b> result in a fatal or serious injury.</p>
<p> <b>WARNING</b></p> <p><b>Causes (/consequences)</b> If necessary, Consequences of non-compliance (if applicable)</p> <ul style="list-style-type: none"> <li>▶ Corrective action</li> </ul>	<p>This symbol alerts you to a dangerous situation. Failure to avoid the dangerous situation <b>can</b> result in a fatal or serious injury.</p>
<p> <b>CAUTION</b></p> <p><b>Causes (/consequences)</b> If necessary, Consequences of non-compliance (if applicable)</p> <ul style="list-style-type: none"> <li>▶ Corrective action</li> </ul>	<p>This symbol alerts you to a dangerous situation. Failure to avoid this situation can result in minor or more serious injuries.</p>
<p><b>NOTICE</b></p> <p><b>Cause/situation</b> If necessary, Consequences of non-compliance (if applicable)</p> <ul style="list-style-type: none"> <li>▶ Action/note</li> </ul>	<p>This symbol alerts you to situations which may result in damage to property.</p>

## 1.2 Symbols used

Symbol	Meaning
	Additional information, tips
	Permitted or recommended
	Not permitted or not recommended
	Reference to device documentation
	Reference to page
	Reference to graphic
	Result of a step

## 1.3 Symbols on the device

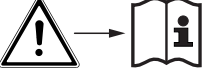
Symbol	Meaning
	Reference to device documentation



## 2 Basic safety instructions

### 2.1 Requirements for personnel

- Installation, commissioning, operation and maintenance of the measuring system may be carried out only by specially trained technical personnel.
- The technical personnel must be authorized by the plant operator to carry out the specified activities.
- The electrical connection may be performed only by an electrical technician.
- The technical personnel must have read and understood these Operating Instructions and must follow the instructions contained therein.
- Faults at the measuring point may only be rectified by authorized and specially trained personnel.



Repairs not described in the Operating Instructions provided must be carried out only directly at the manufacturer's site or by the service organization.

### 2.2 Designated use

Indumax CLS50D or CLS50 sensor is particularly suitable for use in the chemical and process technology sectors. The six-decade measuring range and the excellent chemical resistance properties of the materials in contact with the medium (PFA or PEEK) make it possible to use this sensor in a wide range of applications, such as:

- Concentration measurement of acids and bases
- Quality monitoring of chemical products in tanks and pipes
- Phase separation of product/product mixtures

The digital sensor CLS50D is used in conjunction with the Liquiline CM44x/R or Liquiline M CM42, while the analog sensor CLS50 is used with the Liquiline M CM42 or Liquisys CLM223/253.

Use of the device for any purpose other than that described, poses a threat to the safety of people and of the entire measuring system and is therefore not permitted.

The manufacturer is not liable for damage caused by improper or non-designated use.

### 2.3 Workplace safety

As the user, you are responsible for complying with the following safety conditions:

- Installation guidelines
- Local standards and regulations
- Regulations for explosion protection

#### **Electromagnetic compatibility**

- The product has been tested for electromagnetic compatibility in accordance with the applicable international standards for industrial applications.
- The electromagnetic compatibility indicated applies only to a product that has been connected in accordance with these Operating Instructions.

## 2.4 Operational safety

### Before commissioning the entire measuring point:

1. Verify that all connections are correct.
2. Ensure that electrical cables and hose connections are undamaged.
3. Do not operate damaged products, and protect them against unintentional operation.
4. Label damaged products as defective.

### During operation:

- ▶ If faults cannot be rectified:  
products must be taken out of service and protected against unintentional operation.

## 2.5 Product safety

### 2.5.1 State-of-the-art technology

The product is designed to meet state-of-the-art safety requirements, has been tested, and left the factory in a condition in which it is safe to operate. The relevant regulations and international standards have been observed.

### 2.5.2 Electrical equipment in hazardous areas

Sensors with ATEX approval (CLS50-G\*\*\* and CLS50D-BA\*\*\*\* for Zone 0, CLS50-V\*\*\* and CLS50D-BV\*\*\*\* for Zone 2) have been developed and manufactured in compliance with applicable European standards and guidelines and are suitable for use in hazardous areas. The Declaration of Conformity confirms compliance with the harmonized European standards for using the sensors in hazardous areas.

**CLS50D-BA\*\*\*\*, CLS50D-IA\*\*\*\*, CLS50D-GB\*\*\*\*, CLS50D-NA\*\*\*\*, CLS50D-H\*\*\*\*, CLS50-G\*\*\* and CLS50-K\*\*\***

- The sensors may be operated in an environment specified as Ex Zone 0 (1G).
- The sensors may only be used in liquid media with a conductivity  $>10$  nS/cm.
- If the connecting cable runs through Ex Zone 0 (1G), it must be protected against electrostatic charge.

**CLS50D-BA\*\*\*\*, CLS50D-IA\*\*\*\*, CLS50D-NA\*\*\*\* and CLS50D-GB\*\*\*\***

- The sensor is a digital sensor with the Memosens protocol and its connection values are those specified below.
- The sensor may also be connected to the intrinsically safe Memosens connection of the FSDG1 module of the Liquiline transmitter, types CM42-LE, CM42-LF, CM42-LI, EC type-examination certificate EX5 05 03 30266 012 (ATEX or IECEx) or CM42-LK (EAC Ex).
- The maximum permitted length of the measuring cable is 100 m (330 ft) here.

*Connection values of the CLS50D-BA\*\*\*\*, CLS50D-IA\*\*\*\* and CLS50D-GB\*\*\*\* sensor*

$U_i$	5.1 V
$I_i$	130 mA
$P_i$	166 mW

C <sub>i</sub>	18 µF
L <sub>i</sub>	72 µH

*Temperature classes of CLS50D-BA\*\*\*\*, CLS50D-IA\*\*\*\* and CLS50D-GB\*\*\*\**

Temperature class	Sensor	Ambient temperature range T <sub>a</sub>	Medium temperature range T <sub>med</sub>
T4	CLS50D-BA/IA/ GB*D** CLS50D-BA/IA/ GB*C** CLS50D-BA/IA/ GB*B**	-20 to +60 °C -20 to +60 °C -20 to +60 °C	-20 to +110 °C -20 to +120 °C -20 to +120 °C
T6	CLS50D-BA/IA/ GB*D** CLS50D-BA/IA/ GB*C** CLS50D-BA/IA/ GB*B**	-20 to +60 °C -20 to +60 °C -20 to +60 °C	-20 to +70 °C -20 to +70 °C -20 to +70 °C

**CLS50-G\*\*\***

- The sensor may only be connected to the following transmitters:
  - Liquiline types CM42-IG, CM42-IE, CM42-IF, EC type-examination certificate TÜV 13 ATEX 7459 X
  - Mycom type CLM153-Z with transmitter module type FCL1, EC type-examination certificate DMT 99 ATEX E 076
  - Mycom type CLM153-G, EC type-examination certificate DMT 01 ATEX E 174
- The maximum permitted length of the measuring cable is 55 m (180 ft) here.

*Temperature classes of CLS50-G\*\*\**

Temperature class	Sensor	Ambient temperature range T <sub>a</sub>	Medium temperature range T <sub>med</sub>
T4	CLS50-G***	-20 to +125 °C	-20 to +125 °C
T6	CLS50-G***	-20 to +75 °C	-20 to +75 °C

**CLS50D-BV\*\*\*\* and CLS50-V\*\*\***

- The sensor may be operated in an environment specified as Ex Zone 2 (3G).
- The sensor may only be connected to the following transmitter:  
Liquiline type CM42-LV (CLS50D) or CM42-IV (CLS50), EU Declaration of Conformity EC\_00143\_01.16
- Only CLS50-V\*\*\*: The maximum permitted length of the measuring cable is 55 m (180 ft) here.

*Temperature classes of CLS50D-BV\*\*\*\**

Temperature class	Sensor	Ambient temperature range T <sub>a</sub>	Medium temperature range T <sub>med</sub>
T4	CLS50D-BV*D**	-20 to +60 °C	-20 to +110 °C
	CLS50D-BV*C**	-20 to +60 °C	-20 to +120 °C
	CLS50D-BV*B**	-20 to +60 °C	-20 to +120 °C
T6	CLS50D-BV****	-20 to +60 °C	-20 to +70 °C

*Temperature classes of CLS50-V\*\*\**

Temperature class	Sensor	Ambient temperature range T <sub>a</sub>	Medium temperature range T <sub>med</sub>
T4	CLS50-V***	-20 to +125 °C	-20 to +125 °C
T6	CLS50-V***	-20 to +75 °C	-20 to +75 °C

**CLS50-K\*\*\***

- The sensor may only be connected to the following transmitter:  
Liquiline type CM42-IK
- The maximum permitted length of the measuring cable is 55 m (180 ft) here.

*Temperature classes of CLS50-K\*\*\**

Temperature class	Sensor	Ambient temperature range T <sub>a</sub>	Medium temperature range T <sub>med</sub>
T4	CLS50-K***	-20 to +125 °C	-20 to +125 °C
T6	CLS50-K***	-20 to +75 °C	-20 to +75 °C

**Sensors with FM and CSA approval (CLS50D-FB\*\*\*\*, CLS50D-C2\*\*\*\*, CLS50-O\*\*\*, CLS50-S\*\*\*\*)**

Observe the documentation and the control drawings of the transmitter.

**Sensors with NEPSI approval (CLS50D-NA\*\*\*\* and CLS50-H\*\*\* for Zone 0, CLS50-V\*\*\* for Zone 2)**

Pay attention to the information on the NEPSI certificates. You can download these certificates from the product page: [www.endress.com/cls50d](http://www.endress.com/cls50d) or [www.endress.com/cls50](http://www.endress.com/cls50).

*Temperature classes of CLS50D-NA\*\*\*\**

Temperature class	Sensor	Ambient temperature range T <sub>a</sub>	Medium temperature range T <sub>med</sub>
T4	CLS50D-NA*D**	-20 to +60 °C	-20 to +110 °C
	CLS50D-NA*C**	-20 to +60 °C	-20 to +120 °C
	CLS50D-NA*B**	-20 to +60 °C	-20 to +120 °C
T6	CLS50D-NA*D**	-20 to +60 °C	-20 to +70 °C
	CLS50D-NA*C**	-20 to +60 °C	-20 to +70 °C
	CLS50D-NA*B**	-20 to +60 °C	-20 to +70 °C

*Temperature classes of CLS50-H\*\*\**

Temperature class	Sensor	Ambient temperature range T <sub>a</sub>	Medium temperature range T <sub>med</sub>
T4	CLS50-H***	-20 to +125 °C	-20 to +125 °C
T6	CLS50-H***	-20 to +75 °C	-20 to +75 °C

**Sensors with TIIS approval (CLS50D-TA\*\*\*\*, CLS50-T\*\*\*\*)**

Sensors with TIIS approval may only be used in a Zone 1 (2G) environment.

**The following also applies for all the sensors listed**

- Compliance with the specified ambient and medium temperature ranges is a prerequisite for safe use.
- The sensor must be connected and operated in accordance with the Operating Instructions of the sensor and of the transmitter to be connected. All sensor operating data must be observed.
- Avoid electrostatic charge. Metal process connections must be electrostatically connected ( $R \leq 1 \text{ M}\Omega$ ).
- Non-metal process connections must be protected against electrostatic charge.
- In order to avoid electrostatic charge clean the sensor with a damp cloth only.
- Full compliance with regulations for electrical systems in hazardous locations (EN60079-14) is mandatory when using the devices and sensors.
- Ensure correct installation to maintain the housing protection type. (Use original seal. Fit cable entry properly. Tighten nut).
- The degree of protection only applies when the flange is mounted.

**CLS50 only**

In the CLS50 sensor, the internal sensor circuits are connected with the shielded wire of the supply cable. When installing the CM42 or CLM153 transmitter, the shielding of the sensor cable must be connected to functional ground as prescribed. As a result, the intrinsically safe sensor circuits of CLS50 are also connected to ground. Therefore, the power supply of the transmitter must be galvanically isolated and connected to ground. The CM42 and CLM153 transmitters already have secure internal galvanic isolation and therefore safely separate the sensor circuit from the other circuits.

### 3 Incoming acceptance and product identification

#### 3.1 Incoming acceptance

1. Verify that the packaging is undamaged.
  - ↳ Notify the supplier of any damage to the packaging.  
Keep the damaged packaging until the issue has been resolved.
2. Verify that the contents are undamaged.
  - ↳ Notify the supplier of any damage to the delivery contents.  
Keep the damaged goods until the issue has been resolved.
3. Check that the delivery is complete and nothing is missing.
  - ↳ Compare the shipping documents with your order.
4. Pack the product for storage and transportation in such a way that it is protected against impact and moisture.
  - ↳ The original packaging offers the best protection.  
Make sure to comply with the permitted ambient conditions.

If you have any questions, please contact your supplier or your local Sales Center.

#### 3.2 Product identification

##### 3.2.1 Type code for versions with explosion protection

Name	Type	Version								
Indumax		-	BA	x	x	x	x	+	x	x
			For use in hazardous areas, ATEX II 1G Ex ia IIC T4/T6 Ga	Process connections, materials, cable connection, calibration, service No Ex relevance						

Name	Type	Version								
Indumax	CLS50D	-	IA	x	x	x	x	+	x	x
			For use in hazardous areas, IECEx Ex ia IIC T4/T6 Ga	Process connections, materials, cable connection, calibration, service No Ex relevance						

Name	Type	Version								
Indumax	CLS50D	-	BV	x	x	x	x	+	x	x
			For use in hazardous areas, ATEX II 3G Ex ic IIC T4/T6 Gc	Process connections, materials, cable connection, calibration, service No Ex relevance						

Name	Type	Version								
Indumax	CLS50D	- NA	x	x	x	x	+	x	x	
		For use in hazardous areas, NEPSI Ex ia IIC T4/T6 Ga	Process connections, materials, cable connection, calibration, service No Ex relevance							

Name	Type	Version								
Indumax	CLS50D	- C2	x	x	x	x	+	x	x	
		For use in hazardous areas, CSA IS NI C.I Div.1&2, Gr. A-D	Process connections, materials, cable connection, calibration, service No Ex relevance							

Name	Type	Version								
Indumax	CLS50D	- FB	x	x	x	x	+	x	x	
		For use in hazardous areas, FM IS NI C.I Div.1&2, Gr. A-D	Process connections, materials, cable connection, calibration, service No Ex relevance							

Name	Type	Version								
Indumax	CLS50D	- GB	x	B/C /D	x	x	+	x	x	
		For use in hazardous areas, EAC Ex, OEx ia IIC T6/T4 Ga X	Process connections, materials, cable connection, calibration, service No Ex relevance							

Name	Type	Version								
Indumax	CLS50D	- TA	x	x	x	x	+	x	x	
		For use in hazardous areas, TIIS Ex ib IIC T4 Gb	Process connections, materials, cable connection, calibration, service No Ex relevance							

Name	Type	Version								
Indumax	CLS50	- G	x	x	x					
		For use in hazardous areas, ATEX II 1G Ex ia IIC T4/T6 Ga	Process connections, materials, cable connection, calibration, service No Ex relevance							

Name	Type	Version				
Indumax	CLS50	- V	x	x	x	
		For use in hazardous areas, ATEX II 3G Ex ic IIC T4/T6 Gc / NEPSI Ex ic IIC T4/T6 Gc	Process connections, materials, cable connection, calibration, service No Ex relevance			

Name	Type	Version				
Indumax	CLS50	- H	x	x	x	
		For use in hazardous areas, NEPSI Ex ia IIC T4/T6 Ga	Process connections, materials, cable connection, calibration, service No Ex relevance			

Name	Type	Version				
Indumax	CLS50	- O	x	x	x	
		For use in hazardous areas, FM IS NI Cl.I Div.1&2, Gr. A-D	Process connections, materials, cable connection, calibration, service No Ex relevance			

Name	Type	Version				
Indumax	CLS50	- S	x	x	x	
		For use in hazardous areas, CSA IS NI Cl.I Div.1&2, Gr. A-D	Process connections, materials, cable connection, calibration, service No Ex relevance			

Name	Type	Version				
Indumax	CLS50	- T	x	x	x	
		For use in hazardous areas, TIIS Ex ib IIC T4 Gb	Process connections, materials, cable connection, calibration, service No Ex relevance			

Name	Type	Version				
Indumax	CLS50	- K	x	x	1/2 /3/ 4	
		For use in hazardous areas, EAC Ex, 0Ex ia IIC T6/T4 Ga X	Process connections, materials, cable connection, calibration, service No Ex relevance			



### 3.2.2 Nameplate

The nameplate provides you with the following information on your device:

- Manufacturer identification
  - Order code
  - Serial number
  - Ambient and process conditions
  - Safety information and warnings
  - Cell constant (nominal value)
  - Degree of protection
  - Ex labeling on hazardous area versions
- ▶ Compare the information on the nameplate with the order.

### 3.2.3 Product identification

#### Product page

[www.endress.com/cls50d](http://www.endress.com/cls50d)

[www.endress.com/cls50](http://www.endress.com/cls50)

#### Interpreting the order code

The order code and serial number of your product can be found in the following locations:

- On the nameplate
- In the delivery papers

#### Obtaining information on the product

1. Go to [www.endress.com](http://www.endress.com).
2. Call up the site search (magnifying glass).
3. Enter a valid serial number.
4. Search.
  - ↳ The product structure is displayed in a popup window.
5. Click on the product image in the popup window.
  - ↳ A new window (**Device Viewer**) opens. All of the information relating to your device is displayed in this window as well as the product documentation.

#### Manufacturer's address

Endress+Hauser Conducta GmbH+Co. KG  
Dieselstraße 24  
D-70839 Gerlingen

## 3.3 Scope of delivery

The scope of delivery includes:

- Sensor in the version ordered
- Operating Instructions

- ▶ If you have any queries:  
Please contact your supplier or local sales center.

## 3.4 Certificates and approvals

### 3.4.1 CE mark

#### Declaration of Conformity

The product meets the requirements of the harmonized European standards. As such, it complies with the legal specifications of the EU directives. The manufacturer confirms successful testing of the product by affixing to it the CE mark.

### 3.4.2 Ex approvals

#### CLS50D-BA\*\*\*\* and CLS50-G\*\*\*

ATEX II 1G Ex ia IIC T4/T6 Ga

#### CLS50D-BV\*\*\*\*

ATEX II 3G Ex ic IIC T4/T6 Gc

#### CLS50D-IA\*\*\*\*

IECEX Ex ia IIC T4/T6 Ga

#### CLS50-V\*\*\*

ATEX II 3G Ex ic IIC T4/T6 Gc + NEPSI Ex ic IIC T4/T6 Gc

#### CLS50D-NA\*\*\*\* and CLS50-H\*\*\*

NEPSI Ex ia IIC T4/T6 Ga

#### CLS50D-FB\*\*\*\* and CLS50-O\*\*\*

FM IS NI Cl.I Div.1&2,G. A-D

#### CLS50D-C2\*\*\*\* and CLS50-S\*\*\*

CSA IS NI Cl.I Div.1&2,Gr. A-D

#### CLS50D-TA\*\*\*\* and CLS50-T\*\*\*

TIIS Ex ib IIC T4 Gb

#### CLS50D-GB\*\*\*\* and CLS50-K\*\*\*

- EAC Ex, 0Ex ia IIC T6/T4 Ga X
- Zone 0
- Certificate number: TC RU C-DE.AA87.B.00088 and TC RU C-DE.ГБ05.B.00172 (only CLS50-K\*\*\*\*)
- The product has been certified in accordance with Directive TR CU 012/2011 which applies in the European Economic Area (EEA). The EAC conformity mark has been affixed to the product.

### 3.4.3 Certification body (only CLS50D-GB and CLS50-K)

ООО "НАИЮ ЦСВЭ"

Russian Federation

### 3.4.4 Marine approvals

A selection of sensors have type approval for marine applications, issued by the following classification societies: ABS (American Bureau of Shipping), BV (Bureau Veritas), DNV-GL (Det Norske Veritas-Germanische Lloyd) and LR (Lloyd's Register). Details of the order codes of the approved sensors, and the installation and ambient conditions, are provided in the relevant certificates for marine applications on the product page on the Internet.

## 4 Installation

### 4.1 Installation conditions

#### 4.1.1 Installation position

- ▶ When installing, align the sensor in such a way that the medium flows through the flow opening of the sensor in the direction of medium flow.
  - ↳ The sensor head must be completely immersed in the medium.

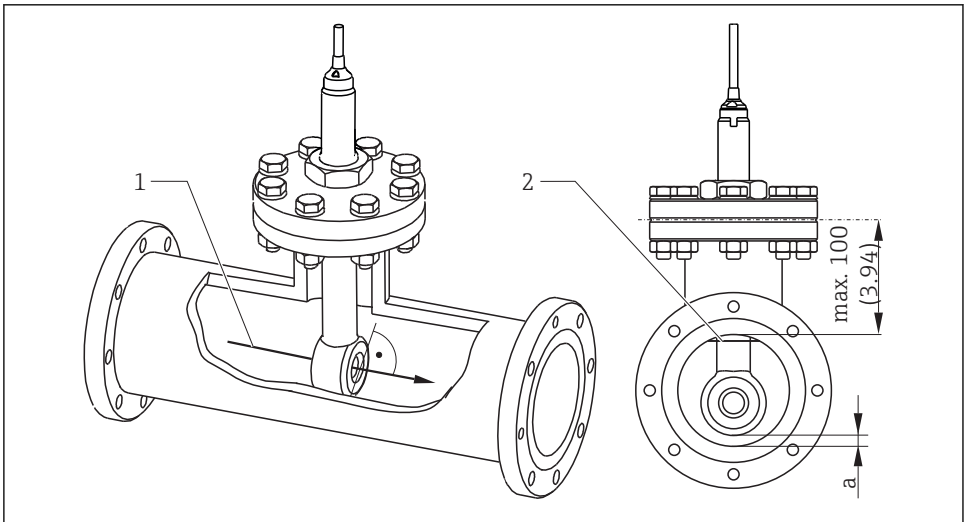

A0036463

1 Sensor orientation, dimensions in mm (in)

- 1 Direction of medium flow
- 2 Minimum water level in the pipe
- a Distance from pipe wall

#### 4.1.2 Installation factor

In confined installation conditions, the conductivity measurement is affected by the pipe walls. The installation factor compensates for this effect. The transmitter corrects the cell constant

by multiplying by the installation factor. The value of the installation factor depends on the diameter and the conductivity of the pipe nozzle as well as the sensor's distance to the wall. The installation factor  $f$  can be disregarded ( $f = 1.00$ ) if the distance to the wall is sufficient ( $a > 15 \text{ mm}$  (0.59"), from DN 80). If the distance to the wall is smaller, the installation factor increases for electrically insulating pipes ( $f > 1$ ) and decreases for electrically conductive pipes ( $f < 1$ ). It can be measured using calibration solutions, or a close approximation determined from the following diagram.

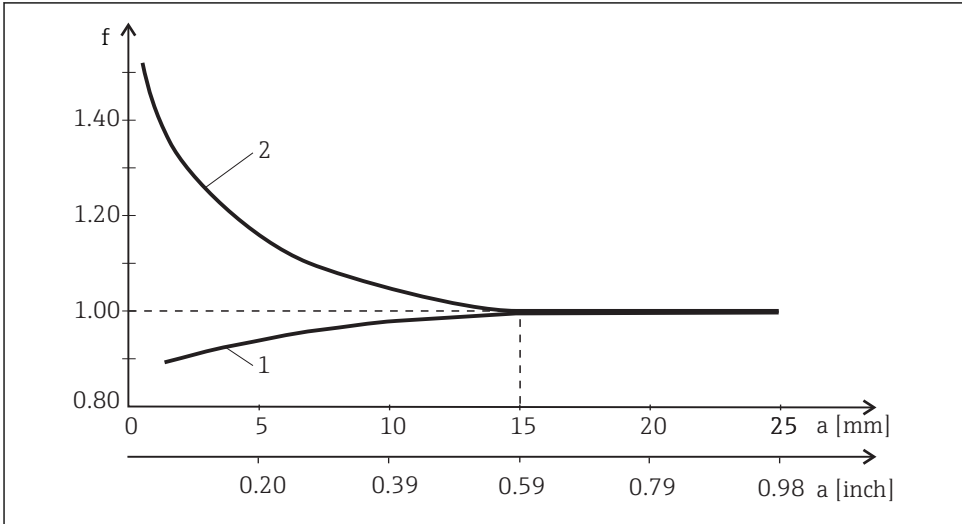

A0034874

## 2 Relationship between installation factor $f$ and wall distance

- 1 Electrically conductive pipe wall
- 2 Electrically insulating pipe wall

### 4.1.3 Air set

#### CLS50D

The digital sensor has already been adjusted at the factory. Onsite compensation is not required.

#### CLS50

To compensate residual coupling in the cable and between the two sensor coils, zero adjustment in air ("air set") must be performed before installing the sensor. Follow the instructions provided in the Operating Instructions of the transmitter used.

## 4.2 Mounting the sensor

### 4.2.1 Installation with flange

The sensor is suitable for installation in T-pieces  $\geq$  DN 80, with the outgoing diameter reduced to  $\geq$  DN 50.

#### **⚠ WARNING**

#### **Leakage**

Risk of injury if medium escapes!

- ▶ Tighten sensor nut using a torque of 20 Nm.
- ▶ To avoid leakages, regularly check the tightness of the nut.

#### **Flange, not in contact with medium**

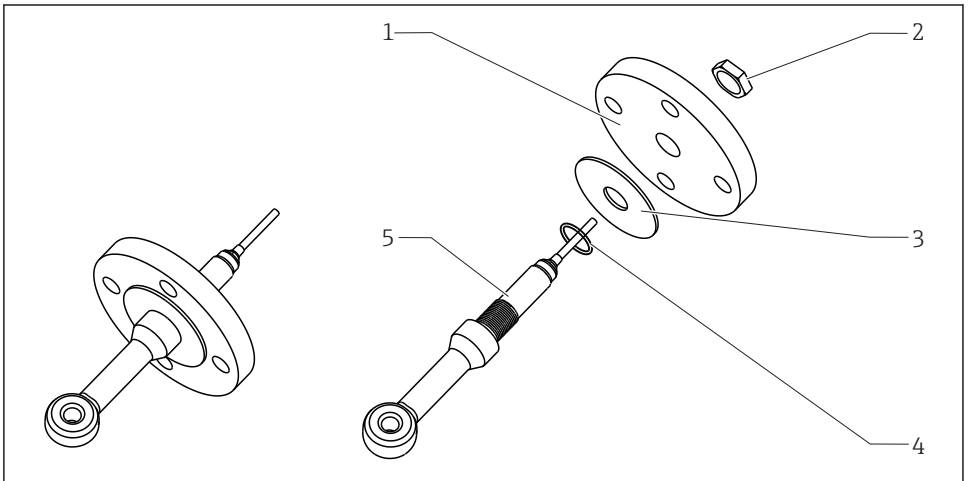

A0024949

**3** Fixed flange, not in contact with medium (for order option: "Process connection" = 5, 6, 7)

- 1 Flange (stainless steel)
- 2 Nut
- 3 Sealing disk (GYLON)
- 4 O-ring
- 5 Sensor

## Flange, in contact with medium

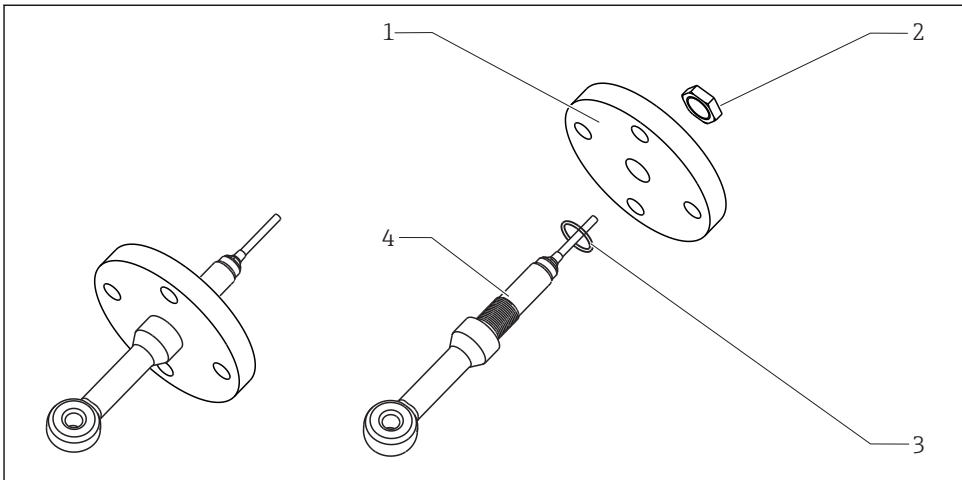

A0024953

■ 4 Fixed flange, in contact with medium (for order option: "Process connection" = 3, 4)

- 1 Flange (stainless steel)
- 2 Nut
- 3 O-ring
- 4 Sensor

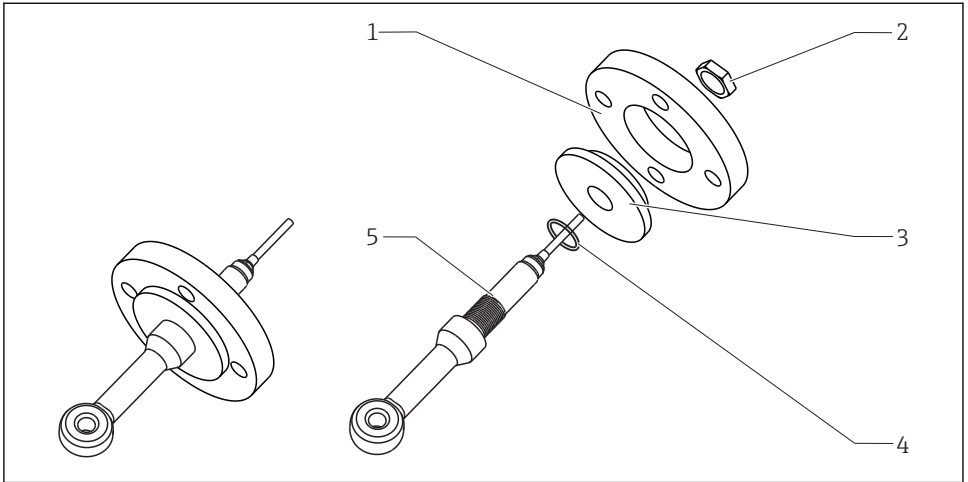
**Lap joint flange, not in contact with medium**

A0024954

☒ 5 *Lap joint flange, not in contact with medium (for order option: "Process connection" = A, B, C)*

- 1 *Lap joint flange (PP-GF)*
- 2 *Nut (stainless steel)*
- 3 *Flange (PVDF)*
- 4 *O-ring*
- 5 *Sensor*

### 4.2.2 Installation in assembly

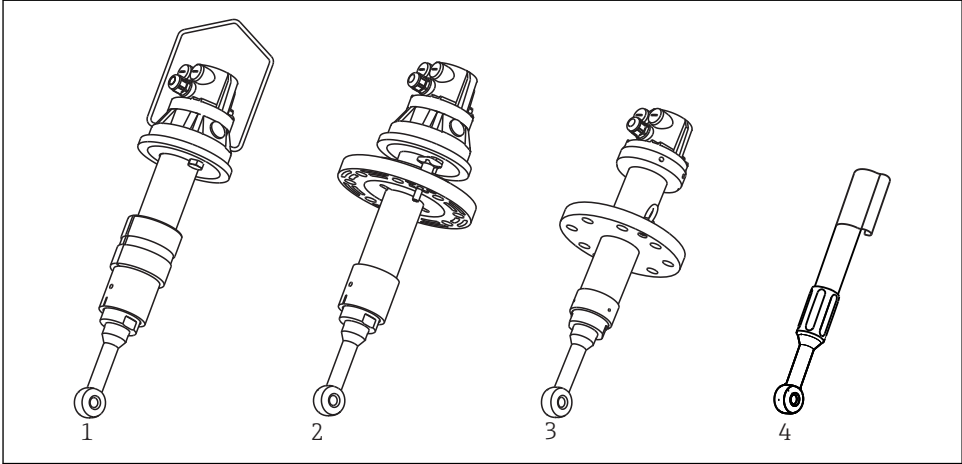

A0024960

#### 6 Installation of sensor with assembly

- 1 CLA111 with suspension bracket
- 2 CLA111 with flange connection
- 3 CLA140 with flange connection
- 4 CYA112

## 4.3 Post-installation check

Put the sensor into operation only if you can answer yes to the following questions:

1. Are the sensor and cable undamaged?
2. Is the orientation correct (arrow on threaded sleeve=flow direction=installation direction)?
3. Has the sensor been installed in the process connection, and does not suspend freely from the cable?

# 5 Electrical connection

## ⚠ WARNING

### Device is live!

Incorrect connection may result in injury or death!

- ▶ The electrical connection may be performed only by an electrical technician.
- ▶ The electrical technician must have read and understood these Operating Instructions and must follow the instructions contained therein.
- ▶ **Prior** to commencing connection work, ensure that no voltage is present on any cable.



## 5.1 Connection conditions

### 5.1.1 Connection diagram: sensors for Zone 0 (ATEX/EAC Ex)

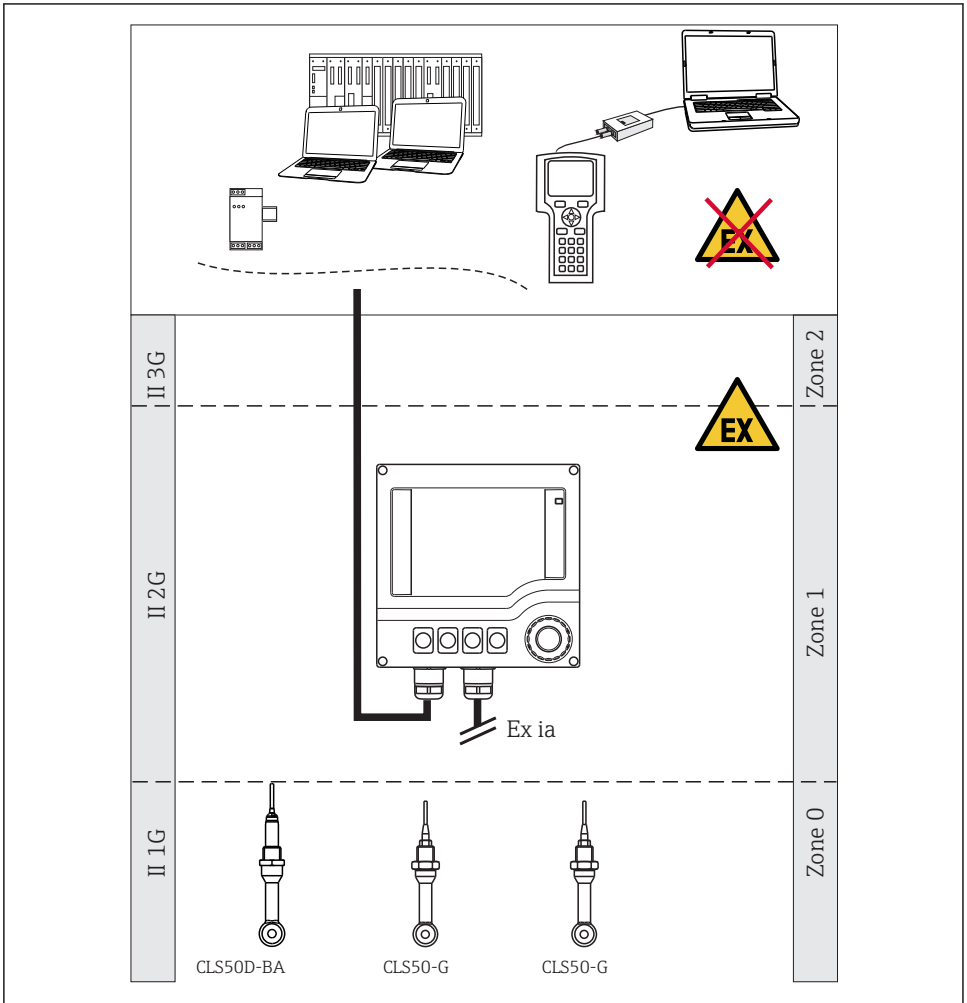

A0013258

### 5.1.2 Connection diagram: sensors for Zone 0 (IECEx)

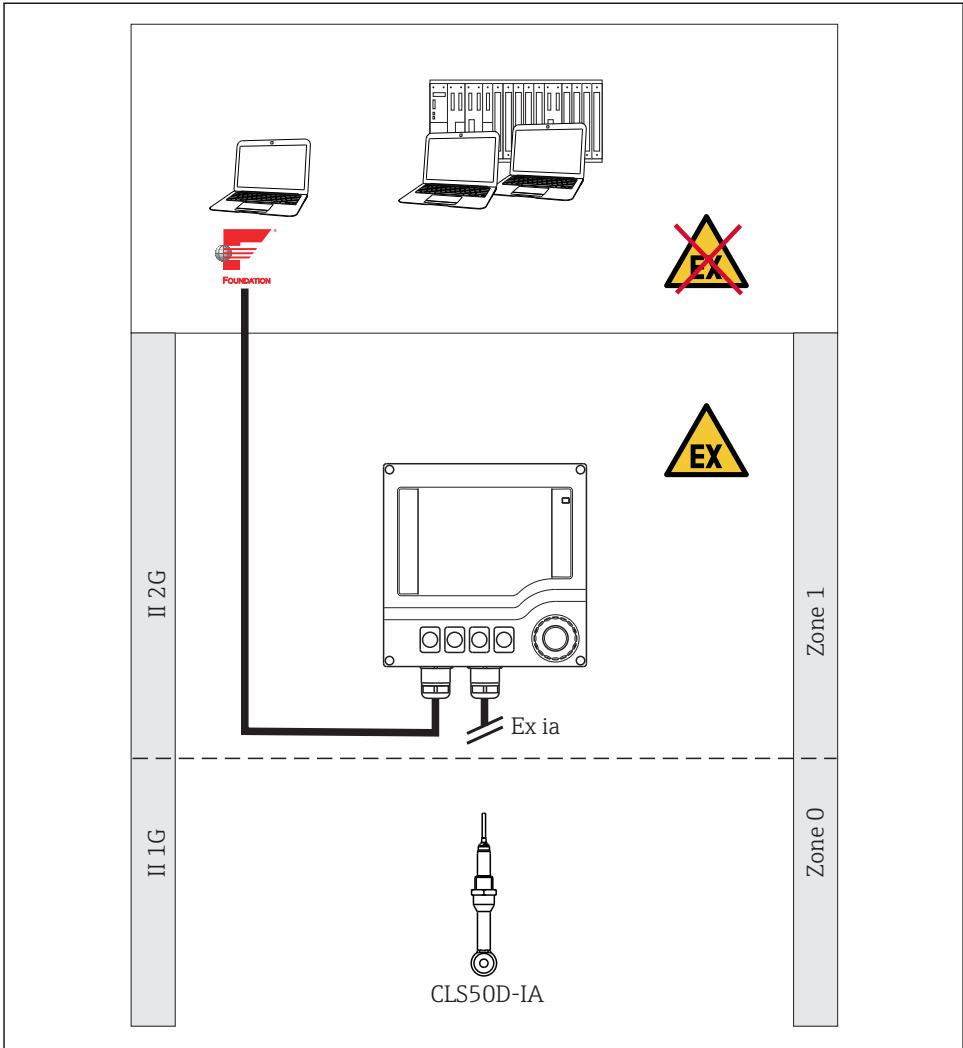

A0025482

### 5.1.3 Connection diagram: sensors for Zone 0 (NEPSI)

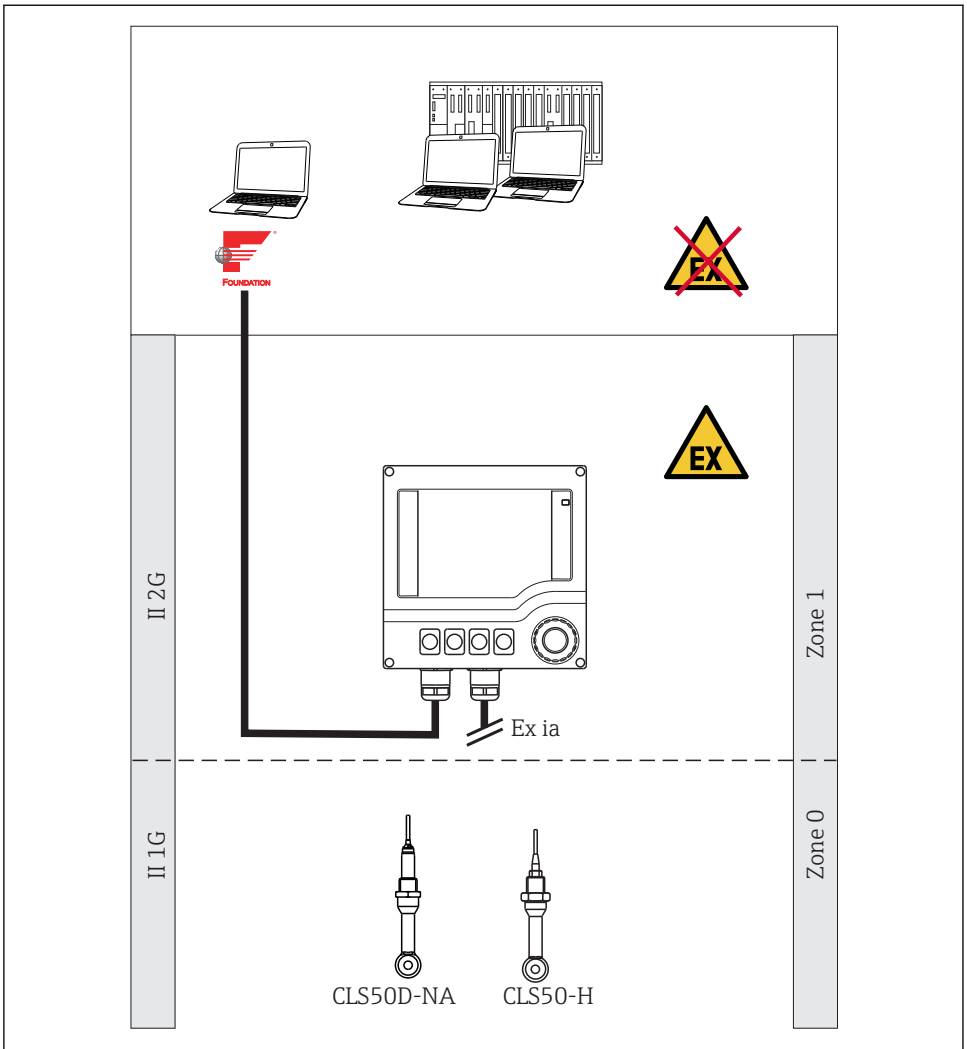

A0025481

### 5.1.4 Connection diagram: sensors for Zone 2 (ATEX/NEPSI)

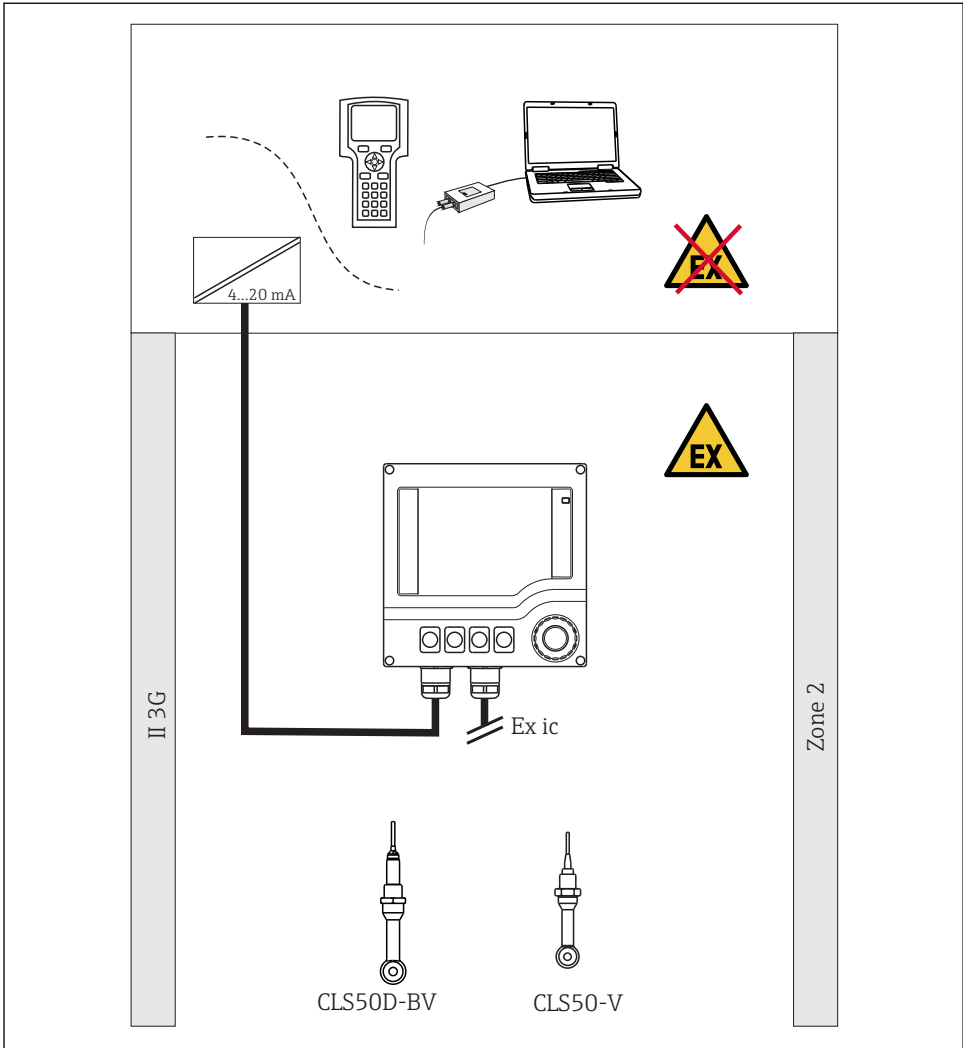

A0010316

### 5.1.5 Sensors with FM or CSA approval

The instructions in the Control Drawing apply for sensors with FM or CSA approval. You can find the Control Drawing in the Operating Instructions of the transmitter used.

## 5.2 Connecting the sensor

### 5.2.1 Direct connection, e.g. to CM42

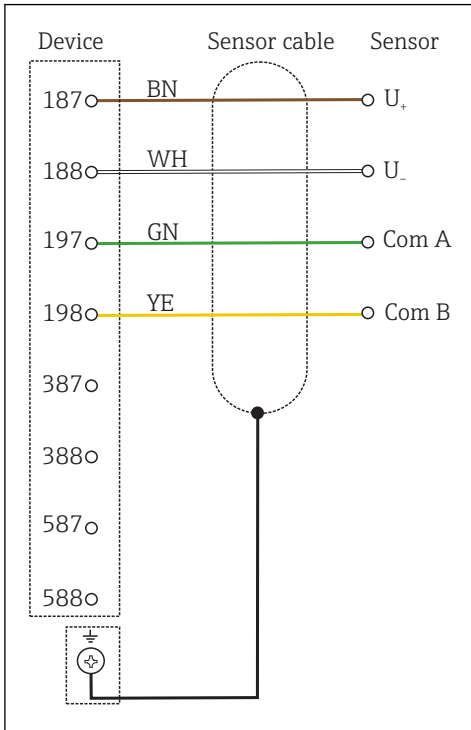

A0001078

7 CLS50D to CM42

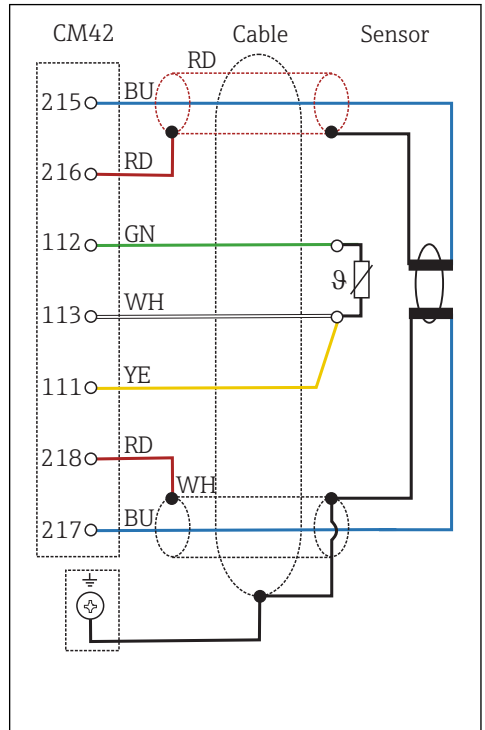

A0001082

8 CLS50 to CM42

### 5.2.2 Cable extension

The sensor is supplied with a fixed cable. The cable between the sensor and transmitter can be extended using the CYK11 (CLS50D) or CLK6 (CLS50) measuring cable (does not apply for use in a hazardous environment).

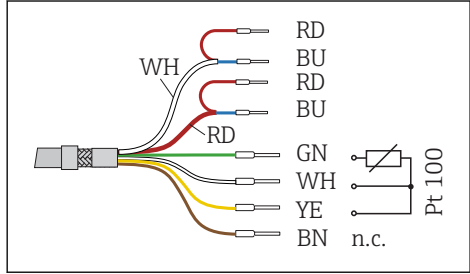
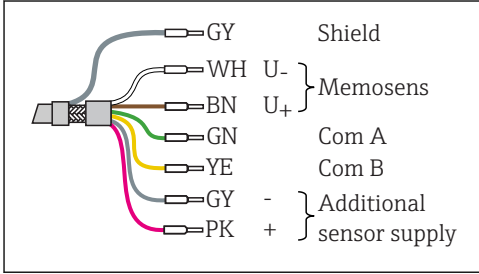

9 CYK11 for extension of CLS50D

10 CLK6 for extension of CLS50

Total cable length (max.): 100 m (330 ft)

Total cable length (max.): 55 m (180 ft)

**i** CLS50 only:  
The residual coupling of the sensor increases when the fixed cable is extended.

### 5.3 Ensuring the degree of protection

Only the mechanical and electrical connections which are described in these instructions and which are necessary for the required, designated use, may be carried out on the device delivered.

- ▶ Exercise care when carrying out the work.

Otherwise, the individual types of protection (Ingress Protection (IP), electrical safety, EMC interference immunity) agreed for this product can no longer be guaranteed due, for example to covers being left off or cable (ends) that are loose or insufficiently secured.

### 5.4 Post-connection check

Device condition and specifications	Action
Are the sensor, assembly, or cables free from damage on the outside?	▶ Perform a visual inspection.
Electrical connection	Action
Are the mounted cables strain-relieved and not twisted?	▶ Untwist the cables.
Is a sufficient length of the cable cores stripped, and are the cores positioned in the terminal correctly?	▶ Pull gently to check they are seated correctly.
Are all the screw terminals properly tightened?	▶ Tighten the screw terminals.
Are all cable entries mounted, tightened and leak-tight?	In the case of lateral cable entries:
Are all cable entries installed downwards or mounted laterally?	▶ Point cable loops downward so that water can drip off.

## 6 Commissioning

Prior to initial commissioning, ensure that:

- The sensor is correctly installed
- The electrical connection is correct

If using an assembly with automatic cleaning function:

- ▶ Check that the cleaning medium (water or air, for example) is connected correctly.

### WARNING

#### Escaping process medium

Risk of injury from high pressure, high temperatures or chemical hazards!

- ▶ Before applying pressure to an assembly with cleaning system, ensure that the system has been connected correctly.
- ▶ If you cannot reliably establish the correct connection, do not install the assembly in the process.
  
- ▶ At the transmitter, enter all the settings specific to the parameters and measuring point.

The measuring point is then ready to measure.



Following commissioning, the sensor must be serviced at regular intervals, as only then can reliable measurement be guaranteed.



Operating Instructions for the transmitter used, such as BA01245C if using the Liquiline CM44x or CM44xR.

## 7 Maintenance

### WARNING

#### Thiocarbamide

Harmful if swallowed! Limited evidence of carcinogenicity! Possible risk of harm to the unborn child! Dangerous for the environment with long-term effects!

- ▶ Wear protective goggles, protective gloves and appropriate protective clothing.
- ▶ Avoid all contact with the eyes, mouth and skin.
- ▶ Avoid discharge into the environment.

Clean away fouling on the sensor as follows depending on the type of fouling:

#### 1. Oily and greasy films:

Clean with fat solvent, e.g. alcohol, or hot water and agents containing surfactants (alkaline) (e.g. dishwashing detergent).

#### 2. Lime and metal hydroxide buildup and low solubility (lyophobic) organic buildup:

Dissolve buildup with diluted hydrochloric acid (3 %) and then rinse thoroughly with plenty of clear water.

3. Sulfidic buildup (from flue gas desulfurization or wastewater treatment plants):  
Use a mixture of hydrochloric acid (3 %) and thiocarbamide (commercially available) and then rinse thoroughly with plenty of clear water.
4. Buildup containing proteins (e.g. food industry):  
Use a mixture of hydrochloric acid (0.5 %) and pepsin (commercially available) and then rinse thoroughly with plenty of clear water.
5. Readily soluble biological buildup:  
Rinse with pressurized water.

After cleaning, rinse the sensor thoroughly with water.

## 8 Repair

### 8.1 Spare parts

	Item No.	Spare parts kit	Order No.
<p>A0025483</p>	150, 255	CHEMRAZ seal kit <ul style="list-style-type: none"> <li>▪ Nut (item 150)</li> <li>▪ CHEMRAZ O-ring, 2 pcs. (item 255)</li> </ul>	71086368
	150, 250	VITON seal kit <ul style="list-style-type: none"> <li>▪ Nut (item 150)</li> <li>▪ VITON O-ring, 3. pcs., (item 250)</li> </ul>	71086369
	260	PTFE disk kit for DN 50	71086372
	270	PTFE disk kit for ANSI 2" and JIS 10K 50A	71086374
	150, 280	Fixed flange kit, DN 50, stainless steel 1.4404 (AISI 316L) <ul style="list-style-type: none"> <li>▪ Nut (item 150)</li> <li>▪ Flange DN 50 (item 280)</li> </ul>	51500525
	150, 285	Fixed flange kit, ANSI 2", stainless steel 1.4404 (AISI 316L) <ul style="list-style-type: none"> <li>▪ Nut (item 150)</li> <li>▪ Flange ANSI 2" (item 285)</li> </ul>	51500527
	150, 286	Fixed flange kit, JIS, stainless steel 1.4404 (AISI 316L) <ul style="list-style-type: none"> <li>▪ Nut (item 150)</li> <li>▪ Flange DN 50 (item 286)</li> </ul>	51500934



	Item No.	Spare parts kit	Order No.
<p>A0025484</p>	150, 288, 292	Lap joint flange kit, ANSI 2", PVDF <ul style="list-style-type: none"> <li>▪ Nut (item 150)</li> <li>▪ Flange ANSI 2", PVDF (item 288)</li> <li>▪ Lap joint flange, UP-GF (item 292)</li> </ul>	51500937
	150, 287, 291	Lap joint flange kit, DN 50, PVDF <ul style="list-style-type: none"> <li>▪ Nut (item 150)</li> <li>▪ Flange DN 50, PVDF (item 287)</li> <li>▪ Lap joint flange, UP-GF (item 291)</li> </ul>	51500936
	150, 289, 293	Lap joint flange kit, JIS, PVDF <ul style="list-style-type: none"> <li>▪ Nut (item 150)</li> <li>▪ Flange JIS, PVDF (item 289)</li> <li>▪ Lap joint flange, UP-GF (item 293)</li> </ul>	51500935

## 8.2 Return

The product must be returned if repairs or a factory calibration are required, or if the wrong product was ordered or delivered. As an ISO-certified company and also due to legal regulations, Endress+Hauser is obliged to follow certain procedures when handling any returned products that have been in contact with medium.

To ensure the swift, safe and professional return of the device:

- ▶ Refer to the website [www.endress.com/support/return-material](http://www.endress.com/support/return-material) for information on the procedure and conditions for returning devices.

## 8.3 Disposal

The device contains electronic components. The product must be disposed of as electronic waste.

- ▶ Observe the local regulations.

## 9 Accessories

The following are the most important accessories available at the time this documentation was issued.

- ▶ For accessories not listed here, please contact your Service or Sales Center.

## 9.1 Measuring cable

### 9.1.1 For CLS50D

#### Memosens data cable CYK11

- Extension cable for digital sensors with Memosens protocol
- Product Configurator on the product page: [www.endress.com/cyk11](http://www.endress.com/cyk11)



Technical Information TI00118C

### 9.1.2 For CLS50

#### Measuring cable CLK6

- Extension cable for inductive conductivity sensors, for extension via VBM junction box
- Sold by the meter, order number: 71183688

#### VBM

- Junction box for cable extension
- 10 terminal strips
- Cable entries: 2 x Pg 13.5 or 2 x NPT ½"
- Material: aluminum
- Degree of protection: IP 65
- Order numbers
  - Cable entries Pg 13.5 : 50003987
  - Cable entries NPT ½": 51500177

## 9.2 Assemblies

### Dipfit CLA111

- Immersion assembly for open and closed vessels with flange DN 100
- Product Configurator on the product page: [www.products.endress.com/cla111](http://www.products.endress.com/cla111)



Technical Information TI00135C

### Dipfit CLA140

- For the CLS50/CLS50D inductive sensor
- Immersion assembly with flange connection for very demanding processes
- Product Configurator on the product page: [www.products.endress.com/cla140](http://www.products.endress.com/cla140)



Technical Information TI00196C

### Flexdip CYA112

- Immersion assembly for water and wastewater
- Modular assembly system for sensors in open basins, channels and tanks
- Material: PVC or stainless steel
- Product Configurator on the product page: [www.endress.com/cya112](http://www.endress.com/cya112)



Technical Information TI00432C

## 9.3 Calibration solutions

### Conductivity calibration solutions CLY11

Precision solutions referenced to SRM (Standard Reference Material) by NIST for qualified calibration of conductivity measuring systems in accordance with ISO 9000

- CLY11-B, 149.6  $\mu\text{S}/\text{cm}$  (reference temperature 25 °C (77 °F)), 500 ml (16.9 fl.oz)  
Order No. 50081903
- CLY11-C, 1.406 mS/cm (reference temperature 25 °C (77 °F)), 500 ml (16.9 fl.oz)  
Order No. 50081904
- CLY11-D, 12.64 mS/cm (reference temperature 25 °C (77 °F)), 500 ml (16.9 fl.oz)  
Order No. 50081905
- CLY11-E, 107.00 mS/cm (reference temperature 25 °C (77 °F)), 500 ml (16.9 fl.oz)  
Order No. 50081906



Technical Information TI00162C

## 10 Technical data

### 10.1 Input

#### 10.1.1 Measured variables

- Conductivity
- Temperature

#### 10.1.2 Measuring range

Conductivity	2 $\mu\text{S}/\text{cm}$ to 2000 mS/cm (uncompensated)
Temperature	-20 to +180 °C (-4 to +350 °F)

#### 10.1.3 Cell constant

$k = 1.98 \text{ cm}^{-1}$

#### 10.1.4 Measuring frequency

2 kHz

#### 10.1.5 Temperature measurement

### CLS50D

Pt1000 (Class A according to IEC 60751)

### CLS50

Pt100 (Class A according to IEC 60751)

## 10.2 Performance characteristics

### 10.2.1 Conductivity response time

$t_{95} \leq 2 \text{ s}$

### 10.2.2 Temperature response time

PEEK version:  $t_{90} \leq 7 \text{ min}$

PFA version:  $t_{90} \leq 11 \text{ min}$

### 10.2.3 Maximum measured error

-20 to 100 °C (-4 to 212 °F):  $\pm(5 \text{ }\mu\text{S/cm} + 0.5 \% \text{ of reading})$

> 100 °C (212 °F):  $\pm(10 \text{ }\mu\text{S/cm} + 0.5 \% \text{ of reading})$

### 10.2.4 Repeatability

For  $T < 100 \text{ }^\circ\text{C}$  (212 °F): 0.2 % of reading + 1  $\mu\text{S/cm}$

For  $T > 100 \text{ }^\circ\text{C}$  (212 °F): 0.2 % of reading + 2  $\mu\text{S/cm}$

### 10.2.5 Linearity

1.9 % (only applies in the 1 to 20 mS/cm measuring range)

## 10.3 Environment

### 10.3.1 Ambient temperature

#### CLS50D

-10 to +60 °C (+10 to +140 °F)

#### CLS50

-10 to +70 °C (+10 to +160 °F)

### 10.3.2 Storage temperature

-20 to +80 °C (0 to +180 °F)

### 10.3.3 Degree of protection

IP 68 / NEMA type 6 (sensor in installed state with genuine seal)

## 10.4 Process

### 10.4.1 Process temperature

Sensor material	CLS50D-*1/2 Without flange	CLS50D-*3/4/5/6/8 DN50, ANSI 2"	CLS50D-*7 JIS	CLS50D-*A/B/C PVDF lap joint flange
PEEK	-20 to 125 °C (-4 to 260 °F)	-20 to 125 °C (-4 to 260 °F)	-20 to 125 °C (-4 to 260 °F)	-20 to 125 °C (-4 to 260 °F)
PFA	-20 to 110 °C (-4 to 230 °F)	-20 to 110 °C (-4 to 230 °F)	-20 to 110 °C (-4 to 230 °F)	-20 to 110 °C (-4 to 230 °F)

### CLS50

Sensor material	CLS50-*1/2 Without flange	CLS50-*3/4/5/6/8 DN50, ANSI 2"	CLS50-*7 JIS	CLS50-*A/B/C PVDF lap joint flange
PEEK	-20 to 180 °C (-4 to 360 °F)	-20 to 180 °C (-4 to 360 °F)	-20 to 180 °C (-4 to 360 °F)	-20 to 125 °C (-4 to 260 °F)
PFA	-20 to 125 °C (-4 to 260 °F)	-20 to 125 °C (-4 to 260 °F)	-20 to 125 °C (-4 to 260 °F)	-20 to 125 °C (-4 to 260 °F)

### 10.4.2 Process pressure (absolute)

Max. 21 bar (305 psi), depending on the sensor version, see pressure-temperature ratings

### 10.4.3 Temperature/pressure ratings

#### CLS50D

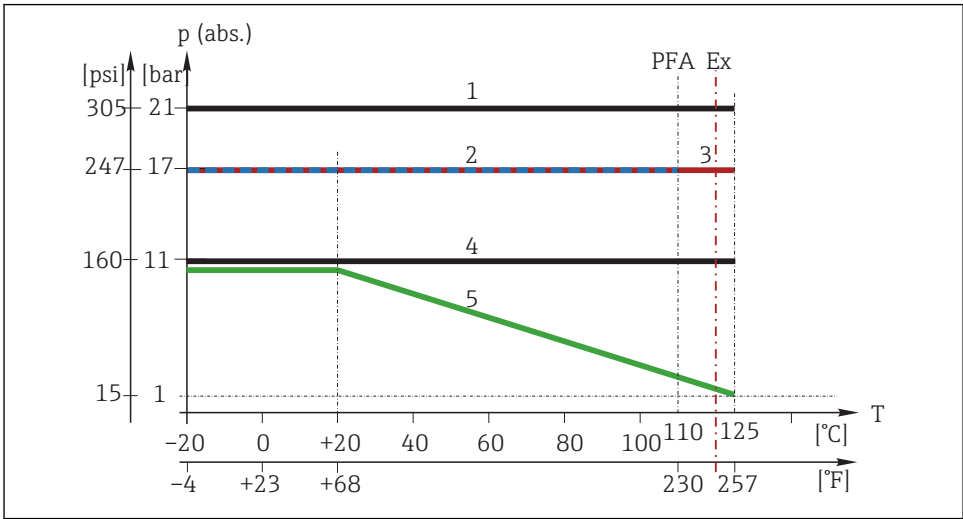

A0024981

11 Pressure temperature ratings CLS50D

- 1 PEEK sensor, without a flange
- 2 PFA sensor, without a flange (blue line)
- 3 PEEK or PFA sensor, with DN50/ANSI 2" flange (red line)
- 4 PEEK or PFA sensor, with JIS flange
- 5 PEEK or PFA sensor, with PVDF lap joint flange (green line)

## CLS50

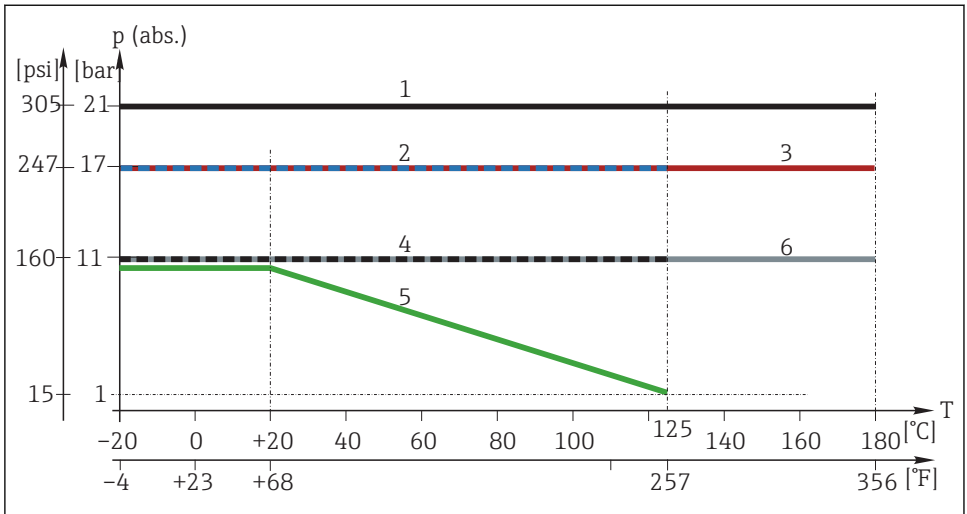

A0024979

12 Pressure-temperature ratings for CLS50

- 1 PEEK sensor, without a flange
- 2 PFA sensor, without a flange or with DN50/ANSI 2" flange (blue line)
- 3 PEEK sensor, with DN50/ANSI 2" flange (red line)
- 4 PFA sensor, with JIS flange (black line)
- 5 PEEK or PFA sensor, with PVDF lap joint flange (green line)
- 6 PEEK sensor, with JIS flange (gray line)

## 10.5 Mechanical construction

### 10.5.1 Weight

Approx. 0.65 kg (1.43 lbs)

### 10.5.2 Materials

Sensor	PEEK, PFA (depending on version)
Sensor seal	VITON, CHEMRAZ (depending on version)

Process connections	
G $\frac{3}{4}$	CLS50D-*1B/C**: PEEK GF30 CLS50D-*1D**: stainless steel (AISI 316Ti) CLS50-*1A*: stainless steel 1.4571 (AISI 316Ti) CLS50-*1B/C/1/2/3: PEEK GF30 CLS50-*1B/C/5/6: stainless steel 1.4571 (AISI 316Ti)
NPT 1"	PEEK
Fixed flange	Stainless steel 1.4404 (AISI 316L)
Sealing disk	GYLON (PTFE ceramic-filled)
Lap joint flange	PP-GF
Flange combined with lap joint flange	PVDF

### 10.5.3 Process connections

- G $\frac{3}{4}$  thread
- NPT 1" thread
- Lap joint flange EN 1092 DN50 PN10
- Lap joint flange ANSI 2" 150 lbs
- Lap joint flange JIS 10K 50A
- Flange EN 1092-1 DN50 PN16
- Flange ANSI 2" 300 lbs
- Flange JIS 10K 50A

### Flange dimensions

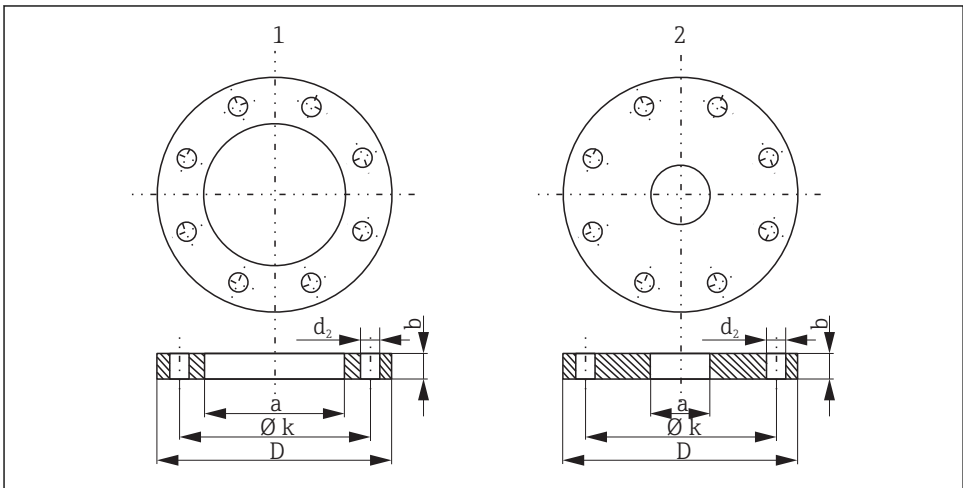

A0024986

13 Flange dimensions

- 1 Lap joint flange (PP-GF)
- 2 Fixed flange (stainless steel)



*Dimensions in mm*

Lap joint flange PP-GF	DN50 PN10	ANSI 2" 150 lbs	JIS 10K 50A
D	165	165	152
Ø k	125	121	120
d <sub>2</sub>	4 x 18	8 x 19	4 x 19
b	18	18	18
a	78	78	78
Screws	M16	M16	M16

*Dimensions in mm*

Fixed flange SS 316 L	DN50 PN10	ANSI 2" 300 lbs	JIS 10K 50A
D	165	165.1	155
Ø k	125	127	120
d <sub>2</sub>	4 x 18	8 x 19	4 x 19
b	18	22.2	16
a	27	27	27
Screws	M16	M16	M16

**10.5.4 Chemical resistance**

Medium	Concentration	PEEK	PFA	CHEMRAZ	VITON
Sodium hydroxide solution NaOH	0 to 50 %	20 to 100 °C (68 to 212 °F)	20 to 50 °C (68 to 122 °F)	0 to 150 °C (32 to 302 °F)	Not suitable
Nitric acid HNO <sub>3</sub>	0 to 10 %	20 to 100 °C (68 to 212 °F)	20 to 80 °C (68 to 176 °F)	0 to 150 °C (32 to 302 °F)	0 to 120 °C (32 to 248 °F)
	0 to 40 %	20 °C (68 °F)	20 to 60 °C (68 to 140 °F)	0 to 150 °C (32 to 302 °F)	0 to 120 °C (32 to 248 °F)
Phosphoric acid H <sub>3</sub> PO <sub>4</sub>	0 to 80 %	20 to 100 °C (68 to 212 °F)	20 to 60 °C (68 to 140 °F)	0 to 150 °C (32 to 302 °F)	0 to 120 °C (32 to 248 °F)
Sulfuric acid H <sub>2</sub> SO <sub>4</sub>	0 to 2.5 %	20 to 80 °C (68 to 176 °F)	20 to 100 °C (68 to 212 °F)	0 to 150 °C (32 to 302 °F)	0 to 120 °C (32 to 248 °F)
	0 to 30 %	20 °C (68 °F)	20 to 100 °C (68 to 212 °F)	0 to 150 °C (32 to 302 °F)	0 to 120 °C (32 to 248 °F)
Hydrochloric acid HCl	0 to 5 %	20 to 100 °C (68 to 212 °F)	20 to 80 °C (68 to 176 °F)	0 to 150 °C (32 to 302 °F)	0 to 120 °C (32 to 248 °F)
	0 to 10 %	20 to 100 °C (68 to 212 °F)	20 to 80 °C (68 to 176 °F)	0 to 150 °C (32 to 302 °F)	0 to 120 °C (32 to 248 °F)

# Index

## A

Accessories . . . . .	33
Air set . . . . .	20
Ambient temperature . . . . .	36
Approvals . . . . .	18
Marine . . . . .	19
Assembly . . . . .	24

## C

Cable extension . . . . .	30
Calibration solutions . . . . .	35
Cell constant . . . . .	35
Certificates . . . . .	18
Check . . . . .	
Connection . . . . .	30
Installation . . . . .	24
Chemical resistance . . . . .	41
Cleaning agent . . . . .	31
Conductivity response time . . . . .	36
Connection . . . . .	
Check . . . . .	30
Ensuring the degree of protection . . . . .	30
Connection conditions . . . . .	25

## D

Declaration of Conformity . . . . .	2, 18
Degree of protection . . . . .	36
Ensuring . . . . .	30
Designated use . . . . .	9
Direct connection to transmitter . . . . .	29
Disposal . . . . .	33

## E

Electrical connection . . . . .	24
Environment . . . . .	36
EU Declaration of Conformity . . . . .	2
Ex approvals . . . . .	18

## F

Flange . . . . .	21
------------------	----

## H

Hazardous areas . . . . .	10
---------------------------	----

## I

Incoming acceptance . . . . .	14
-------------------------------	----

Input . . . . .	35
Installation . . . . .	19
Installation conditions . . . . .	19
Installation factor . . . . .	19
Installation position . . . . .	19
Interpreting the order code . . . . .	17

## L

Linearity . . . . .	36
---------------------	----

## M

Maintenance . . . . .	31
Manufacturer's address . . . . .	17
Marine . . . . .	19
Materials . . . . .	39
Maximum measured error . . . . .	36
Measured variables . . . . .	35
Measuring frequency . . . . .	35
Measuring ranges . . . . .	35
Mechanical construction . . . . .	39

## N

Nameplate . . . . .	17
---------------------	----

## O

Operational safety . . . . .	10
------------------------------	----

## P

Performance characteristics . . . . .	36
Post-installation check . . . . .	24
Pressure/temperature ratings . . . . .	38
Process . . . . .	37
Process connections . . . . .	40
Process pressure . . . . .	37
Process temperature . . . . .	37
Product identification . . . . .	14, 17
Product page . . . . .	17
Product safety . . . . .	10

## R

Repair . . . . .	32
Repeatability . . . . .	36
Requirements for personnel . . . . .	9
Return . . . . .	33

**S**

## Safety

Electrical equipment in hazardous areas . . .	10
Safety instructions . . . . .	9
Scope of delivery . . . . .	17
Sensor	
Connecting . . . . .	29
Connection in hazardous area . . . . .	25
Mounting . . . . .	21
State-of-the-art technology . . . . .	10
Storage temperature . . . . .	36
Symbols . . . . .	7

**T**

Technical data . . . . .	35
Environment . . . . .	36
Mechanical construction . . . . .	39
Performance characteristics . . . . .	36
Process . . . . .	37
Temperature measurement . . . . .	35
Temperature response time . . . . .	36
Temperature/pressure ratings . . . . .	38
Type code . . . . .	14

**U**

Use . . . . .	9
---------------	---

**W**

Warnings . . . . .	7
Weight . . . . .	39
Wiring . . . . .	29
Workplace safety . . . . .	9



71464663

[www.addresses.endress.com](http://www.addresses.endress.com)

---