



There's an engineer behind everything we sell.

INSTRUMART

**BRAINCHILD ELECTRONIC CO LTD
PR SERIES PAPERLESS RECORDER SPECIFICATIONS**

**USA Contact & Support
Instrumart LLC**

35 Green Mountain Drive
South Burlington, VT 05403

Web: www.instrumart.com

Email: sales@instrumart.com

Tel: 1-800-884-4967

1.1.1 Accessories

Part no	Description
AI203	3-channel analog input card (TC, RTD, mA, V, mV)
AI206	6-channel analog input card (TC, RTD, mA, V, mV)
PC201	PID process control card
RO206	6-channel relay output card
DI206	6-channel digital input card
RD233	3-channel relay output and 3-channel digital input card
AO206	6-channel analog output card
IF232	RS-232 communication module for PR10 and PR20
IF485	RS-422/485 communication module for PR10 and PR20
IF232A	RS-232 communication module for PR30
IF485A	RS-422/485 communication module for PR30
PM201	90-250VAC 47-63Hz panel mount power supply board without power Switch for PR10 and PR20
PM202	90-250VAC 47-63Hz panel mount power supply board with power switch For PR10 and PR20
PM203	90-250VAC 47-63Hz portable power supply board with a power switch for PR10 and PR20
PM211	11-36VDC panel mount power supply board without power switch for PR10 and PR20
PM212	11-36VDC panel mount power supply board with a power switch for PR10 and PR20
PM213	11-36VDC portable power supply board with a power switch for PR10 and PR20
PM301	90-250VAC 47-63Hz panel mount power supply board without power Switch for PR30
PM302	90-250VAC 47-63Hz panel mount power supply board with power switch For PR30
PM303	90-250VAC 47-63Hz portable power supply board with a power switch for PR30
PM311	11-36VDC panel mount power supply board without power switch for PR30
PM312	11-36VDC panel mount power supply board with a power switch for PR30
PM313	11-36VDC portable power supply board with a power switch for PR30

1-2 Accessories Ordering Code

Note:

- ❖ The rear slots of the recorder will accept certain Input or output cards only in any combination based on the selected model.
- ❖ The basic PC software is supplied free with the recorder. There is an additional charge for the extensive Data Acquisition Software and communication ports of RS-232/422/485.
- ❖ The Ordering Code for various standard model Recorders with an AC supply and without any additional options are as follows:
 - PR1003- 0A001000
 - PR2003- 0A001000
 - PR3006- 000A001000

1.2 Specifications

1.2.1 General Specifications

	PR10	PR20	PR30
Number of Analog Input	3,6	3,6,12,18,24	6,12,18,24,30,36,42,48
Input Signals	Thermocouples: J, K, T, E, B, R, S, N, L, U, P, W5, W3, LR, A1, A2, A3, M RTD: PT50, PT100, PT200, PT500, PT1000($\alpha=0.00385$), PT50, PT100($\alpha=0.00391$), JPT50, JPT100, JPT200, JPT500, JPT1000($\alpha=0.003916$), Cu10($\alpha=0.00427$), Cu50, Cu100($\alpha=0.00426, 0.00428$), Ni100, Ni200, Ni500, Ni1000($\alpha=0.00617$), Current(mA), Voltage (Volts, mV)		
Fastest Sampling rate	100msec/dot, Default setting: 1sec/dot		
Calibration Correction	On-site Calibration possible or using Offset and Gain for correction		
Power	90-250VAC, 47-63Hz, 52VA, 26W maximum 11-36VDC, 26VA, 26W maximum	90-250VAC, 47-63Hz, 110VA, 62W maximum, 11-36VDC, 62VA, 62W maximum (UL Certification Not available)	
Display Size	4.3"	5.6"	12.1"
Display Type	65K Colour, TFT Touch Screen		
Display Resolution	480 x 272	640 x 480	1024 x 768
Backlight	LED		
Display MTBF @25°C	20000 Hours	60000 Hours	
CPU	ARM Cortex-A8, 1GHz		
Internal Memory	256MB		
External Storage	Max. Up to 32GB SD Card or USB Disk		
SD Card Slot	Standard one slot at Front		
USB Slot	Standard one USB slot in front and one USB slot in the rear		
Pulse Input	Optional DI card support pulse Input up to 100Hz		
PID Process Control	PID, Ramp & Dwell		
Math Channel	Available by Standard version		
External Channel, Batch, Custom Display, FDA 21 CFR Part 11	Available by plus versions		
Multilingual	Convenient for local users by offering languages in Brazil Portuguese, Chinese (Simplified, Traditional), Czech, Danish, Dutch, English, French, German, Greek, Italian, Japanese, Korean, Polish, Portuguese, Russian, Spanish, Swedish, Thai, Turkish. Other Languages are negotiable.		
Screen saver, Email	Available by Standard version		
Ethernet	Standard Ethernet Port. Modbus TCP/IP (Server by default, Client available with plus 1 version)		
RS-232/422/485	Optional Rs232 or Optional RS422/485. Modbus RTU (Slave by default, Master available with plus 1 version)		
PC Software	Standard: Historical Viewer + Configuration Optional: Extensive Software Data Acquisition Studio for real-time monitoring		



There's an engineer behind everything we sell.

INSTRUMART

1.2.2 Analog Input Specifications (AI203 & AI206)

Channels: AI203 ~ 3 channels, AI206 ~ 6 channels

Resolution: 24 bits

Sampling Rate: 10 times/ second (100milliseconds)

Maximum Rating:

- ❖ RTD input $\pm 20V$
- ❖ Thermocouple and Voltage input $\pm 50V$
- ❖ mA input $\pm 10V$

Temperature Effect:

- ❖ $\pm 0.1\mu V \pm 15PPM$ of reading for all inputs except mA
- ❖ $\pm 30PPM$ of reading for mA input

Sensor Lead Resistance Effect:

- ❖ **Thermocouple:** 0.32PPM of reading/ Ω
- ❖ **3-wire RTD:** 2.6 $^{\circ}C/\Omega$ of resistance difference of two leads (Based on $^{\circ}C$ measurement temperature for PT100)
- ❖ **2-wire RTD:** 2.6 $^{\circ}C/\Omega$ of resistance sum of two leads (Based on $^{\circ}C$ measurement temperature for PT100)

Burn-out Current: 10uA

Common Mode Rejection Ratio (CMRR): 120dB

Normal Mode Rejection Ratio (NMRR): 55dB

Isolation Breakdown Voltage between channels: 1500VAC min.

Sensor Break Detection:

- ❖ Sensor opened for TC, RTD and mV inputs
- ❖ Below 1 mA for 4-20mA input
- ❖ Below 0.25V for 1-5V inputs
- ❖ Not available for other inputs

Sensor Break Responding Time:

- ❖ Within 1 seconds for TC, RTD and mV inputs
- ❖ 0.1 second for 4-20 mA and 1-5V inputs



There's an engineer behind everything we sell.

INSTRUMART

Input Characteristics:

Type	Range	Accuracy at 25 °C	Input Impedance
J	-120 ~ 1000 °C (-184 ~ 1832 °F)	±1 °C	3.12MΩ
K	-200 ~ 1370 °C (-328 ~ 2498 °F)	±1 °C	3.12MΩ
T	-250 ~ 400 °C (-418 ~ 752 °F)	±1 °C	3.12MΩ
E	-100 ~ 900 °C (-148 ~ 1652 °F)	±1 °C	3.12MΩ
B	0 ~ 1820 °C (32 ~ 3308 °F)	±2 °C (200 ~ 1820 °C)	3.12MΩ
R	0 ~ 1768 °C (32 ~ 3214 °F)	±2 °C	3.12MΩ
S	0 ~ 1768 °C (32 ~ 3214 °F)	±2 °C	3.12MΩ
N	-250 ~ 1300 °C (-418 ~ 2372 °F)	±1 °C	3.12MΩ
L	-200 ~ 900 °C (-328 ~ 1652 °F)	±1 °C	3.12MΩ
U	-200 ~ 600 °C (-328 ~ 1112 °F)	±1 °C	3.12MΩ
P	0 ~ 1395 °C (32 ~ 2543 °F)	±1 °C	3.12MΩ
W5 or C	0 ~ 2315 °C (32 ~ 4199 °F)	±1 °C	3.12MΩ
W3	0 ~ 2315 °C (32 ~ 4199 °F)	±1 °C	3.12MΩ
LR	-200 ~ 800 °C (-328 ~ 1472 °F)	±1 °C	3.12MΩ
A1	0 ~ 2500 °C (-32 ~ 4532 °F)	±1 °C	3.12MΩ
A2	0 ~ 1800 °C (-32 ~ 3272 °F)	±1 °C	3.12MΩ
A3	0 ~ 1800 °C (-32 ~ 3272 °F)	±1 °C	3.12MΩ
M	-200 ~ 100 °C (-328 ~ 212 °F)	±1 °C	3.12MΩ
PT50 (α = 0.00385)	-200 ~ 850 °C (-328 ~ 1562 °F)	±0.4 °C	2.0KΩ
PT100 (α = 0.00385)	-200 ~ 850 °C (-328 ~ 1562 °F)	±0.4 °C	2.0KΩ
PT200 (α = 0.00385)	-200 ~ 850 °C (-328 ~ 1562 °F)	±0.4 °C	2.0KΩ
PT500 (α = 0.00385)	-200 ~ 850 °C (-328 ~ 1562 °F)	±0.4 °C	2.0KΩ
PT1000 (α = 0.00385)	-200 ~ 350 °C (-328 ~ 662 °F)	±0.4 °C	2.0KΩ
PT50 (α = 0.00391)	-200 ~ 850 °C (-328 ~ 1562 °F)	±0.4 °C	2.0KΩ
PT100 (α = 0.00391)	-200 ~ 850 °C (-328 ~ 1562 °F)	±0.4 °C	2.0KΩ
JPT50 (α = 0.003916)	-200 ~ 600 °C (-328 ~ 1112 °F)	±0.4 °C	2.0KΩ
JPT100 (α = 0.003916)	-200 ~ 600 °C (-328 ~ 1112 °F)	±0.4 °C	2.0KΩ
JPT200 (α = 0.003916)	-200 ~ 600 °C (-328 ~ 1112 °F)	±0.4 °C	2.0KΩ
JPT500 (α = 0.003916)	-200 ~ 600 °C (-328 ~ 1112 °F)	±0.4 °C	2.0KΩ
JPT1000 (α = 0.003916)	-200 ~ 350 °C (-328 ~ 662 °F)	±0.4 °C	2.0KΩ
Cu50 (α = 0.00426)	-50 ~ 200 °C (-58 ~ 392 °F)	±0.4 °C	2.0KΩ
Cu100 (α = 0.00426)	-50 ~ 200 °C (-58 ~ 392 °F)	±0.4 °C	2.0KΩ
Cu50 (α = 0.00428)	-180 ~ 200 °C (-292 ~ 392 °F)	±0.4 °C	2.0KΩ
Cu100 (α = 0.00428)	-180 ~ 200 °C (-292 ~ 392 °F)	±0.4 °C	2.0KΩ
Ni100 (α = 0.00617)	-60 ~ 180 °C (-76 ~ 356 °F)	±0.4 °C	2.0KΩ
Ni200 (α = 0.00617)	-60 ~ 180 °C (-76 ~ 356 °F)	±0.4 °C	2.0KΩ
Ni500 (α = 0.00617)	-60 ~ 180 °C (-76 ~ 356 °F)	±0.4 °C	2.0KΩ
Ni1000 (α = 0.00617)	-60 ~ 180 °C (-76 ~ 356 °F)	±0.4 °C	2.0KΩ
Cu10 (α = 0.00427)	-200 ~ 260 °C (-328 ~ 500 °F)	±0.1 °C	2.0KΩ
±20mA	-26 ~ 26mA	±0.05%	75Ω
±60mV	-122 ~ 122mV	±0.05%	3.12MΩ
±200mV	-243 ~ 243mV	±0.05%	3.12MΩ
±1V	-1.58 ~ 1.58mV	±0.05%	3.12MΩ
±2V	-3.16 ~ 3.16mV	±0.05%	3.12MΩ
±6V	-6.32 ~ 6.32V	±0.05%	3.12MΩ
±20V	-25.3 ~ 25.3V	±0.05%	3.12MΩ



There's an engineer behind everything we sell.

INSTRUMART

Type	Range	Accuracy at 25 °C	Input Impedance
±50V	-50.6 ~ 50.6V	±0.05%	3.12MΩ
0.4 ~ 2V	-3.16 ~ 3.16V	±0.05%	3.12MΩ
1 ~ 5V	-6.32 ~ 6.32V	±0.05%	3.12MΩ

1.2.3 Digital Input Specifications (DI206 & RD233)

Channels:

DI206: 6 Channels per card,

RD233: 3 Channels per card

Logic Low: -5V minimum, 0.8V maximum

Logic High: 3.5V minimum, 24V maximum

External pull-down Resistance: 1KΩ maximum

External pull-up Resistance: 1.5MΩ minimum

1.2.4 Relay Output Specifications (RO206 & RD206)

Channels:

RO206: 6 Channels per card,

RD233: 3 Channels per card

Contact Form: N.O. & N.C. (Form C)

Relay Rating: 5A/240 VAC, life cycles 200,000 for resistive load

1.2.5 Analog Output Specifications (AO206)

Channels: 6 Channels per card

Output signal: 4-20mA, 0-20mA, 0-5V, 1-5V, 0-10V

Resolution: 16 bits

Accuracy: ±0.05% of Span ±0.0025% /°C

Load Resistance: 0-500Ω (current), 10KΩ minimum (voltage)

Output Regulation: 0.01% for full load change

Output Setting Time: 0.1 second (stable to 99.9%)

Isolation Breakdown Voltage: 1500VAC at 50/60Hz for 1 minute

Integral Linearity Error: ±0.005% of Span

Temperature Effect: ±0.0025% of Span /°C

Note:

There are DIP switches available on the AO card to select the output type and the default setting is SET to Voltage output. For Current (mA) Output, SET 1to 5 (ON) and 6 to 8 (OFF).



There's an engineer behind everything we sell.

INSTRUMART

1.2.6 Real-time Clock

Item	Description
Make	Seiko Instruments
Model	MS621-fl11e
Rating	3V,4mAH
Typical Life Time	10 Years
Buffer Period	6 Months
Type	Rechargeable
Accuracy	Maximum \pm 2 Seconds/Day

1.9.9.1 Real-time Clock accuracy vs Temperature inside of the housing

Temperature Inside Housing	Typical Error / Month
10°C ~ 40 °C	18 Seconds
0°C or 50 °C	52 Seconds
-10°C or 60°C	107 Seconds

1.2.7 Environmental & Physical Specifications

Operating Temperature: 0 ~ 50 °C

Storage Temperature: -30 ~ 70 °C

Humidity: 20 to 90% RH (non-condensing)

Maximum relative humidity 90% is for ambient temperature up to 38°C decreasing linearly to 50% relative humidity at 50°C

Altitude: 2000 M maximum

Insulation Resistance: 20 MΩ min. (at 500 VDC)

Dielectric Strength: 2300VAC, 50/60 Hz for 1 minute between power terminal and earth

Vibration Resistance: 10-55 Hz, 10m/ s² for 2 hours

Shock Resistance: 30m/ s² (3g) for operation, 20g for transportation



There's an engineer behind everything we sell.

INSTRUMART

Operation Position: no inclined restriction

Dimensions: Panel Mount style: PR10/PR20:144(W) x 144(H) x 193mm (D)
PR30:288(W) x 288(H) x 194mm (D)

Standard Panel Cut-out: PR10/PR20:137 x 137mm
PR30:281 x 281mm

1.2.8 Approval Standards

Safety:

UL61010C-1, CSA C22.2 No. 24-93

CE: EN61010-1 (IEC1010-1) over voltage category II, Pollution degree 2

Protective Class:

IP 65 front panel for indoor use

IP 20 housing and terminals

EMC:

Emission: EN61326-1 (EN55022 class A, EN61000-3-2, EN61000-3-3)

Immunity: EN61326-1 (EN61000-4-2, EN61000-4-3, EN61000-4-4,
EN61000-4-5, EN61000-4-6, EN61000-4-8, EN61000-4-11)

2. Installation and wiring

 Sometimes dangerous voltages capable of causing death are present in this instrument. Before doing the installation or any troubleshooting procedures, the power to the equipment must be switched off and isolated. Units suspected of being faulty must be disconnected and removed to a properly equipped workshop for testing and repair. Component replacement and internal adjustments must be made by a qualified maintenance person only.

 To minimize the possibility of fire or shock hazards, do not expose this instrument to rain or excessive moisture.

 Do not use this instrument in areas under hazardous conditions such as excessive shock, vibration, dirt, moisture, corrosive gases or oil. The ambient temperature of the area should not exceed the maximum rating specified in the specification

 Remove stains from this equipment using a soft, dry cloth. Do not use harsh chemicals, volatile solvents such as thinner or strong detergents to clean the equipment in order to avoid deformation.

 If the equipment is used in a manner not specified by the manufacturer, the protection provided by the equipment may be impaired.

2.1 Unpacking

Upon receipt of the shipment, remove the recorder from the carton and inspect the unit for shipping damage. If any damage is found, contact your local representative immediately. Note the model number and serial number for future reference when corresponding with our service center. The serial number (S/N) is labelled on the box and the housing of the recorder.

The recorder is designed for indoor use only and is not intended for use in any hazardous area. It should be kept away from shock, vibration, and electromagnetic fields (such as variable frequency drives), motors and transformers. It is intended to operate under the following environmental conditions.

Environmental Parameter	Specification
Operating Temperature	0°C to 50 °C
Humidity	20% to 90% RH(Non-condensing)
Altitude	2000 M Maximum
Pollution Degree Level II	IEC1010-1(EN61010-1)
Power	90 ~ 250 VAC, 50/60 Hz or 11-36VDC

2.2 Dimensions

2.2.1 Panel mounting style

2.2.1.1 PR10

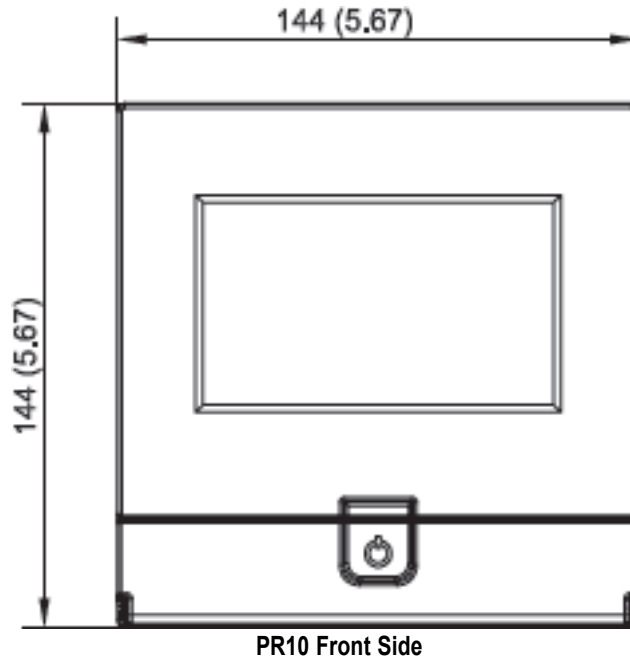

2-1



There's an engineer behind everything we sell.

INSTRUMART

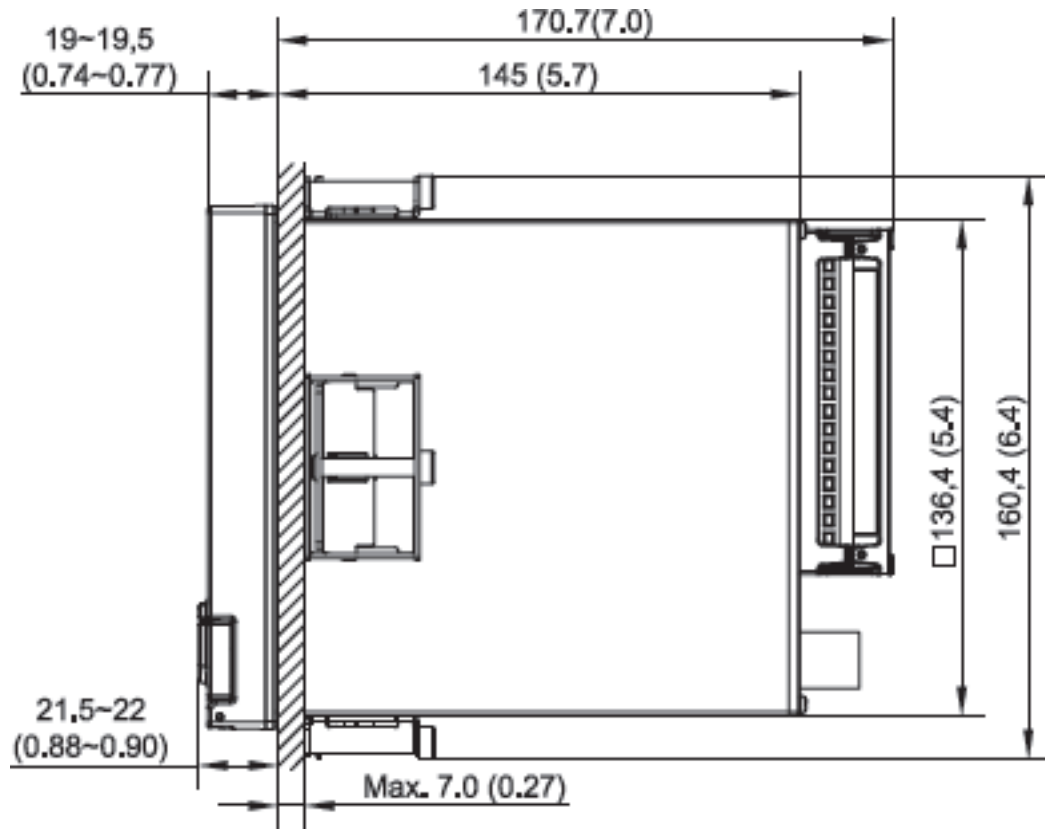

2-2

PR10 Right Side



There's an engineer behind everything we sell.

INSTRUMART

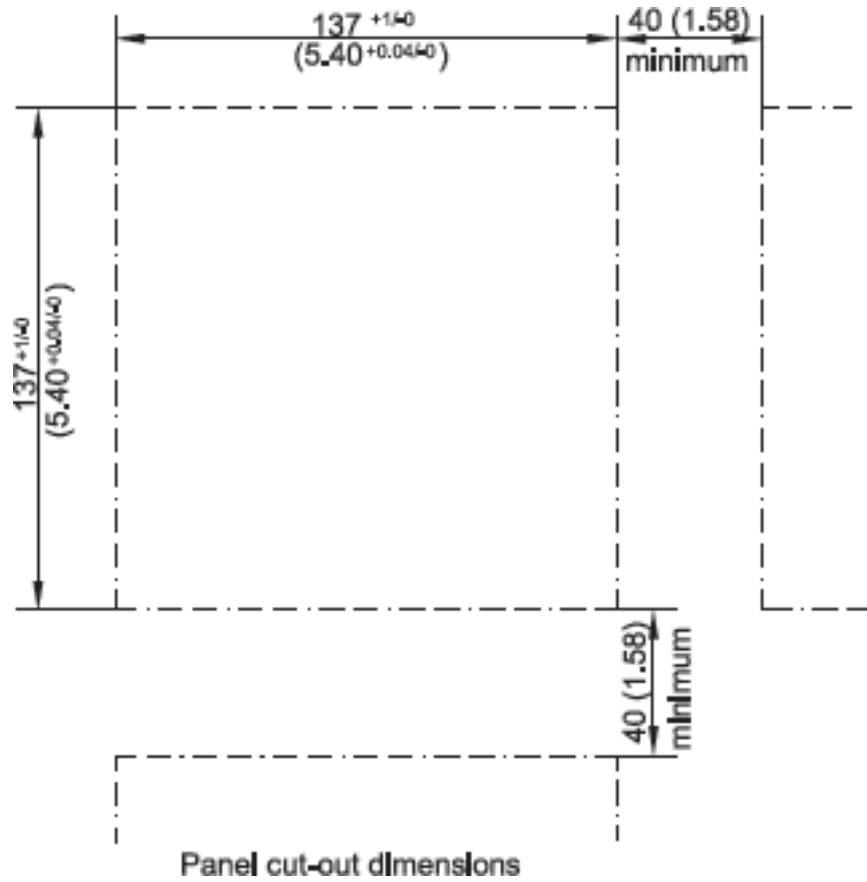

2-3

PR10 Panel Cut-out Dimensions



There's an engineer behind everything we sell.

INSTRUMART

2.2.1.2 PR20

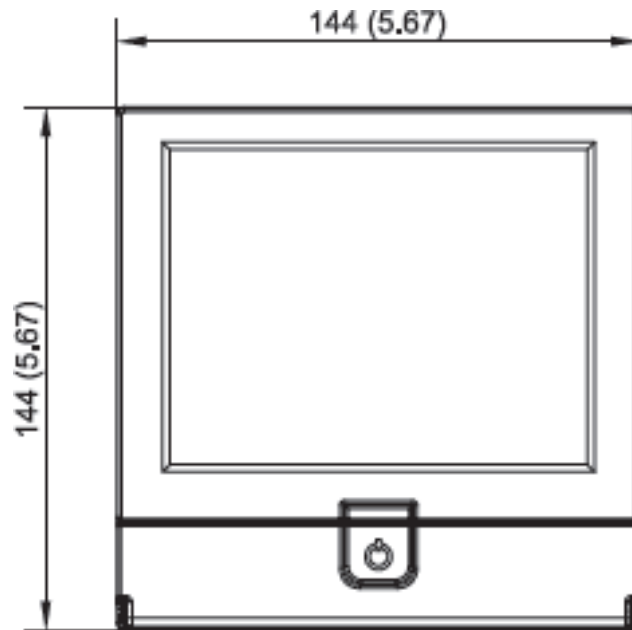

2-4

PR20 Front Side

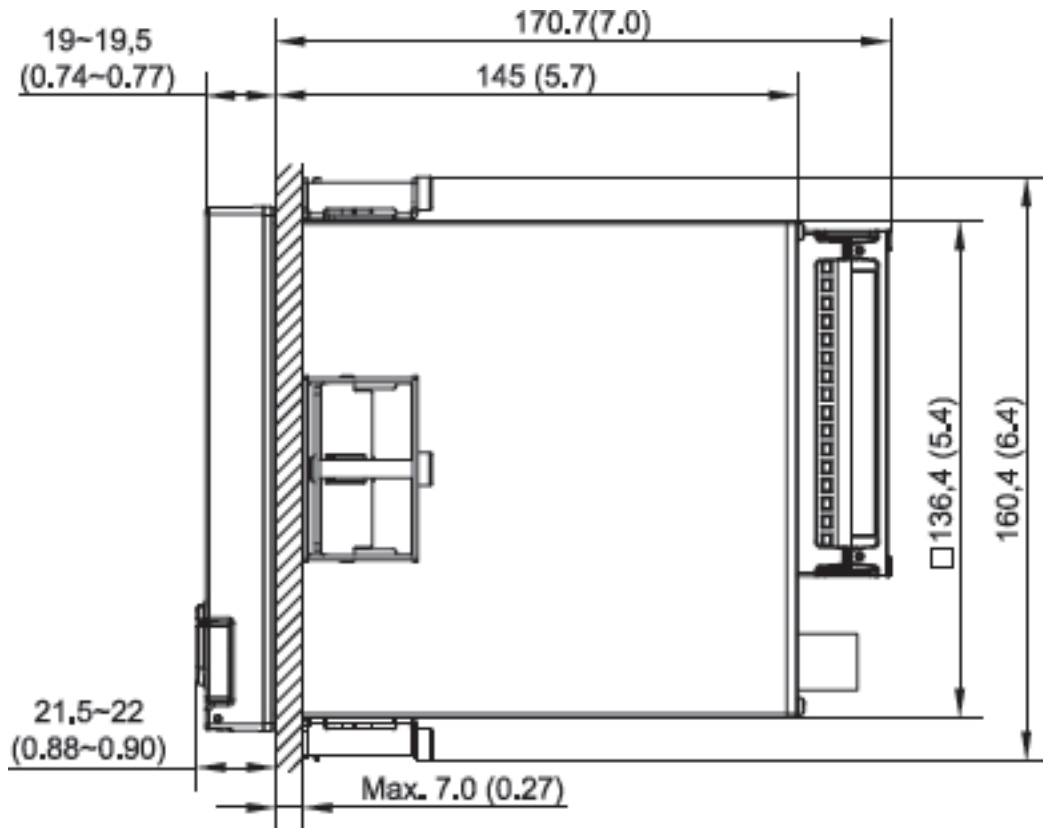



There's an engineer behind everything we sell.

INSTRUMART

2-5

PR20 Right Side

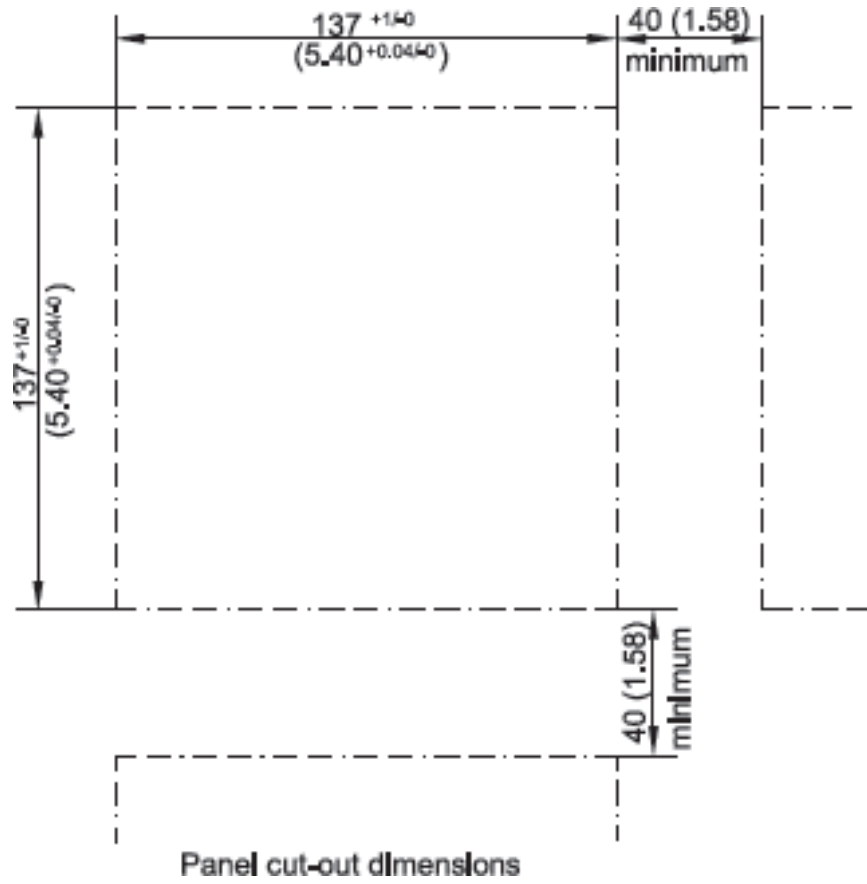

2-6

PR20 Panel Cut-out Dimensions



There's an engineer behind everything we sell.

INSTRUMART

2.2.1.3 PR30

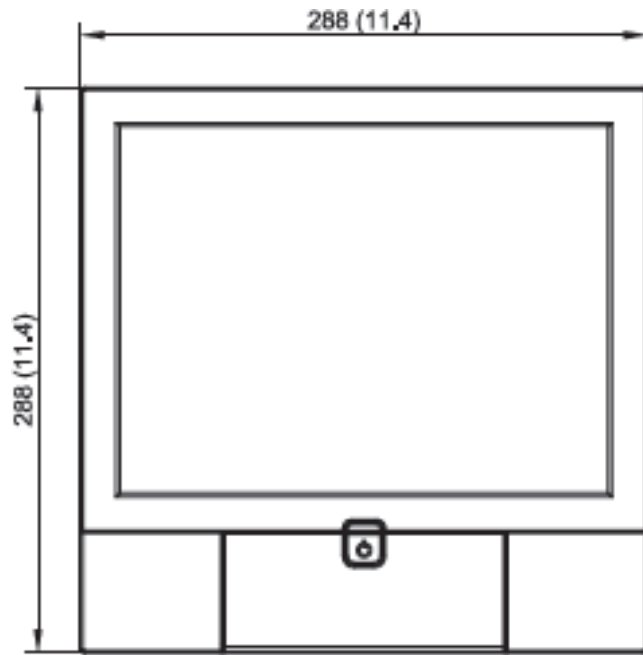

2-7 PR30 Front Side

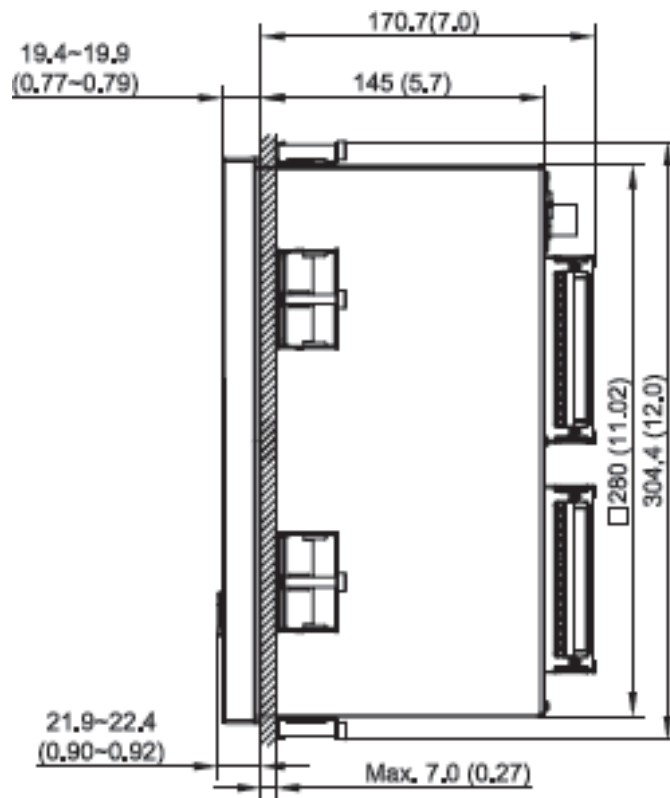

2-8

PR30 Right Side



There's an engineer behind everything we sell.

INSTRUMART

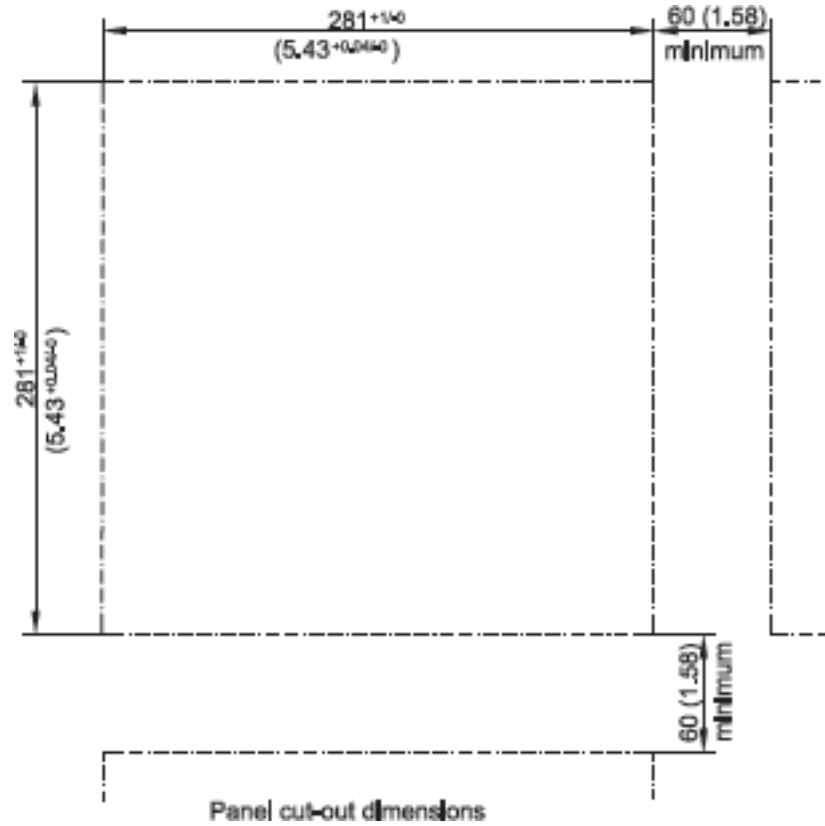

2-9 PR30 Cut-out Dimensions

Note:

- ❖ Do not over tighten mounting clamp screws that could result in distortion of the case.
- ❖ There is no mounting angle restriction.
- ❖ The mounting torque used for 4 sides of the housing should be 2.0 kgf-cm and not more than 2.5 Kgf-cm

2.2.2 Portable styles



PR10



PR20



PR30



There's an engineer behind everything we sell.

INSTRUMART

2.2.2.1 Bottom Side View of PR20 & PR10

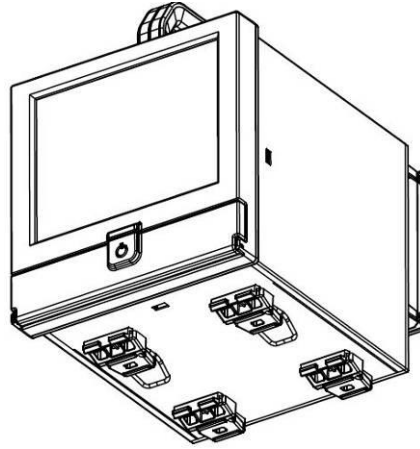

2-10 PR10 & PR20 Portable Type Bottom Side View

2.2.2.2 Front Side View of PR20 & PR10

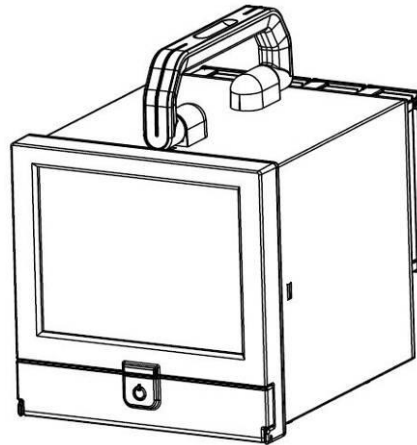

2-11 PR10 & PR20 Portable Type Front Side View



There's an engineer behind everything we sell.

INSTRUMART

2.2.2.3 Bottom Side View of PR30

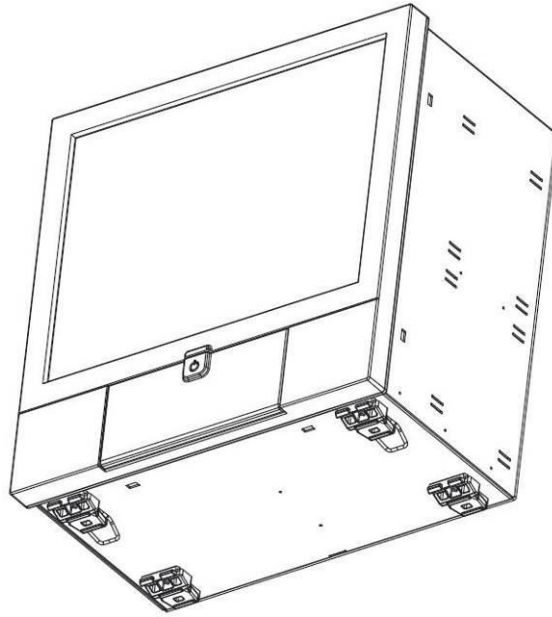

2-12 PR30 Portable Type Bottom Side View

2.2.2.4 Front Side View of PR30

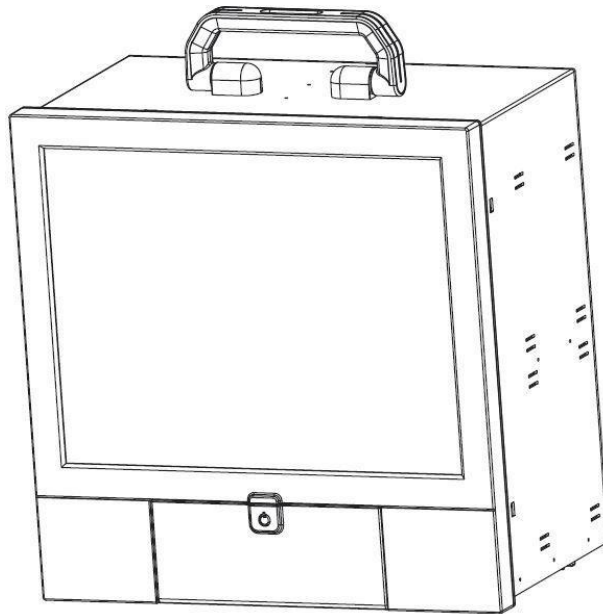

2-13

PR30 Portable Type Front Side View