



GDA-400 4-Channel Controller

Instruction 5700-9000
Installation / Operation / Maintenance
Rev. 1 – September 2012



WARRANTY

Bacharach, Inc. warrants to Buyer that at the time of delivery this Product will be free from defects in material and manufacture and will conform substantially to Bacharach Inc.'s applicable specifications. Bacharach's liability and Buyer's remedy under this warranty are limited to the repair or replacement, at Bacharach's option, of this Product or parts thereof returned to Seller at the factory of manufacture and shown to Bacharach Inc.'s reasonable satisfaction to have been defective; provided that written notice of the defect shall have been given by Buyer to Bacharach Inc. within one (1) year after the date of delivery of this Product by Bacharach, Inc.

Bacharach, Inc. warrants to Buyer that it will convey good title to this Product. Bacharach's liability and Buyer's remedy under this warranty of title are limited to the removal of any title defects or, at the election of Bacharach, to the replacement of this Product or parts thereof that are defective in title.

The warranty set forth in Paragraph 1 does not apply to parts the Operating Instructions designate as having a limited shelf-life or as being expended in normal use (e.g., filters).

THE FOREGOING WARRANTIES ARE EXCLUSIVE AND ARE GIVEN AND ACCEPTED IN LIEU OF (I) ANY AND ALL OTHER WARRANTIES, EXPRESS OR IMPLIED, INCLUDING WITHOUT LIMITATION THE IMPLIED WARRANTIES OF MERCHANTABILITY AND FITNESS FOR A PARTICULAR PURPOSE; AND (II) ANY OBLIGATION, LIABILITY, RIGHT, CLAIM OR REMEDY IN CONTRACT OR TORT, WHETHER OR NOT ARISING FROM BACHARACH'S NEGLIGENCE, ACTUAL OR IMPLIED. The remedies of the Buyer shall be limited to those provided herein to the exclusion of any and all other remedies including, without limitation incidental or consequential damages. No agreement varying or extending the foregoing warranties, remedies or this limitation will be binding upon Bacharach, Inc. unless in writing, signed by a duly authorized officer of Bacharach.

**Register your warranty by visiting
www.MyBacharach.com**

NOTICE

Product improvements and enhancements are continuous; therefore the specifications and information contained in this document may change without notice.

Bacharach, Inc. shall not be liable for errors contained herein or for incidental or consequential damages in connection with the furnishing, performance, or use of this material.

No part of this document may be photocopied, reproduced, or translated to another language without the prior written consent of Bacharach, Inc.

Copyright © 2012, Bacharach, Inc., All Rights Reserved

BACHARACH® is a registered trademark of Bacharach, Inc. All other trademarks, trade names, service marks and logos referenced herein belong to their respective owners.

TABLE OF CONTENTS

| | | |
|----------|----------------------------------------------------------|-----------|
| 1 | IMPORTANT SAFETY ISSUES | 5 |
| 2 | GENERAL DESCRIPTION | 7 |
| 2.1 | Data Display Screens..... | 8 |
| 2.1.1 | Engineering Unit Screen | 8 |
| 2.1.2 | Bar Graph Screen..... | 8 |
| 2.1.3 | Trend Screen | 9 |
| 2.2 | Specifications..... | 9 |
| 2.2.1 | Power Supply Requirements | 9 |
| 2.2.2 | Relays | 9 |
| 2.2.3 | Ambient Temperature Range..... | 10 |
| 2.2.4 | Humidity Range | 10 |
| 2.2.5 | Altitude..... | 10 |
| 2.2.6 | Housings / Installation Categories..... | 10 |
| 2.2.7 | Approvals..... | 10 |
| 2.3 | Accessories 11 | |
| 3 | BASIC OPERATION | 12 |
| 3.1 | Setup Menu Configuration | 12 |
| 3.2 | Changing Menu Variables Using the Keypad | 12 |
| 3.2.1 | GDA-400 Setup Configuration Menus | 14 |
| 3.2.2 | Channel Setup Entry Menu | 14 |
| 3.2.3 | Fault / Alarm 1 / Alarm 2 / Alarm 3 Set-up Menus..... | 14 |
| 3.2.4 | Configure Menu to Define Channel..... | 15 |
| 3.2.4.1 | Name / EUnits ASCII Data Fields..... | 16 |
| 3.2.4.2 | Input Measurement Range..... | 16 |
| 3.2.4.3 | Decimal Point Resolution | 16 |
| 3.2.4.4 | Turning Off Unused Channels..... | 16 |
| 3.2.5 | CAL Setup Menu | 17 |
| 3.2.6 | Calibrate Input Menu | 17 |
| 3.3 | System Configuration Menus..... | 18 |
| 3.3.1 | Standard / Optional Relay Setup Menus | 19 |
| 3.3.2 | Relay 2 ACK (Acknowledge) / Horn Setup Menu..... | 20 |
| 3.3.3 | Clock / Delays Menu..... | 20 |
| 3.3.4 | Communications Menu | 21 |
| 3.3.5 | Analog Setup Menu | 21 |
| 3.4 | System Security Menu | 22 |
| 4 | DISPLAY TO DEVICE CONNECTIONS | 23 |
| 4.1 | Motherboard Interface PCB..... | 23 |
| 4.2 | Input / Output Optional PCBs | 24 |
| 4.2.1 | Optional Analog Input PCB # 5700-0014 | 25 |
| 4.2.2 | Optional Bridge Sensor Input Board #5700-0020 | 26 |
| 4.2.3 | Bridge Sensor Initial Setup | 26 |
| 4.2.4 | Optional Discrete Relay PCBs #5700-0015 | 27 |
| 4.2.5 | Optional 4-20mA Analog Output Board #5700-0019 | 28 |
| 4.3 | MODBUS RS-232 / RS-485 Interface Option #5700-0017 | 29 |
| 4.3.1 | MODBUS Register and Function Code Summary | 30 |
| 4.4 | Optional External 24VDC 50 Watt Power Supplies..... | 33 |
| 5 | WALL MOUNT ENCLOSURE | 34 |
| 6 | ADDING THE WIRELESS RADIO KIT OPTION | 35 |

| | | |
|----------|---------------------------------------------------|-----------|
| 6.1 | Introduction | 35 |
| 6.2 | Radio Setup Menu | 36 |
| 6.3 | Wireless Receiver Mode | 36 |
| 6.3.1 | Radio Status Alarms - Wireless Receiver Mode..... | 37 |
| 6.4 | Wireless Modbus Slave Mode | 37 |
| 6.5 | Antenna Selection..... | 38 |
| 6.5.1 | Dipole and Collinear Antennas..... | 38 |
| 6.5.2 | Yagi Antennas..... | 38 |
| 6.5.3 | Mounting Near Other Antennas..... | 39 |
| 6.5.4 | Coax Cables | 39 |
| 6.6 | Surge Protection and Grounding | 39 |
| 6.6.1 | Antenna Grounding..... | 40 |
| 6.6.2 | Connections to Other Equipment | 40 |
| 7 | SERVICE CENTERS | 41 |

1 Important Safety Issues

The following terms and symbols are used in this manual to alert the operator of important instrument operating issues.



This symbol is intended to alert the user to the presence of important operating and maintenance / servicing instructions.



This symbol is intended to alert the user to the presence of dangerous voltage amounts within the instrument enclosure that may be of sufficient magnitude to constitute a risk of electric shock.



This symbol signifies the system's ground terminal. DC refers to direct current voltages. VAC refers to alternating current voltages.

WARNINGS:



- Read and understand the contents of this manual prior to operation. Failure to do so could result in serious injury or death.
- **SHOCK HAZARD** - Disconnect or turn off power before servicing this instrument.
- NEMA 4X wall mount models should be fitted with a locking mechanism after installation to prevent access to high voltages by unauthorized personnel (see Figure 4.0).
- Only the combustible monitor portions of this instrument have been assessed by CSA for 122.2 No. 152 performance requirements.
- This equipment is suitable for use in Class I, Division 2, Groups A,B,C and D or non-hazardous locations only.



- **EXPLOSION HAZARD**- Substitution of components may impair suitability for Class I, Division 2.
- **EXPLOSION HAZARD**- Do not replace fuse unless power has been switched off or the area is known to be non-hazardous.
- **EXPLOSION HAZARD**- Do not disconnect equipment unless power has been switched off or the area is known to be non-hazardous.
- Use a properly rated CERTIFIED AC power cable installed as per local or national codes.
- For DC powered units, DC power must be from a SELV rated source.

- A certified AC power disconnect or circuit breaker should be mounted near the controller and installed following applicable local and national codes. If a switch is used instead of a circuit breaker, a properly rated CERTIFIED fuse or current limiter is required to be installed as per local or national codes. Markings for positions of the switch or breaker should state (I) for on and (O) for off.
- Clean using only a damp cloth with no solvents.
- Equipment not used as prescribed within this manual may impair overall safety.

2 General Description

The Bacharach, Inc. GDA-400 Four Channel Controller is designed to display and control alarm event switching for up to four inputs. Inputs are typically voltage or 4-20mA current from transmitters, monitors or other analog output devices. The GDA-400 is equipped with a Fault and three alarm levels per channel with features such as *ON / OFF* delays, latching relays and alarm *Acknowledge*. A dedicated horn driver circuit for a local audible annunciator is also standard. Two standard 5-amp alarm relays are able to be configured via the *Alarm Voting* menu to cause relays to trip based upon various alarm combinations. Real-Time Clock and Calendar are also standard. Options such as 4-20mA outputs, discrete relays for each alarm and audible annunciators are easily added. RS-485 (Modbus RTU) or Ethernet (Modbus TCP) ports are also available for sending data to PC's, PLC's, DCS's, or other Bacharach, Inc. controllers.

A 128 x 64 pixel graphic LCD readout displays monitored data as bar graphs, 30-minute trends and engineering units. System configuration is accomplished via user friendly menus and all configuration data is retained in non-volatile memory during power interruptions. The GDA-400 front panel is shown in Figure 2.0 displaying the bar graph data screen. The five button symbols below the display are magnetically activated using the supplied magnetic wand without opening the enclosure. Opening the enclosure door provides access to the “touch” keypad as shown in Figure 2.1.

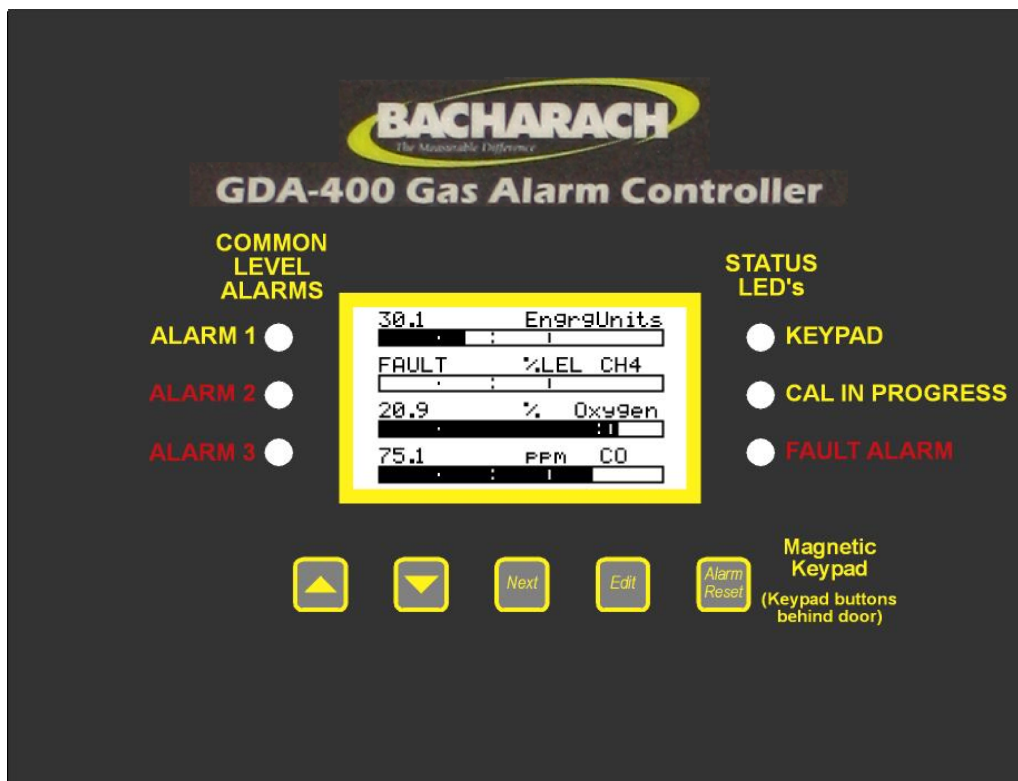

Figure 2.0 - Front Panel

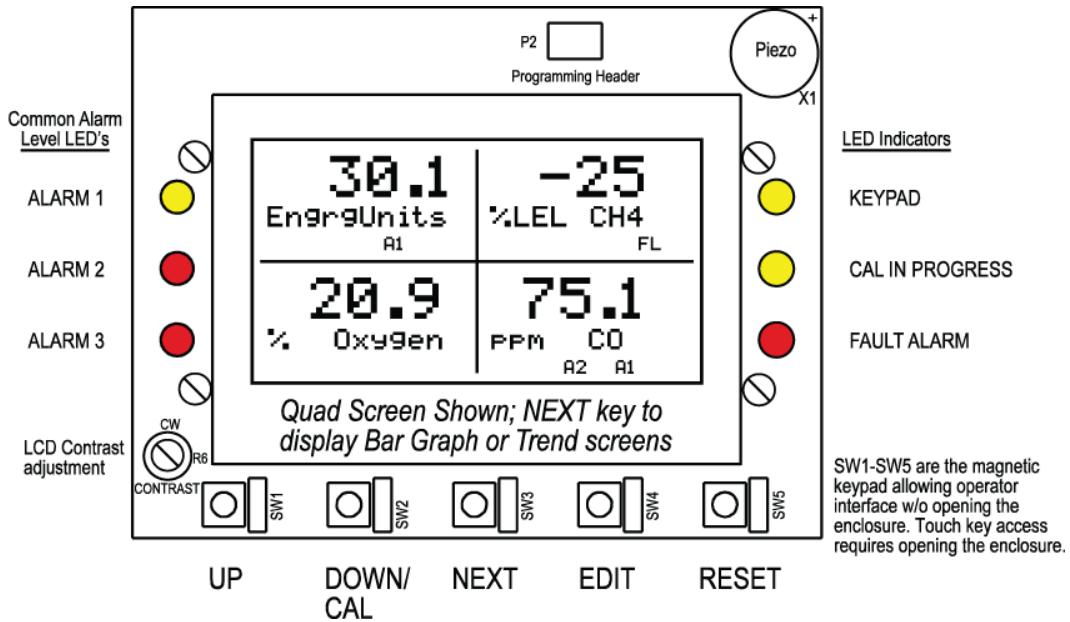

Figure 2.1 – Touch Keypad

2.1 Data Display Screens

The GDA-400 Controller offers three modes for displaying monitored data. Each is shown in Figure 2.2.

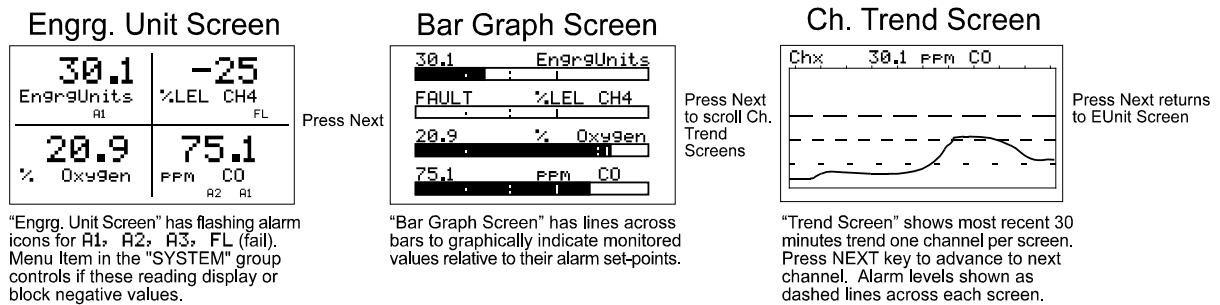

Figure 2.2 – Engineering Unit Screen

2.1.1 Engineering Unit Screen

The GDA-400 *Engineering Unit* screen shown in Figure 2.2 allows each channel’s value and its 10-digit Eunits tag to be viewed simultaneously. **A1**, **A2**, **A3**, and **FL** icons at the lower right of each reading flash if ALARM 1, 2, 3 or FAULT alarms have activated for this channel.

2.1.2 Bar Graph Screen

Values are displayed graphically as bar graphs with alarm levels indicated by vertical dashed lines across each bar. The bar graph screen is useful for emphasizing current reading relative to the channel’s alarm set-point. Live readings and their Eunits appear above each bar graph.

2.1.3 Trend Screen

The GDA-400 also provides 30-minute trend screens for each channel as shown in Figure 1.2. Live readings and their Eunits are displayed across the top of each trend screen. Channel numbers are shown in the upper right and are selected by the NEXT key. A1, A2, and A3 alarm levels appear as horizontal dashed lines across the screen.

2.2 Specifications

2.2.1 Power Supply Requirements

The GDA-400's primary power may be either 10-30 VDC or 100-240VAC. All models are equipped with an integral AC input / 24 VDC 15 watt output switching power supply. AC power requirements are 100-240 VAC, 50/60 Hz @ 0.45 amp max (including inrush) and 20 watt maximum steady state, applied to TB5 on the motherboard. If AC power is not available the primary power may be 10-30 VDC applied to TB1 on the motherboard. A back-up DC power source may also be connected to TB1 for automatic switchover if the AC power source fails. See Figures 4.0 and 4.1 for wiring information.

The basic GDA-400 consumes only 1.5 watts of 10-30 VDC power. Optional features such as relays and analog outputs increase power consumption as described below:

- P/N 5700-0014 - Analog Input PCB option; add wattage for each monitor connected to this board's 24 VDC terminals.
- P/N 5700-0015 - Discrete Relay PCB option; add 1.5 watt.
- P/N 5700-0019 - 4-20mA Output PCB option; add 1 watt.
- P/N 5700-0020 - Bridge Sensor Input PCB option; add wattage of each sensor attached.

With an AC primary power source connected to TB1 on the motherboard, TB3 terminals 1 and 2 on the motherboard provide a maximum of 12 watts output for powering auxiliary external devices such as relays, lights and monitors (see Figure 4.0). Power consumed from TB3 must be included when calculating system power consumption.

IMPORTANT! *TB3 only provides 24VDC power when AC is primary power.*

24 VDC terminals on the Analog input option (P/N 5700-0014) may also be used to power external transmitters and these loads must also be calculated into the overall power budget. These terminals receive power from both the integral AC / DC power supply and the external TB1 supply as shown in Figure 4.0.

Some applications may require 24VDC power in excess of that which is available from the GDA-400's integral AC power supply and thereby require an external AC/DC supply. NEC Class 2, 50 watt external supplies are available for Division 1 and Division 2 potentially hazardous area installations and both also include a NEMA 4X weather rating.

2.2.2 Relays

Two mechanical (dry contact) common Form C relays are standard and may be mapped to various alarm events as described in section 3.3.1. GDA-400's may also be equipped

with optional solid-state common Form A relays for applications requiring non-arcing switching. Solid-state relays are recommended for switching of highly inductive loads.

A six mechanical (dry contact) Discrete Relay option board (see section 4.1.4) provides dedicated Form C relays for ALARM 1, ALARM 2 and FAULT for both channels.

All mechanical (dry contact) relays are rated at 5 Amp for 28 VDC and 250 VAC **RESISTIVE** loads.



IMPORTANT: *Appropriate diode (DC loads) or MOV (AC loads) snubber devices must be installed with inductive loads to prevent RFI noise spikes.*

Optional solid state relays are rated at 2 Amp 12-280 VAC (600Vpk).

Relay wiring should be kept separate from low level signal wiring.

2.2.3 Ambient Temperature Range

-25 to 50 degrees C

2.2.4 Humidity Range

0 to 90% R. H. Non-Condensing.

2.2.5 Altitude

Recommended up to 2000 meters

2.2.6 Housings / Installation Categories

- *NEMA 4X wall mount for DIV 2 Groups A,B,C,D; Category II and pollution degree 3; NEMA 4X; IP66
- *NEMA 7 wall mount for DIV 1 and 2 Groups B,C,D; includes 'O' Ring in door to satisfy NEMA 4 rating.

*Includes standard non-intrusive magnetic keypad.

2.2.7 Approvals

- CSA C22.2 No 1010.1 and ISA S82.02
- CSA C22.2 No 152 for combustibles
- UL 1604 / C22.2 No 213 (Div 2 Groups A,B,C,D)
- EN55011 and EN61000 (CE Mark)
- CSA File # = 219995 and may be seen at: CSA-International.org.

2.3 Accessories

| Part Number | Description |
|-------------|------------------------------------------------|
| 5700-0014 | Quad 4-20mA input card |
| 5700-0020 | Quad bridge sensor input card |
| 5700-0015 | Alarm relay output card |
| 5700-0019 | Quad 4-20mA output card |
| 5700-0017 | RS-232 / RS-485 Modbus RTU output card |
| 5700-0029 | 50 Watt Power Supply |
| 5700-0030 | 120 Watt Power Supply |
| 5700-0032 | 900MHz wireless kit w/dipole antenna |
| 5700-0033 | 2.4GHz wireless kit w/collinear antenna |
| 5700-0040 | 900MHz antenna base station, collinear |
| 5700-0041 | 2.4GHz antenna base station, collinear |
| 5700-0042 | 900MHz antenna, dipole |
| 5700-0043 | 2.4GHz antenna, collinear |
| 5700-0044 | 900MHz antenna, Yagi |
| 5700-0045 | 2.4GHz antenna, Yagi |
| 5700-0046 | Antenna lightning protector |
| 5700-0047 | "N"-to-"RP-SMA" connector adapter |
| 5700-0048 | 15ft. LMR-195 N-type male to RP-SMA male cable |
| 5700-0049 | 75ft. RP-TNC low-loss coax antenna cable |
| 5700-0050 | 50ft. RP-TNC low-loss coax antenna cable |
| 5700-0051 | 25ft. RP-TNC low-loss coax antenna cable |
| 5700-0052 | 15ft. RP-TNC low-loss coax antenna cable |

3 Basic Operation

The GDA-400's graphic LCD displays monitored data which in combination with the 5-button keypad serves as the system's operator interface. All GDA-400 configuration variables are entered with this operator interface using SETUP menus accessed by pressing EDIT from either data screen. This *Setup* mode may be exited manually by pressing NEXT, or automatically when no keys are pressed for 5 minutes. Alarm relays and front panel alarm LED indicators remain active during the *Setup* mode. Alarm LED's flash upon new alarms and become steady after *Acknowledged* by pressing the ALARM RESET key. A SECURITY menu offers a password feature to prevent tampering with GDA-400 parameters.

A "sign-on" screen appears briefly after power is applied that indicates what type input / output options the unit is configured with.

3.1 Setup Menu Configuration

Variables inside the CHANNEL (see section 3.2) and SYSTEM (see section 3.3) menu trees allow the GDA-400 to be configured for a wide range of monitoring applications. Select the desired menu by scrolling with UP/DOWN and then EDIT to enter each menu. Figure 3.0 illustrates the menu tree for configuring *Channel* and *System* specific variables. *Channel* variables affect only the specific channel selected, while *System* variables are related to features not specific to any channel.

3.2 Changing Menu Variables Using the Keypad

Upon entering a menu, a pointer controlled by the UP/DOWN keys indicates the selected variable. Some are simple YES/NO or ON/OFF entries toggled by pressing the EDIT key. Others, such as *Channel ID* and *Eunits* fields may have many ASCII character possibilities. Allowed ASCII characters are ordered as follows:

ABCDEFGHIJKLMNOPQRSTUVWXYZ[\]^_`abcdefghijklmnopqrstuvwxyz blank
space !"#%&`()*+,-./0123456789:;<=>?@.

Notice the often used *blank* character is located after lower case "z" and before the exclamation point "!".

EDIT places a cursor under the item and UP/DOWN scrolls through each allowed entry. The NEXT key moves the cursor to the next position within a field. When the field is complete, EDIT clears the cursor and loads the field into non-volatile memory where it is retained indefinitely. Without a cursor present, the NEXT key closes any open menus in reverse order and returns the LCD to the data display.

QUAD Channel Controller Menu Tree

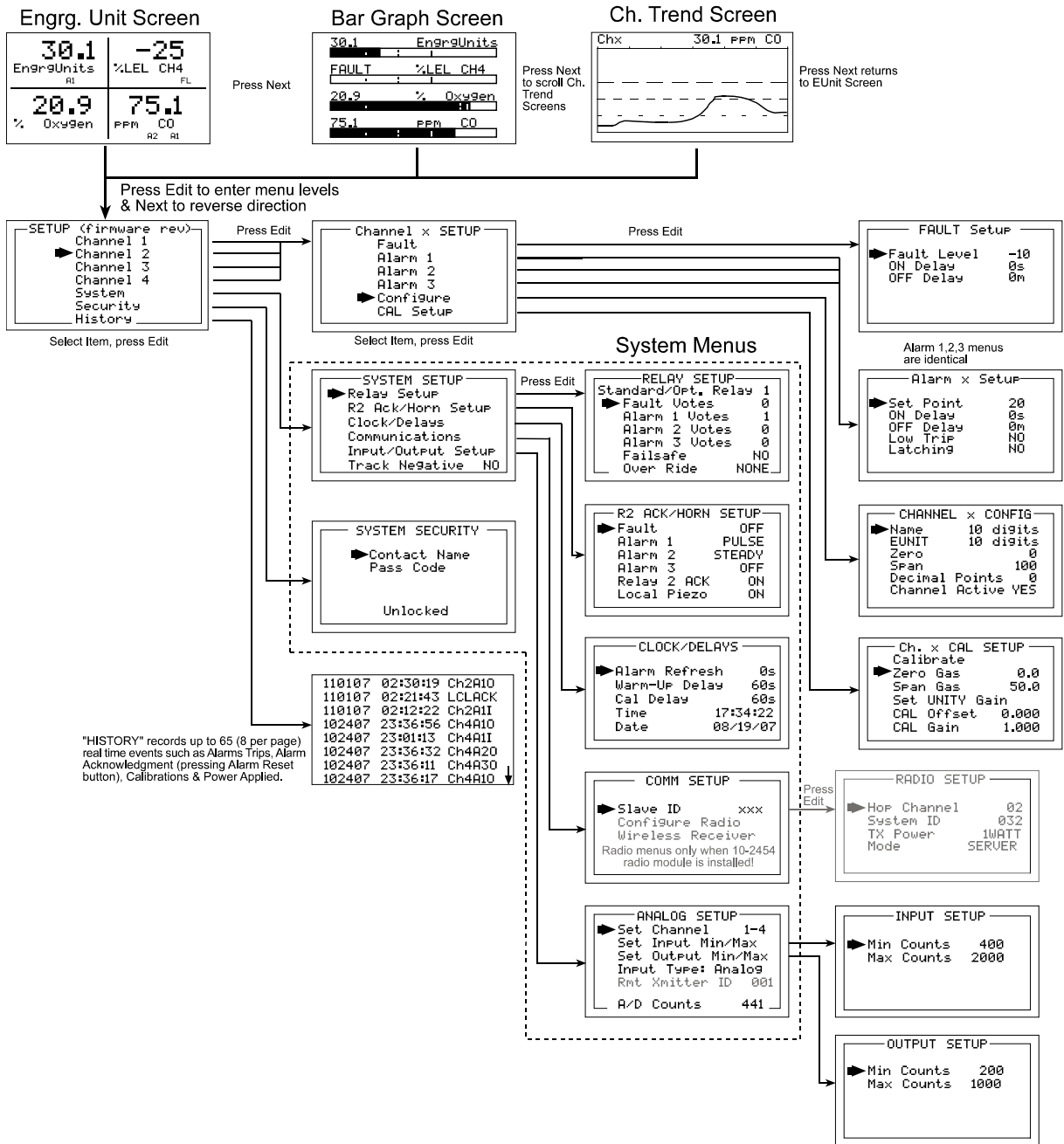

Figure 3.0 – Configuration Menus

3.2.1 GDA-400 Setup Configuration Menus

The SETUP menu shown in the middle of Figure 3.0 and in Figure 3.1 is reached by pressing **EDIT** with any data display present. This is the entry-level screen to ALL *Channel*, *System* and *Security* menus. It also shows the revision of firmware operating in the GDA-400. Use the **UP/DOWN** keys to move the pointer to the desired menu and press the **EDIT** key.

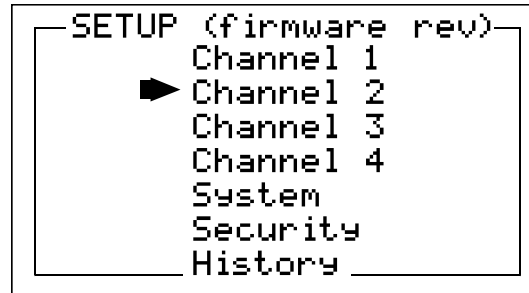

Figure 3.1 – Setup Menu

3.2.2 Channel Setup Entry Menu

The CHANNEL menu shown below in Figure 3.2 allows configuration of all variables for the selected channel. These are **Fault**, **Alarm 1**, **Alarm 2**, **Alarm 3**, **Configure** and **CAL Setup**.

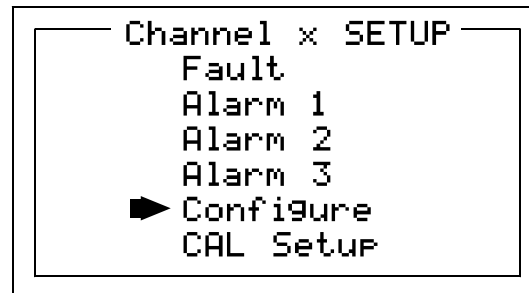

Figure 3.2 – Channel Menu

3.2.3 Fault / Alarm 1 / Alarm 2 / Alarm 3 Set-up Menus

Alarms 1, 2 and 3 have identical menus. The only difference between each is A1 front panel LED indicators are yellow while A2 and A3 are red. Typical applications often have A1 set at a WARN level, A2 at a HIGH level and A3 at a higher SHUT DOWN level. However, it is important to understand that there is no functional difference between A1, A2 and A3 and since their configuration menus are identical, therefore only one is shown in Figure 3.3. The Fault menus are identical to A1, A2, A3 except Fault alarms are always low trips (alarm activates as input goes below the set point) and Fault alarms may not be set for latching operation.

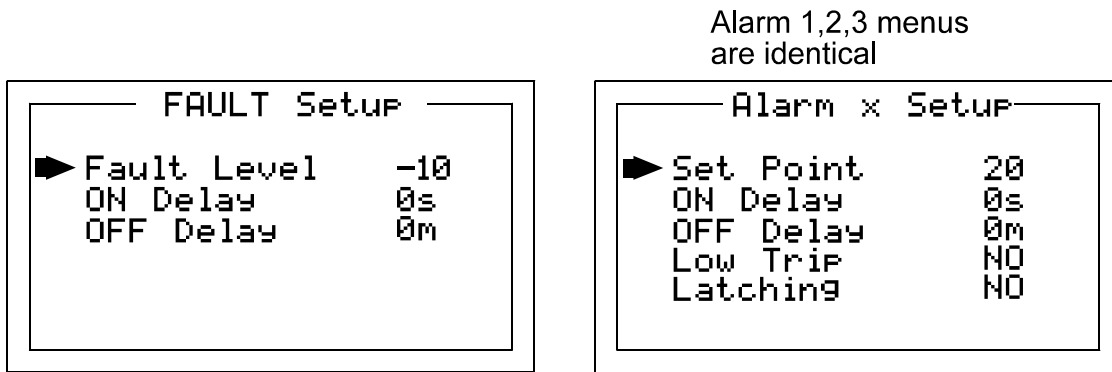

Figure 3.3 – Alarm and Fault Menus

- **Set Point** is entered in engineering units and determines the value in which the alarm trips. For example, if a channel monitors 0-50 ppm H₂S and the desired alarm level is 10 ppm, the correct entry is 10.00. A one percent dead band prevents alarm chatter. This means after tripping an alarm the input must move at least 1% of full scale back through the setpoint for the alarm to auto reset.
- The **ON Delay / OFF Delay** entries allow **ON** and **OFF** time delays to affect how long the trip-point must be surpassed before an alarm event transition occurs. **ON** delays are limited to 10 seconds while **OFF** delays may be as long as 120 minutes. Delays are useful in many applications to prevent nuisance alarms and unwanted cycling into and out of alarm conditions.
- **Low Trip** is set for **NO** for increasing alarms or **YES** for decreasing alarms to determine if the alarm activates upon exceeding or falling below the set-point.
- **Latching** determines either manual or automatic alarm reset operation. **YES** requires a manual **Alarm Reset** to unlatch the alarm even though an alarm condition no longer exists. **YES** also causes this alarm's common relay, front panel LED, and optional discrete relay to latch. **NO** allows all outputs for this alarm to automatically reset after the alarm condition clears.

Common alarm LED indicators on the left side of the front panel indicate the status of A1, A2 and A3 alarms. The common Fault LED is on the lower right side of the front panel. Any *new* alarm event causes the associated LED to flash until an **Alarm Reset** occurs causing an *acknowledged* steady on condition. Operators should recognize *new* alarms by a flashing LED. **Alarm Reset** also *acknowledges*, or deactivates, audible devices driven by the AUDIBLE ALARM option connector J2 (see Figure 4.1).

3.2.4 Configure Menu to Define Channel

The channel setup menu proceeding after the alarm menus is **CONFIGURE**. It allows setting **Name** and **EUNIT** 10 digit ASCII fields, defines the measurement range with **ZERO** and **SPAN** entries, number of **Decimal Points** of resolution the reading will have, and whether or not the channel is **Active**.

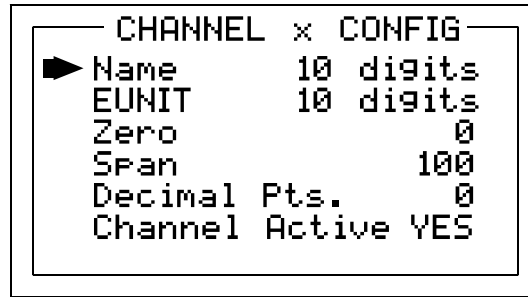

Figure 3.4 – Channel / Configure Menu

3.2.4.1 Name / EUnits ASCII Data Fields

The first two items in this menu are for entering the 10 character channel *Name* and *engineering unit* ASCII fields. *Name* should describe the channel's data in user terminology such as tag number or other description. *Eunits* should define the units of measure for what this channel is to display. Section 3.2 describes how to modify these fields using the keypad.

3.2.4.2 Input Measurement Range

The **Zero / Span** menu entries allow configuration of the measurement range displayed by this channel. Measurement Range defines the range of the input signal's engineering units. For example, if a channel's input is 4-20mA from a transmitter monitoring 0 to 10ppm chlorine, then the **Zero** value should equal 0.000 and the **Span** value equal 10.00. Four digits must be entered so trailing 0's may appear here that are not displayed on other data screens. These menus work hand in hand with Min/Max Raw Counts menus described in section 3.3.4.

3.2.4.3 Decimal Point Resolution

Resolution of the displayed channel value is configured in this menu by setting the number of digits trailing the decimal point. Displayed readings are limited to a maximum of four digits with a polarity sign. Auto-ranging displays the highest resolution allowed by this menu's decimal point entry. For example, a range of 0 to 100ppm and two decimal points reads **0.00** at 0ppm and **100.0** at 100ppm. This may be undesirable due to the high resolution at zero unless the sensor's output is extremely stable. If decimal points are limited to one, the 0ppm reading becomes **0.0** and the 100ppm reading remains **100.0**. Resolution may be limited further by setting decimal points to 0 where in the above example, 0ppm reads **0** and 100ppm reads **100**.

3.2.4.4 Turning Off Unused Channels

The **Channel Active** menu entry asks if this channel is to be utilized. **OFF** causes the controller to never process inputs applied to this channel and no alarms are tripped or data displayed. Inactive channels have a line drawn through them on the Setup screen to indicate it is turned off.

3.2.5 CAL Setup Menu

The GDA-400 CAL MODE feature supports pushbutton calibration of zero and span values. This feature should be utilized only when there are no other zero/span controls within the monitoring system since it is inappropriate to calibrate a signal at more than one point. Therefore, if calibration will be performed at another transmitter or monitoring device, the GDA-400 CAL MODE feature should not be used.

The **CAL SETUP** menu allows for entering of the correct **Zero and Span Gas** set-point values needed to calibrate the channel. These are entered in the same engineering units as input range.

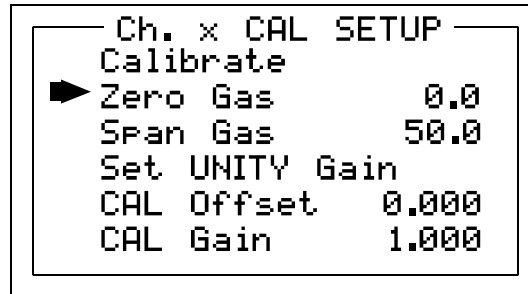

Figure 3.5 – CAL Setup Menu

3.2.6 Calibrate Input Menu

The CAL MODE (flow chart shown in Figure 3.6) is designed to make calibration quick, easy and error free. Optional 4-20mA outputs (if equipped) transmit 1.5mA during CAL MODE and 4mA during the subsequent CAL DELAY to prevent external alarms during calibration. Local GDA-400 alarm relays are inhibited during CAL MODE.

Unintentional calibrations may be reset by the **Set UNITY** menu item. **Set UNITY** resets **Cal OFFSET** to 0 and **Cal GAIN** to 1 which is useful for returning the calibration to a known starting place. Sensor aging may be monitored by recording zero and span readings at **Unity Gain** when the sensor is new, and again later when degradation may have occurred. CAL MODE automatically exits if no keystroke is detected after 5 minutes.

Use the following step-by-step procedure to perform ZERO and SPAN calibrations.

1. To enter the CAL MODE from any data display, press the dual purpose DOWN / CAL key. Use the UP/DOWN keys to select the channel to calibrate.
2. Stimulate the monitor to be calibrated with an appropriate ZERO calibration standard. Observe the screen's live reading and when it is stable press the EDIT key to perform the ZERO calibration.
3. If the ZERO calibration is successful, CAL MODE automatically proceeds to the SPAN check.
4. Apply the correct SPAN calibration standard. After the reading is stable, press the EDIT key to perform a SPAN calibration.



WARNING: The SPAN calibration standard used must match the value specified since this is the reading the GDA-400 will indicate after a successful SPAN calibration. The SPAN calibration value may be edited if it becomes necessary to apply a different calibration standard to set SPAN (see *Span Calibration* in section 3.2.5).

5. If the SPAN calibration is successful, the display flashes “REMOVE CAL GAS” and starts the CAL DELAY.
6. CAL MODE will be complete after the end of the CAL DELAY.

The flow chart in Figure 3.6 illustrates the above procedure. **UP**, **CAL**, **NEXT** and **EDIT** labels indicate keystrokes (**CAL/DOWN** is a dual purpose key). The CAL MODE information screen (top of the chart) is available for advanced users to see Offset / Gain calibration constants and live analog to digital converter (A/D) counts. Span set point calibration values may also be edited from this screen. Holding the **UP** key, for 5 seconds during CAL MODE, displays this screen.

Unity Gain may be used at anytime to cancel incorrect calibrations and start again. Unity means Offset = 0.00 and Gain = 1.00.

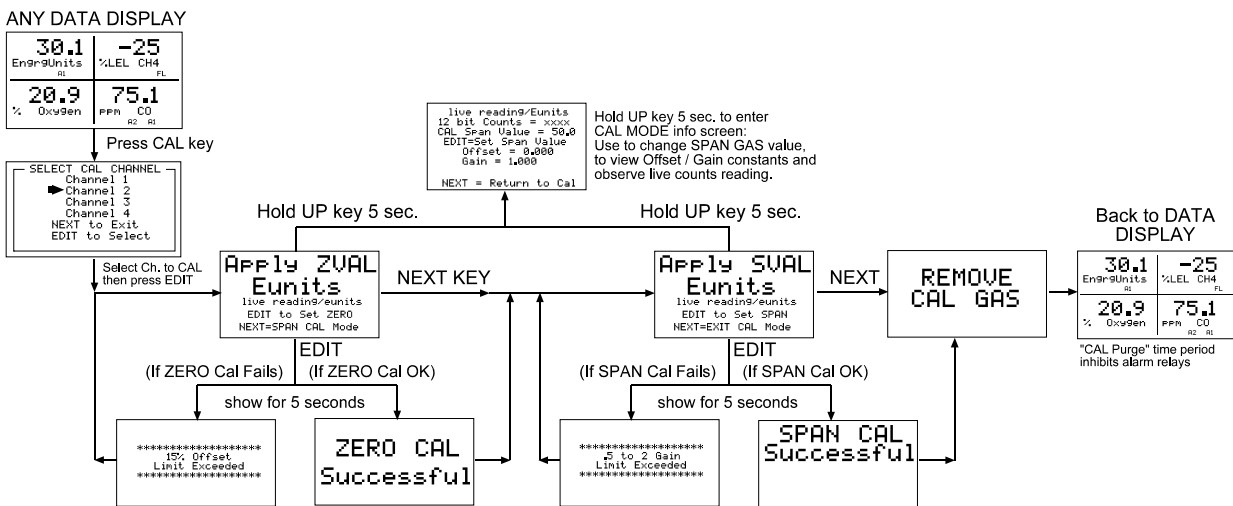

Figure 3.6 – Calibration Procedure Flow Chart

3.3 System Configuration Menus

Several items needing configuration are not specific to either channel but affect the entire GDA-400 system. These are located in the *SYSTEM* menus group shown in the dotted line box in Figure 3.0. System menus are accessed through the System SETUP menu shown in Figure 3.7 by pointing to the desired item and pressing **EDIT**.

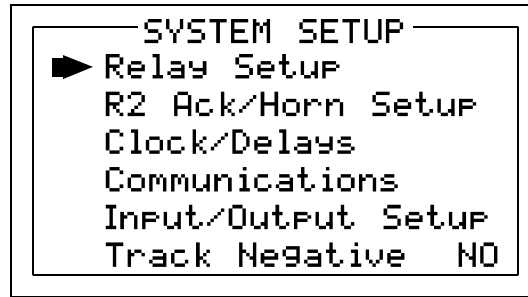

Figure 3.7 – System Setup Menu

3.3.1 Standard / Optional Relay Setup Menus

The menu shown in Figure 3.8 allows for configuring of both the standard **Relay 1** and **Relay 2** motherboard relays and the six optional relays on the discrete relay option PCB (P/N 5700-0015). Both standard and optional relays are programmed in this menu. Select the relay to be configured by pointing the arrow at the top menu item and pressing EDIT. The field will scroll through all eight possible relays (2 standard and 6 optional).



Figure 3.8 – Relay Setup Menu

- **Fault, Alarm 1, Alarm 2, Alarm 3** menus in Figure 3.8 offer additional “voting” flexibility by controlling the channel alarm combinations that will trip the selected relay. Each *Votes* entry requires this quantity of channels, for each type alarm, be active before this relay is activated. As illustrated in Figure 3.8, Standard Relay 1 activates when any 2 channels have Alarm 1 conditions, while in addition, any one channel has an Alarm 2 condition. And since the **Over Ride** menu (see description below) contains the **Ch1A2** entry Standard Relay 1 also activates if alarm 2 on channel 1 trips. Fault Votes and Alarm 3 Votes values are 0, therefore Fault and Alarm 3 conditions will not affect this relay. Votes follow the logical “AND” function.
- **Failsafe** (Default set for YES) causes this relay to be energized when its voting requirements are false (no alarm condition) and de-energized when the alarm vote requirements are true. The primary benefit of **Failsafe** is loss of power places the relay contacts into the alarm condition.
- **“Over Ride”** menu allows for entering of one of the 16 different alarms that will trip this relay regardless of the *Votes* entries. There are four channels with four alarms per channel, and any one of these alarms may be used as the Over Ride. This feature is useful when one channel’s alarm has more significance than the others.

3.3.2 Relay 2 ACK (Acknowledge) / Horn Setup Menu

- The **Horn SETUP** menu controls how each alarm type (Fault, and Alarms 1 through 3) will affect the horn driver circuit connected to J2 on the motherboard. Choices are **OFF**, **STEADY** or **PULSE**. Warning level alarms might be set to pulse the horn with high alarms set for steady. Personnel then know which alarm level is present by hearing the pulsing or steady horn.
- **Relay 2 Acknowledge** (Default set to **ON**) allows Relay 2 to be deactivated during alarm conditions by an **Alarm Reset**. This is useful if another audible device is being driven by the relay. The acknowledge feature is not available for Relay 1 since it is often used for driving a warning light and Relay 2 for driving a horn. It could be dangerous if an operator acknowledged the horn AND the light since no indication of the high alarm condition remains.
- **Local Piezo** (Default set to **ON**) causes the tiny local piezo adjacent to the LCD to mimic the J2 horn output.

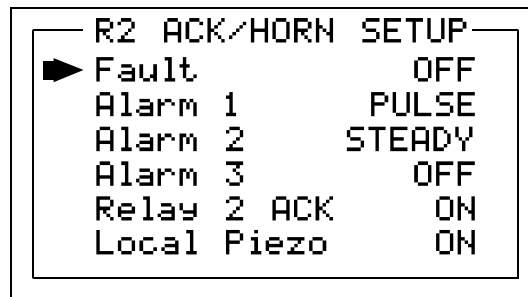

Figure 3.9 – Acknowledge / Horn Setup Menu

3.3.3 Clock / Delays Menu

These GDA-400 timers accommodate inputs that may require varying times to stabilize after power is applied and after calibrations are complete.

- **Alarm Refresh** menu allows reactivation of *Acknowledged* alarms after the time period expires. This feature is used primarily to restart audible alarm devices after having been silenced by an acknowledge function (via serial port or pressing the Alarm Reset button). An entry of 0 seconds effectively disables the **Alarm Refresh** function.
- **Warm-Up Delay** menu allows for setting how long alarm relays remain disabled after power is applied.
- **Cal Delay** determines how long alarm relays are inhibited after completing a calibration.
- **Time** and **Date** menu items are for setting the correct time and date. The GDA-400 is equipped with a 24-hour clock and calendar. Time of day must be entered in 24 hour mode. For example, 6:00:00 PM = is indicated as 18:00:00.

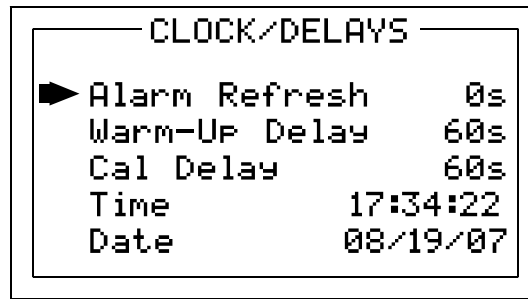

Figure 3.10 – Clock / Delays Menu

3.3.4 Communications Menu

The **COMM SETUP** menu allows setting of the system's modbus **Slave ID** or RTU address (requires Modbus option PCB – see Section 3.2). This *slave* port may be used to transfer GDA-400 data to a modbus *master* device such as a PC, PLC, DCS or even other Bacharach, Inc. Controllers such as the 16 Channel ST-71. The slave port is addressable, allowing many GDA-400 controllers to be connected to a single RS-485 cable. A converter is available to make this port also compatible with Ethernet TCP/IP networks.

The entire modbus database, including registers and supported Function Codes, is documented in Section 4.3.1. See Section 4 for **COMM SETUP** menu descriptions for **WIRELESS** GDA-400 networks.

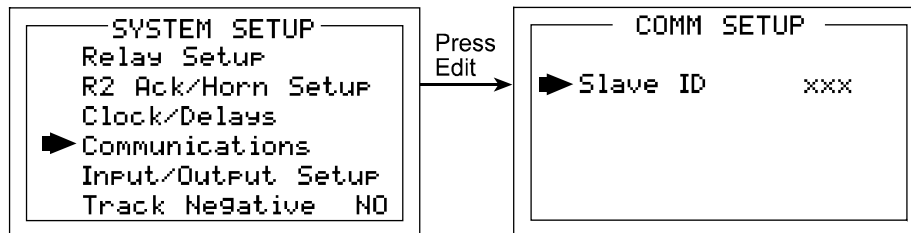

Figure 3.11 – Communications Menu

3.3.5 Analog Setup Menu

The systems **ANALOG SETUP** menus in Figure 3.12 allow for setting of the 11-bit A/D (analog to digital) counts and the 10-bit D/A (digital to analog) counts for each of the four channels. Use the **Set Channel** entry to scroll to the desired channel using the EDIT key. The live A/D counts value for the channel selected is also shown on the bottom of this screen.

The default setting for A/D counts is 400 for minimum and 2000 for maximum. This is based on a 0-20mA input providing 0-2000 counts, or, 100 counts per mA input.

- **Min Counts / Max Counts** entries in the **INPUT SETUP** menus define the input A/D counts range for **Zero** and **Span** readings as described in section 3.2.4.1. The default settings for each analog channel are 400 to 2000 counts. Standard inputs yield 400 counts at 4mA and 2000 counts at 20mA but, for example, if a special application requires the **Zero** reading at 6mA input and the **Span** reading at 18mA input the correct **A/D Min / Max Raw** counts would be 600 to 1800.00.

- **Min Counts / Max Counts** entries in the **OUTPUT SETUP** menus define the output D/A counts range for **Zero** and **Span** readings as described in section 2.2.4.1. **OUTPUT SETUP** menus are only used when the GDA-400 is equipped with the 5700-0019 4-20mA output option (Section 4.2). Ideally, 200 to 1000 yields a 4-20mA output but slight modifications may be needed to provide precise 4mA and 20mA values for each channel.

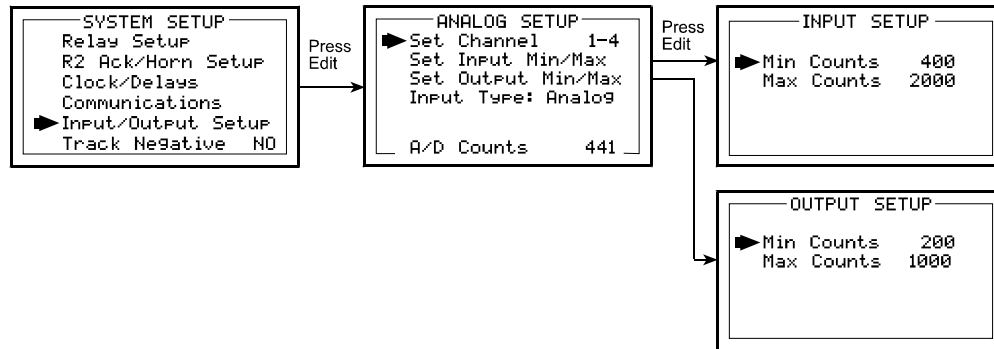

Figure 3.12 – Analog Setup Menus

3.4 System Security Menu

A 4-digit **Pass Code** entered and confirmed in this menu item locks all menus. *Viewing* menus is not denied but attempts to *edit* variables flashes the **Locked** message on the LCD.

Authorized individuals locking the system should first enter a name, phone #, or other contact information into the 12 character field on the top line of the Security screen. To lock or unlock the system the correct 4 digit authorization number must be entered into the **Pass Code** field. It is very important to remember the 4 digit code since the factory must be consulted if it is lost.

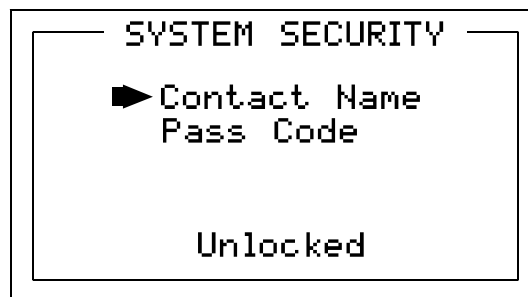

Figure 3.13 – System Security Menu

4 Display to Device Connections

4.1 Motherboard Interface PCB

The GDA-400 Motherboard shown below in Figure 4.1 is the interface between the Display / CPU assembly and all other system I/O devices. The Display / CPU assembly attaches to the motherboard with 4-standoffs and connects via ribbon cable to S1. Input options described in sections 4.1.1 and 4.1.2 are available that may be installed into the *Input Option* P1 connector located on the lower left side of the motherboard. The middle position P2 connector is for the 4-20mA Output option (P/N 5700-0019) and the right position P3 connector is for the Discrete Relay option (P/N 5700-0015). Other optional devices such as Modbus RTU RS-485, Ethernet and a data logger may also be installed to connectors located on the Motherboard.

The Motherboard PCB contains a 24 VDC universal input (100-240 VAC) switching power supply with up to 350mA available at the TB3 Auxiliary Power Output terminals. If AC power is unavailable, or if a DC battery back-up supply is needed, TB1 provides terminals for DC power input. Blocking diodes isolate internal and external DC supplies as shown in Figure 4.0. See section 2.2.1 for additional power source information.

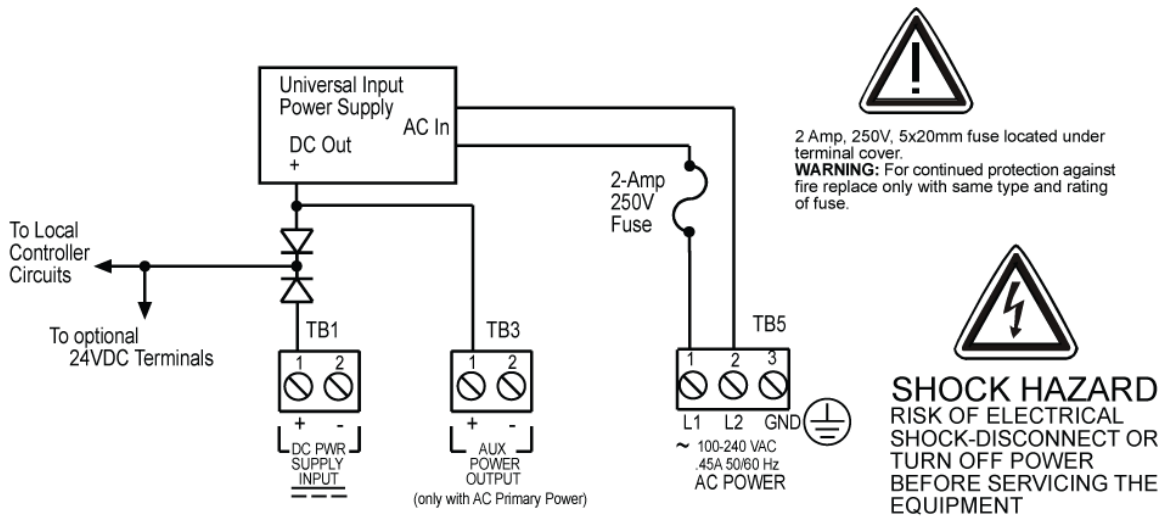

Figure 4.0 – Power Supply Connections

TB2 offers field terminals for a remote alarm reset switch. The motherboard also includes standard alarm relays 1 and 2 (K1 and K2) and their indicating LED's. TB4 provides field wiring terminals for these relays. TB5 is for connection to the 100-240 VAC power source.

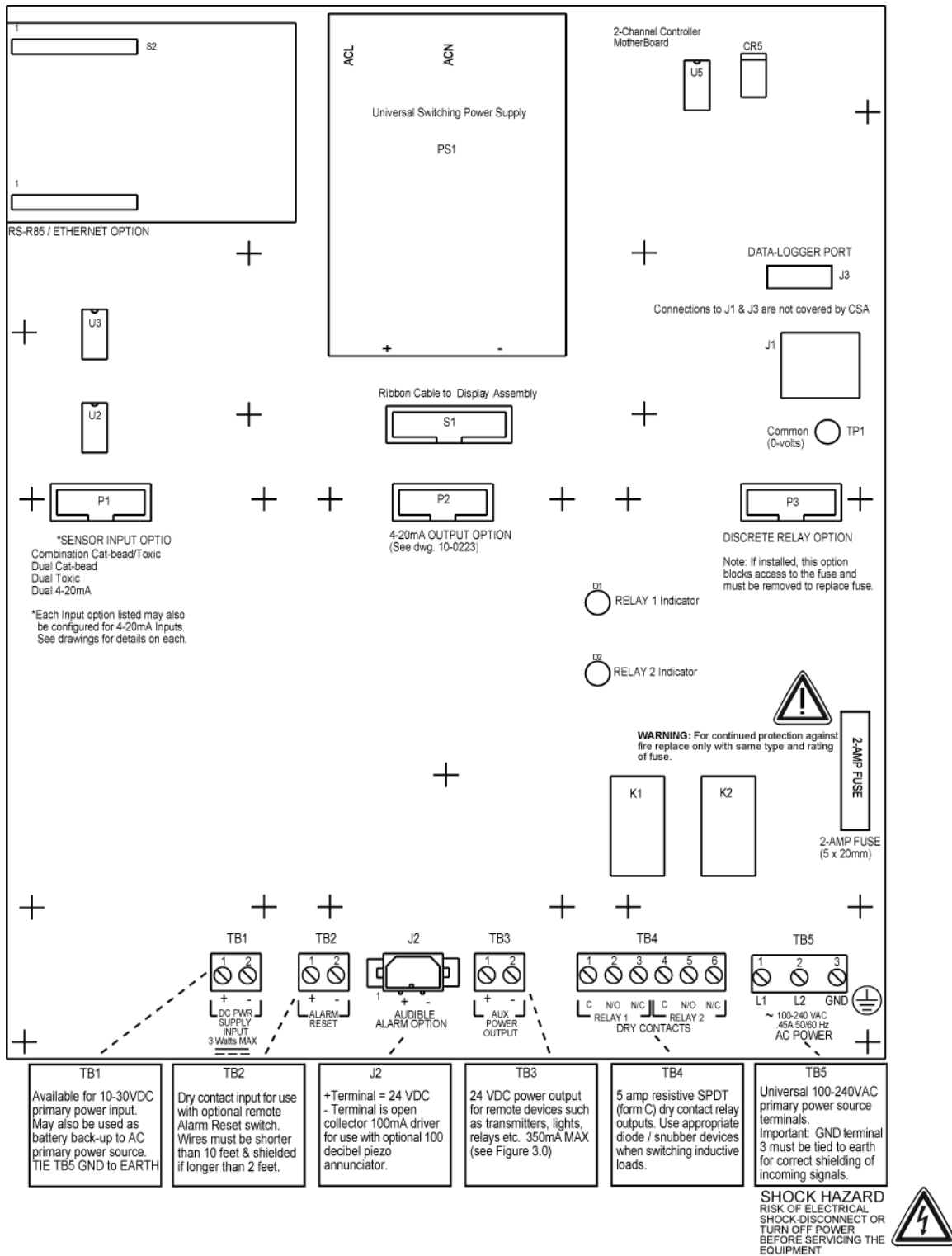

Figure 4.1 - Motherboard

4.2 Input / Output Optional PCBs

P1, P2 and P3 connectors on the motherboard offer unique positions for I/O options described in this section. A screen appears briefly after power-up indicating which I/O options are connected. The P1 position accepts either the 4 Analog Input option (P/N

5700-0014) or the Bridge Sensor Input option (P/N 5700-0020). Both have default **Input Min / Max** menu (see section 3.3.4) settings of 400 – 2000 counts.

P2 is reserved only for the 4-20mA Output option (P/N 5700-0019) and P3 is reserved only for the Discrete Relay option (P/N 5700-0015). Connector locations, relative to each option’s mounting screws, prevent incorrect installation.

4.2.1 Optional Analog Input PCB # 5700-0014

IMPORTANT: *This PCB (P/N 5700-0014) may only be installed into motherboard position P1.*

Analog input PCB option (P/N 5700-0014), shown in Figure 4.2 allows for interfacing GDA-400’s to field transmitters having 4-20mA or voltage outputs. Remove socketed 100 ohm (R1 – R4) terminators for 0-4 VDC max voltage inputs. The 5700-0014 utilizes a 12-bit A/D converter such that 4mA provides 400 counts and 20mA 2000 counts. Min/Max raw count menus default to 400/2000 but may be adjusted between 0/4095 as described in the **A/D Min / Max Raw** discussion in section 3.3.4. TB1 and TB2 provide each channel’s terminals for receiving analog inputs. TB1 and 2 also provides 4 terminals connected to the GDA-400 internal 24 VDC power supply for powering external transmitters. Figure 4.3 shows correct wiring for both 2-wire and 3-wire transmitters.

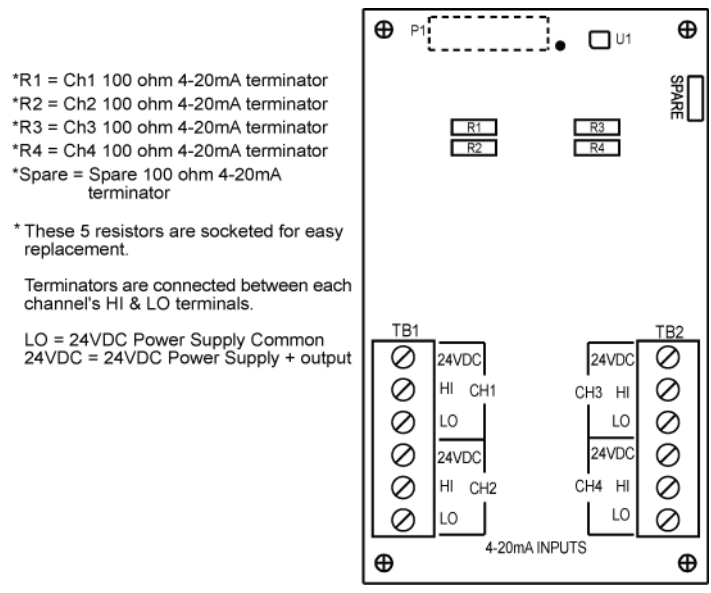

Figure 4.2 – Analog Input PCB Option

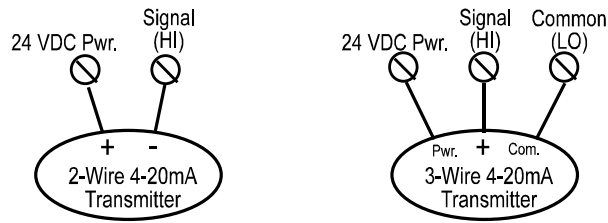

Figure 4.3 – Wiring Schematic

4.2.2 Optional Bridge Sensor Input Board #5700-0020

IMPORTANT: This PCB (P/N 5700-0020) may only be installed into motherboard position P1.

The Quad Channel *Bridge Sensor Input* option (P/N 5700-0020) shown in Figure 4.4 allows these sensors to be connected directly to the GDA-400 without additional signal conditioning or transmitters. Each channel is equipped with a bridge amplifier, balance potentiometer, and an adjustable switching regulator for setting the correct sensor excitation voltage. A 3-position coarse gain jumper allows setting the gain of the bridge amplifier. Fault supervision circuitry forces the GDA-400 into a FAULT condition upon sensor failure or removal.

This option may also be configured to accept 4-20mA inputs into channels 3 and 4 to allow mixing sensors and current loops into the same board. Placing either channel's 2-position LEL/4-20mA jumper (JP5 or JP6) into the 4-20mA position, and installing the associated precision 100 ohm socketed resistor, allows 4-20mA signals to be applied to the mA+ / mA- terminals (see *Optional 4-20mA notes* in Figure 4.4). Precision 100 ohm resistors are taped to the inside of the GDA-400 enclosure.

Bridge sensors require the *Initial Setup* calibration procedure described in section 4.2.3. After performing the one time only *Initial Setup* all subsequent calibrations are by the GDA-400's electronic Cal Mode menus (see section 3.2.5). Sensors mounted locally to the GDA-400 normally do not require *Initial Setup* since it is performed at the factory.

4.2.3 Bridge Sensor Initial Setup

Bridge sensors vary widely in power requirements and sensitivity. It is therefore important to configure each channel to match the sensor with which it will operate.

Sensors attached to the GDA-400 enclosure at the factory have already had *Initial Setup*.

1. Prior to connecting remote sensors, apply power to the system. Measure the voltage between each channel's A and R terminals and set the *Voltage Adjust* potentiometers for the correct sensor excitation voltage (remove GDA-400 terminal cover). This may range from 1.5 volts to 7.5 volts depending upon sensor specifications. **Sensors may be damaged by accidental over voltage conditions. It is recommended the *Voltage Adjust* potentiometer screws be covered by a dollop of RTV or similar material after completion of this procedure.**
2. Remove system power and connect sensor wires to the A-C-R terminals. Reapply system power and confirm correct voltage across each sensor's A and R

terminals. Note if sensor wires are long, it will be necessary to measure the excitation voltage at the sensor end to compensate for IR voltage losses in the wiring.

3. With zero cal stimulus on that sensor, adjust it's *Balance* potentiometer for a ZERO reading on the LCD.
4. Apply 50% span stimulus to the sensor and allow the reading to stabilize. Place the 3-position *Coarse Gain* jumper into the position which reads between approximately 45 and 65% with 50% on the sensor. Gain settings for each jumper position are as follows: no jumpers = 1, **LO** = 7, **MED** = 12, **HI** = 24. Multiple jumpers have an additive affect upon gain, so for example the **LO** and **MED** jumpers together provide a gain of 19.

Initial setup is now complete and normally only requires repeating if a sensor is replaced. **Final calibration of this channel may now be performed using the GDA-400's electronic Cal Mode feature described in section 3.2.5.**

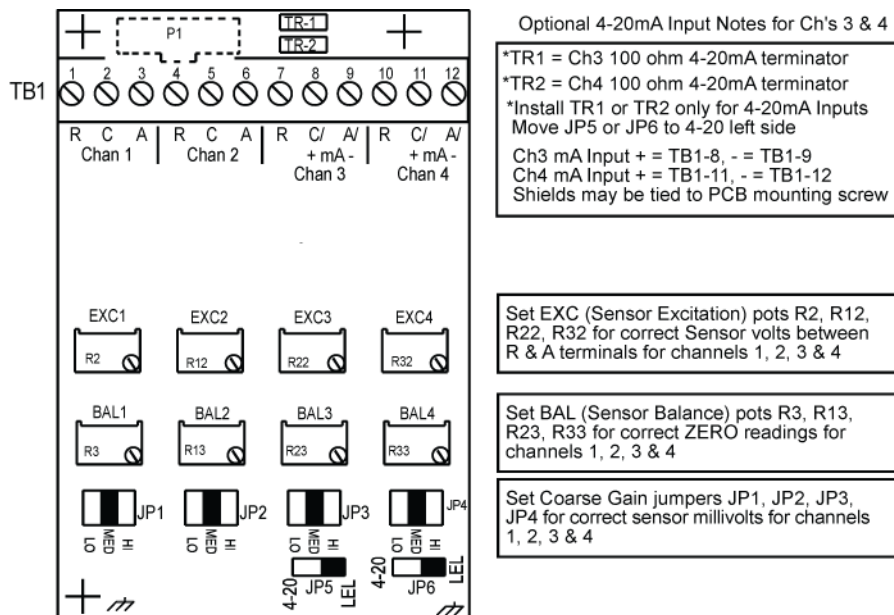

Figure 4.4 – Quad Channel Bridge Sensor Input

4.2.4 Optional Discrete Relay PCBs #5700-0015

IMPORTANT: *This PCB (P/N 5700-0015) may only be installed into motherboard position P3.*

The optional *Discrete Relay PCB*, shown in Figure 4.5, adds six 5-amp form C relays. Each relay is fully programmable as described in section 3.3.1. Many GDA-400 applications utilize the standard equipped Relay 1 / Relay 2 (see section 2.3.1) and do not require optional discrete relays

All mechanical (dry contact) relays are rated at 5 Amp for 28 VDC and 250 VAC **RESISTIVE** loads.



IMPORTANT: Appropriate diode (DC loads) or MOV (AC loads) snubber devices must be installed with inductive loads to prevent RFI noise spikes.

AC or DC power supplies to relays on the Discrete Relay PCB option (P/N 5700-0015) must be the same for each relay. (Example: 24VDC should not be the power switched by one relay and 115VAC by others).

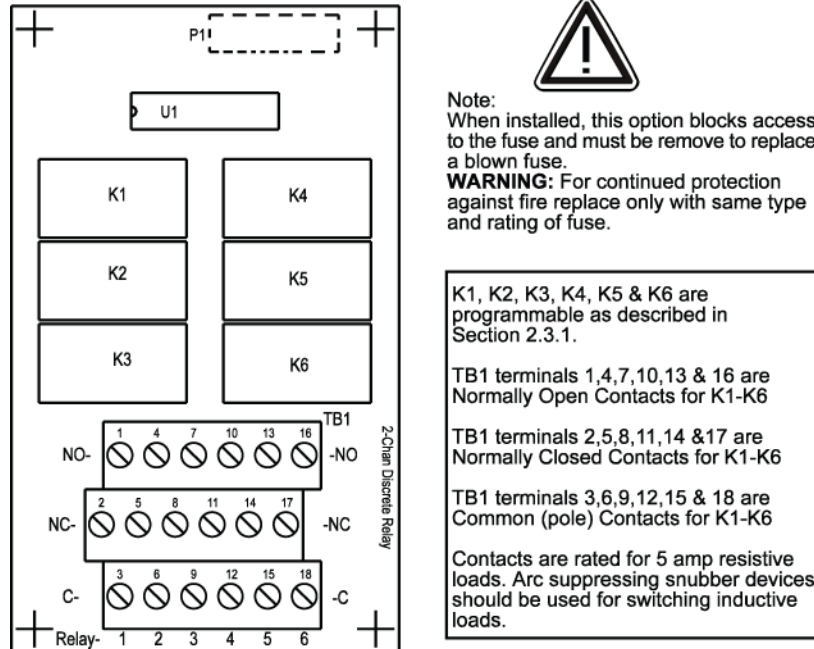

Figure 4.5 – Discrete Relay PCB

4.2.5 Optional 4-20mA Analog Output Board #5700-0019

IMPORTANT: This PCB (P/N 5700-0019) may only be installed into motherboard position P2.

An optional 10-bit 4-20mA analog output board, shown in Figure 4.6, may be added. Each channel's output will transmit 4mA for 0% readings and 20mA for 100% readings. If the GDA-400 primary power is 100 – 240 VAC or at least 24 VDC, 4-20mA outputs are capable of driving 20mA through a 750 ohm load. Outputs are self powered and DC power should not be provided by the receiving device. Precision calibration of the 4-20mA output DAC (digital to analog converter) is accomplished via the **Analog Setup** menu as described in section 3.3.4.

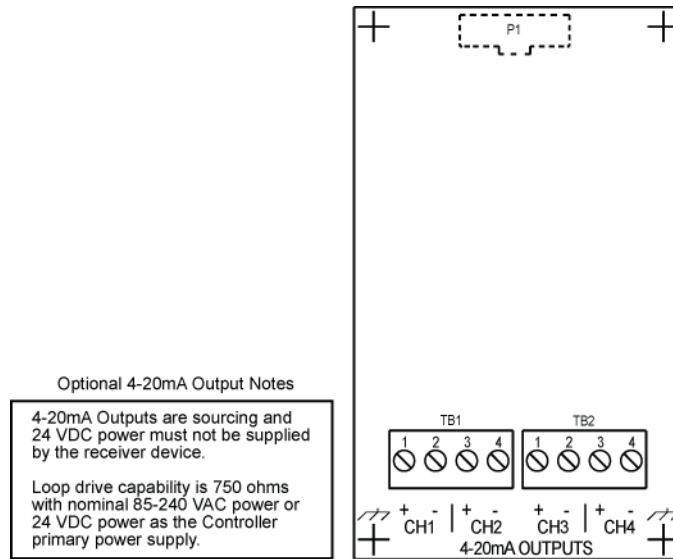

Figure 4.6 – Analog Output Board

4.3 MODBUS RS-232 / RS-485 Interface Option #5700-0017

The Modbus option PCB (P/N 5700-0017) adds both RS-232 and RS-485 Modbus RTU slave ports. Figure 4.7 shows this optional PCB which mounts to connectors on the upper left corner of the GDA-400 motherboard. TB1 provides two pairs of T/Rx terminals and a floating terminal for shield continuation. This makes it easy to multi-drop GDA-400's onto an RS-485 cable without doubling wires into the same screw terminals. RS-232 interface may be made by connecting to DB9 connector S1. Section 4.3.1 lists all modbus registers and their function codes.



Follow correct IEEE RS-232 and RS-485 installation guidelines when using the 5700-0017 option.

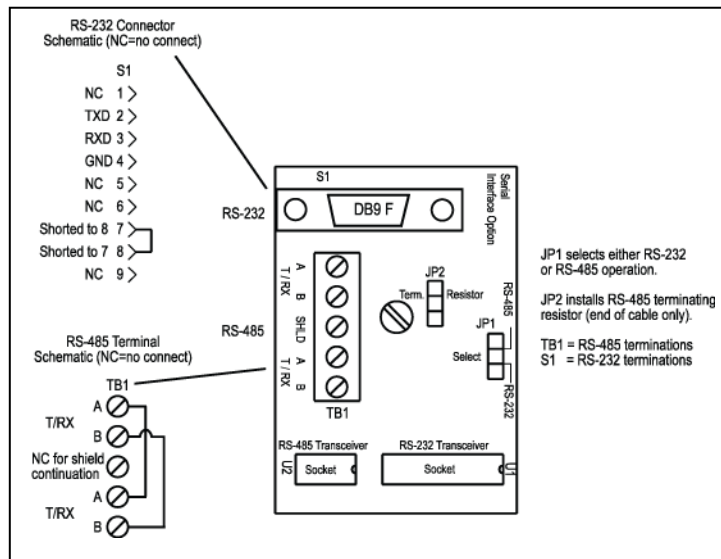

Figure 4.7 – MODBUS PCB

4.3.1 MODBUS Register and Function Code Summary

The following table identifies the available modbus RTU register locations and function codes.

| VARIABLE | ALIAS | READ FUNCTION CODE | WRITE FUNCTION CODE |
|----------|-------|--------------------|---------------------|
|----------|-------|--------------------|---------------------|

Read/Write Coils:

| | | | |
|-----------------|------|---|---|
| Alarm Ack/Reset | 2001 | 1 | 5 |
|-----------------|------|---|---|

Note: After writing a TRUE to this register, the GDA-400 automatically returns it to FALSE.

Read Only Discrete:

| | | | | |
|-------------------|-------------|-------|---|----|
| Chan 1 | Fault Alarm | 12001 | 2 | NA |
| Chan 1 | Alarm 1 | 12002 | 2 | NA |
| Chan 1 | Alarm 2 | 12003 | 2 | NA |
| Chan 1 | Alarm 3 | 12004 | 2 | NA |
| Chan 2 | Fault Alarm | 12005 | 2 | NA |
| Chan 2 | Alarm 1 | 12006 | 2 | NA |
| Chan 2 | Alarm 2 | 12007 | 2 | NA |
| Chan 2 | Alarm 3 | 12008 | 2 | NA |
| Chan 3 | Fault Alarm | 12009 | 2 | NA |
| Chan 3 | Alarm 1 | 12010 | 2 | NA |
| Chan 3 | Alarm 2 | 12011 | 2 | NA |
| Chan 3 | Alarm 3 | 12012 | 2 | NA |
| Chan 4 | Fault Alarm | 12013 | 2 | NA |
| Chan 4 | Alarm 1 | 12014 | 2 | NA |
| Chan 4 | Alarm 2 | 12015 | 2 | NA |
| Chan 4 | Alarm 3 | 12016 | 2 | NA |
| Standard Relay 1 | | 12017 | 2 | NA |
| Standard Relay 2 | | 12018 | 2 | NA |
| Optional Relay 1 | | 12019 | 2 | NA |
| Optional Relay 2 | | 12020 | 2 | NA |
| Optional Relay 3 | | 12021 | 2 | NA |
| Optional Relay 4 | | 12022 | 2 | NA |
| Optional Relay 5 | | 12023 | 2 | NA |
| Optional Relay 6 | | 12024 | 2 | NA |
| Input Fault Relay | | 12025 | 2 | NA |

Read Only Registers:

| | | | |
|------------|-------|---|----|
| Product ID | 30001 | 4 | NA |
|------------|-------|---|----|

Returns the numeric value "1000" for product ID.

| | | | |
|----------------|-------|---|----|
| Firmware value | 30002 | 4 | NA |
|----------------|-------|---|----|

Return a numeric value for firmware value as (Version divided by 100).

| | | | |
|------------|-------|---|----|
| D2A Chan 1 | 31001 | 4 | NA |
| D2A Chan 2 | 31002 | 4 | NA |
| D2A Chan 3 | 31003 | 4 | NA |
| D2A Chan 4 | 31004 | 4 | NA |

12 bit value representing the D2A value of 800 (0%) to 4000(100%) after all cal features are applied.

| | | | |
|---------------|-------|---|----|
| Chan 1 Status | 31005 | 4 | NA |
| Chan 2 Status | 31006 | 4 | NA |
| Chan 3 Status | 31007 | 4 | NA |
| Chan 4 Status | 31008 | 4 | NA |

16 bit status word bit assignment for each channel.

| | |
|----------------------|-------|
| ALARM1_BELOW_BIT | BIT1 |
| ALARM2_BELOW_BIT | BIT2 |
| ALARM3_BELOW_BIT | BIT3 |
| ALARM1_LATCH_BIT | BIT5 |
| ALARM2_LATCH_BIT | BIT6 |
| ALARM3_LATCH_BIT | BIT7 |
| WIRELESS INPUT | BIT4 |
| CHANNEL_DISABLED_BIT | BIT9 |
| CHANNEL_CAL_BIT | BIT10 |

| | | | |
|--------------------|-------|---|----|
| System Status Word | 31009 | 4 | NA |
|--------------------|-------|---|----|

16 bit status word bit assignment for system status.

| | |
|-------------------|-------|
| TRACK NEGATIVE | BIT0 |
| WIRELESS RECEIVER | BIT1 |
| SECURITY LOCK | BIT15 |

| | | | |
|-------------------|-------|---|----|
| Alarm Status Word | 31010 | 4 | NA |
|-------------------|-------|---|----|

16 bit status word bit assignment for system status.

| | |
|--------------|-------|
| CHAN1 FAULT | BIT0 |
| CHAN1 ALARM1 | BIT1 |
| CHAN1 ALARM2 | BIT2 |
| CHAN1 ALARM3 | BIT3 |
| CHAN2 FAULT | BIT4 |
| CHAN2 ALARM1 | BIT5 |
| CHAN2 ALARM2 | BIT6 |
| CHAN2 ALARM3 | BIT7 |
| CHAN3 FAULT | BIT8 |
| CHAN3 ALARM1 | BIT9 |
| CHAN3 ALARM2 | BIT10 |
| CHAN3 ALARM3 | BIT11 |
| CHAN4 FAULT | BIT12 |
| CHAN4 ALARM1 | BIT13 |
| CHAN4 ALARM2 | BIT14 |
| CHAN4 ALARM3 | BIT15 |

| | | | |
|------------------|-------|---|----|
| LED Blink Status | 31011 | 4 | NA |
|------------------|-------|---|----|

Bit set to 1 = LED Blinking, bit set to 0 = LED is steady ON.

| | |
|--------------|-------|
| CHAN1 FAULT | BIT0 |
| CHAN1 ALARM1 | BIT1 |
| CHAN1 ALARM2 | BIT2 |
| CHAN1 ALARM3 | BIT3 |
| CHAN2 FAULT | BIT4 |
| CHAN2 ALARM1 | BIT5 |
| CHAN2 ALARM2 | BIT6 |
| CHAN2 ALARM3 | BIT7 |
| CHAN3 FAULT | BIT8 |
| CHAN3 ALARM1 | BIT9 |
| CHAN3 ALARM2 | BIT10 |
| CHAN3 ALARM3 | BIT11 |

| | | | |
|--------------------------------------|-------|-------|----|
| CHAN4 FAULT | | BIT12 | |
| CHAN4 ALARM1 | | BIT13 | |
| CHAN4 ALARM2 | | BIT14 | |
| CHAN4 ALARM3 | | BIT15 | |
| Relay Status | 31012 | 4 | NA |
| Note: 1 = energized; 0 = deenergized | | | |
| STANDARD RELAY 1 | | BIT0 | |
| STANDARD RELAY 2 | | BIT1 | |
| OPTION RELAY 1 | | BIT2 | |
| OPTION RELAY 2 | | BIT3 | |
| OPTION RELAY 3 | | BIT4 | |
| OPTION RELAY 4 | | BIT5 | |
| OPTION RELAY 5 | | BIT6 | |
| OPTION RELAY 6 | | BIT7 | |
| COMMON FAULT (no relay) | | BIT8 | |
| Reserved | | BIT9 | |
| Reserved | | BIT10 | |
| Reserved | | BIT11 | |
| Reserved | | BIT12 | |
| Reserved | | BIT13 | |
| Reserved | | BIT14 | |
| Reserved | | BIT15 | |

| <u>VARIABLE</u> | <u>ALIAS</u> | <u>READ FUNCTION CODE</u> | <u>WRITE FUNCTION CODE</u> |
|-----------------|--------------|---------------------------|----------------------------|
|-----------------|--------------|---------------------------|----------------------------|

Memory Reals:

Notes: 41001 – 41040 “Real” represents float value without the decimal point such that 123.4 is returned as 1234. Decimal divisor is returned as 1, 10, 100, or 1000 for decimal position of 1, 2, 3, or 4, where 123.4 would return the divisor value 10.

| | | | |
|----------------------------|-------|---|----|
| Chan 1 Zero Real | 41001 | 3 | NA |
| Chan 1 Zero Divisor | 41002 | 3 | NA |
| Chan 1 Span Real | 41003 | 3 | NA |
| Chan 1 Span Divisor | 41004 | 3 | NA |
| Chan 1 Fault Alarm Real | 41005 | 3 | NA |
| Chan 1 Fault Alarm Divisor | 41006 | 3 | NA |
| Chan 1 Alarm 1 Real | 41007 | 3 | NA |
| Chan 1 Alarm 1 Divisor | 41008 | 3 | NA |
| Chan 1 Alarm 2 Real | 41009 | 3 | NA |
| Chan 1 Alarm 2 Divisor | 41010 | 3 | NA |
| Chan 1 Alarm 3 Real | 41011 | 3 | NA |
| Chan 1 Alarm 3 Divisor | 41012 | 3 | NA |
| Chan 2 Zero Real | 41013 | 3 | NA |
| Chan 2 Zero Divisor | 41014 | 3 | NA |
| Chan 2 Span Real | 41015 | 3 | NA |
| Chan 2 Span Divisor | 41016 | 3 | NA |
| Chan 2 Fault Alarm Real | 41017 | 3 | NA |
| Chan 2 Fault Alarm Divisor | 41018 | 3 | NA |
| Chan 2 Alarm 1 Real | 41019 | 3 | NA |
| Chan 2 Alarm 1 Divisor | 41020 | 3 | NA |
| Chan 2 Alarm 2 Real | 41021 | 3 | NA |
| Chan 2 Alarm 2 Divisor | 41022 | 3 | NA |
| Chan 2 Alarm 3 Real | 41023 | 3 | NA |
| Chan 2 Alarm 3 Divisor | 41024 | 3 | NA |

| | | | |
|----------------------------|--------|---|----|
| Chan 3 Zero Real | 410251 | 3 | NA |
| Chan 3 Zero Divisor | 41026 | 3 | NA |
| Chan 3 Span Real | 41027 | 3 | NA |
| Chan 3 Span Divisor | 41028 | 3 | NA |
| Chan 3 Fault Alarm Real | 41029 | 3 | NA |
| Chan 3 Fault Alarm Divisor | 41030 | 3 | NA |
| Chan 3 Alarm 1 Real | 41031 | 3 | NA |
| Chan 3 Alarm 1 Divisor | 41032 | 3 | NA |
| Chan 3 Alarm 2 Real | 41033 | 3 | NA |
| Chan 3 Alarm 2 Divisor | 41034 | 3 | NA |
| Chan 3 Alarm 3 Real | 41035 | 3 | NA |
| Chan 3 Alarm 3 Divisor | 41036 | 3 | NA |
| | | | |
| Chan 4 Zero Real | 41037 | 3 | NA |
| Chan 4 Zero Divisor | 41038 | 3 | NA |
| Chan 4 Span Real | 41039 | 3 | NA |
| Chan 4 Span Divisor | 41040 | 3 | NA |
| Chan 4 Fault Alarm Real | 41041 | 3 | NA |
| Chan 4 Fault Alarm Divisor | 41042 | 3 | NA |
| Chan 4 Alarm 1 Real | 41043 | 3 | NA |
| Chan 4 Alarm 1 Divisor | 41044 | 3 | NA |
| Chan 4 Alarm 2 Real | 41045 | 3 | NA |
| Chan 4 Alarm 2 Divisor | 41046 | 3 | NA |
| Chan 4 Alarm 3 Real | 41047 | 3 | NA |
| Chan 4 Alarm 3 Divisor | 41048 | 3 | NA |

Memory ASCII Strings:

| | | | |
|------------------|-------------|---|----|
| User Info Chan 1 | 40401-40405 | 3 | NA |
| User Info Chan 2 | 40406-40410 | 3 | NA |
| User Info Chan 3 | 40411-40415 | 3 | NA |
| User Info Chan 4 | 40416-40420 | 3 | NA |

10 ASCII characters (2 per register) assigned to the unit identifier read as bytes.

| | | | |
|---------------|-------------|---|----|
| EUNITS Chan 1 | 40421-40425 | 3 | NA |
| EUNITS Chan 2 | 40426-40430 | 3 | NA |
| EUNITS Chan 3 | 40431-40435 | 3 | NA |
| EUNITS Chan 4 | 40436-40440 | 3 | NA |

10 ASCII characters (2 per register) assigned to the engineering units read as bytes.

| | | | |
|----------------------|-------------|---|----|
| Chan 1 ASCII Reading | 40441-40443 | 3 | NA |
| Chan 2 ASCII Reading | 40444-40446 | 3 | NA |
| Chan 3 ASCII Reading | 40447-40449 | 3 | NA |
| Chan 4 ASCII Reading | 40450-40452 | 3 | NA |

6 ASCII characters (2 per register) reflecting the display readout.

Firmware Version:

| | | | |
|---------|-------------|---|----|
| Version | 40453-40455 | 3 | NA |
|---------|-------------|---|----|

5 ASCII characters (2 per register) reflecting the firmware version.

4.4 Optional External 24VDC 50 Watt Power Supplies

Some applications may require 24VDC power in excess of the 12 watts supplied by the GDA-400. NEC Class 2 FIFTY WATT external supplies are available for Division 1 and Division 2 potentially hazardous area installations and both also include a NEMA 4X weather rating.

5 Wall Mount Enclosure

The GDA-400 wall mount NEMA 4X enclosure is shown in Figure 5.0. Non-metallic enclosures are not grounded by metal conduit. For internal ground points to be grounded to earth, the TB5 – GND terminal must have a proper earth ground connection (see Figure 4.1).



CAUTION: *NONMETALLIC ENCLOSURE DOES NOT PROVIDE GROUNDING BETWEEN CONDUIT CONNECTIONS. USE GROUNDING TYPE BUSHINGS AND JUMPER WIRES. ALL FIELD WIRING MUST HAVE INSULATION SUITABLE FOR AT LEAST 250V.*

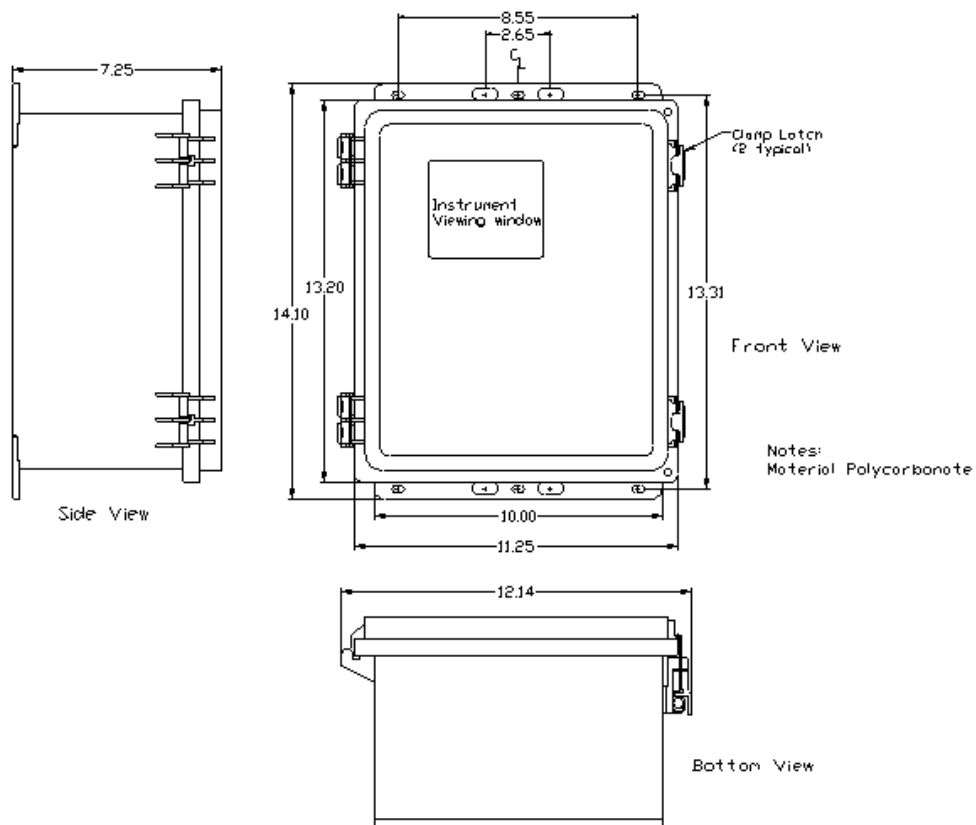

Figure 5.0 – Wall Mount Enclosure

6 Adding the Wireless Radio Kit Option

6.1 Introduction

The GDA-400 *slave* serial port may be connected to a FHSS (Frequency Hopping Spread Spectrum) wireless radio modem shown in Figure 6.1. There are two different frequency options offered:

- 900 MHz (5700-0032)
- 2.4 GHz (5700-0033).

The radio kit options allow two separate modes of wireless operation. These are:

- “Wireless Receiver” (section 6.2) accepting data from GDX-350 RF sensor transmitters
- “Wireless Modbus Slave” (section 6.3) providing data to a modbus *master* (*master* side of network requires additional radio).

Each transceiver on a wireless network must have its **RADIO SETUP** menus configured to share the same hopping channel (0-32) and System ID (0-255) to communicate. All Bacharach wireless transceivers utilize a Server-Client network where Clients synchronize their hopping to the Server. The Server transmits a beacon at the beginning of every hop (50 times per second). Client transceivers listen for this beacon and upon hearing it will indicate **InRange** with the LED on the radio modem board and synchronize their hopping with the Server. Each network should consist of only one Server. There should never be two servers on the same RF Channel number in the same coverage area as the interference between the two servers will severely hinder RF communications. The Server must be in a powered location (as opposed to a battery powered GDX-350 RF utilizing a “sleep” mode) and Servers typically should be centrally located since all Clients must receive the beacon in order to communicate.

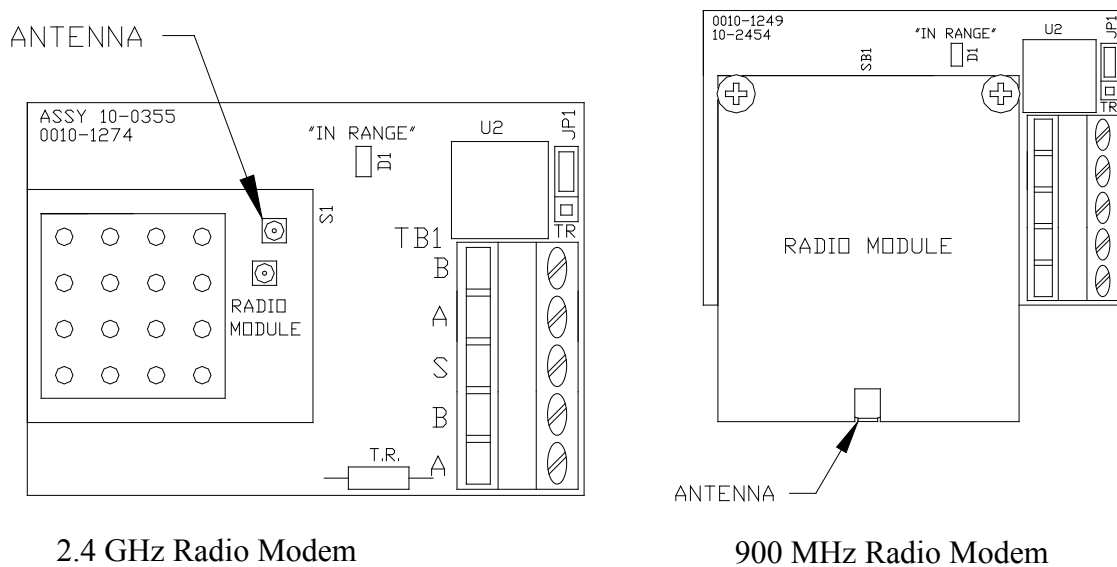

Figure 6.1

6.2 RADIO SETUP MENU

Radio modules must be connected to the GDA-400's radio option board for **RADIO SETUP**. Pressing the EDIT key with the arrow pointing to the **Communications** menu brings the **COMM SETUP** menu to the screen. With the arrow pointing at **Configure Radio** press enter again to enter the **RADIO SETUP** menu (Figure 6.2).

- **Hop Channel** may be set from 1-32 using the GDA-400 keypad and assigns the pseudo-random radio frequency hopping pattern. A transceiver will not go **InRange** of or communicate with a transceiver operating on a different Hop Channel.
- **System ID** may be set from 1-255 using the GDA-400 keypad and is similar to a password character or network number and makes network eavesdropping more difficult. A transceiver will not go **InRange** of or communicate with a transceiver operating on a different System ID.
- **Mode** may be set for **CLIENT** or **SERVER**. For a single GDA-400 communicating to up to four battery powered GDX-350 RF transceivers, Mode must = Server. To prolong battery life, GDX-350 RF's sleep most of the time and therefore may not be Servers. If an application calls for multiple GDA-400 locations, only one may be set for Server and all others must be Clients. This single Server transmits a beacon which all of the network's Clients synchronize to. **ONLY ONE SERVER PER NETWORK.**

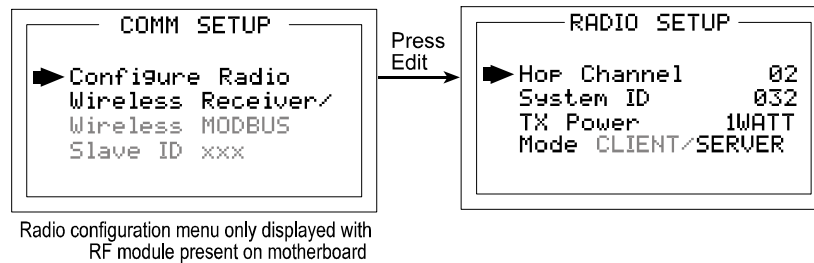

Figure 6.2

6.3 WIRELESS RECEIVER MODE

Wireless Receiver mode is exclusively for wireless communication to our GDX-350 RF wireless sensor transmitters. In Receiver mode the radio connects to the GDA-400's Mother board and receives input data from up to four GDX-350 RF sensor transmitters. Wired and wireless inputs may be mixed between the GDA-400's four channels so it is possible to also accept wired signals from analog input option PCBs described in section 4.2 Input / Output Optional PCBs.

Use the **WIRELESS** setting shown at right of Figure 6.3 ONLY FOR COMMUNICATION TO GDX-350 WIRELESS TRANSCEIVERS.

GDX-350 RF's transmit 200 counts for 0% and 1000 counts for 100% full scale readings so **Input Min/Max** menu values should be 200 and 1000 (factory default). The **Rmt Xmitter ID** menu entry must match the **Remote Id** address setting in the GDX-350 RF providing data to this GDA-400 channel. Voltage level of the 3.6 volt lithium battery in this GDX-350 RF is also displayed on the **ANALOG SETUP** screen, below the Rmt Xmitter Id.

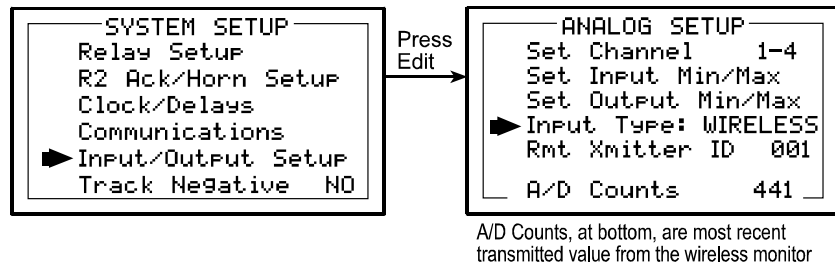

Figure 6.3

6.3.1 RADIO STATUS ALARMS - WIRELESS RECEIVER MODE

When an GDA-400 channel’s **Input Type** is set for **WIRELESS**, in addition to processing the GDX-350 RF’s 10-bit “counts” value, it also receives status bits indicating **Communications Error, Low Battery** and **C**.

- **Communications Error** – Each channel’s 30-minute trend screens (Figure 6.4) are very useful for diagnosing wireless problems since it indicates amount of time since the most recent transmission was received. The down arrow on top of the trend screen resets to far right each time a transmission is received by that channel. When not in alarm, GDX-350 RFs transmit each 5-minutes so the arrow should never progress past the 5-minute interval. The GDA-400 activates the channel’s **FAULT** alarm and indicates **ComErr** if no transmission has been received in 18 consecutive minutes.
- **Low Battery** status indicates the GDX-350 RF’s integral 3.6V lithium D cell has dropped to below 3.3V and should be replaced very soon. **LoBatt** is indicated on the GDA-400’s LCD readout and the Alarm 3 LED flashes. Relays are not energized by low battery conditions. The actual battery voltage of each GDX-350 RF may be seen in the **ANALOG SETUP** screen described above in section 6.3.
- **Calibrations** performed at the ST-48/RF force a transmission of the Calibration bit which is indicated on the GDA-400’s LCD readout by “**Rmt Cal**”. Alarms are inhibited until the Calibration bit is cleared.

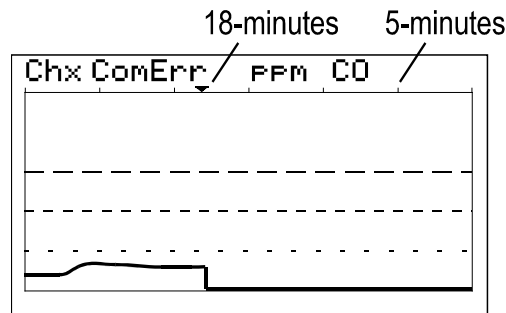

Figure 6.4

6.4 WIRELESS MODBUS SLAVE MODE

Wireless MODBUS allows one or many GDA-400s to function as wireless modbus *slaves* by selecting **wireless MODBUS** in the **COMM SETUP** menu (Figure 6.3). These wireless networks require a modbus *master* such as a DCS, HMI, or other Bacharach controller; also equipped with a radio modem. One transceiver must be

designated as Server and all others as Clients. No special configuration is required by the *master* or *slave* since this is a standard modbus network. However, radios must have the same **Hop Channel** and **System ID** settings to communicate.

The entire GDA-400 modbus database, including registers and supported Function Codes, is documented in section 4.3.

6.5 ANTENNA SELECTION

6.5.1 DIPOLE AND COLLINEAR ANTENNAS

These antennas are connected to the Radio via a length of coax cable. If the cable is larger than 6mm diameter (1/4 inch), do not connect the cable directly to the radio connection on the GDA-400 enclosure. Thick cables have large bending radii and sideways force on the connector can cause a poor connection. Use a short flexible pigtail between the thick cable and the radio connection.

The polarity of these antennas is the same as the main axis, and they are normally installed vertically. They can be mounted horizontally (horizontal polarity), however the antenna at the other end of the wireless link would need to be mounted perfectly parallel for optimum performance. This is very difficult to achieve over distance. If the antenna is mounted vertically, it is only necessary to mount the other antennas vertically for optimum “coupling” – this is easy to achieve.

Dipole and collinear antennas provide best performance when installed with at least 1 to 2 “wavelengths” clearance of walls or steelwork. The wavelength is based on the frequency:

Wavelength in meters = 300 / frequency in MHz

Wavelength in feet = 1000 / frequency in MHz

Therefore, 900 MHz antennas require at least 2/3 meter (2 feet) and 2.4GHz 15 cm (6 inches). Antennas may be mounted with less clearance but radiation will be reduced. It is important for the antenna mounting bracket to be well connected to “earth” or “ground” for good lightning surge protection.

6.5.2 YAGI ANTENNAS

Yagi antennas are directional along the central beam of the antenna. The folded element is towards the back and the antenna should be “pointed” in the direction of the transmission. Yagis should also be mounted with at least 1 to 2 wavelengths of clearance from other objects. The polarity of the antenna is the same as the direction of the orthogonal elements. For example, if the elements are vertical the Yagi transmits with vertical polarity.

In networks spread over wide areas, it is common for a central unit to have an omni-directional antenna and the remote units to have Yagi antennas. In this case, as the omni-directional antenna will be mounted with vertical polarity, then the Yagi’s must also have vertical polarity. Care needs to be taken to ensure the Yagi is aligned correctly to achieve optimum performance.

Two Yagis can be used for a point-to-point link. In this case they can be mounted with the elements horizontally to give horizontal polarity. There is a large degree of RF isolation between horizontal and vertical polarity (approx -30dB) so this installation method is a good idea if there is a large amount of interference from another system close by transmitting vertical polarity.

An important mounting tip – if a Yagi has drainage holes in the dipole element, do not mount the antenna with the drainage.

6.5.3 MOUNTING NEAR OTHER ANTENNAS

Avoid mounting your network's antenna near any other antenna even when the other antenna is transmitting on a different radio band. High RF energy of the transmission from a close antenna can “deafen” a receiver. This is a common cause of problems with wireless systems.

Because antennas are designed to transmit parallel to the ground rather than up or down, vertical separation between antennas is a lot more effective than horizontal separation. If mounting near another antenna cannot be avoided, mounting it beneath or above the other antenna is better than mounting beside it. Using different polarity to the other antenna (if possible) will also help to isolate the RF coupling.

6.5.4 COAX CABLES

If a coax cable connects to the antenna via connectors, it is very important to weatherproof the connection using sealing tape. Moisture ingress into a coax cable connection is the most common cause of problems with antenna installations. A three layer sealing process is recommended – an initial layer of electrical PVC tape, followed by a second layer of self-vulcanizing weatherproofing tape, with a final layer of electrical PVC tape.

Allowing a drip “U loop” of cable before the connection is also a good idea. The loop allows water to drip off the bottom of the U instead of into the connection, reduces installation strain and provides spare cable length in case later the original connectors need to be removed, the cable cut back and new connectors fitted.

Avoid installing coax cables together in long parallel paths. Leakage from one cable to another has a similar effect as mounting an antenna near another antenna.

6.6 SURGE PROTECTION AND GROUNDING

Voltage surges can enter the GDA-400 via the antenna connection, power supply connection, connections to other equipment and even the “earth” or “ground” connection. Surges are electrical energy following a path to earth and the best protection is achieved by “draining” the surge energy to earth via an alternate path. Wireless devices need to have a solid connection to earth via a ground stake or ground grid if the soil has poor conductivity. Solid connection means a large capacity conductor (not a small wire) with no coils or sharp bends. All other devices connected to the GDA-400 need to be grounded to the same ground point. There can be significant resistance between different ground points leading to very large voltage differences during lightning activity. Many wireless units are damaged by earth potential surges due to incorrect grounding.

It is very difficult to protect against direct lightning strikes but the probability of a direct strike at any one location is very small. Unfortunately, power line surges and electromagnetic energy in the air can induce high voltage surges from lightning activity several miles away.

6.6.1 ANTENNA GROUNDING

Electromagnetic energy in the air will be drained to ground via any and every earth path. An earth path exists between the antenna and the GDA-400 and to protect against damage this earth path current must be kept as small as possible. This is achieved by providing better alternate earth paths. It is important to ground the antenna to the same ground point as the GDA-400. Antennas are normally mounted to a metal bracket which should be grounded to the GDA-400 earth connection. Surge energy induced into the antenna will be drained first by the mount's ground connection, second by the outside shield of the coax cable to the ground connection on the radio and third by the internal conductor of the coax cable via the radio electronics. This third earth path causes damage unless the other two paths provide a better earth connection allowing surge energy to bypass the electronics.

When an antenna is located outside of a building and outside of an industrial plant environment, external coax surge diverters are recommended to further minimize the effect of surge current in the inner conductor of the coax cable.

Coax surge diverters have gas-discharge element which breaks down in the presence of high surge voltage and diverts any current directly to a ground connection. A surge diverter is not normally required when the antenna is within a plant or factory environment, as the plant steelwork provides multiple parallel ground paths and good earthing will provide adequate protection without a surge diverter.

6.6.2 CONNECTIONS TO OTHER EQUIPMENT

Surges can enter the wireless unit from connected devices, via I/O, serial or Ethernet connections. Other data devices connected to the wireless unit should be well grounded to the same ground point as the wireless unit.

Special care needs to be taken where the connected data device is remote from the wireless unit requiring a long data cable. As the data device and the wireless unit cannot be connected to the same ground point, different earth potentials can exist during surge conditions.

There is also the possibility of surge voltages being induced on long lengths of wire from nearby power cables. Surge diverters can be fitted to the data cable to protect against surges entering the wireless unit.

The same principle applies to I/O devices that are not close to the wireless unit—the risk of surge increases.

7 Service Centers

United States

8621 Highway 6

Hitchcock, TX 77563

Ph: 724-334-5051

Fax: 724-334-5723

Email: help@MyBacharach.com



621 Hunt Valley Circle, New Kensington, PA 15068-7074
Toll Free: 800-736-4666 • Tel: +1-724-334-5000 • FAX: +1-724-334-5001
Website: www.MyBacharach.com • E-mail: help@MyBacharach.com

