

Thank You

Thanks for purchasing a PT-500 series pressure transmitter from us! We appreciate your business and your trust. Please take a moment to familiarize yourself with the product and this manual before installation. If you have any questions, at any time, don't hesitate to call us at 888-525-7300.

NOTE: Scan the appropriate QR code to the below to see the full user manual on your tablet or smartphone. Or visit www.apgsensors.com/support to find it on our website.

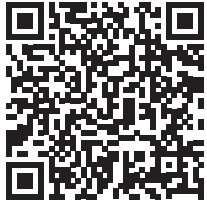

PT-500 Analog Output Manual

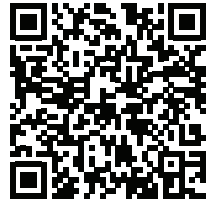

PT-500 Modbus Manual

Table of Contents

1. Description	5. Dimensions	9. General Care
2. How To Read Your Label	6. Wiring Information	10. Repair Information
3. Warranty	7. Zero Adjust	11. Removal Instructions
4. Mounting Instructions	8. Vent Tube Drying	12. Hazardous Location Wiring

1 Description

PT-500 submersible pressure transmitters offer reliability in harsh industrial conditions and hazardous locations. The 4-20 mA version is certified intrinsically safe for hazardous areas in the US and Canada by CSA for Class I, Division 2, Groups C and D, Class I, Zone 2, Group IIB, and Class I, Division 1, Groups C and D, Class I, Zone 0, Group IIB environments. The small size, integrated electronics, wide operating temperature range, and durability make the PT-500 the perfect instrument for static and dynamic pressure measurement.

2 How To Read Your Label

Each label comes with a full model number, a part number, and a serial number. The model number for the PT-500 will look something like this:

SAMPLE: PT-500-400-FTH2O-L1-E0-P37-500-N0

The model number correlates with all the configurable options and tells you exactly what you have. Compare the model number to the options on the datasheet to identify your exact configuration. You can also call us with the model, part, or the serial number and we can help you.

The label also includes the pinout, as does this installation guide.

You'll also find all hazardous certification information on the label.

3 Warranty

APG warrants its products to be free from defects of material and workmanship and will, without charge, replace or repair any equipment found defective upon inspection at its factory, provided the equipment has been returned, transportation prepaid, within 24 months from date of shipment from factory.

THE FOREGOING WARRANTY IS IN LIEU OF AND EXCLUDES ALL OTHER WARRANTIES NOT EXPRESSLY SET FORTH HEREIN, WHETHER EXPRESSED OR IMPLIED BY OPERATION OF LAW OR OTHERWISE INCLUDING BUT NOT LIMITED TO ANY IMPLIED WARRANTIES OF MERCHANTABILITY OR FITNESS FOR A PARTICULAR PURPOSE.

No representation or warranty, express or implied, made by any sales representative, distributor, or other agent or representative of APG which is not specifically set forth herein shall be binding upon APG. APG shall not be liable for any incidental or consequential damages, losses or expenses directly or indirectly arising from the sale, handling, improper application or use of the goods or from any other cause relating thereto and APG's liability hereunder, in any case, is expressly limited to the repair or replacement (at APG's option) of goods.

Warranty is specifically at the factory. Any on site service will be provided at the sole expense of the Purchaser at standard field service rates.

All associated equipment must be protected by properly rated electronic/electrical protection devices. APG shall not be liable for any damage due to improper engineering or installation by the Purchaser or third parties. Proper installation, operation and maintenance of the product becomes the responsibility of the user upon receipt of the product.

Returns and allowances must be authorized by APG in advance. APG will assign a Return Material Authorization (RMA) number which must appear on all related papers and the outside of the shipping carton. All returns are subject to the final review by APG. Returns are subject to restocking charges as determined by APG's "Credit Return Policy".

4 Mounting Instructions

Your PT-500 can be mounted in three ways: via NPT process connection, free-hanging suspension, or conduit mounted. Mounting your pressure transducer is easy if you follow a few simple steps:

- Never over-tighten the sensor. This can compress the diaphragm, changing how it reacts to pressure. In all cases, tighten the sensor as little as possible to create an adequate seal.
- Always use thread tape or sealant compound on tapered threads. Wrap thread tape in the opposite direction of the threads so it does not unravel as you screw the sensor into place. Unraveling can cause uneven distribution and seal failure.
- Always start screwing in your sensor by hand to avoid cross-threading. Thread failure can be a problem if you damage threads by over-tightening them or by crossing threads.
- For suspension mounting the PT-500, drill a 3/16" hole into the 1/2" NPTF to 1/2" NPTF hex coupler (P/N 511414) and secure it to the 1/2" NPTM coupler fitting of the PT-500. Attach a .060" diameter 316L SS cable of desired length to the hex coupler and secure the steel cable according to your application requirements.

IMPORTANT: Refer to section 12 for Hazardous Location Wiring.

PT-500 Series Pressure Transmitters

Installation Guide

For Analog Output and Modbus Series



Automation Products Group, Inc.
1025 W 1700 N Logan, UT 84321
www.apgsensors.com | phone: 888-525-7300 | email: sales@apgsensors.com

Part # 122950-0004
Doc #9004122 Rev A2

5 Dimensions

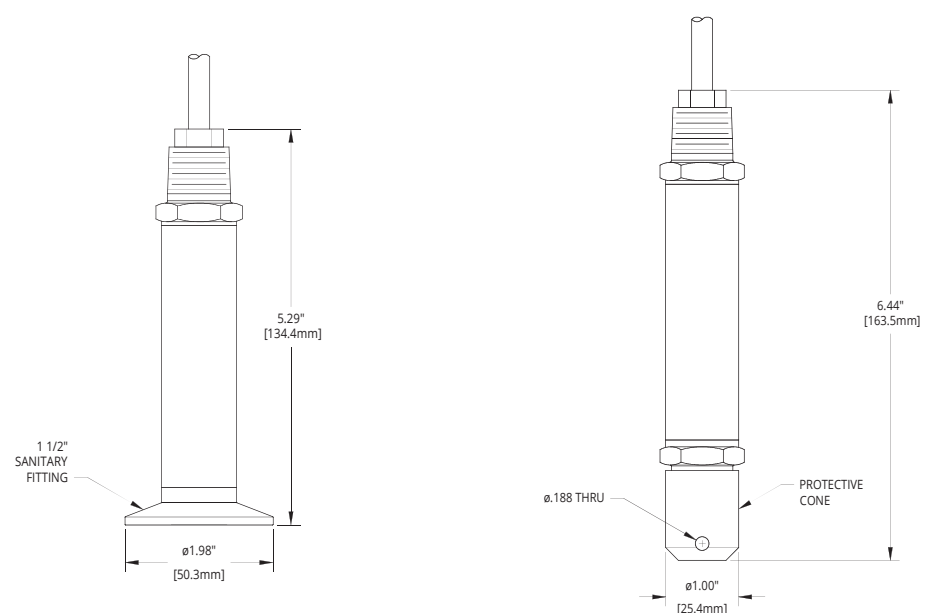
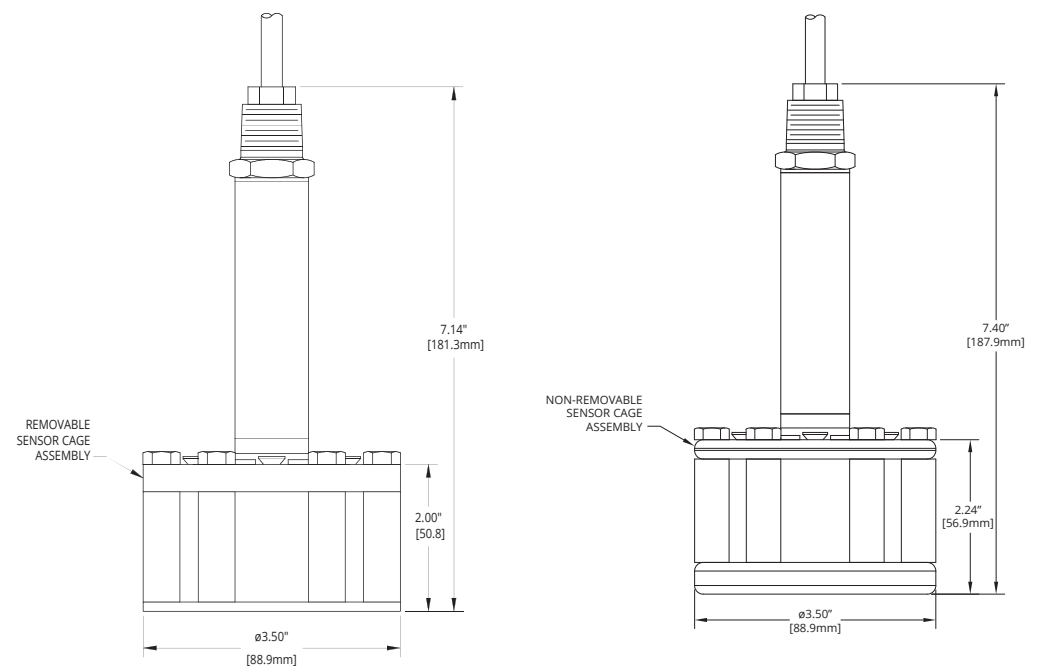

6 Wiring Information

PT-500 Series Pin Out Table

Pigtail		4-20 mA	Voltage	Modbus
Red		+ Power/Signal	+ Power	+ Power
Black		- Power/Signal	- Power	- Power
Green		-	+ Out	B (TX-)
White		-	- Out	A (TX+)
Shield		Case Gnd	Case Gnd	Case Gnd

PT-500 Series Supply Power Table

	4-20 mA	0-5 VDC	0-10 VDC	mV/V	Modbus
Power Supply	9-28 VDC	9-28 VDC	14-28 VDC	10 VDC*	5-28 VDC

* mV/V output calibrated to 10 VDC input.

PT-500 4-20 mA System Wiring

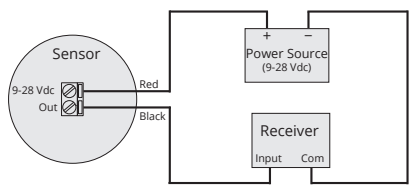

PT-500 Voltage System Wiring

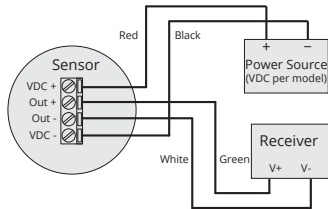

PT-500 Modbus System Wiring

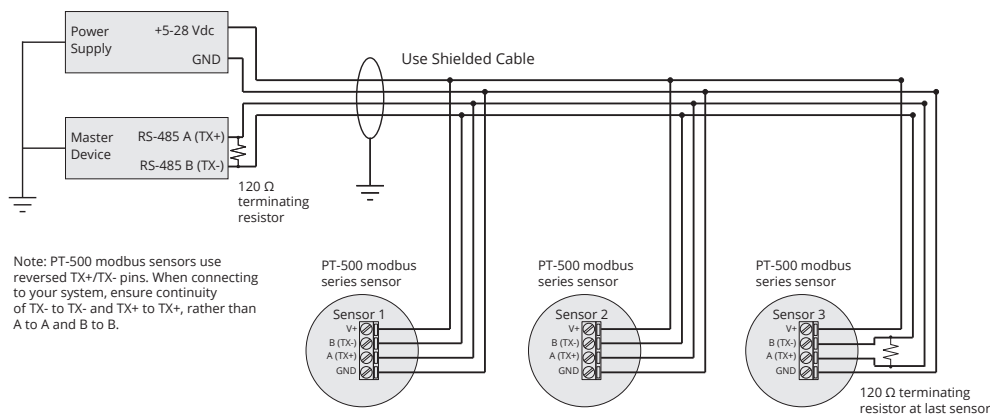

7 Zero Adjust (4-20 mA, 0-5 VDC, and 0-10 VDC series Only)

The zero output (4mA or 0 VDC) can be adjusted by holding a magnet perpendicular to the can, approximately 1-1/2" from the top or bottom of the can.

Holding the magnet close to the top of the can increases the output. Holding the magnet close to the bottom of the can decreases the output.

If the zero output values do not change right away, hold the magnet in place near the top of the can until the values change, for up to two minutes. If there is no change, repeat the procedure near the bottom of the can. If there is still no change, consult the factory.

Unvented PT-500A transmitters do not automatically adjust to changes in barometric pressure. We recommend that PT-500A transmitters be zeroed upon receipt, and after major weather events.

NOTE: Span calibration must be done at the factory for all analog models.

8 Vent Tube Drying

Condensation in the vent tube can damage the electronics in your sensor, resulting in unreliable readings. APG offers two methods of preventing vent tube condensation: a venting cap and a desiccant drying cartridge.

The venting cap is a PVC tube with a hydrophobic patch that allows moisture to pass out of the tube without allowing water in. The cap is sealed by an o-ring, and is easily installed in the field.

The desiccant drying cartridge with vent tube adapter absorbs any moisture in the vent tube to keep vapor from condensing. The installation of the desiccant drying cartridge is quick and easy. Common installation methods are cable tie, Velcro, and cable clamps.

NOTE: Desiccant crystals change from blue to pink as they become saturated. Cartridge must be replaced when all crystals have saturated.

IMPORTANT: Do NOT use desiccant cartridge in the presence of vapors of liquids containing phosphate esters, synthetic lubricant, hydrocarbon solvents, methanol, acetone, lacquer solvents, or other organics.

9 General Care

Your pressure transmitter is very low maintenance and will need little care, as long as it was installed correctly. However, in general, you should:

- For process connected sensors, keep the sensor and the area around it generally clean.
- Avoid applications for which the sensor was not designed, such as extreme temperatures, contact with incompatible corrosive chemicals, or other damaging environments.
- Inspect the threads whenever you remove the sensor from duty or change its location.
- Avoid touching the diaphragm. Contact with the diaphragm, especially with a tool, could permanently shift the output and ruin accuracy.
- Cleaning the diaphragm or the diaphragm bore should be done with extreme care. If using a tool is required, make sure it does not touch the diaphragm.

IMPORTANT: Any contact with the diaphragm can permanently damage the sensor. Use extreme caution.

10 Repair Information

If your pressure transmitter needs repair, contact us via email, phone, or on-line chat on our website. We will issue you an RMA number with instructions.

- Phone: 888-525-7300
- Email: sales@apg sensors.com
- Online chat at www.apg sensors.com

11 Removal Instructions

Removing your PT-500 from service must be done with care. It's easy to create an unsafe situation, or damage your sensor, if you are not careful to follow these guidelines:

- For sensors installed via NPT process connection, make sure the pressure is completely removed from the line or vessel. Follow any and all procedures for safely isolating any media contained inside the line or vessel.
- Remove the sensor with an appropriately sized wrench (per your process connection).
- For suspended sensors, retrieve the sensor from the vessel. Follow any and all procedures for safely isolating any media contained inside the line or vessel.
- Carefully clean the sensor's fitting and diaphragm of any debris (see General Care) and inspect for damage.
- Store your sensor in a dry place, at a temperature between -40° F and 180° F.

DANGER: Removing the pressure transmitter while there is still pressure in the line or vessel could result in injury or death.

12 Hazardous Location Wiring

Intrinsically Safe Wiring (4-20mA Output)

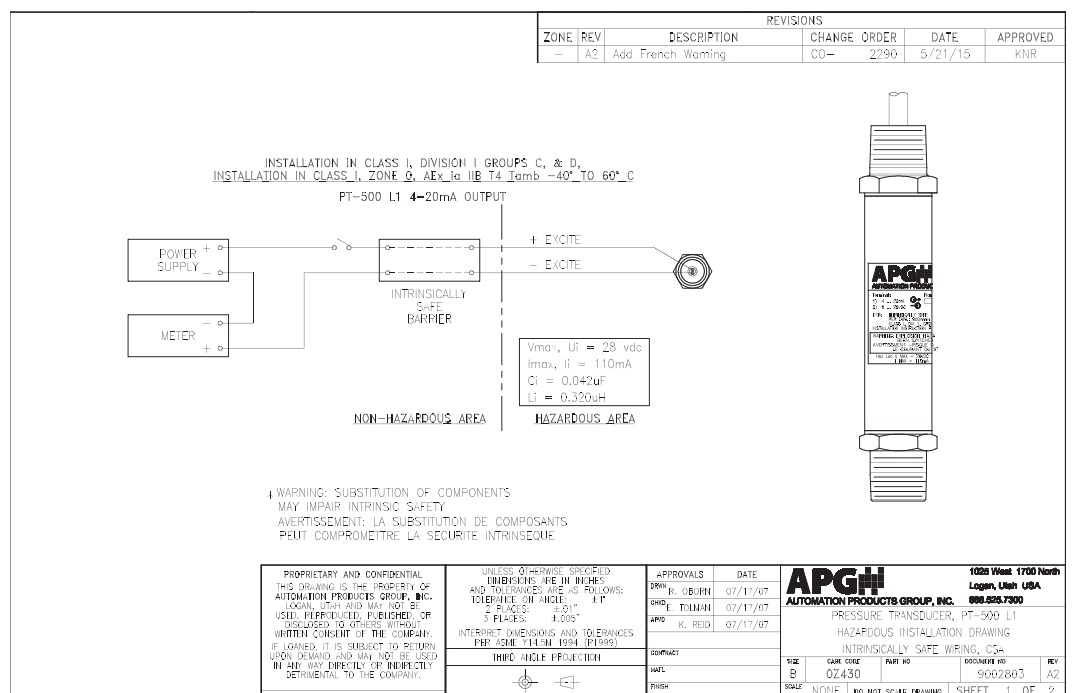

Non-Incendive Wiring (4-20mA Output)

